

---

# Critical Neutron-Rich Sn Isotopes in Rapid Neutron- Capture Process

Melvin Storbäck

under the direction of  
Assoc. Prof. Chong Qi

Annual Swedish Nuclear Physicist's  
meeting and SFAIR Meeting 2022  
October 26, 2022

---

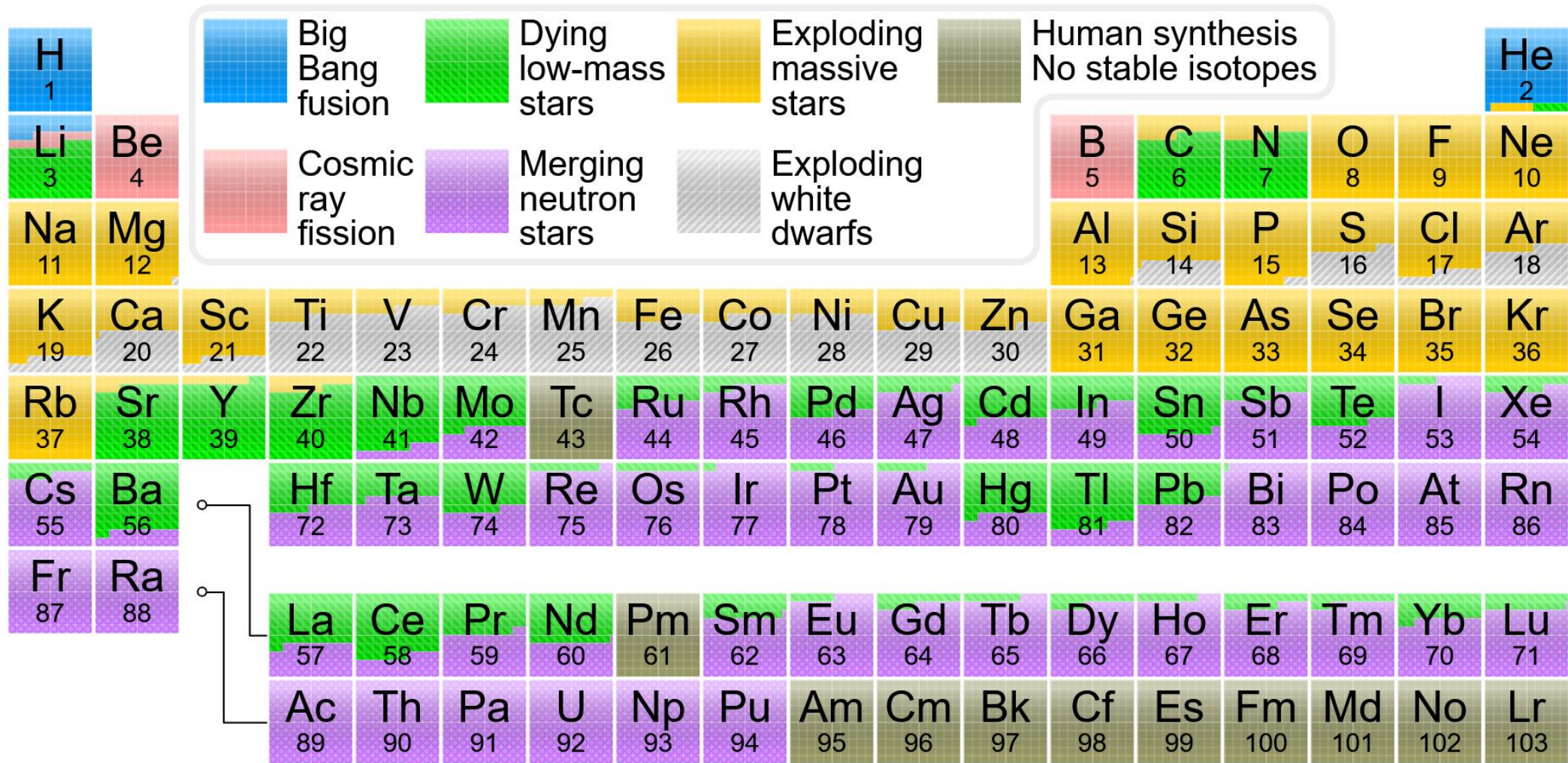

# The r-process

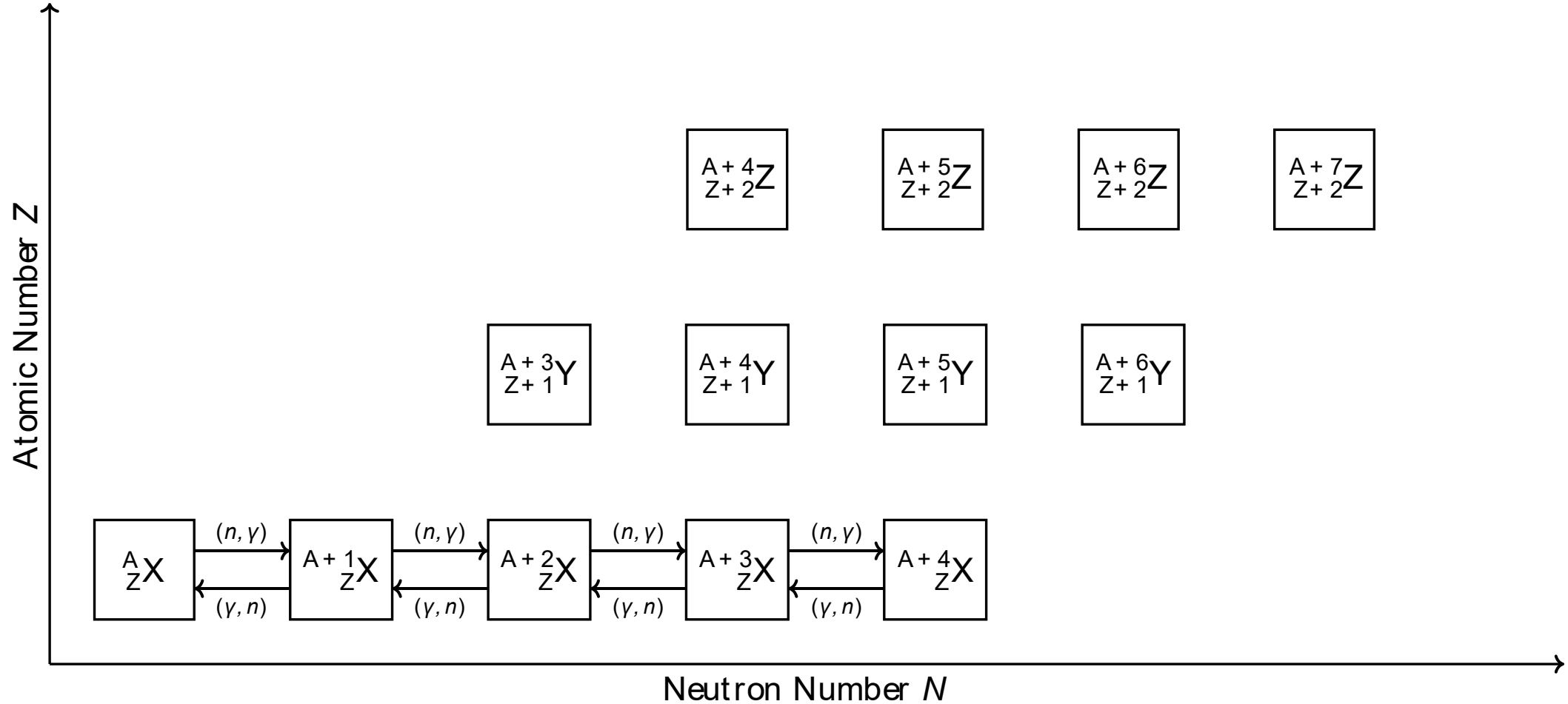

# The r-process

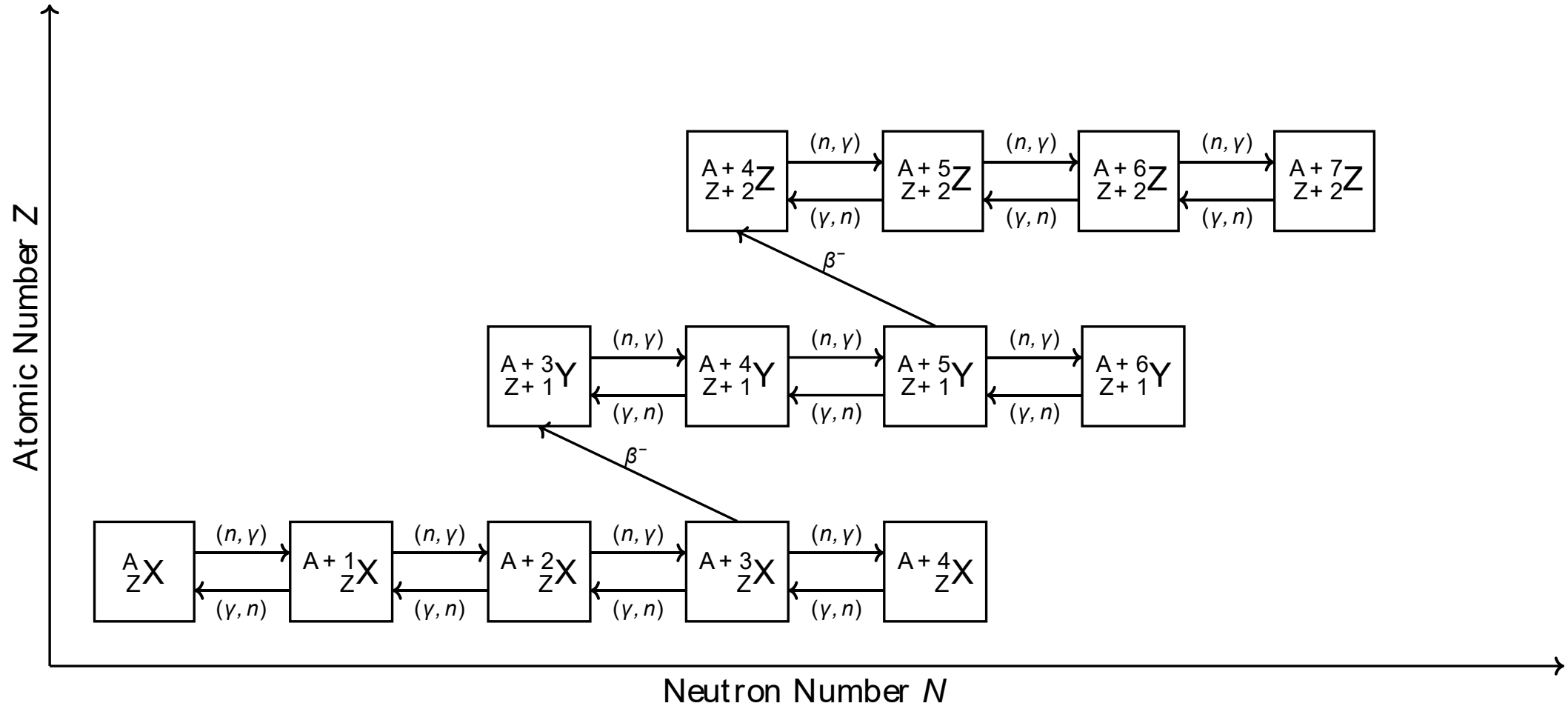

# r-process Simulations

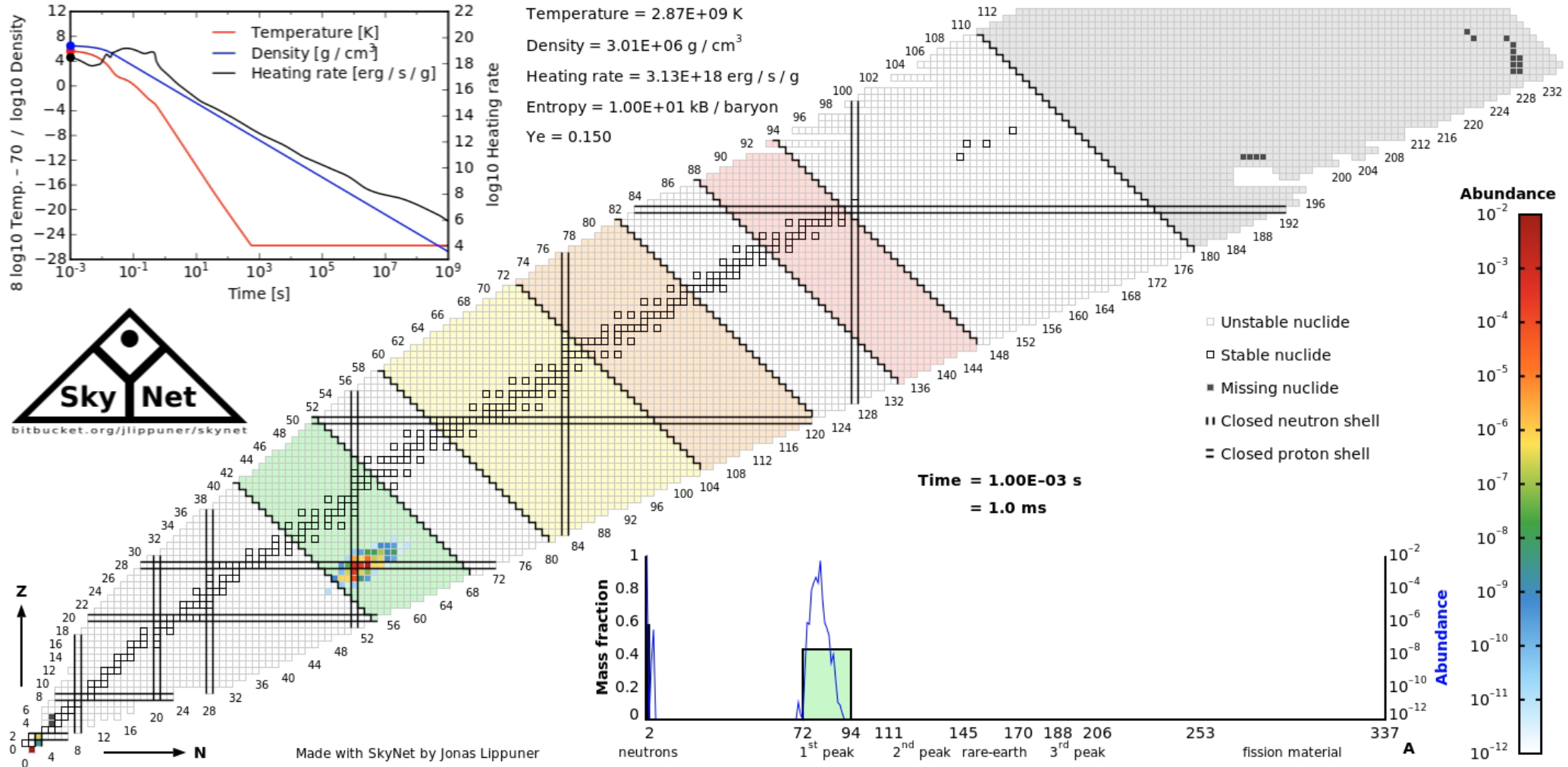

# Mass Models

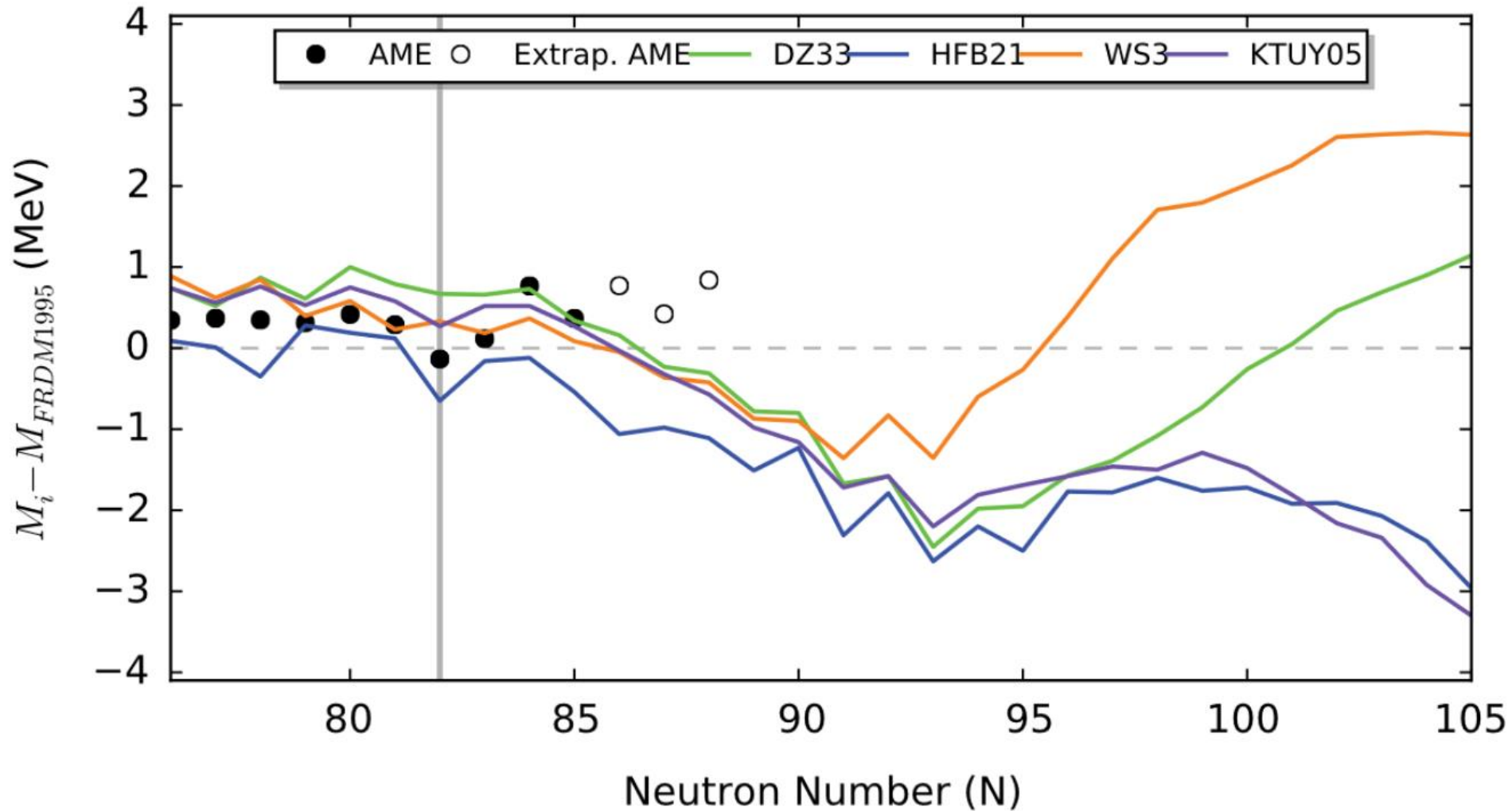

# Impact of Nuclear Masses

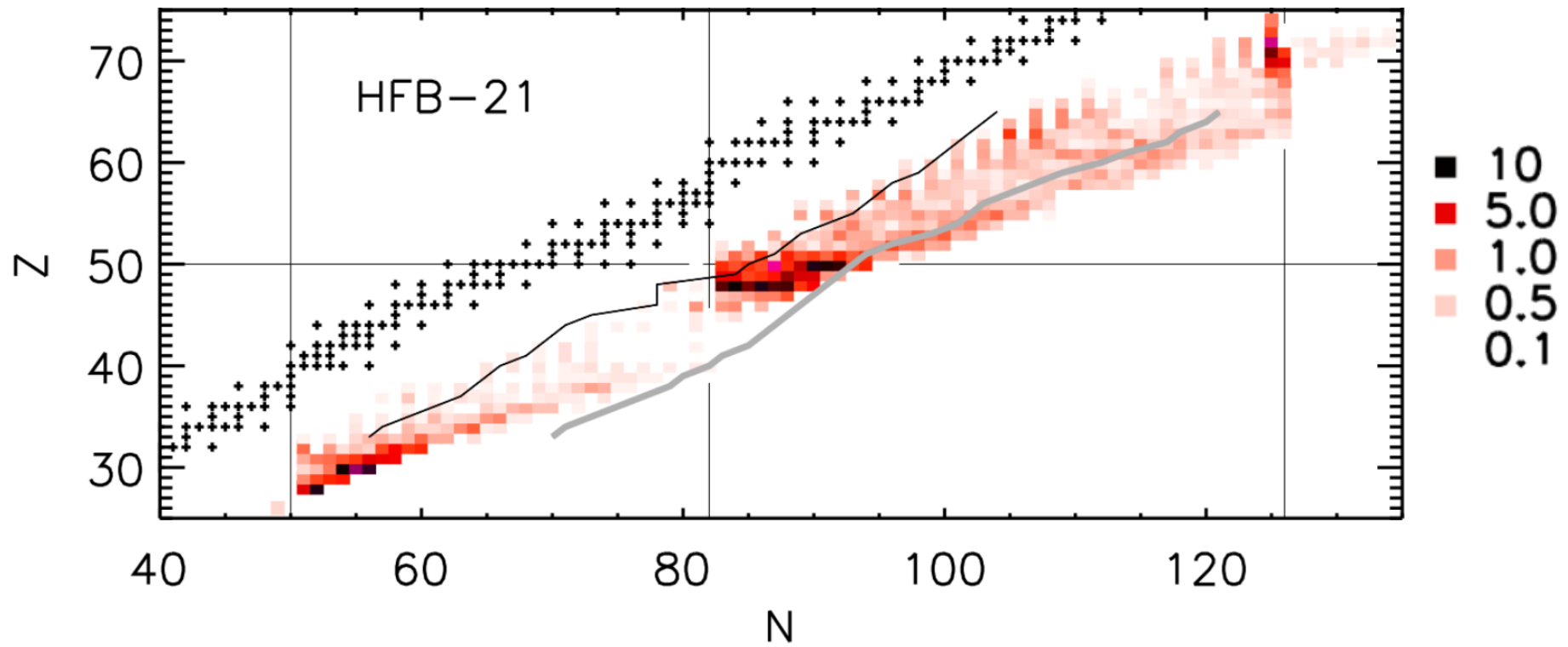

# Method

---

- Simulations in r-Java 2.0
  - F-value: 
$$F = 100 \sum_A |X_{baseline}(A) - X_{\Delta m}(A)|$$
  - Temperature and density variations
    - $2 \cdot 10^9 - 4 \cdot 10^9$  K
    - $1 \cdot 10^7 - 1 \cdot 10^{11}$  g cm<sup>-3</sup>
    - Sn Masses +20 MeV
  - Individual mass variations  
+20 MeV
-



# Results & Discussion

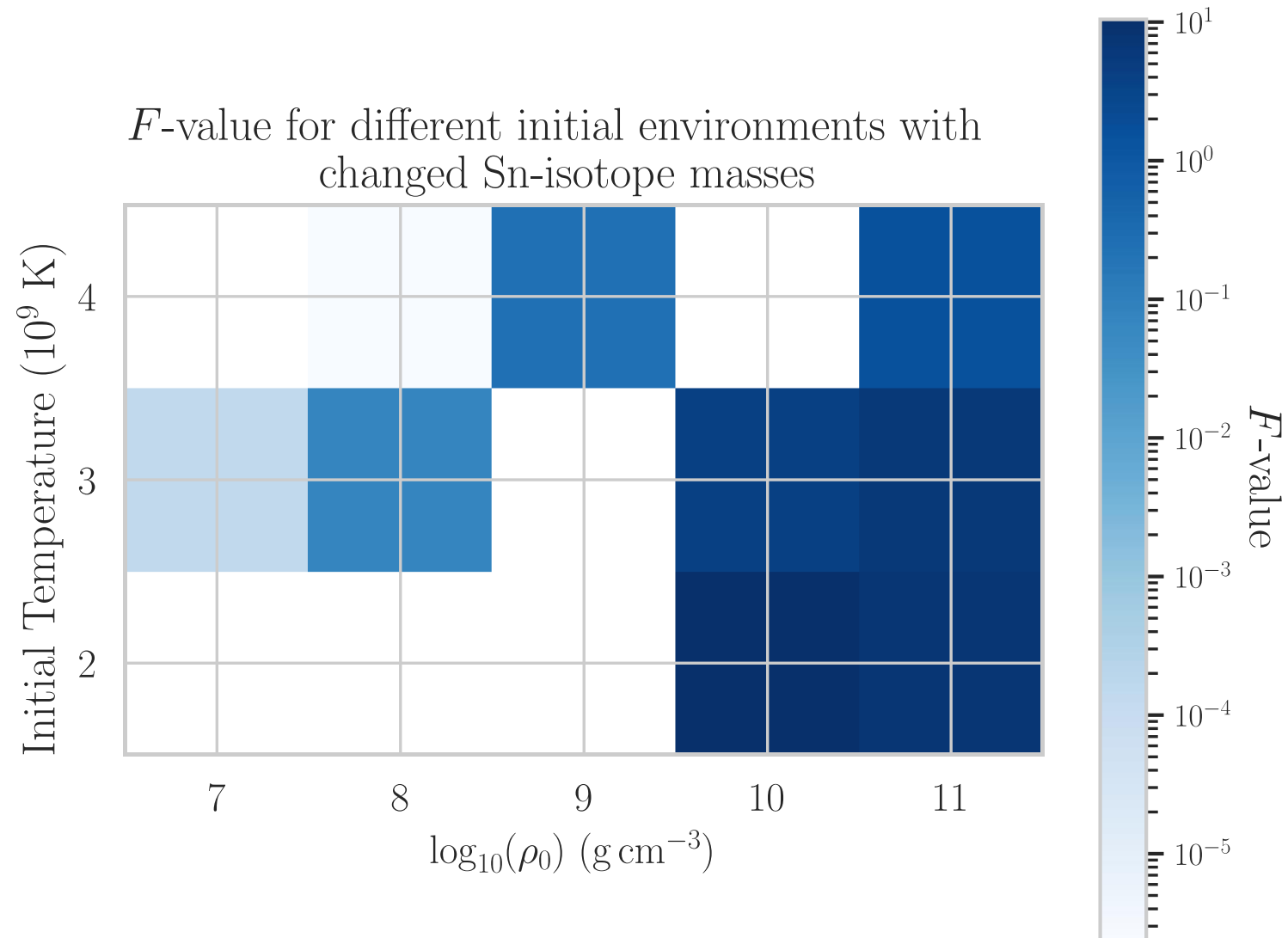

# Results & Discussion

---

$F$ -value for individually increased masses of Sn-isotopes

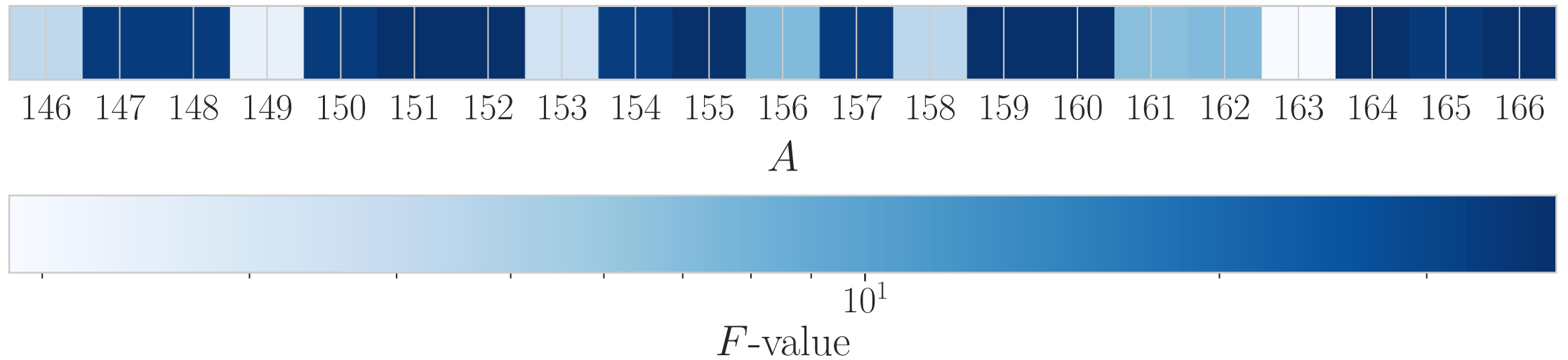

# Current/Future Work

- “Continuous” variation of models
  - More physical representation of uncertainty
  - Reflects gain of measurement

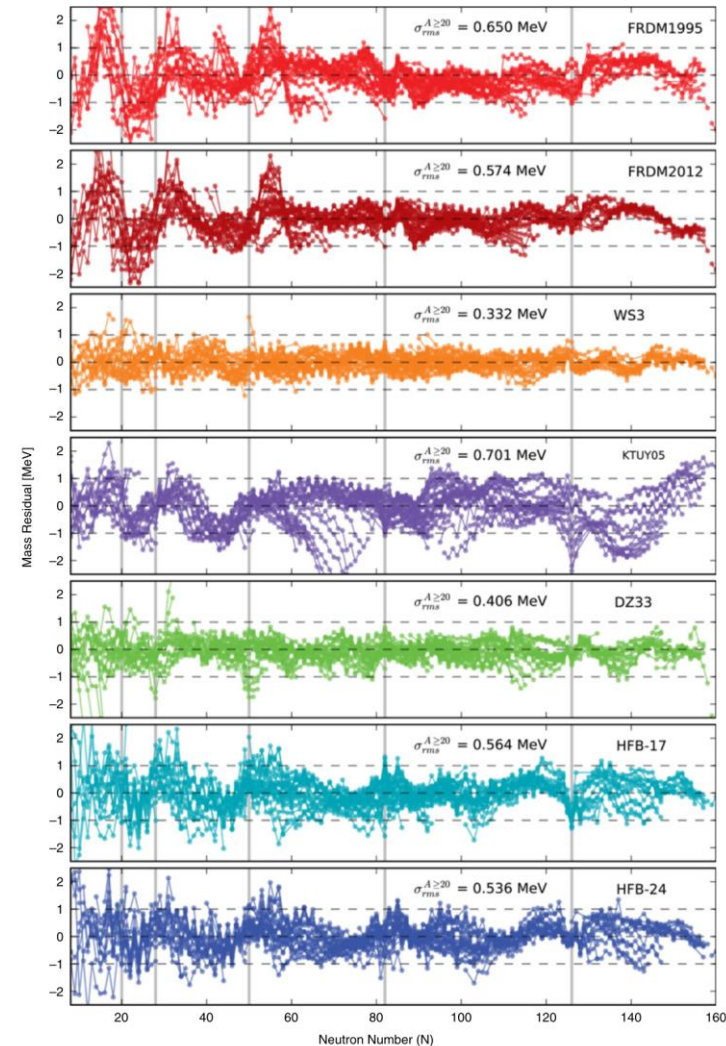

# References

---

- [1] Cmglee, CC BY-SA 3.0 <<https://creativecommons.org/licenses/by-sa/3.0>>, via Wikimedia Commons
  - [2] Mumpower MR, Surman R, McLaughlin G, Aprahamian A. The impact of individual nuclear properties on r-process nucleosynthesis. *Progress in Particle and Nuclear Physics*. 2016;86:86-126.
  - [3] Brett S, Bentley I, Paul N, Surman R, Aprahamian A. Sensitivity of the r-process to nuclear masses. *The European Physical Journal A*. 2012;48(12):1-5.
-