



Accelerating Science

Accélérateur de science



Controlar Vácuo & Criogenia nos aceleradores

Paulo.Gomes@cern.ch

(& Andre.Rocha@cern.ch)

TE / VSC

TE – Technology Department

VSC – Vacuum, Surfaces & Coatings Group

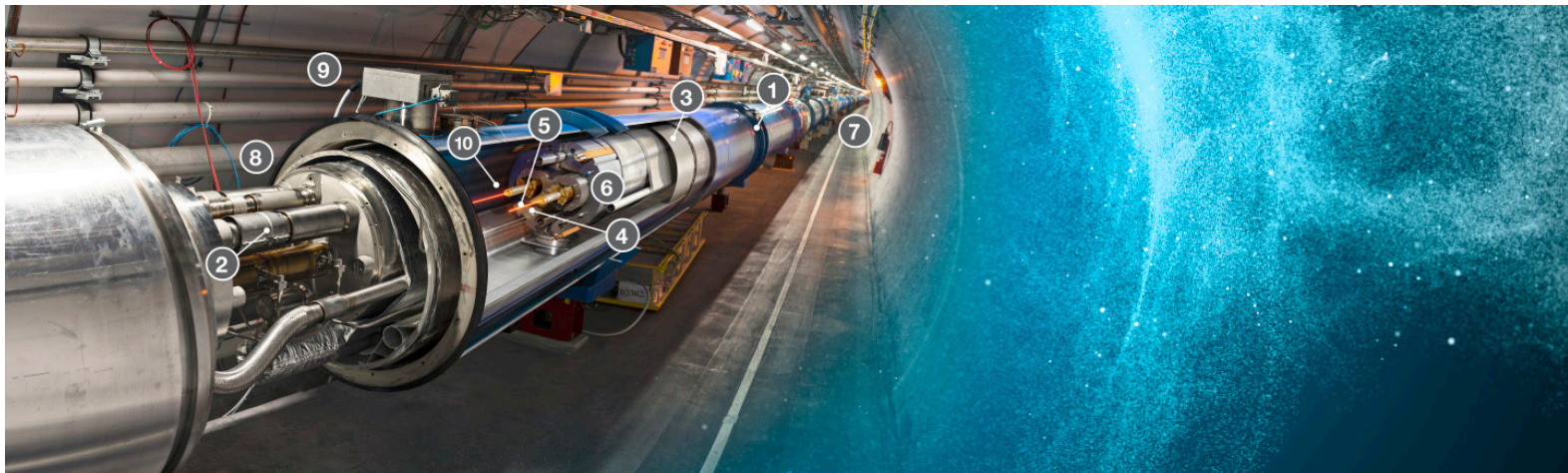

Portuguese Language Teachers Program

5 Sep 2023

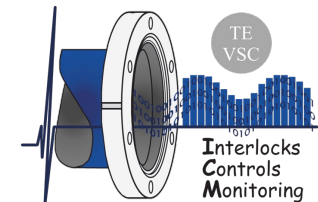

os aceleradores do CERN

criogenia para quê

vácuo para quê

instrumentos e controladores

arquitectura de controlo

o Complexo de Aceleradores (prótons)

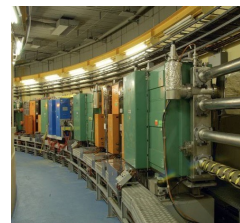
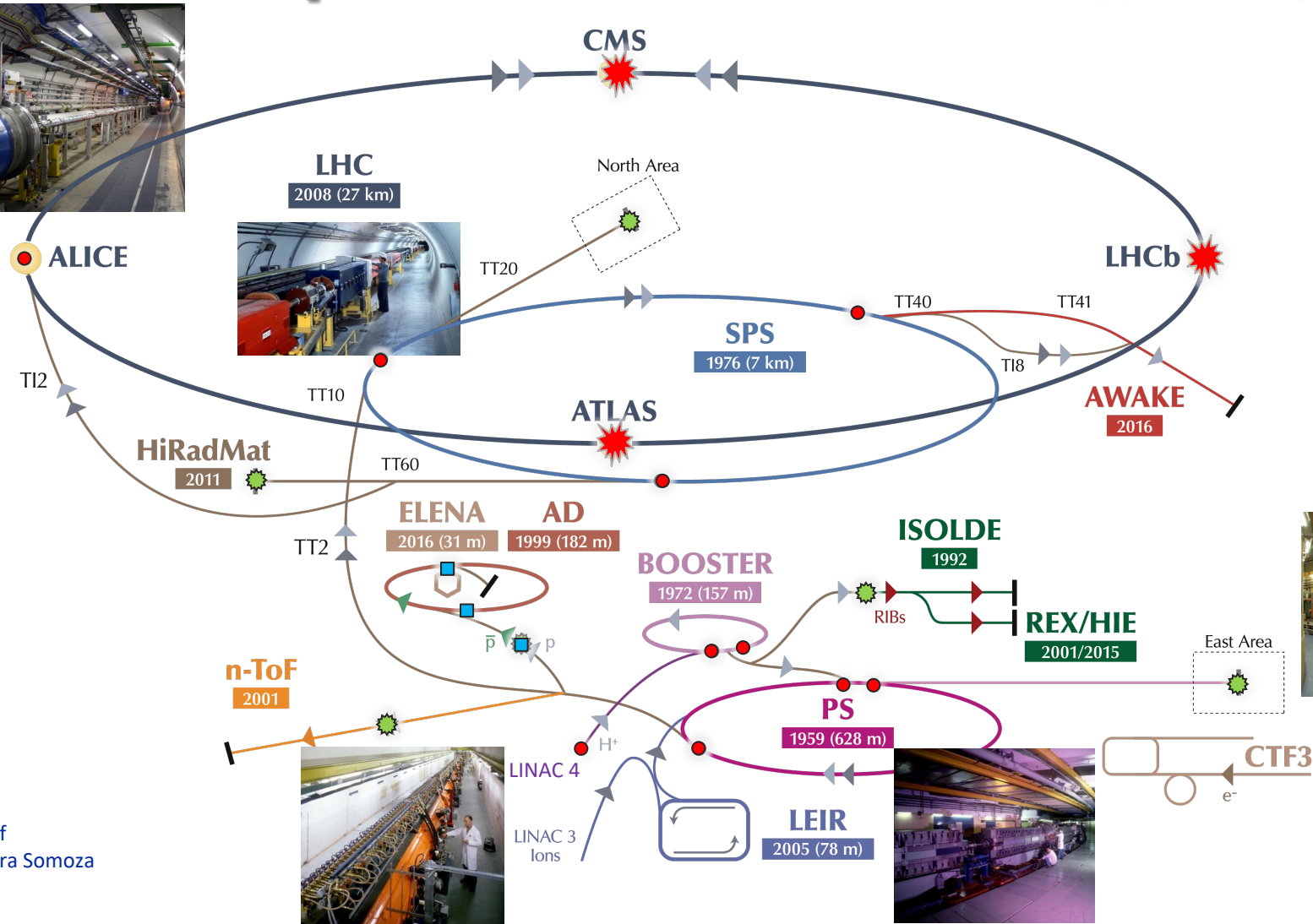
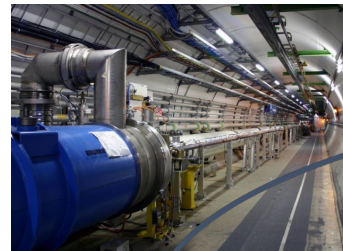

Courtesy of
Jose Ferreira Somoza
(TE-VSC)

- ▶ p (protons)
- ▶ ions
- ▶ RIBs (Radioactive Ion Beams)
- ▶ n (neutrons)
- ▶ \bar{p} (antiprotons)
- ▶ e^- (electrons)
- ▶ \leftrightarrow proton/antiproton conversion
- ▶ \rightarrow proton/RIB conversion

LHC Large Hadron Collider | SPS Super Proton Synchrotron | PS Proton Synchrotron | AD Antiproton Decelerator | CTF3 Clic Test Facility

AWAKE Advanced WAKEfield Experiment | ISOLDE Isotope Separator OnLine | REX/HIE Radioactive EXperiment/High Intensity and Energy ISOLDE

LEIR Low Energy Ion Ring | LINAC LINear ACcelerator | n-ToF Neutrons Time Of Flight | HiRadMat High-Radiation to Materials

<https://home.web.cern.ch/about>



o Complexo de Aceleradores (ões)

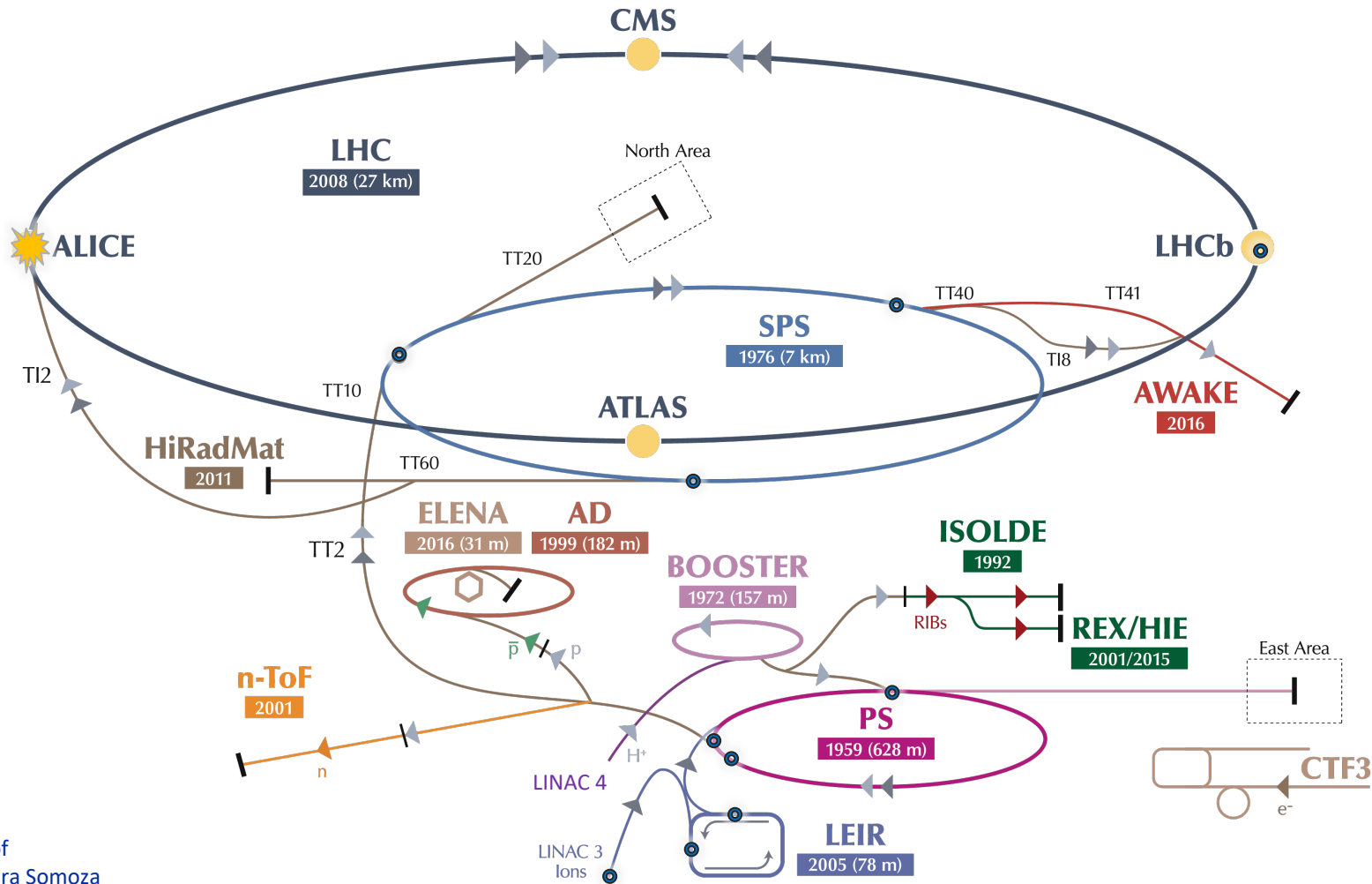

Courtesy of
Jose Ferreira Somoza
(TE-VSC)

▶ p (protons)
▶ ions
▶ RIBs (Radioactive Ion Beams)
▶ n (neutrons)
▶ \bar{p} (antiprotons)
▶ e^- (electrons)
▶ \leftrightarrow proton/antiproton conversion
▶ \leftrightarrow proton/RIB conversion

LHC Large Hadron Collider
SPS Super Proton Synchrotron
PS Proton Synchrotron
AD Antiproton Decelerator
CTF3 Clic Test Facility

AWAKE Advanced WAKEfield Experiment
ISOLDE Isotope Separator OnLine
REX/HIE Radioactive EXperiment/High Intensity and Energy ISOLDE

LEIR Low Energy Ion Ring
LINAC LINear ACcelerator
n-ToF Neutrons Time Of Flight
HiRadMat High-Radiation to Materials

<https://home.web.cern.ch/about>



LHC em números

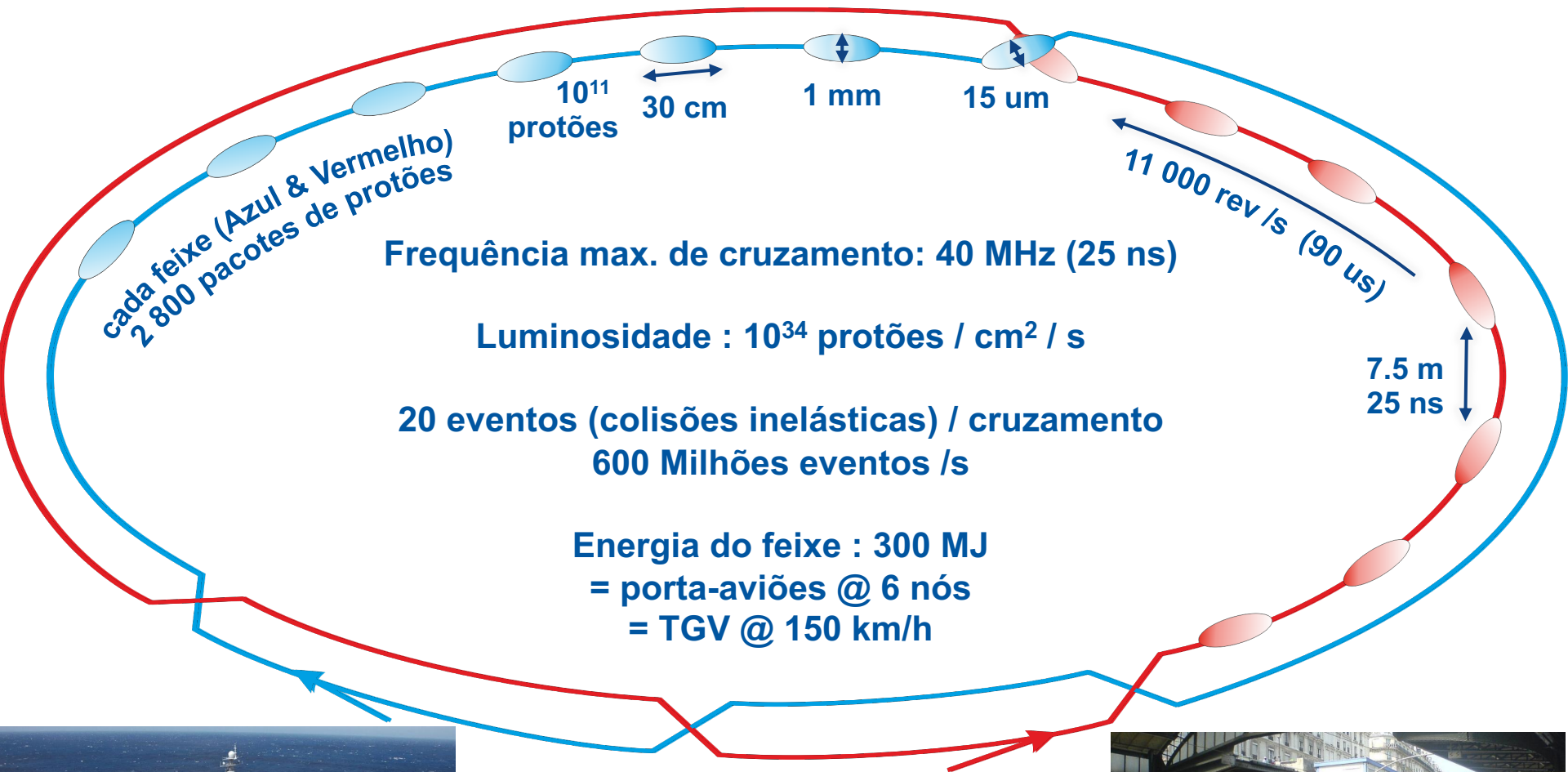

<http://lhc-machine-outreach.web.cern.ch/beam.htm>



LHC : colisionador de protões (& iões) : 27 km

8 sectores de 3.3 km

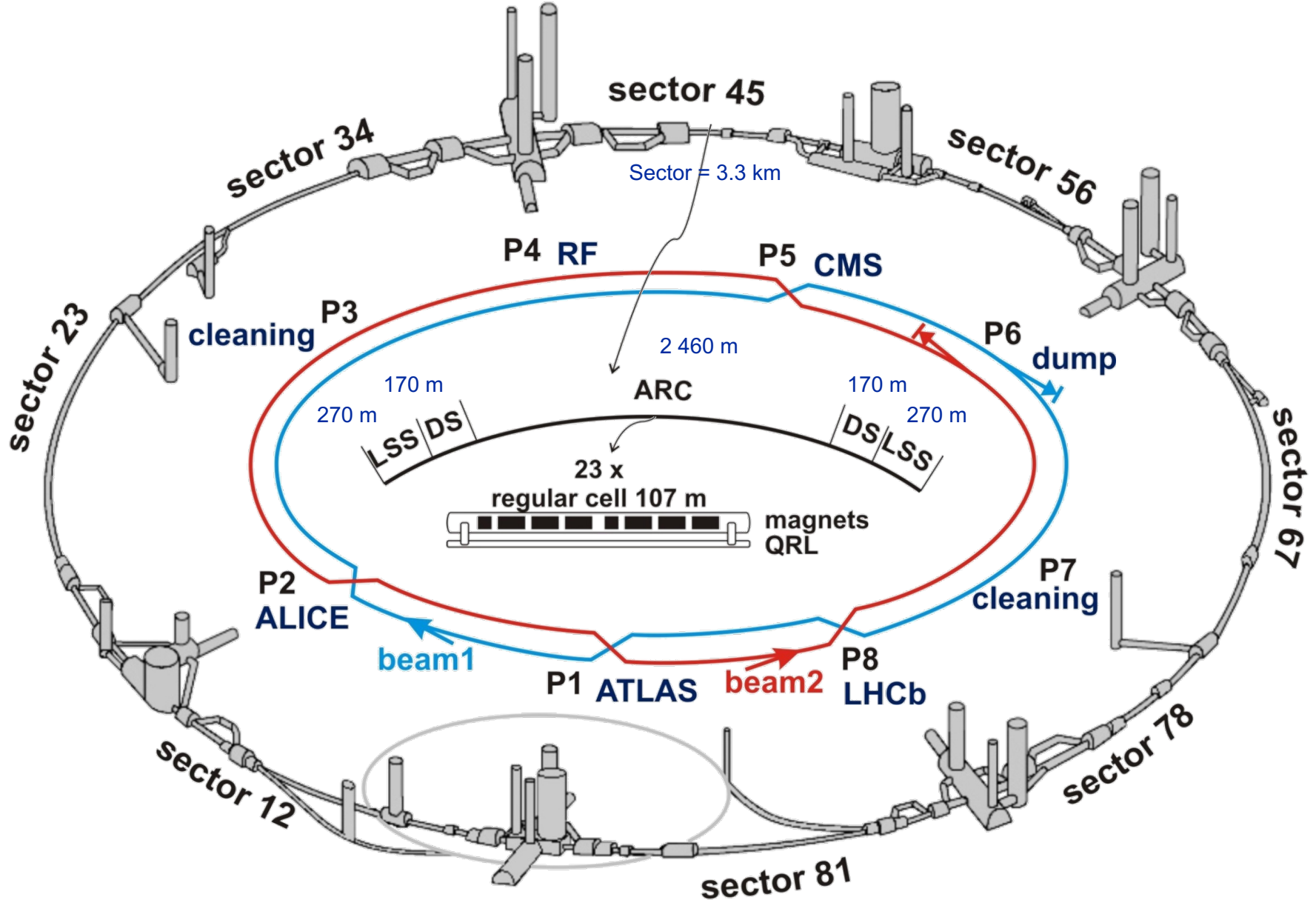

os aceleradores do CERN
criogenia para quê
vácuo para quê
instrumentos e controladores
arquitectura de controlo

guiar o feixe : ímãs supercondutores

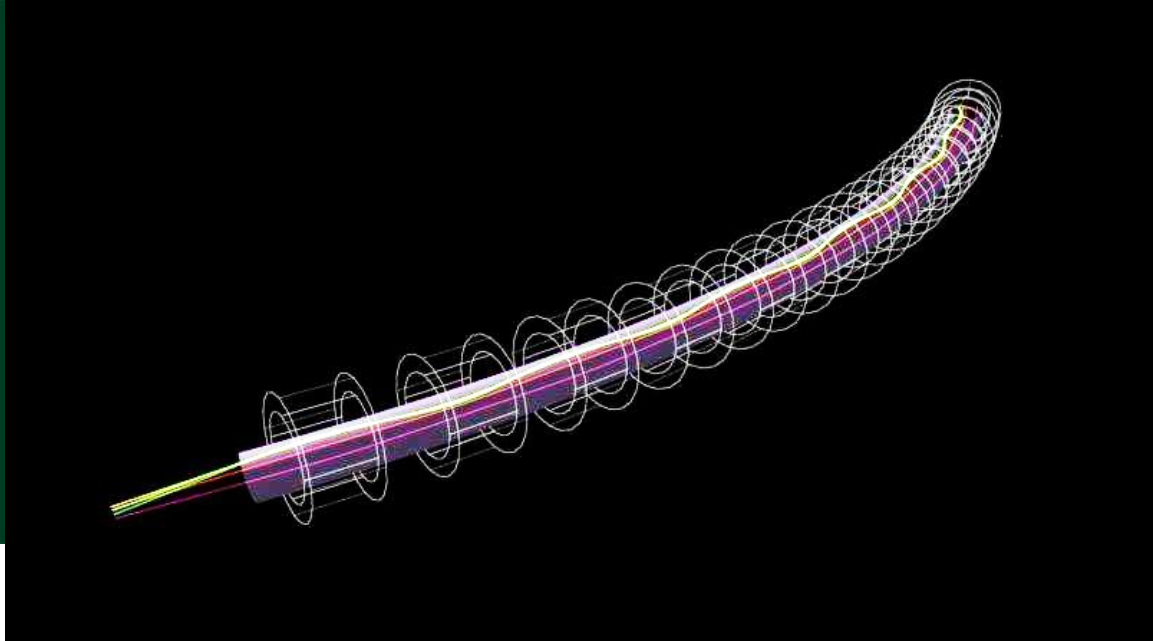
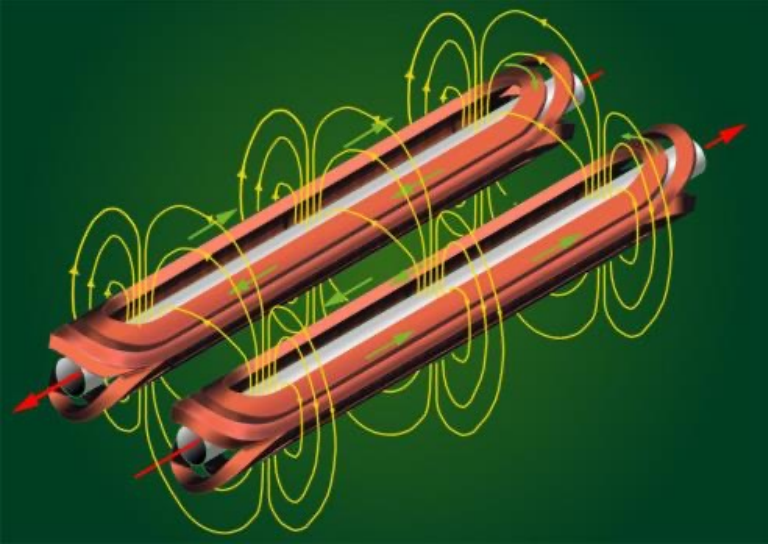

energia dos prótons : 7 TeV
campo magnético dipolos : 8 T
corrente nas bobines : 12 kA

super-condutividade necessária
bobinas de tamanho reduzido
zero resistência eléctrica

1200 D + 400 Q + 6 000 Correctr
NbTi @ 1.9 K (= -271 C) (T_c = 10 K)



<https://home.web.cern.ch/science/engineering/pulling-together-superconducting-electromagnets>

<https://home.web.cern.ch/science/engineering/superconductivity>

acelerar o feixe : cavidades supercondutoras

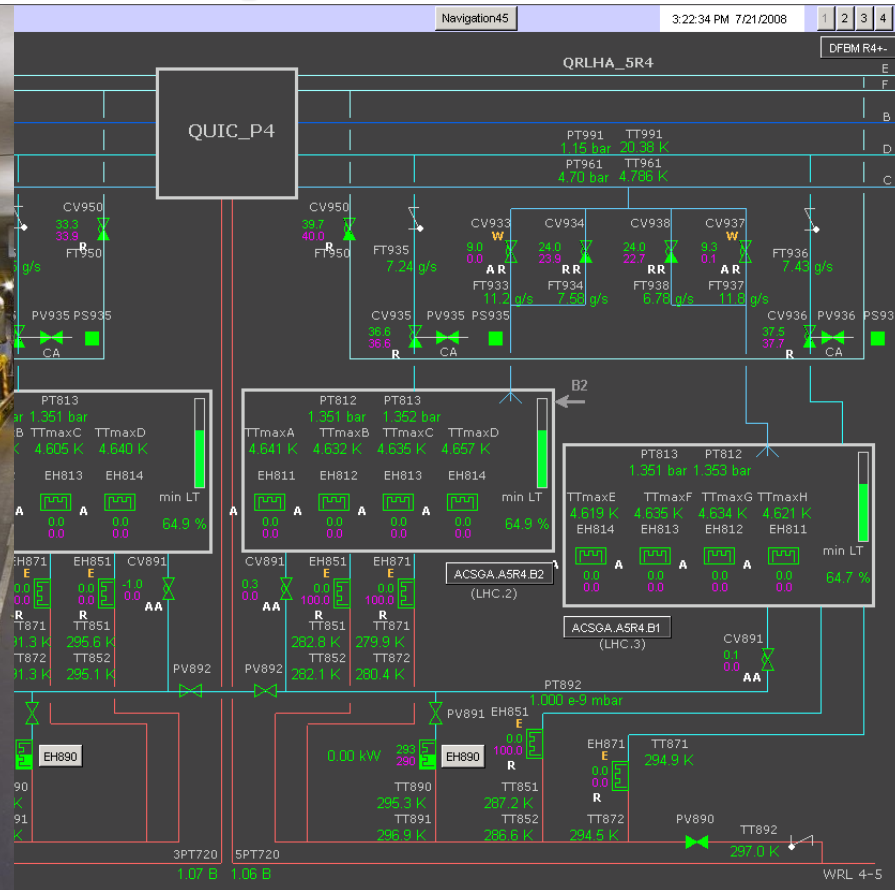
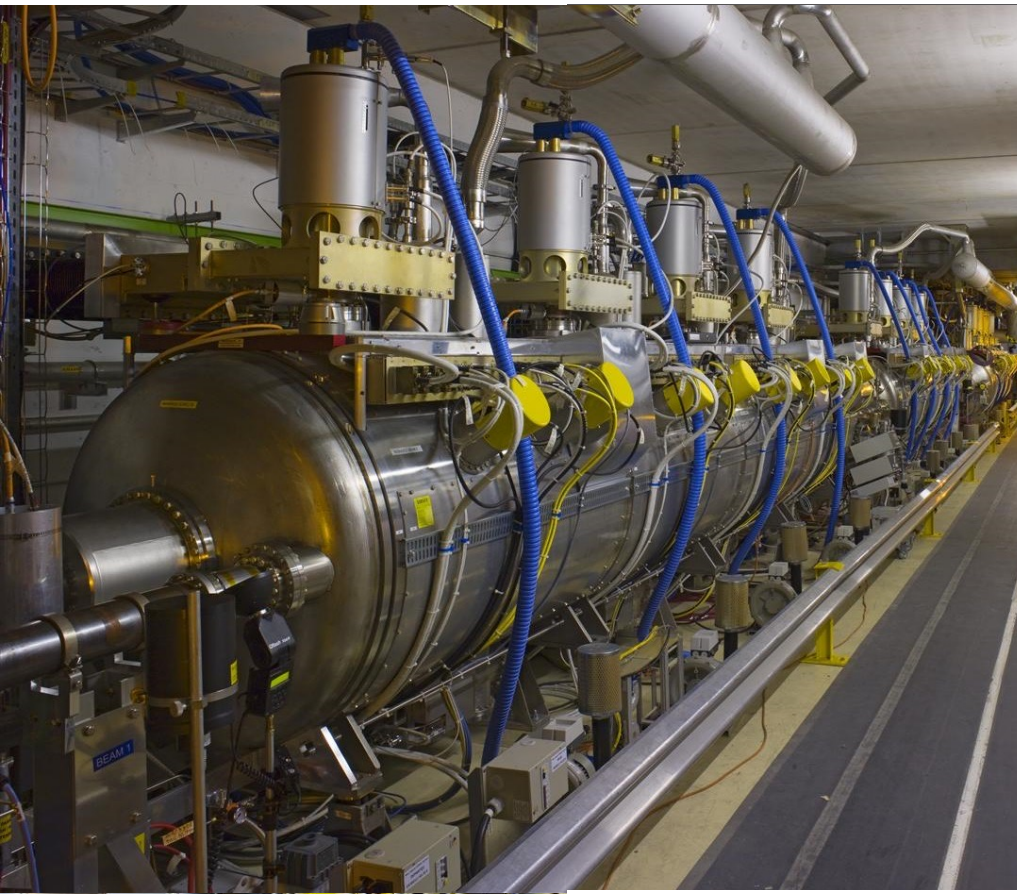

aumentar a energia do feixe: 0.45 → 7 TeV (em 20 min)

RadioFrequencia 400 MHz (ondas electromagnéticas de 2.5 ns)
espaçamento entre pacotes de prótons = 10 ondas = 25 ns = 7.5 m

16 cavidades RF @ 4.5 K (4 grupos de 4, no IP4)

Criogenia no LHC

<https://home.web.cern.ch/science/engineering/cryogenics-low-temperatures-high-performance>

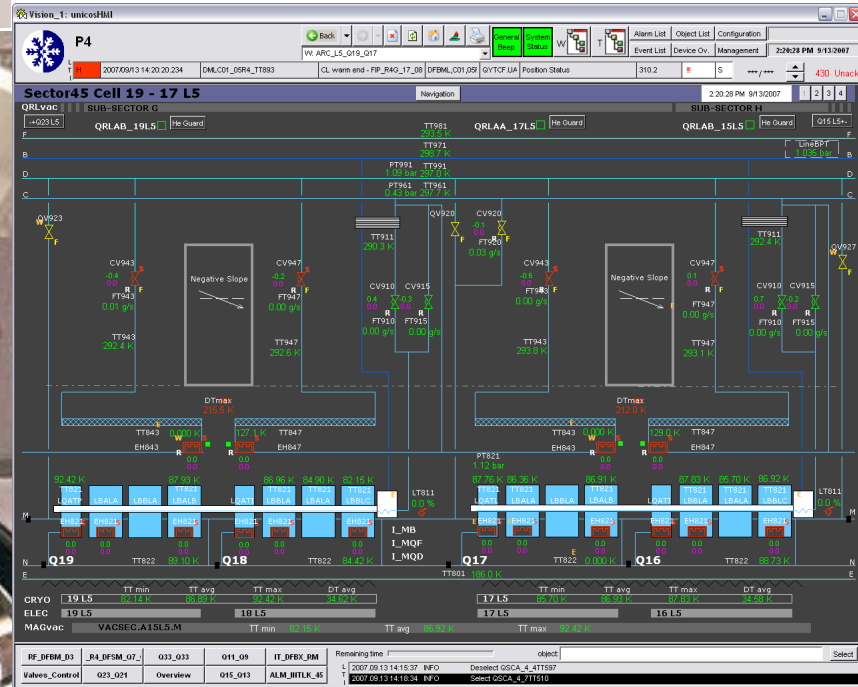
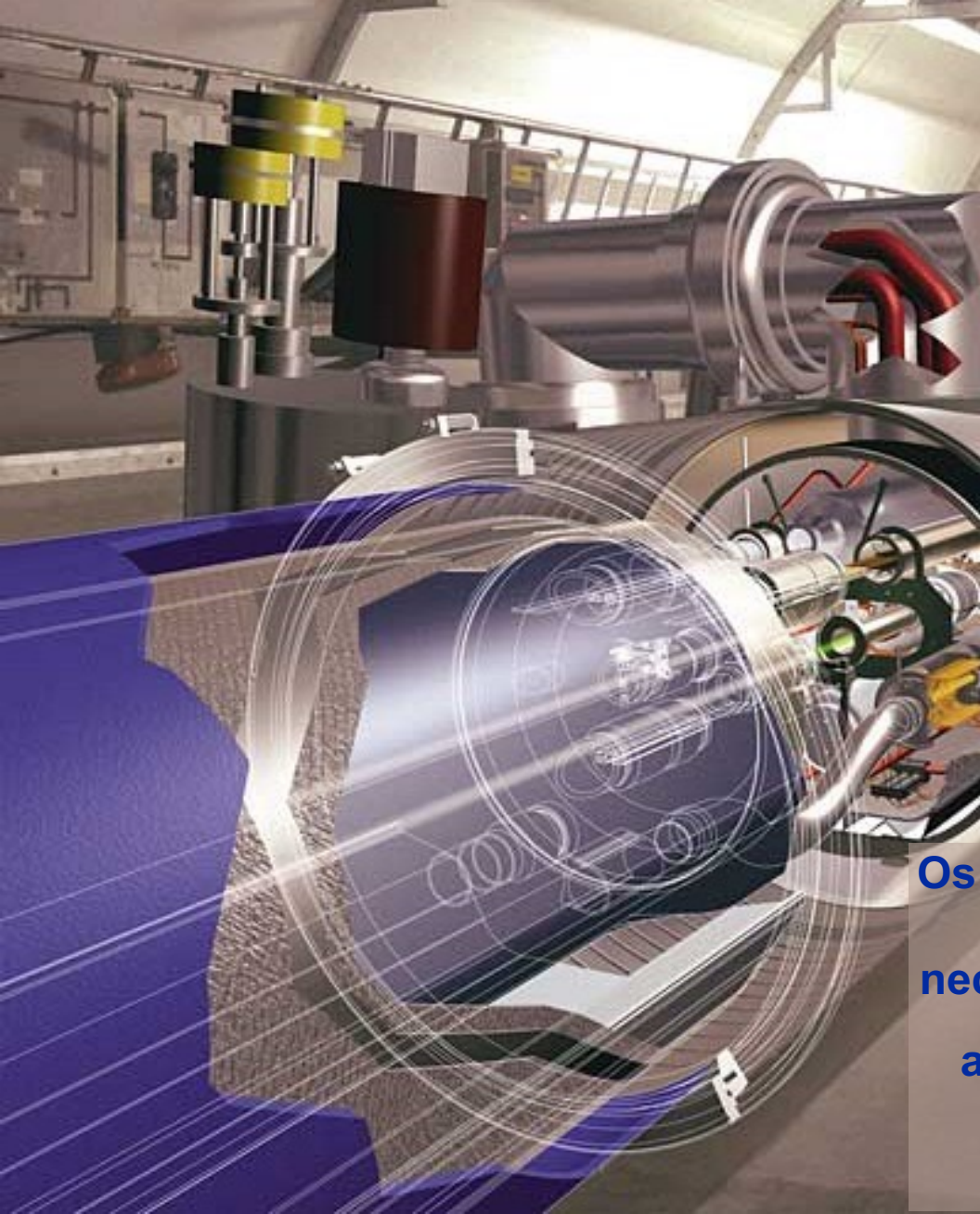

Os campos electromagnéticos enormes para guiar e acelerar as partículas necessitam materiais super-condutores arrefecidos por hélio @ 1.9 K ou 4.5 K (alta condutividade térmica)

⇒ Criogenia : 15 000 instrumentos

a
r
q
u
i
t
e
c
t
u
r
a

CRYO-SCADA
PVSS data server



CIET
PVSS data server



CERN Control Centre

2 PLC
Siemens S7-400
500 ms cycle



Ethernet
Technical Network



surface - local control room

8 FEC
WorldFIP – Ethernet
Gateway
500 ms cycle

100 m

4x Profibus
1.5 Mbit/s

100 m

4x WorldFIP
1 Mbit/s

alcoves - radiation free

“intelligent”
CV positioners
with electronics



point-to-point
cables

FieldBuses ← large distances
industrial electronics → protected areas
CVs → electronics moved into protected areas
front-end electronics → radTol custom made

accelconf.web.cern.ch/AccelConf/icaleps2009/posters/wep061_poster.pdf
accelconf.web.cern.ch/AccelConf/icaleps2009/papers/wep061.pdf

180
cryogenic CV
without electronics



tunnel - radiation



100
FIP crates
custom rad-tol electronics

sector = 3.3 km



base de dados

ICALEPCS 2011 poster : <https://cernbox.cern.ch/public.php?service=files&t=8d49fd498d38f9fb0a7824ba93afc09a>

ICALEPCS 2011 paper : <http://accelconf.web.cern.ch/AccelConf/icalepcs2011/papers/mopkn024.pdf>

17 000
instrumentation
channels

800 FIP crates
900 cards

1 700 Profibus
components

5 000 cable
numbers

LHC Layout Database

specification files
for manufacturing
FIP Crates

cabling files for
connecting &
inspecting cables

XML files for
Mobile Test Bench

specifications for
control software
PLC , FEC, SCADA

Crates	Channels
17 000	

Crates	Channels
800	

XML Files
1 700

Specifications
5 000





pessoal do frio



os aceleradores do CERN
criogenia para quê
vácuo para quê
instrumentos e controladores
arquitectura de controlo

Vácuo : isolamento térmico para a Criogenia

Para isolar as temperaturas extremamente baixas (cavidades RF, ímans, linhas de distribuição de helio)

a criogenia necessita de vácuo (podemos começar a arrefecer quando o vácuo atinge a 10^{-1} mbar)

Abaixo de 20 K (-250 C), o frio dos metais é suficiente para manter o vácuo a 10^{-7} mbar

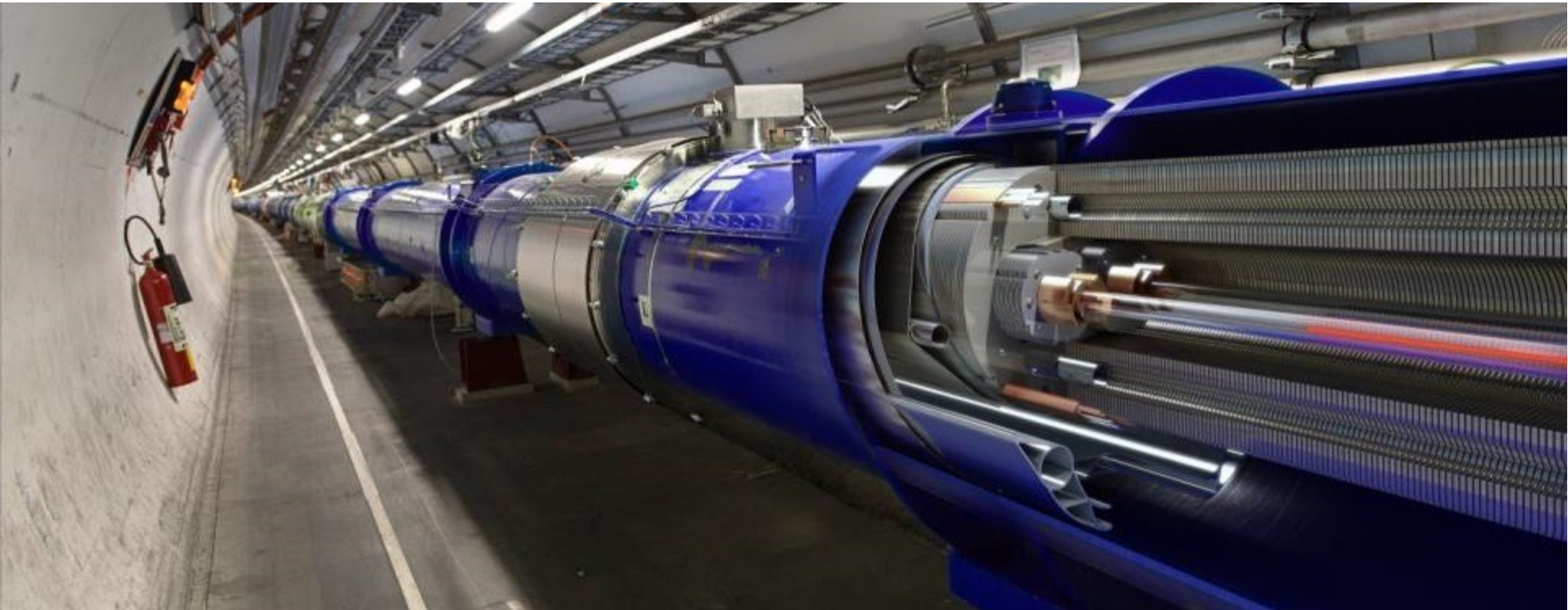

Vácuo : deixem passar as partículas

LINAC_2: 50 MeV



PS_Booster: 1.4 GeV

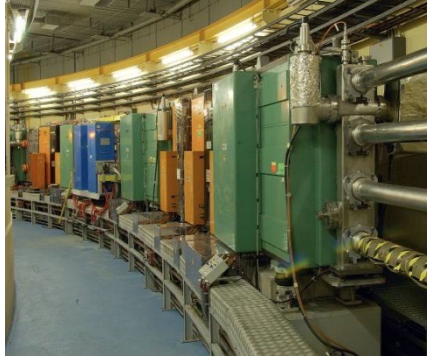

PS: 26 GeV

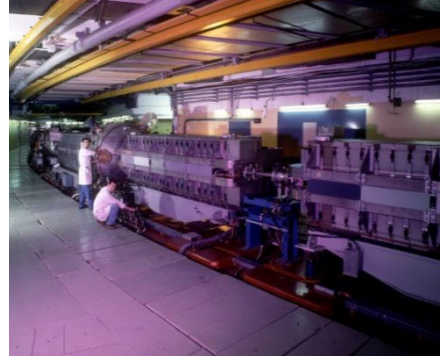

SPS: 450 GeV



Em qualquer acelerador, o vácuo é necessário para :
reduzir as colisões entre as partículas aceleradas e as moléculas do ar
maximizar a duração do feixe ($100\text{h} : 10^{-8} \text{ mbar}$)

LHC: 7 000 GeV

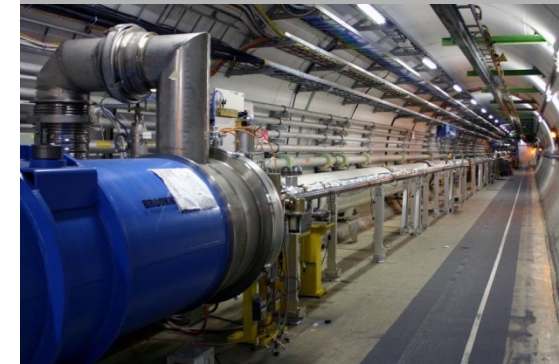

minimizar o ruído de fundo para as experiências (10^{-11} mbar)

<https://home.web.cern.ch/science/engineering/vacuum-empty-interstellar-space>

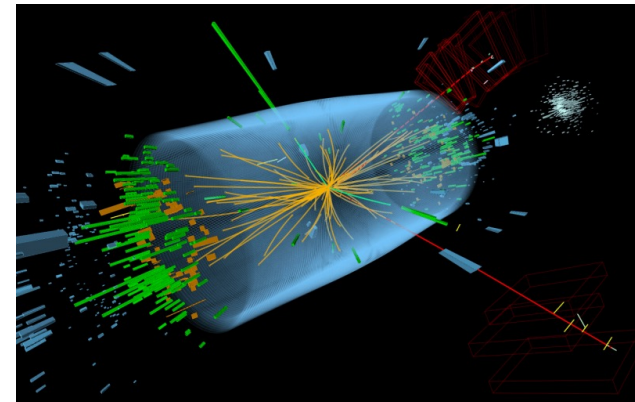

gammas de pressão de vácuo (15 décadas)

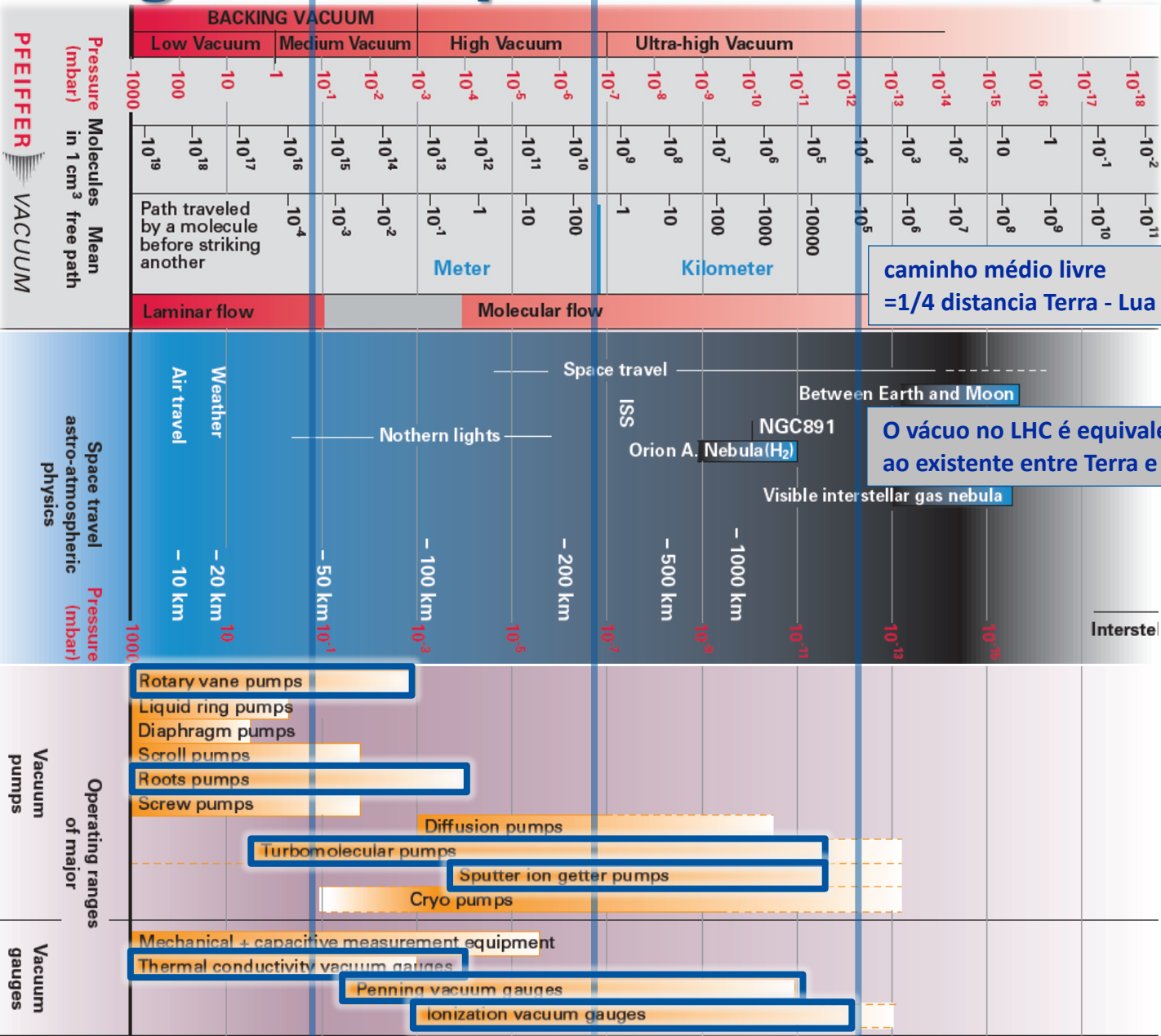

LHC Insulation Vacuum
 $P < 10^{-1}$ mbar
 VAC_OK for cool-down

@T < 20 K : cryo-pumping
 $P \sim 10^{-7}$ mbar

Beam Vacuum
 $P \sim 10^{-9} \dots 10^{-12}$ mbar

caminho médio livre = 1/4 distancia Terra - Lua

O vácuo no LHC é equivalente ao existente entre Terra e Lua



primary /roughing pumps
 $10^{+3} \dots 10^{-2}$ mbar

turbomolecular pumps
 $\dots 10^{-11}$ mbar

sputter ion pumps
 $10^{-5} \dots 10^{-11}$ mbar

pirani gauges
 $10^{+3} \dots 10^{-4}$ mbar

Penning gauges
 $10^{-5} \dots 10^{-11}$ mbar

Bayard-Alpert gauges
 $10^{-5} \dots 10^{-12}$ mbar



os aceleradores do CERN
criogenia para quê
vácuo para quê
instrumentos e controladores
arquitectura de controlo

sensores Pirani (thermal conductivity)

1 bar .. 10^{-4} mbar

A condutividade térmica de um gas depende da sua pressão

Uma resistência eléctrica é aquecida a temperature constante ($\sim 120\text{ }^\circ\text{C}$)

A corrente eléctrica necessária para manter essa temperatura

é proporcional à pressão do gás

(maior pressão = maior condutividade = maior dissipação)

Acima de 1mbar deixa de ser linear e depende do tipo de gas

Precisão $\sim 30\%$

Necessita calibração para compensar comprimento do cabo elétrico

Sensível à temperatura ambiente

cabo de pares torcidos
blindagem simples

$\sim 500\text{m}$

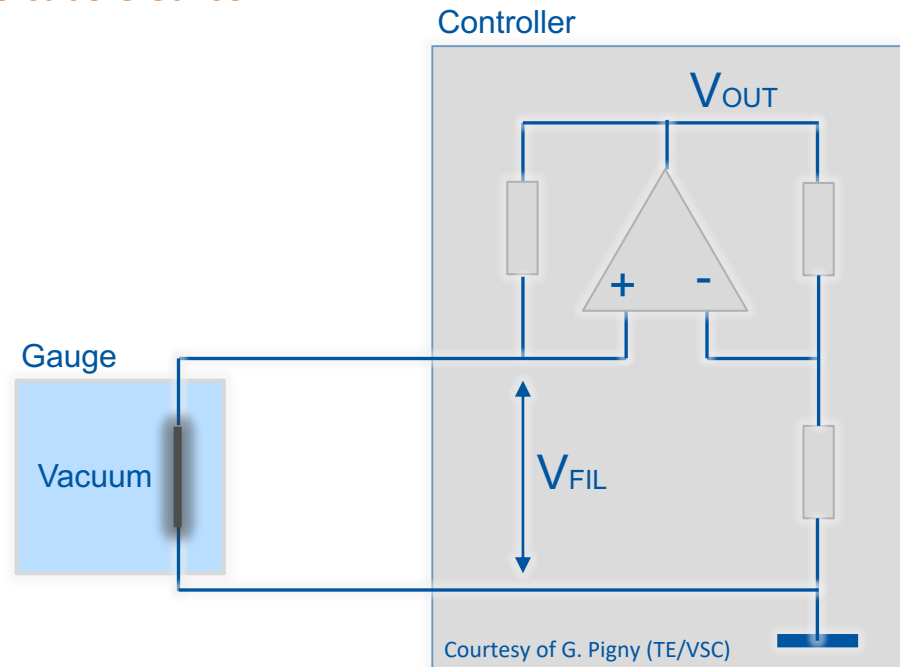
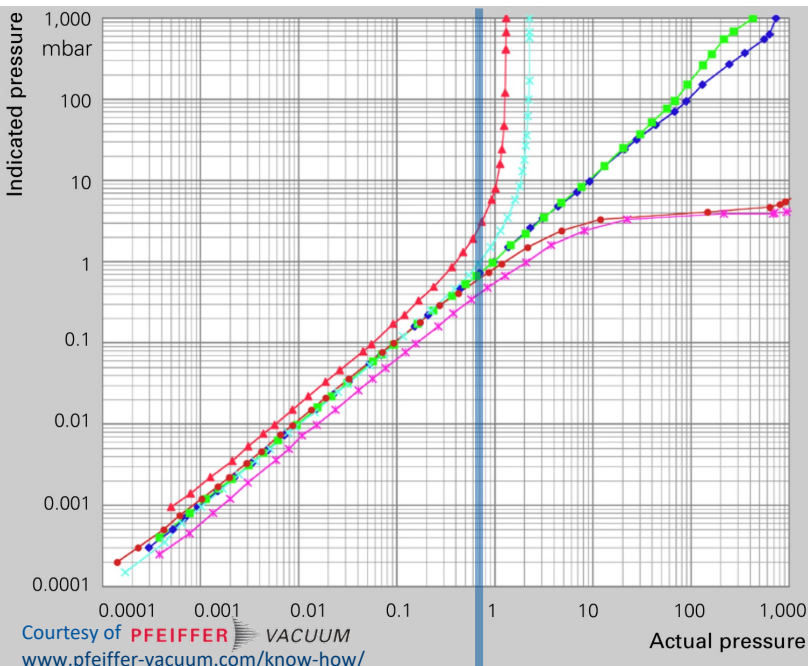

sensores Penning (cold cathode ionization)

$10^{-5} .. 10^{-11}$ mbar

Elétrões são emitidos do cátodo graças a campo elétrico de 3 kV

Um campo magnético (0.1 T) faz com que os elétrões percorram uma longa espiral até chegarem ao ânodo, aumentando assim a probabilidade de chocar e ionizar moléculas de gás

As moléculas de gás ionizadas são atraídas para o cátodo e a corrente gerada é uma medida da pressão (entre 1uA e 1pA)

Precisão ~ 50%

Pressão elevada : corrente instável (produção de arco eléctrico)

Pressão baixa : corrente extingue-se (leitura zero)

Cabo interrompido = leitura zero

= indicação errada de baixa pressão

Mau isolamento da alta tensão = corrente de fuga

= indicação errada de alta pressão

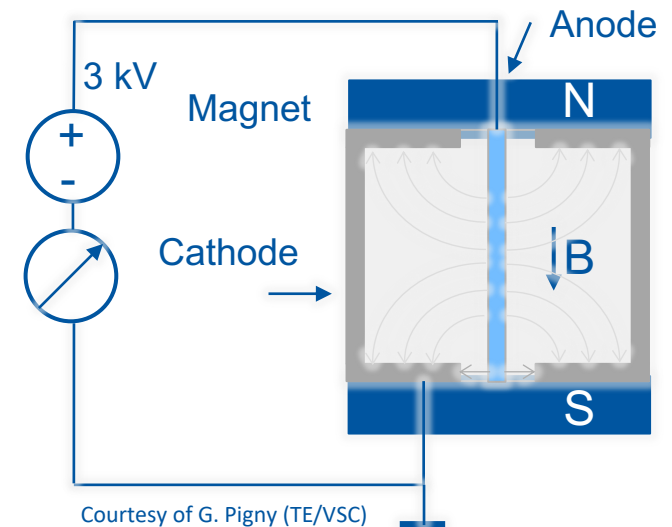
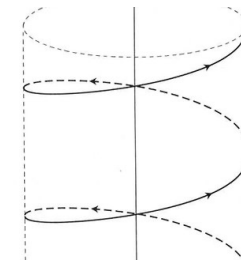

sensores Bayard-Alpert (hot cathode ionization)

$10^{-5} \text{ .. } 10^{-12} \text{ mbar}$

Elétrões são emitidos pelo filamento aquecido (não necessitando campo elétrico elevado)

Campo elétrico (150 V) dentro da grelha cilíndrica faz com que os electrões percorram longo caminho, aumentando assim a probabilidade de chocar e ionizar moléculas de gás

As moléculas de gás ionizadas são atraídas para o colector e a corrente gerada é uma medida da pressão (entre 1uA e 0.1pA)

Precisão ~ 10%

Necessita calibração

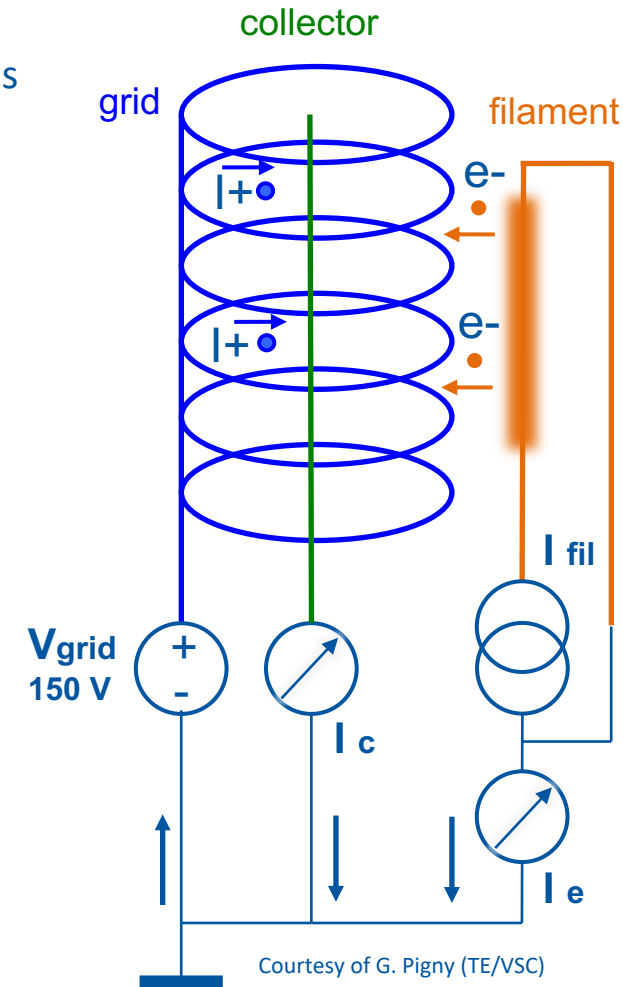
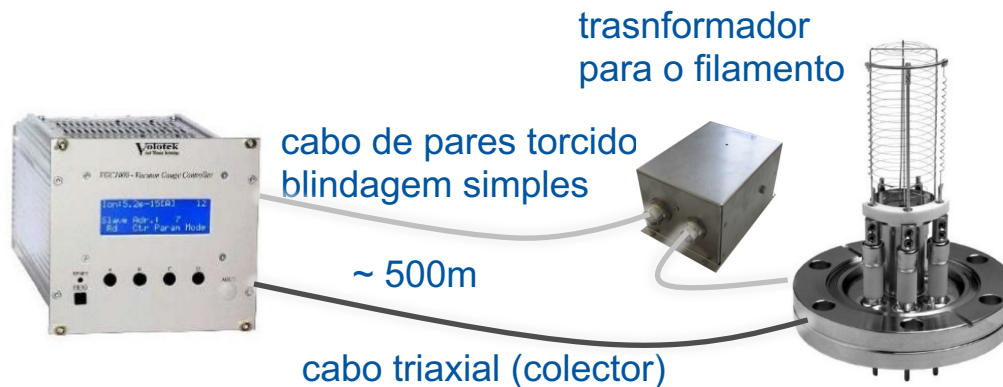

Bombas primárias

1 bar .. 10^{-2} / 10^{-4} mbar

Velocidade de bombagem : alguns m^3/h

Utilizadas para bombear a partir da pressão atmosférica
ou como auxiliares de bombas turbo-moleculares

Bombas húmidas (ex. **Rotary vane**)

usam óleo para vedar, lubrificar e refrigerar

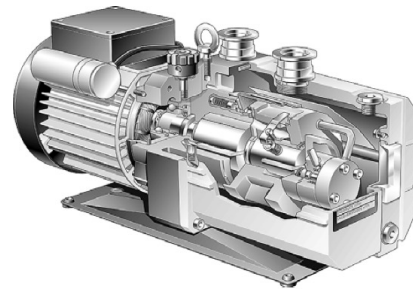
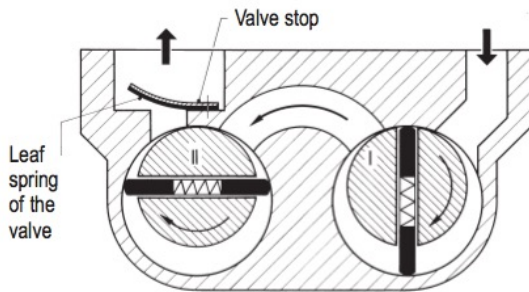

I High vacuum stage
II Second forevacuum stage

Courtesy of Oerlikon-Leybold
<http://www.oerlikon.com/leyboldvacuum/en/documents/download-documents/>

Bombas secas (ex. **Roots**)

são mais ecológicas
necessitam de grande precisão mecânica

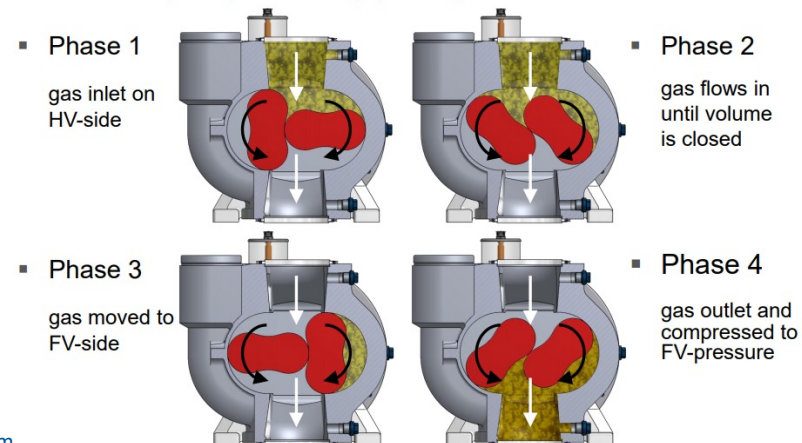

Bombas Turbo-Moleculares

$10^{-2} \dots 10^{-11}$ mbar

Velocidade de bombagem : 10 .. 3 000 l/s

O movimento rápido do rotor (30 000 - 70 000 rpm)
empurra as moléculas em direção à saída de escape

É utilizada juntamente com uma bomba primária

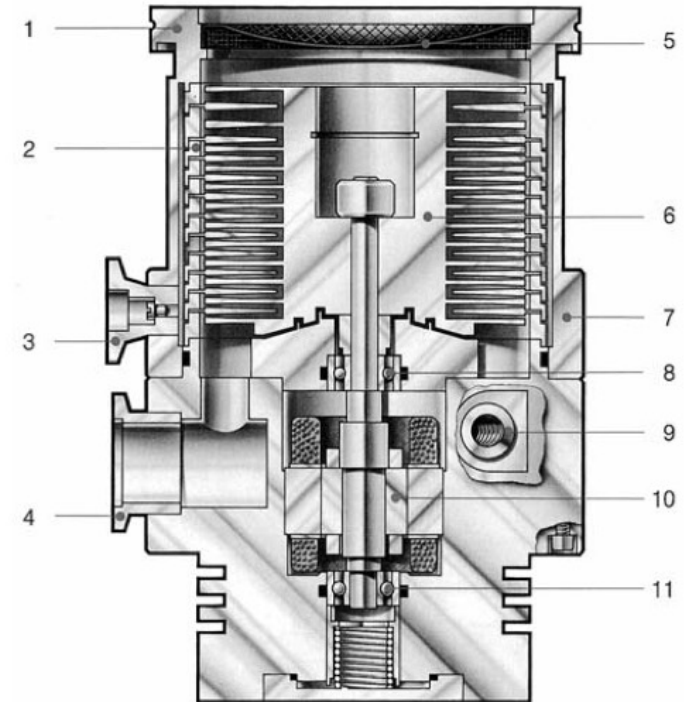
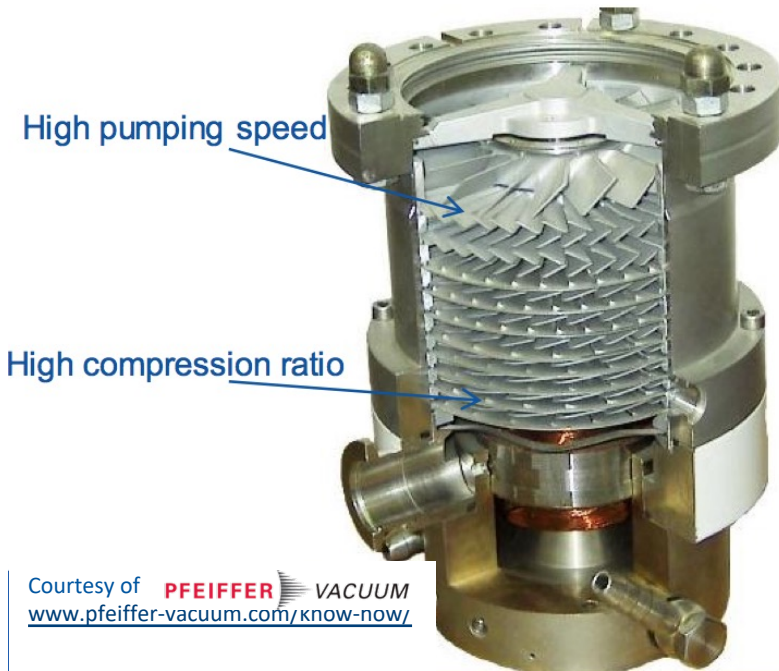

- | | | |
|----------------------------|------------------|----------------------------|
| 1 High vacuum inlet flange | 5 Splinter guard | 9 Cooling water connection |
| 2 Stator pack | 6 Rotor | 10 3-phase motor |
| 3 Venting flange | 7 Pump casing | 11 Ball bearings |
| 4 Forevacuum flange | 8 Ball bearings | |

Courtesy of Oerlikon-Leybold

<http://www.oerlikon.com/leyboldvacuum/en/documents/download-documents/>

Grupos de bombagem

Um grupo de bombagem é formado por uma bomba primária (VPP) e uma turbo-molecurar (VPT)
Sequência de funcionamento:

1. Ligar bomba primária
2. Abrir válvula intermédia (VVI)
3. Esperar até que se obtenha baixa pressão na turbo
4. Ligar a bomba turbo molecular
5. Esperar que a bomba turbo molecular atinja a velocidade nominal
6. Abrir válvulas VVR1 e VVR2

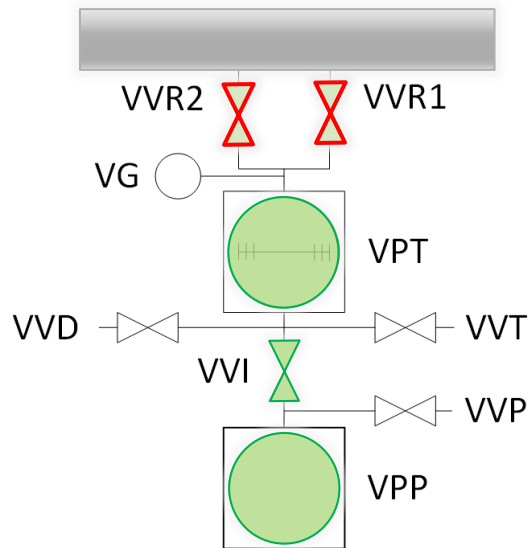

Válvulas:

VVT – Venting bomba Turbo Moléculas

VVP – Venting bomba Primária

VVD – Detecção de fugas

VVR1 e VVR2 – Ligam o grupo à câmara de vácuo

Bombas iónicas

$10^{-5} \dots 10^{-11}$ mbar

Mesmo princípio de sensores Penning - Várias células Penning em paralelo

Elétrões presos na célula devido a combinação entre campo elétrico e campo magnético

Elétrões ionizam o gás e os iões são atraídos para o cátodo

Ao colidirem com o cátodo, Ti é libertado e forma uma camada no ânodo que prende gases (adsorption)

Volume bombado é retido dentro da bomba – sem escape

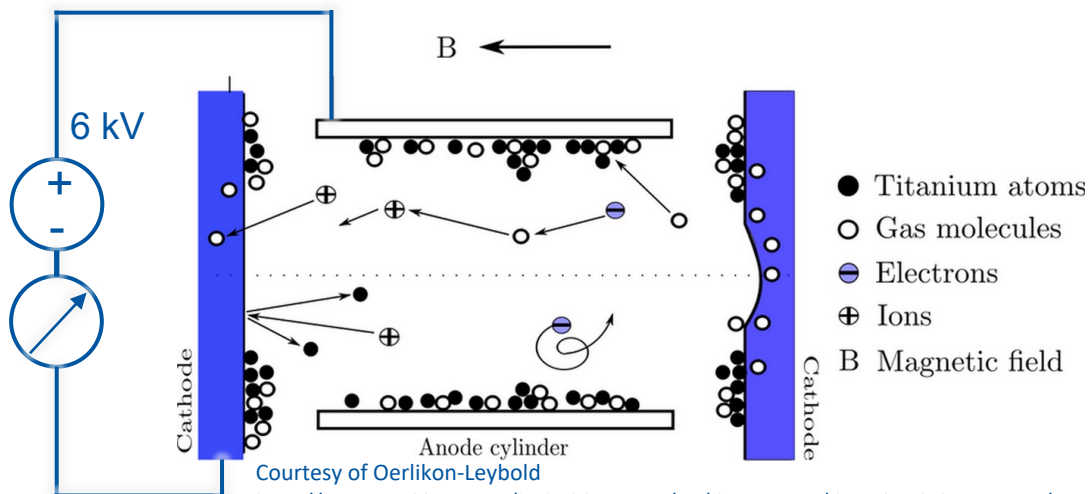

Courtesy of Oerlikon-Leybold
<http://www.oerlikon.com/leyboldvacuum/en/documents/download-documents/>

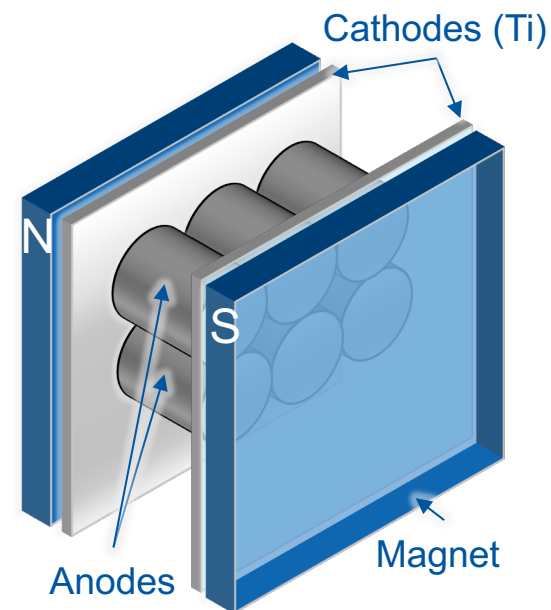
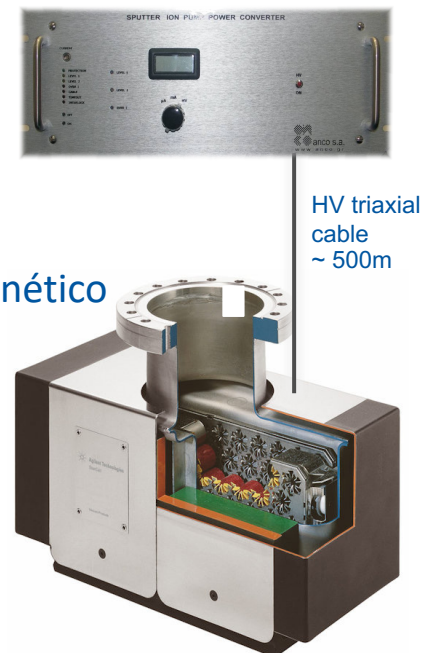

Sectorização

A instalação de vácuo está dividida em sectores (sectorizada) para:

- Isolar fugas

- Permitir intervenções sem afetar outros sectores

- Reduzir o tempo de bombagem após intervenções

A separação entre os sectores é feita através de válvulas de sector

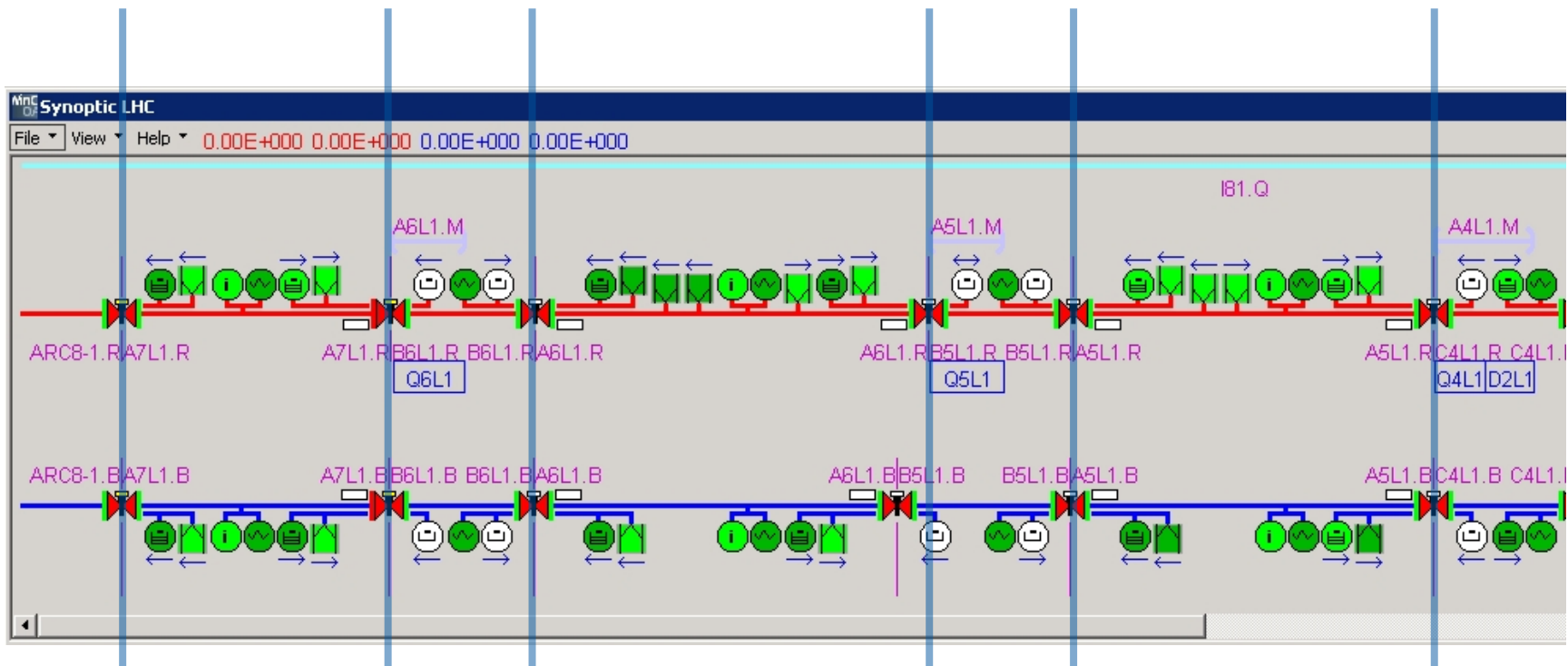

quantos instrumentos ?

Mais de **6 000** instrumentos a serem monitorizados e controlados remotamente

130 km de câmaras de vácuo

Pressão de operação : 10^{-4} .. 10^{-12} mbar

Autómatos programáveis (PLCs) : **300**

Sensores de pressão : **3 000**

Grupos de bombagem : **250**

Bombas de ionização : **2 700**

Válvulas de Sector : **500**

	L2,L3, PSB,PS	SPS	LHC beam	LHC insul.	other facilities	total
length [km]	2	16	59	50	1	128
log (P [mb])	-7..-10	-7..-9	-8..-11	-5..-7	-4..-10	-4..-11
PLC master	5	8	28		3	44
PLC other	0	10	7		0	17
PLC slave	0	0	100		155	255
VGM	0	0	10	231	0	241
VGR	102	113	428	348	61	1052
VGP	122	128	649	364	66	1329
VGF	0	13	4	0	0	17
VGI	28	0	167	0	16	211
VPGF	7	3	14	179	51	254
VPI	370	1429	825	0	69	2693
VPS	48	0	0	0	0	48
VVS	76	87	305	39	13	520
VVF	0	11	0	0	0	11
VVW	0	5	0	0	0	5

os aceleradores do CERN
criogenia para quê
vácuo para quê
instrumentos e controladores
arquitectura de controlo

a sala de controlo

1974

Sala de control do PS (Proton Synchrotron)

©CERN

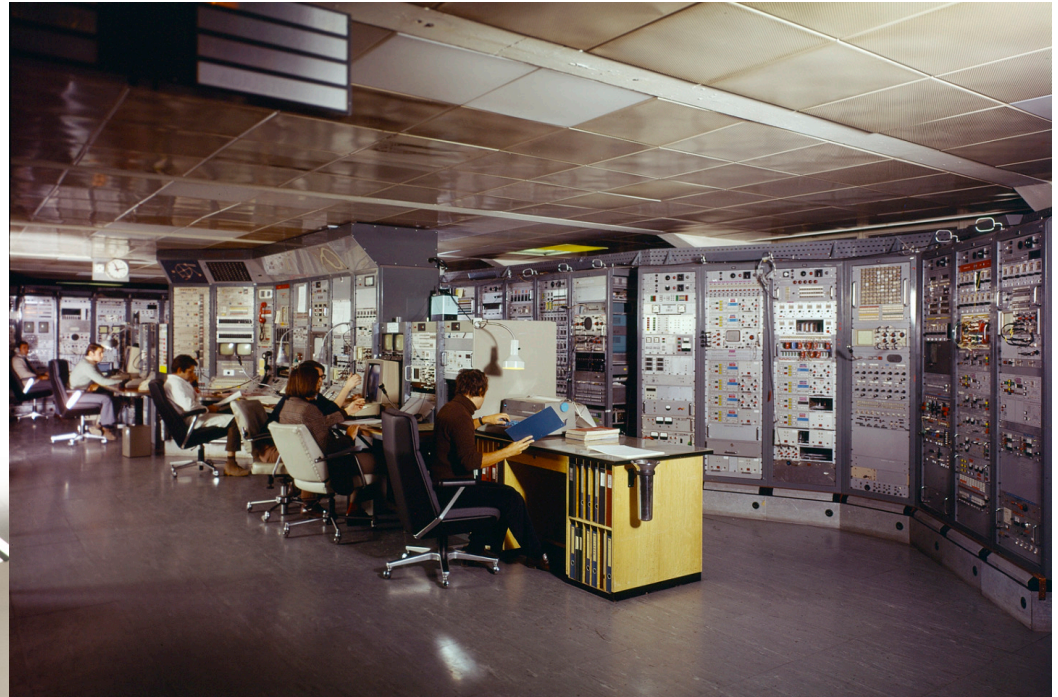

2015

Sala de control do LHC e seus injectores
CERN control centre (CCC)

©CERN

arquitectura de control para o vácuo

Supervision layer



Control layer

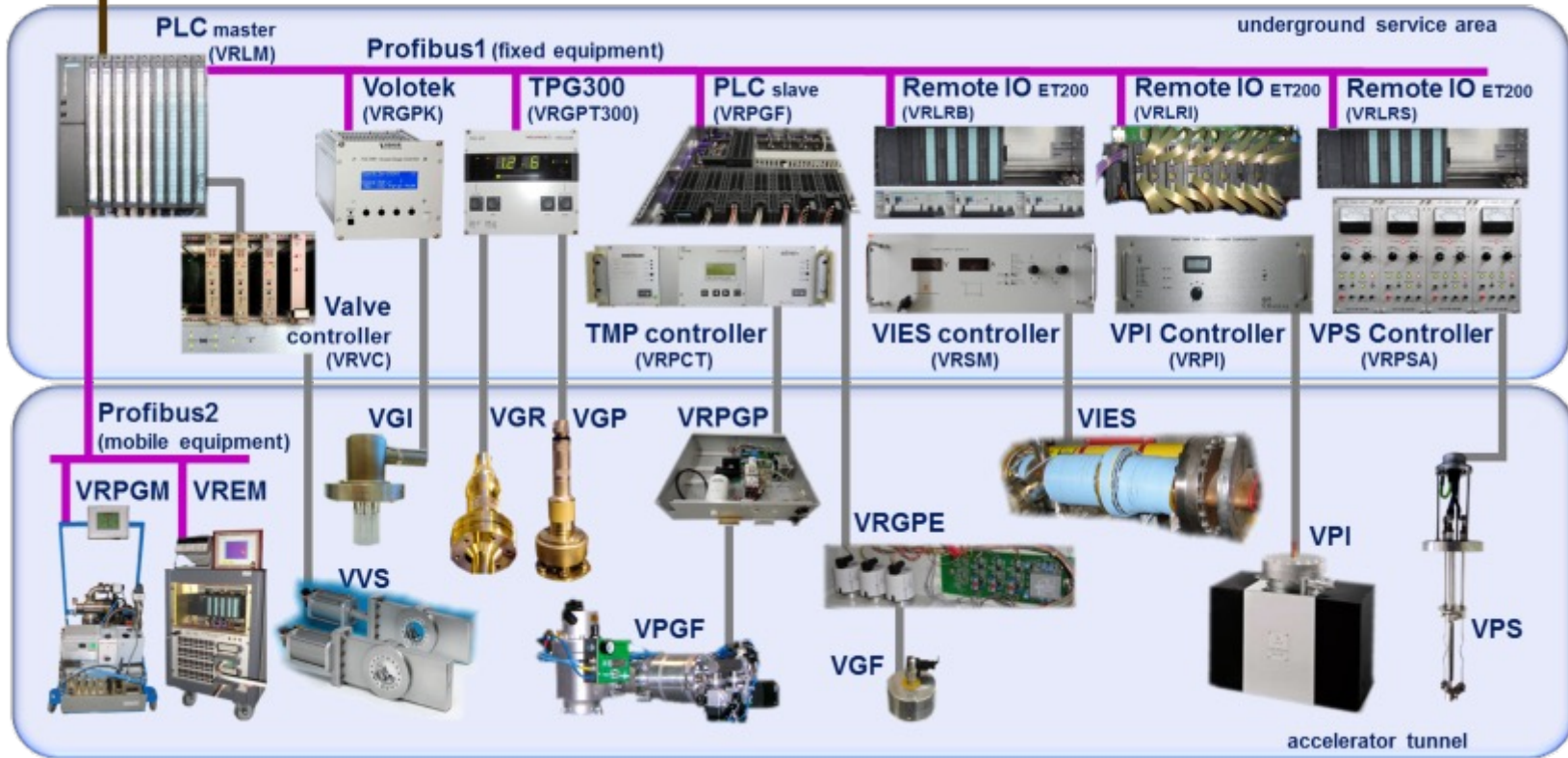

ICALEPCS 2011 poster : http://accelconf.web.cern.ch/AccelConf/icalepcs2011/posters/mopms016_poster.pdf
 ICALEPCS 2011 paper : <http://accelconf.web.cern.ch/AccelConf/icalepcs2011/papers/mopms016.pdf>



Camada de campo no túnel do acelerador

Equipamentos diretamente ligados ao processo de vácuo:

- Sensores de pressão
- Bombas
- Grupos de bombagem
- Válvulas de sector
- Etc..

Field
layer

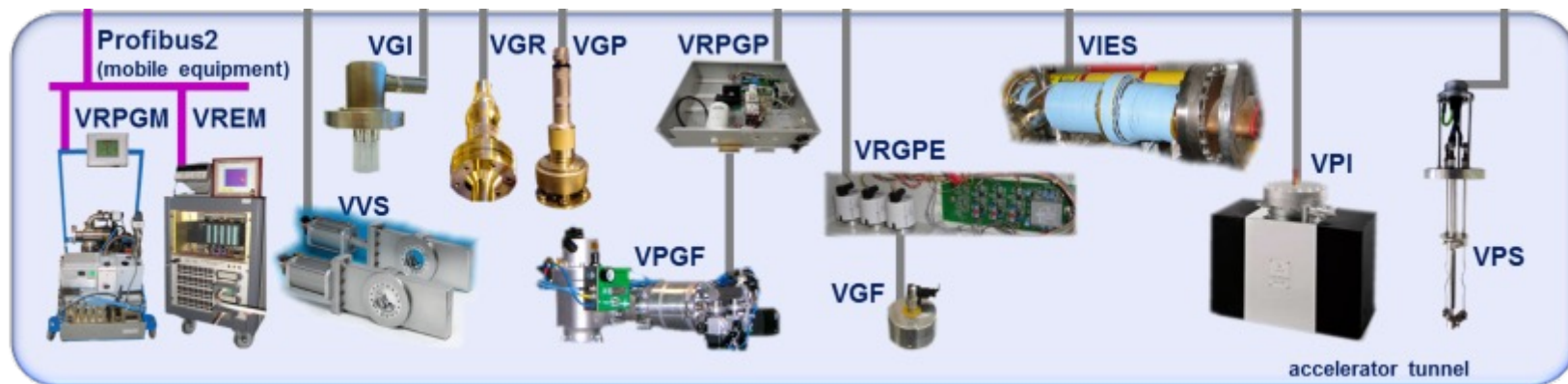

Camada de controlo nas zonas de serviço subterrâneas

Controladores de dispositivos da camada de campo

Interpretam dados analógicos de sensores e bombas e transmitem valores para PLCs

Atuam nos sensores e bombas

PLCs – Programmable Logic Controller – Computadores Industriais

Recebem informação dos controladores de equipamento

Enviam informação para a camada de supervisão

Transmitem comandos da camada de supervisão para controladores

Control
layer

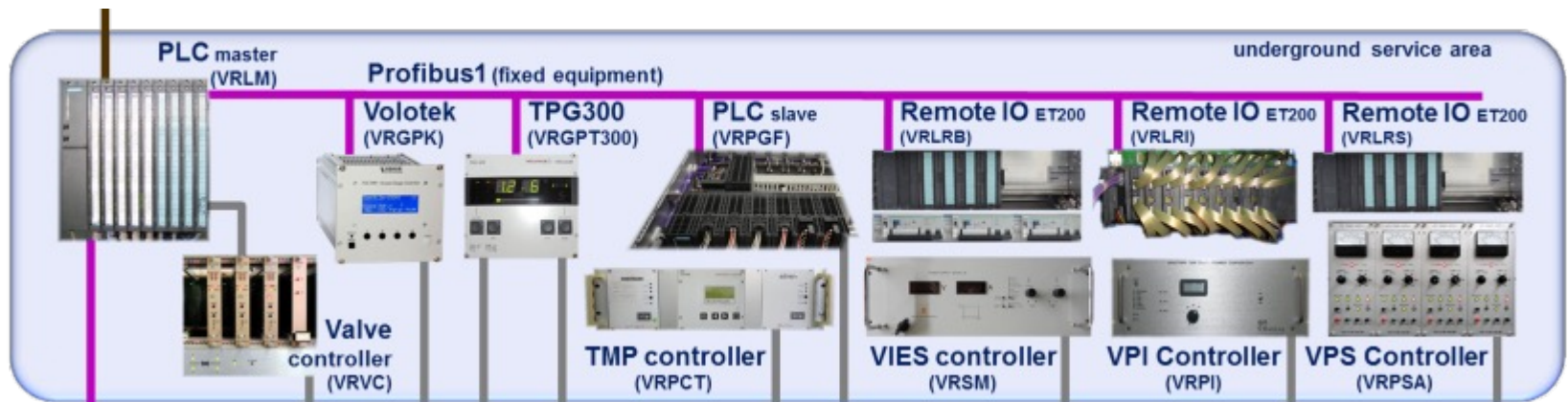

Camada de supervisão na superfície



SCADA – Supervisory Control And Data Acquisition

É o software que permite aos operadores interagirem com o sistema de controlo e também analisar o passado

Comunica em tempo real com a electrónica de controlo e com os PLCs

Representa os processos de vácuo a partir de interfaces gráficas para que operadores possam:

- Verificar o funcionamento do equipamento de vácuo
- Serem alertados em caso de anomalias
- Interagir com dispositivos

Arquivo de dados históricos:

- Permite visualizar e analisar a evolução temporal

Funcionalidades do SCADA - vistas

Vista principal de cada Acelerador

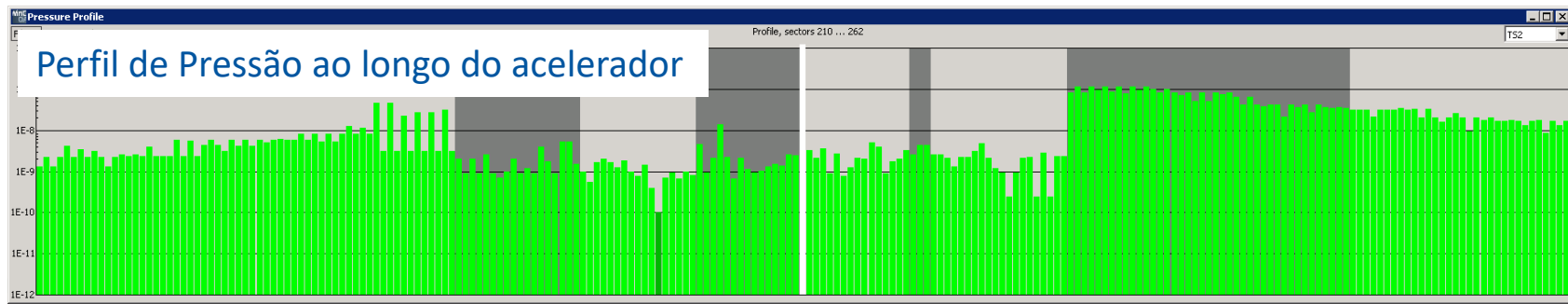
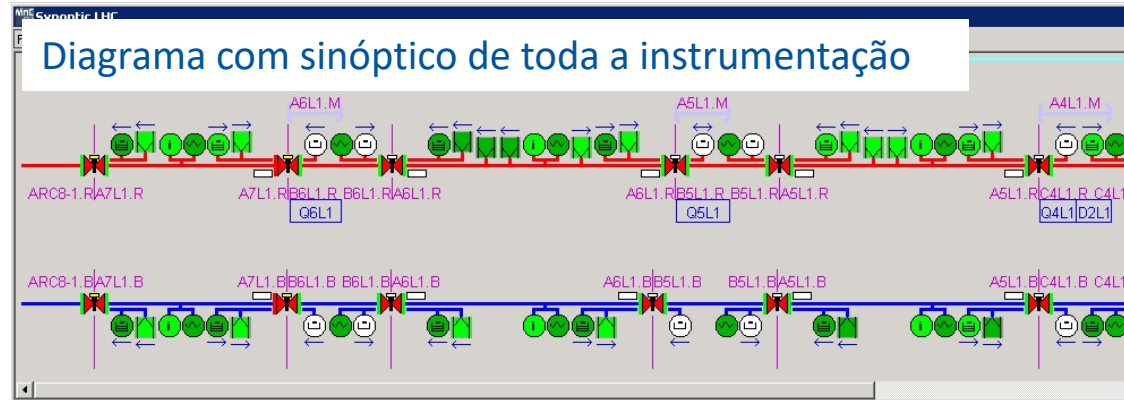
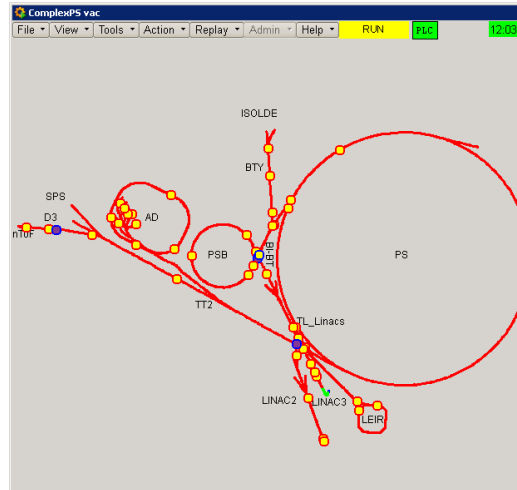
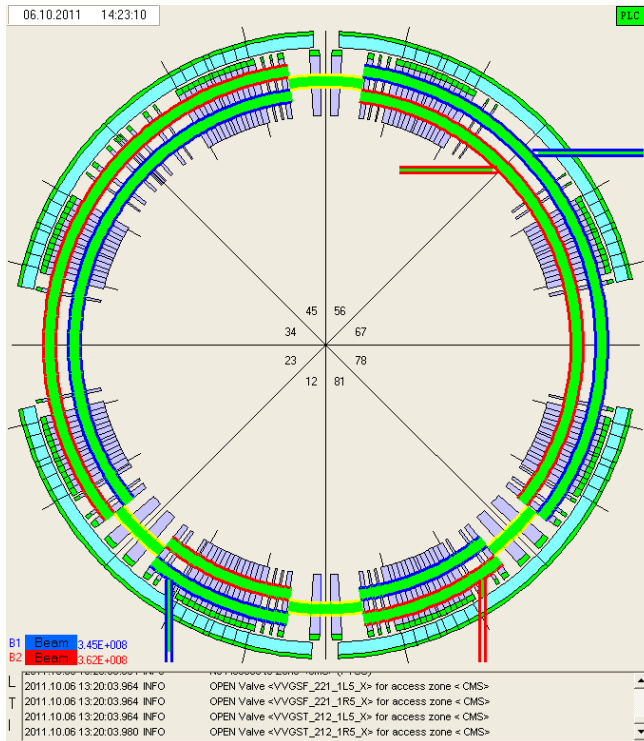

Funcionalidades do SCADA - listas

Lista de equipamentos

Equipment Types	Amount	Use
1 Valves	14	YES
2 Pirani gauges	17	
3 Penning gauges	17	
4 Ion pumps	211	
5 External interlock/alarm target	3	

Device	Sector	Pos.	State	Value	PLC	Comment
VVSA_20101	162 / 210	1181.780	Closed		M_BA2	
VVSA_21301	210 / 220	1565.750	Closed		M_BA2	
VYSB_21603	220 / 231	1662.130	Closed		M_BA2	Very small leak (1.5e-8 mbar --> 3.12e-
VYSB_21699	231 / 232	1693.080	Closed		M_BA2	
VVSE_21799	232 / 233	1725.230	Closed		M_BA2	
VVSF_21880	233 / 240	1751.180	Closed		M_BA2	
VYSB_21903	240 / 251	1758.240	Closed		M_BA2	
VVSA_210000	240 / 2002	0.000	Closed		M_BA2	
VVSA_22301	251 / 261	1885.730	Closed		M_BA2	
VVSA_23101	261 / 262	2142.830	Error		M_BA2	
VVSA_30101	262 / 311	2333.700	Closed		M_BA3	simulateur sur cette position 'fdaligau'

Alarmes por SMS

ID	Owner	Group	Configuration	Error	State	Events	fessag
16225	Imourier		Cryo alarms no filtered		Inactive	0	3
16227	Imourier		Cryo alarm		Running	122	122
16228	dcalegar		Pumping groupe LHCb BO		Inactive	0	2
16229	dcalegar		BO rack LHCb BO		Inactive	0	5
16231	gbreglio		Pumping Group Bakeout		Running	3	3
16234	gbreglio		Bake-out A6L7		Running	6	6
16235	Imourier		P> 1E-2		Running	261	266
16236	Imourier		VGP OFF or pressure is increasing		Inactive	898	582
16240	Imourier		WVR not open?		Inactive	52	52
16241	Imourier		PLC status		Running	1165	1257
16864	dcalegar		Vannes GIS et IP2		Running	168	168
16865	lkopylov		PLC is dead		Running	465	465
16866	sblancha		YPG6A Stop		Inactive	1808	333
16867	fbellori		Gas Injection Trbls		Running	54	56
16872	jsestak		C4R8 Bake-out rack WARNING		Inactive	0	30
16873	jsestak		C4R8 Bake-out rack ERROR		Inactive	0	12
16874	jsestak		C4R8 Pumping group WVR CLOSED		Inactive	0	2
17590	jdclagam		Valves_LHC		Inactive	3560	1848

Acções globais

Area Selection	Sector	Equipment	Action
PS	PR10	VGP_T (53)	Switch ON all Penning Gauges
PSB	PR20	VGR_T (34)	Switch OFF all Penning Gauges
LEIR	PR30	VPG_6AD1 (1)	Set to Auto all Penning Gauges
AD	PR40	VPI (155)	Switch all Penning Gauges ON Forced
AD_INJ_DR4_1	PR50	VPS (113)	
TL_Linacs	PR60	VVS_PS (13)	
Linac3	PR70		
BI-BT	PR80		
Linac2	PR90		
BTY	PR100		
TT2			



Funcionalidades do SCADA - histórico

Histórico de estados

State_History: StateArchiveDetails

From: 01-02-2016 15:05:22 To: 02-03-2017 15:05:22

Show Print... Save... Show controller names

Time	State	Controller
01-03-2017 10:47:39	ON	VGPB.4.6L5.R
01-03-2017 10:47:41	ON	VGPB.4.6L5.R
01-03-2017 10:53:23	OFF	VGPB.4.6L5.R
01-03-2017 10:53:58	ON	VGPB.4.6L5.R
01-03-2017 11:48:42	OFF	VGPB.4.6L5.R
01-03-2017 12:02:54	OFF	VGPB.4.6L5.R
01-03-2017 12:02:56	ON	VGPB.4.6L5.R
01-03-2017 12:03:14	ON	VGPB.4.6L5.R
01-03-2017 15:30:07	ON	VGPB.4.6L5.R
01-03-2017 15:30:09	ON	VGPB.4.6L5.R
01-03-2017 15:30:14	ON	VGPB.4.6L5.R
01-03-2017 18:31:41	ON	VGPB.4.6L5.R

VGPB.4.6L5.R Error: Warning:

LOCKED	VALIDITY	REMOTE	Auto	ON
ERRORS	WARNINGS		Protected	PR Valid ON OFF
0<Error Code<3	Pres High	OFF	No action W3	Overrange Underrange Self Prote

Close Help

Histórico de pressões

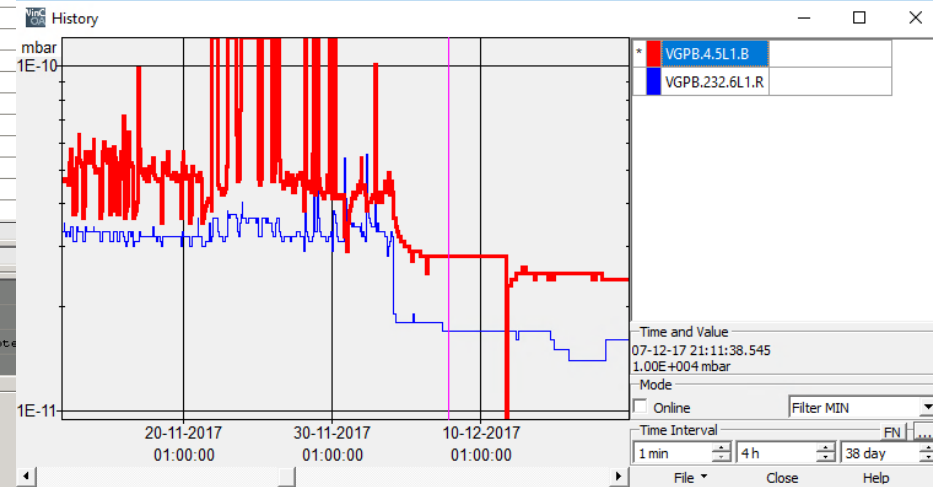

Replay

ReplayModule: Replay Control

28-02-2017 02-03-2017

Start time 02-03-2017 11:50:29 359 Duration 0 days 1 hours

Play Mode Time Driven Display data every 1 min 0 sec

2017.03.02 12:50:29.000

Close Help

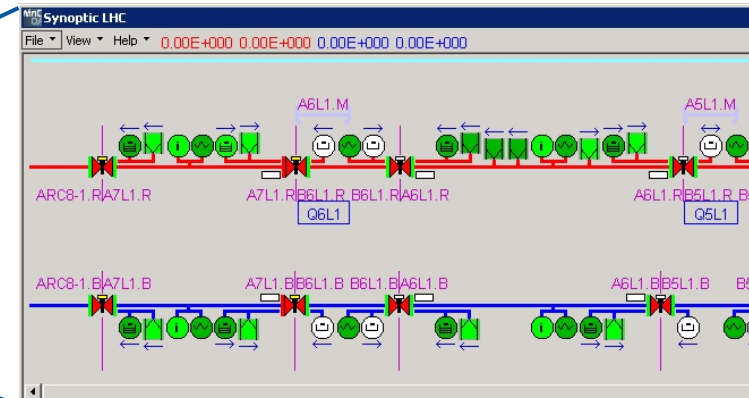

Arquivo histórico

2 anos de arquivo histórico de vácuo estão disponíveis no SCADA

Aquisição de dados para todos os equipamentos 1 Hz

Não se pode guardar tudo:

- O armazenamento de dados é limitado

- O tempo de acesso aos dados aumenta com a quantidade de dados

- Não interessa guardar ruído

Valores **Analógicos** (Pressões, correntes, temperaturas)

- São sujeitos a filtro (deadband)

- Filtro pode ser configurado individualmente por equipamento

- Filtro pode ser ajustável automaticamente para limitar os equipamentos mais ruidosos

Valores **Digitais** (Estado de dispositivos, Código de erro, Código de aviso, Alarmes)

- Todos os valores são interessantes !

- São guardados sem filtragem

Technical recommendations for control systems

Quality of connectors, grounding and cables are essential for reliable **measurements**

For **low current measurement** (pA, fA), several external factors can strongly affect the results

Interlocks and alarms must be reliable and tested extensively to assure the machine protection

Electronics shall be tested under **radiation** before to be installed in radiation areas

Wireless network can be used with mobile equipment to improve time intervention and cost

Choose your SCADA **software** carefully

If your control system is moderately large – **automate** configuration

Distribute your applications between **servers** wisely

Protect your control system by having your SCADA on a dedicated, **secured network**

Conclusão

O LHC é precedido por uma cadeia de aceleradores de dimensões e energia crescentes

Como guiar e acelerar o feixe de partículas

O LHC necessita criogenia e vácuo

Gamas de pressão :

diferentes tipos de sensores e tipos de bombas são utilizadas segundo os níveis de pressão

O sistema de vácuo está dividido em sectores (sectorizado)

A arquitectura do sistema de controlo do vácuo do CERN tem 3 camadas (campo , controlo , supervisão)

O SCADA é o software que permite aos operadores interagirem com o processo e analisar o passado

Nem todos os valores históricos são armazenados :

Valores analógicos: filtros permitem arquivar apenas o essencial

Todos os valores de estado são armazenados

peçoal do vazio

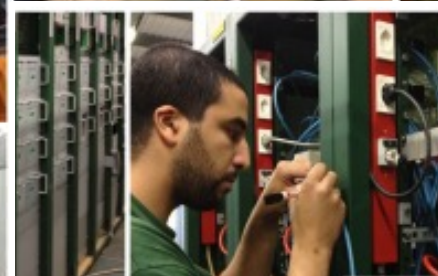
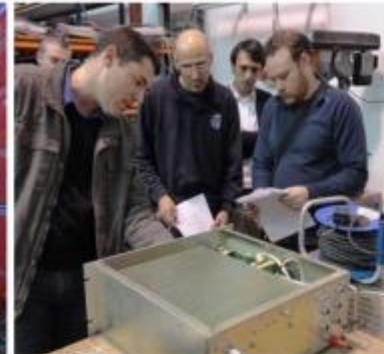



Conclusão

O LHC é precedido por uma cadeia de aceleradores de dimensões e energia crescentes

Como guiar e acelerar o feixe de partículas

O LHC necessita criogenia e vácuo

Gamas de pressão :

diferentes tipos de sensores e tipos de bombas são utilizadas segundo os níveis de pressão

O sistema de vácuo está dividido em sectores (sectorizado)

A arquitectura do sistema de controlo do vácuo do CERN tem 3 camadas (campo , controlo , supervisão)

O SCADA é o software que permite aos operadores interagirem com o processo e analisar o passado

Nem toda a história das medidas é arquivada :

Valores analógicos: filtros permitem arquivar apenas o essencial

Valores de estado: são todos arquivados