

Física com a experiência ATLAS

CERN, Escola de Professores em Língua Portuguesa
Setembro 2023

Ana Luísa Carvalho pelo grupo português de ATLAS

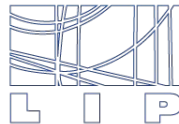

De que são feitas as coisas?

- Átomo \Rightarrow Núcleo \Rightarrow Protões \Rightarrow Quarks \Rightarrow ...?

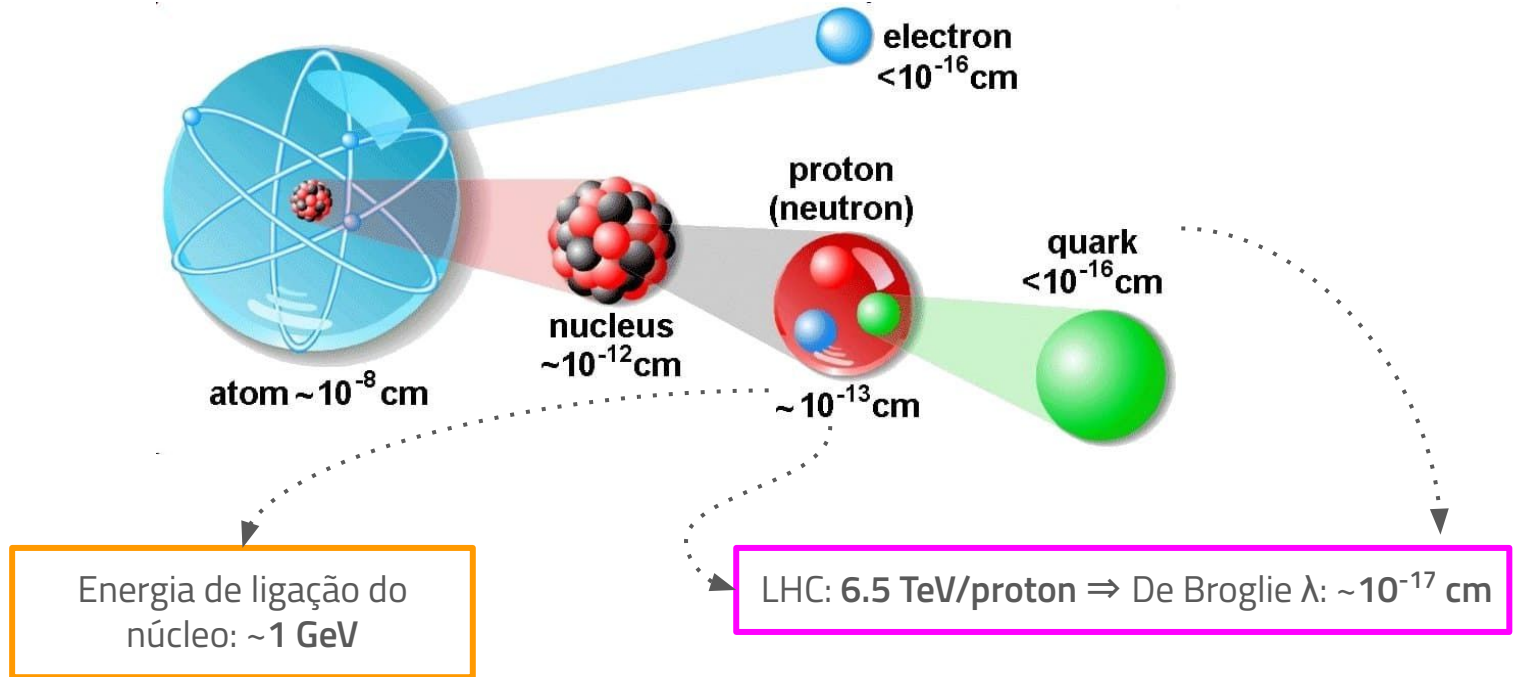

De que são feitas as coisas?

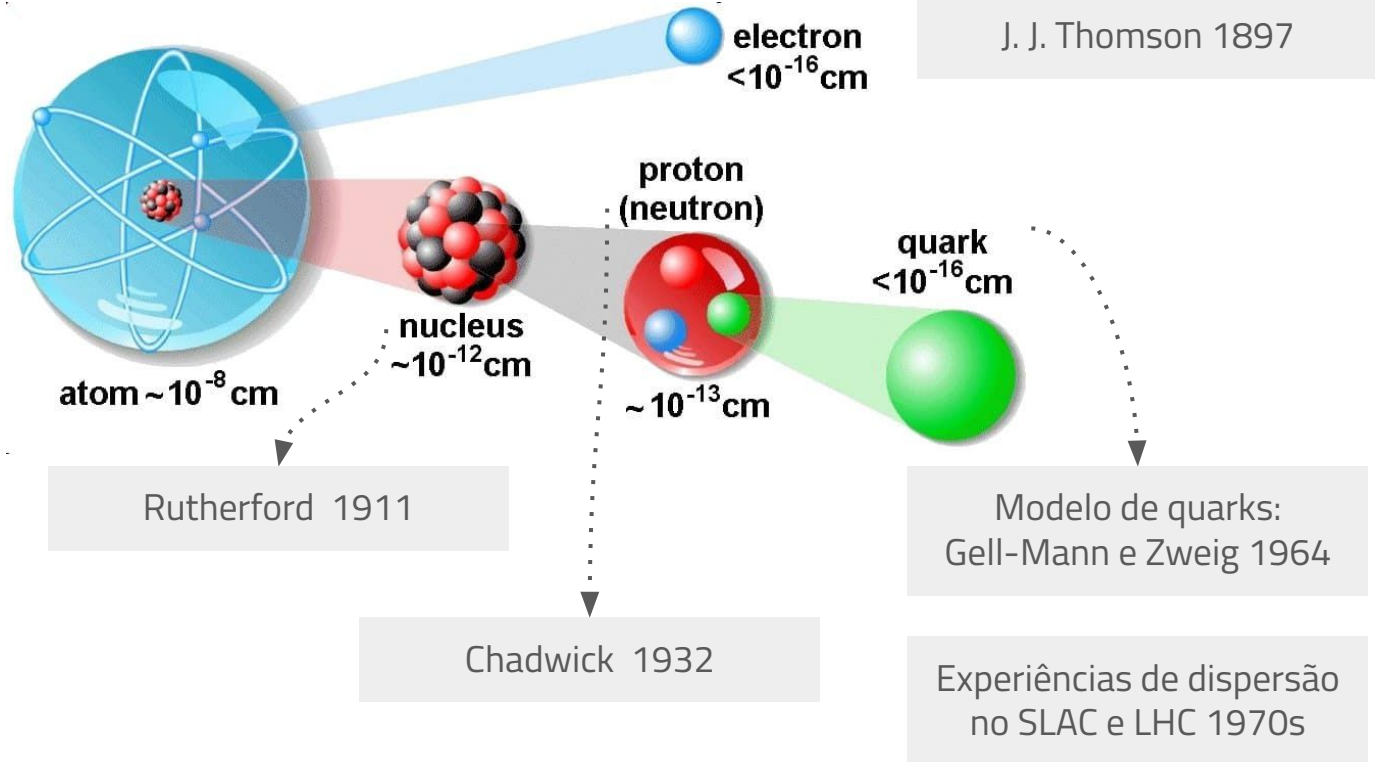

Modelo padrão da Física de Partículas

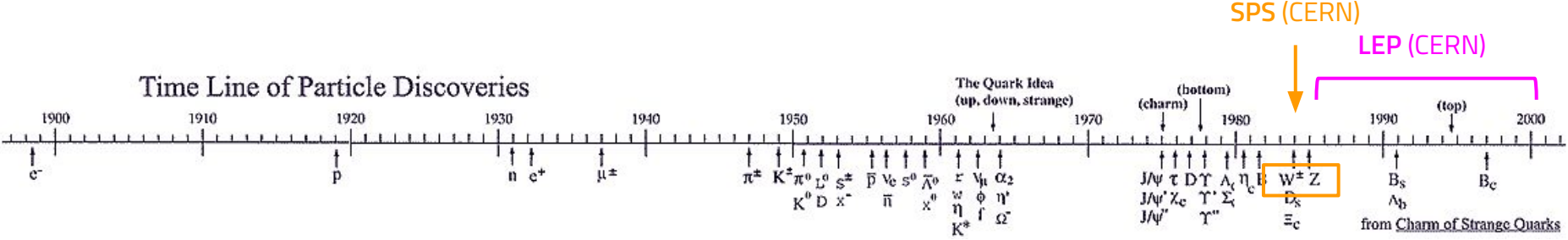

Modelo padrão da Física de Partículas

Time Line of Particle Discoveries

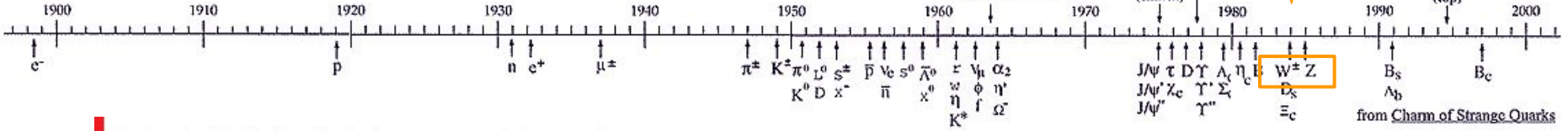

The Standard Model of particle physics
 Years from concept to discovery

■ Leptons
■ Bosons
■ Quarks
| Theorised/explained
| Discovered

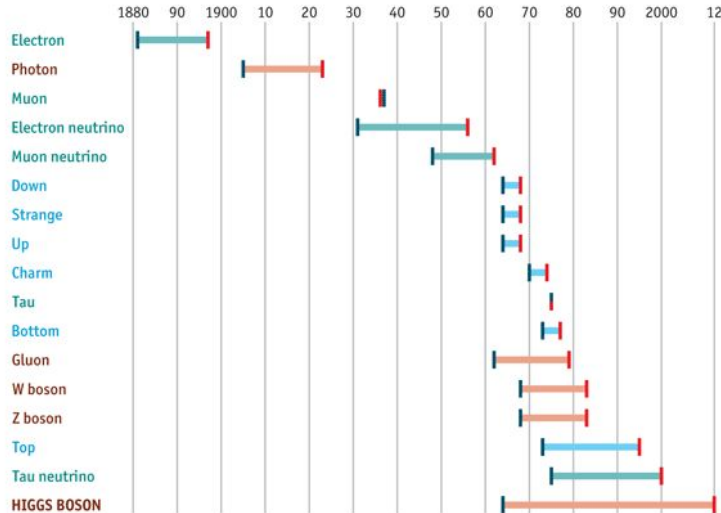

Source: *The Economist*

PARTICLE DISCOVERIES

The Large Hadron Collider discovered an elementary particle, the Higgs boson, in 2012. But it has also discovered 62 non-elementary particles, called hadrons, so far. These include tetraquarks and pentaquarks — particles made of four and five quarks, respectively.

● Tetraquark ● Pentaquark

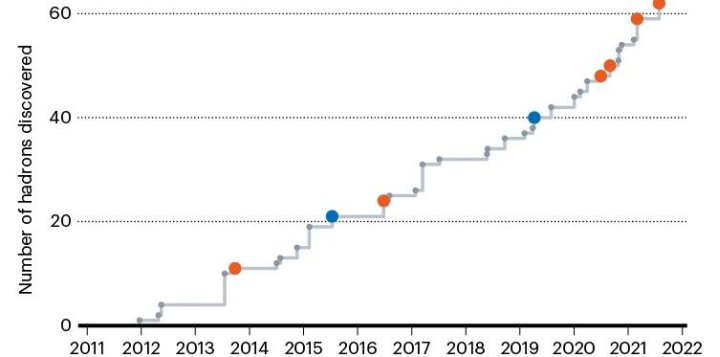

Modelo padrão da Física de Partículas

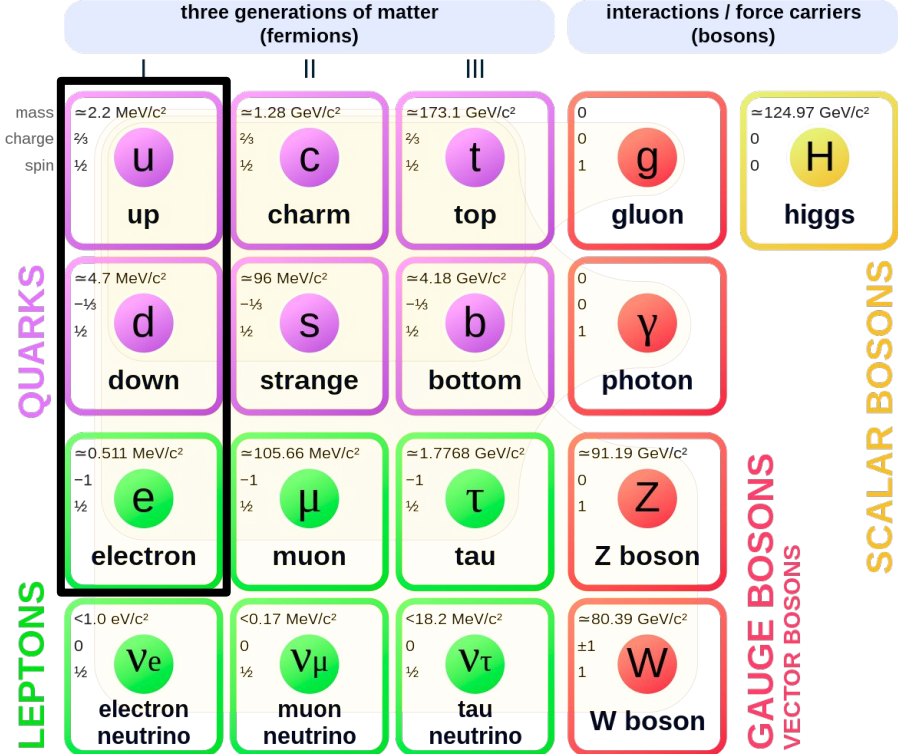

Modelo padrão da Física de Partículas

- Porquê três famílias?
- Massa dos neutrinos?
- Natureza da interação de Higgs?
- Papel da gravidade?

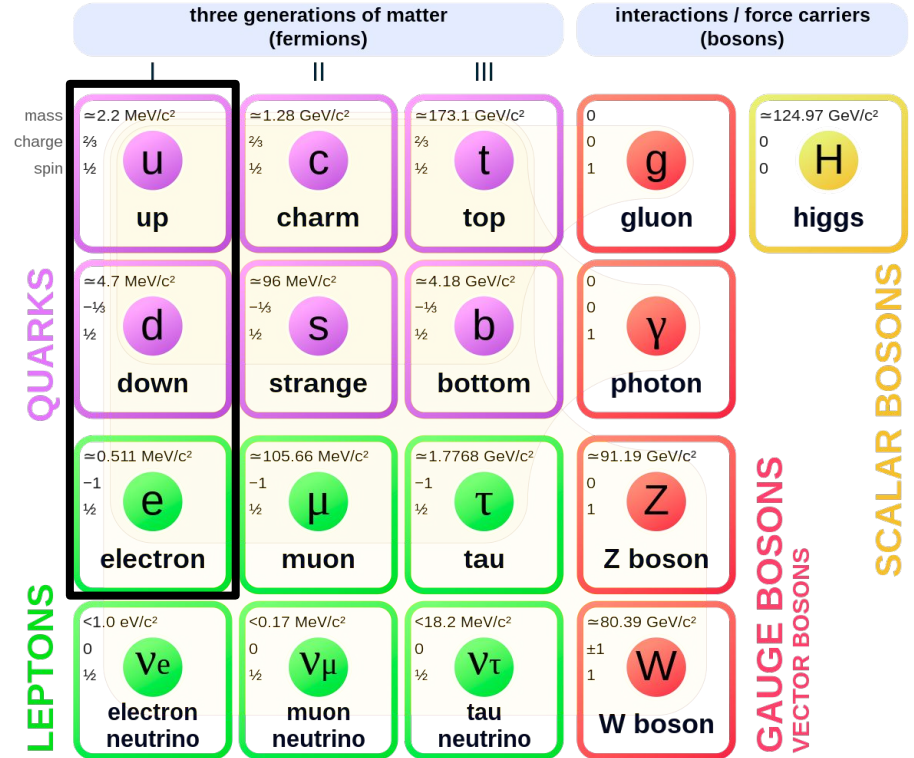

Teoria

$$\begin{aligned}
 \mathcal{L}_{SM} = & \underbrace{\frac{1}{4} W_{\mu\nu} \cdot W^{\mu\nu} - \frac{1}{4} B_{\mu\nu} B^{\mu\nu} - \frac{1}{4} G_{\mu\nu}^\alpha G_{\mu\nu}^\alpha}_{\text{kinetic energies and self-interactions of the gauge bosons}} \\
 & + \underbrace{\bar{L} \gamma^\mu \left(i \partial_\mu - \frac{1}{2} g \tau \cdot W_\mu - \frac{1}{2} g' Y B_\mu \right) L + \bar{R} \gamma^\mu \left(i \partial_\mu - \frac{1}{2} g' Y B_\mu \right) R}_{\text{kinetic energies and electroweak interactions of fermions}} \\
 & + \underbrace{\frac{1}{2} \left| \left(i \partial_\mu - \frac{1}{2} g \tau \cdot W_\mu - \frac{1}{2} g' Y B_\mu \right) \phi \right|^2 - V(\phi)}_{W^\pm, Z, \gamma \text{ and Higgs masses and couplings}} \\
 & + \underbrace{g'' (\bar{q} \gamma^\mu T_a q) G_\mu^\alpha}_{\text{interactions between quarks and gluons}} + \underbrace{\left(G_1 \bar{L} \phi R + G_2 \bar{L} \phi_c R + h.c. \right)}_{\text{fermion masses and couplings to Higgs}}
 \end{aligned}$$

Na prática

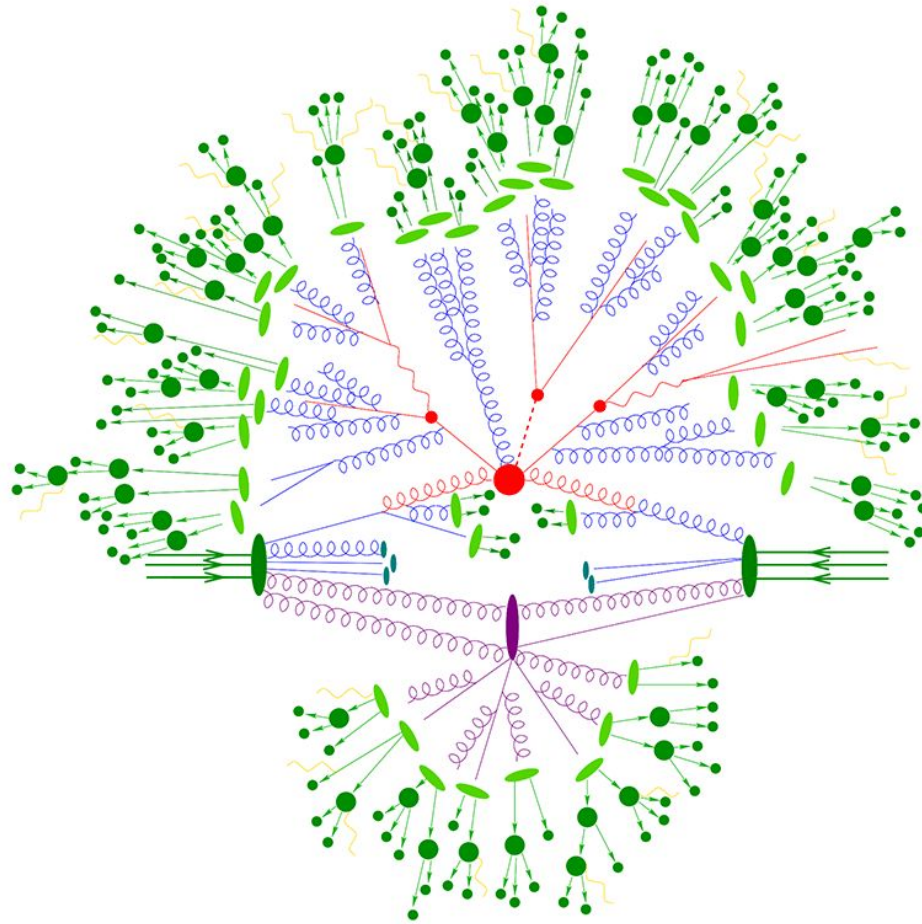

Simulações de Monte Carlo

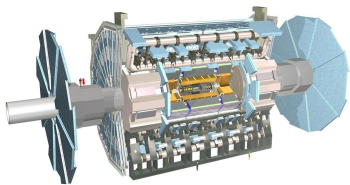

Dados

Trigger

Digitização

Reconstrução

"Hard scattering"

Showering e hadronização

Simulação (Geant4)

Digitização

Reconstrução

Análise

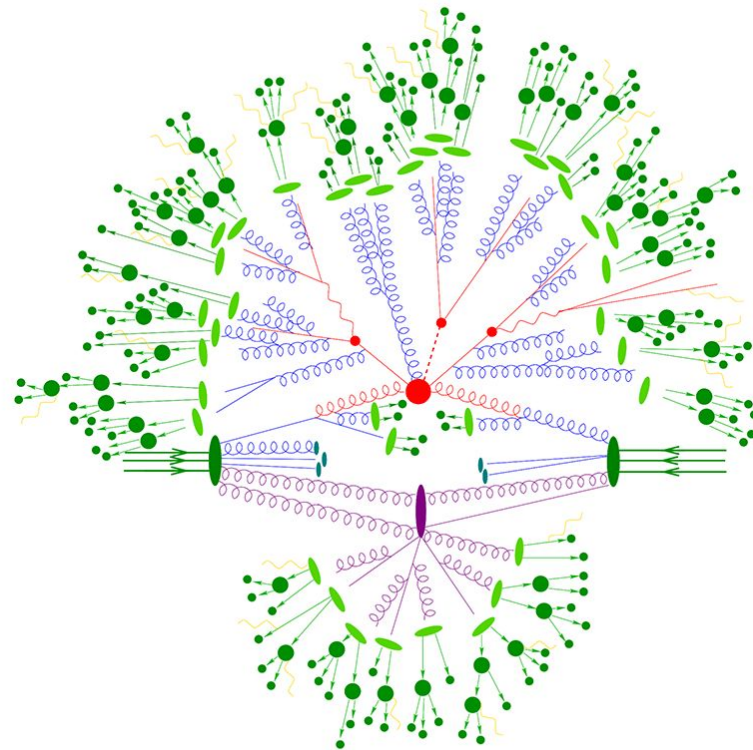

Large Hadron Collider

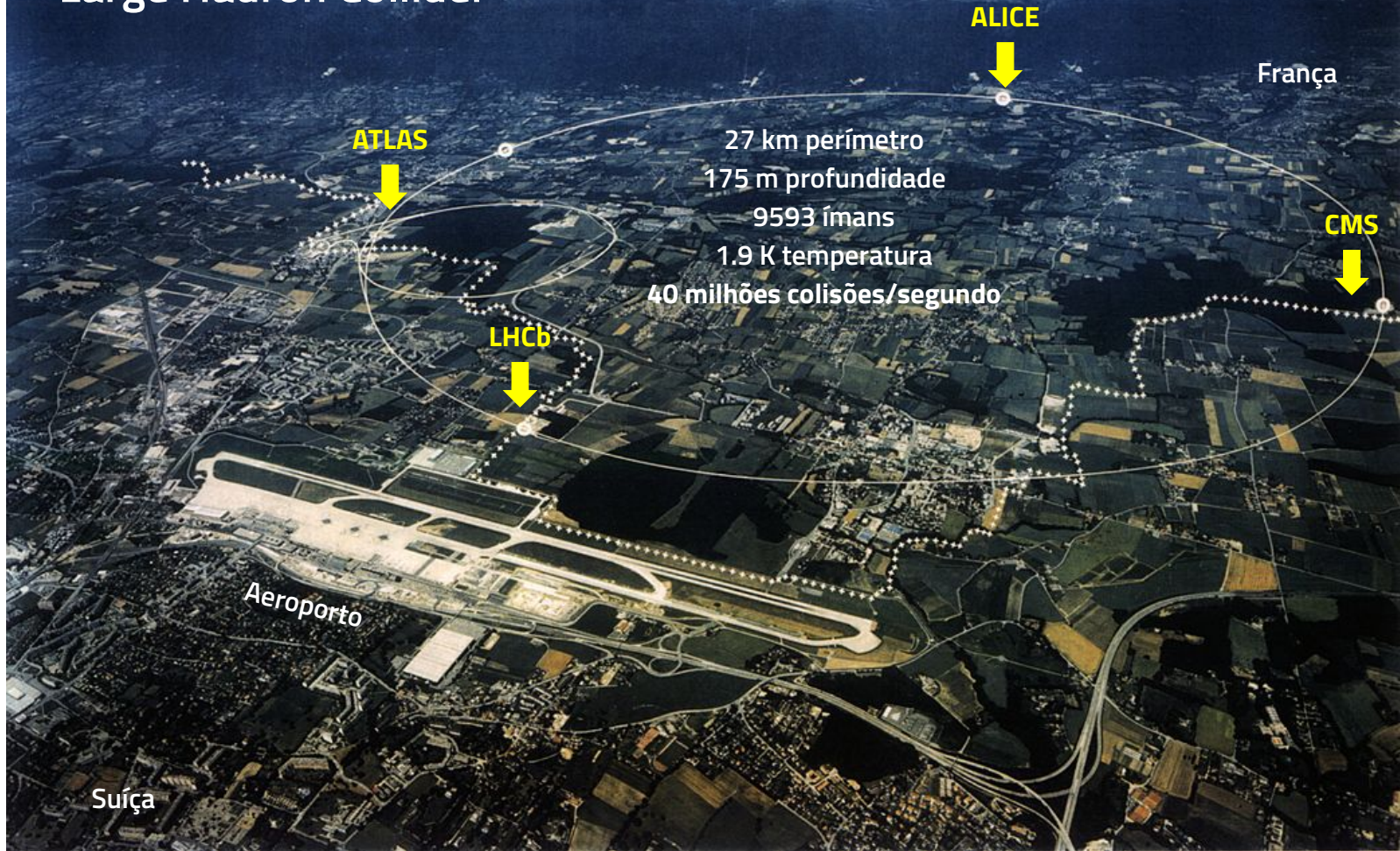

Large Hadron Collider

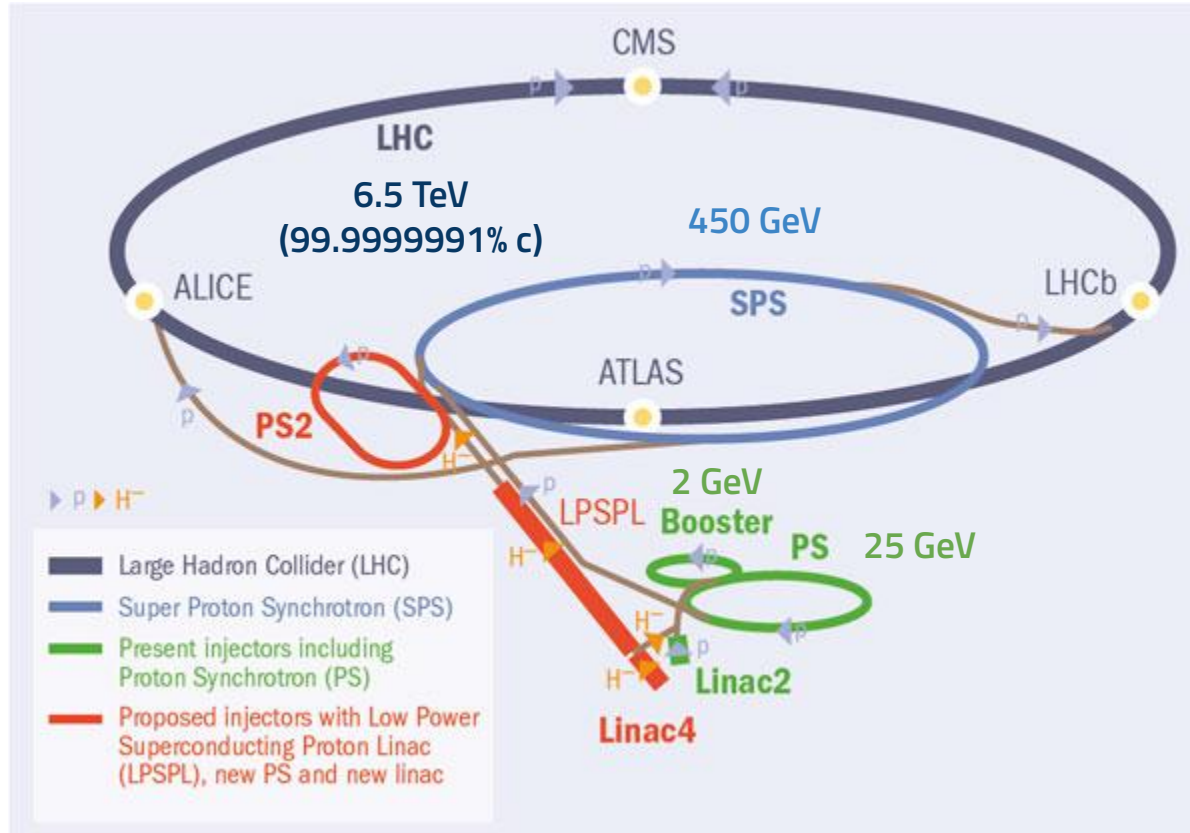

Os feixes de prótons têm estrutura

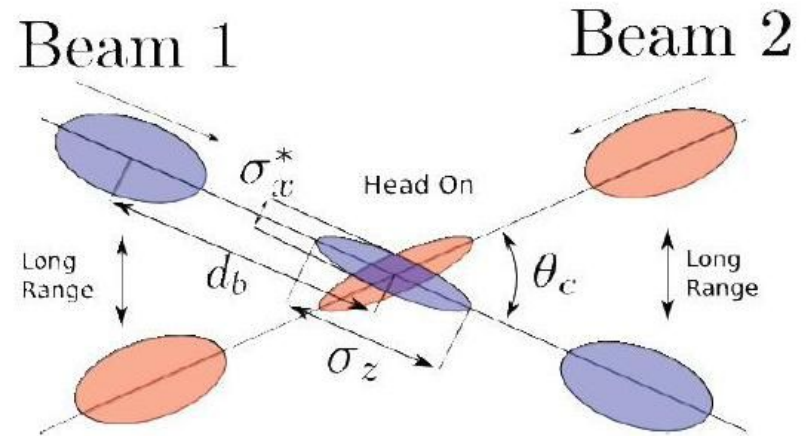
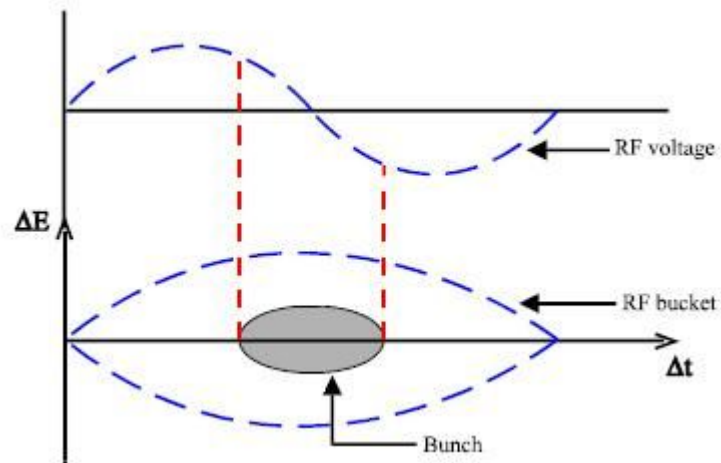

Pileup

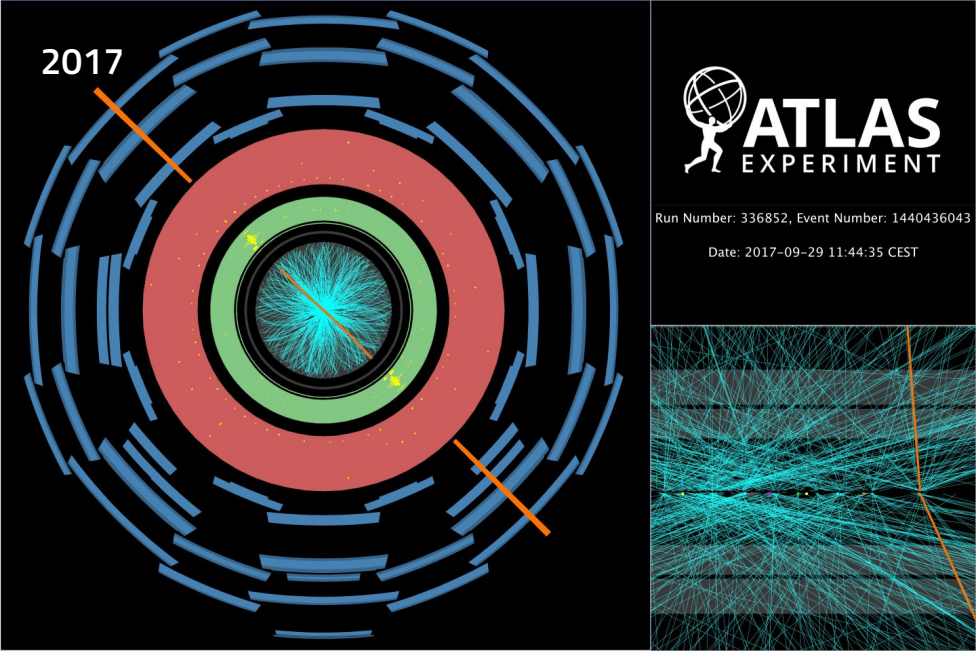
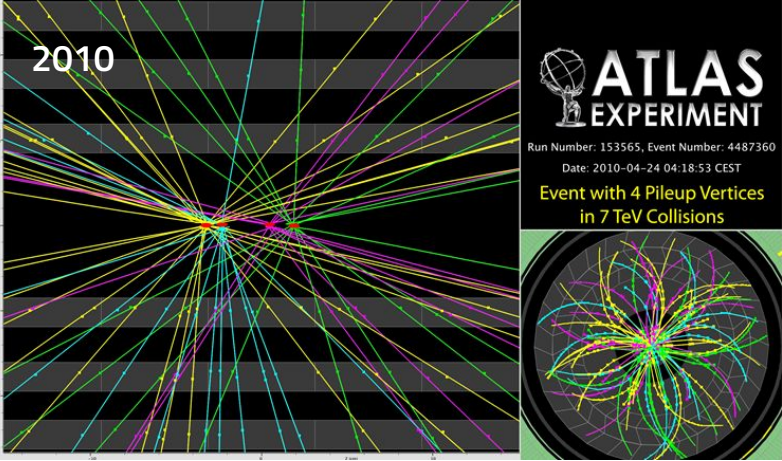

Porque é que complicamos a nossa vida?

Número de eventos = **Luminosidade [pb⁻¹]** x **Secção eficaz [pb]**

Depende de parâmetros dos feixes e da forma como eles se cruzam nos pontos de interação

$$L = \frac{N_b^2 n_b f_{\text{rev}} \gamma_r}{4\pi \epsilon_n \beta^*} F$$



$$L = n_b \frac{\langle \mu \rangle f_{\text{rev}}}{\sigma_{\text{inelastic}}}$$

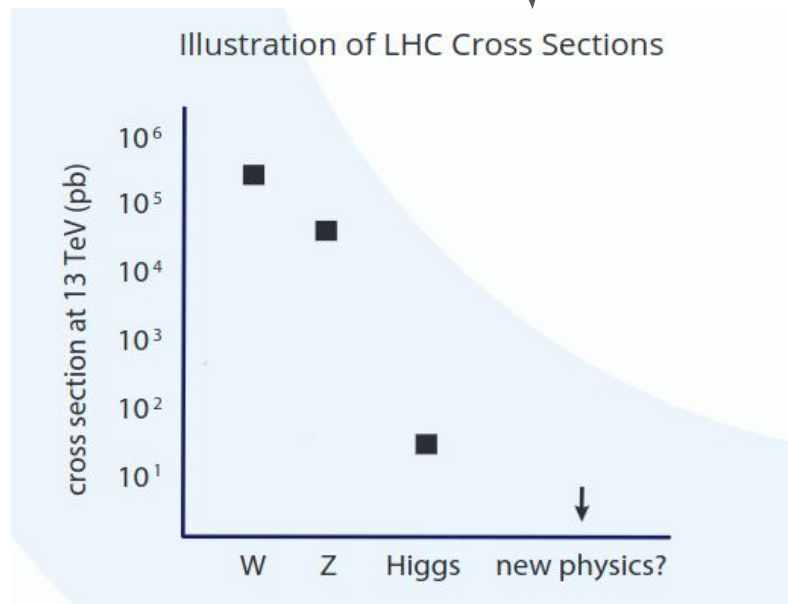

Experiência ATLAS

- Geometria cilíndrica: 44 m comprimento e 25 m diâmetro
- Múltiplos subdetetores organizados de forma concêntrica em torno do ponto de interação

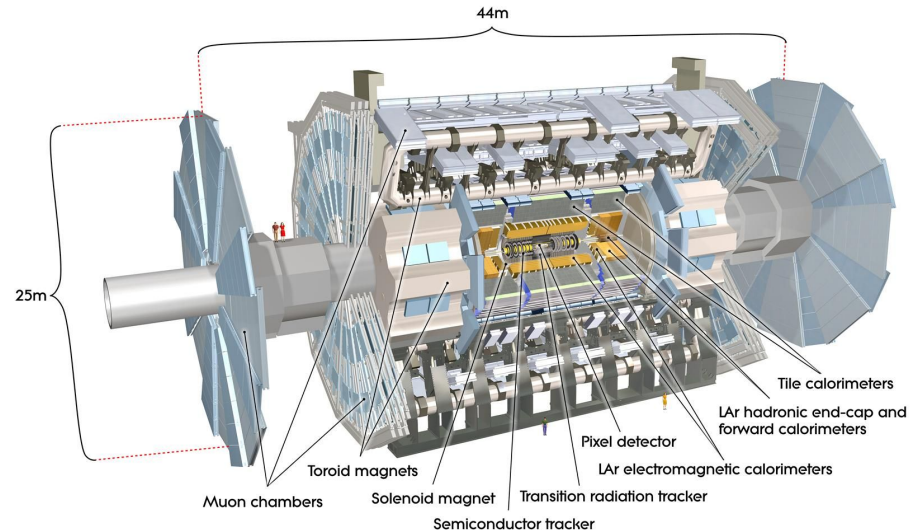
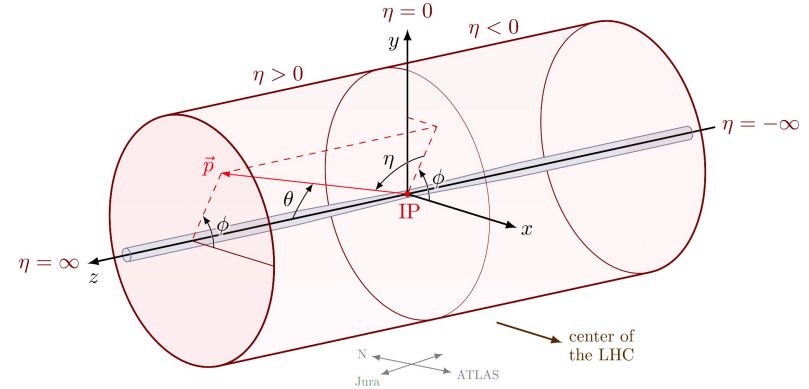
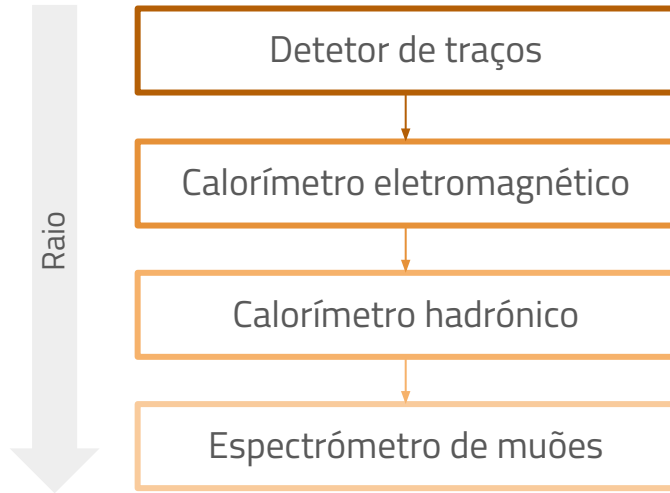

Calorímetro hadrónico de telhas

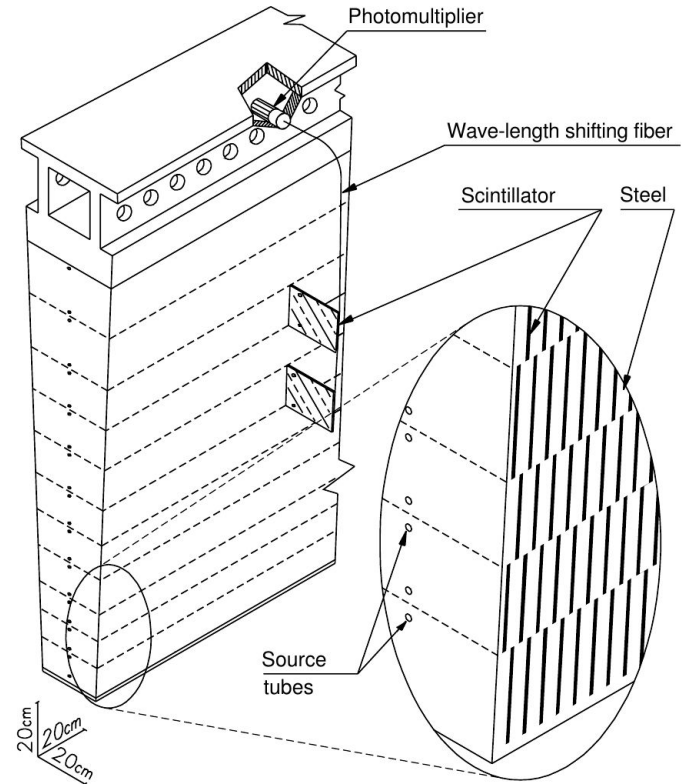

Reconstrução de objetos

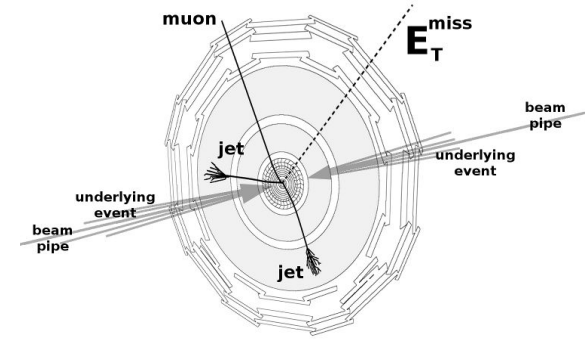
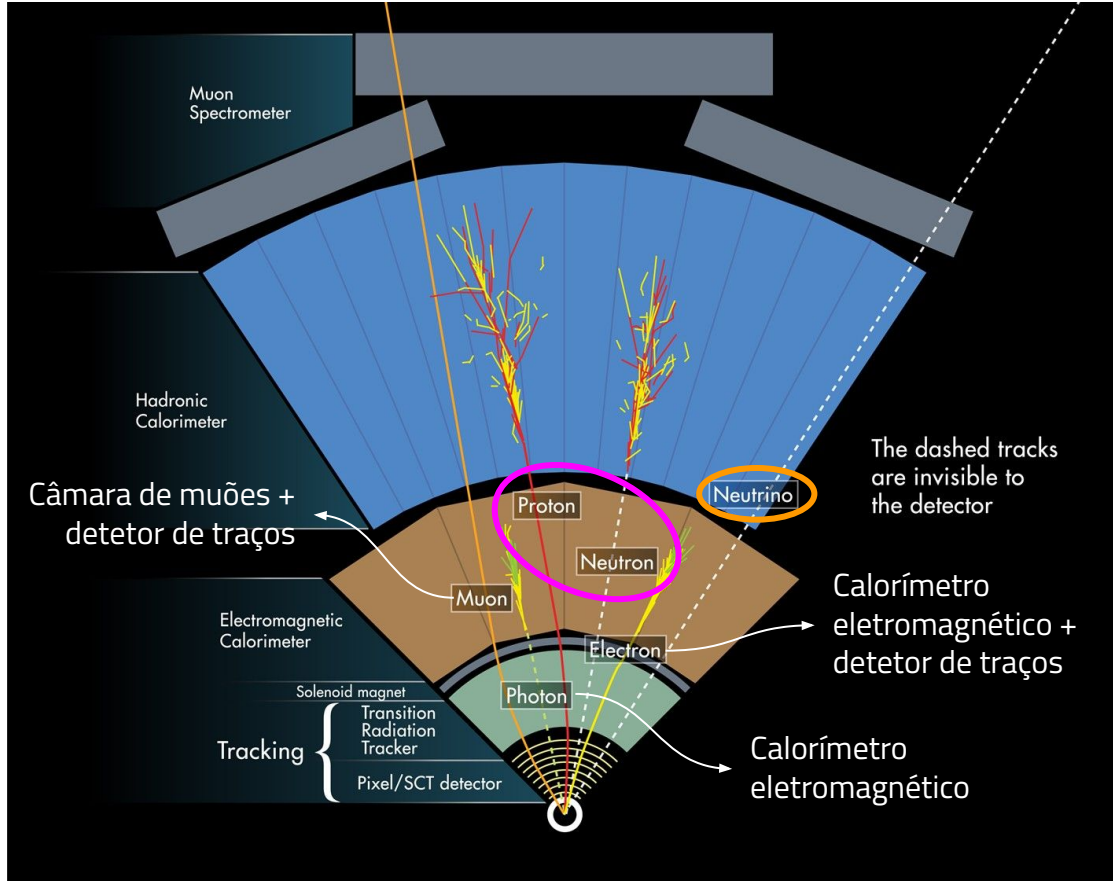

Neutrinos e outras partículas invisíveis:
energia transversa em falta

- Diferença entre a energia no plano transversa antes e depois da colisão

Hadrões: depósitos de energia nos calorímetros e/ou traços

Jatos

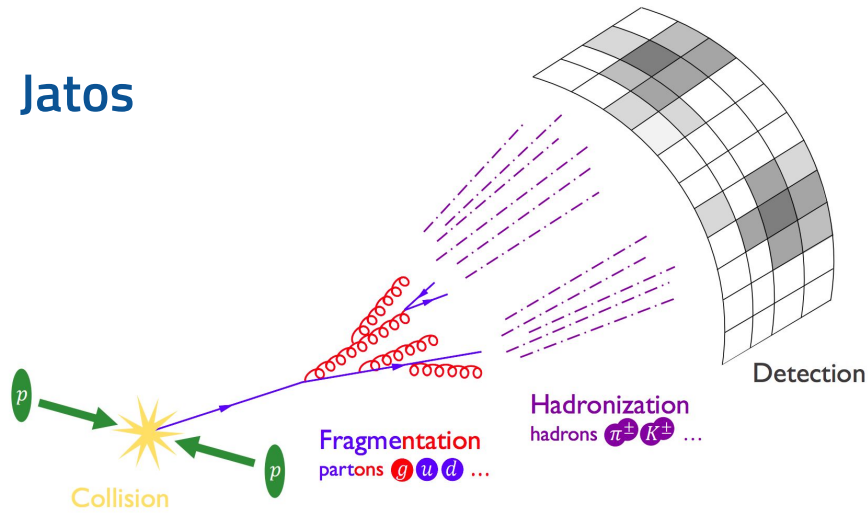

Spray colimado de hádrões iniciado por um quark ou glúão

Agrupar sequencialmente células dos calorímetros com energia superior a um determinado valor

- Jatos retêm informação acerca das propriedades do partão original: carga, momento, ...

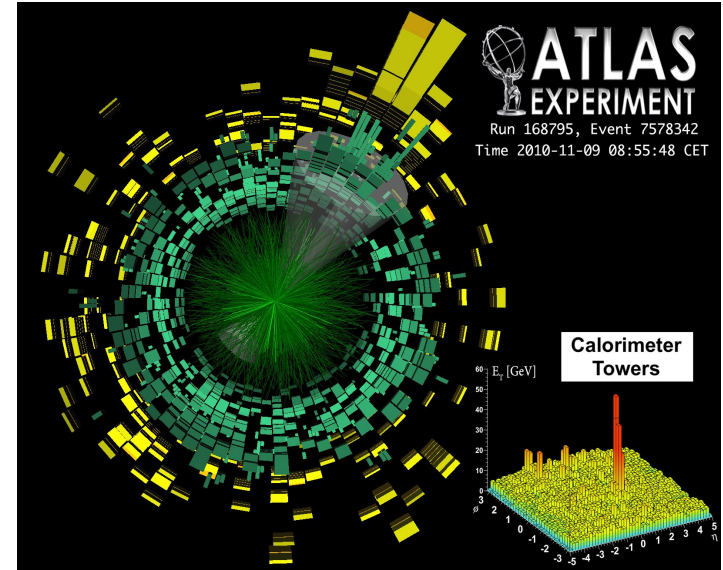

Jatos

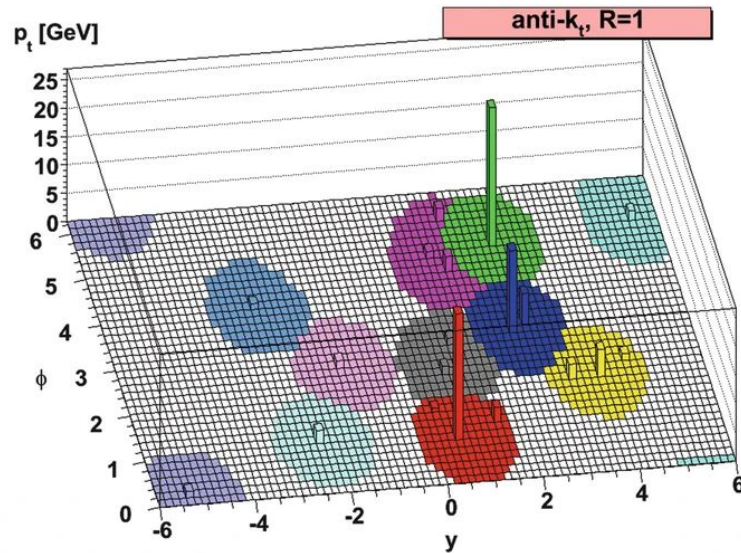
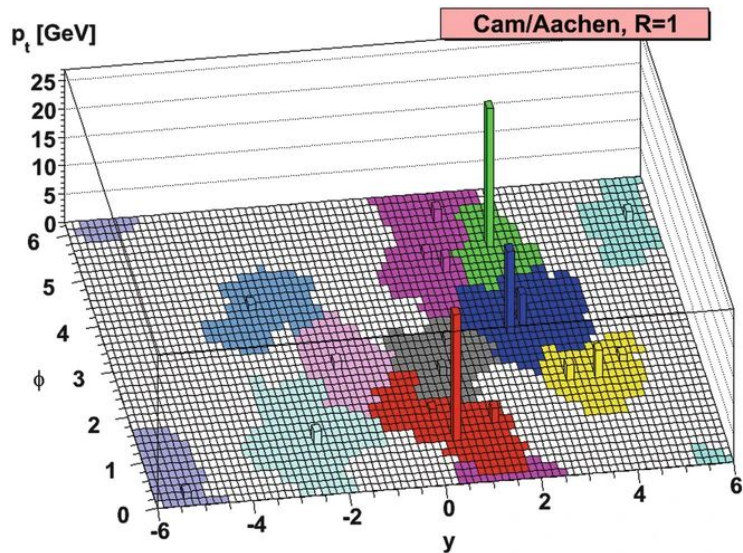

$$d_{ij} = \min \left(k_{ti}^{2p}, k_{tj}^{2p} \right) \frac{\Delta_{ij}^2}{R^2}$$

Jatos

Diferentes tipos de jatos de acordo com o partão que lhes deu origem:

- Jatos b \leftrightarrow Quarks b \leftrightarrow Hadrões B
- Jatos c \leftrightarrow Quarks c \leftrightarrow Hadrões C
- Jatos light \leftrightarrow Gluões ou quarks up/down



Como é que identificamos o tipo de partão que originou um jato?

Identificação de jatos b

- Tempo médio de vida de um hadrão B: ~ 1.5 ps \Rightarrow Viajam alguns mm dentro do detetor antes de decaírem \Rightarrow **Vértice secundário**
- Propriedades do vértice secundário (ex: distância ao vértice primário) e propriedades do jato e dos traços associados são combinadas num discriminante multivariável para distinguir jatos **b**, **c** e **light**

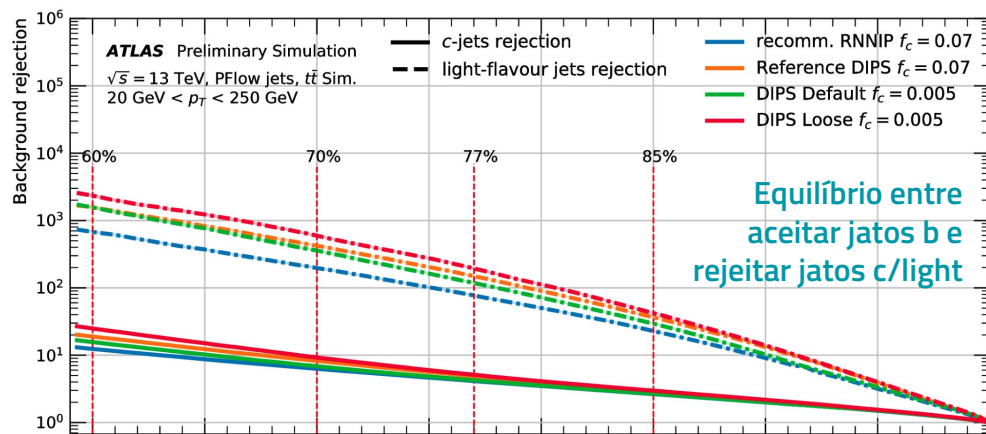
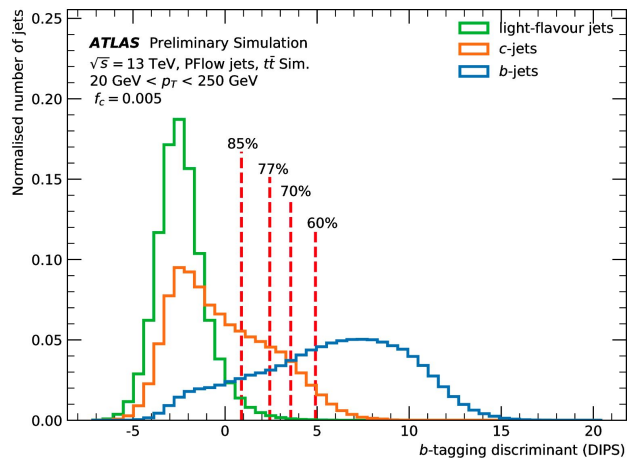
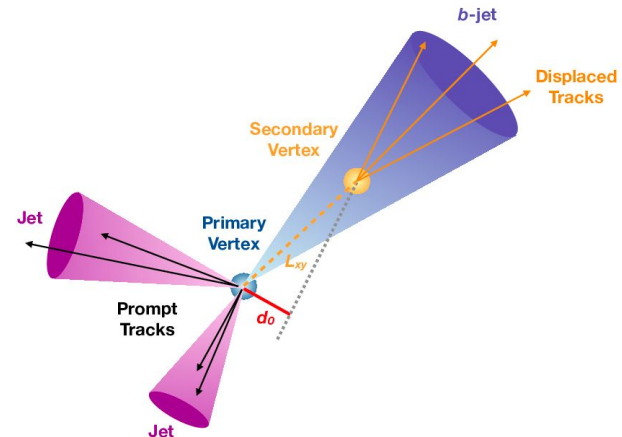

Trigger e aquisição de dados

40 milhões de colisões/segundo



Não é possível guardar todos os eventos



Sistema de trigger

Decidir em tempo real que eventos serão guardados

Dois níveis:

- Level-1 (L1): hardware customizado
 - 40 MHz → 100 kHz (~2 μ s)
- High-Level-Trigger (HLT): software
 - 100 kHz → 1 kHz (~100 ms)

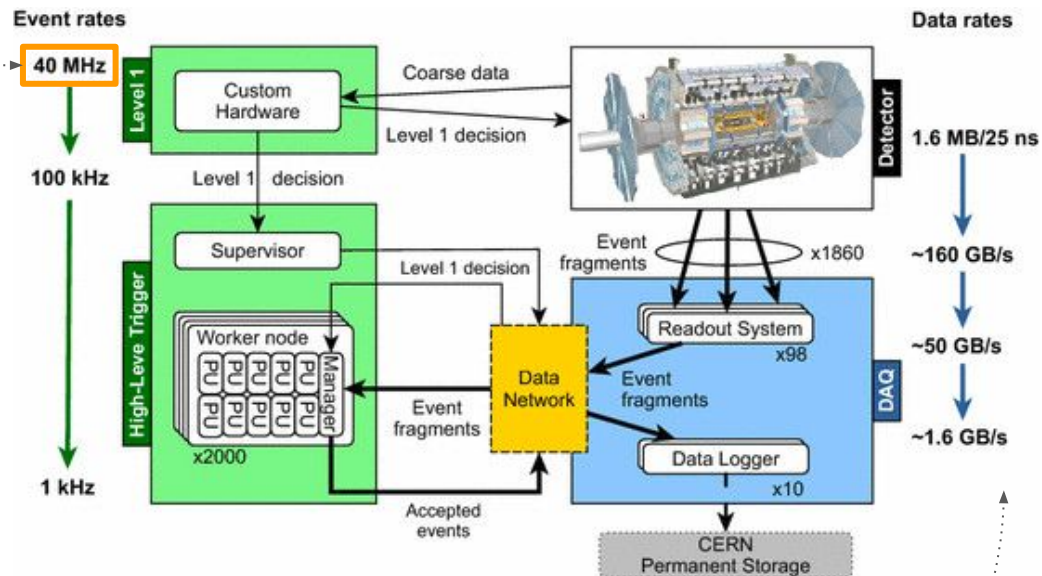

1.6 GB/s de eventos guardados para análise de dados

Descoberta do bóson de Higgs 2012

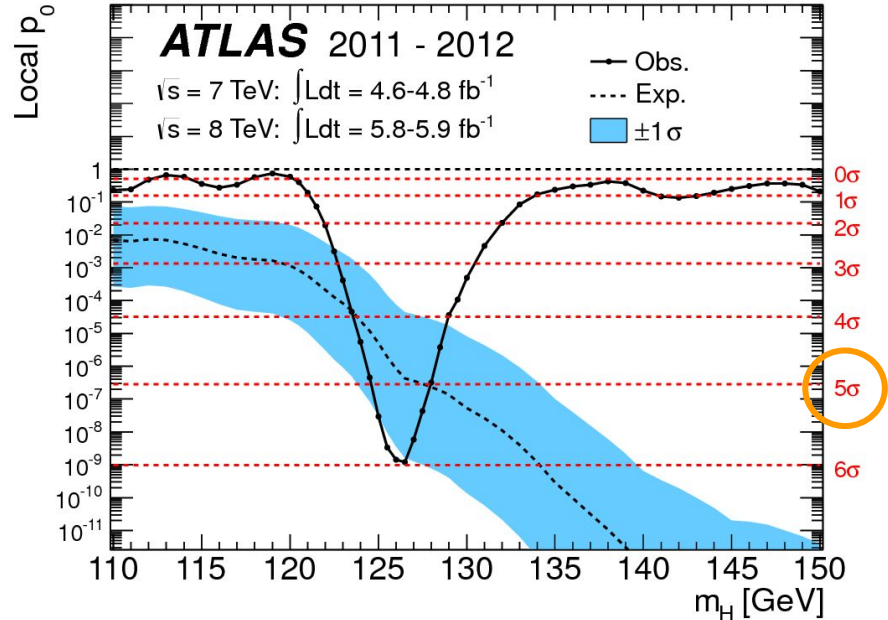
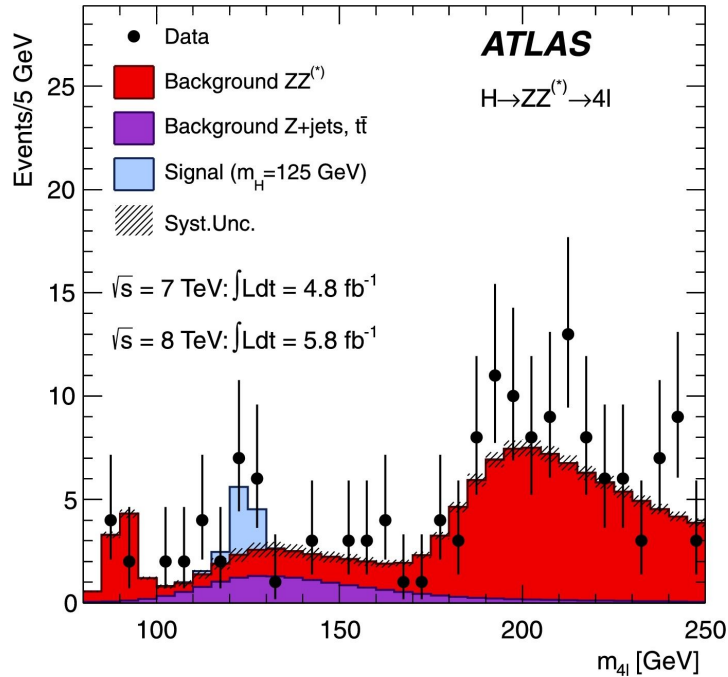

Probabilidade de o fundo (hipótese que estamos a tentar rejeitar) flutuar de modo a produzir o mesmo resultado é 1 em 3.5 milhões

Dez anos depois...

Modos de produção

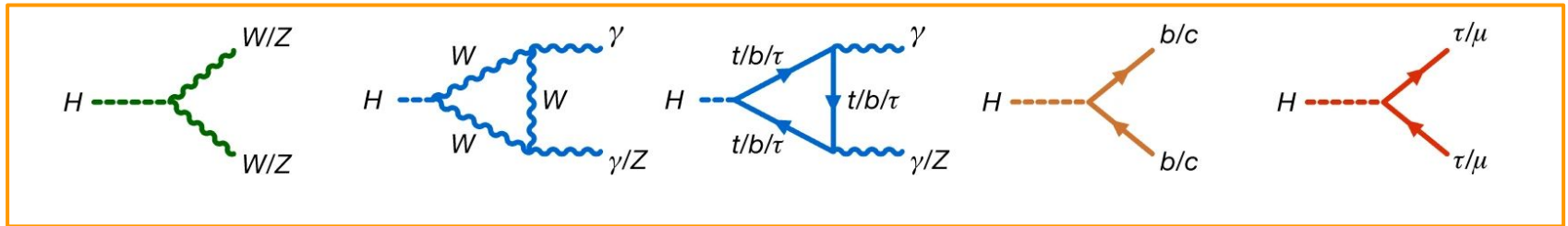
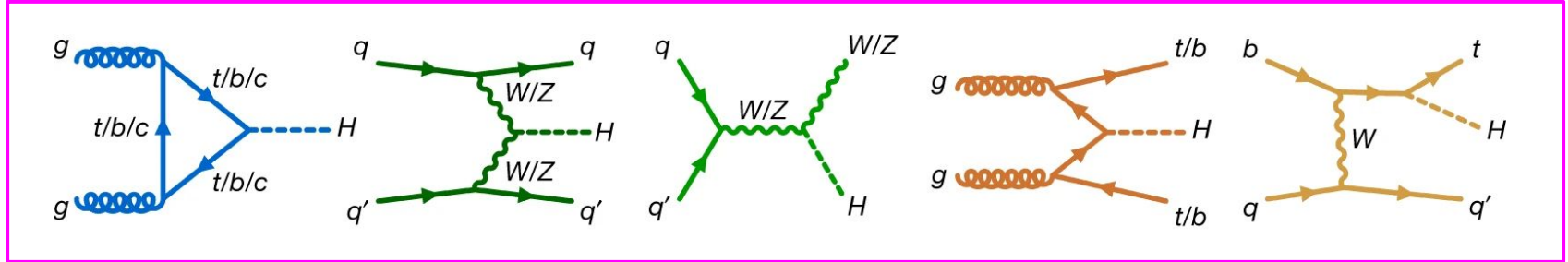

Canais de decaimento

10 anos depois...

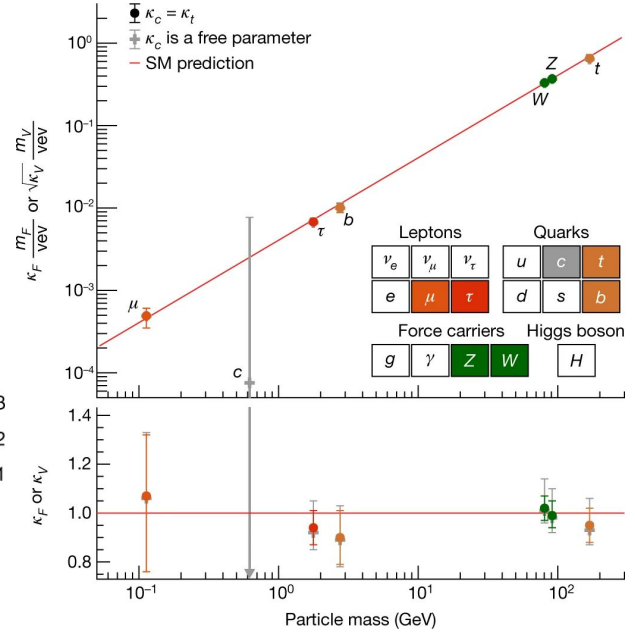
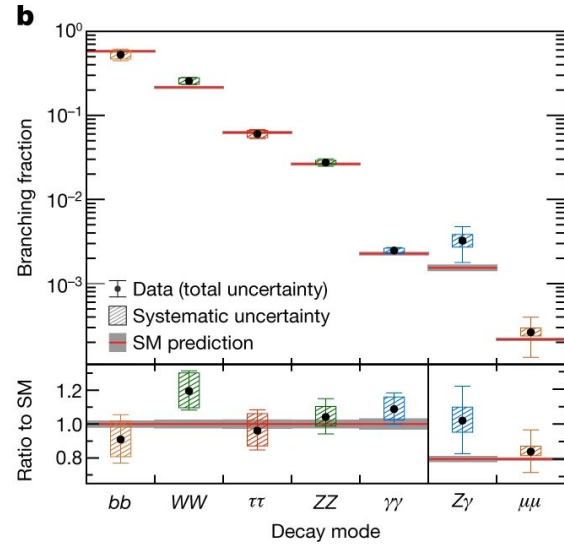
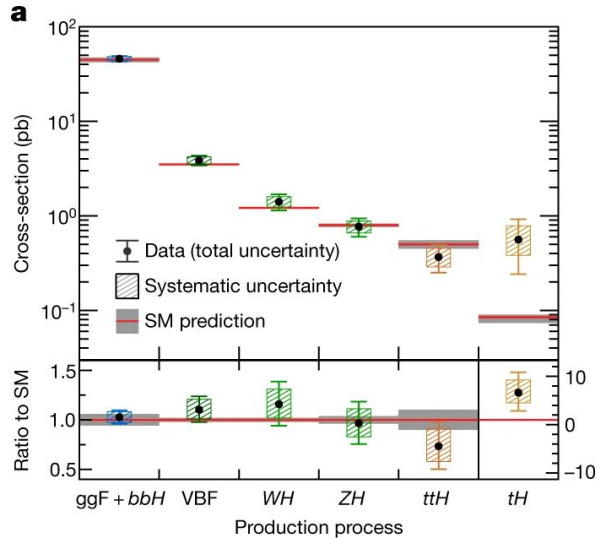

Questões em aberto

- Natureza da matéria escura?
 - Estudos cosmológicos do fundo de ondas microondas que permeiam o nosso Universo indicam que este tipo de matéria existe e em maior quantidade do que o esperado
- Porque é que existe muito mais matéria do que anti-matéria?
 - No modelo padrão apenas as interações fracas distinguem entre partículas e anti-partículas
 - Não é suficiente para explicar a assimetria entre matéria e anti-matéria
- Massa dos neutrinos?

Como tentamos responder a estas questões?



Colaborações internacionais





Portuguese ATLAS Team

National group:

LIP (Lisbon, Coimbra, Minho), FCUL, FCTUC, U. Minho, CFNUL
CEFITEC/UNL, INESC, CFMC, AdI engineers training program



Contribuições do grupo português de ATLAS

- Calorímetro hadrónico de telhas: construção, calibração e sistema de controlo
- Computação distribuída
- Trigger de jatos
- Roman pots e detetores forward
- Upgrade
 - Sistema de distribuição de alta voltagem do calorímetro de telhas
 - High Granularity Timing Detector
- Descoberta e propriedades do bóson de Higgs: $H \rightarrow WW^*$, $H \rightarrow bb$, ttH
- Medidas das propriedades do quark top
- Física em colisões de iões pesados
- Buscas por nova física: vector-like quarks, Flavor Changing Neutral Currents, matéria escura



LIP-CMS team in 2022

Contribuições do grupo português de CMS

- Roman pots e detetores forward
- Calorímetro eletromagnético: trigger e aquisição de dados
- Computação
- Upgrade:
 - Detetores forward
 - Detetor de tempo
 - Calorímetros hadrónico e eletromagnético

- Descoberta do bóson de Higgs e propriedades: $H \rightarrow \gamma\gamma$
- Decaimentos raros de hádrões B: $B_s \rightarrow \mu\mu$
- Propriedades do quark top: secção eficaz, massa, ...
- Buscas por nova física: bósons de Higgs carregados, supersimetria,

Participação brasileira em ATLAS

- Level-1 trigger: hardware
- Calorímetro de telhas: hardware
- Estudos de desempenho do detetor
- Sistemas de controlo do detetor
- High-level trigger: estudos de otimização de software e performance

Como desenhar uma análise

- Usando um exemplo que me é familiar de uma medida de precisão das propriedades do bóson de Higgs

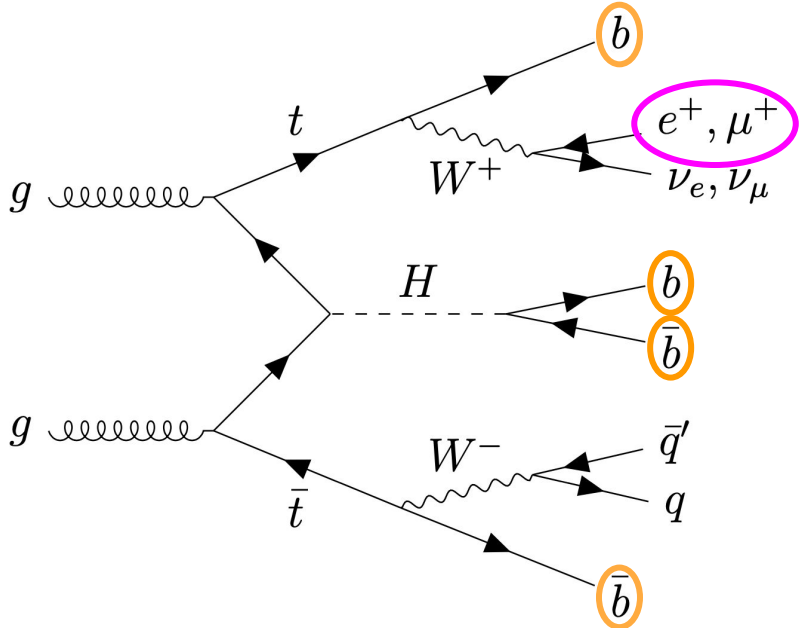
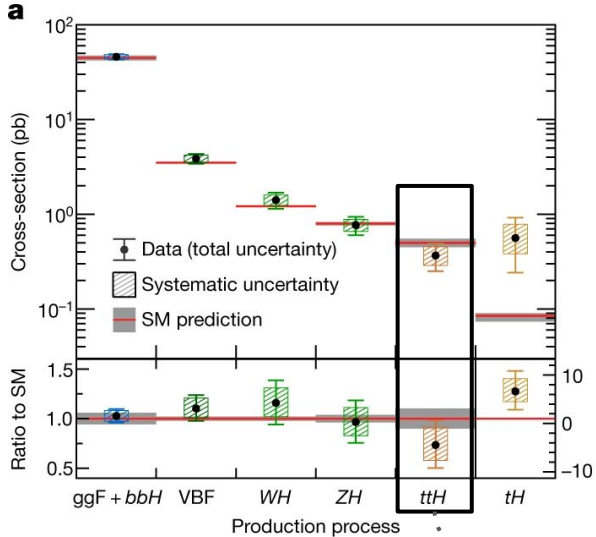

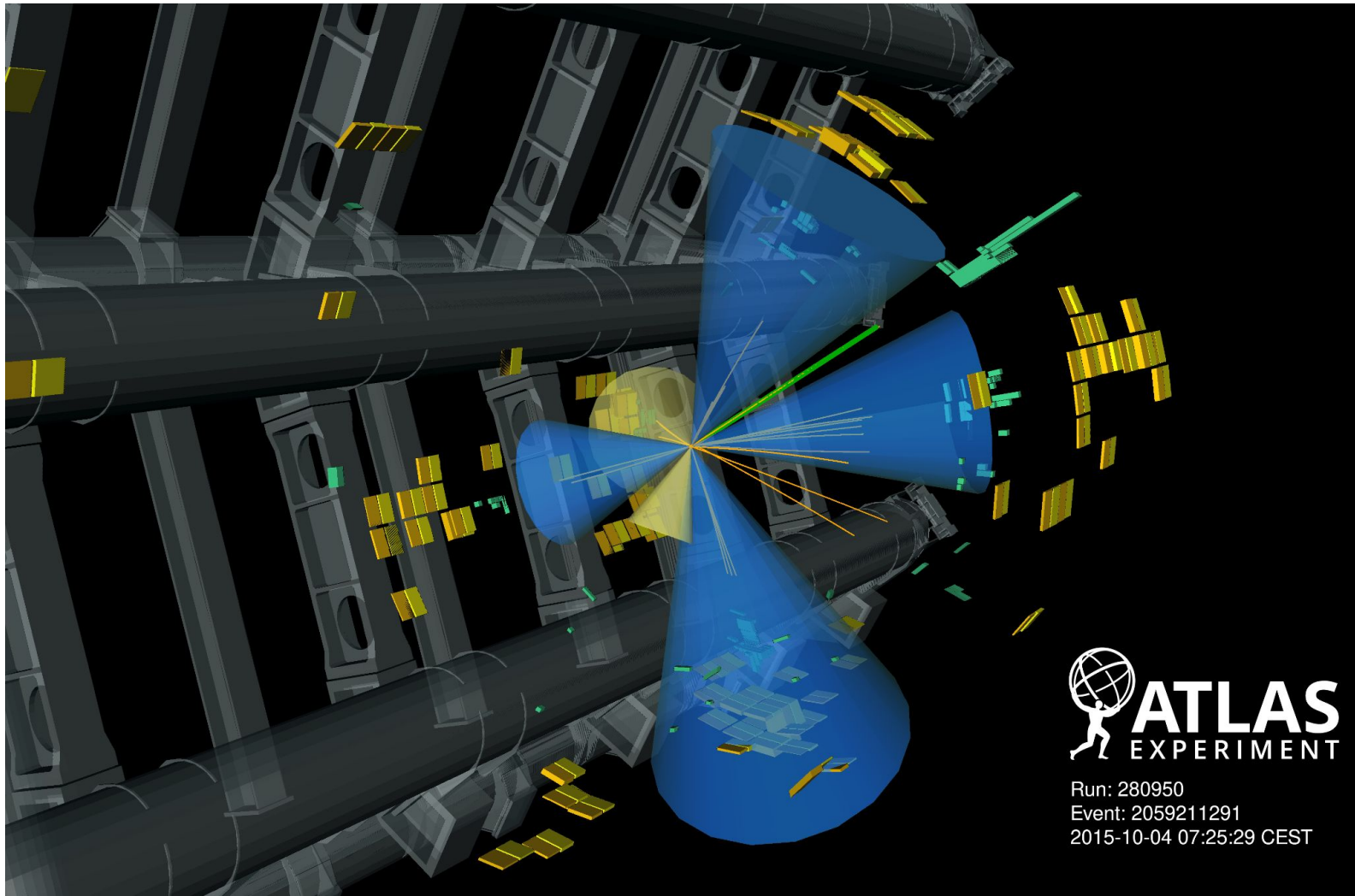

 **ATLAS**
EXPERIMENT

Run: 280950
Event: 2059211291
2015-10-04 07:25:29 CEST

O desafio

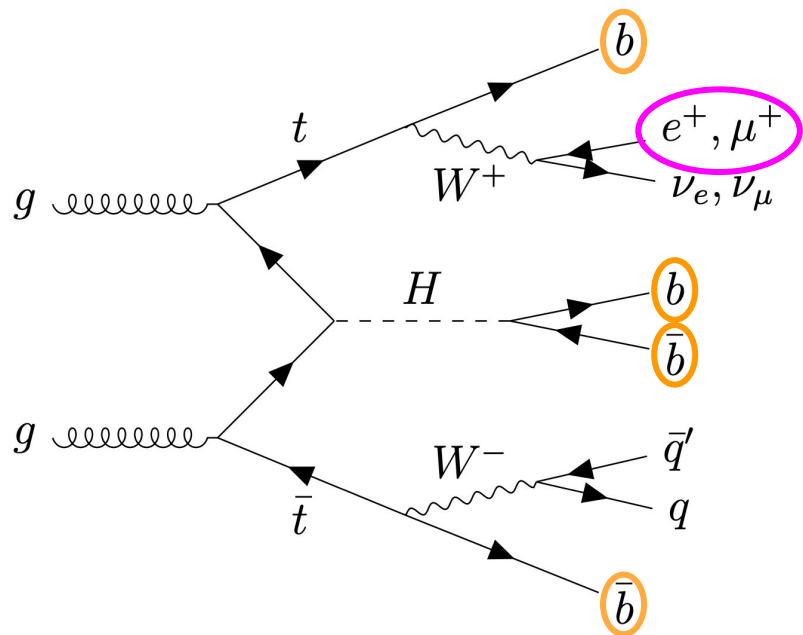

Sinal

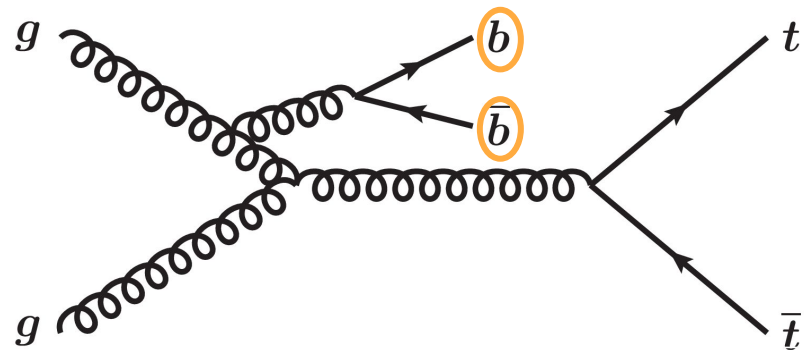

Fundo

O desafio

Standard Model Total Production Cross Section Measurements

Status: February 2022

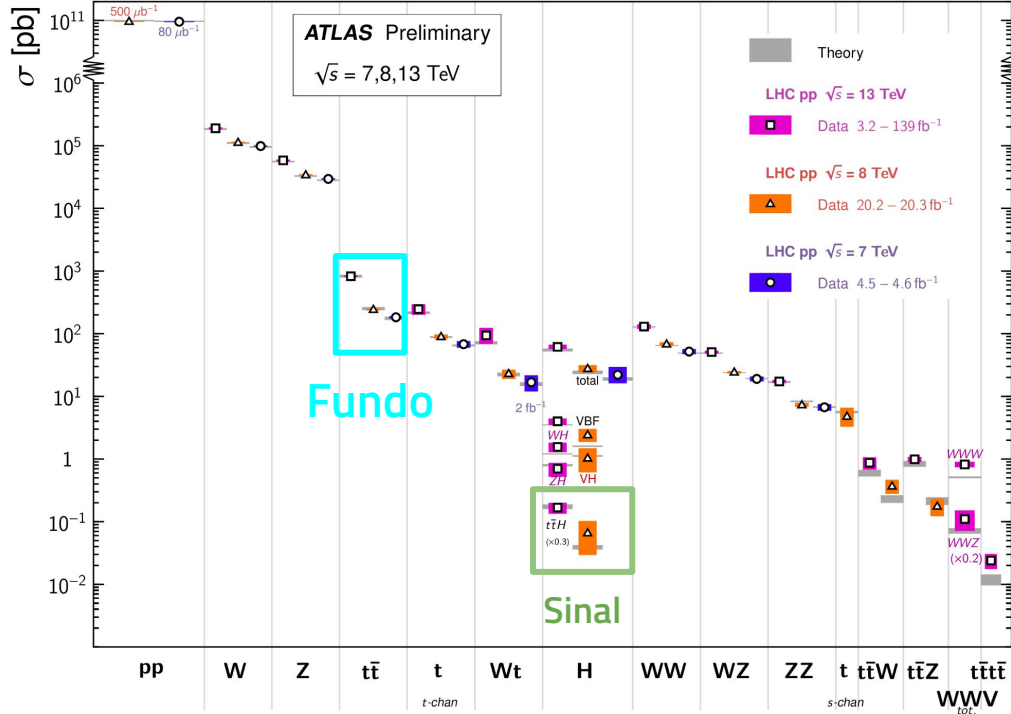

- Fundo dominante: produção de pares de quark top + jatos
 - $t\bar{t}b\bar{b} \Rightarrow$ Irredutível: muito difícil separar do sinal
 - Secção eficaz várias ordens de grandeza superior à do sinal
 - Modelos de MC não descrevem perfeitamente os dados



Secção eficaz do fundo $t\bar{t}+\geq 1\text{b}$ medida diretamente em dados nas regiões da análise

Variáveis que permitam distinguir sinal de fundos

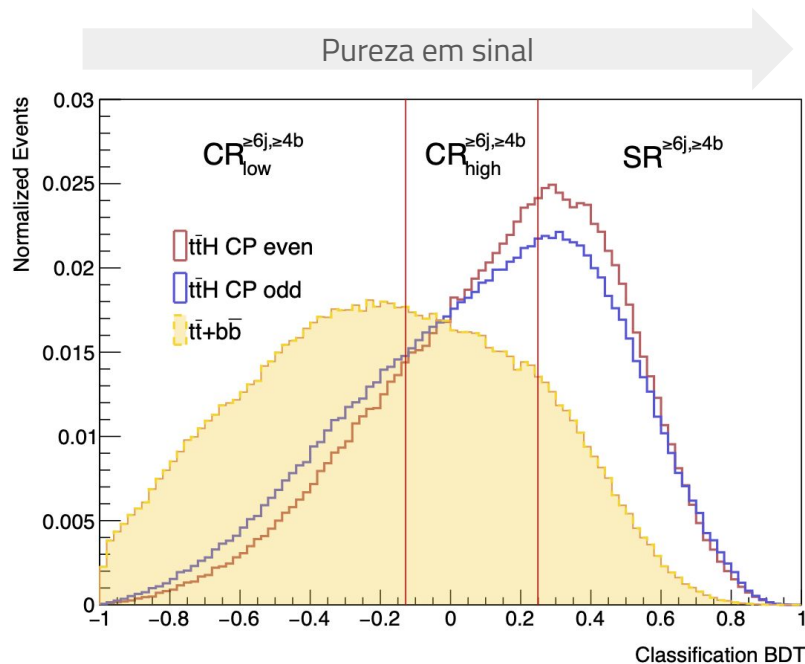
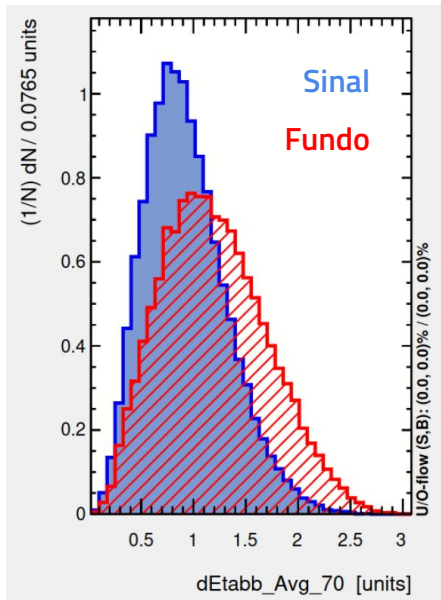

Média da diferença em pseudorapidez (η) entre os pares de quarks b

Muitas regiões de análise

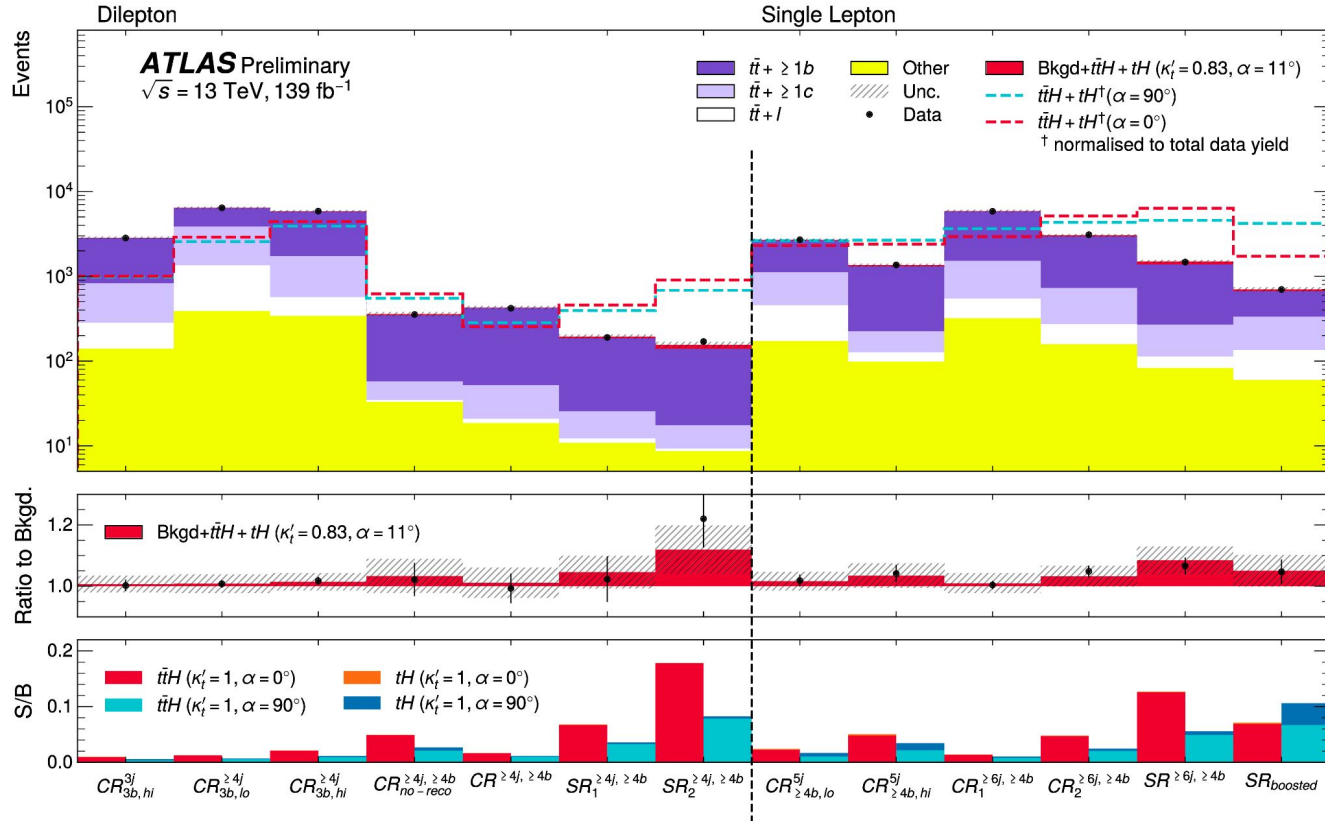

Como medimos?

Comparar um modelo (com pelo menos um parâmetro livre) com dados experimentais de modo a determinar o valor do parâmetro que melhor descreve os dados

$$\mathcal{L} = \prod_{i \in \text{bins}} \mathcal{P}(n_i | \mu \cdot S_i + B_i)$$

O nosso modelo: rácio de funções de likelihood

$$q_\alpha = \frac{\mathcal{L}(\alpha)}{\mathcal{L}(\hat{\alpha})}$$

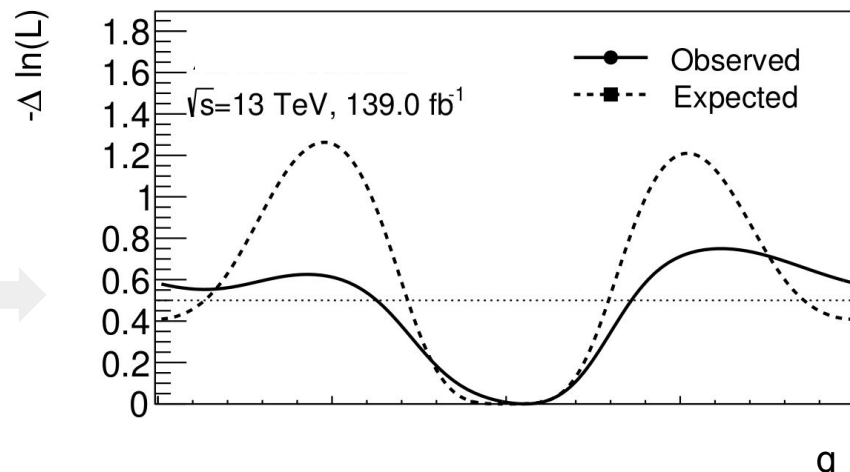
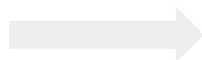

Mínimo da função de likelihood para um valor de α fixo

Mínimo absoluto da função de likelihood

Incertezas sistemáticas

Estimativa da nossa incerteza em relação a determinado parâmetro da análise

Exemplo

- Vários geradores de MC disponíveis para simular o mesmo processo físico \Rightarrow Resultados diferentes

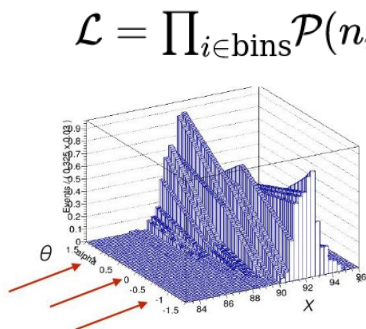
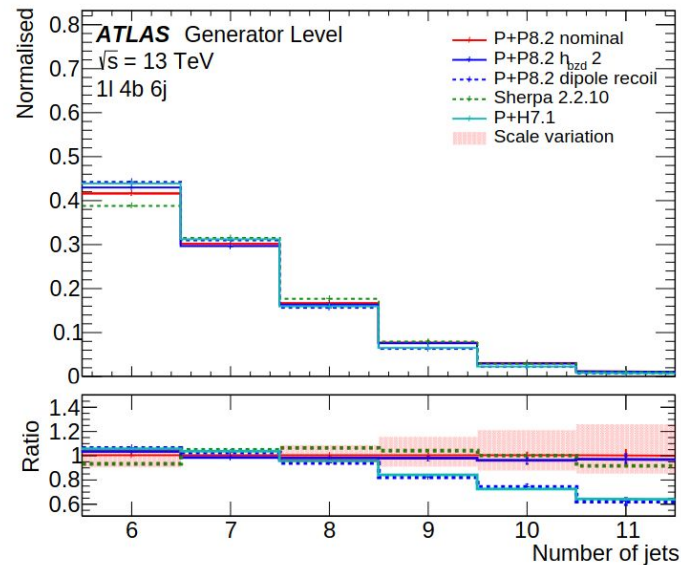

$$\mathcal{L} = \prod_{i \in \text{bins}} \mathcal{P}(n_i | \mu \cdot S_i(\theta) + B_i(\theta)) \times \prod_{j \in \text{sys}} \mathcal{G}(\theta)$$

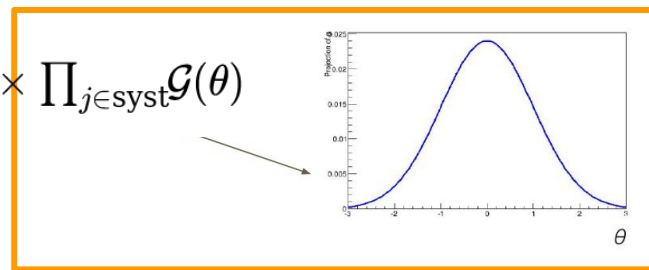

Medida/estimativa secundária

Buscas por nova física

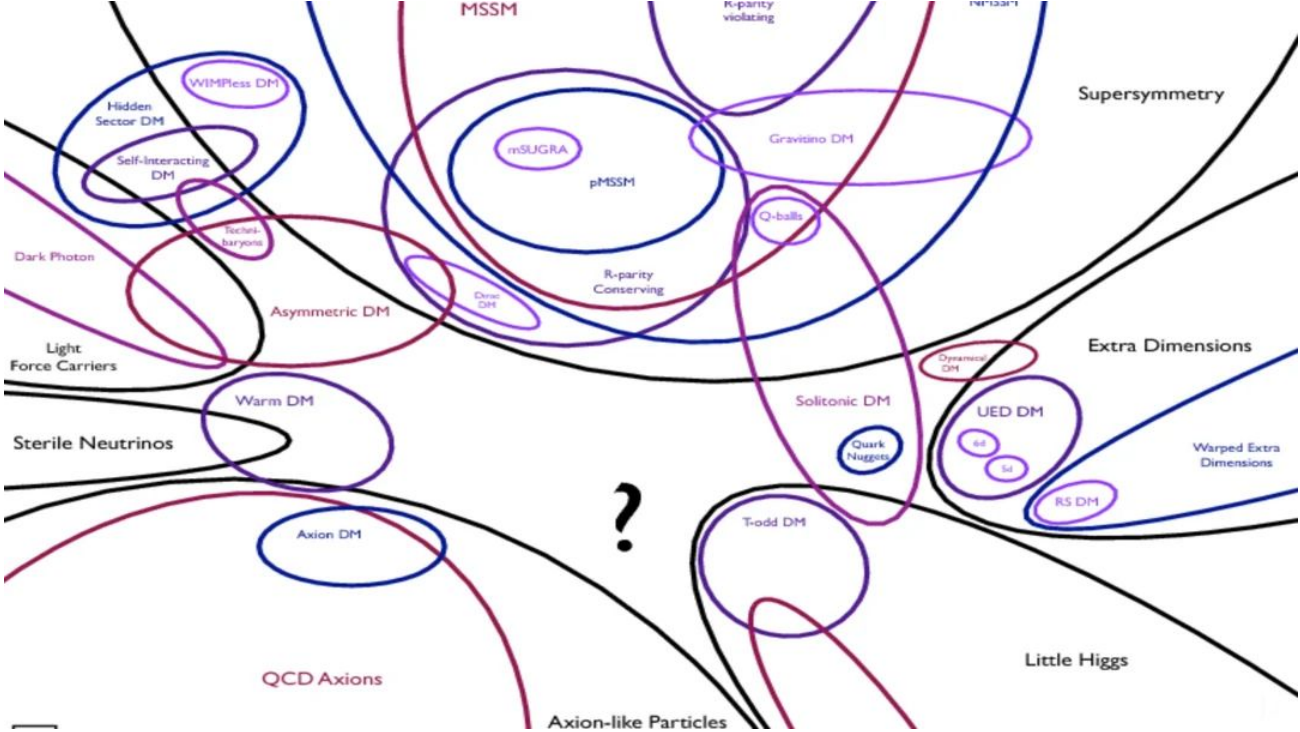

Supersimetria

Standard Model particles



Supersymmetric partners

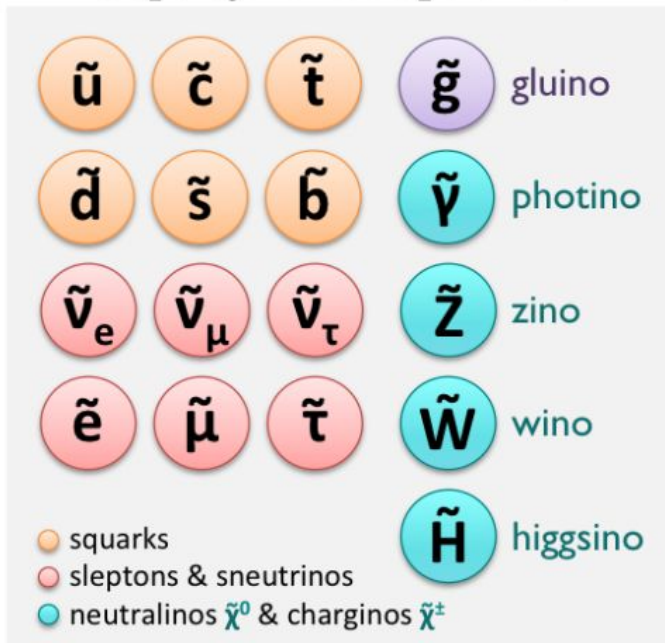

Supersimmetria

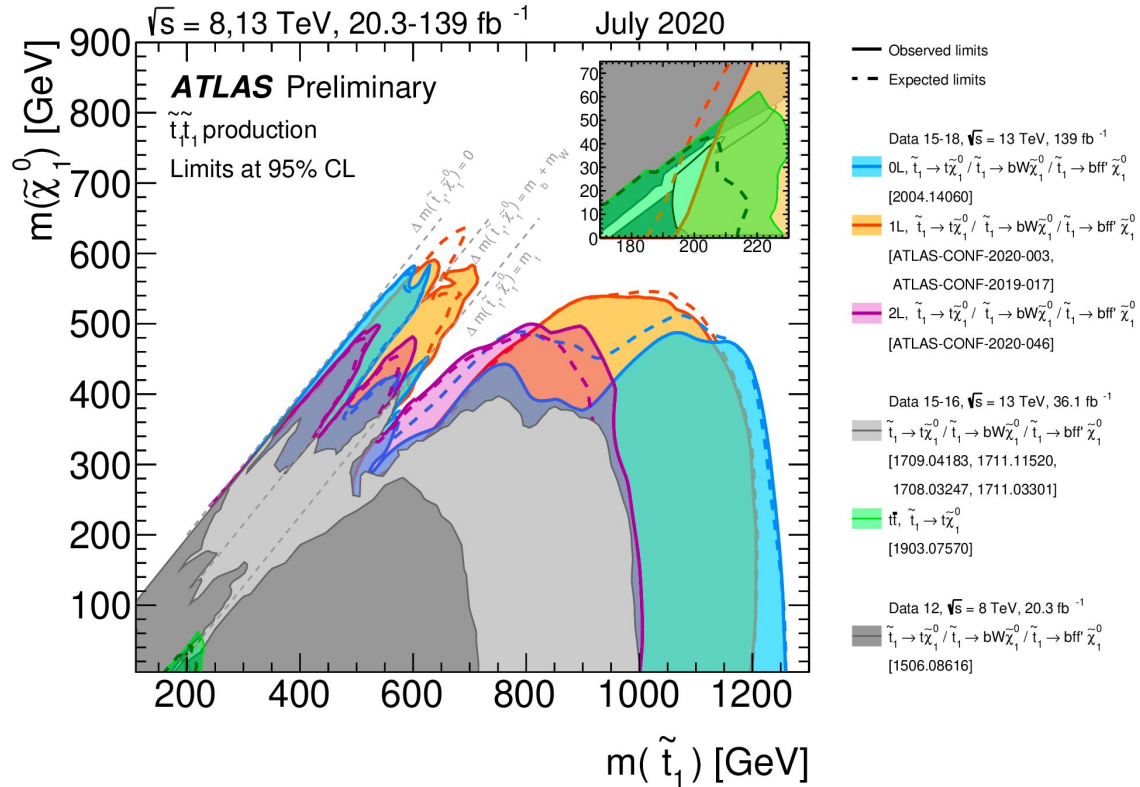

Procurar novas partículas pesadas

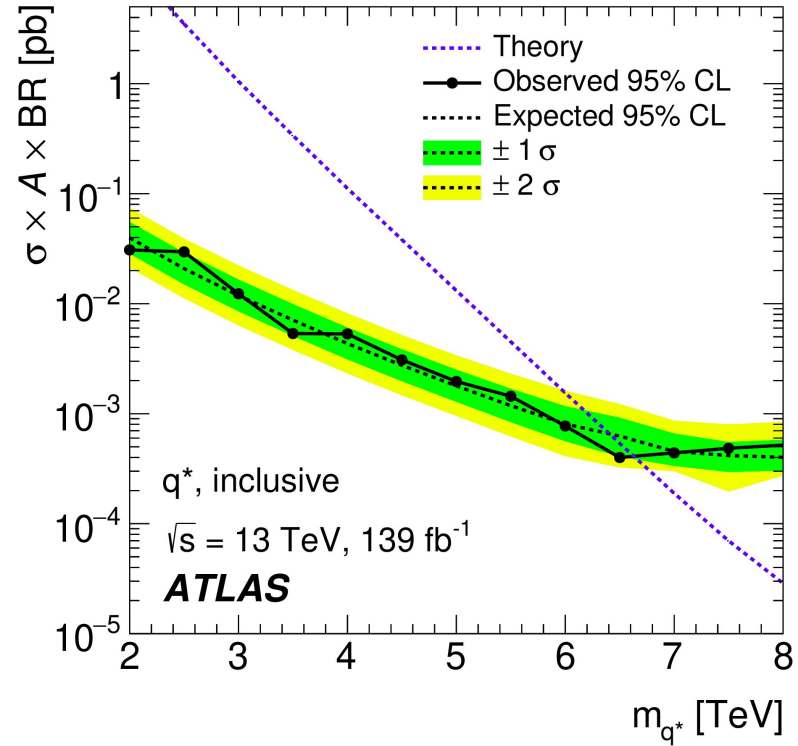
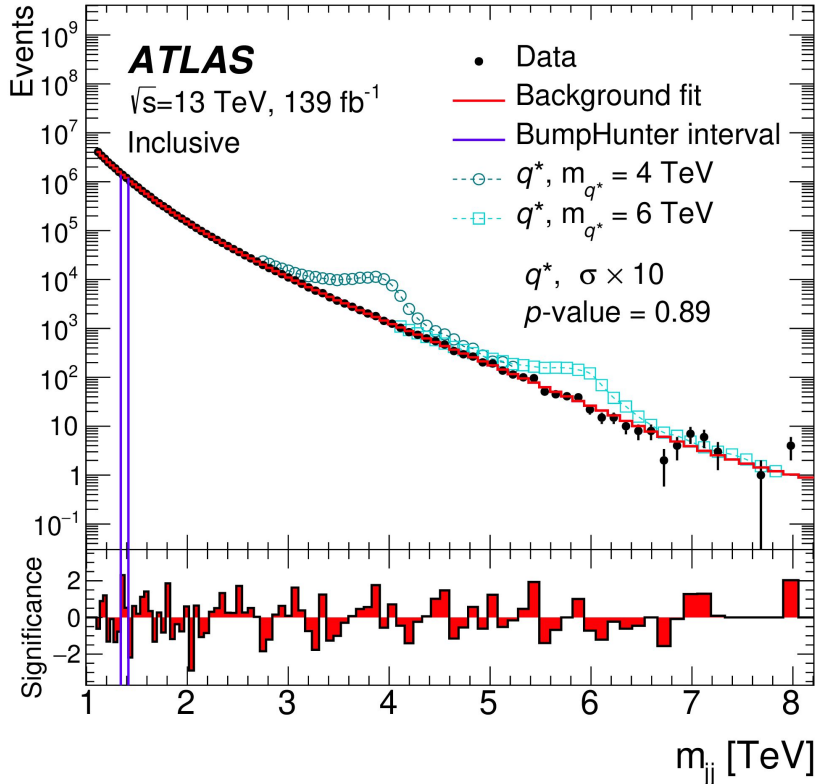

O futuro



LHC / HL-LHC Plan

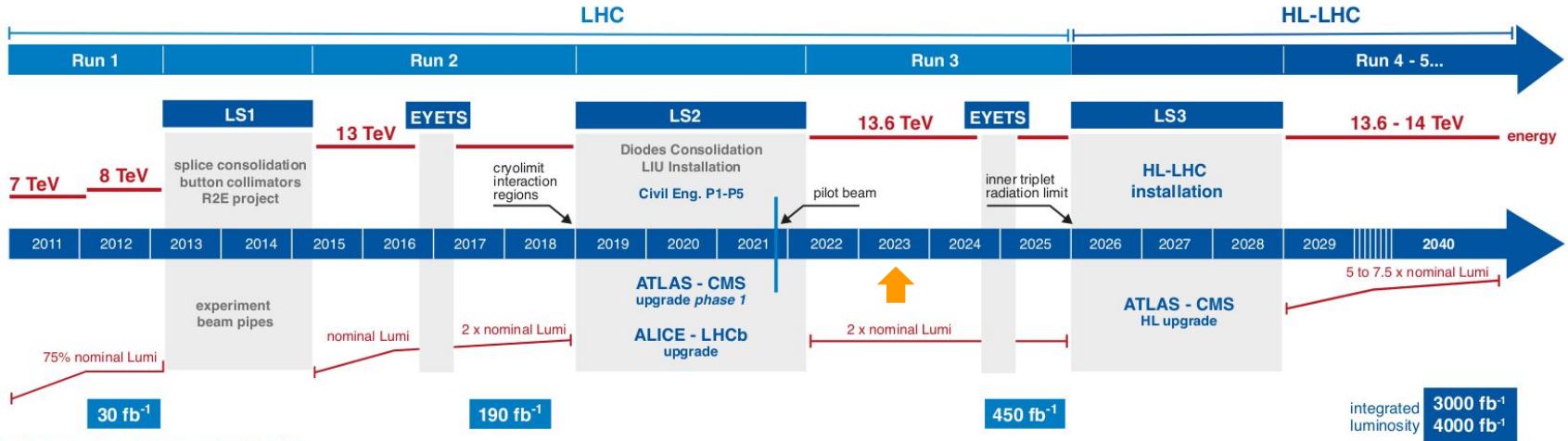

HL-LHC TECHNICAL EQUIPMENT:



HL-LHC CIVIL ENGINEERING:



O futuro mais longínquo

Possible scenarios of future colliders

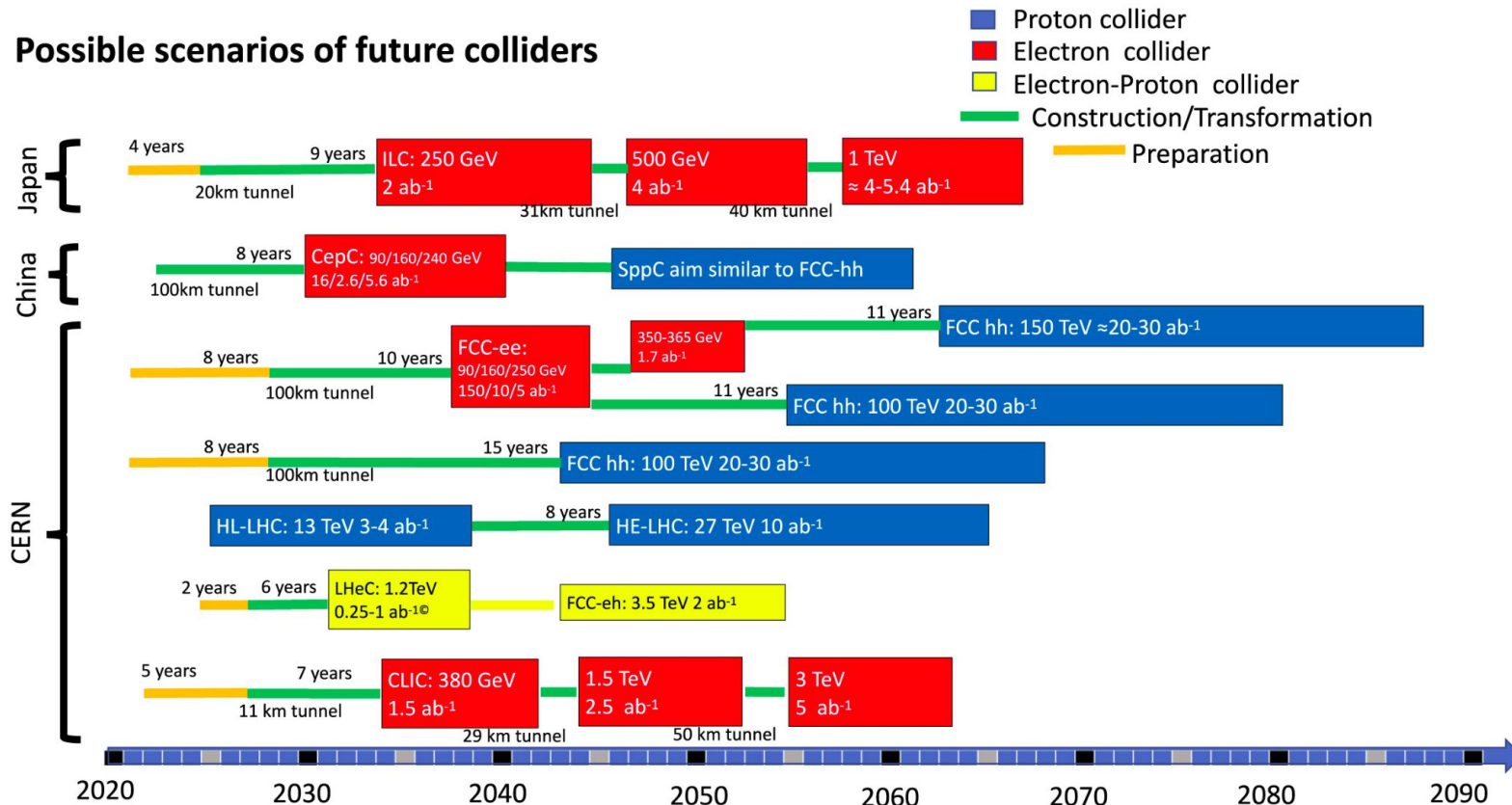

Obrigada

Backup

Modelo padrão da Física de Partículas

- Muões → chuviros atmosféricos
- Neutrinos → Proposto 1930 para garantir conservação energética, observado 1956 em experiências utilizando reatores nucleares
- Tau → SLAC 1970s → Neutrino correspondente

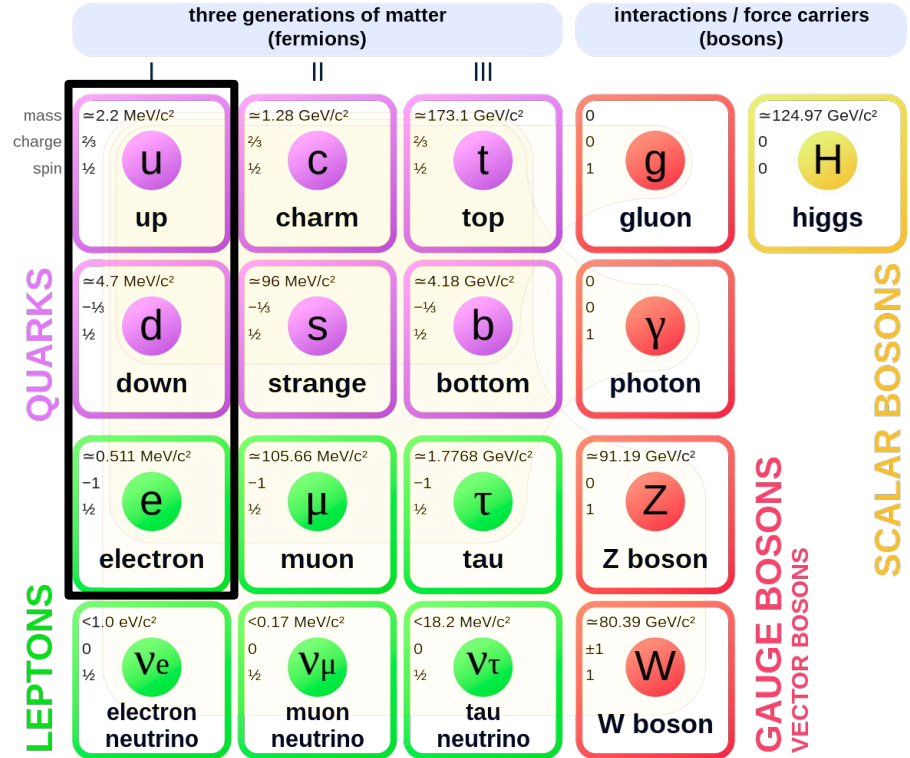

Brasileiros no CERN

Partículas no estado final

Decaimento semileptônico do par de quarks top

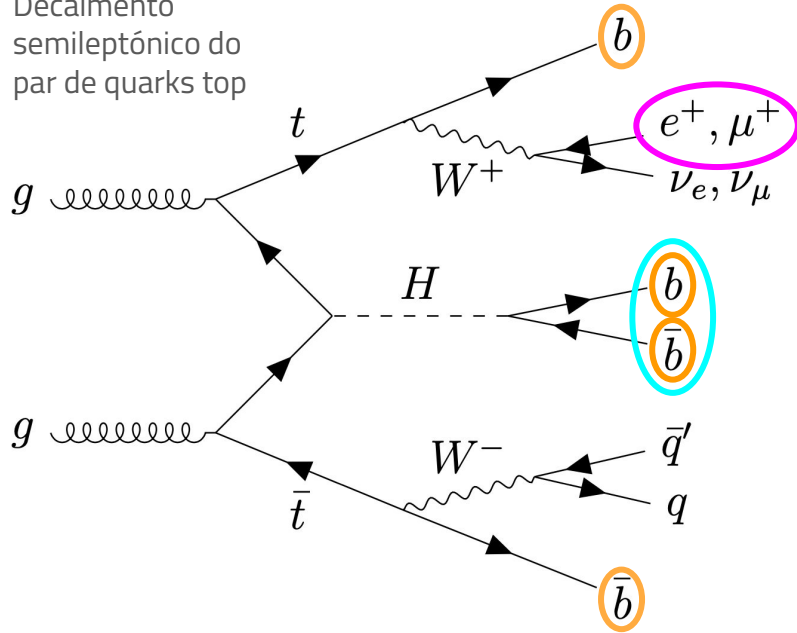

Regime "boosted": bosão Higgs $p_T > 300$ GeV \Rightarrow Produtos de decaimento reconstruídos como um único jato

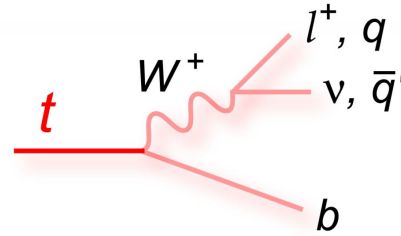

Ambos bosões W decaem leptonicamente
Canal dileptônico

≥ 4 jatos, ≥ 4 jatos b (2 do Higgs)
= 2 leptões

Um bosão W decai hadronicamente
Canal semileptônico

≥ 6 jatos, ≥ 4 jatos b (2 do Higgs)
= 1 leptão

Como medimos?

Comparar um modelo (com pelo menos um parâmetro livre) com dados experimentais de modo a determinar o valor do parâmetro que melhor descreve os dados

$$\mathcal{L}(\mathbf{n}, \theta^0 | \mu, \theta) = \prod_{i \in \text{bins}} \mathcal{P}(n_i | \mu \cdot S_i(\theta) + B_i(\theta))$$

O nosso modelo: rácio de funções de likelihood

$$q_\alpha = -\ln \frac{\mathcal{L}(\alpha, \hat{\kappa}'_t[\alpha], \hat{\theta}[\alpha])}{\mathcal{L}(\hat{\alpha}, \hat{\kappa}'_t, \hat{\theta})}$$

Mínimo da função de likelihood para um valor de α fixo

Mínimo absoluto da função de likelihood

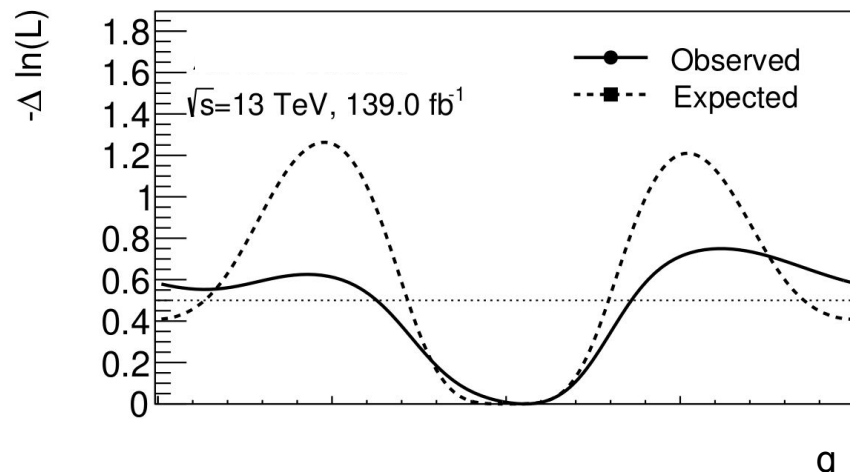

O resultado

