

ITS3 Update : wind tunnel

Quality problems with 3d printed CYSS : Shell is 1mm twisted
Design of a new one using carbon shell from previous layout

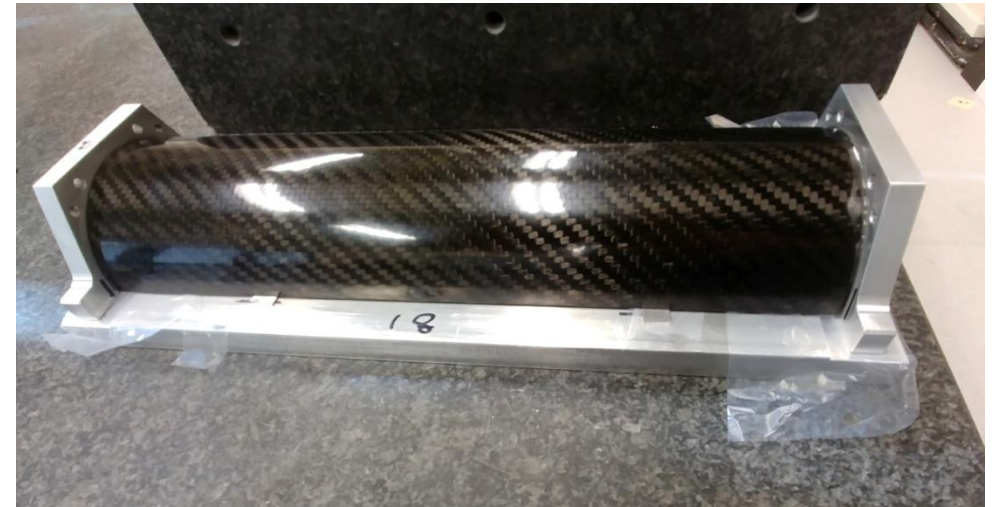

ITS3 Update : wind tunnel

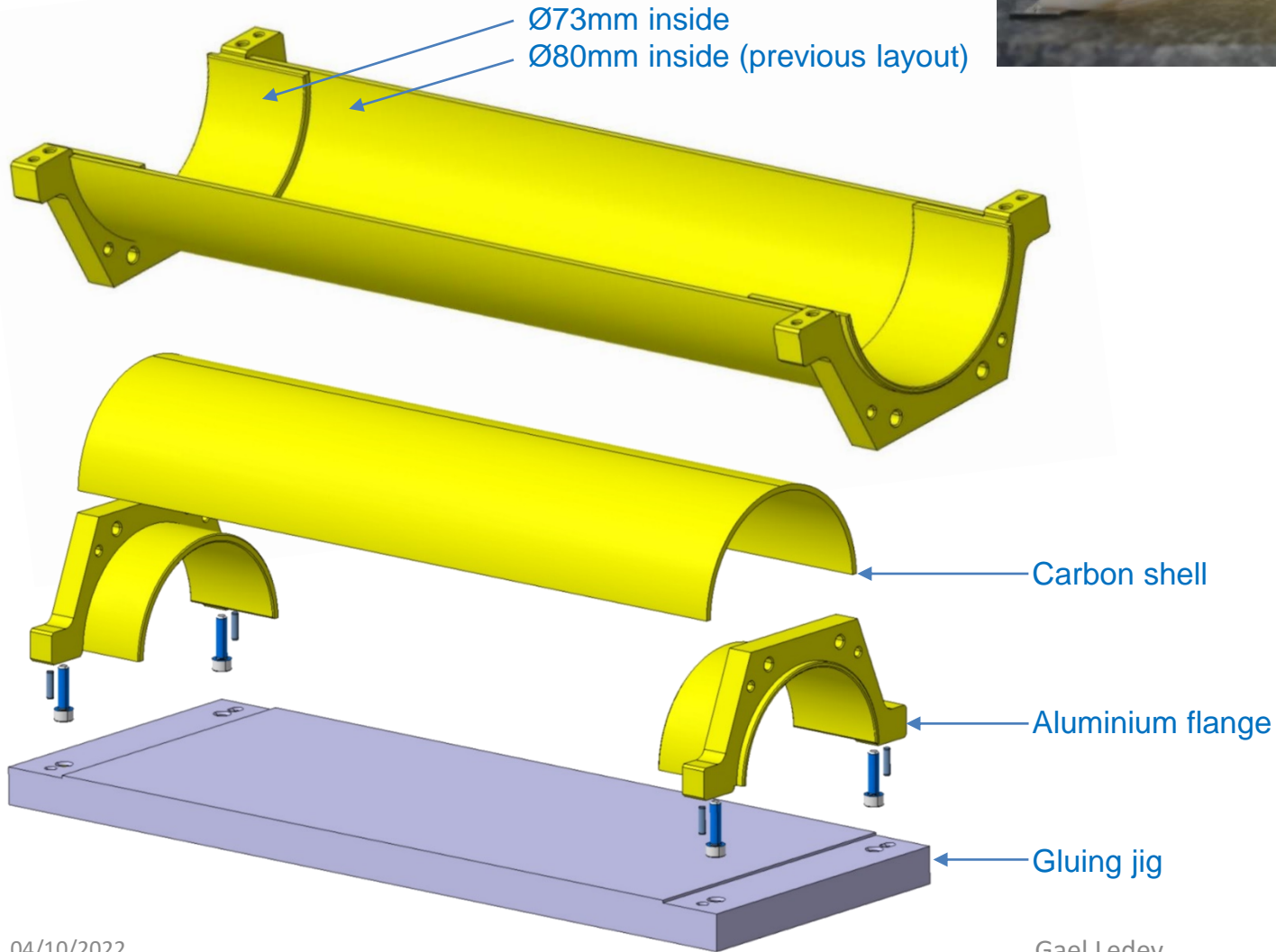
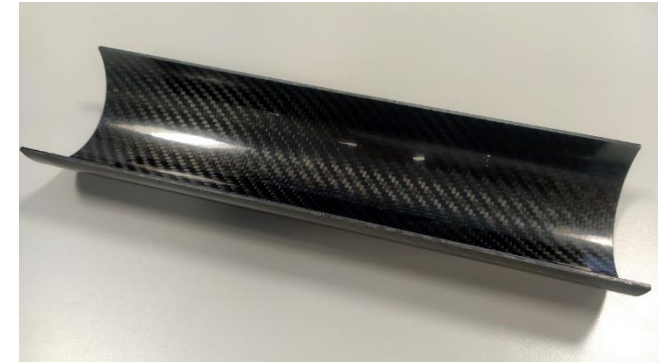
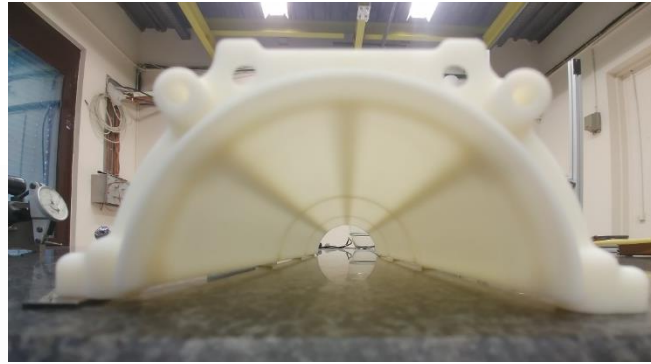
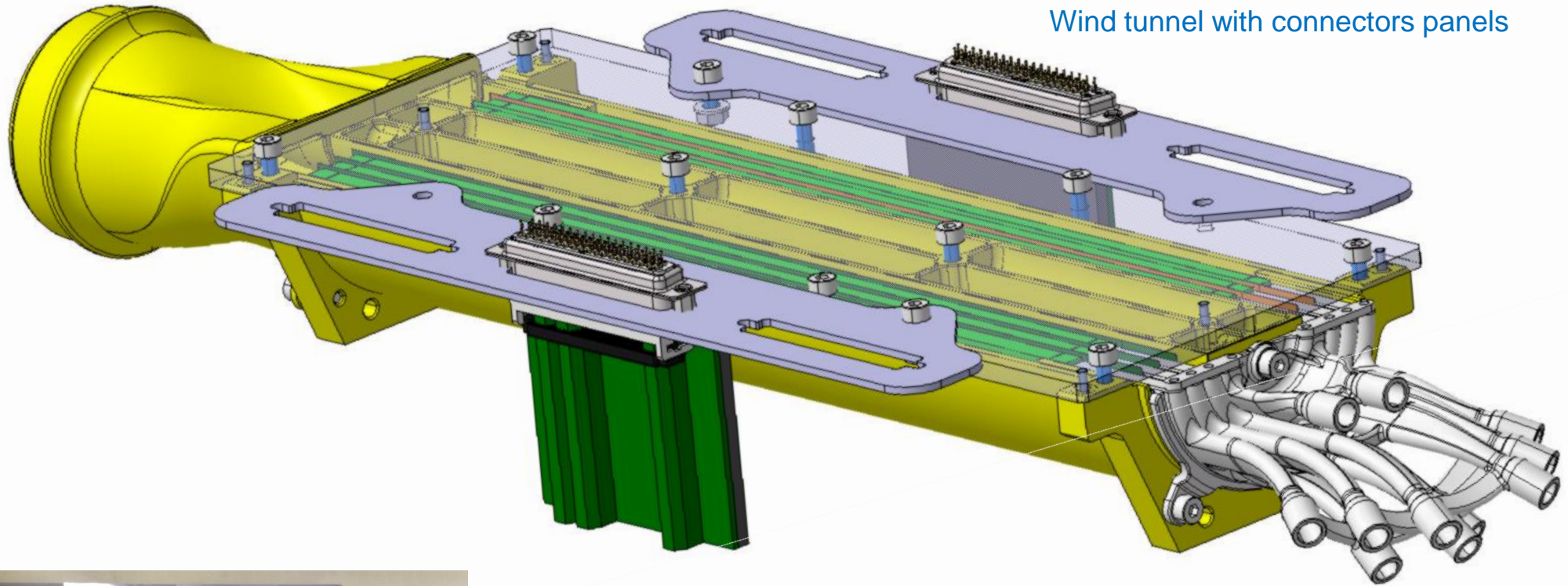

Wind tunnel with connectors panels

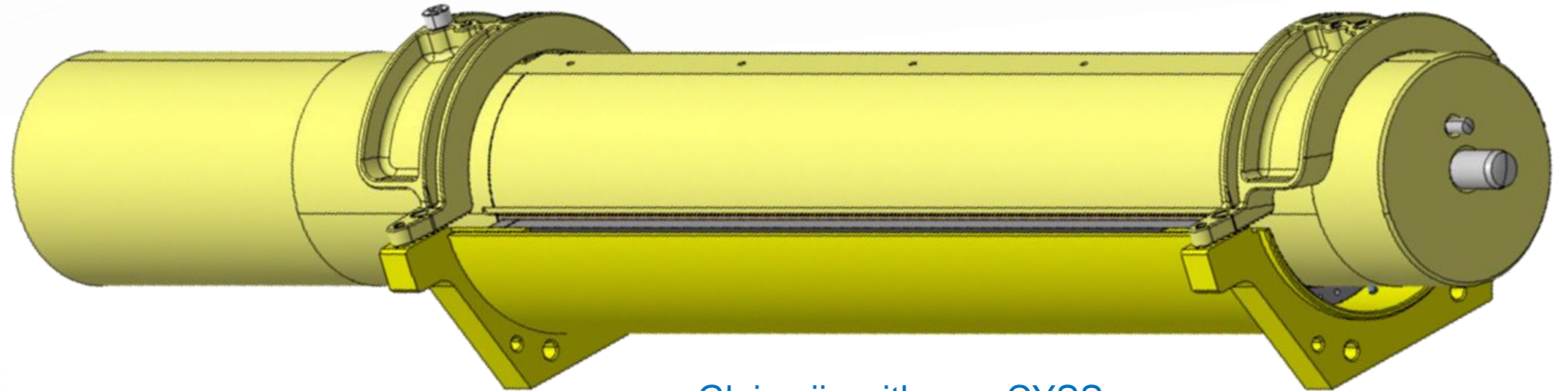
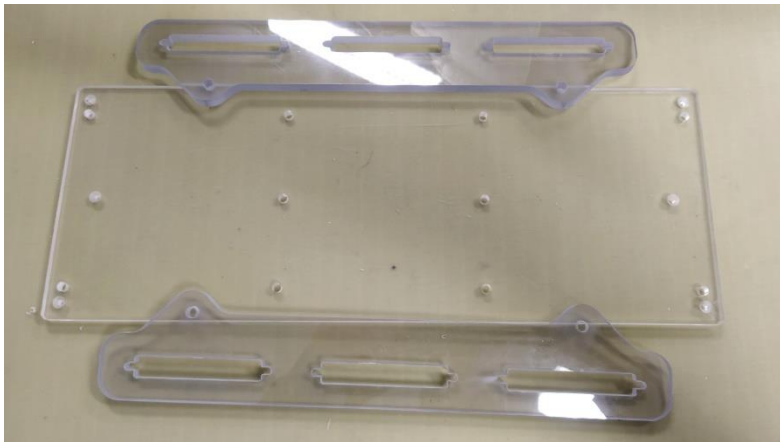

Gluing jig with new CYSS

ITS3 Update : wind tunnel

