

IFAST IIF PITCH

“HIGHEST”

High-Temperature High-Gradient Superconductors

CERN

CSIC-ICMAB (public research center, ES)

Ceraco (private company, DE)

SLAC as supporting partner



Submitted by:
Sergio Calatroni
Principal applied physicist

Background and aim

- High-temperature superconductors (HTS) were discovered in 1986 and until now have never been used in a high-power microwave device, like an accelerating structure.
- We believe that with this proposal we can push HTS fabrication technology over the last hurdle and demonstrate operation in such a device
- HTS-based accelerating structures would open many opportunities of new, higher-performance, more efficient and more sustainable accelerator rf system
- We have already demonstrated:
 - Successfully **applying 2D HTS tapes in 3D geometries**
 - Measuring a **higher quality factor** of these HTS coated RF cavities at low power
- We want to develop and optimize a 3D coating technology and demonstrate its scalability to make practical RF high power devices

Technical overview - 1

- We have developed a technology for applying 2D HTS tapes to 3D RF “RADES” cavities demonstrating the potential of HTS for RF applications [J. Golm et al., IEEE TAS, Vol. 32, No. 4, \(2022\) 1500605](#)

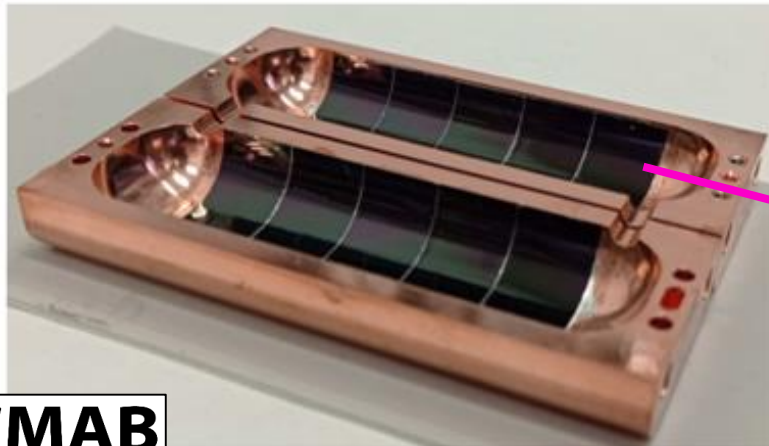

RADES cavity

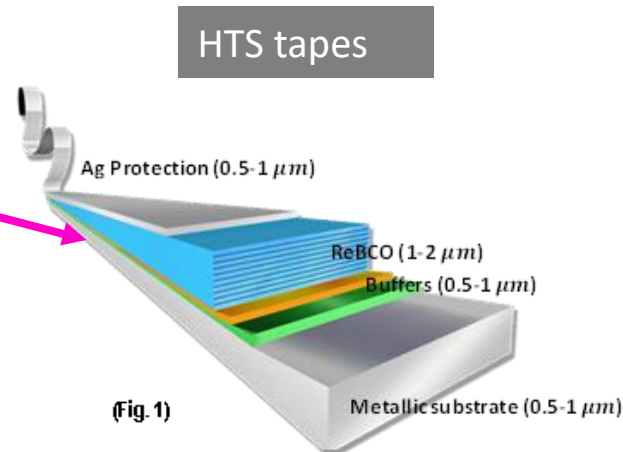

2x improvement of RF quality factor compared to copper
(new prototype 5x improvement)

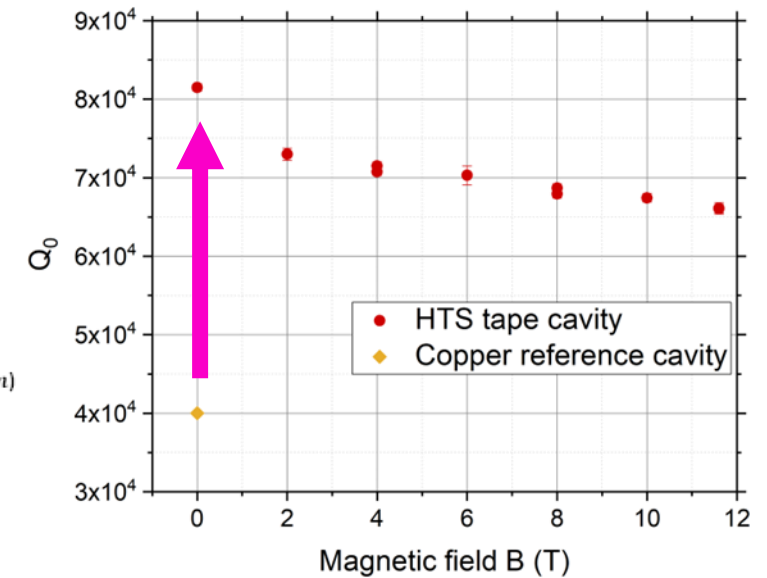

Technical overview - 2

- A potential improvement at least x10 compared to copper has been measured on samples of tapes (8 GHz) at low RF power

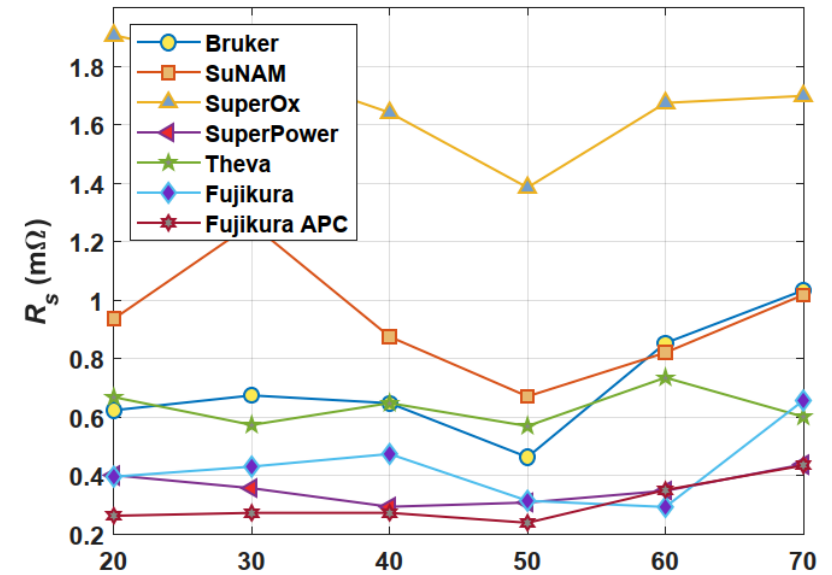
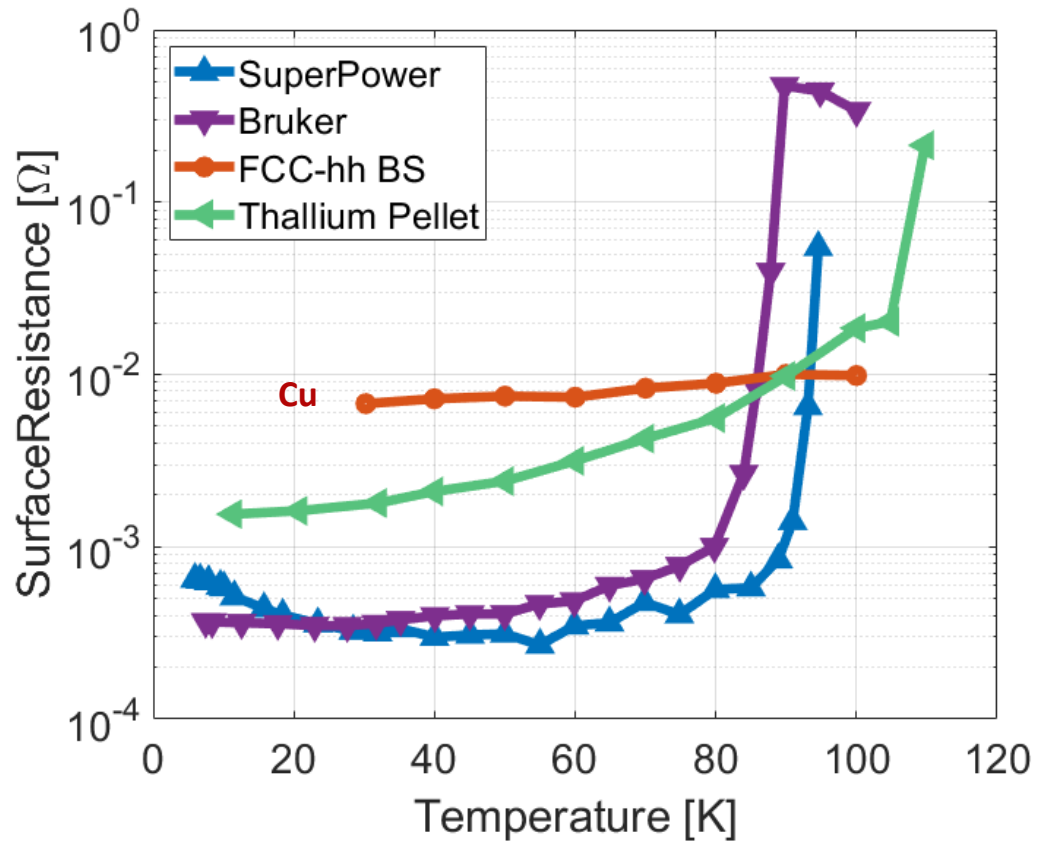

(adapted from Romanov et al, [Sci. Rep. \(2020\) 10:12325](#))

Technical overview - 3

- There are very few measurements on HTS at high RF currents (mostly microstrip resonators). But **physics is proven**.

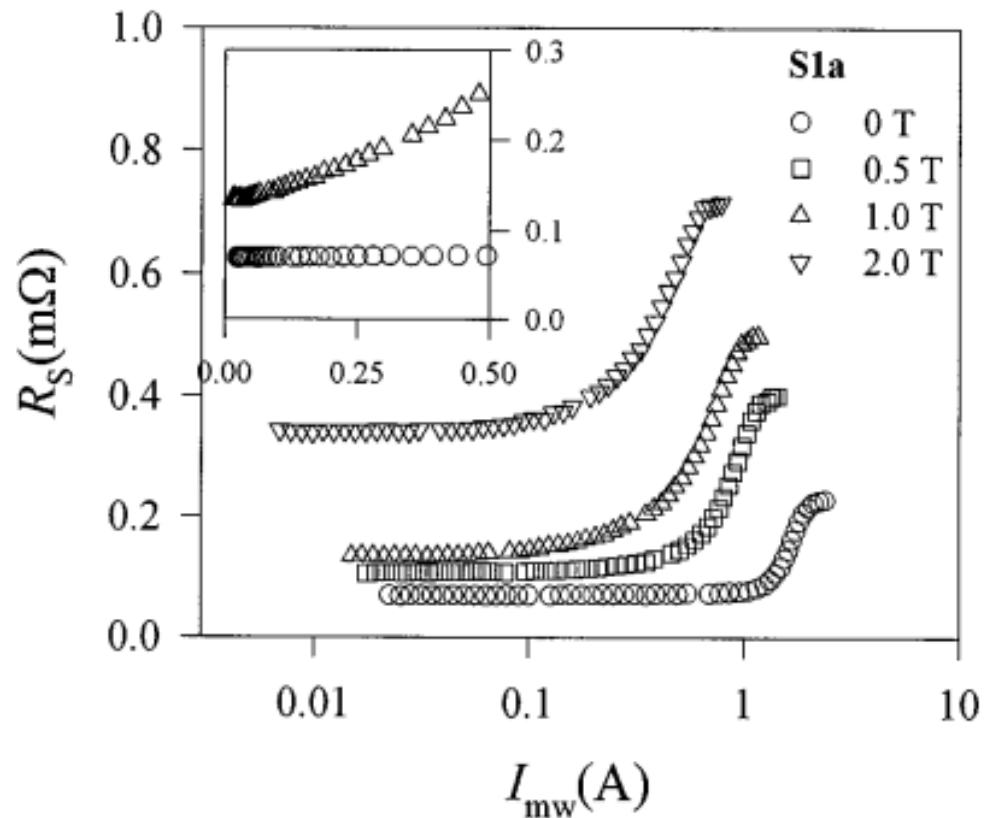

1 A RF equivalent to 2.8×10^6 A/m
(microstrip 200 μm , 350 nm thick, 8 GHz, 30 K)
Equivalent to 780 MV/m in an elliptical cavity

Powell et al. [Journal of Applied Physics 86, 2137 \(1999\)](#)

Technical overview - 4

- We have developed **first prototypes of 3D direct HTS coating**



Inclined deposition technology
(fixed substrate)

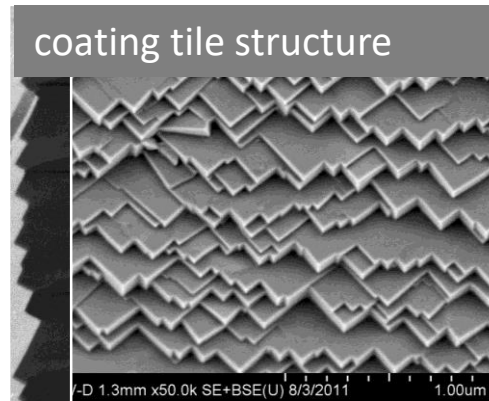
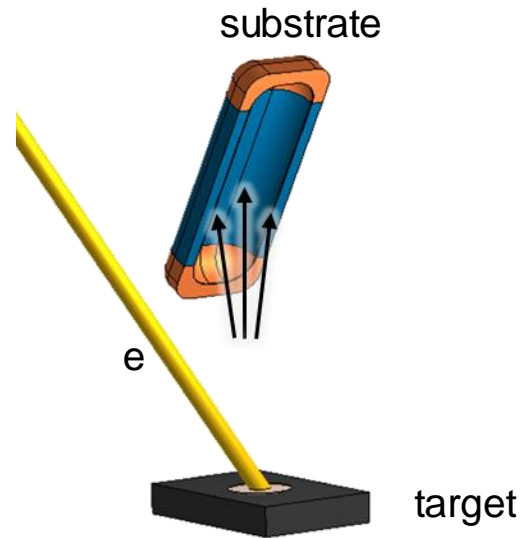

(unpublished results)

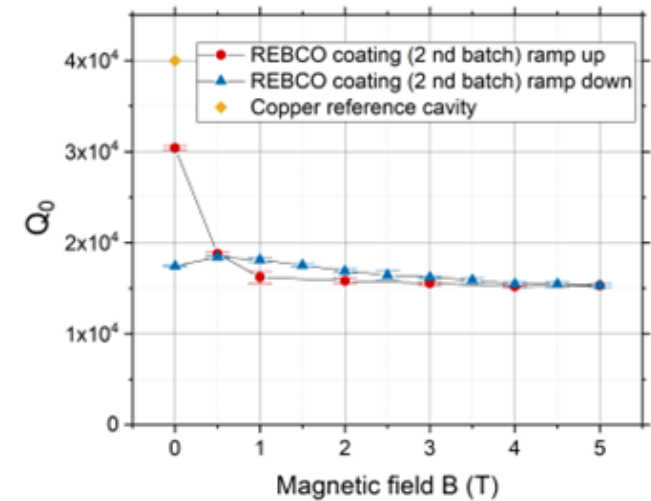

- We want to **improve direct-3D coating** by implementing a substrate rotation and control mechanism, to allow uniform coating.
- We think that **for accelerator applications**, perhaps at lower frequency, **this is the road to pursue**

Technical proposal - 1

➤ The coating must reach the cavity surface at ideal angle everywhere
 Proposal for 3D coating technique (Ceraco)

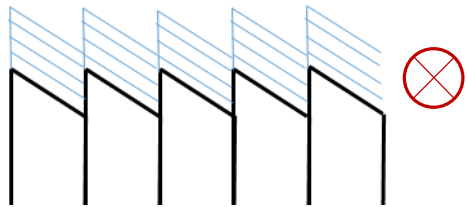

Current flows along tile structure
 High critical current density

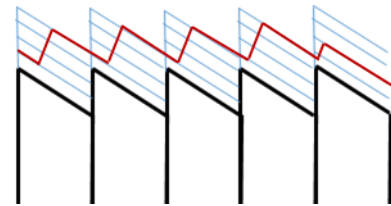

Current flows across tile structure
 Low critical current density



Cu disc, to be coated with HTS and tested at SLAC with "mushroom cavity"

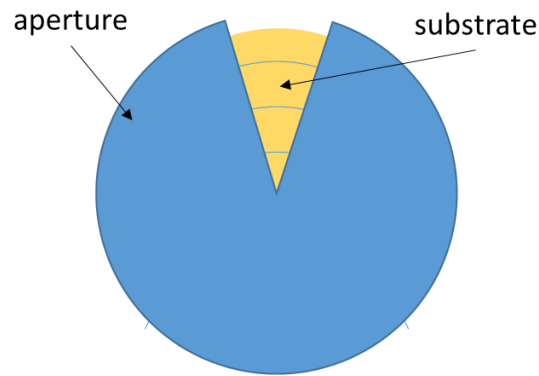

Development of substrate rotation for inclined deposition

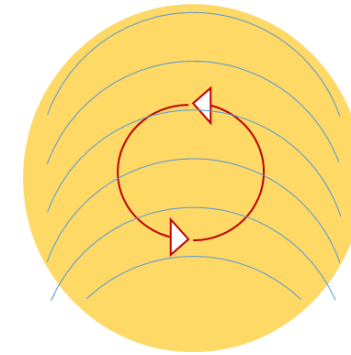
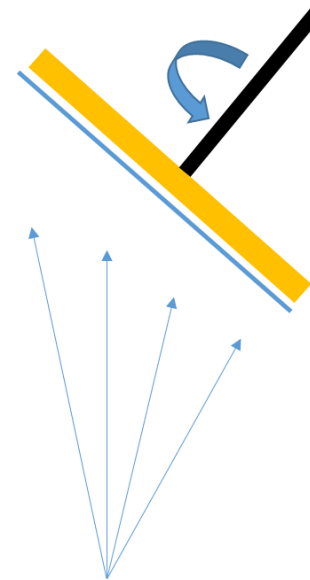

No rotation during coating:
 RF currents cross the tile structure

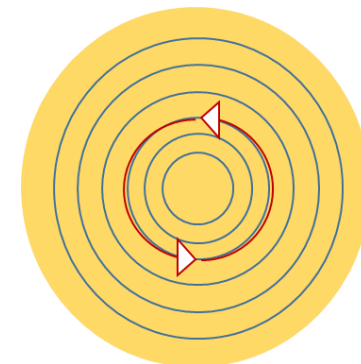

With rotation:
 RF currents will flow along the tiles

Technical proposal - 2

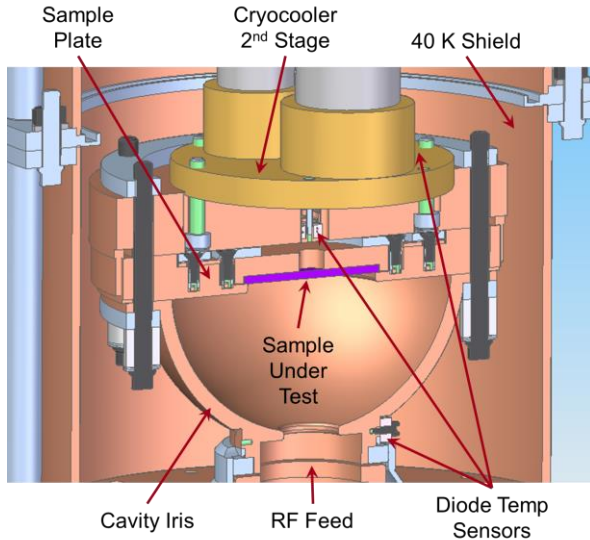

- High-Q X-band hemispheric cavity with a TE_{032} -like mode at 11.4 GHz.
- Zero E-field on the sample
- Maximum H-field on the sample
- Sample accounts for $\frac{1}{3}$ of total cavity loss

- Demountable high-power RF cavity
- Cavity O.D. = 142 mm
- Can achieve H_{peak} of about 360 mT using 50 MW XL-4 Klystron.

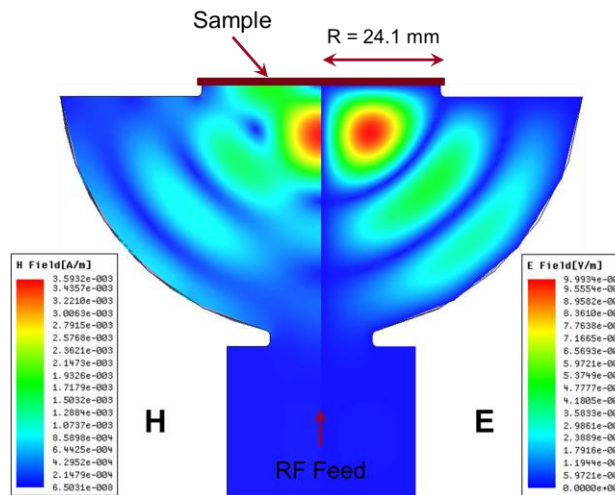

HTS-coated with tapes
By CSIC-ICMAB

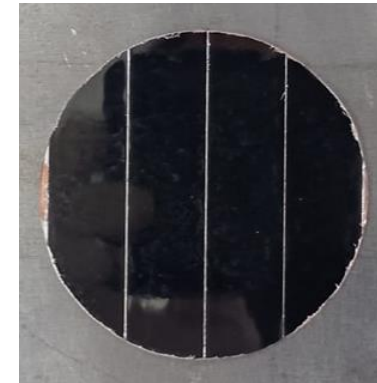

HTS-coated sample
By CERACO

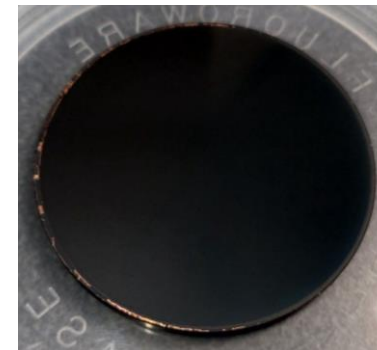

Technical proposal - 3

- Device approach: X-band pulse compressor (SLAC) as first “real” device
- Coated with tapes by CSIC-ICMAB for device validation
- Direct 3-D coating best option for future large-scale production

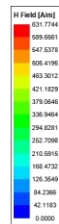
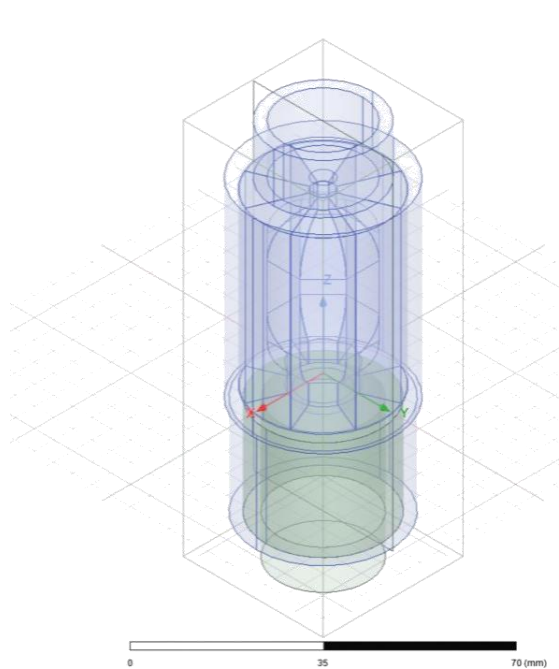

Courtesy Greg LeSage,
SLAC

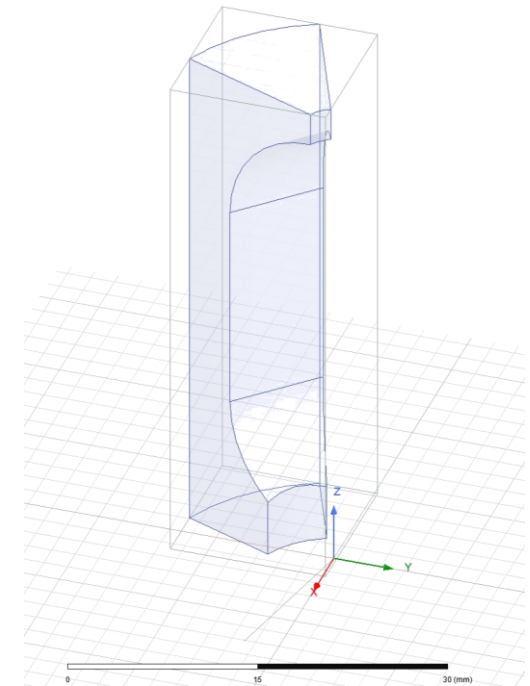
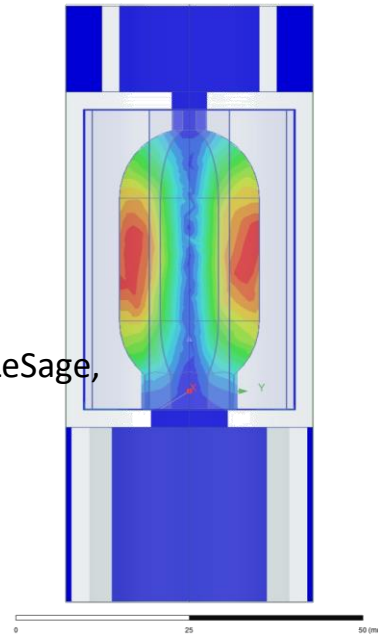

Max field surface 3.126 MA/m

For information only

➤ Approach being validated also for cavities for axion detection in RADES, independently funded

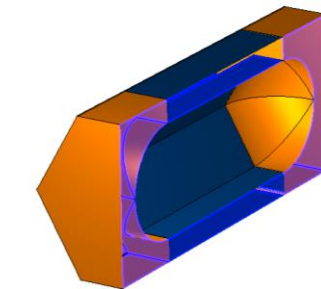
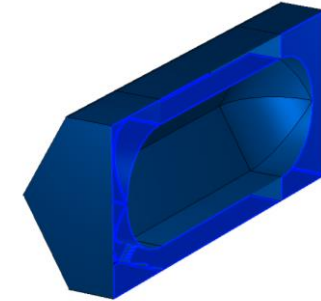
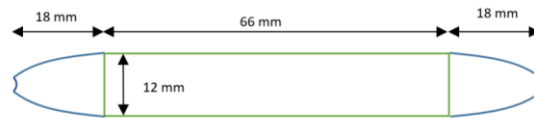
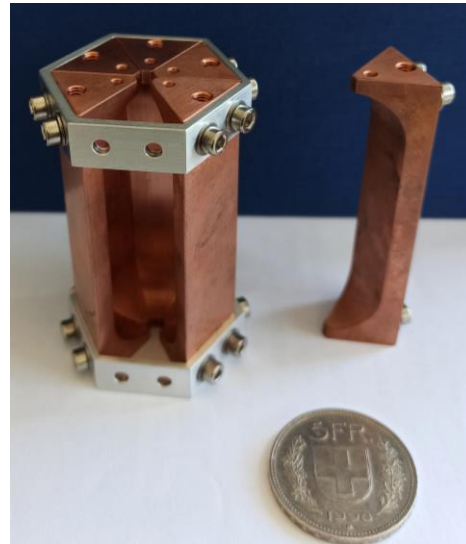
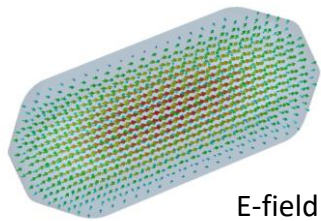
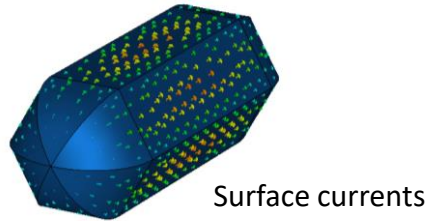
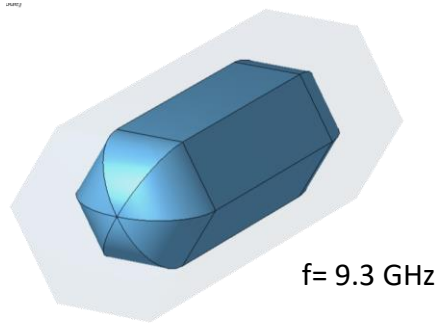

Addressing the European Green Deal

Benefits



fresh air, clean water,
healthy soil and
biodiversity



renovated, energy
efficient buildings



healthy and affordable
food



more public transport



cleaner energy and
cutting-edge clean
technological
innovation



longer lasting
products that can be
repaired, recycled and
re-used



future-proof jobs and
skills training for the
transition



globally competitive
and resilient industry

Actions



RPowerEU



Energy



Agriculture



Industry



Environment and oceans



Climate



Transport



Finance and regional development



Research and innovation

- New-generation collider linacs are expected to use hundreds of MW of electricity
- Energy savings from HTS are in line with current policies of societal impact minimization

Future view - 1

- The [C³ study](#) aims at cryogenically cooled copper
- Goal is to combine the advantage of higher gradients at lower temperatures, with the higher Q factor of HTS coatings -> **energy efficiency**

TABLE I. Summary of the accelerating parameters of the distributed-coupling accelerating structure at 300 and 77 K. The peak fields are calculated for an average accelerating gradient of 100 MV/m.

Parameter	300 K	77 K
Frequency (GHz)	11.402	11.438
Q_0	10000	22500
Q_{ext}	10000	10000
Shunt impedance (M Ω /m)	155	349
Peak surface E (MV/m)	250	250
Peak surface H (MA/m)	0.575	0.575
Steady state rf power (MW)	17	9
Iris diameter (mm)	2.6	2.6
Length (cm)	26	26

Cryoplant efficiency (Carnot + engineering)

SRF temperature	Ratio W_{300K}/W_{cryo}
77 K	13
50 K	20
4.2 K	230
1.9 K	920

Thanks to T. Koettig, CERN

E. Nanni et al., [PRAB 24, 093201 \(2021\)](#)

A factor x10÷20 improvement in Q factor could pave the way for major energy savings

Future view - 2

➤ How could it be done in practice in a future cavity? **Bimetallic cavities**



J. Haimson, WEPMS085,
PAC07 (s.steel inserts)

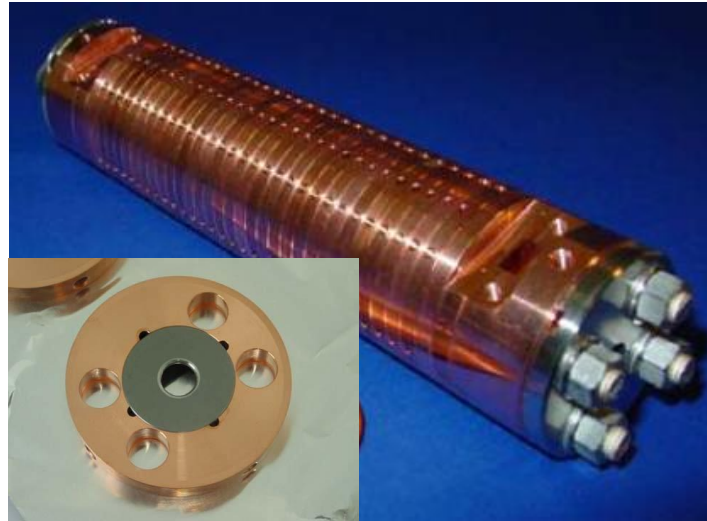

CLIC Mo-iris prototype

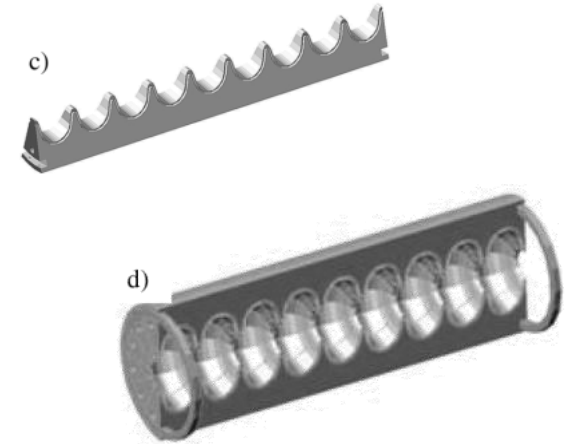

P. McIntyre et al., IEEE TAS
19 (2009) 1380

Work plan and risk mitigation

	Q1	Q2	Q3	Q4	Q5
WP 1 (CERN)					
Coordination activities					
Samples and substrates procurement		M1			
RF low power characterization of 2D coated segmented cavities			D1		
Final report					D2
WP 2 (Ceraco)					
Design and fabrication of sample holder rotation system	M1				
HTS 3D coating of disc samples			D1		
WP3 (CSIC-ICMAB)					
2D coating on discs and segmented cavities for benchmarking	D1				
Measurement of superconducting properties of 3D HTS coatings				D2	
SLAC supporting partner					
RF high power characterization of 3D coated HTS discs in their mushroom cavity					

Risk	Mitigation
Segmented test cavity delayed	HTS optimization studies to be performed with older "RADES" cavities
Quality of 3D coatings on discs	Measurement of superconducting (non-RF) properties at ICMAB will help in optimization work
High power characterization at SLAC delayed	Preliminary low-power characterization is possible with standard laboratory devices

Applications, impact, business and commercialization

- The **accelerator sector will be the primary target** of our work.
 - Future high-energy or high-power linacs
 - Compact, low-power consumption linacs for medical devices, light sources
- The HTS technology will be applied at industrial scale
 - IP ownership is within CERN and CSIC-ICMAB for 2D coatings with commercial tapes.
 - IP ownership will be within Ceraco and CERN for 3D coating technology. **This technology can be patented** (HTS 3D coating technology and methods), and IP rights commercialized
- Our next step will be to launch a new round of fund raising for manufacturing and 3D-coat a prototype of a real-size high power RF device
 - This will include the design, fabrication and coating, and its validation in a high-power RF bench test bench.
 - We have the interest and support of a major player in RF technology as SLAC, who will design and test the prototype
- A proper business and commercial plan will be finalized upon successful completion of the present study

Industrial application prospect

- At the end of this study, we aim at consolidating TRL4.
- Prototype pulse compressor with SLAC will demonstrate TRL6.
 - Timescale: 2-3 years after completion of this study
 - Need a further round of funding
 - This will include the design, fabrication and coating, and its validation in a high-power RF bench test bench.
 - Industry will be involved for 3D coating
- Future accelerator projects will drive achieving further TRLs and drive commercialization.
 - Industry will be involved for construction of devices
 - Other companies may be involved for hardware manufacturing

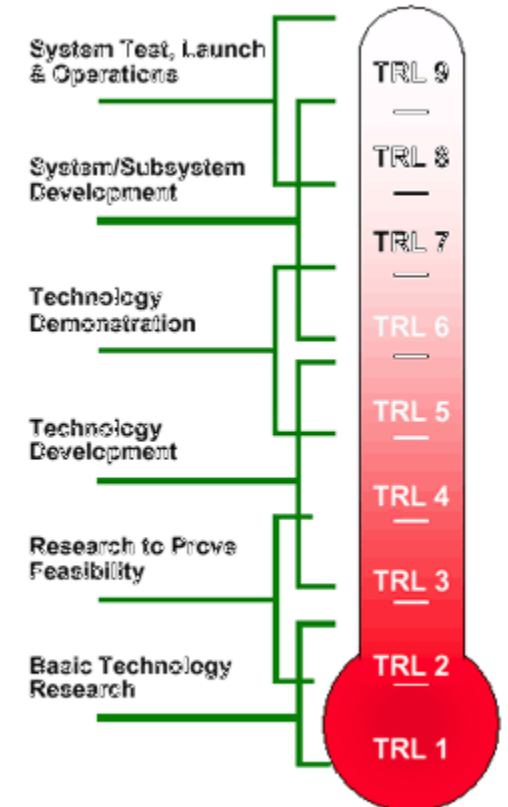

Resources and budget

- CERN:
 - Provided resources: two senior physicist (scientific coordination, 0.2 FTE) and one senior Fellow (follow up, measurements, 0.5 FTE)
 - Requested resources: 10 kEUR (sample manufacturing)
- Ceraco:
 - Provided resources: one senior scientist (design, procurement, coating, 1 FTE)
 - Requested resources: 100 kEUR (80 kEUR manpower for coating operations, 20 kEUR sample holder manufacturing)
- CSIC-ICMAB:
 - Provided resources: one senior scientist (0.2 FTE), and one PhD student (0.5 FTE)
 - Requested resources: 50 kEUR (40 kEUR PhD student and manpower for coating and characterization work, 10 kEUR consumable)

Ratio for the requested IIF funds: 120 kEUR personnel and labour / 40 kEUR material

- Final deliverable is a report on the demonstrated achieved performance, and on the prospects for scalability to accelerator-scale RF devices.

Budget table

	Manpower	Materials	Total
CERN		10 kEUR	10 kEUR
CERACO	80 kEUR	20 kEUR	100 kEUR
CSIC-ICMAB	40 kEUR	10 kEUR	50 kEUR
			160 kEUR

Summary and conclusions

- We aim at demonstrating that HTS can be used in high-gradient applications:
 - Background physics was already proven
 - Technology for use of 2D tapes is available (CSIC-ICMAB)
 - We want to develop **3D coating technique adapted to RF-cavity surfaces**
- Plan:
 - **Develop 3D coating technique** for discs (coating texture parallel to RF current lines) (**Ceraco**)
 - Superconductivity and structure **characterization at CSIC-ICMAB**
 - RF test at **high power at SLAC** (mushroom cavity)
 - In parallel, **design prototype pulse compressor** (SLAC) and **coat with tapes** (CSIC-ICMAB) to prove device feasibility
 - Coordination and sample fabrication by **CERN**
- Future work will be aimed at full device coating by 3D techniques
 - Funding to be identified
 - First results can be aligned with future ESPP, allowing identification of potential market

Contact information

Primary Contact

NAME: Sergio Calatroni

TITLE: PRINCIPAL APPLIED PHYSICIST

PHONE: +41227673070

MOBILE: +41 75 4113613

E-MAIL: sergio.calatroni at cern.ch

WEBSITE: <https://home.cern/>

SOCIAL MEDIA:  

TECHNOLOGY INNOVATIONS DIRECTORATE

Dr. Sergio Calatroni
Sergio.Calatroni@cern.ch
CERN, 1211 Geneva 23,
Switzerland

Emilio Nanni, Ph.D., Assistant Professor of Photon
Science and of Particle Physics and Astrophysics
Applied Electromagnetics Department Head
Technology Innovation Directorate, SLAC National
Accelerator Laboratory, Stanford University
2575 Sand Hill Road
Menlo Park, CA 94025
Phone: +1 (650) 926-4818
E-mail: nanni@slac.stanford.edu

14 September 2022

Dear Sergio,

It is my pleasure to write this letter in support for your iFAST proposal "High-Temperature High-Gradient Superconductors."

At SLAC we are interested in the development of high temperature superconductors for a variety of applications including dark matter searches, quantum devices, and accelerator applications. Extending the reach of superconducting technology to high-gradient and high-temperature is particularly exciting as it may open new avenues for developing rf pulse compressors and superconducting rf accelerator cavities, even up to liquid nitrogen temperatures (~80 K). Development of accelerator technology operating at cryogenic temperature of ~80 K is a significant part of our ongoing R&D efforts at SLAC.

In your proposal, the approach you are developing to apply 2D high temperature superconducting (HTS) tapes to 3D geometries has produced exciting preliminary results and further development is critical for developing HTS based accelerator technology. We would gladly collaborate on the testing of HTS samples produced as part of your program. Our recent collaborative effort to test a first HTS sample at SLAC has shown that the infrastructure exists and is available at SLAC to participate in this work. If this work were to proceed to a second phase we would also be excited to jointly develop a full-scale prototype high-power device and test it at SLAC with an X-band high power rf source.

Again, I wish you success on your proposal and look forward to working with you and your team in the future on the development of high-temperature high-gradient superconductors.

Sincerely,

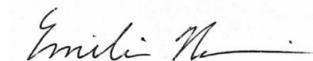

Emilio A. Nanni, Ph.D.





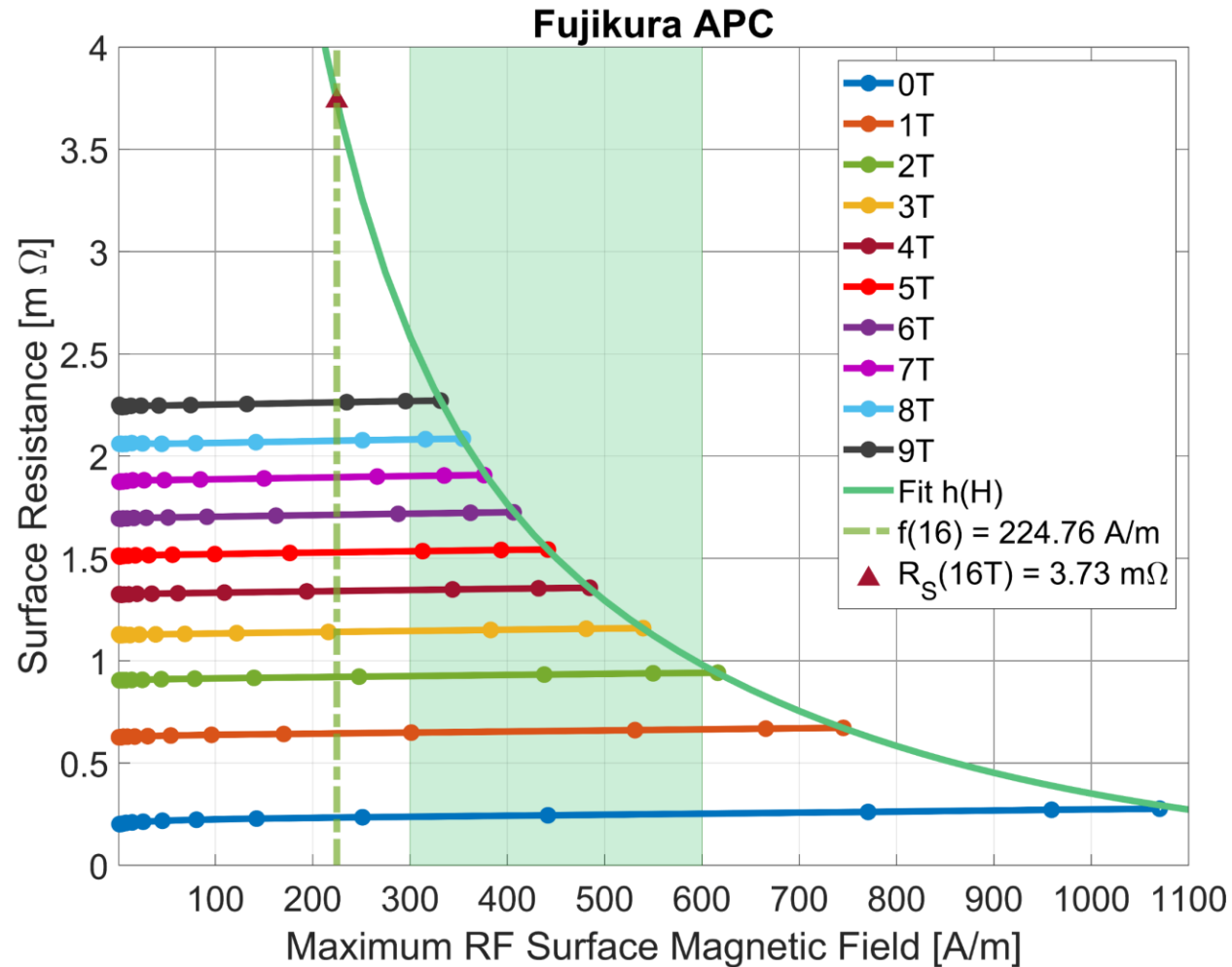

Questions from IIF panel

- ✓ Could you express in quantitative and verifiable terms the improvements with respect to the state-of-the-art that your project is pursuing.
 - ✓ Can the impact of HTS-based accel. structure on accelerator RF systems be better illustrated in quantitative terms ?
 - ✓ The most important parameters to be measured in the characterization, both at low power and at high power, should be described and target values aimed at should be defined and compared with state-of-the-art figures.
 - ✓ Can the sentence "The HTS technology will be applied at industrial scale" be explained in terms of the time scale and the possible level of industrial engagement ?
 - ✓ Is it already clear what results of the R&D work can be patented ?
-
- The budget should be presented in Euro
 - The schedule should extend not later than March 2025 (which is 2 months before end of IFAST)
 - In your presentation we request that at least 1 slide is reserved to expected impact of your project also in term of addressable and obtainable market, and to make a definite statement on how your project addresses the environmental challenges.
 - The precise TRL: where it stands, where you think it will be at the end of the project and the estimated time in the future to reach TRL6.
 - EvB will ask details about the technical aspects of the proposal.

HTS tape at 8 GHz (dielectric resonator)



HTS coating technologies

						
$ReBa_2Cu_3O_7$	Y	Gd Eu	Gd	Gd Y	{ Y,Gd }	Gd
Thickness [μm]	1.6	1.8 2.5	1.6	0.9 3.0	1.5	3.0
Nano-inclusion	BaZrO ₃	none BaHfO ₃	none	none Y ₂ O ₃	BaZrO ₃	none
Technology	PLD	PLD	RCE	PLD	MOVCD	EB-PVD
Substrate	Stainless Steel	Hastelloy C276	Hastelloy C276	Hastelloy C276	Hastelloy C276	Hastelloy C276
Thickness [μm]	100	75 50	100	60 40	50	100
Stabilizer [μm]	e.p. 25	lam. 75	e.p 20	e.p. 10	e.p 20	e.p. 20
T_c [K]	85	94 92	94	94	91	92

RF performance of HTS tapes

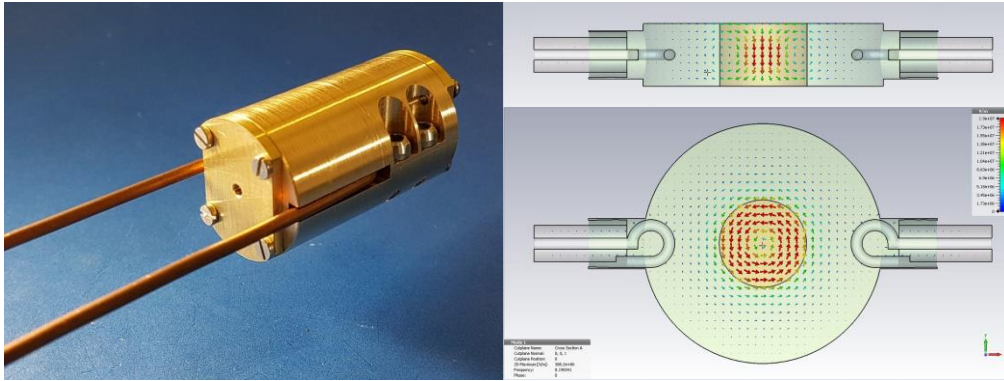

In house developed 8.05 GHz cavity resonator compatible with 25mm bore 9 T magnet at ICMAB

REBCO CCs outperform Cu at 50K and up to 9T
 R_s is microstructure dependent

T. Puig et al., Supercond. Sci. Technol. 32 (2019) 094006 (8pp)

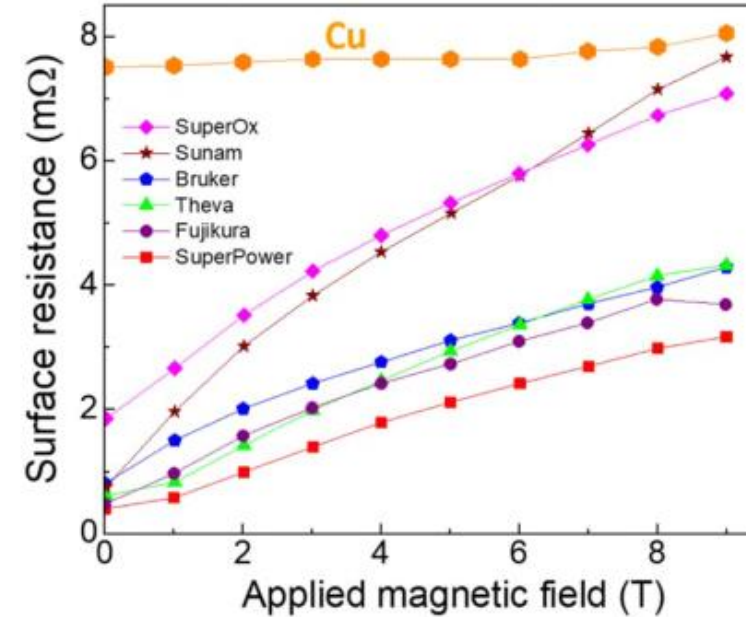
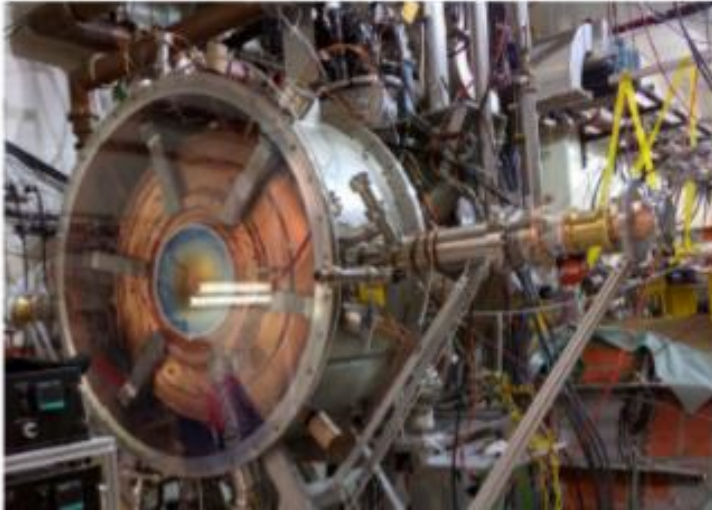
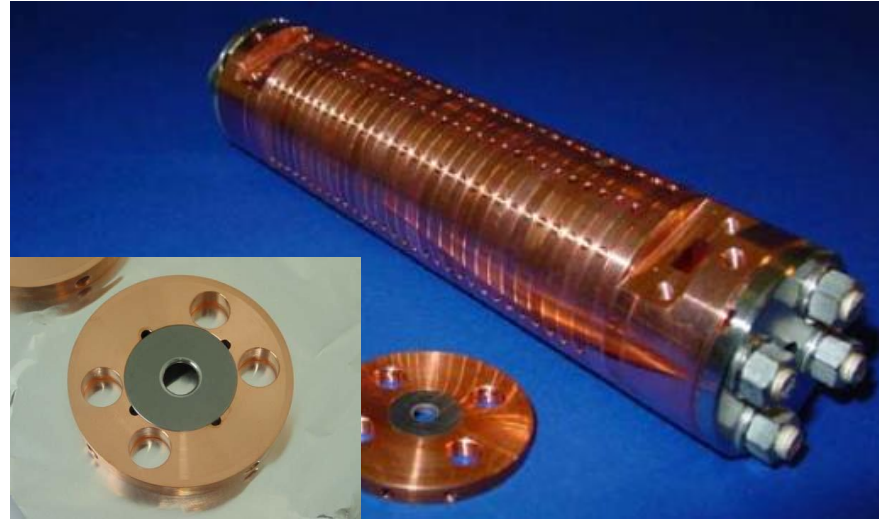

Figure 3. Magnetic field dependence of the surface resistance at 8 GHz and 50 K. Up to 9 T, CCs' R_s outperforms that of copper.

Composite cavities for the muon collider ?



MICE 200 MHz RF module
prototype: 4T, **10 MV/m**, 1ms@1Hz



CLIC Mo-iris prototype

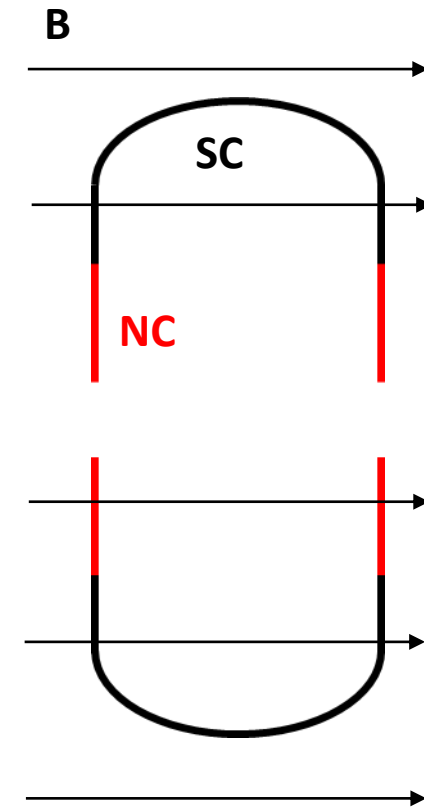

Composite cavities exist and have been demonstrated.

Joints at low-current regions are standard practice even in SRF cavities (ie QWRs)

Segmentation at zero-current region is possible