

Tutorial

Technical Training: Cryostat Engineering for SC devices
CERN, 7-9 November 2022

FCCee, RF cryogenic layout, 400 MHz Cryomodule

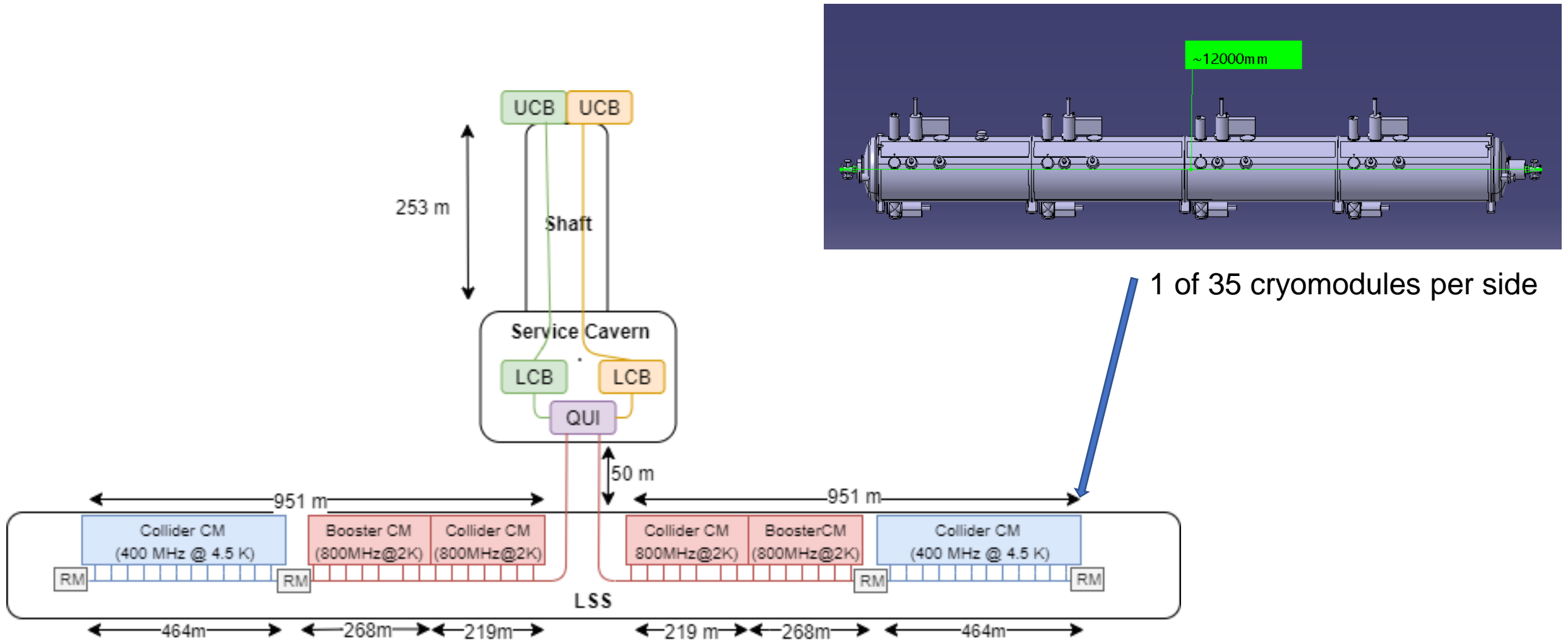

400 MHz cavities, 2-cell

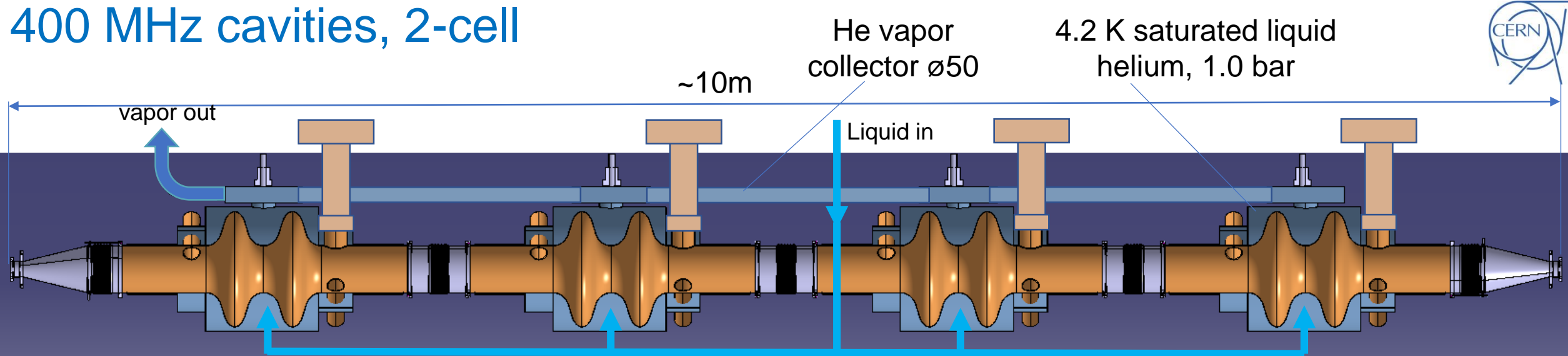

- Cavity: copper, 3-mm thick
- Cavity mass: 150 kg
- Helium vessel: thickness TBD, st. steel (304L grade)
- Helium vessel mass: (304L): 200 kg
- Beam tube cone (304L)
- RF coupler tube (304L)
- Approximate mass of cavity/helium tank/RF coupler assembly: 500 kg

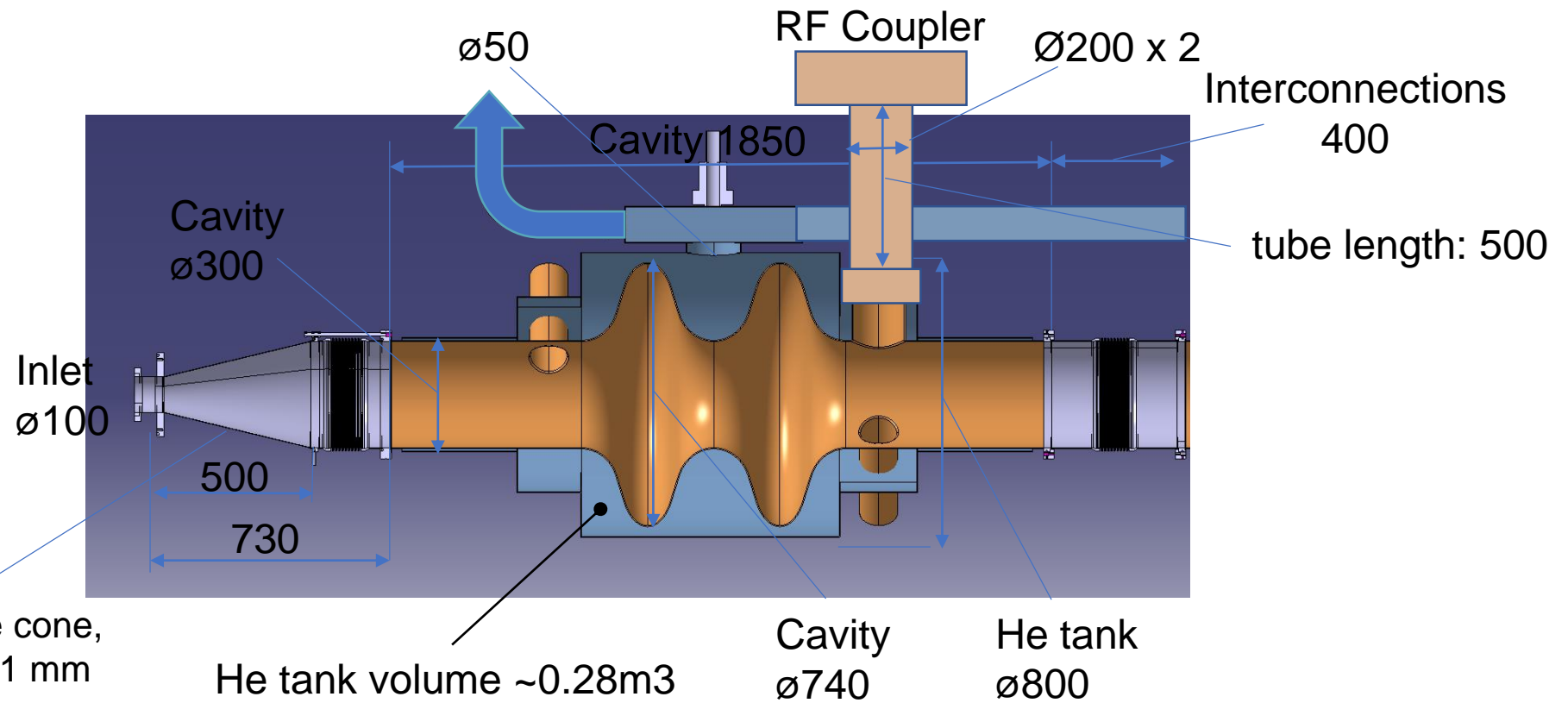

Task 1. Cryostat design

1. Conceptual design of a cryostats for the 400 MHz cryomodule containing 4 cavities. Make a schematic design (simplified sketch, use ppt or any other S/W tool), and make a preliminary engineering design as follows:
 - a. Calculate helium tank thickness, for a maximum allowable pressure of 4 bar
 - b. Calculate vacuum vessel: material, diameter and thickness
 - c. Calculate thermal shielding: material, diameter, thickness. Propose a possible supporting principle.
 - d. Design of the supporting system. Choose type (column, tie rods, etc.), make a conceptual design (materials and sizing for mechanical and thermal requirements). Consider maximum loads from road transport: vertical: 7 m/s^2 ; lateral: 4 m/s^2 ; longitudinal: 6 m/s^2 and a minimum Safety Factor on 2 on $\sigma_{0.2}$.
 - e. Propose a possible assembly method of the cavities string inside the vacuum vessel

2. Calculate the static thermal performance (Heat Loads) and total cooling mass flow needs, for the following :
 - a. Supporting system (no heat intercept)
 - b. RF couplers (with active vapor cooling or not)
 - c. Beam tubes cold to warm transitions (cones between 300 K and 4.2 K, no heat intercept). (neglect conduction path of bellows)
 - d. Thermal radiation from vacuum vessel and thermal shielding (flat plate approximation). Calculate the radiation load in the absence of a thermal shield.
 - e. Calculate liquid boil-off mass flows, liquefaction load for ideal vapor cooling of couplers, and thermal shield mass flow assuming $T_{\text{in}}=50 \text{ K}$ and $T_{\text{out}}= 55 \text{ K}$.

Task 1.1. Table of design parameters

Item	Description	Value	Comments
1 a.			
1 b.			
1 c.			
1 d.			
1 e.			

Task 1.2. Table of Static Heat Loads and mass flows

Source of HL	HL (W) @ 4.2 K		HL (W) @ 50 K	4.2 K liquid boil-off (g/s)	Liquefaction load (g/s)	Thermal shield mass flow (g/s) (with $T_{in}=50K$, $T_{out}=55 K$)
Supports conduction			-		-	-
Beam tube cones conduction			-		-	-
RF Couplers conduction (uncooled)		-	-		-	-
RF Couplers conduction (ideal vapor cooling)	-					
Radiation, with thermal shield @ 50 K					-	
Radiation, without thermal shield			-		-	-
Radiation from beam tube cones			-		-	-
Totals						

Task 2. Cool-Down

The cool down from 293 K is obtained by boil-off of liquid helium at 4.2 K (1 bar) entered from the bottom of the helium vessels.

- a. Calculate the liquid helium need (mass in kg) for cooling down to 4.2 K helium the mass of cavity+helium tank. Consider, during the CD process, an average effectiveness in the use of the sensible heat of helium vapor between 4.2 K and 100 K (exhaust temperature at the exit of the cavity). How correct is this assumption? (Neglect, in the calculation, the contribution from static heat loads to the power balance).
- b. Calculate the average cooling power for a cool down from 293 K to 100 K in 12 h, assuming that cavity/helium vessel are isothermal in the cooling process

Task 2 Results

Item	Value	Comments
a.		
b.		

Task 3. RF operation, helium boil-off and pumping

During RF operation of a cryomodule, a dynamic heat load 175 W is added to the static heat load calculated previously. Vapours are pumped back to the refrigerator through a 1'000 m long, DN200 smooth pipe, routed in a shielded and vacuum insulated transfer line.

- a. Calculate the total boil-off rate in saturated helium at 4.2 K and 1 bar (g/s) for one cryomodule
- b. Calculate the pumping pressure drop along the line, neglecting static heat loads along the line
- c. Calculate the total pressure drop for 35 cryomodules all operating with the same dynamic load
- d. If the cavities operate at 2K, 30 mbar, calculate the pressure drop along the line

Task 3 Results

Item	Value	Comments
a.		
b.		
c.		
d.		