

# The Forward Liquid Argon Experiment at the Forward Physics Facility for High Energy Neutrino and Dark Matter Searches at LHC

*Jianming Bian (University of California, Irvine)*

*Milind Diwan (Brookhaven National Lab)*

*Jonathan Feng (University of California, Irvine)*

*NuFACT2023, Seoul, Korea, 2023 August 25*

# Forward Physics Facility (FPF) and FLArE

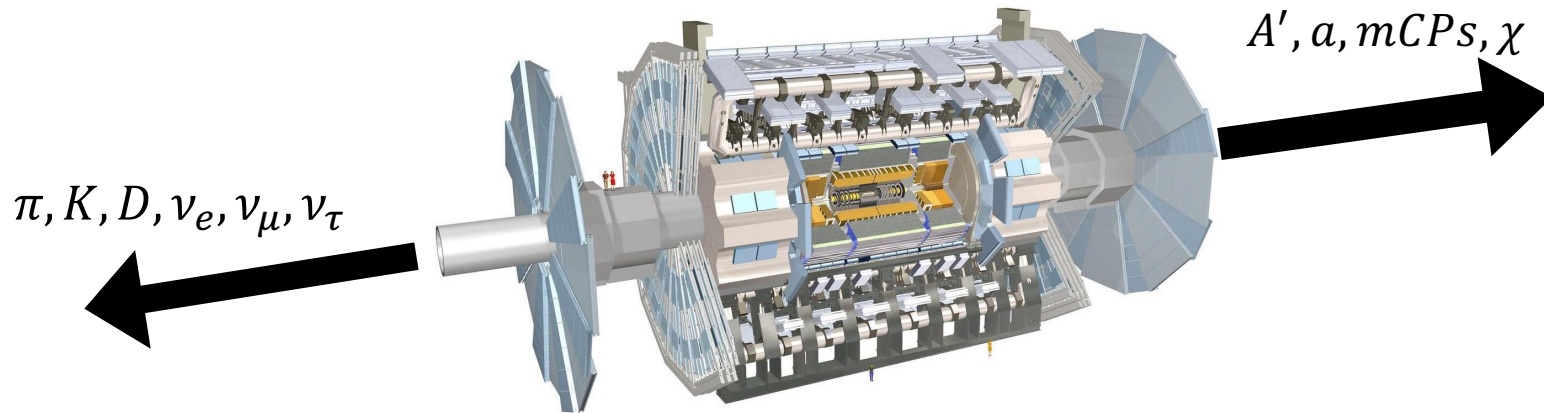

- Most interesting physics is believed to be at high  $p_T$ , and so are we missing physics in the forward direction?
- The largest flux of high energy light particles, pions, kaons, D-mesons, and neutrinos of all flavors is in the forward direction.
- This could be true of new particles also: dark photons, axion-like particles, millicharged particles, light dark matter, etc.
- The high laboratory energies ( $>100$  GeV), and kinematically focused nature of the particles presents a unique opportunity that should not be missed with the high-luminosity LHC.



# Forward Physics Facility (FPF)



## and FLArE

- FPF: Proposal to create forward underground space for experiments during HL-LHC.
- FLArE: a liquid argon time projection chamber (LArTPC) detector for FPF to detect very high-energy neutrinos and search for dark matter at LHC@CERN
- The central goal of FPF is to extend the current LHC forward physics programs into the HL-LHC era with x10-100 exposure

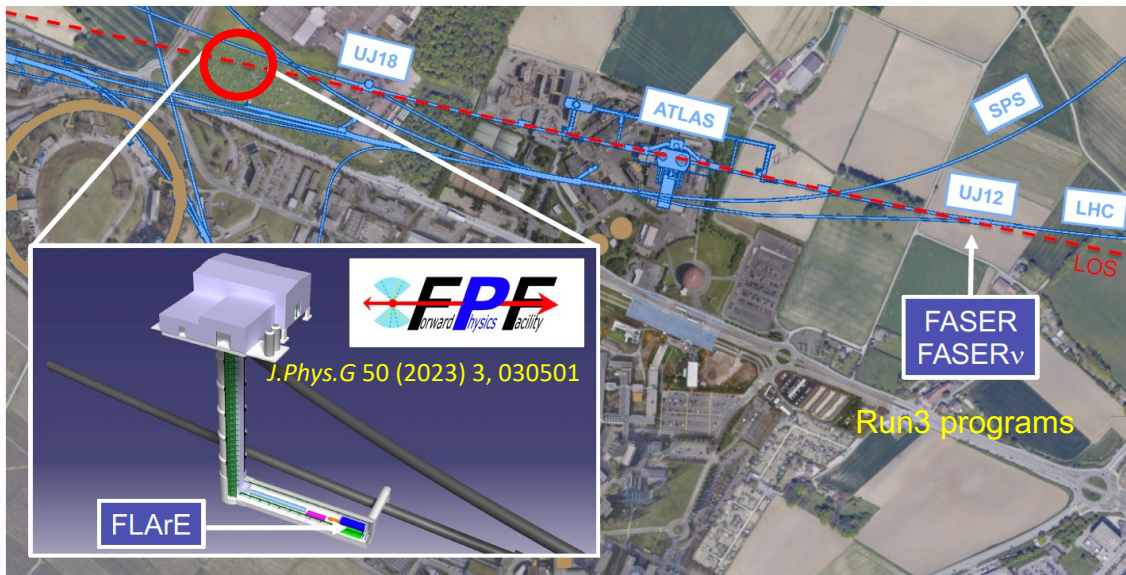

FPF: General purpose facility with broad SM and BSM program; spans all HEP frontiers.

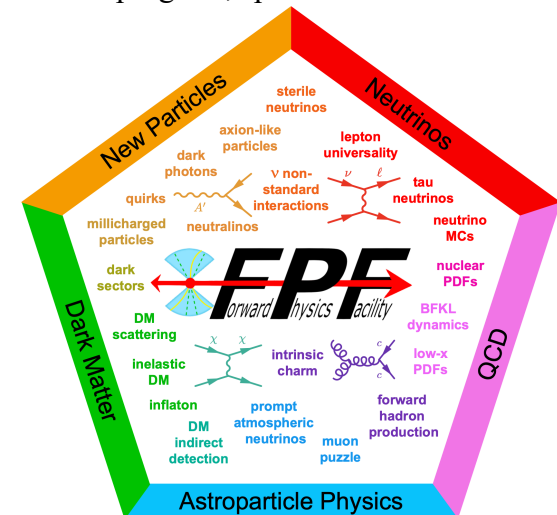

The FPF will be located 620-680 m west of the ATLAS IP along the line of sight (LOS). Also shown is the location of FASER and FASERv, which are also located along the LOS, but 480 m east of the ATLAS IP

# Current forward physics program with LHC Run 3

- 4 experiments in progress for LHC-run3 for  $150\text{fb}^{-1}$  2022-24.
- FASER (March 2019), Magnetic spectrometer for neutral decays.
- FASERnu (Dec 2019), Emulsion/tungsten detector ( $\sim 1$  ton)
- SND@LHC (Mar. 2021) Hybrid electronic and tungsten/emulsion detector. ( $\sim 1$  ton)
- Also MilliQan located near CMS (not forward); scintillation bars to see milli-charged particles.
- This program will provide excellent experience for the FPF.

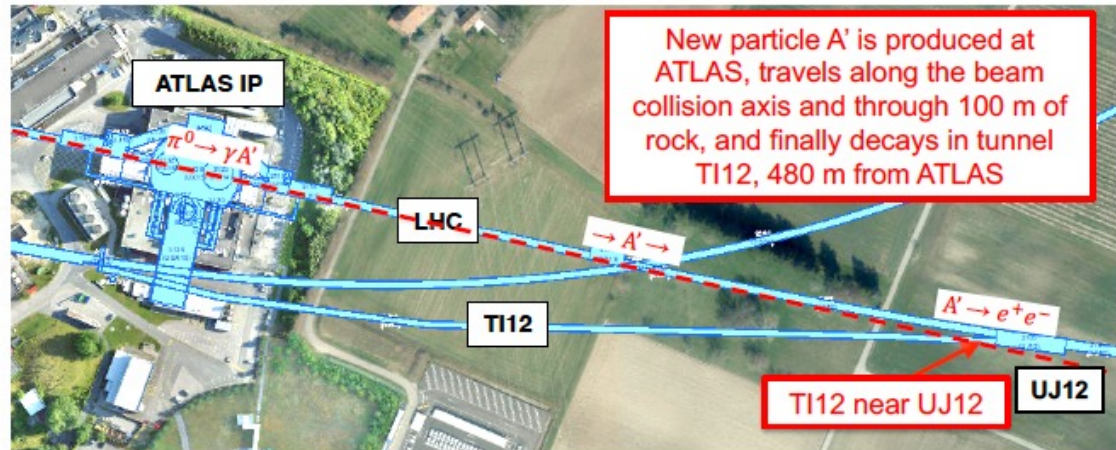



# FASER results

- 2018 pilot emulsion detector with 11 kg was deployed for 12.2 fb-1
- May 2021, first collider neutrinos detected at 2.7 sigma, announced 6 candidates with 12 backgrounds.
- Measured muon rate at that location
- Muon and neutrino rates in rough agreement with expectations
- First observation in 2023 based on 35.4 fb-1, 153 neutrino interactions with a significance of 16 sigma
- New NuE results see Tomoko Ariga's plenary talk at NuFACT

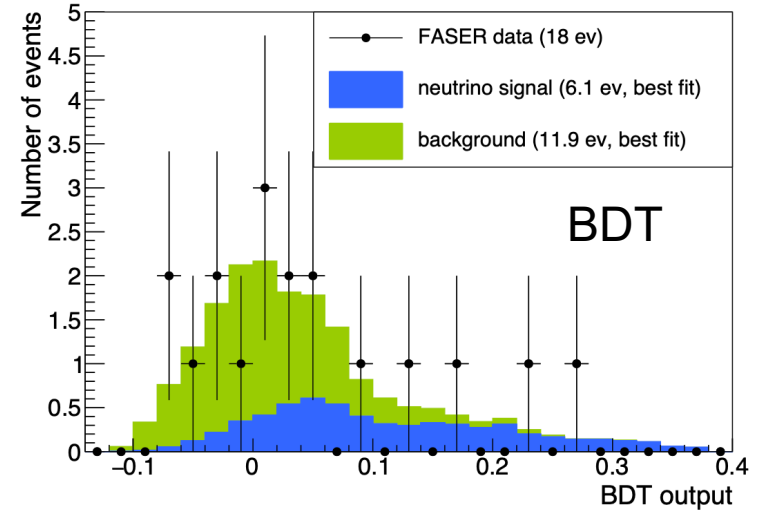

*Phys.Rev.D* 104 (2021) 9, L091101

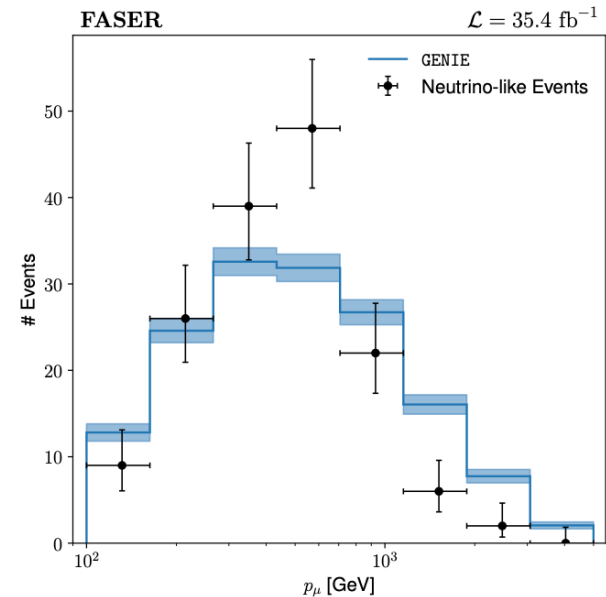
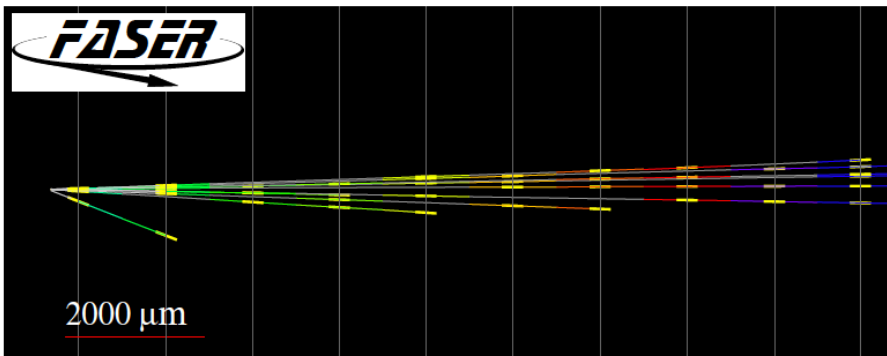
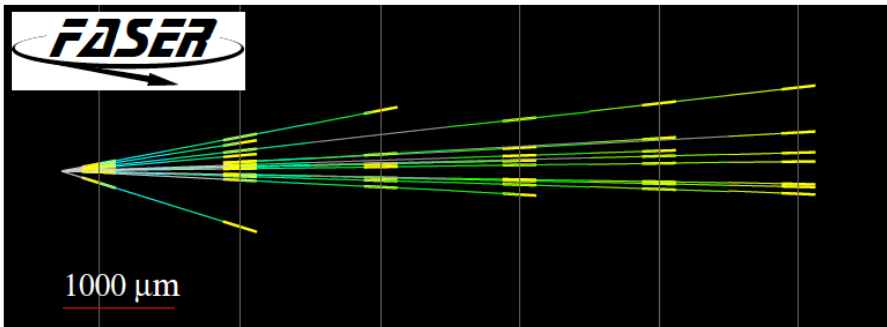

*Phys.Rev.Lett.* 131 (2023) 3, 031801

# FPF Physics Goals

## Neutrino physics

- Measure the flux of tau neutrinos
- Limit the oscillations of tau neutrinos into other neutrinos over the parameter range defined by the energy spectrum and distance
- Determine the cross section of neutrino interactions in the energy range of hundreds of GeV to few TeV
- QCD physics with far forward neutrinos

## Dark matter search sector

- Detection of dark photon and other dark sector particle decays in the detector volume
- Detection of light dark matter scattering in detector
- Search for milli-charged dark matter particles
- Search for dark tridents

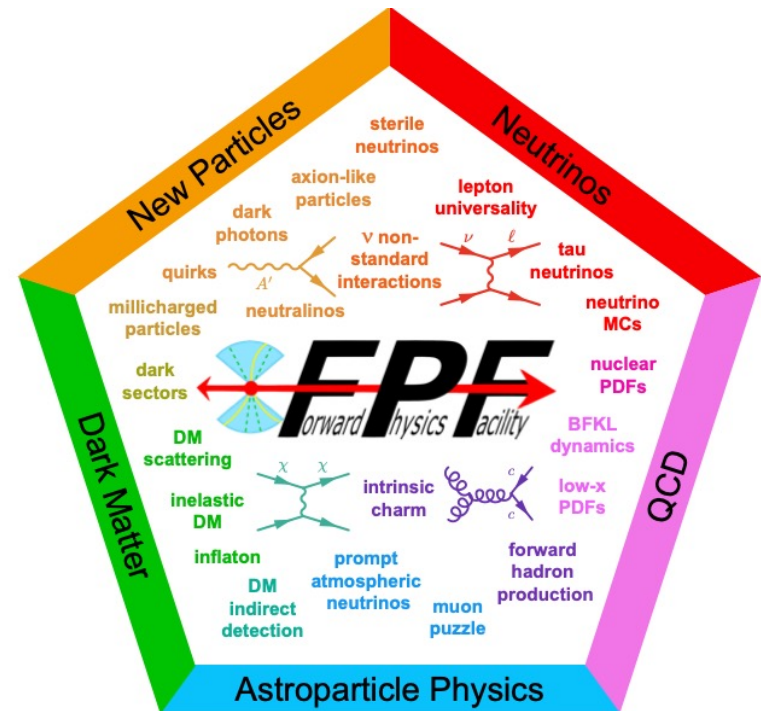



# Proposed Detectors for FPF

Experiment	Science Priority	Technology
<b>Faser 2</b>	Long-live neutral particles decay	Large decay volume (super-conducting) magnetic spectrometer
<b>FASERnu2</b>	Neutrino Interactions	Tungsten/Emulsion 20 tons. Veto and interface tracker for muons
<b>AdvSND</b>	Neutrino Interactions on/off axis	Electronic fine grained detector with a magnetic muon spectrometer
<b>FORMOSA</b>	Milicharged particles	Scintillation bars with photomultiplier readout.
<b>FLArE</b>	DM scattering and neutrino interactions	Liquid Argon TPC 10-20 tons

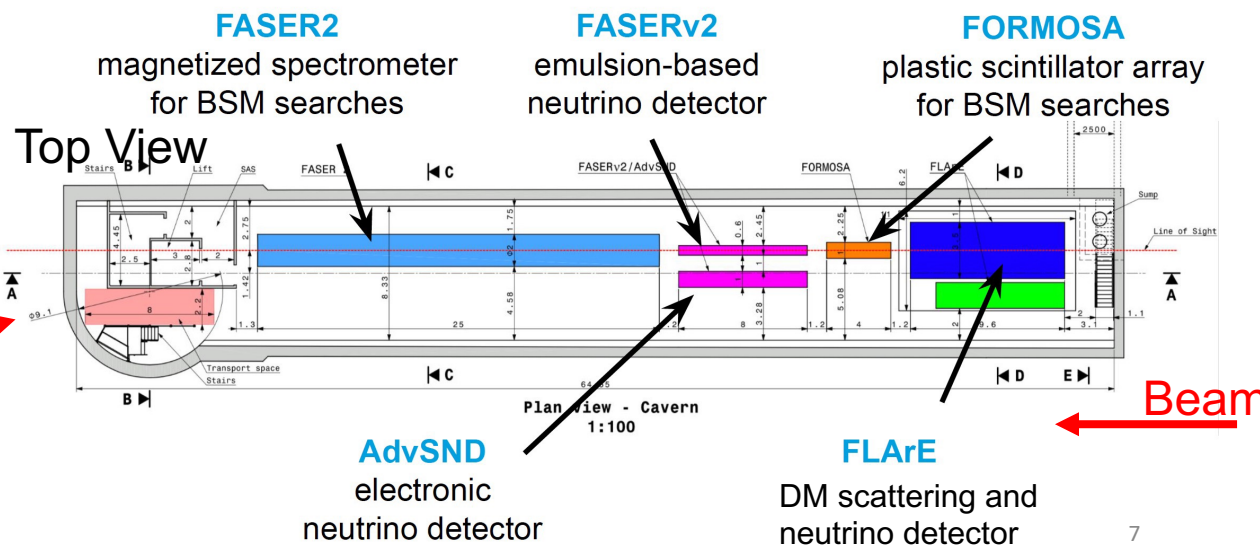
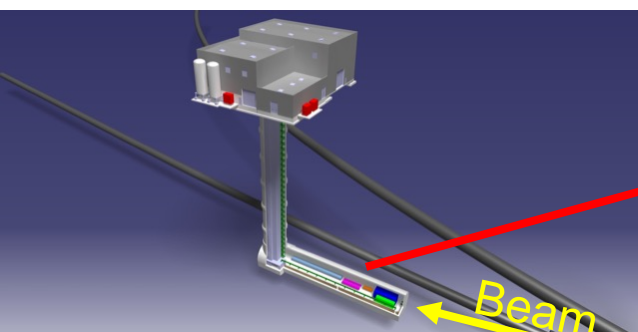

# FPF Cavern and Shaft

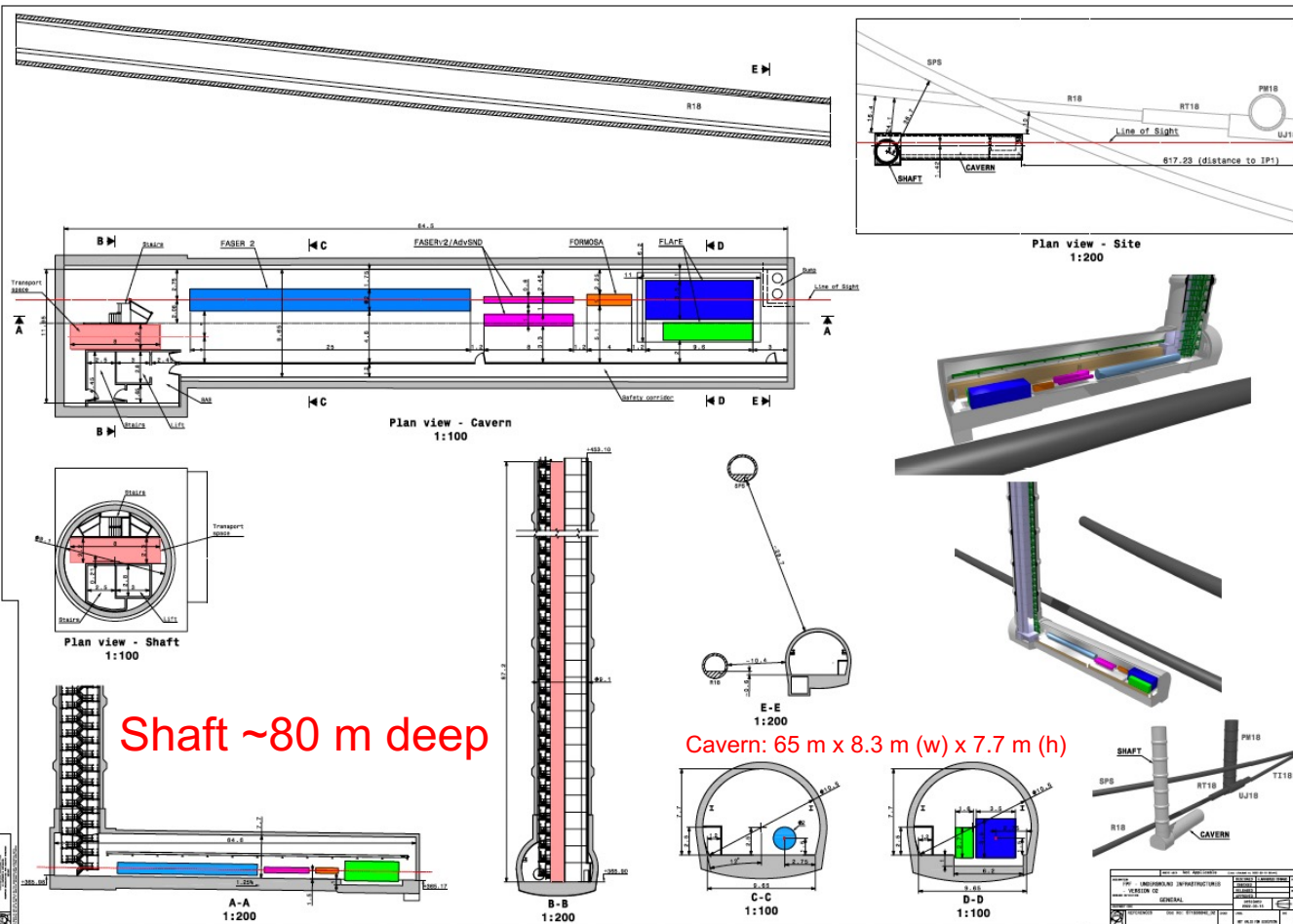

- Preliminary numbers, but the constraints are well known.
- The LOS might change over the course of the run by 17 cm. and so we have to allow for that.
- Paying particular attention to the liquid argon space. This needs to accommodate a cryostat and cryogenics.
- There will be a 20 ton crane
- The cost estimate as of now is 40 M CHF.



# Neutrino physics

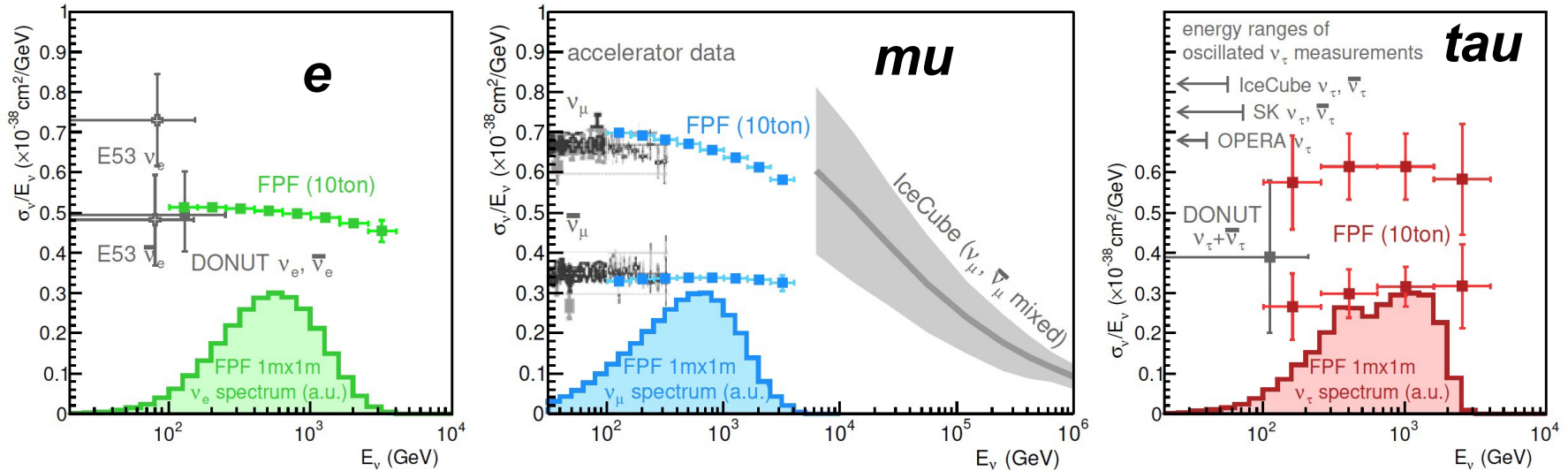

- The current data from accelerators ends around 300 GeV. FPF would provide data that fills in the gap between accelerators and atmospheric neutrinos.
- There are three proposed detectors at 10 ton each: FASER $\nu$ 2 (emulsion), SND(TBD), and FLArE.
- Total rate will be  $\sim 100$ k electron neutrinos,  $\sim 1$ M muon, and  $\sim$ few thousand tau neutrino events.

# Light Dark Matter scattering

## Elastic scattering from electrons or nuclei

- Mass of the  $\chi$  alters the kinematics of the outgoing electron or nucleus.
- Signal is at low energy ( $\sim 1$  GeV)
- Background is from neutrino interactions and muons.
- The sensitivity plot assumes reasonable cuts for background suppression
- Makes use of the huge flux of mesons for this *direct detection* technique to get to the relic density target.

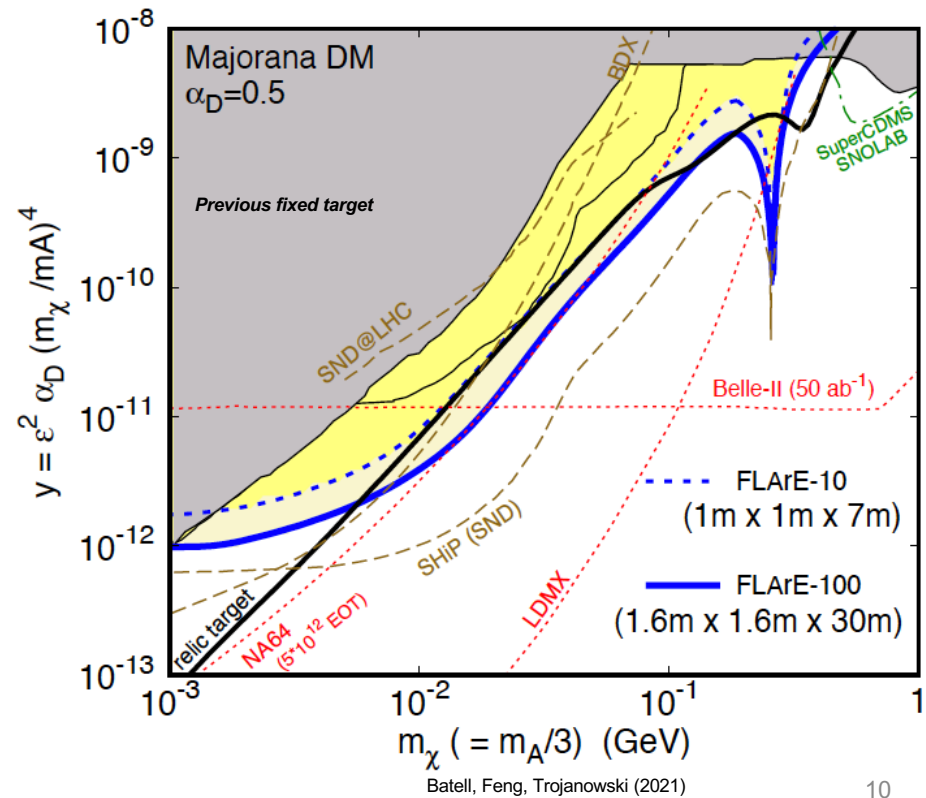
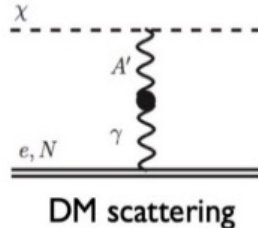
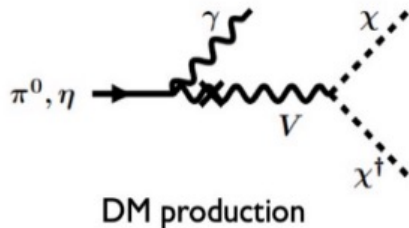



# Milicharged particles

- These emerge in models with massless dark photons which couple weakly to dark particles.
- The idea is to see them using  $dE/dx$  in a low noise detector.
- Deep bars of scintillator coupled to PMTs: milliQan (central location) and FORMOSA (at FPF)
- The FPF sensitivity assumes high efficiency light sensitivity in 1 meter bars of plastic scintillator with coincidence of 4.
- How can we do better ? Is it possible to use a liquid argon TPC with very good single electron sensitivity (with 2phase)

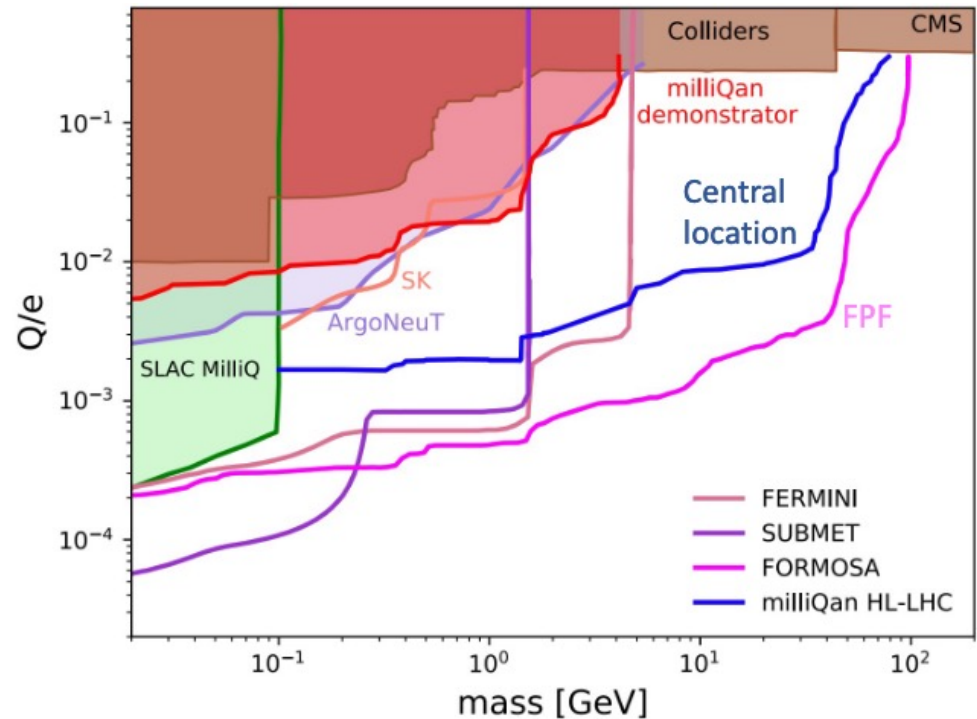

Foroughi-Abari, Kling, Tsai (2020)

# Cryostat options for FLArE

Very important for space considerations.

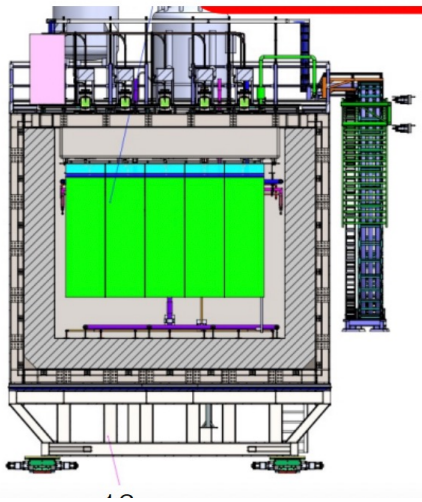

	Cryostat Inner Dimensions	Insulation Type	Insulation Thickness	Insulation density	Heat leak	Cold shield
MicroBooNE	3.8m dia x 12 m	Polyurethane Foam	400mm	32 kg/m <sup>3</sup>	~13 W/m <sup>2</sup>	No
ICARUS-GS	3.9m x 3.6m x 19.6m	Nomex honeycomb+perforated Al	665 mm+ (combined)	25-35 kg/m <sup>3</sup>	7-22 W/m <sup>2</sup>	Yes
ICARUS-SBN	3.9m x 3.6m x 19.6m	Al extrusion+GTT foam	665 mm+ (combined)	25-35 kg/m <sup>3</sup>	10-15 W/m <sup>2</sup>	Yes
ProtoDUNE	7.9m x 8.55m x 8.55 m	GTT membranc	800mm	90 kg/m <sup>3</sup>	~8 W/m <sup>2</sup>	No
ND-LAr	3m x 5m x7m	GTT membrane	800mm	90 kg/m <sup>3</sup>	~8 W/m <sup>2</sup>	No
FLArE	~(1m x 1m x 7m)					No?

Yichen Li

- Space in FPF hall currently is limited to 3.5 m X 3.5 m X 9.6 m for FLArE.
- 80 cm GTT membrane occupies 1.6 m out of 3.5 m. More space might be needed for corrugations.
- GTT is easy to install, DUNE ND-LAr design has installation from top, this would also simplify things.
- Further Engineering will be needed, but we can settle on GTT membrane for now.

# FLArE Detector

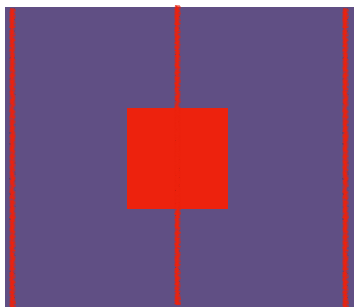

Simulations have confirmed that these dimensions allow reasonable containment of neutrino events in LAr and total energy measurement.

They also fit within the cryostat allowed transverse space.

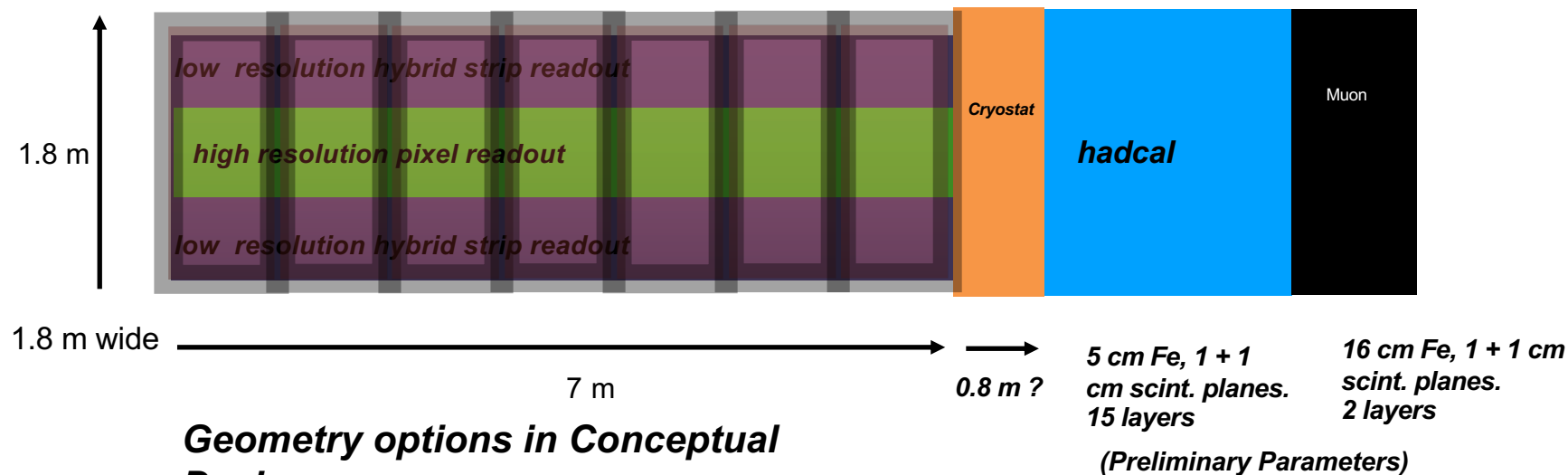

## Geometry options in Conceptual Design:

- 2 X 7 vertical modules
- 3 X 7 vertical modules
- 0.45 m or 0.3 m gap

Option to use combined high / low resolution TPCs

# FLArE Detector

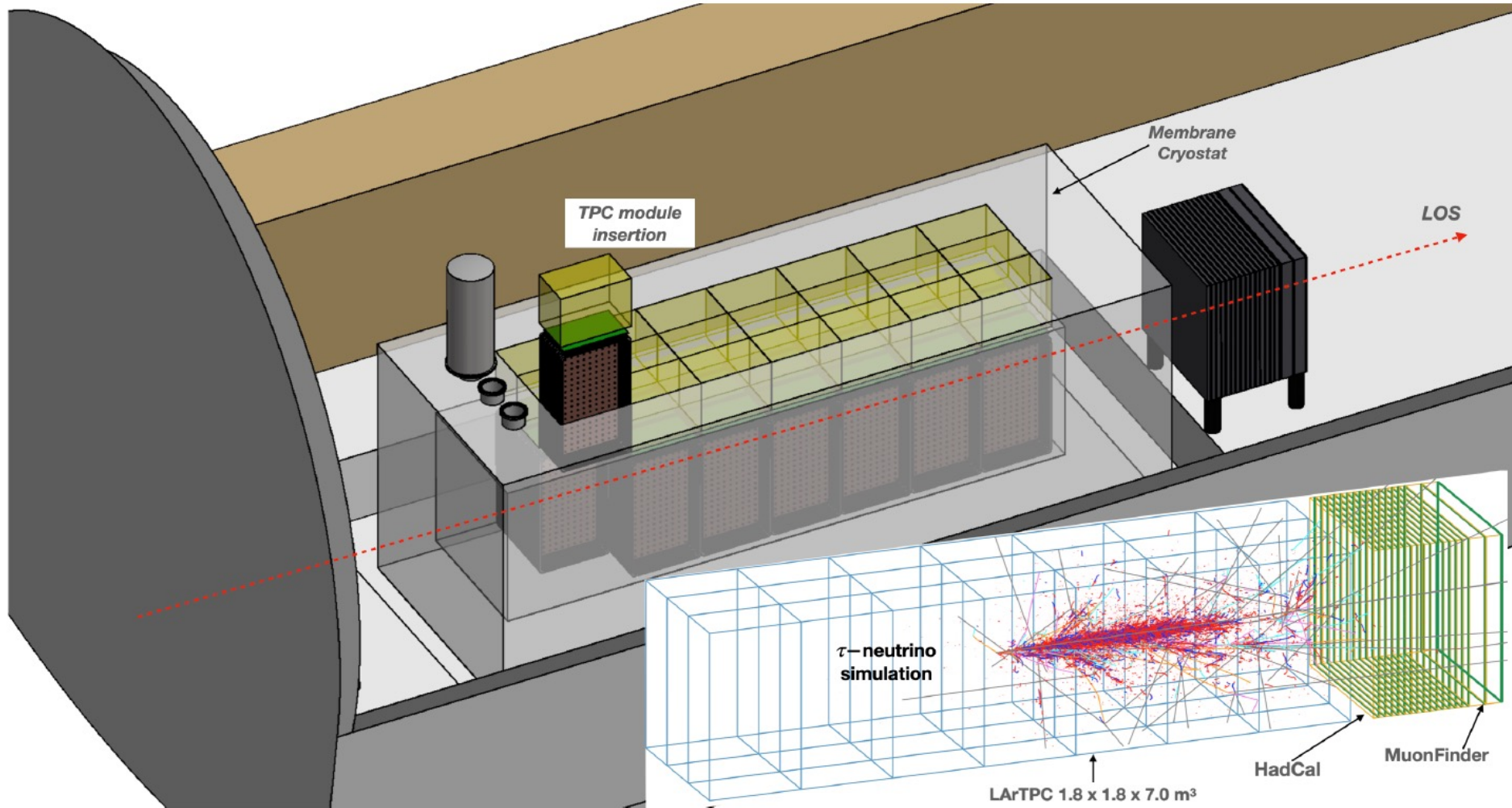



# Benefit from the DUNE near detector design

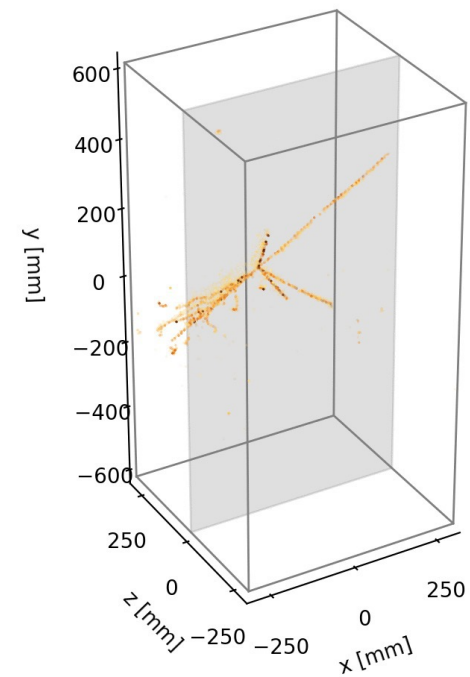

# Hardware-based trigger studies

- FLArE trigger system will need to identify signal events from muon background.
  - 0.5 Hz/cm<sup>2</sup> muon flux from ATLAS collisions gives 5 kHz rate in the 1m x 1m x 7m fiducial region
- Want to match signal events to ATLAS bunch crossings
  - Need fast trigger decisions to meet HL-LHC ATLAS 6  $\mu$ s (30  $\mu$ s) L0 (L1) trigger latency requirements
- Will try combination of traditional/ML methods for SiPM/event-level trigger decisions on GPU/FPGA.

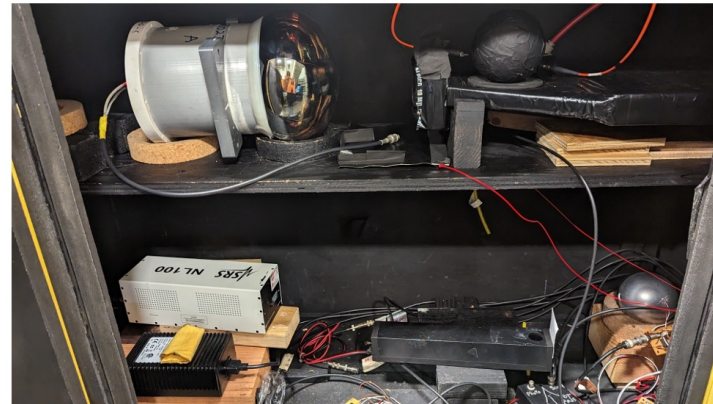
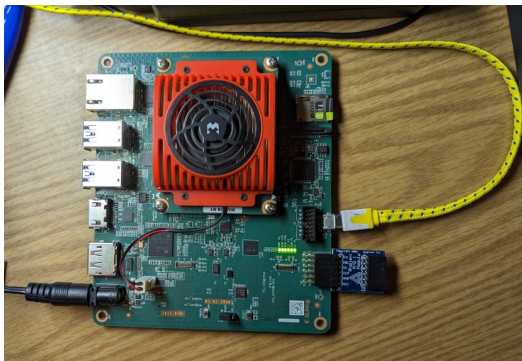

Xilinx Kria KV260 FPGA development board to GPU group server

- Teststand: Nitrogen laser and 1" PMT/SiPM in a dark box for realistic signal and dark noise pulses.

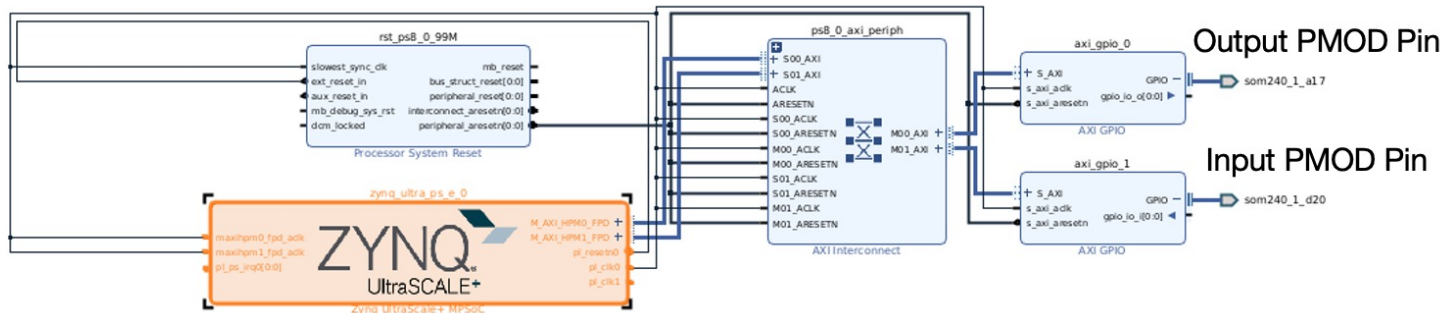

# Experimental conditions (without sweeping magnet, very preliminary, work in progress)

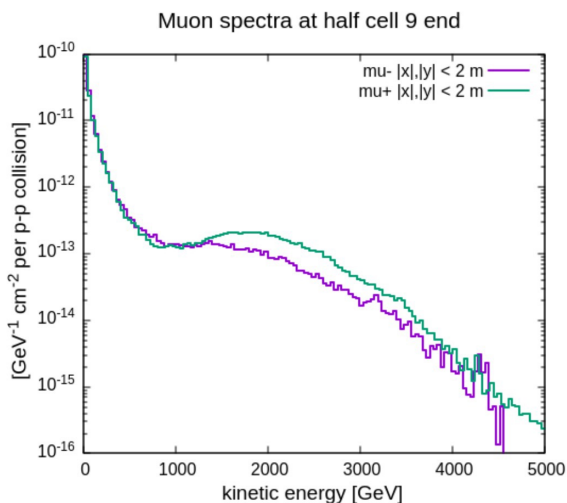

Approximate muon fluxes, rates of backgrounds

Minimum distance	612 m
Total Lumi/max lumi	3000/fb ; $5 \times 10^{34}$ /cm <sup>2</sup> /sec
Lumi per day	~1 /fb assuming 10 year running
pseudorapidity coverage	>6.4, (~5.4-6.0 for off-axis)
Mu+/Mu- flux > 10 (100) GeV	1.5/0.93 (0.94/0.39) $10^4$ /cm <sup>2</sup> /fb <sup>-1</sup>
track density (from data)	$1.7 \times 10^4$ /cm <sup>2</sup> /fb <sup>-1</sup>
max track density per sec (per crossing)	0.85/cm <sup>2</sup> /sec ( $2 \times 10^{-8}$ /cm <sup>2</sup> /crossing)
Tracks in detector/1 ms	$8.5/m^2/1msec$
Neutral hadron flux > 10 GeV ( $10^{-4}$ of muons)	~3 /cm <sup>2</sup> /fb <sup>-1</sup>
Total neutrino rate (all flavors)	~50/ton/fb <sup>-1</sup>

- This rate will be lower at 612 m.
- Both charged and neutral hadron interactions present significant background.
- Total neutrino interaction rate normalized to per ton per fb<sup>-1</sup>
- Observed nu rate: ~45/ton/fb-1 at 480 m

arxiv 2105.06197

# Muon momentum measurement

- Muons can easily pass through the detector, with a small portion of the energy deposited in the detector
- Propose to cooperate with FASER2's magnet, along with the magnetized HadCal and MuonFinder, in order to precisely reconstruct the muon momentum

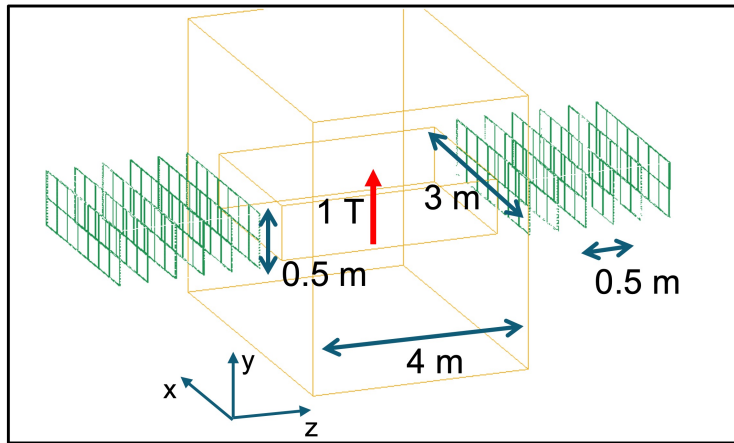

Rectangular window: 3 m x 0.5 m (4 Tm)  
 6 tracking stations, 50 cm apart  
 B = 1 T (fixed)

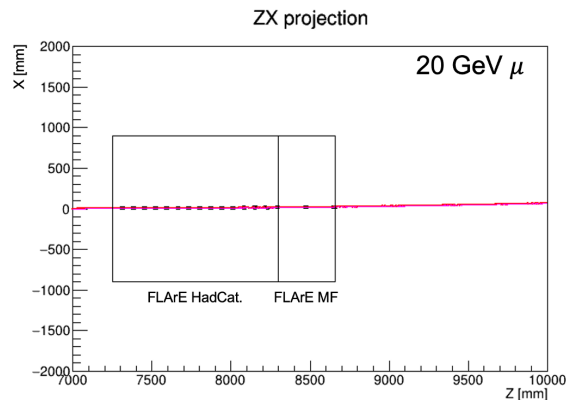

Complete geometry in the simulation:

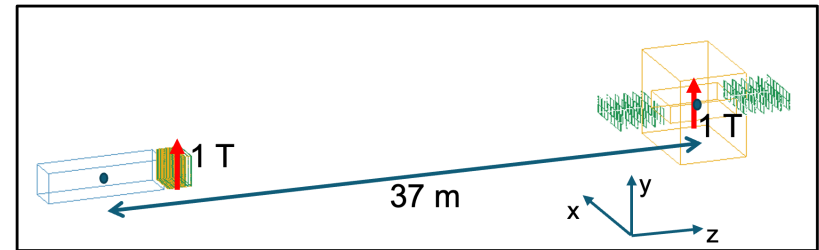

FLArE center to magnet center: 36.9 m  
 Magnetized HadCatcher and MuonFinder  
 B = 1 T (default, but still open to optimization)

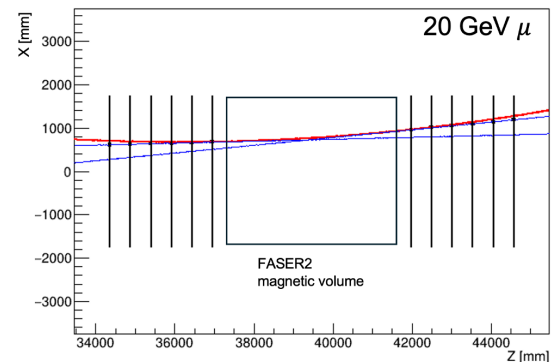
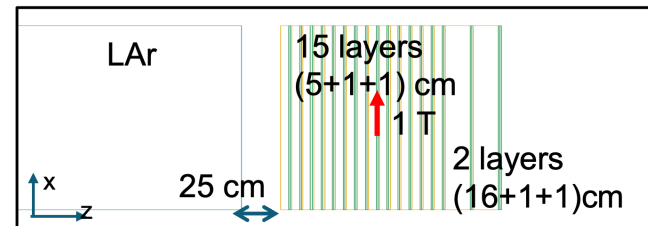



# Event simulation in FLArE

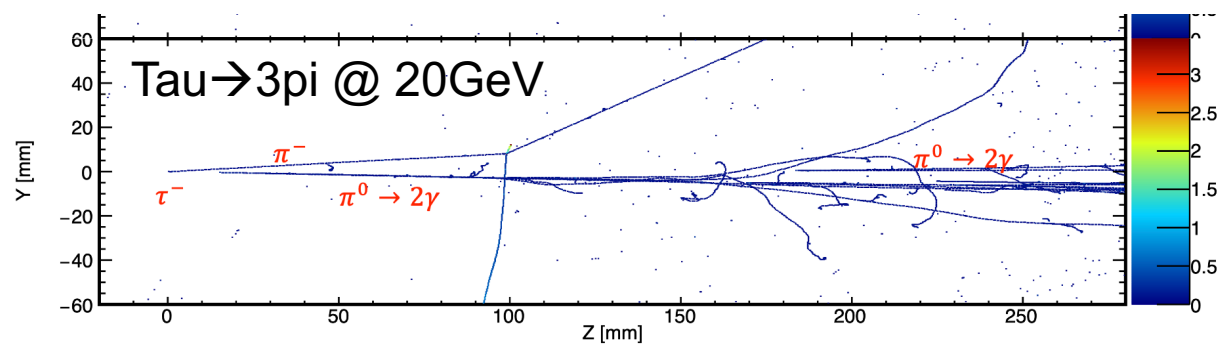
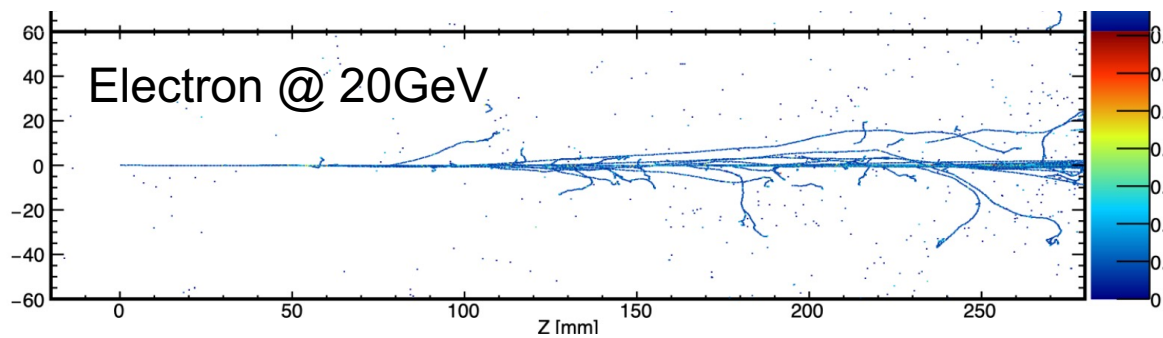
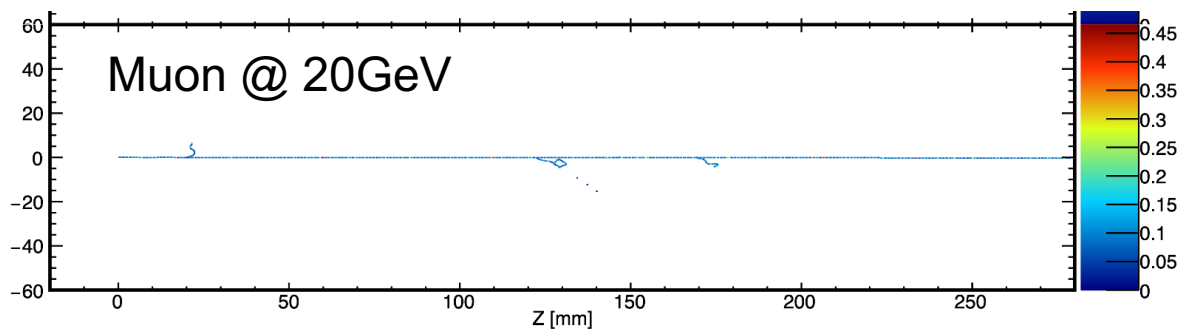

$\nu_\tau$  CC ( $E_\nu = 230.7$  GeV)

$\tau^-(102.9 \text{ GeV}) \rightarrow \nu_\tau + \bar{\nu}_\mu + \mu^-(74.7 \text{ GeV})$

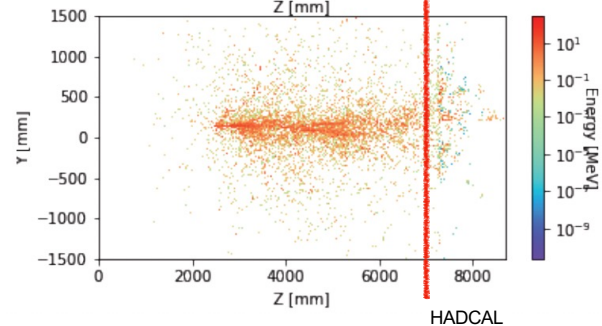
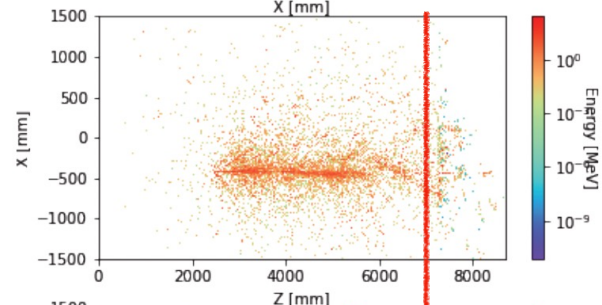
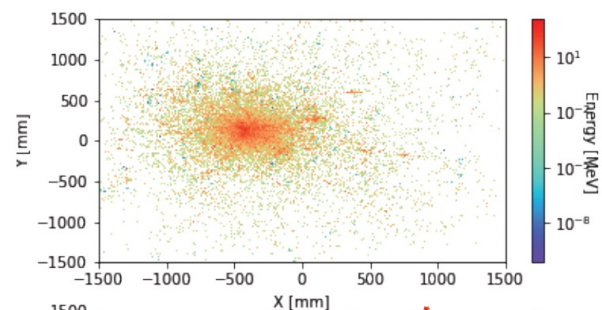

# Reconstruction and Event Identification

$\nu_\tau$  CC,  $\tau \rightarrow \mu$  and  $\nu_\mu$  CC are distinct from other channels in  $dE/dx$  and energy deposit

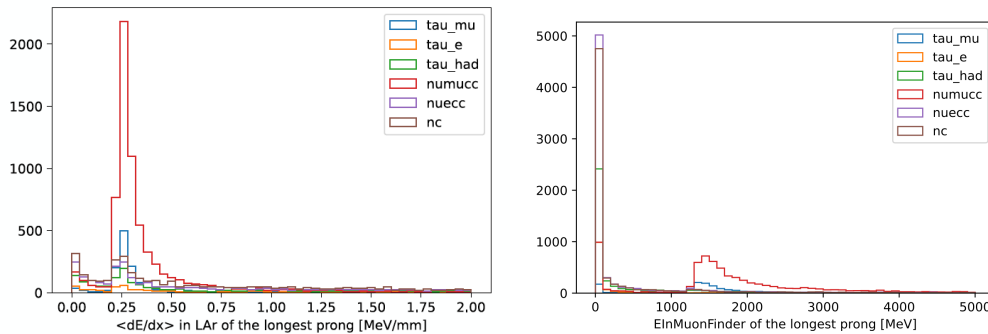

Singe Particle BDT

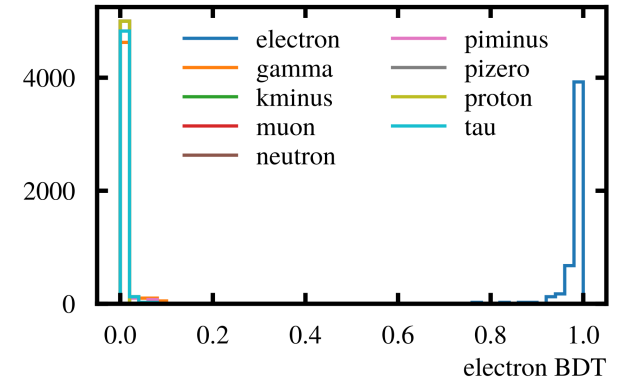

$\nu_\tau$  CC,  $\tau \rightarrow \mu$  have more neutrinos in the final state than  $\nu_\mu$  CC, thus more missing momentum in the transverse plane

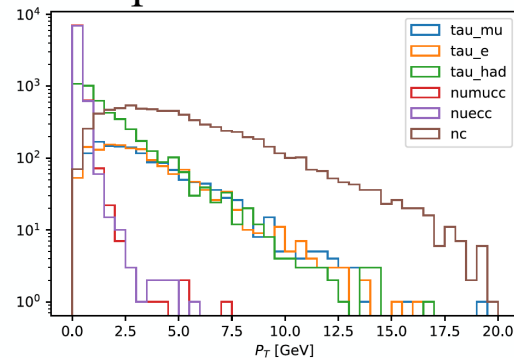
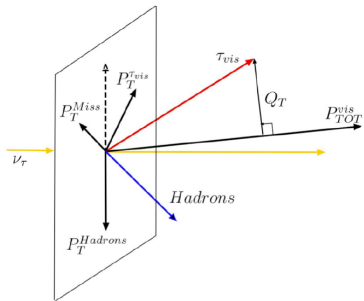

A BDT shows promising results to select  $\nu_\tau$  CC,  $\tau \rightarrow \mu$  from backgrounds, working on other  $\tau$  decay modes

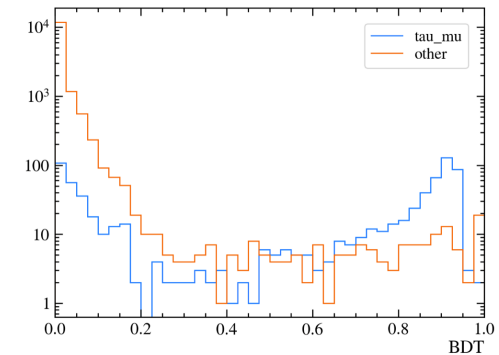

Working on physics sensitivity

## Preliminary (optimistic) schedule of HL-LHC

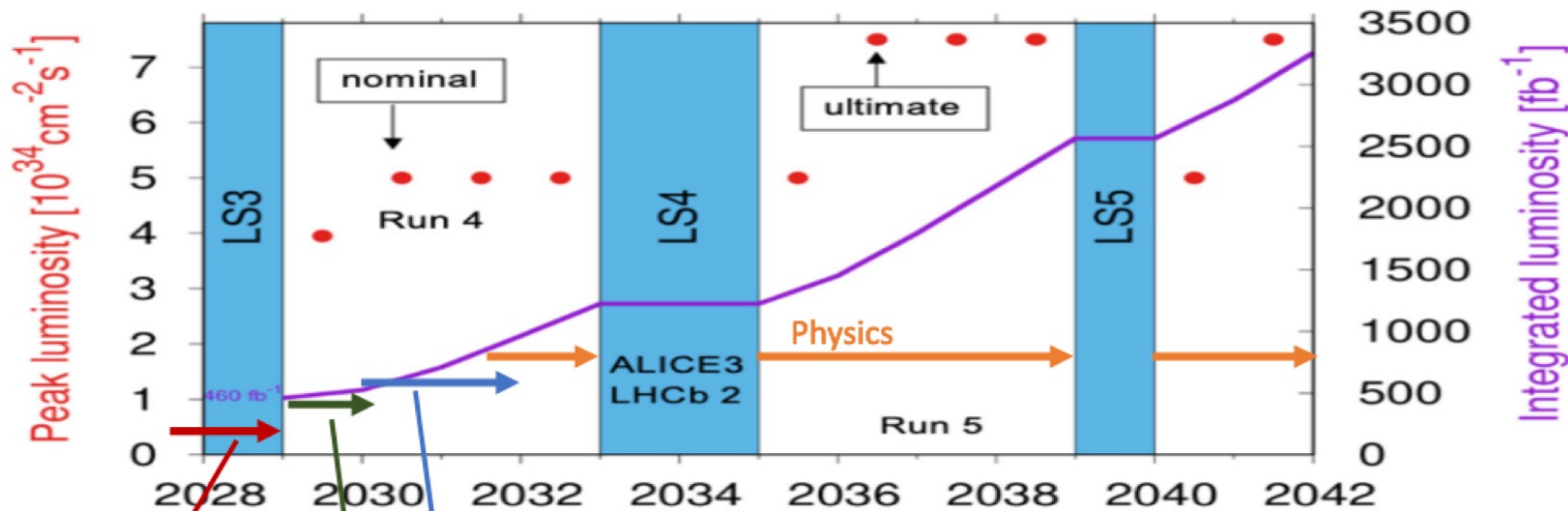

### Pure CE works

The FPF cavern is not connected to the LHC and no impact on HL-LHC running is foreseen.

Installation and commissioning of the experiments

Installation of services (CERN technical teams, busy during LS3)

### Such a schedule would:

- Allow physics data taking for most of the luminosity of the HL-LHC
- Not overload CERN technical teams during LS3
- Design of facility would allow different experiments to come online at different times

### Requirements:

- Can access the facility during LHC operations (RP study ongoing)
- Can complete CE works before the end of LS3

Construction independent to HL-LHC project  
Reviews underway, schedule subject to change

# Summary

- A forward physics facility FPF is being considered at CERN for neutrino and dark matter physics.
- The physics interest is
  - Neutrino cross sections in the 1 TeV range:  $\sim 20-50$  events/ton/day
  - Tau neutrino flux and associated heavy flavor physics:  $\sim 0.1-0.2$  events/ton/day
  - Light dark matter search with decays and interactions.
- Liquid Argon detector FLArE for FPF is being considered
- Detector capability, event rate and backgrounds of FLArE are preliminarily studied, showing that a LAr detector is feasible and groundbreaking
- Engineering and simulation work towards a CDR is underway

감사합니다

*Thank you!*



# Backup

# Sweeper Magnet: Ongoing Studies

- Preliminary design of sweeper magnet by TE-MSC
  - Based on permanent magnet to avoid power converter in radiation area
  - Consider 7m long ( $20 \times 20 \text{cm}^2$  in transverse plane) magnet, 7Tm bending power
- To install such a magnet would require some modifications to cryogenic lines in relevant area
  - Possibility of modifications to be investigated with LHC cryo
  - Integration/installation aspects to be studied
- FLUKA and BDSIM studies ongoing to assess effectiveness of such a magnet in reducing the muon background in the FPF

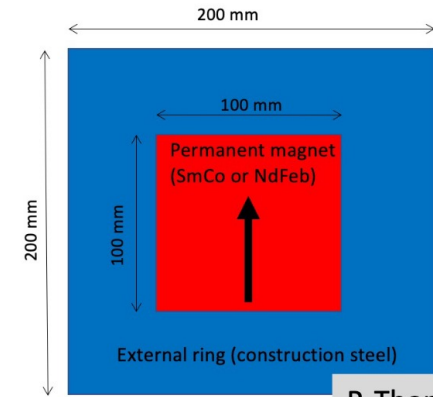

P. Thonet (TE-MSC)

Consider to add a sweeper magnet upstream of the FPF (e.g. where the LOS leaves the LHC beampipe) to deflect muons from the on-axis neutrino detectors.

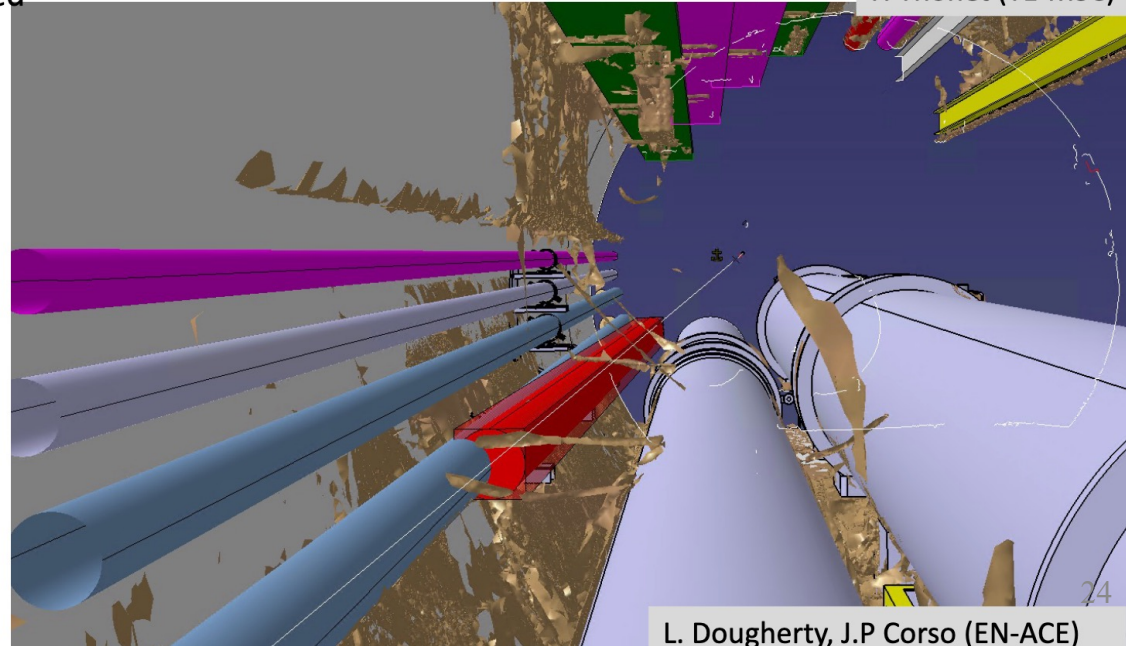

L. Dougherty, J.P Corso (EN-ACE)