

Singe Photon Imaging – From X-rays to Visible Light

Rolf Kaufmann

CSEM Zurich

Technoparkstrasse 1

8005 Zurich

Switzerland

rolf.kaufmann@csem.ch

Inspired by Particle Physics



- Single particle detection is necessary
- Pulse counting circuits are the normal way to do this in semiconductor detectors
- Vast experience with different circuit architectures

Different Situation for Visible Light Imaging

- Photons have 1 – 3 eV energy
- Only 1 electron-hole pair per photon
- For single photon counting, noise would have to be below 1 electron
- The “holy grail” of image sensing



But First Back to X-rays

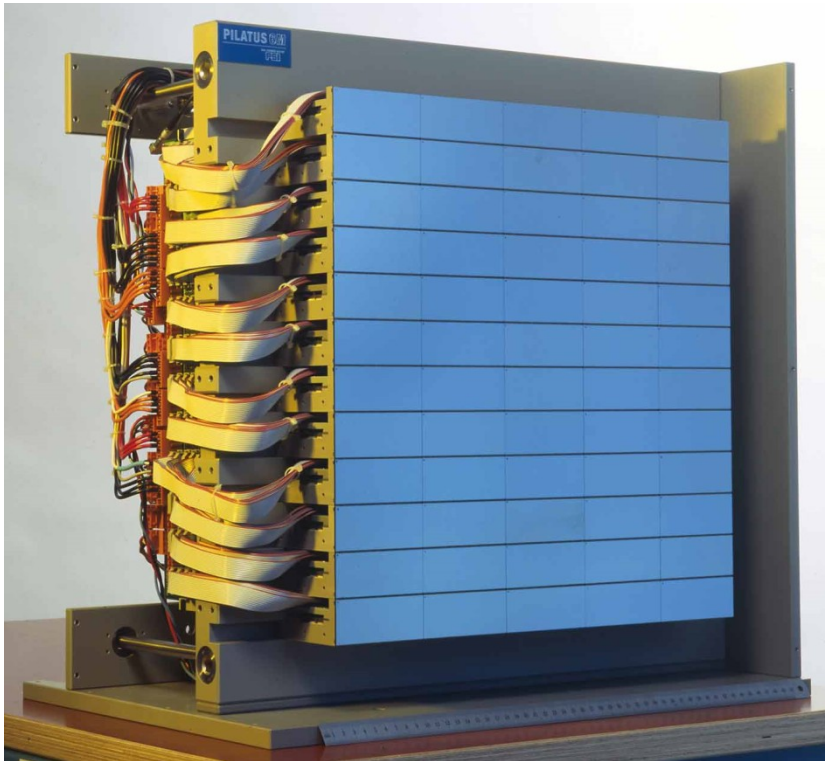

- Photon counting already established
- Medipix,
- Already commercial products available
e.g. from
 - Dectris
 - Sectra
 - PANalytical

Noise Challenge of Single-Photon X-Ray Sensing

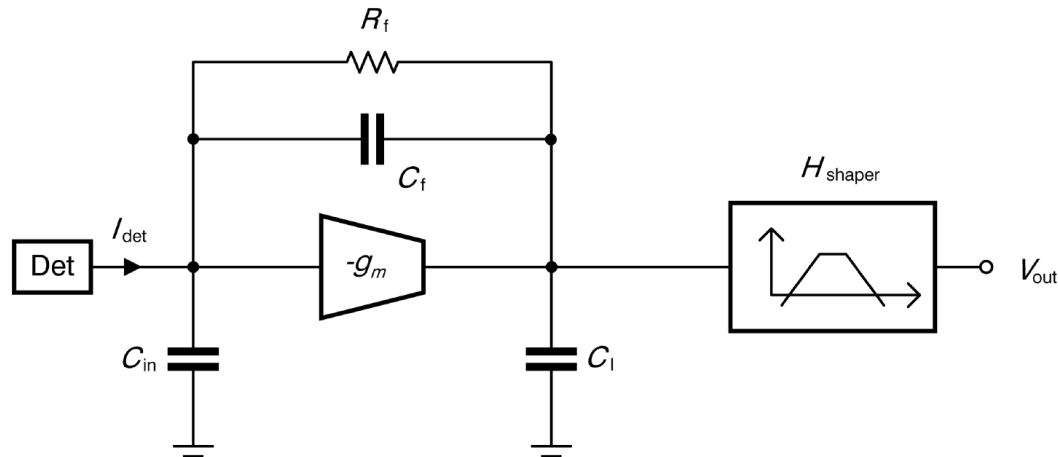

- Classical charge amplifier / shaper architecture
- Shaper works as a band-pass filter
- Noise contributions:

Feedback resistor

$$q_{ENC} \propto \sqrt{\frac{1}{R_f}}$$

Amplifier

$$q_{ENC} \propto (C_f + C_{in}) \sqrt{\frac{1}{g_m}}$$

C. Lotto:
Synchronous and asynchronous detection of ultra-low light levels using CMOS compatible semiconductor technologies

PhD Thesis (2010)
University of Neuchâtel

Improved Band-Pass Filter

- High feed-back resistor R_r
- Low capacitances C_{in} and C_f
- Resistor implementations: MOS transistors in weak inversion
- Resistance approx. constant since no amplification between S/D
- Amplifier as a source follower (no Miller effect)

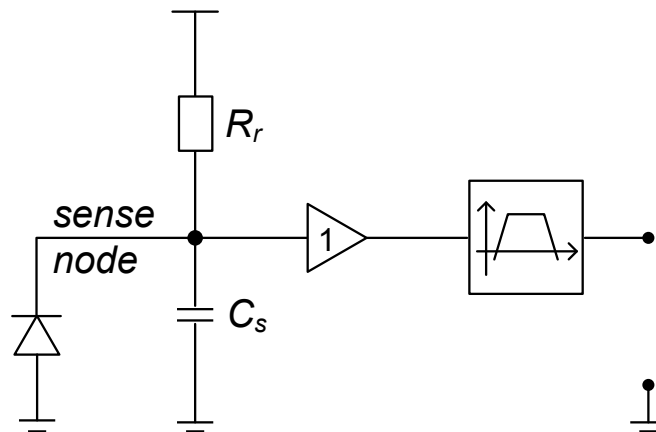

Transistor Level Circuit

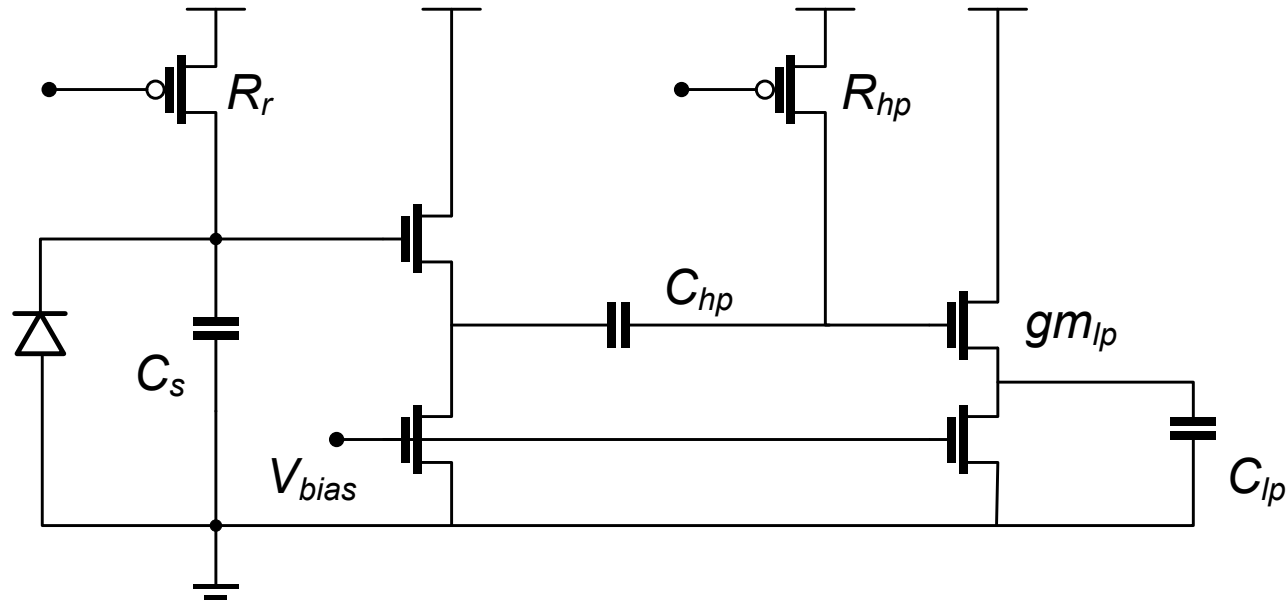

Feedback resistor

$$q_{ENC} \propto \sqrt{\frac{1}{R_r}}$$

Amplifier

$$q_{ENC} \propto C_s \sqrt{\frac{1}{C_{hp} \text{ and } C_{lp}}}$$

Low-Noise Pulse-Detection Pixel Design Parameters

Parameter	#1: Short Pulses	#2: Long Pulses
Detected pulse width	1.5 ns – 10 ns	150 ns – 1.5 μs
Conversion factor	12.5uV/e ⁻	27μV/e ⁻
Recharge time constant	50 ns	10 μs
High-pass filter time constant	12 ns	2 μs
Pixel area	30 μm x 22 μm	30 μm x 20 μm
Fill factor	51 %	56 %
High-pass filtering capacitance	115 fF	200 fF

Noise Comparison Circuit Only (Simulation)

Circuit Component	ENC contribution
Buffer	1.6 e
High pass filter	3.9 e
Low pass filter	1.4 e
Reset resistor	12.7 e
TOTAL	13.5 e

Photogate-Pixel to Reduce Sense-Node Capacitance

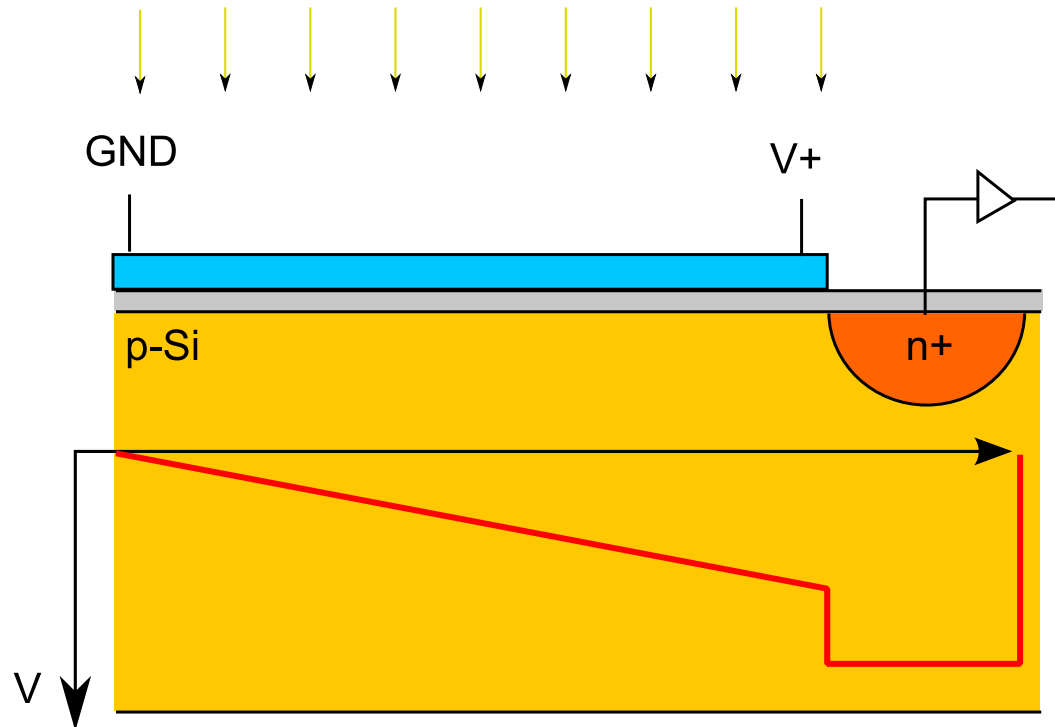

Layout Example

Photogate with a small Sense node

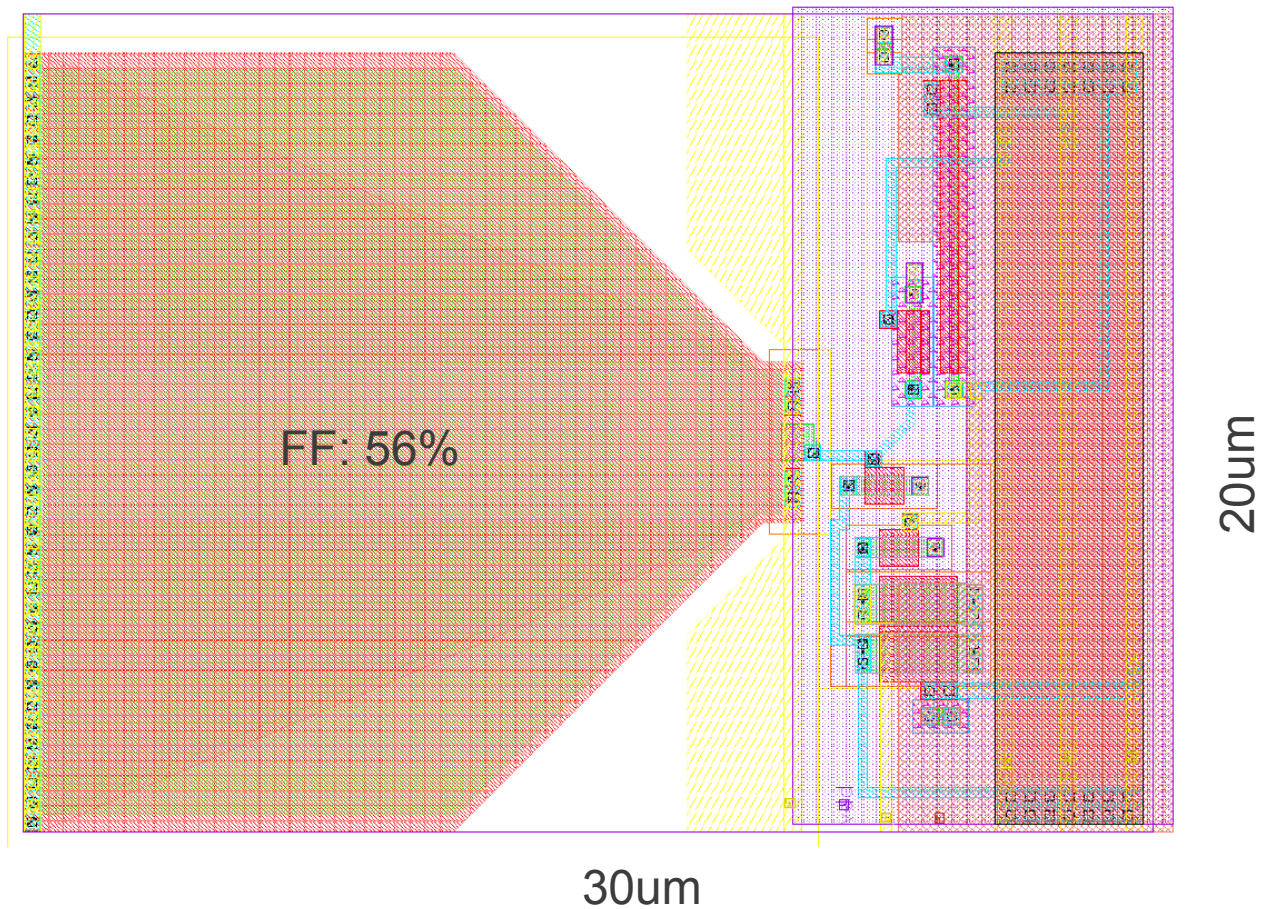

Measurement Results

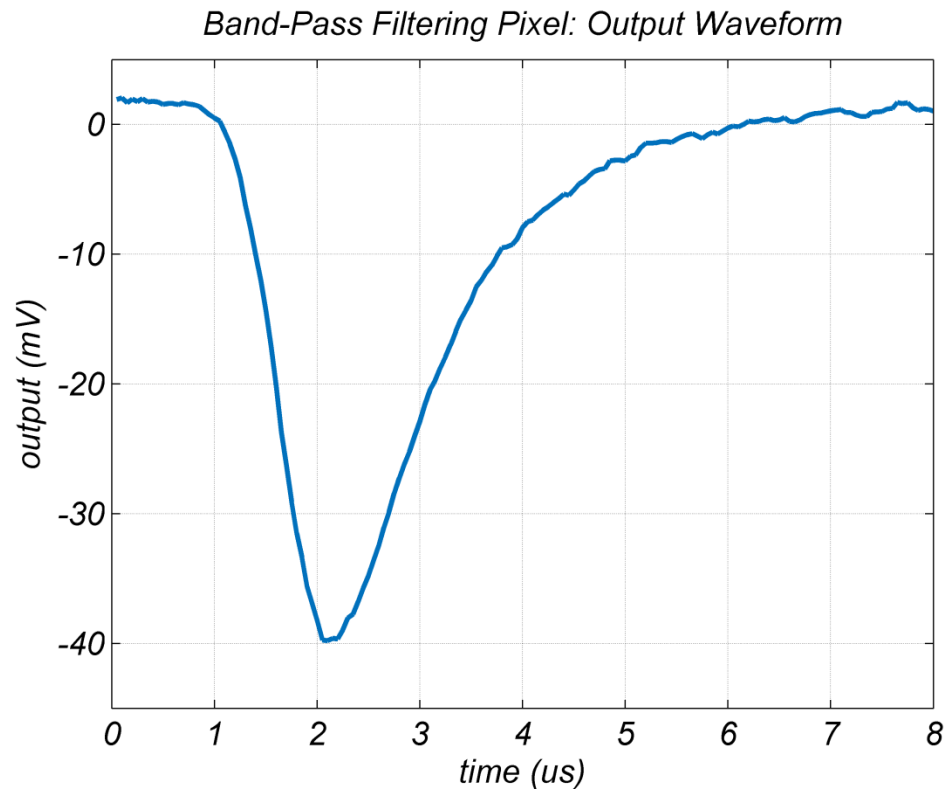

- Pulsed light of visible wavelength
- Pulse width = 1 us
- Repetition rate = 5000 Hz

High-Pass Filter Tuning

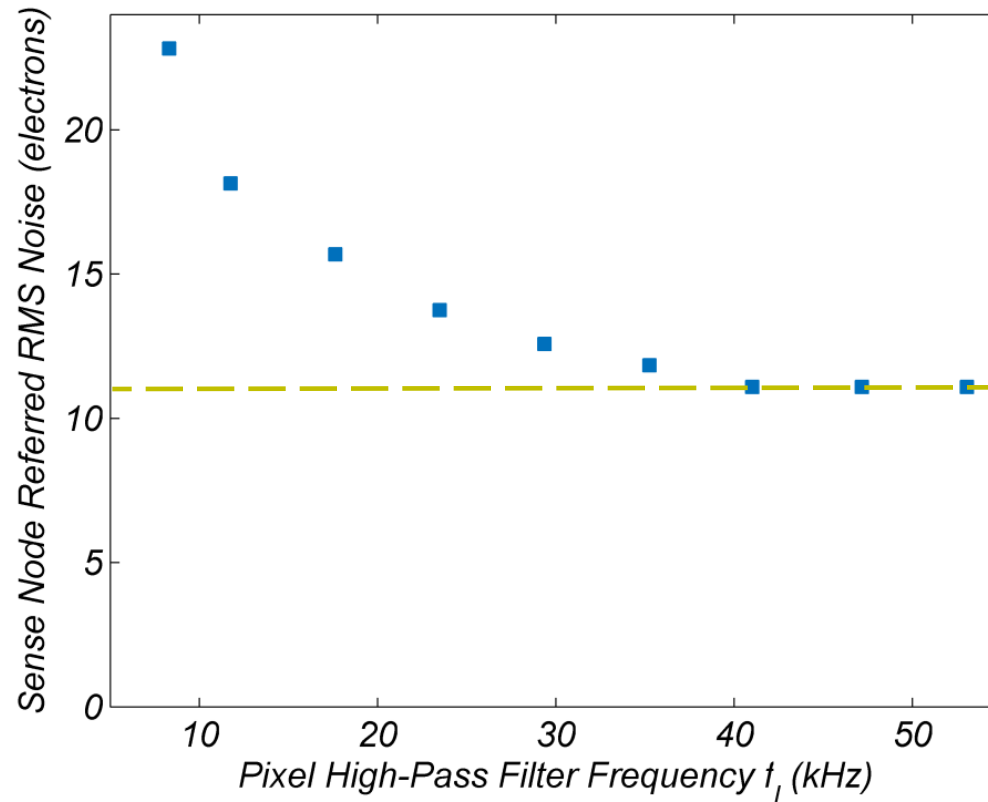

Optimum noise performance: 12 e⁻ ENC

Option: Scintillator based Pulse Detection Pixel

- Structured Scintillator to guide light onto one pixel
- Concept: Filling of trenches in Silicon wafer with scintillator material
- Minimal cross-talk between different pixels
- Low threshold (low noise) pulse detecting pixel required

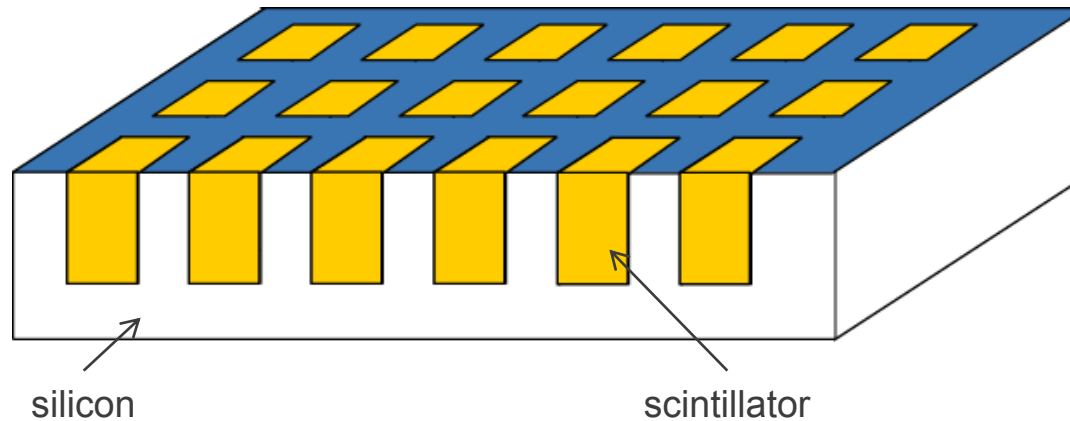

Monolithic Direct X-ray Detectors

- Germanium as detector material

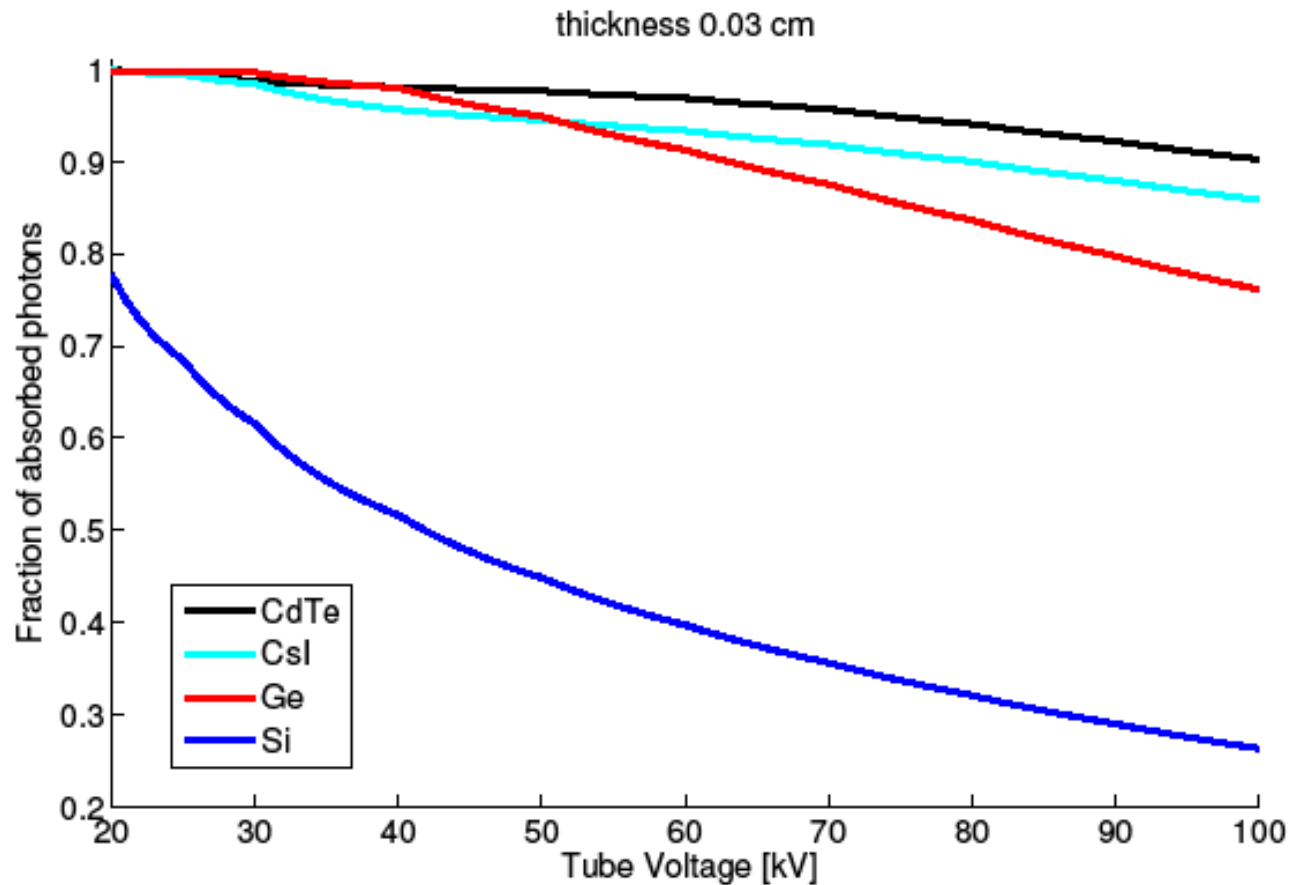

Monolithic Direct X-ray Detectors

- Ge epitaxially grown on backside of CMOS wafer

⇒ Monolithically integrated direct detector

⇒ Challenges:

- Compatible CMOS process ⇒ tungsten metallisation, n-type wafer
- Epitaxial growth of thick hetero-layers ⇒ LEPECVD

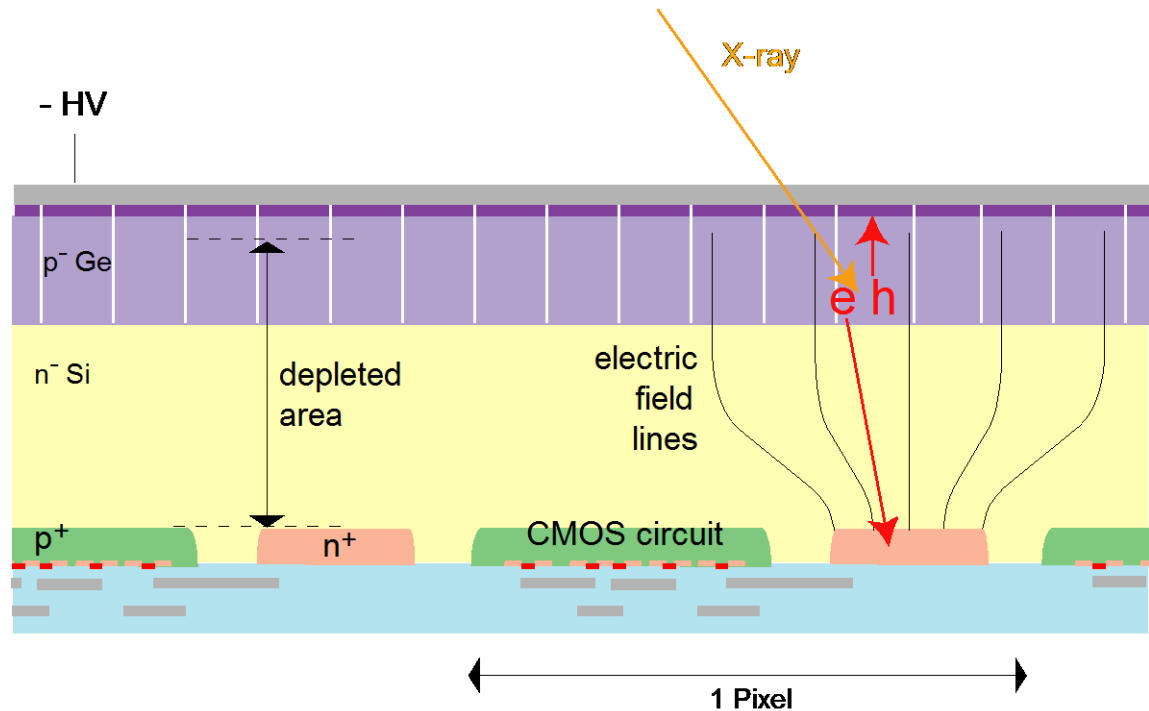

Selective Epitaxy of Thick Ge

con

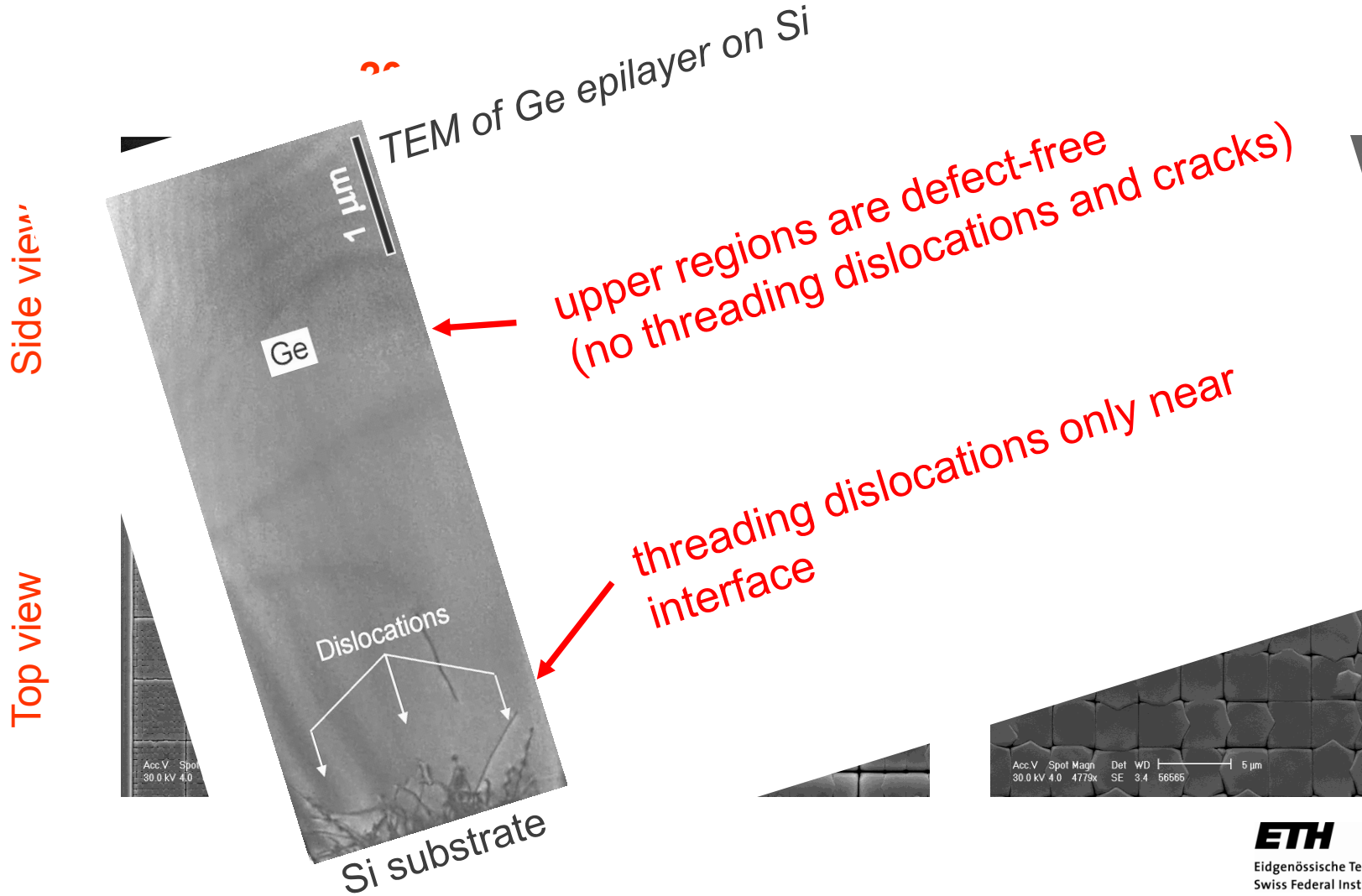

ETH

Eidgenössische Technische Hochschule Zürich
Swiss Federal Institute of Technology Zurich

NIR Ge Sensors

- Monolithic integration of Ge photodetectors on CMOS demonstrated for NIR application
- 64 x 64 pixel NIR image sensor exists

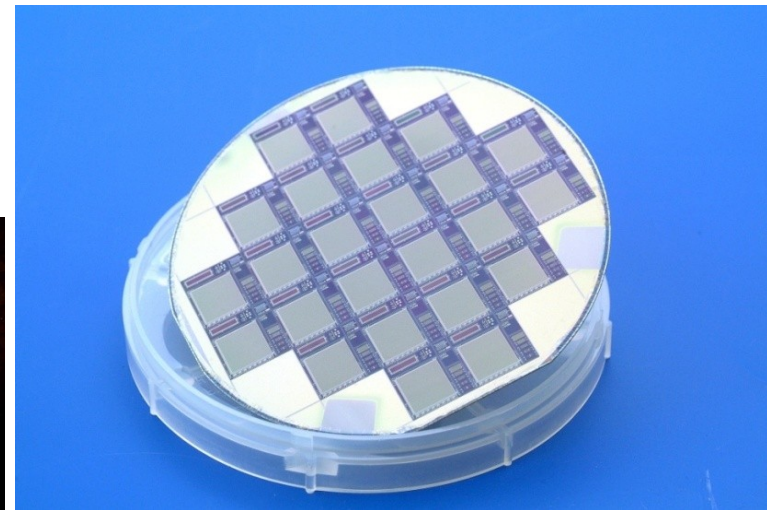
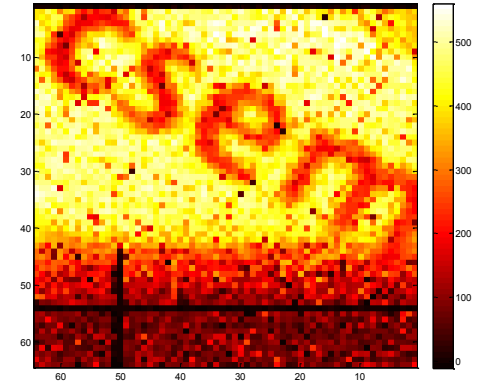
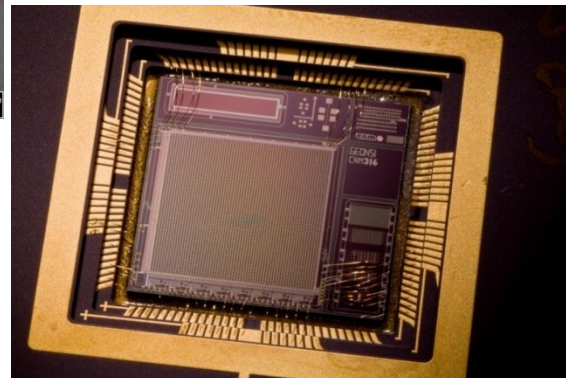
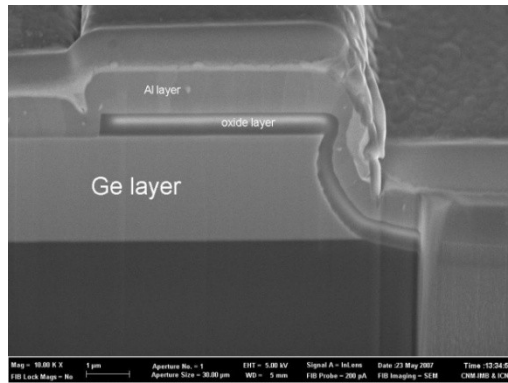

CSEM

... is a research and development company, active in the domains of micro-, nano- and information technology

... is a private company, with mainly industrial, but also public shareholders, not-for-profit

... is under contract by the Swiss Government to perform a special mission in micro- and nanotechnology

... has revenues (2009) of 70 MCHF, today ~ 400 employees, five centers in Switzerland & international activities

Technology transfer

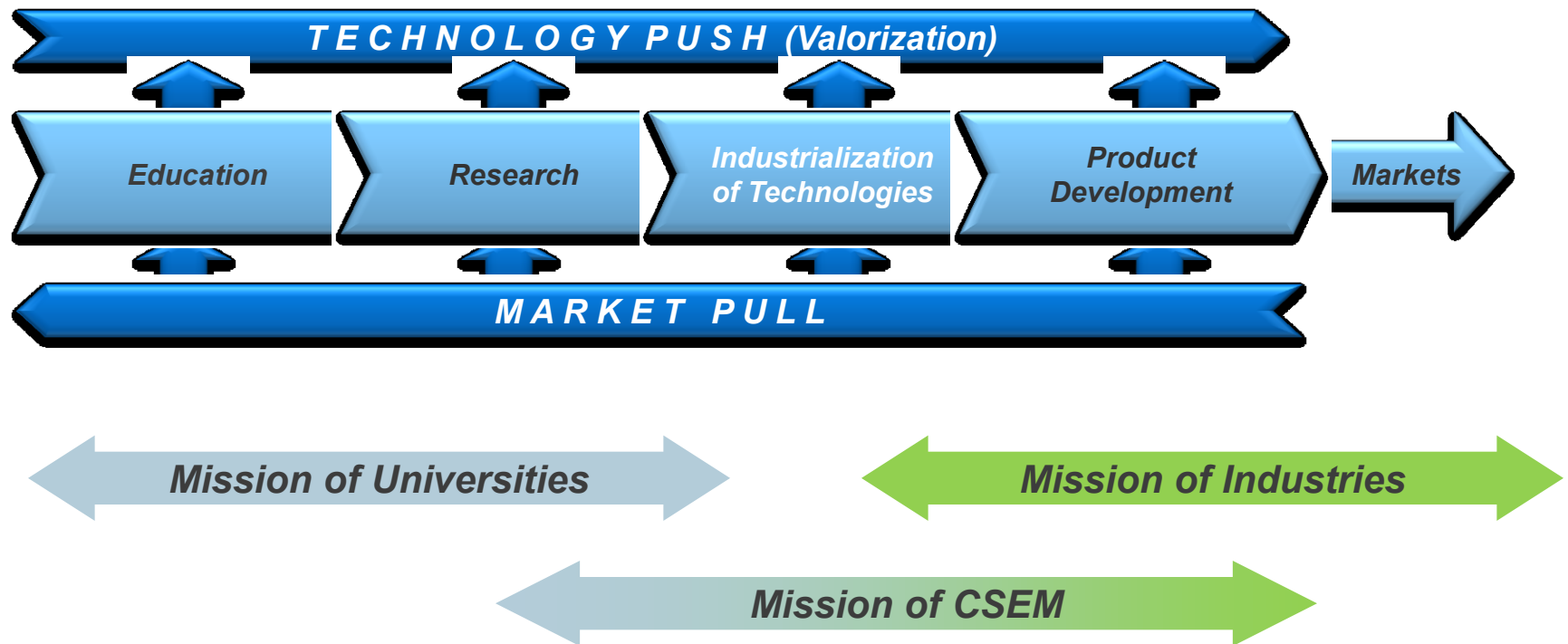

The CSEM Innovation Centers in Switzerland

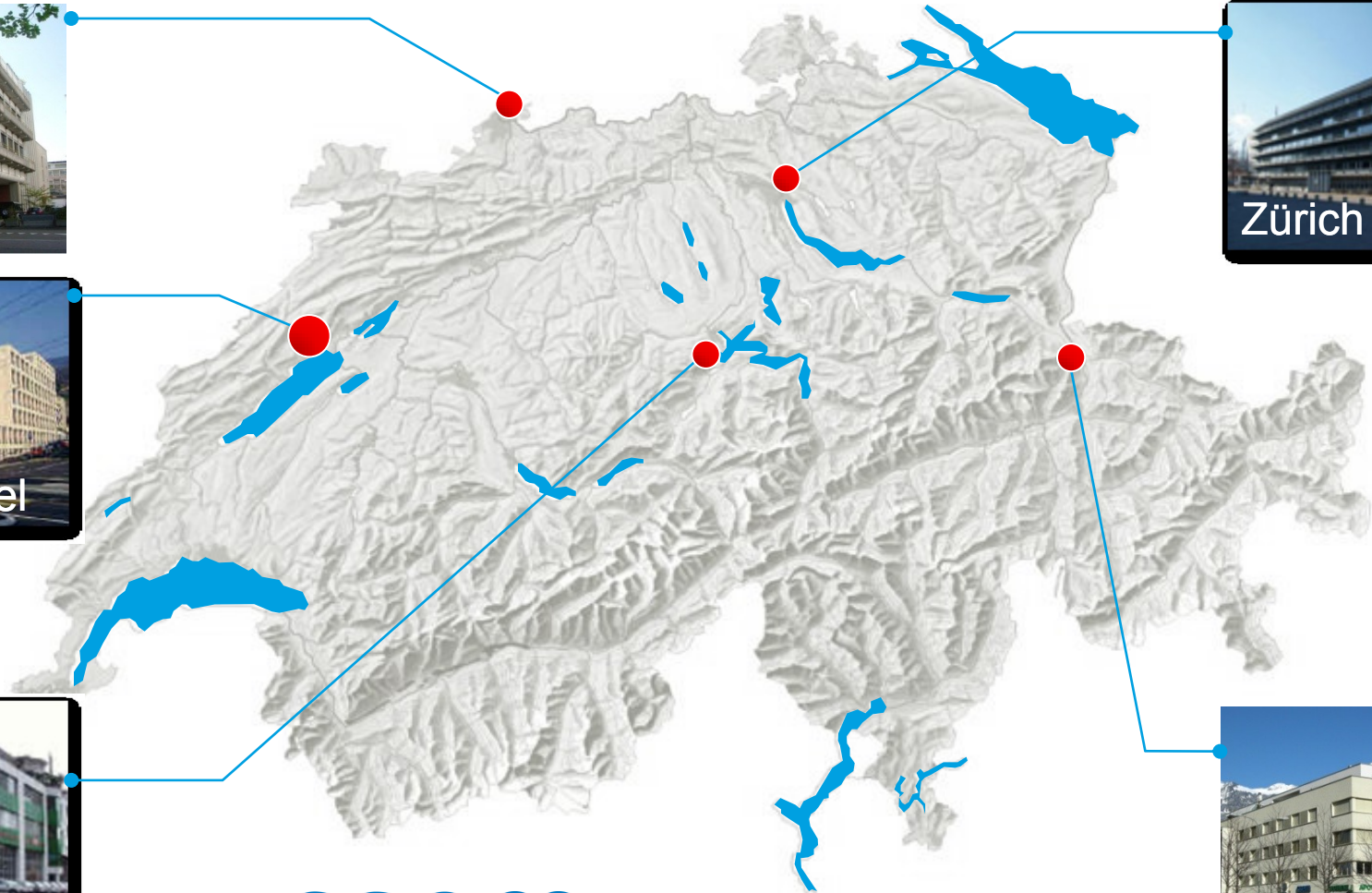
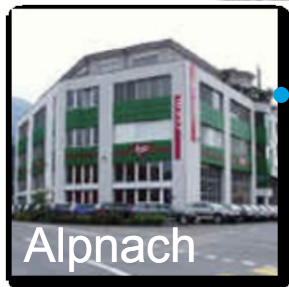

csem

CSEM - Photonics

Technoparkstrasse 1
8005 Zurich
Switzerland

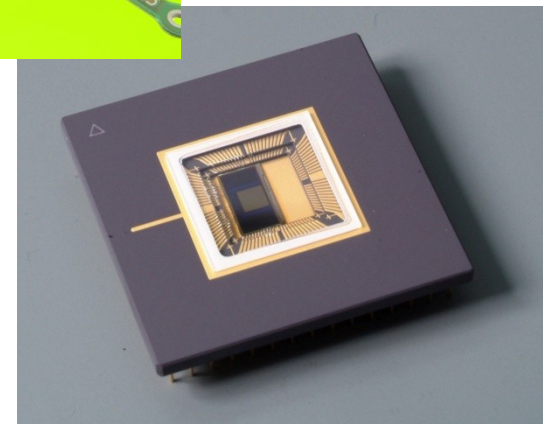
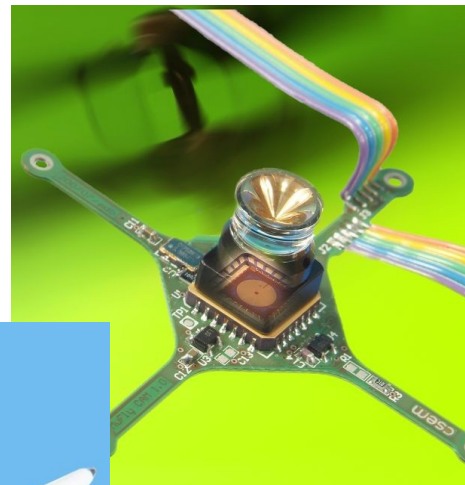
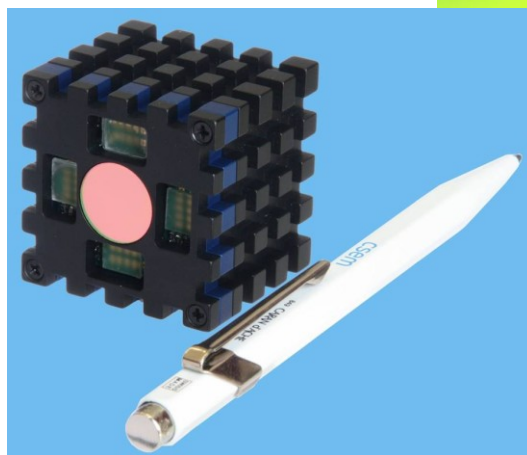

Specialties and Competencies

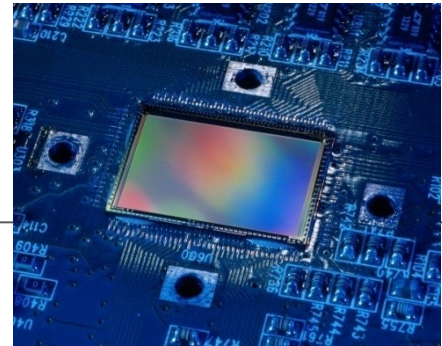

- Optical systems in the VIS and NIR
 - Image sensor desing
 - Optical design
 - Optical and electrical characterisation
- X-ray imaging
 - Phase contrast x-ray
 - X-ray detection
- Image processing software
- Integrated sensor systems

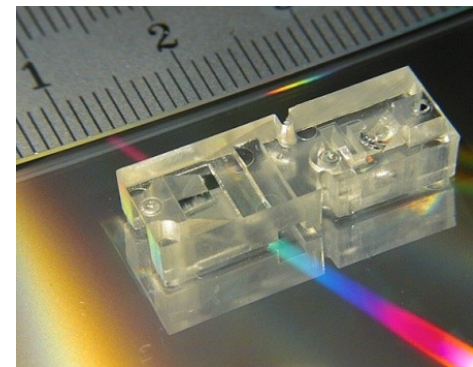
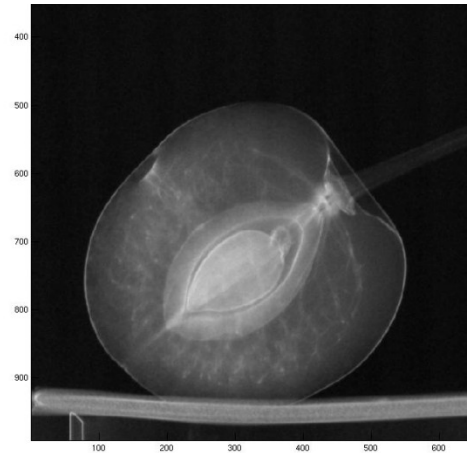

Division Photonics

- 26 employees
- Mainly physicists and electro-engineers
- 2 PhD students
- International projects
- 1'100 m² office, dark room and lab space

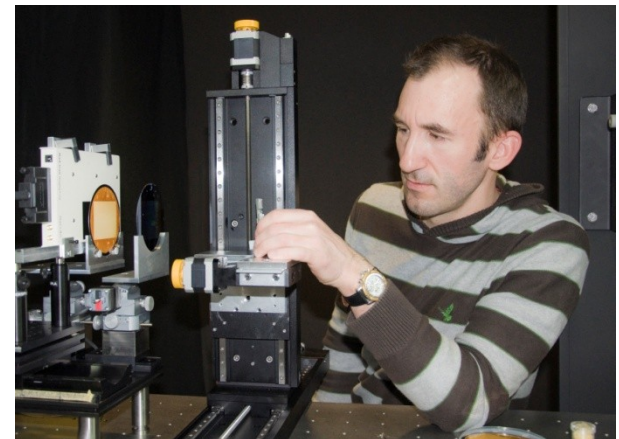
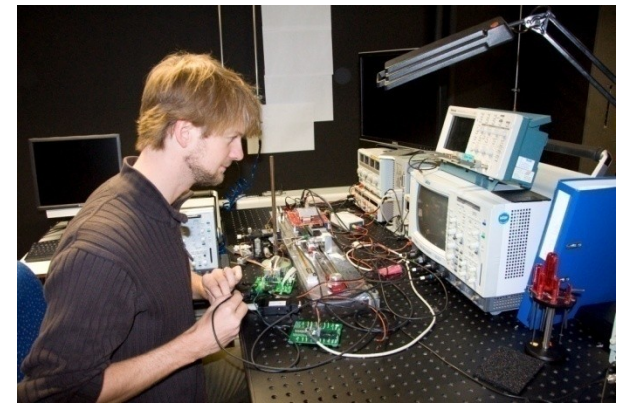

How to Implement Single Photon Detection in Visible Domain ?

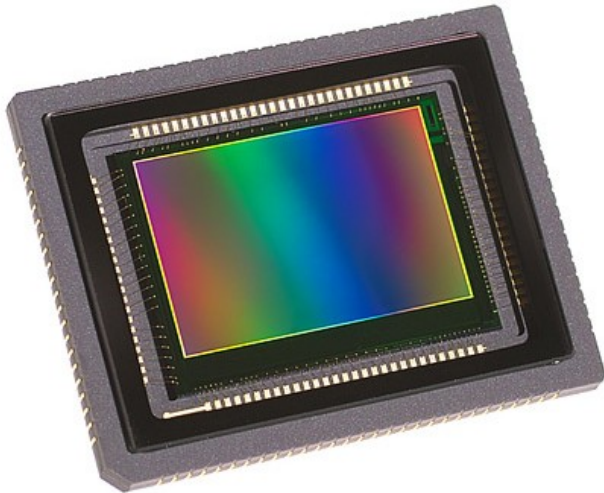

- Extremely low noise levels necessary for photon resolution (< 1 electron ENC)
- Today's image sensors use mostly integrating and not pulse counting circuits (except SiPM / APD arrays)
- Two architectures prevalent today:

Charge Coupled Devices (CCD)

- Charge “buckets” implemented as MOS capacitors
- Charge transport almost noise free
- Noise from
 - Leakage currents (~ 10 e/pixel/s) can be reduced by cooling
 - Read-out (< 10 e/pixel/s) good transistors difficult to implement in CCD process
- CCD market shrinking for cost reasons

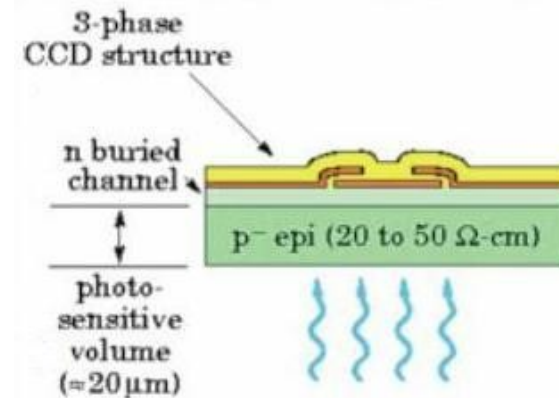
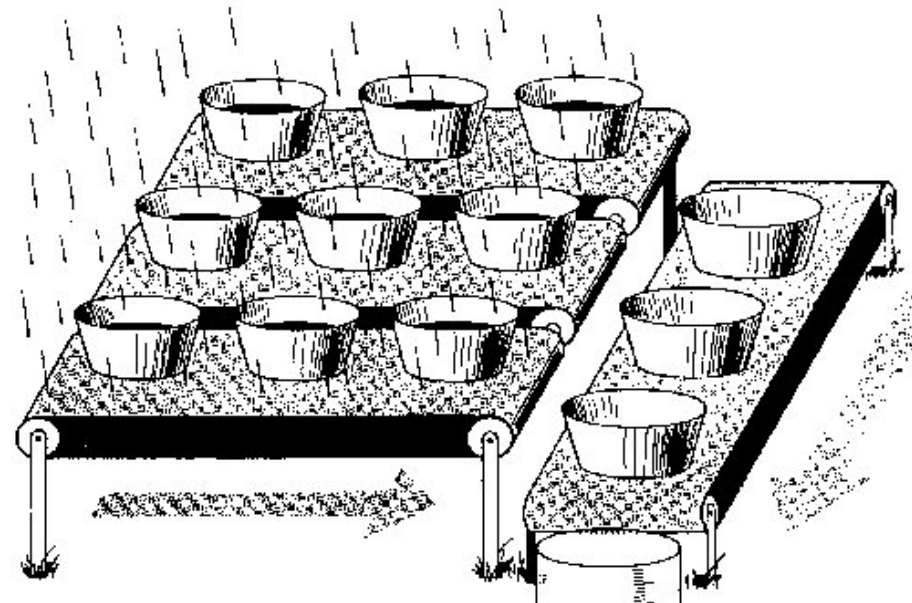

Active Pixel Sensors

- CMOS APS
- CMOS NWEELL as photodiode
- At least 3 transistors
- Global shutter (snapshot) possible with shutter transistor
- Still the usual circuit architecture in image sensors

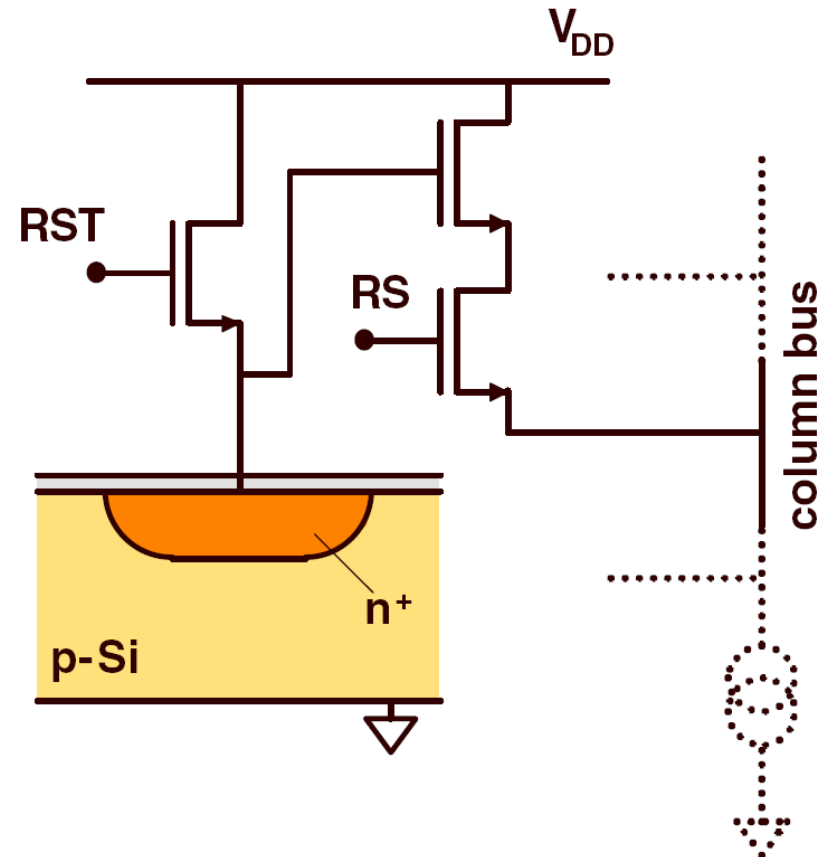

Pinned (Buried) Photodiodes

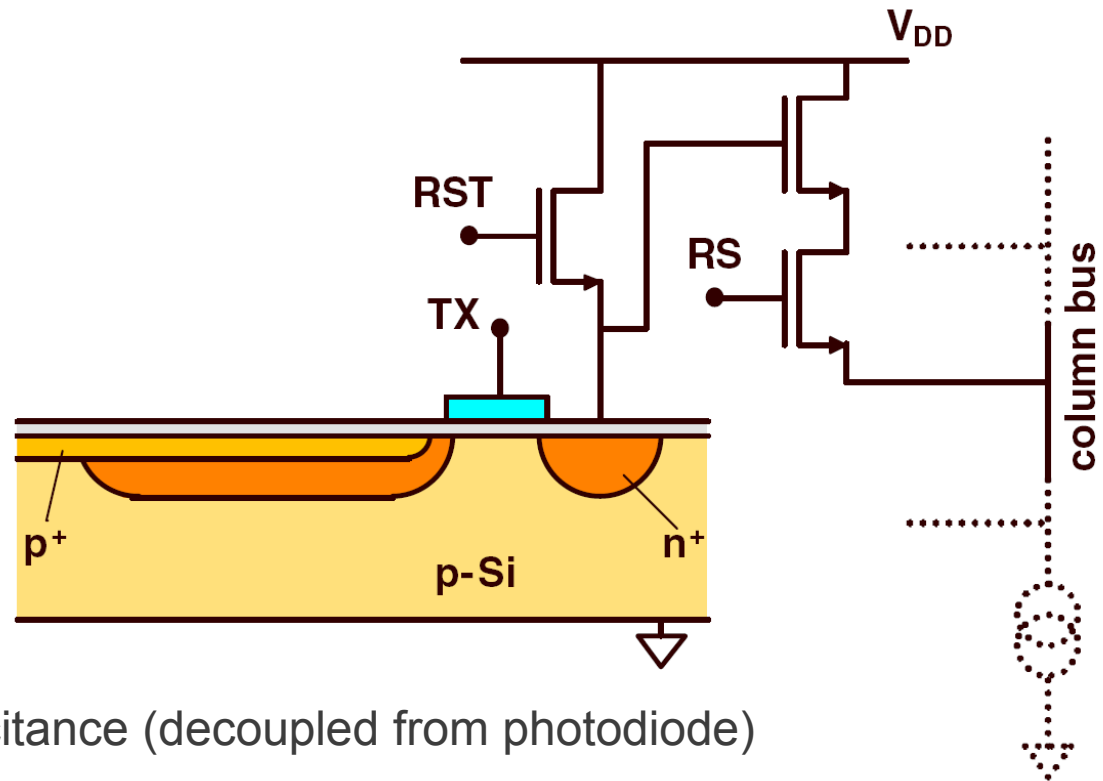

- Low sense node capacitance (decoupled from photodiode)
- Low leakage currents, low trapping probability
- Noise-free transfer of charges from photodiode to sense-nose possible
- Correlated double sampling (CDS) possible

Correlated Double Sampling (CDS)

- Thermal noise in reset transistors causes variations of reset voltage
- KTC noise $q_{ENC,reset} = \sqrt{kTC_{sense}}$
- CDS sequence

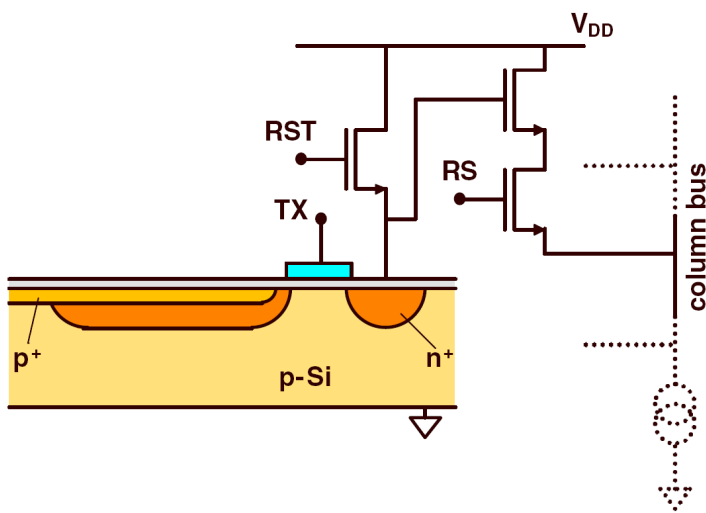

1. Photoelectron integration (PPD)
2. Sense node reset
3. Readout of reset voltage
4. Transfer of photoelectrons
5. Readout of signal voltage

Example: Low-Light and High Dynamic Range (2007)

- 256 x 256 pixels (Testchip)
- 0.18 μm CMOS technology
- Pinned photodiodes
- **Readout noise $< 2 e_{\text{rms}}$ @ room temp.**
- 3-5 photons / pixel
- Dark current of $5\text{pA}/\text{cm}^2$
- Dynamic Range $> 140\text{db}$ using logarithmic compression for high light levels
- One of the most sensitive CMOS sensors at that time (without APD)

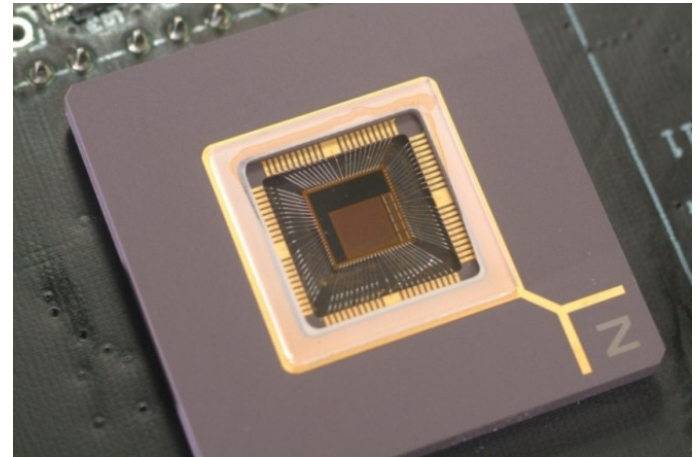

Readout Noise in Integrating CMOS Image Sensors

- Image sensors with pinned photodiodes (PPD) and CDS (Correlated Double Sampling): Readout noise can be dominant sensor noise source
- Readout noise in conventional image sensors:

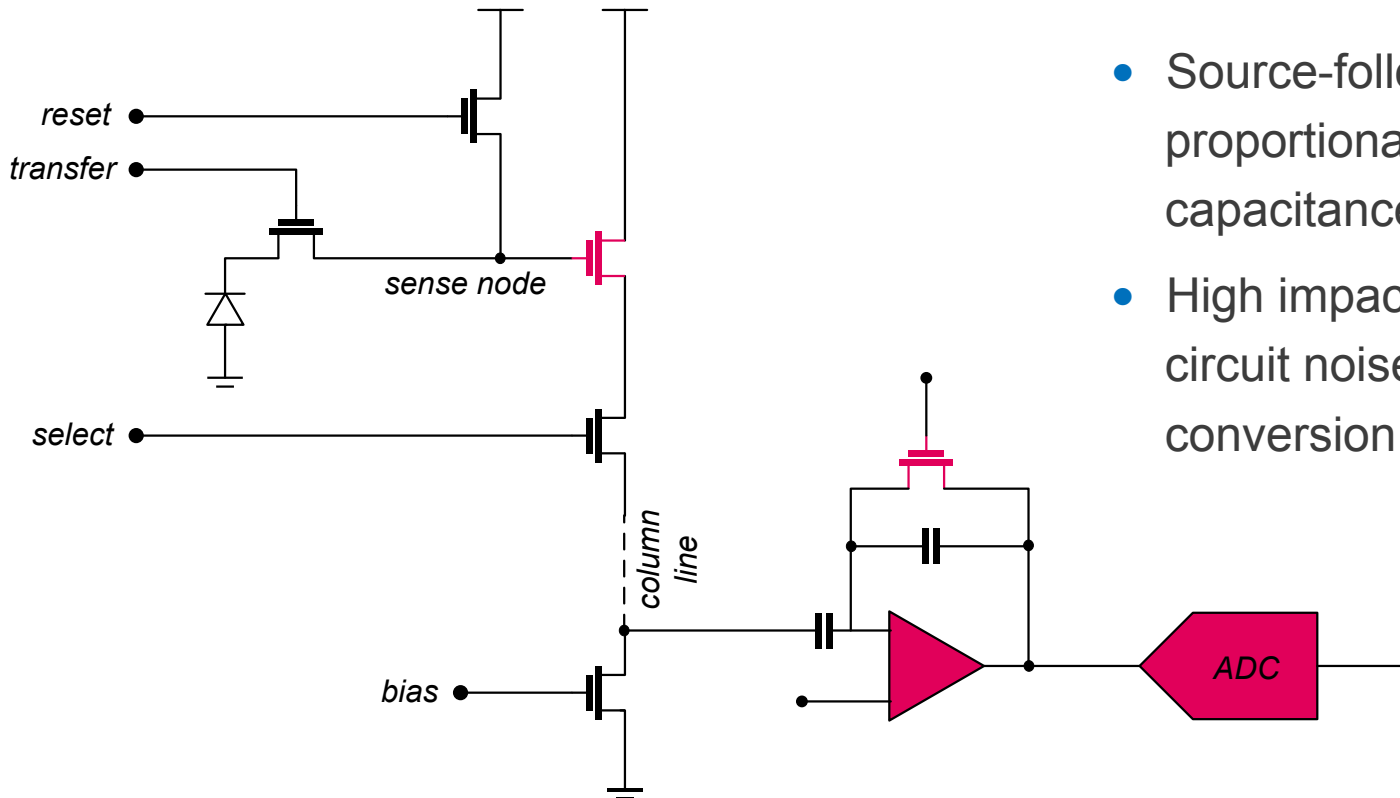

- Source-follower noise: ENC proportional to sense-node capacitance => PPD ideal !
- High impact of downstream circuit noise due to low pixel conversion factor

Amplifying Pixel

Limit bandwidth & reduced impact of downstream circuit noise

Conventional

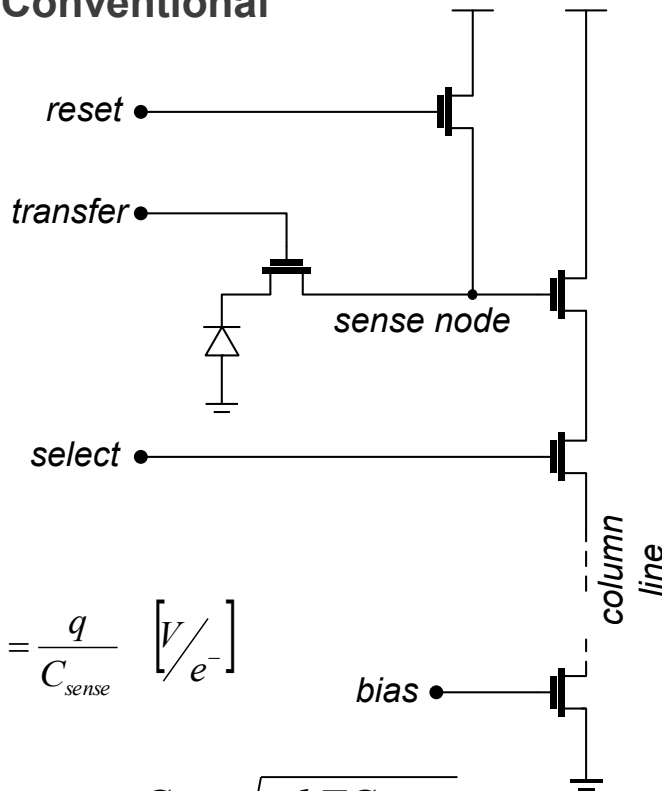

$$CF_{pixel} = \frac{q}{C_{sense}} \left[\frac{V}{e^-} \right]$$

$$q_{ENC,thermal} \cong C_{sense} \sqrt{\gamma kTC_{column}}$$

Amplifying pixel

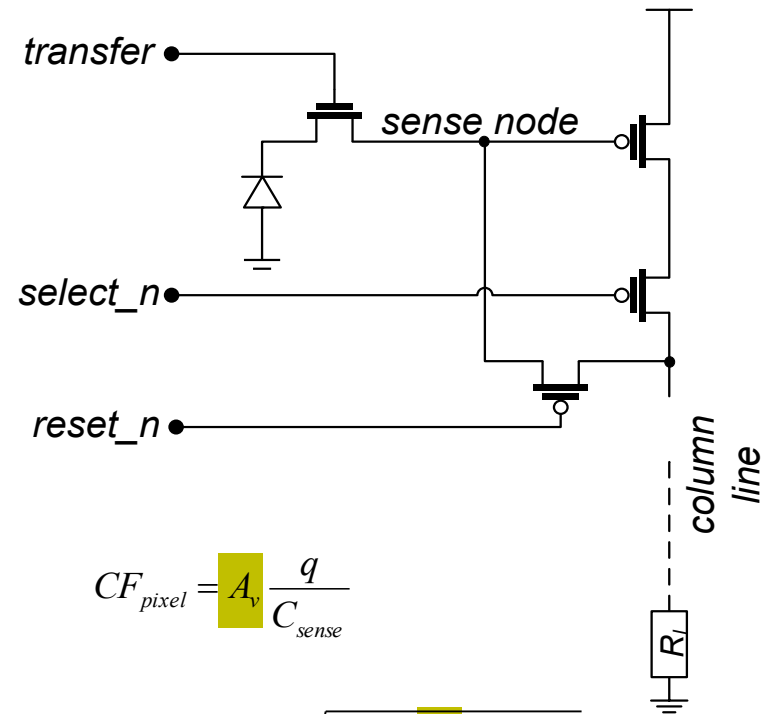

$$CF_{pixel} = A_v \frac{q}{C_{sense}}$$

$$q_{ENC,thermal} \cong C_{sense} \sqrt{\gamma kTA_v C_{column}}$$

Reset Switch

- Reset switch on: reset voltage senses column offset voltage differences
- Guarantees a constant amplifier operating point

Conventional

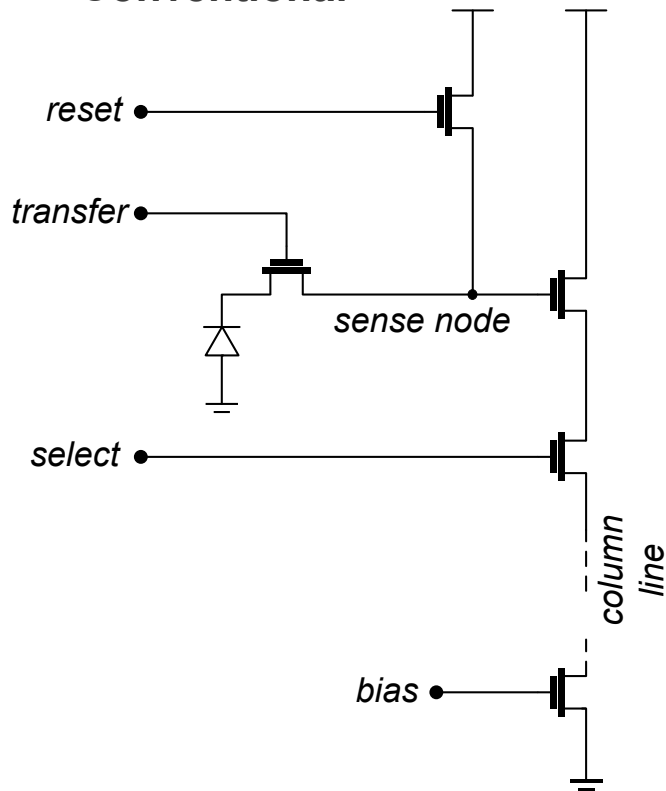

Amplifying pixel

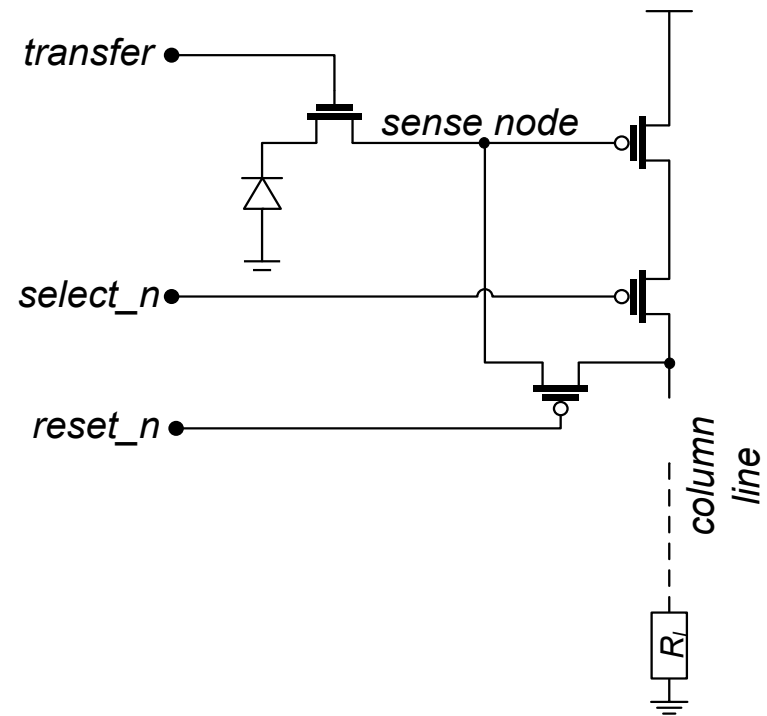

Amplifying Pixel Measurement Results

Parameter	Value
Pixel pitch	11 μ m
Fill factor	40% to 48%
Transistor count	4
Sense node capacitance	5.3 fF
Voltage gain (linear)	9.9
Pixel conversion factor (linear)	300 μ V/e ⁻
Linear range	3 ke ⁻
Full well capacity	34 ke ⁻
Dynamic range ($T_{exp} = 17$ ms)	87.1dB

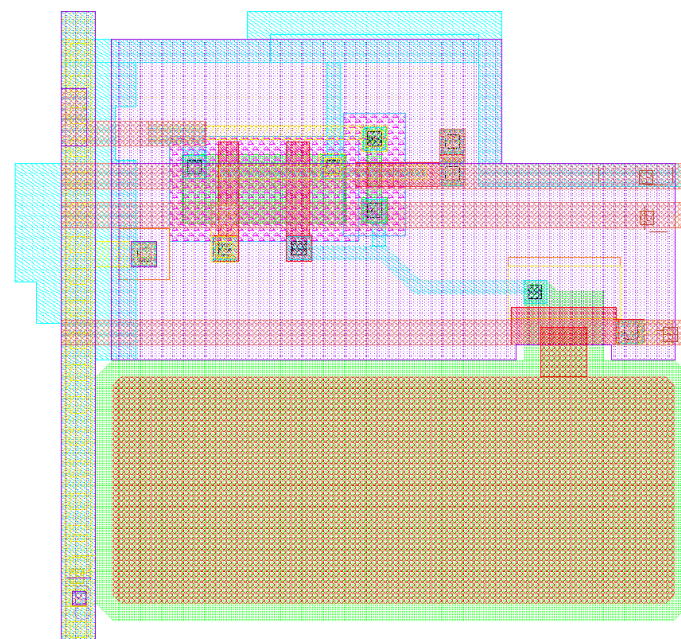

C. Lotto:
Synchronous and asyn-chronous detection of ultra-low light levels using CMOS compatible semi-conductor technologies

PhD Thesis (2010)
University of Neuchâtel

Noise Measurements

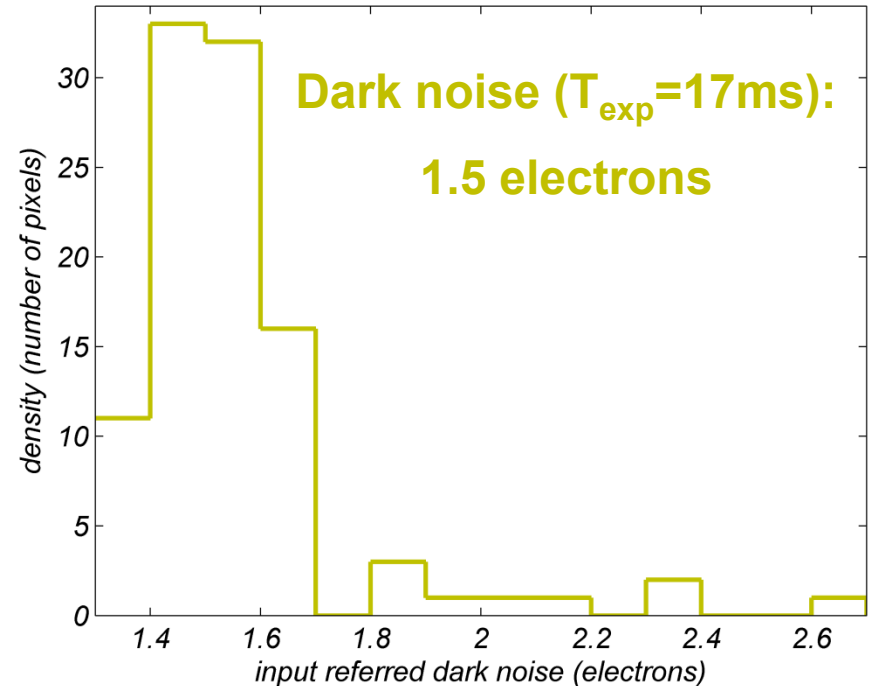
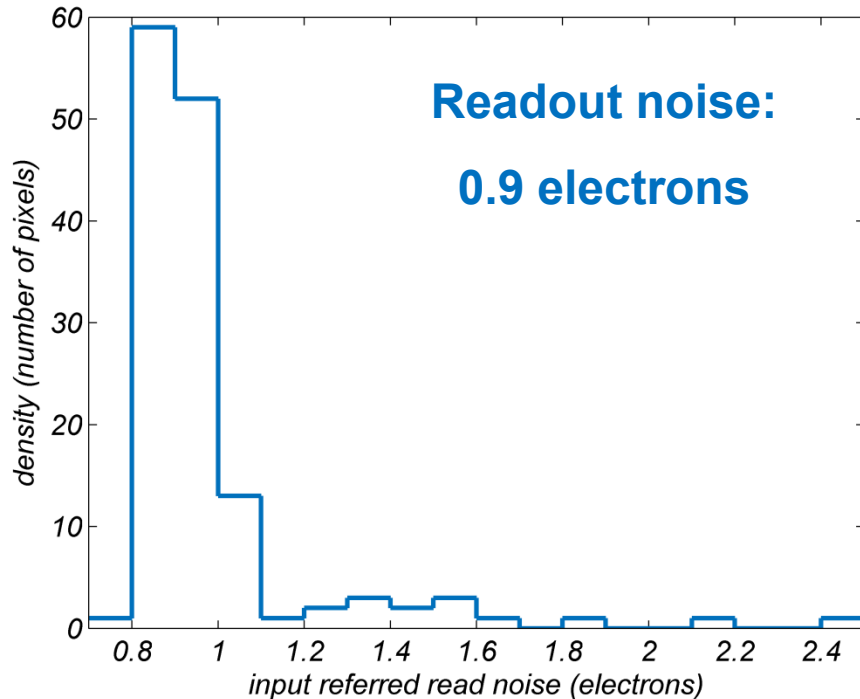

- Readout noise: sequence without activation of TX gate
- Dark noise:
Readout noise + Photodiode dark current shot noise + Transfer noise

Conclusions

- Visible light image sensors are close to single photon detection capability
 - In-pixel amplification including optimized bandwidth engineering
 - Sub-electron readout noise at practical pixel pitch, fill factor, frame rate and dynamic range

- X-ray pulse detection pixels also benefit from low noise circuits
 - In-pixel band-pass filtering
 - Overall noise floor of 12 electrons



Thank you for your attention.