

# Introduction to the MEGII experiment: What? How? Where?

Antoine Venturini  
University of Pisa, INFN



# What is the smallest Branching Ratio in the PDG?



# What is the smallest Branching Ratio in the PDG?

Lepton Family number (*LF*) violating modes [ $\mu$  decay]

$e^- \nu_e \bar{\nu}_\mu$	<i>LF</i>	$[f] < 1.2$	%	90%	53
$e^- \gamma$	<i>LF</i>	$< 4.2$	$\times 10^{-13}$	90%	53
$e^- e^+ e^-$	<i>LF</i>	$< 1.0$	$\times 10^{-12}$	90%	53
$e^- 2\gamma$	<i>LF</i>	$< 7.2$	$\times 10^{-11}$	90%	53



# What is the smallest Branching Ratio in the PDG?

Lepton Family number ( <i>LF</i> ) violating modes [ $\mu$ decay]					
$e^- \nu_e \bar{\nu}_\mu$	<i>LF</i>	$[f] < 1.2$	%	90%	53
$e^- \gamma$	<i>LF</i>	$< 4.2$	$\times 10^{-13}$	90%	53

The **MEGII experiment** will try to push the search for this process to **new limits**. This is a promising way to **hunt for New Physics**



**How:**  
The MEGII  
experiment

superconducting magnet

liquid xenon photon detector

pixelated timing counter

muon stopping target

cylindrical drift chamber

radiative decay counter

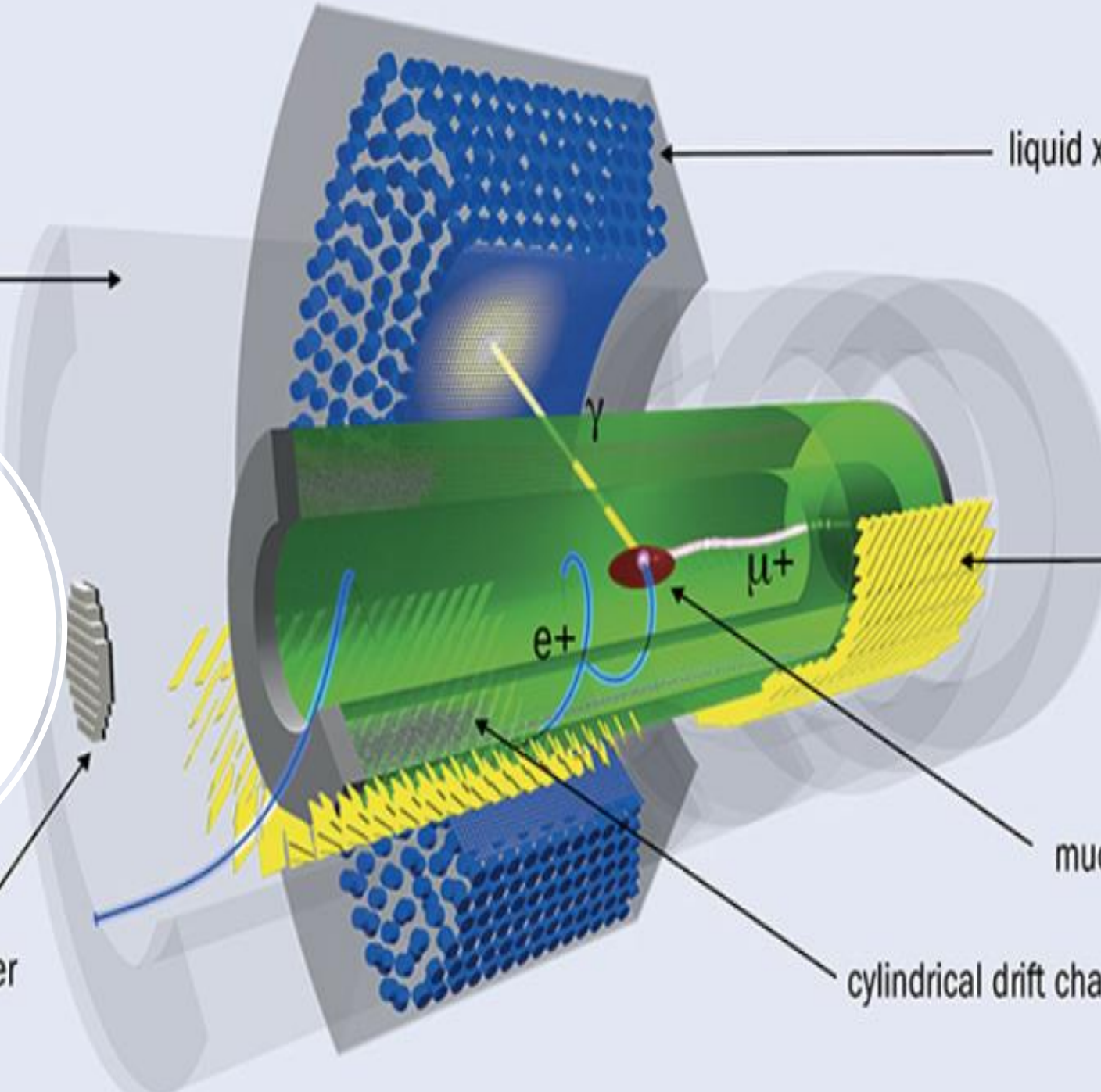

superconducting magnet

liquid xenon photon detector

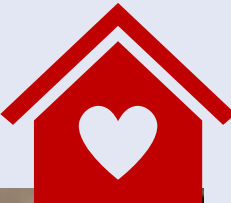

**How:**  
The MEGII  
experiment



The Cylindrical Drift Chamber

radiative decay counter

cylindrical drift chamber

# Where: MEGII Space – Time 4-vector $x^\mu$

$x^i$



# Where: MEGII Space – Time 4-vector $x^\mu$

$x^i$





# Where: MEGII Space – Time 4-vector $x^\mu$

$x^i$

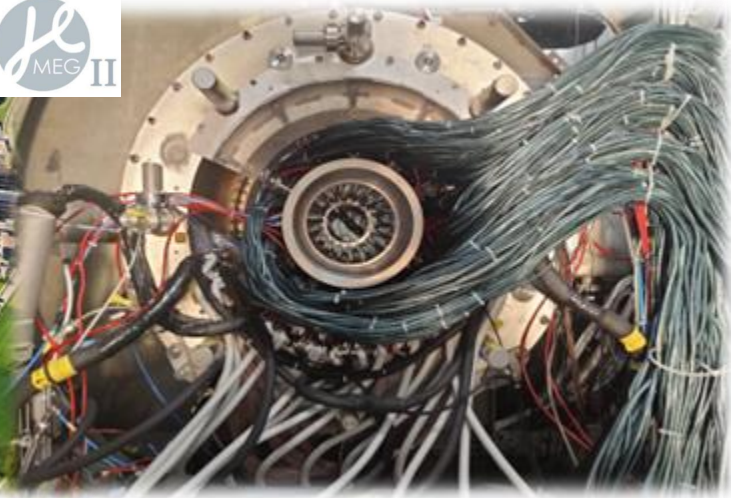

# Where: MEGII Space – Time 4-vector $x^\mu$

$x^i$

$x^0$

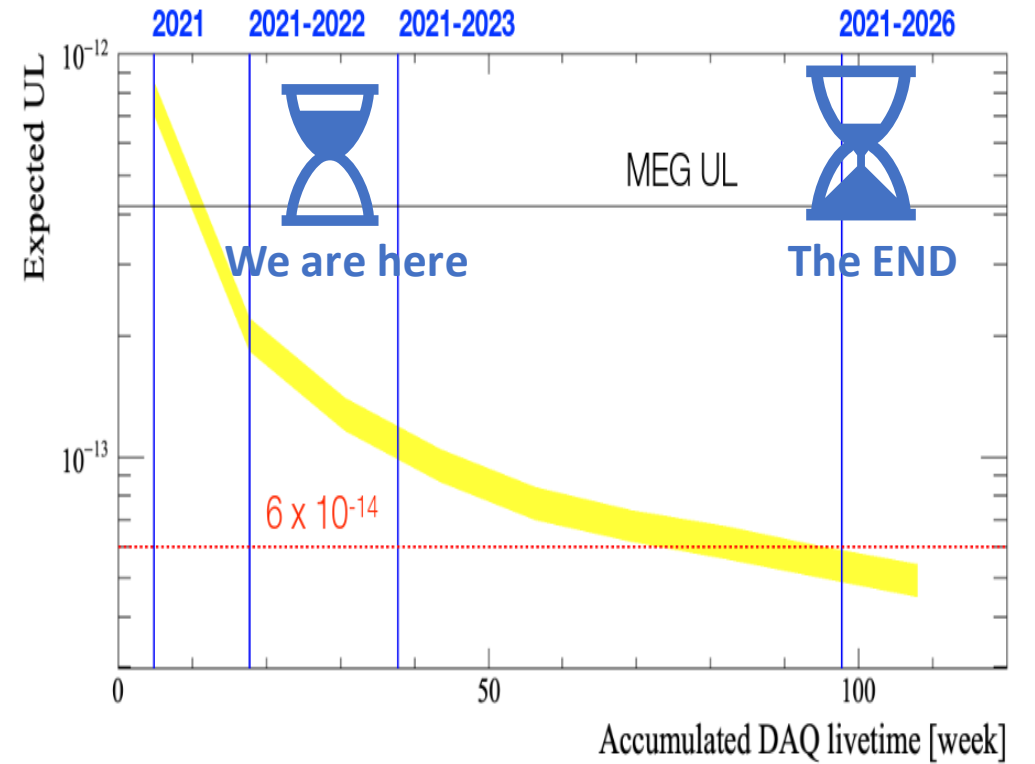
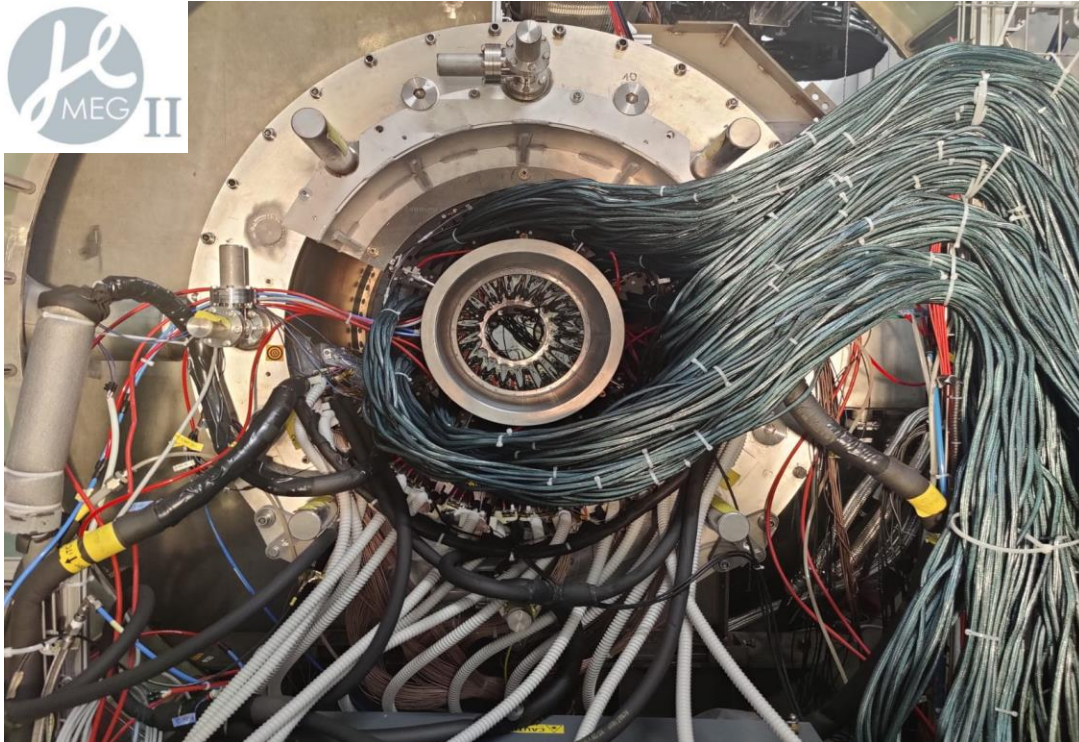

# Where: MEGII Space – Time 4-vector $x^\mu$

$x^i$

$x^0$

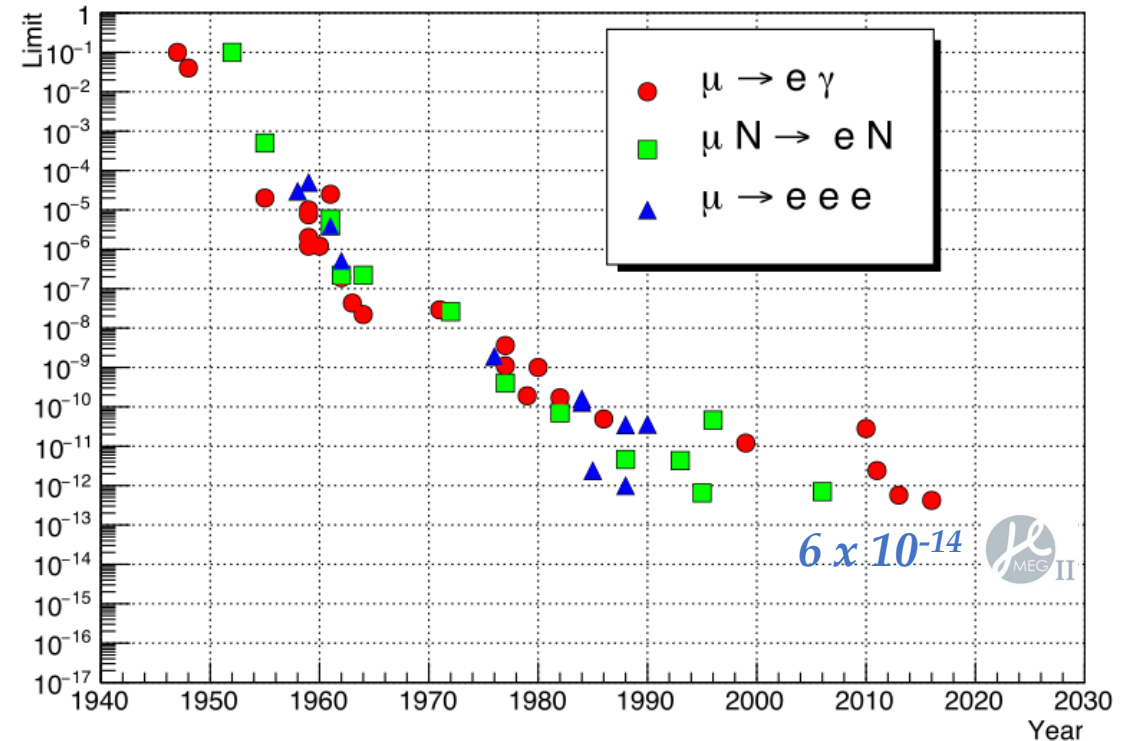
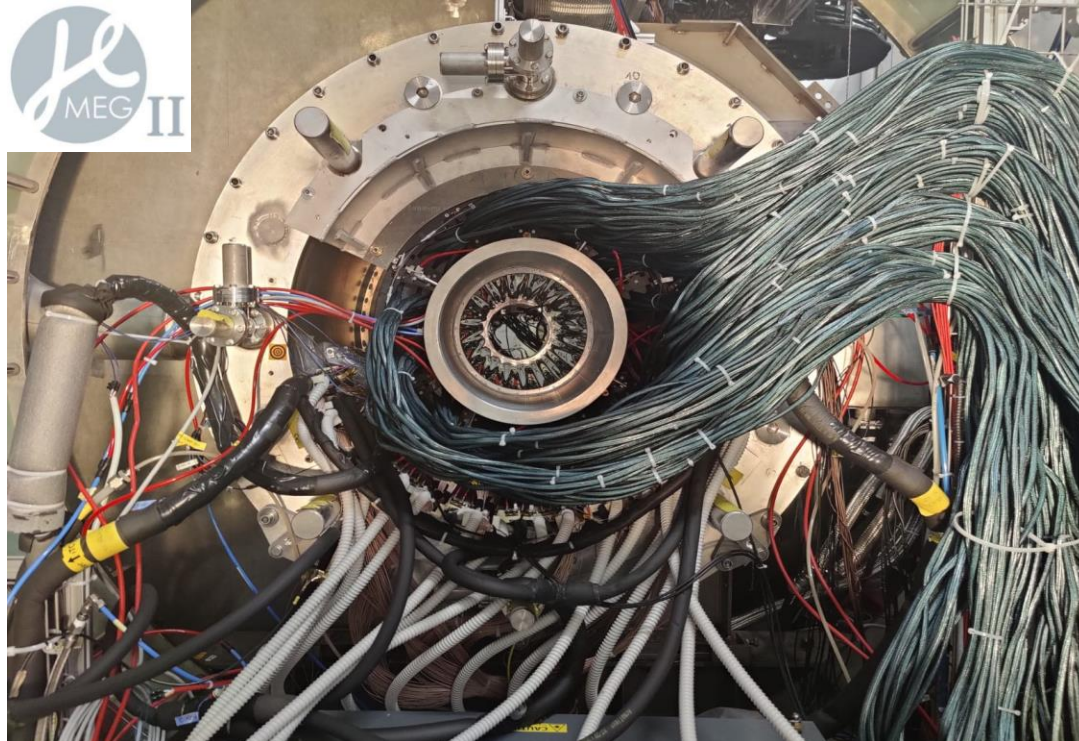

Entering the history of  
charged Lepton Flavor Violation Search

This was just an introduction,  
but MEGII is much more...

