

The ATLAS High-Granularity Timing Detector: test beam campaigns and results

Oleksii Kurdysh on behalf of the ATLAS HGTD group

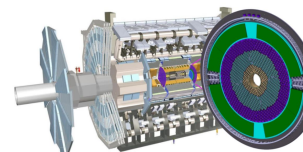

Part 1: Introduction

- For HL-LHC number of simultaneous pp interactions can be up to 200 and separating pile-up from event of interest becomes more challenging

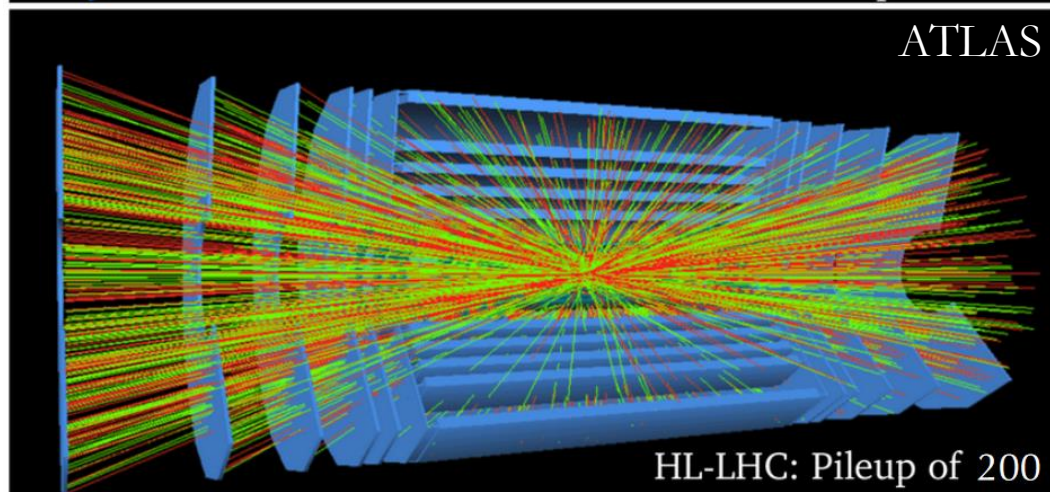
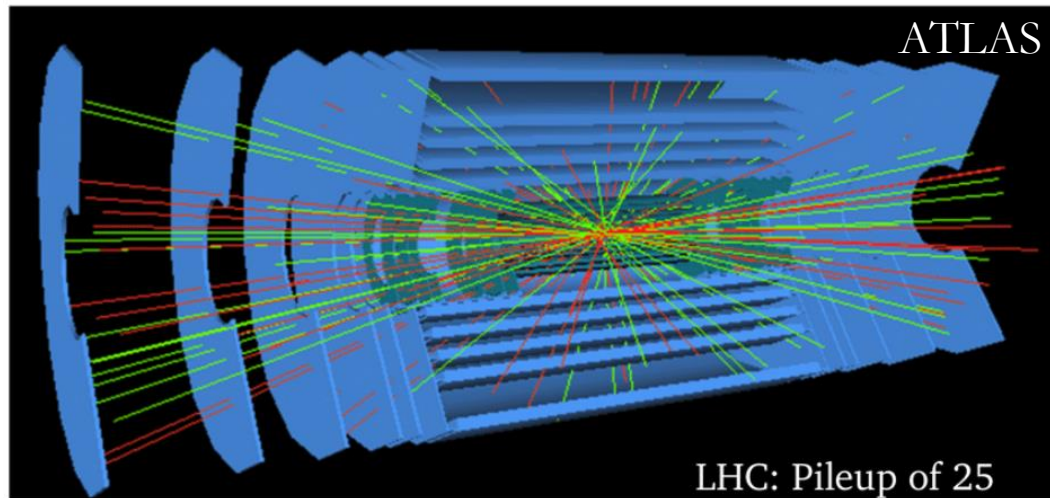

- Timing information can be utilized to reject PU, complementing the position measurement with the new ATLAS Inner tracker (ITk)

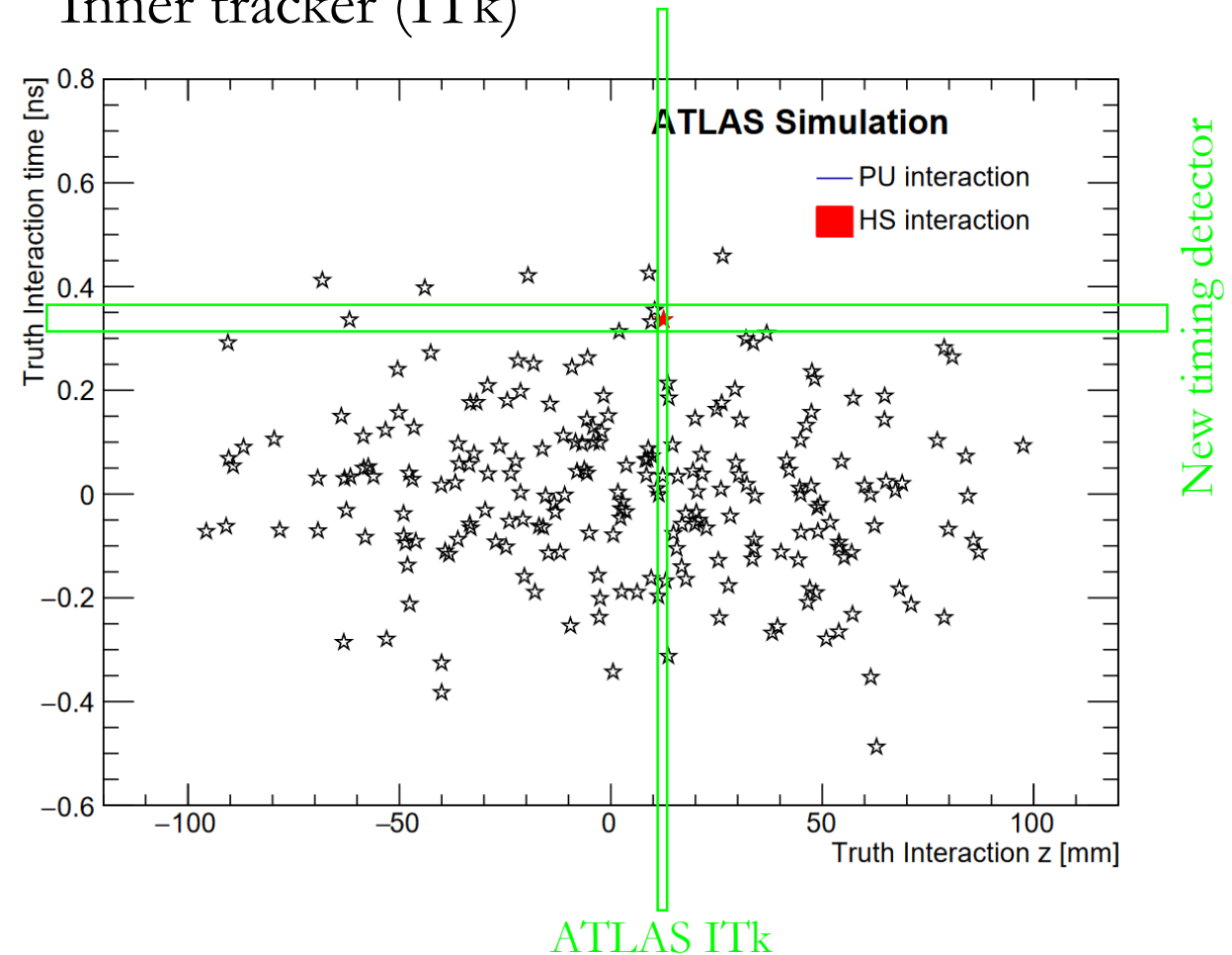

- HGTD will be installed in the forward region of ATLAS to provide precise timing information
- Two instrumented double-sided layers in each endcap

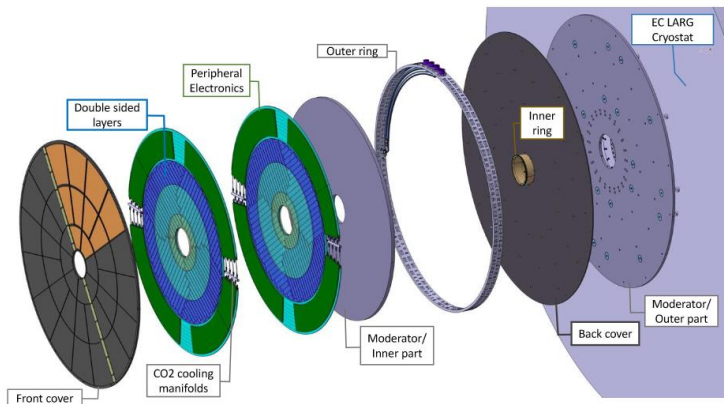
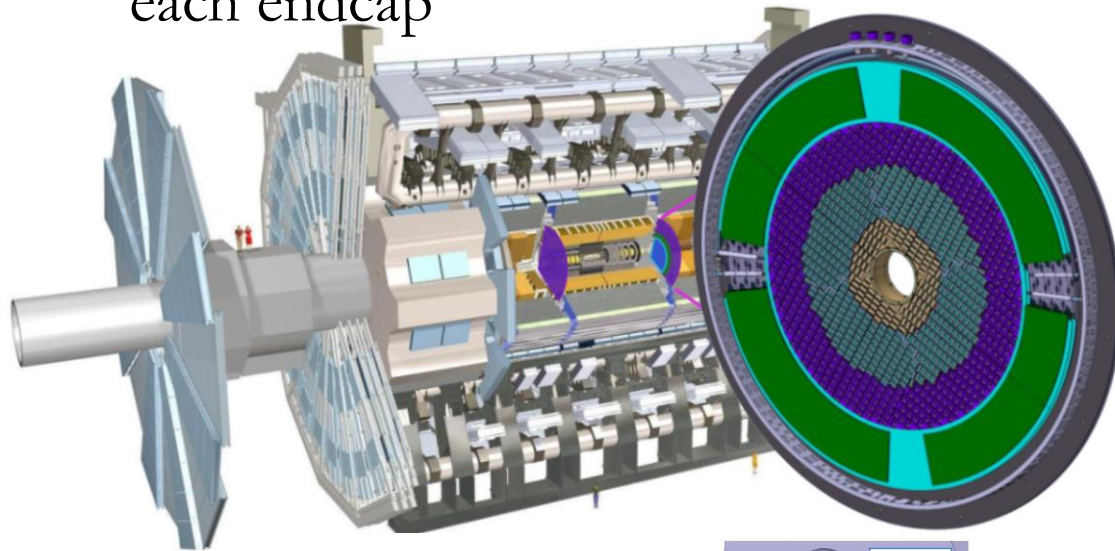

- Example: Using HGTD together with ITk gives improvement in forward pileup jet rejection by up to $\sim 20\%$ (compared to ITk only)

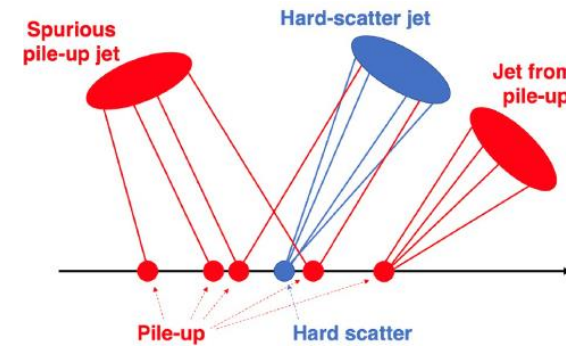
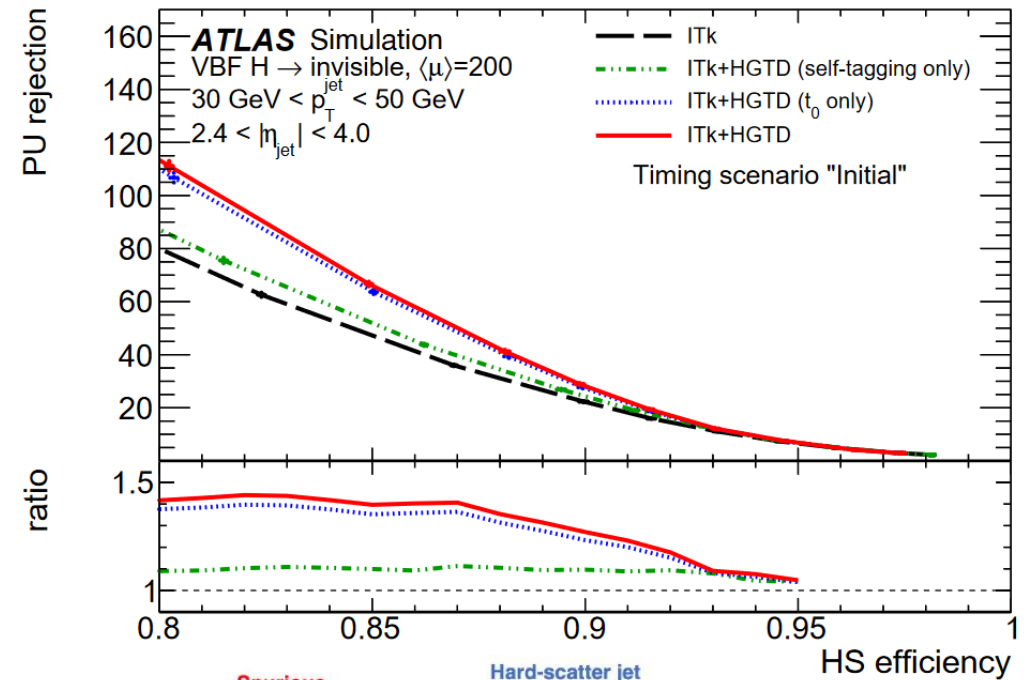

🕒 HGTD must be able to provide time resolution

- 🕒 35 ps/hit (start of operation)
- 🕒 70 ps/hit (end of operation)

🕒 Sensor also must survive the irradiation. Low Gain Avalanche Detector (LGAD) is capable and chosen as sensor

$$\sigma_{\text{module}}^2 = \underbrace{\sigma_{\text{Landau LGAD}}^2}_{\sim 25\text{ps}} + \sigma_{\text{ASIC}}^2$$

$$\sigma_{\text{ASIC}}^2 = \underbrace{\sigma_{\text{TimeWalk}}^2}_{\text{corrected } <10\text{ps}} + \sigma_{\text{Jitter}}^2 + \underbrace{\sigma_{\text{TDC}}^2}_{<10\text{ps}} + \underbrace{\sigma_{\text{LHCclock}}^2}_{<15\text{ps}}$$

🕒 Sensors will be (partially) replaced several times after $2.5 \times 10^{15} \text{ n}_{\text{eq}}/\text{cm}^2$

🕒 Need equally fast read-out electronics: use ALTIROC

🕒 Will have ~ 8000 LGAD+ASIC modules in HGTD

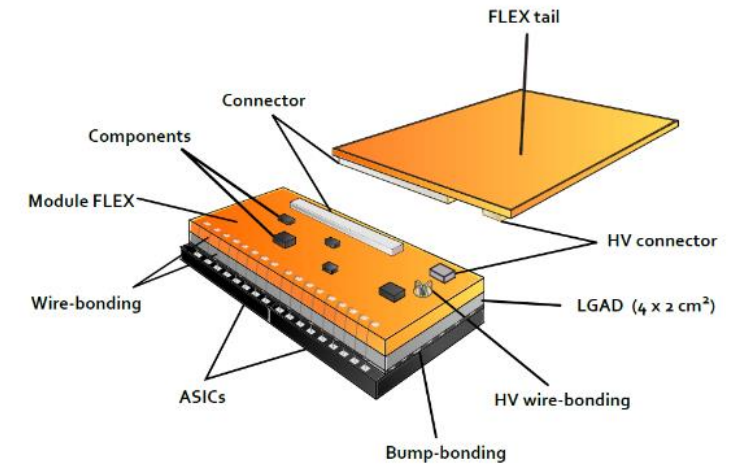
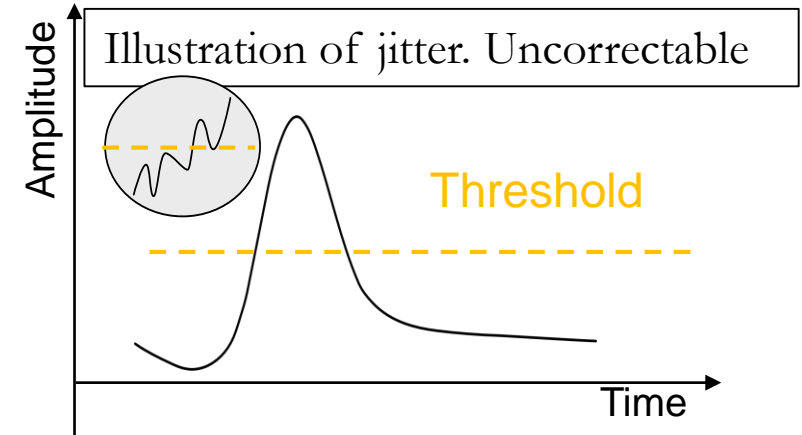

- ALTIROC1 is small-scale 25 (5x5) channel prototype with all analog functionality
- ALTIROC2 is a full-scale prototype with 225 (15x15) channels
 - Should be close to final version

Each ALTIROC channel will provide a TOA and TOT measurements of the LGAD signal for a given threshold.

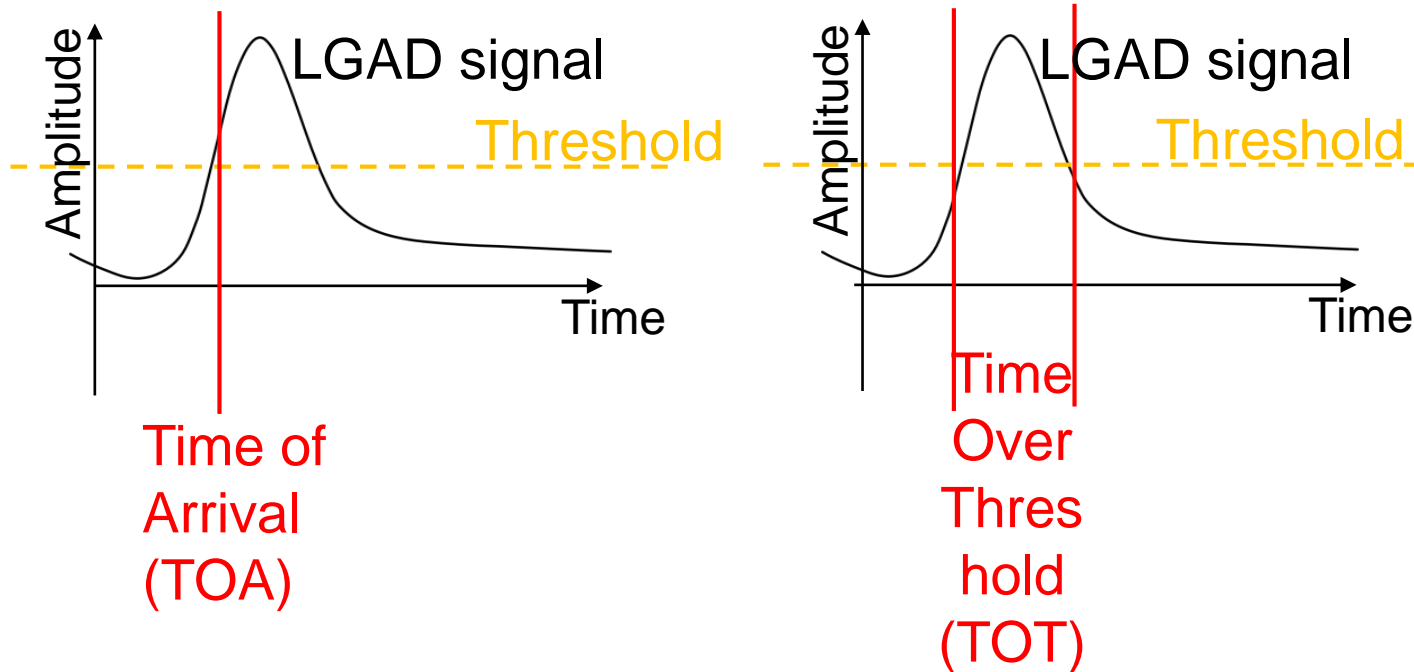

Structure repeated each ASIC channel

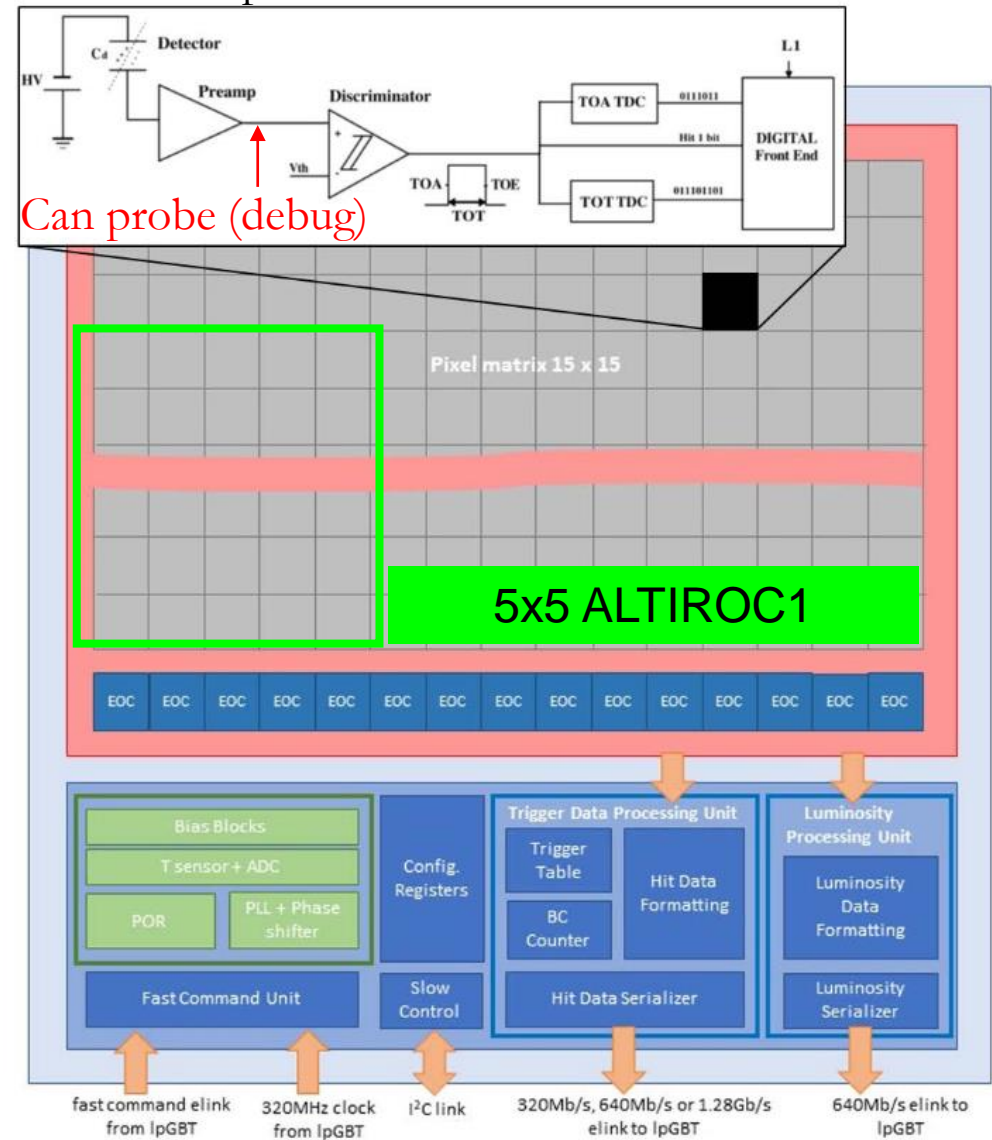

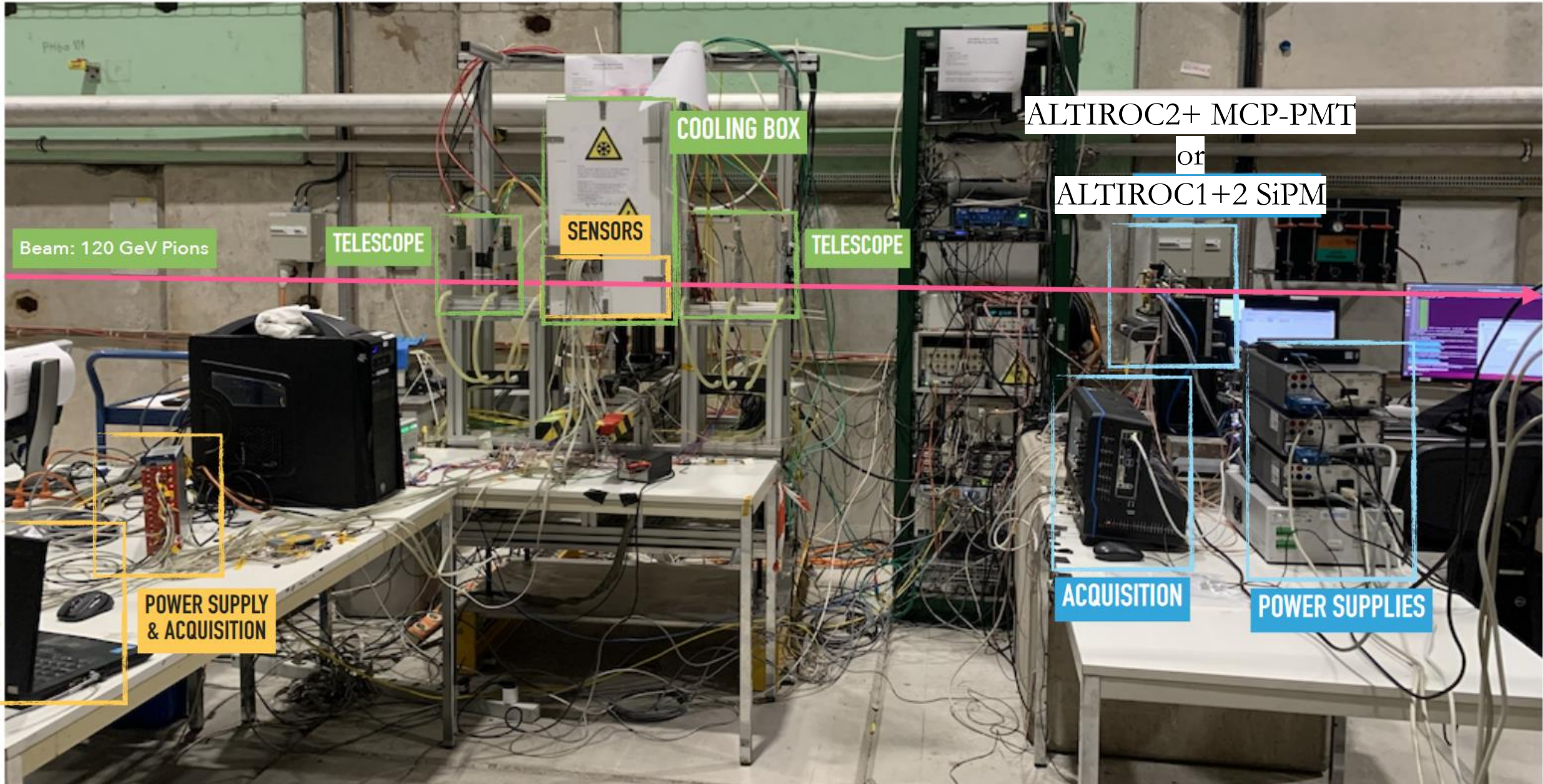

Part 2: GAD performance tests

- LGAD R&D is approaching the final design that should be radiation tolerant and meet the performance requirement after irradiation: $Q > 4$ fC, $\sigma_t < 70$ ps, $\epsilon > 95$ %
- Before unirradiated sensors tested, now radiation tolerance is added by using carbon-enriched LGAD samples. Three vendors considered: FBK, IHEP-IME, USTC-IME
- Sensors were irradiated to 2.5×10^{15} n_{eq}/cm² and then put into DESY (electron), SPS (pion) testbeams. Carbon-enriched LGADs from three vendors meet the HGTD requirements
- Tests are done with custom read-out, not the actual HGTD electronics

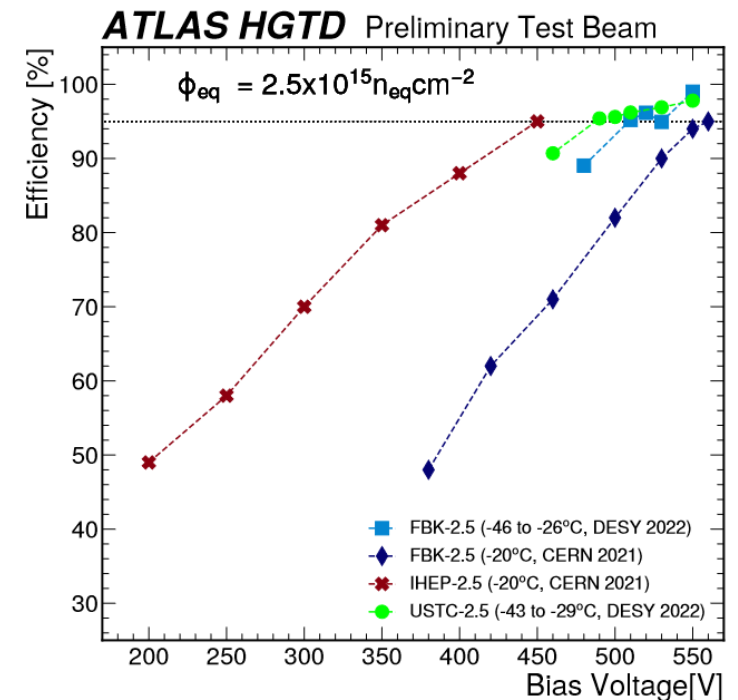
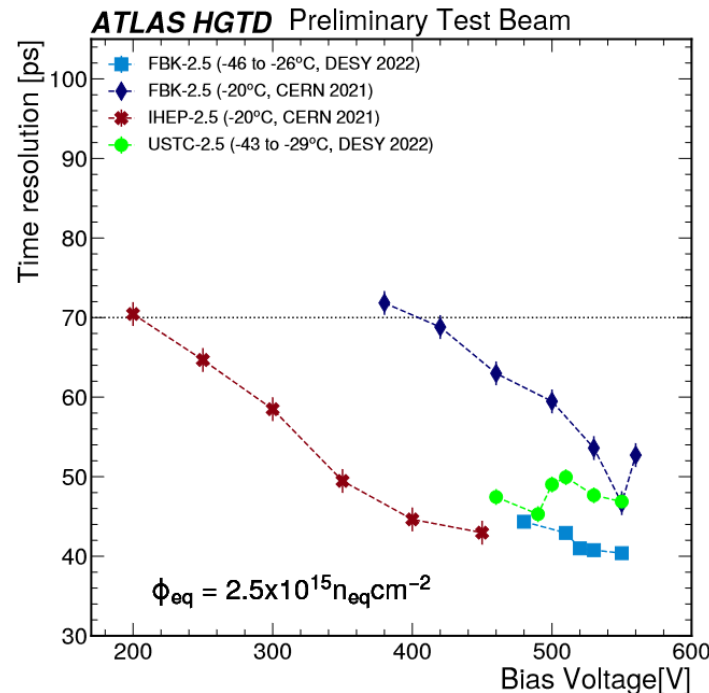
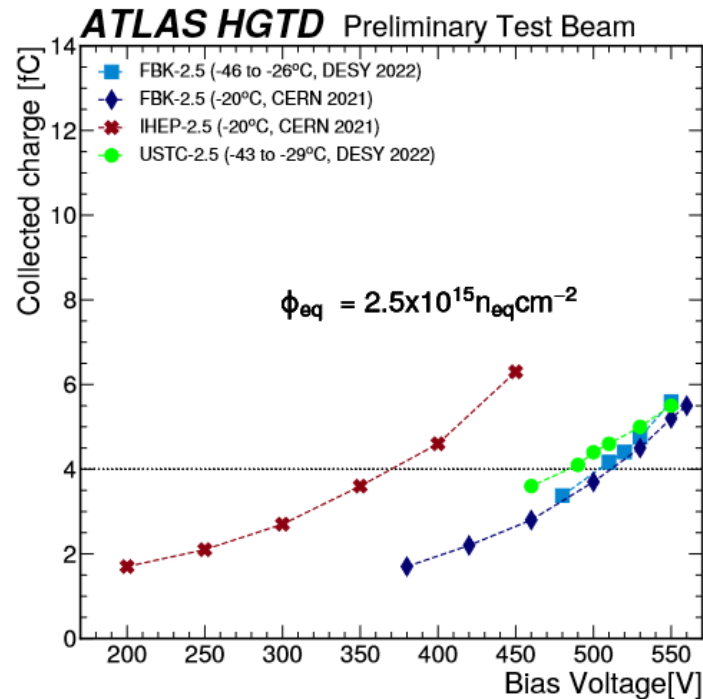

Part 3: ALTIROC1+sensor module tests

ALTIROC1 testbeam setup

ALTIROC1+LGAD tested at room temperature. Two SiPMs are needed in order to solve for module time resolution (LGADs mounted on custom readout boards were tested in parallel)

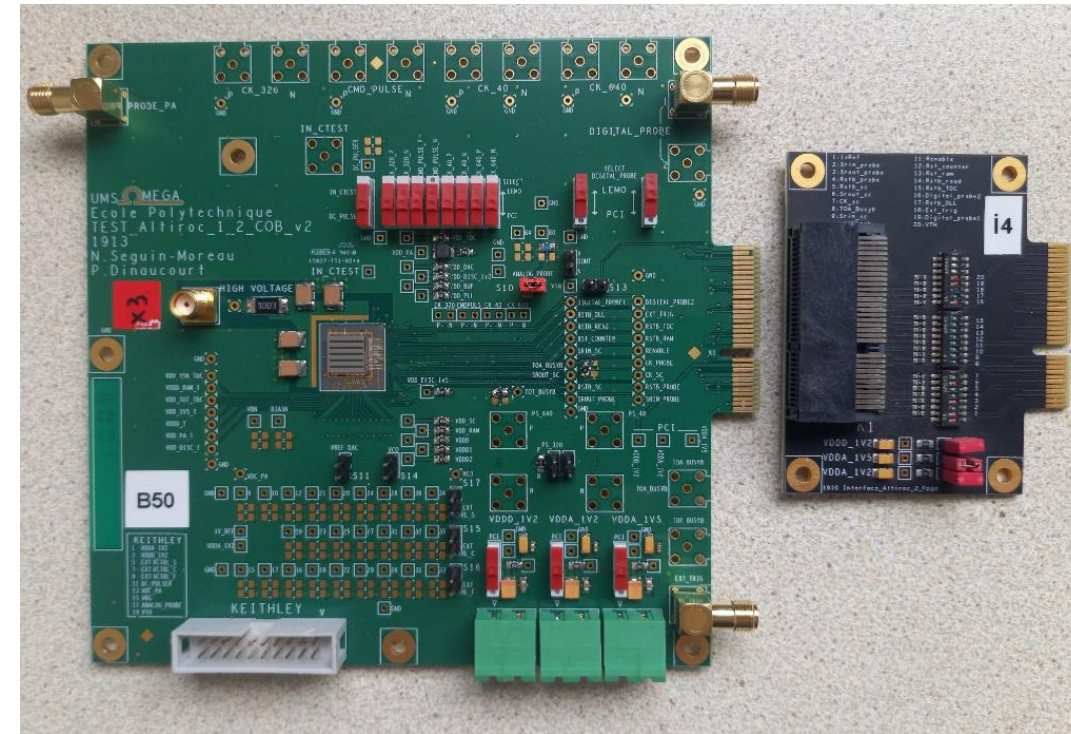
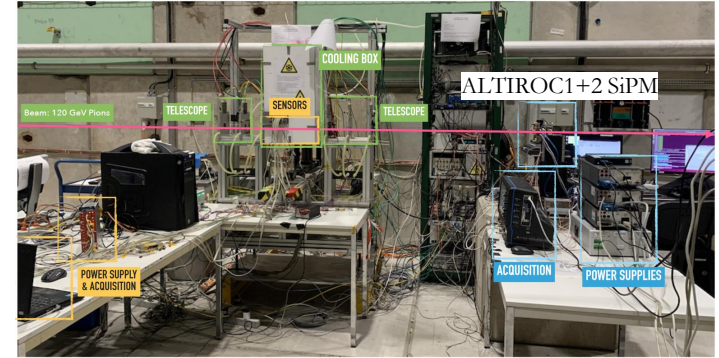

Known from fit of time difference histograms

$$\left\{ \begin{array}{l} \sigma_{\Delta T}(\text{SiPM1, SiPM2}) = \sigma_{\text{SiPM1}} \oplus \sigma_{\text{SiPM2}} \\ \sigma_{\Delta T}(\text{module, SiPM1}) = \sigma_{\text{module}} \oplus \sigma_{\text{SiPM1}} \\ \sigma_{\Delta T}(\text{module, SiPM2}) = \sigma_{\text{module}} \oplus \sigma_{\text{SiPM2}} \end{array} \right.$$

Want to determine

ALTIROC1+LGAD+test board installed in the low temperature chamber

TOT-TOA coupling caveat

- TOA-TOT is expected to be flat but it's not. This is attributed to a digital coupling synchronized with the 40 MHz clock.
- This degrades timing performance
- Since we record pulses from preamplifier probe can see why TOT depends on TOA from average pulses

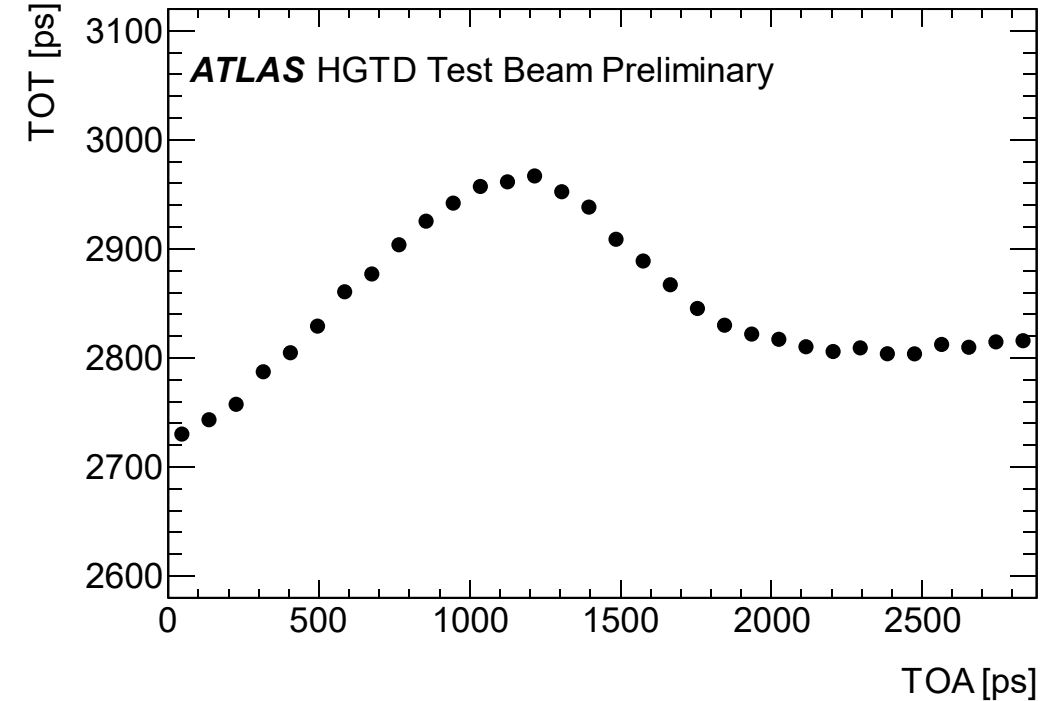
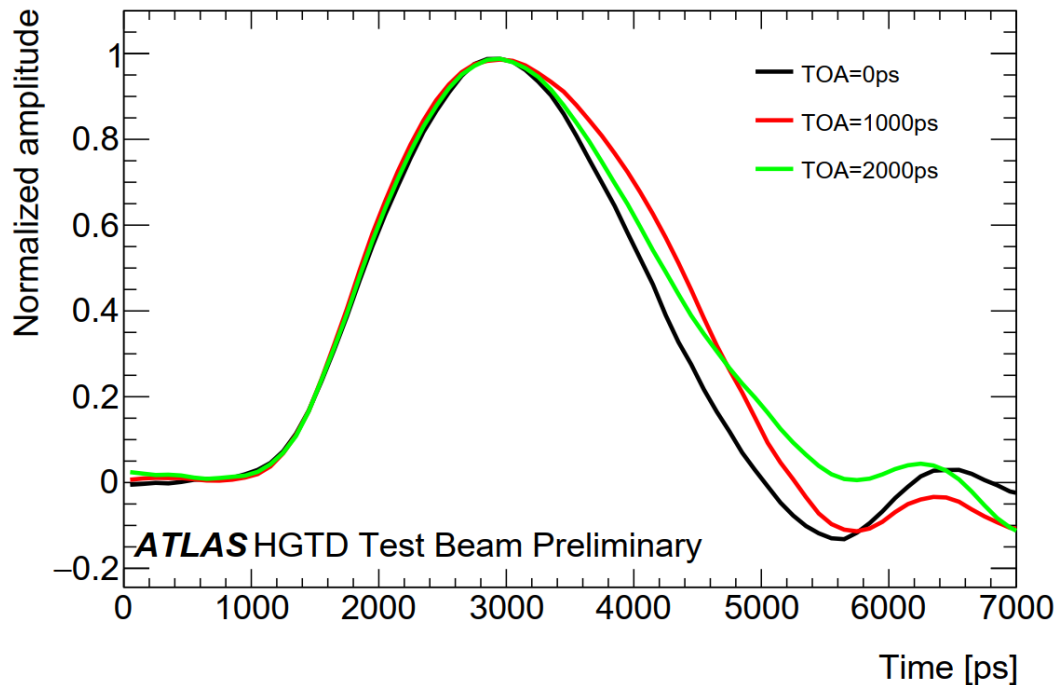

Timewalk

- ⌚ Timewalk is one of the effects degrading the time resolution
- ⌚ It can be mitigated if signal amplitude is known
- ⌚ In ALTIROC prototypes have: probe amplitude (debug feature), TOT,...
- ⌚ Example of probe timewalk for $\Delta_t(\text{module}, \text{SiPM1})$
- ⌚ Correcting (for example with fit) means making Δ_t flat

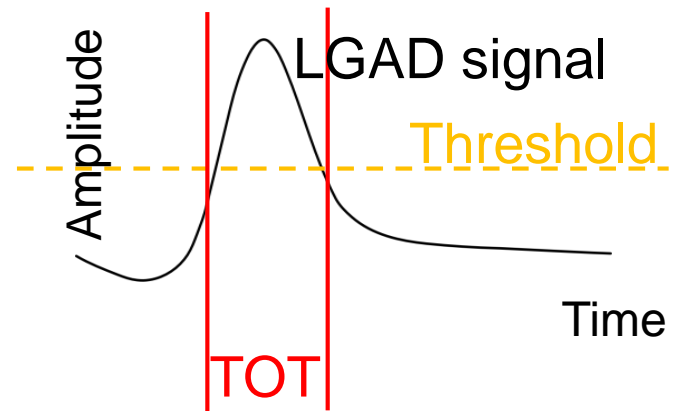
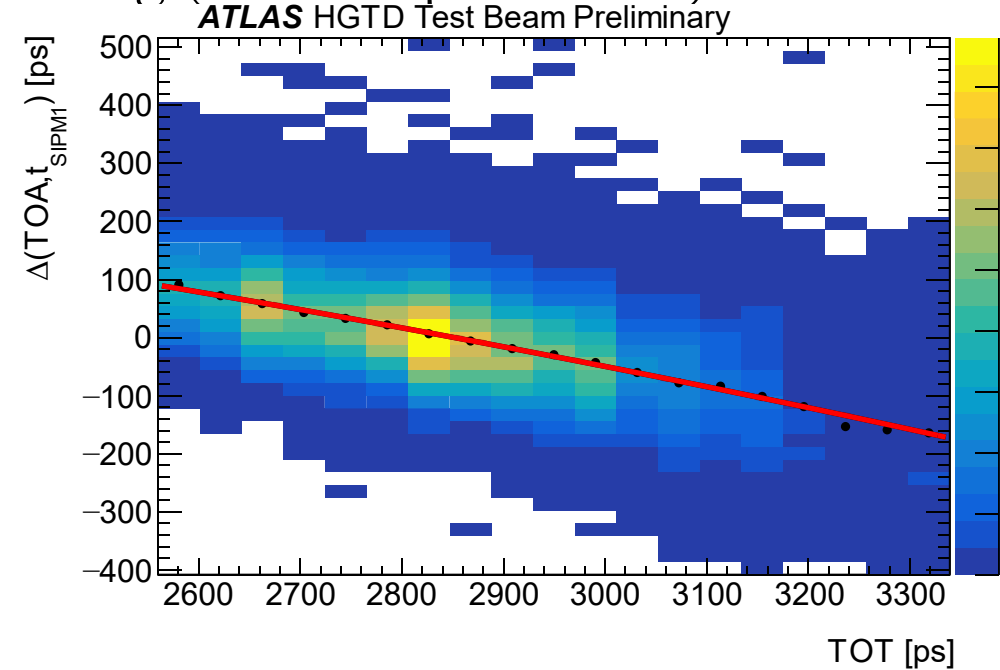
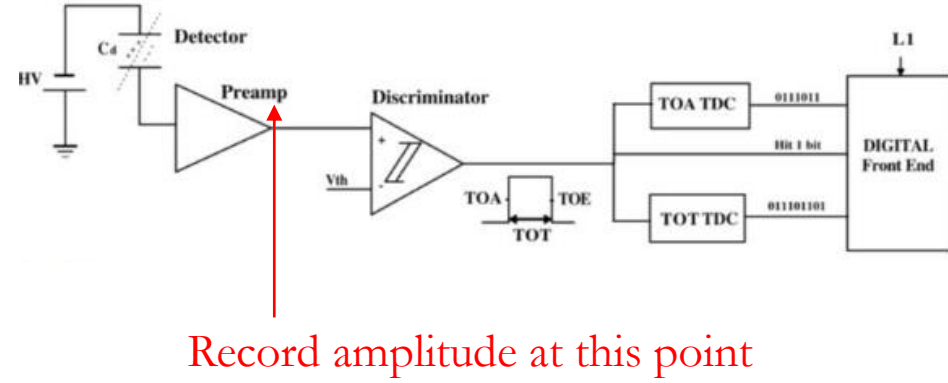
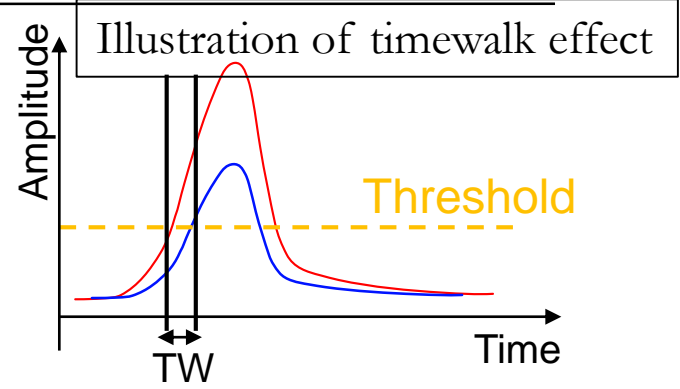

Module time resolution

- 40.3 ps with probe amplitude timewalk correction (will not be available in final detector)
- 46.3 ps with TOT timewalk correction, in the region where TOA-TOT is flat (TOA > 1600 ps)
- Then residual timewalk can be estimated as 23 ps instead of required 10

Probe is our best estimate of amplitude so it's expected that using it gives better result

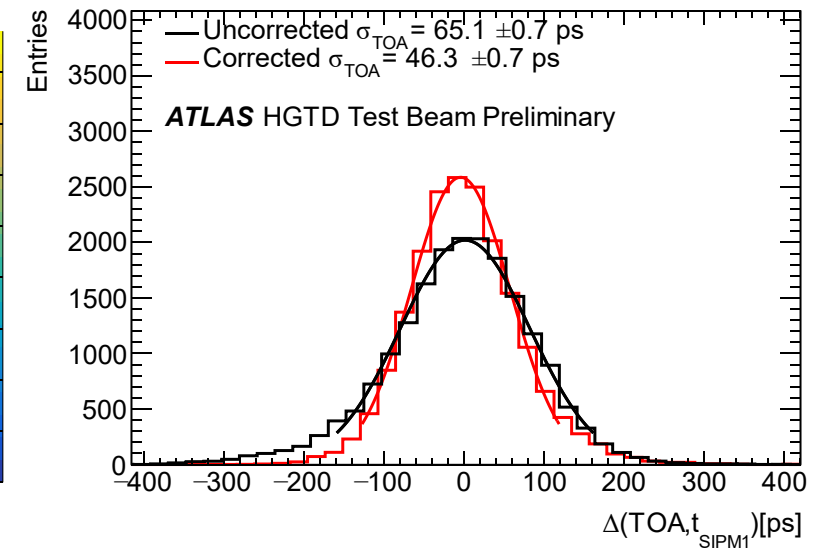
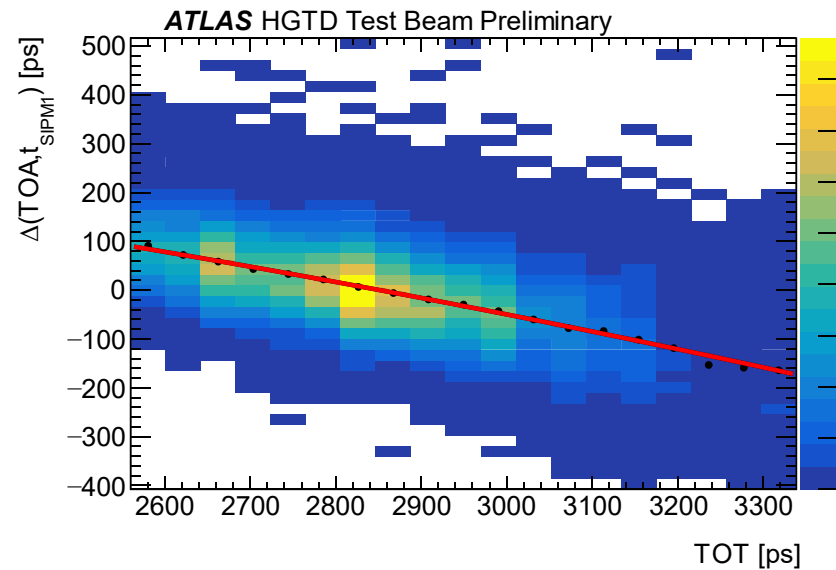
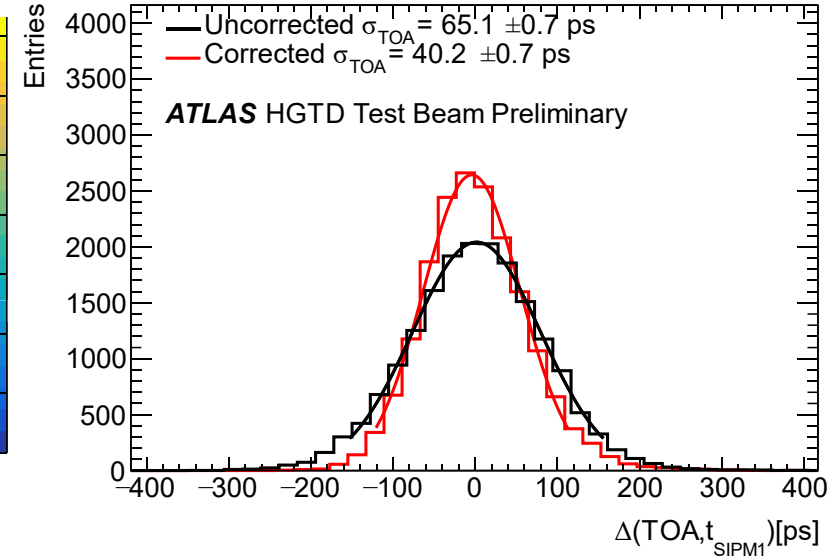
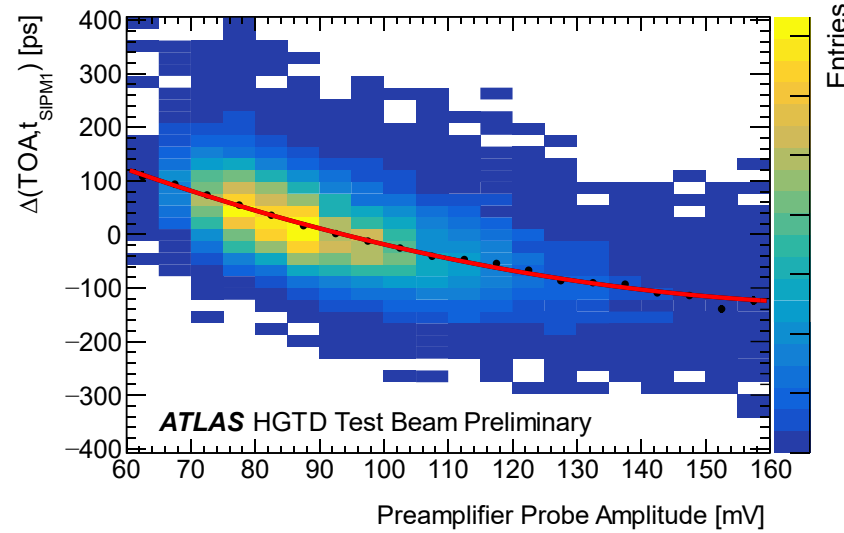

Part 4: ALTIROC2+sensor module tests

- ALTIROC2 testbeam setup is similar to ALTIROC1 except that instead of two reference SiPMs, a single MCP-PMT with negligible time resolution was used
- Now, no need to solve the 3x3 equation system, instead do

$$\Delta t = -\text{TOA} \cdot \text{LSB} - (t_{\text{MCP}} - t_{\text{clock}})$$

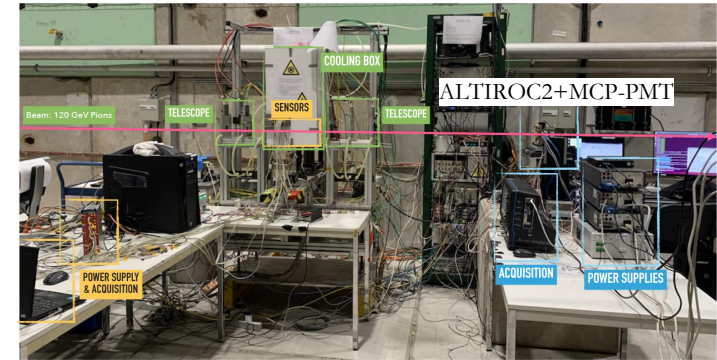

ALTIROC2+LGAD+test board

Setup:

- Room temperature
- ~half of ASIC pixels activated
- Sensor bias voltage is -180 V corresponding to a charge of ~ 20 fC
- ASIC threshold 4.8 fC
- The EUDET telescope is used for track reconstruction
- Standalone reconstruction software used

• Efficiency map measured as ratio of the reconstructed tracks with a hit seen in ALTIROC to all the reconstructed tracks penetrating the sensor area

• 100% hit efficiency demonstrated for full-size module

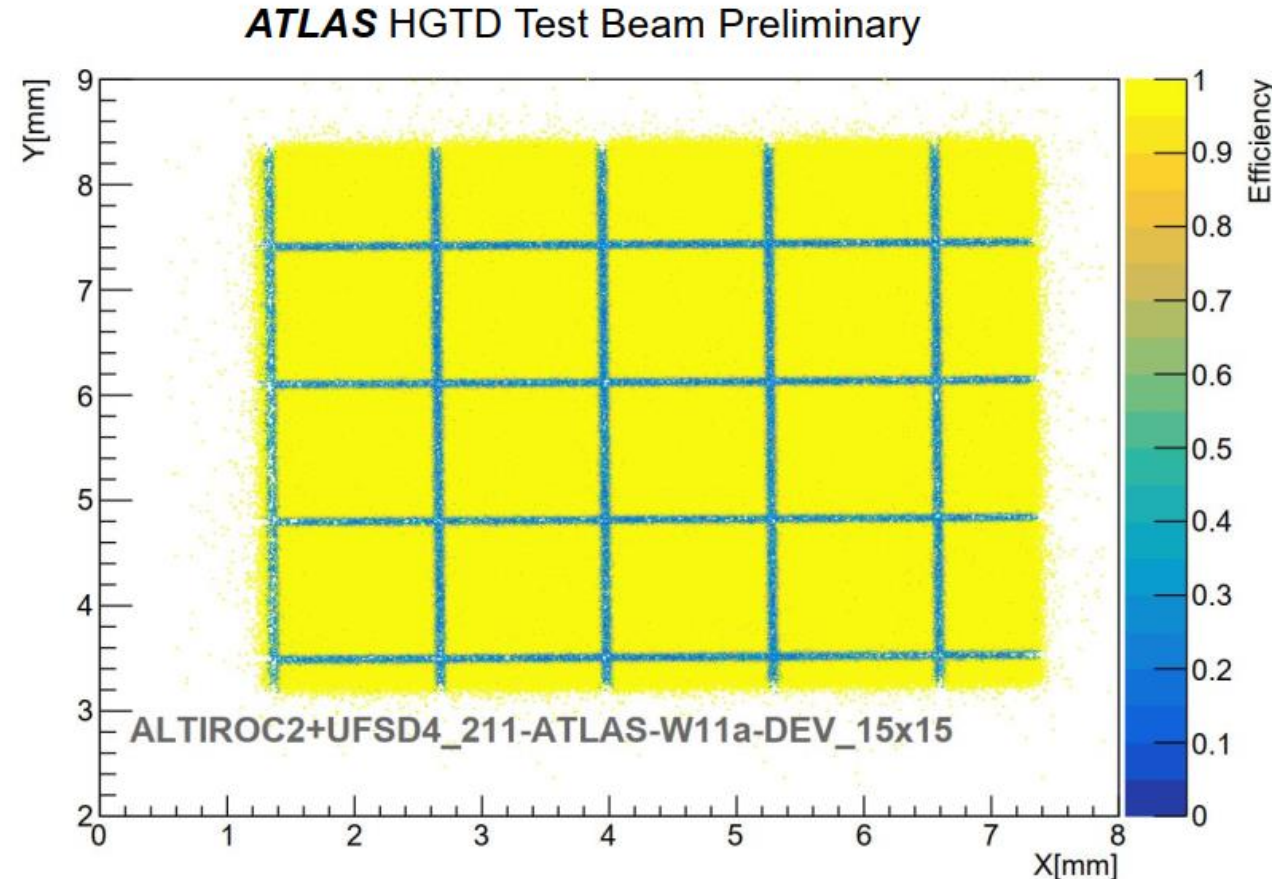

- Zoom into each vertical, horizontal gap
- Take 50 % width as definition of width, get it from linear interpolation
- Sizes of gaps are reasonably uniform
- Nominal is $49 \mu\text{m}$

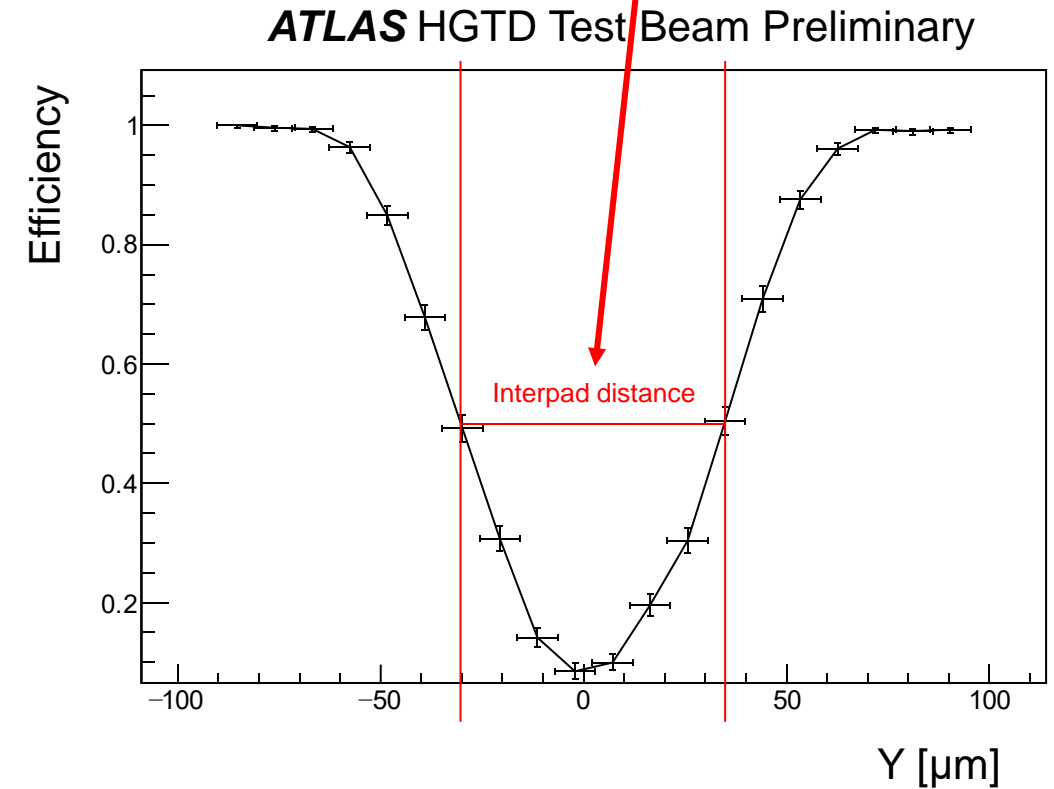
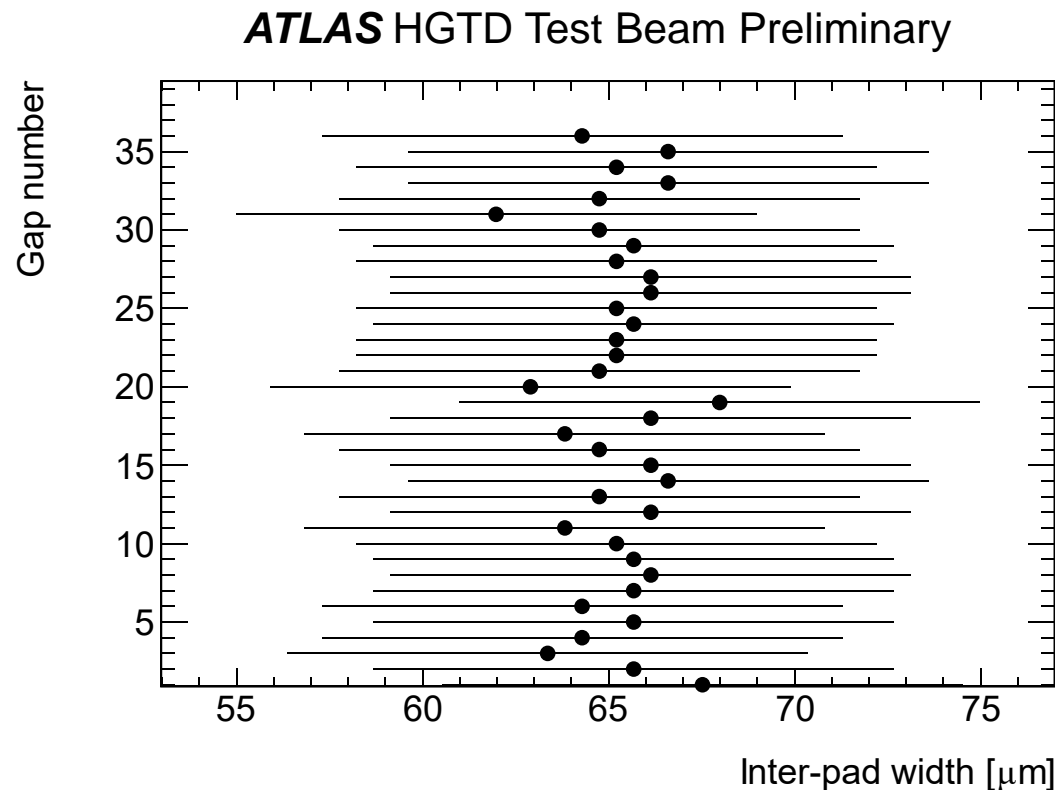
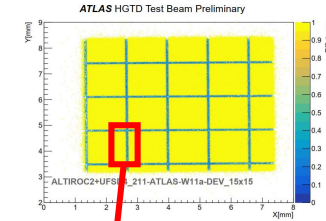

- ⌘ Radiation tolerant LGADs testbeam performance meets the requirements: charge collected, time resolution, efficiency.
- ⌘ ALTIROC1+LGAD module (small-size ATLAS HGTD ASIC prototype mounted on the sensor) demonstrated in Test Beam the capability to provide timing information with resolution 40.2 ± 0.4 ps, which is close to the requirement. However, part of the information not available in the final chip was used. With ASIC-only information, the resolution is 46 ps.
- ⌘ ALTIROC2+LGAD full-size module showed 100% hit efficiency in Test Beam, as required.
- ⌘ 50%-50% size of interpad regions is extracted from efficiency maps and equal to 65.3 ± 0.2 μm .

The End

Backup ↓

Why hgtd only in forward region

Tracker is good enough

<https://cds.cern.ch/record/2851661/files/ATL-HGTD-SLIDE-2023-015.pdf>

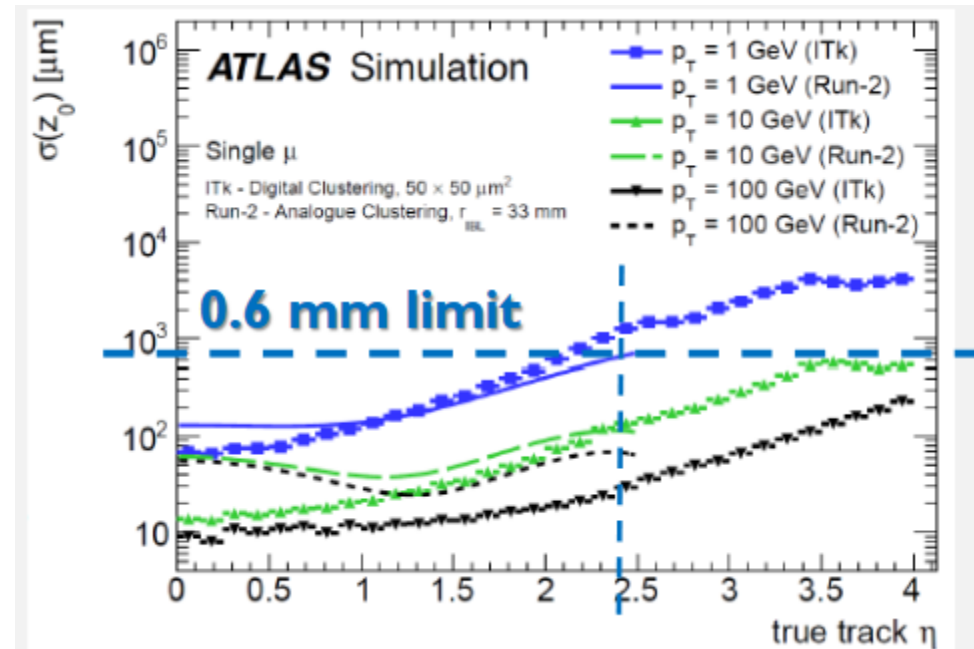

Sensors replacement scheme

- 🕒 The closer to the beam the higher the fluence
- 🕒 Sensors only able to survive outer later fluence therefore
 - 🕒 inner ring sensors replaced every 1000 fb⁻¹
 - 🕒 middle ring sensors replaced at 2000 fb⁻¹.
 - 🕒 Outer ring never replaced (42% of HGTD)

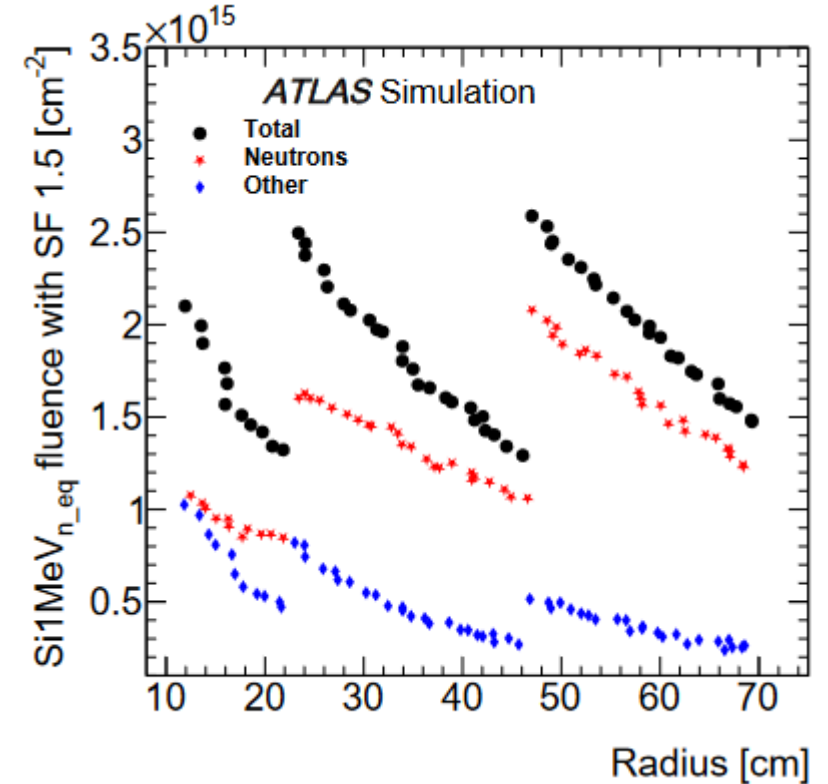
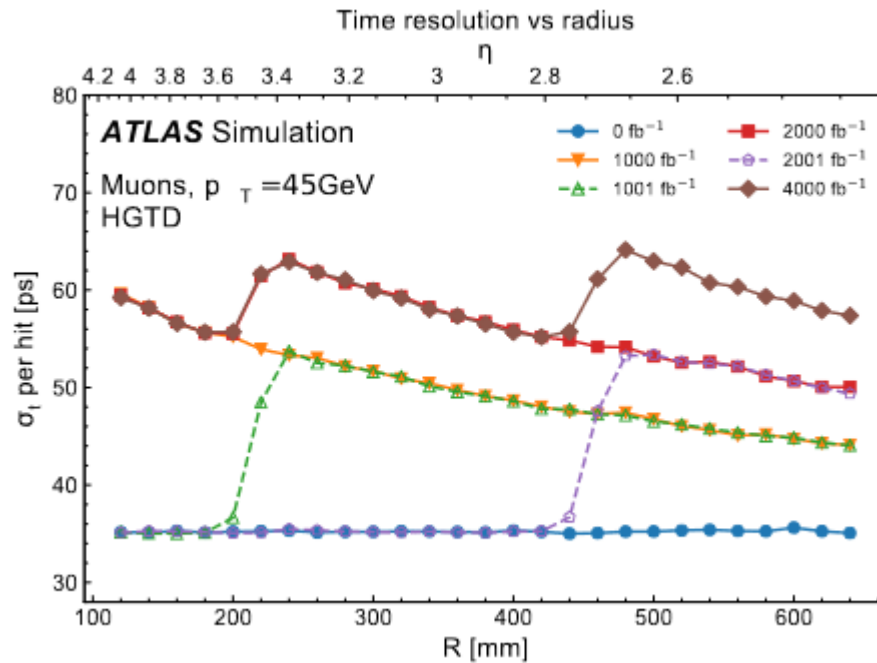

- ❗ Sensor must be thin to minimize landau fluctuations.
But it cannot be too thin because this will drive the capacitance. Optimal thickness $\sim 50\mu\text{m}$
- ❗ LGADs are n-on-p silicon detectors with an additional p-type doped layer containing charge multiplication to achieve an internal gain
- ❗ Gain must be low because otherwise noise grows

$$\sigma_j = \frac{\sigma_n}{\left|\frac{dV}{dt}\right|} \approx \frac{\sigma_n}{\left|\frac{S}{\tau_p}\right|} = \frac{\tau_p}{S/N}$$

