

IJCLab Orsay, France 19-22 June 2023

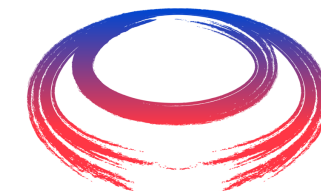

Funded by
the European Union



International
UON Collider
Collaboration

Final Cooling Solenoid

B. Bordini, C. Accettura, A. Bertarelli, L. Bottura,
A. Dudarev, A. Kolehmainen, T. Mulder,
B. A. Verweij, M. Wozniak

2nd IMCC Annual Meeting

The Cooling System

Muon Collider (Muon Accelerator Staging Study)

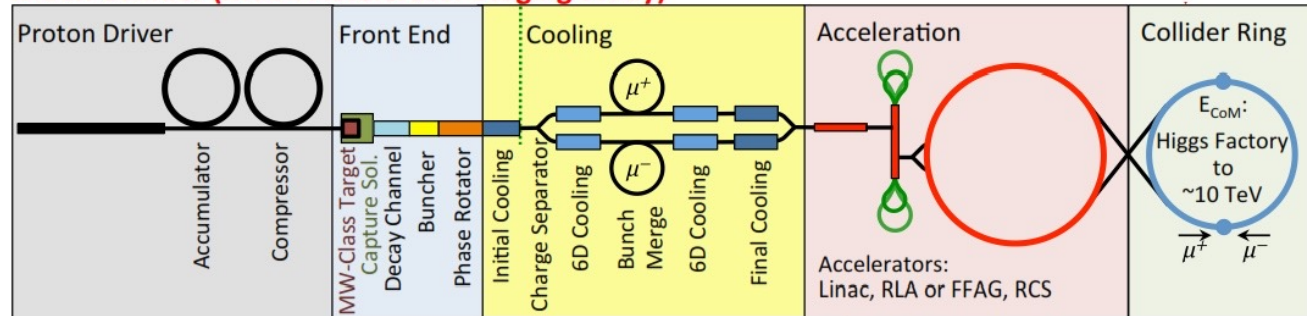

- The **final cooling solenoid** is part of the **cooling system**

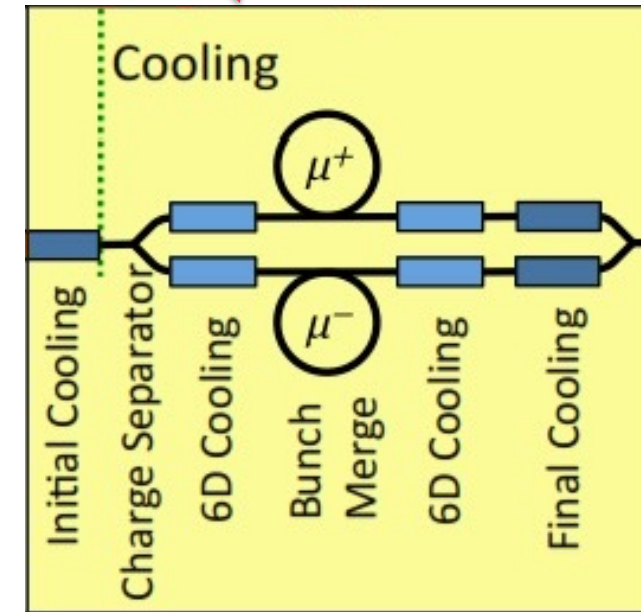

- The cooling system is designed to **reduce** the **transversal emittance** while **preserving** the **longitudinal emittance**

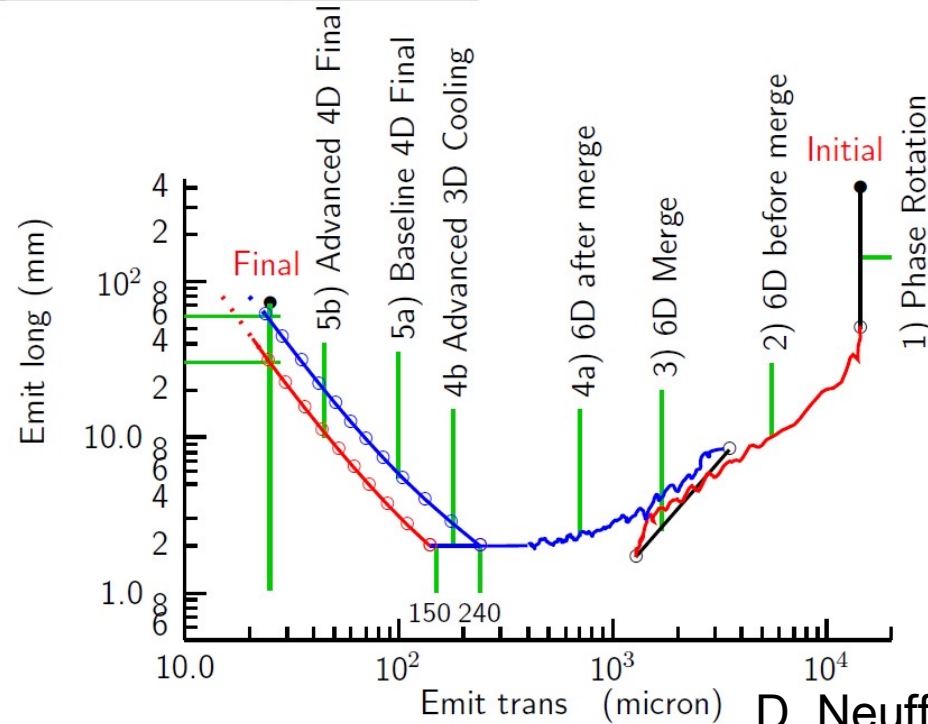

D. Neuffer et al 2017 JINST 12 T07003

The Final Cooling Channel

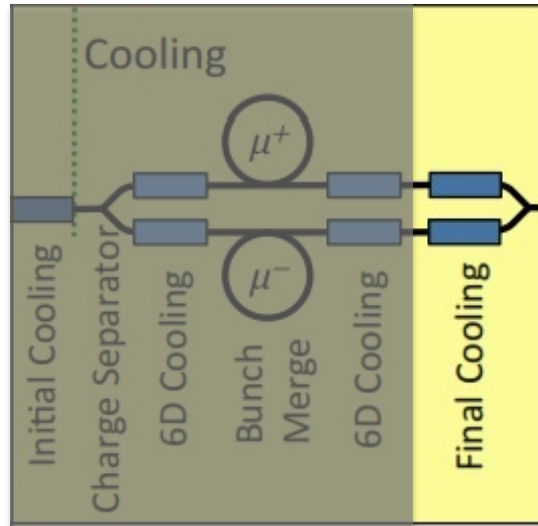

- In particular, the **final cooling solenoids** are part of the **final cooling channel**, which is constituted by **several cells**
 - 16** were proposed by the MAP study
 - 14** are presently considered by IMCC

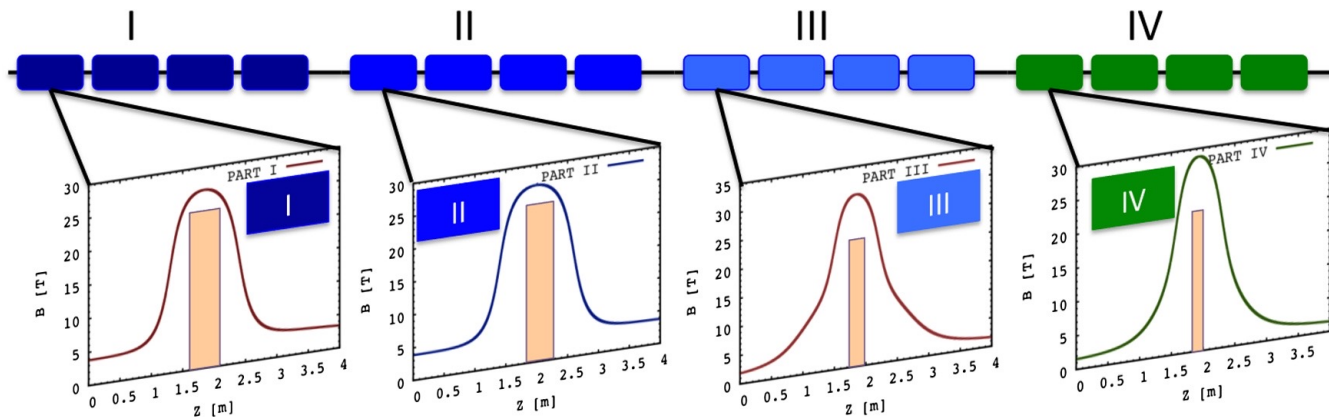

4 σ beam dimensions and kinetic energies
Courtesy of Elena Fol

Cell	Aperture [mm]	LH [cm]	$E_{kin, start}$ [MeV]	$E_{kin, exit}$ [MeV]
1	25	74	67	36
2	22	64	70	46
3	21	59	68	43
4	21	62	62	36
5	21	55	66	44
6	19	56	58	33
7	19	53	55	31
8	19	44	43	19
9	20	40	41	19
10	19	38	32	5
11	24	23	32	14
12	14	22	29	7
13	18	18	26	4
14	18	17	23	4

A layout schematic of 16 cells of the final cooling channel defined by the MAP study (Sayed et al. Phys. Rev. ST Accel. Beams **18**, 091001). The coloured boxes in the top represent the cooling cells. The bottom figures show a sample of the on-axis field of the strong focusing solenoid; the shaded areas show the corresponding absorbers lengths.

The Ionizing Cooling Cell

- **Each cell** starts with a strong focusing **final cooling solenoid** enclosing the LH₂ absorber
- The final cooling solenoid is followed by matching coils, energy-phase rotation rf cavities, and acceleration rf cavities
- The **final cooling solenoids** have been identified as the **critical components** the **final cooling section**

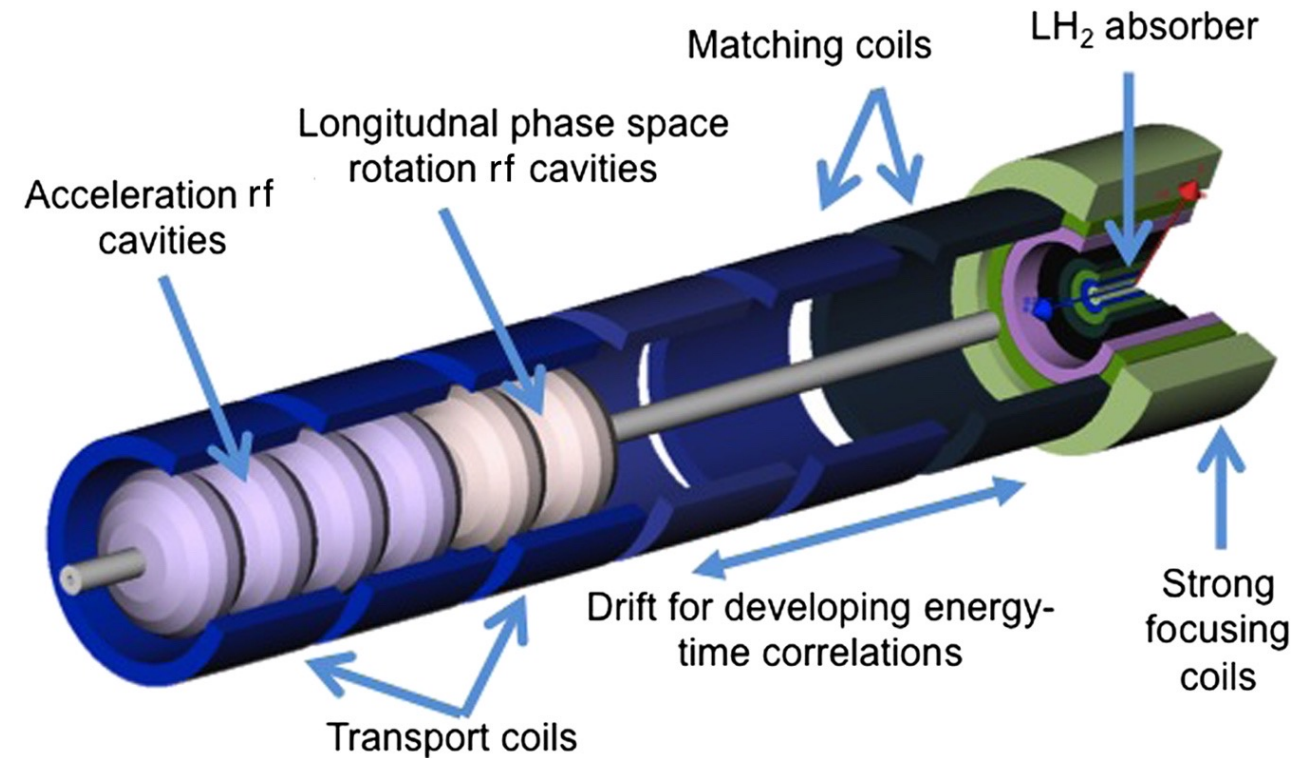

Schematic of the elements of one ionization cooling cell, Sayed et al. Phys. Rev. ST Accel. Beams **18**, 091001

The Final Cooling Solenoid

Design proposed by MAP

Magnet length [m]	Inner radius [m]	Coil thickness [m]	Current density I/A [A/mm ²]
0.317	0.025	0.029	164.26
0.337	0.055	0.041	142.43
0.375	0.098	0.056	125.88
0.433	0.157	0.067	119.07
0.503	0.228	0.120	85.99
0.869	0.355	0.089	39.60
0.868	0.454	0.104	44.30
0.992	0.575	0.252	38.60

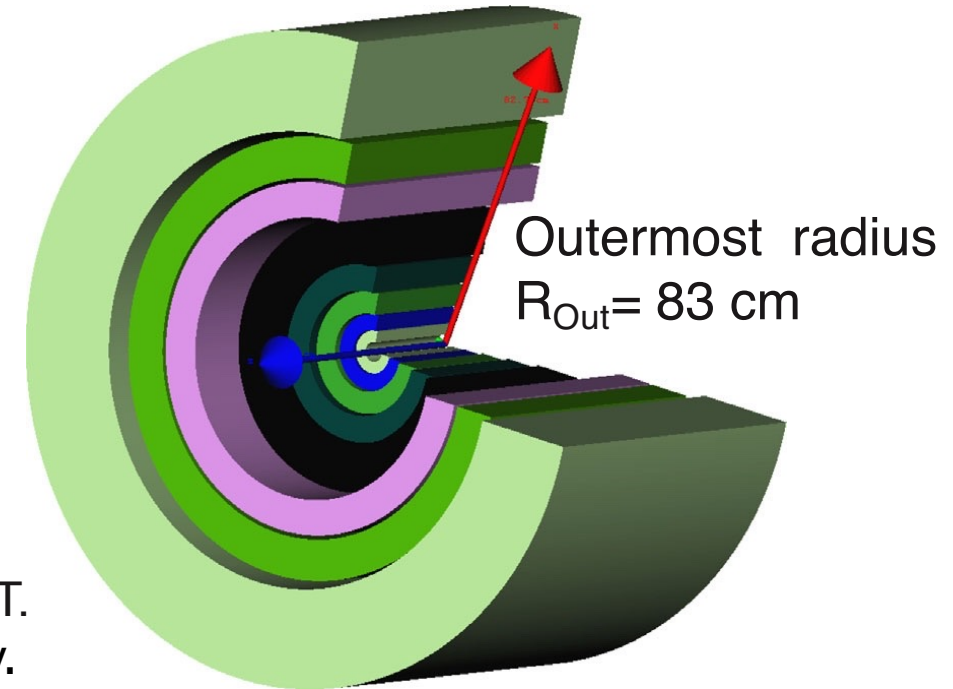

A set of eight superconducting coaxial coils providing a peak field of 50 T. The inner radius of the smallest coils is 0.025 m. Sayed et al. Phys. Rev. ST Accel. Beams **18**, 091001

- **Main specs** used for the CERN conceptual design
 - **$B \geq 40$ T**, aperture **$\phi \geq 50$ mm**, field **homogeneity 1 %** over **~ 0.5 m**
 - **Energizing time 6 hrs** and **persistency 0.1 Units/s**

State of the Art Ultra High Field Hybrid Solenoid Superconducting + Resistive

<https://nationalmaglab.org/user-facilities/dc-field/magnets-instruments/>

http://english.hmfl.cas.cn/uf/ms/202202/t20220224_301451.html

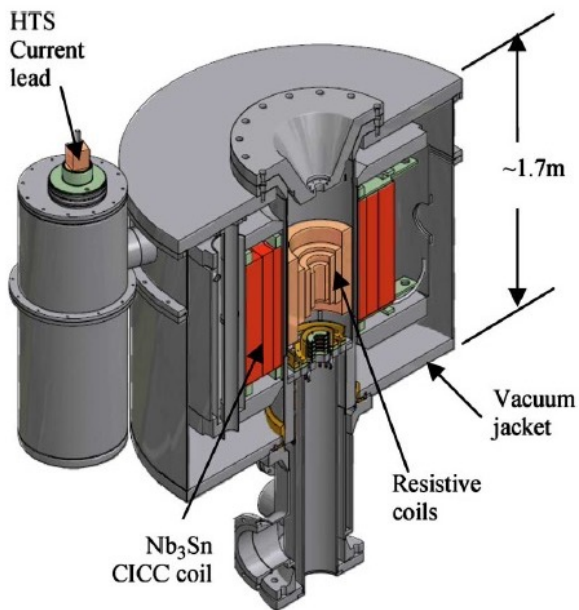

Tallahassee magnet system.

Cross section of **45 T, 32 mm NHFML** user facility solenoid Hybrid Magnet 33.5 T from resistive insert, 11.5 T by superconducting outsert
30 MW power consumption

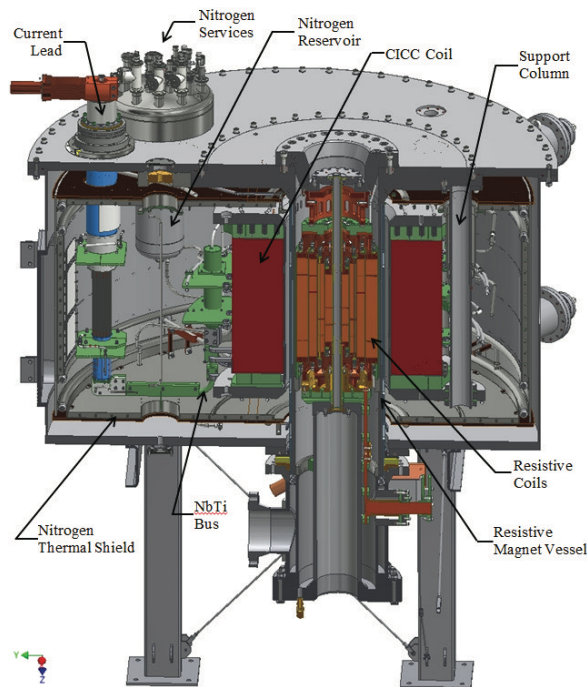

Cross section of **36 T, 48 mm NHFML** user facility (NMR) solenoid Hybrid Magnet 23 T from resistive insert, 13 T by superconducting Nb₃Sn CICC outsert
14 MW power consumption

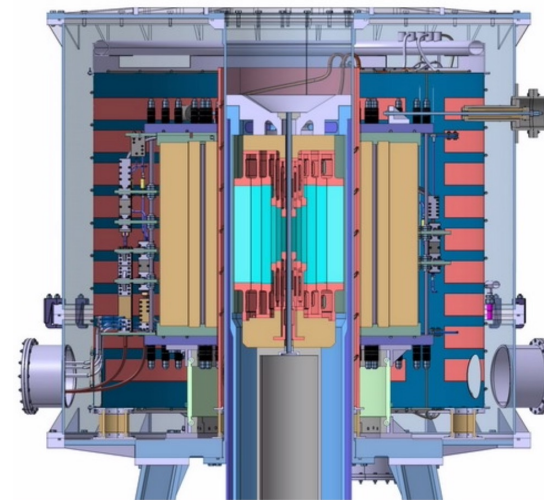

Cross section of **40*/37 T, 32/50 mm CHMFL** user facility solenoid Hybrid Magnet 29/26 T from resistive insert, 11 T by superconducting Nb₃Sn CICC outsert
20 MW power consumption

State of the Art Ultra High Field Hybrid Superconducting Solenoids

Cross section of **32 T** (15 T LTS, 17 T two ReBCO double pancake coils), **32 mm** user facility solenoid

<https://nationalmaglab.org/user-facilities/dc-field/magnets-instruments/>

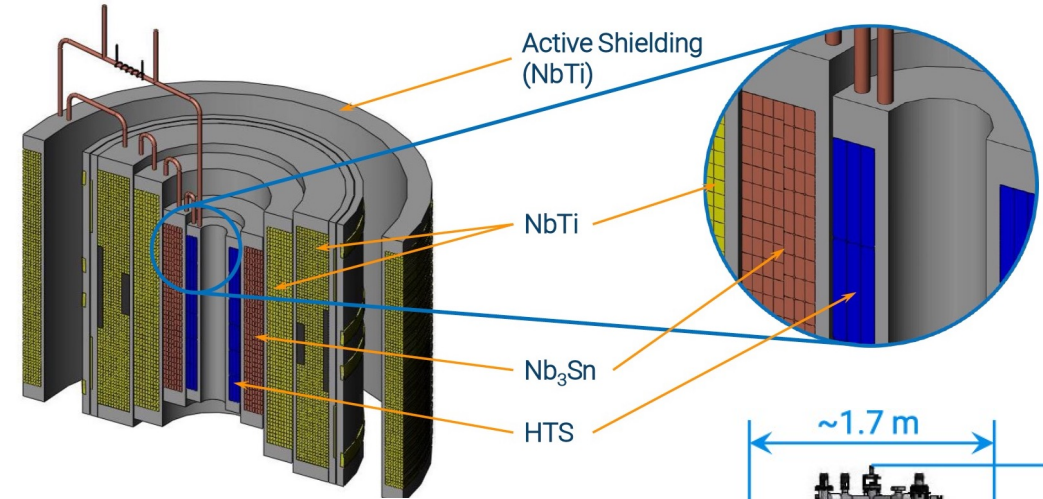
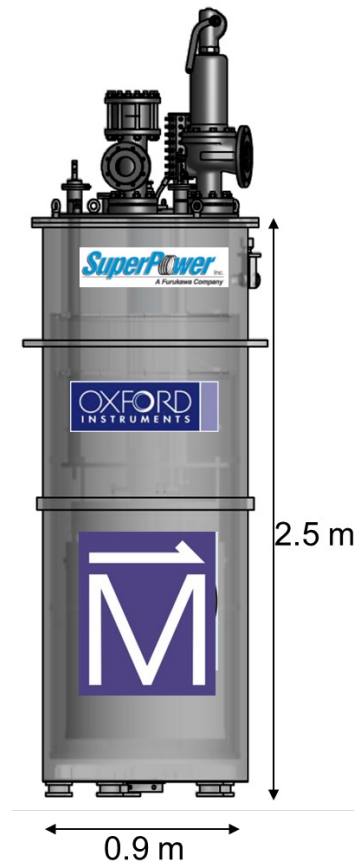
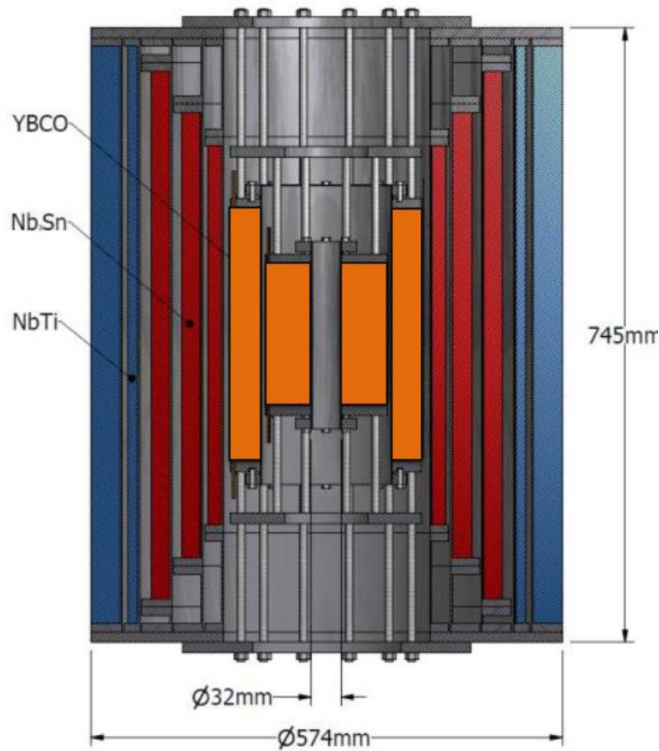

Artistic impression of a UHF NMR magnet by Bruker:
1.2 GHz-NMR (Bruker)

28.19 T – 54 mm RT

<https://snf.iewecsc.org/sites/iewecsc.org/files/documents/snf/abstracts/MT27%20PL1%20Bruker%20High%20Field%20NMR.pdf>

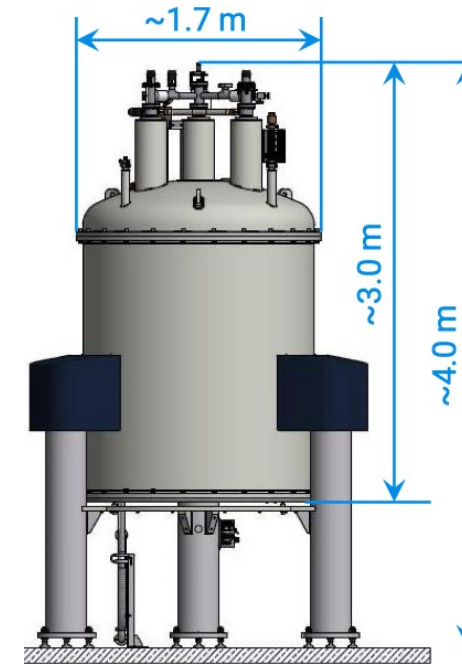

Why state of the art Ultra High Field UHF Hybrid solenoids are so big?

- In a solenoid, the **hoop stresses** are **proportional** to the **Magnetic Pressure** ($P_M \equiv \frac{B_0^2}{2\mu_0}$)
 - For **not supported** infinitely long **solid coil** with a **uniform current density**, the **maximum hoop stress** is
 - **~2.2 P_M** when $\alpha \equiv R_{ext}/R_{int} = 1.85$
 - **~1.4 P_M** when $\alpha \gg 1$
 - For **not supported** infinitely long **coil** with a **uniform current density** and **windings not mechanically interacting radially**, the **maximum hoop stress** is
 - **~2.2 P_M** when $\alpha = 1.85$
 - **~0.9 P_M** when $\alpha = 4$
 - **~0.5 P_M** when $\alpha \gg 1$
- Because P_M is enormous and to limit the stresses one natural solution is to dilute the current and decouple as much as possible the windings

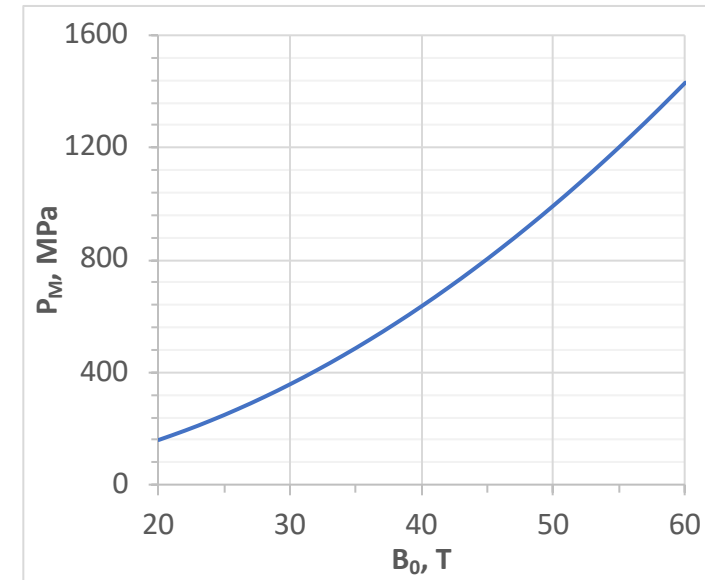

Yield strength of

1. annealed oxygen free copper:
30-80 MPa (grain size 50-3 μm)
2. austenitic steel 316LN SS:
270 MPa at RT (830 MPa at 4 K)

UHF Superconducting Solenoids

Next step for nested coils

- The design of superconducting solenoid by using **nested insulated coils** proved to be **successful** in producing **~30 T** magnets with **apertures** up to **5 cm**
 - This concept will be **further investigated** and perfected by **ongoing projects** that try to optimize it and to reach **larger field** values
- While this design is **suitable** for **user facilities**, it is **not clear** it could **satisfy** the **needs** of the **final cooling solenoids**

Cartoon design of 40 T, 32 mm user facility solenoid (planned) – Courtesy of Ian Dixon NHMFL

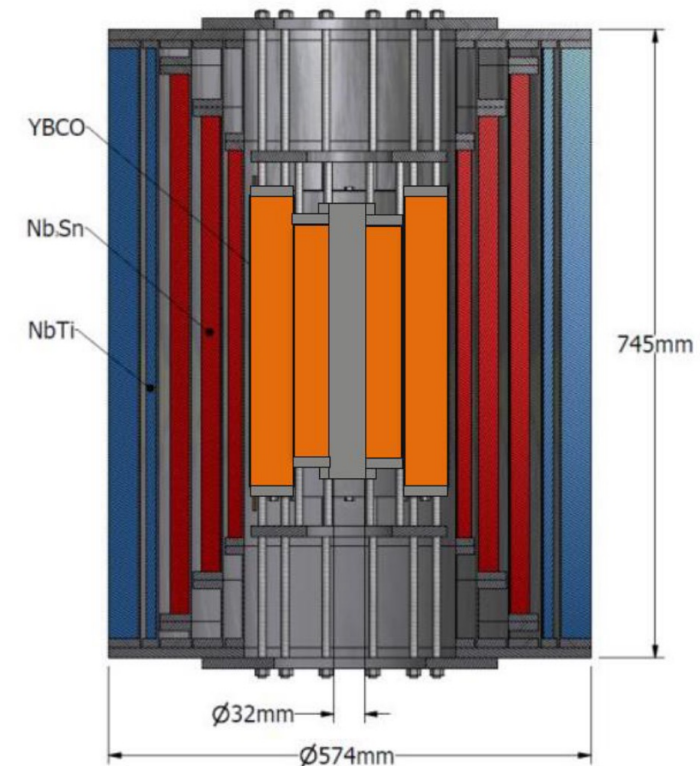



UHF Superconducting Solenoids

Nested Coils & Final Cooling Solenoid



- The **nested coil design** presents **some drawbacks** that might be **problematic** for the **final cooling solenoids**
 - **Diluting the current** over large coil cross section (low J)
 - requires a larger **amount of superconductor (cost)**: the current lines are not compacted around the magnet aperture
 - Implies a larger **magnetic energy** stocked, which makes the magnet protection more complex, and larger sizes
 - The magnet **protection**, which is critical in magnets using HTS, is rather complex because of the **interactions** between the different **nested coils**
 - The presence of **several coils** and **components** could make the **construction** more **difficult** and the magnet system **less reliable**
- And if we go to the **opposite direction? High uniform J** ($>400 \text{ A/mm}^2$) in a single coil (\rightarrow low α) ? So far, we said that low α makes explode the hoop stress, but...

UHF Superconducting Solenoids

Single coil, High- J_e

- This **concept** was proved **successful** for a **Not Insulated ReBCO winding** that reached **26.4 T** with a maximum **hoop stress** of **286 MPa**
- But we **need** much **larger fields** (>40 T) and the hoop **stress** is **proportional** to B_0^2
- **Plus**, at larger fields, **tensile radial stress** appears, which is **not acceptable** for ReBCO tapes, **what** can we **do**?
 - **Support** externally **the coil** with **stiff rings** that also apply a **precompression** to the coil

Sunam NI one-body ReBCO magnet
 26.4 T in 35 mm, J central pancake
 404 A mm⁻² (26.4 T HTS multi-width)
 overall diameter and height:
 172 and 327 mm

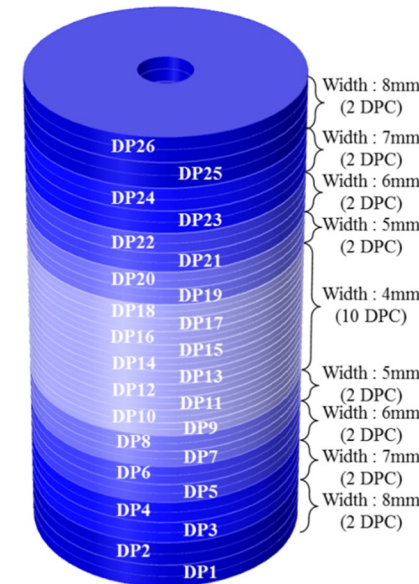
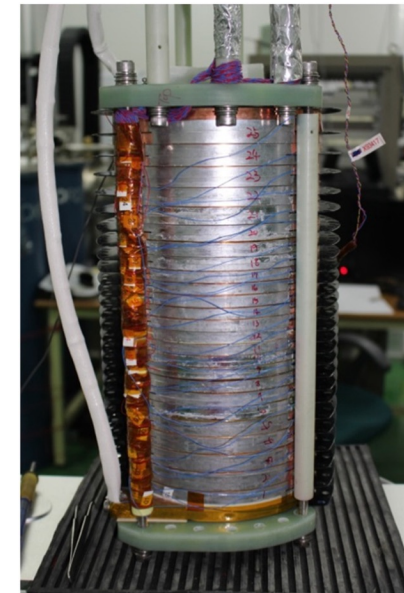

S. Yoon et al. Supercond. Sci. Technol. 29 (2016) 04LT04

Electro-mechanical Properties of the ReBCO tape

- For a **12 mm wide tape**, we can assume critical current I_c values of this level
 - Measured² at 4.2 K: $I_c (B_{\perp}=15 \text{ T}) \sim 1.8 \text{ kA}$;
 $I_c (B_{\parallel}=15 \text{ T}) \sim 5.4 \text{ kA}$
 - Estimated at **4.2 K**: $I_c (B_{\perp}=50 \text{ T}) \sim 300 \text{ A}$;
 $I_c (B_{\parallel}=50 \text{ T}) > 1000 \text{ A}$

<Schematic of RE-based HTS tape>

Stabilizer [Cu plating] 20 μm
 Protection layer [Ag] 2 μm
 Superconducting Layer
 Buffer layer [MgO, etc.] 0.7 μm
 Substrate [Hastelloy®] 50 μm

[EuBCO+BHO] 2.5 μm

Sketch taken from ref. 1

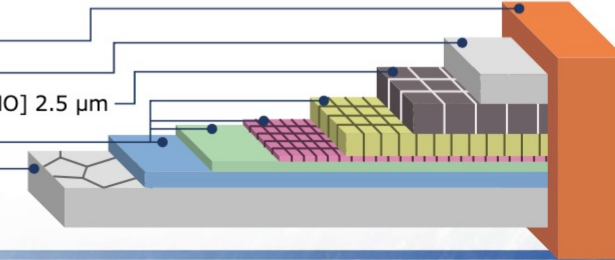

¹<https://www.fujikura.co.jp/eng/products/newbusiness/superconductors/01/superconductor.pdf>

² Shinji Fujita, Satoshi Awaji et al. IEEE TAS, VOL. 29, NO. 5, AUGUST 2019

³ Hideaki Maeda and Yoshinori Yanagisawa IEEE TAS, VOL. 24, NO. 3, JUNE 2014

Mechanical stresses producing irreversible I_c reduction

- Tensile longitudinal strain** $> 0.4 \%$ ¹ (600-800 MPa depending on the Hastelloy fraction)
- Compressive** stress in **thickness** direction $> 400 \text{ MPa}$ ¹
- Compressive** stress in **width** direction $> 100 \text{ MPa}$ ¹
- Tensile** stress in **thickness** direction: 10-100 MPa³
- Shear** stress $> 19 \text{ MPa}$ ³
- Cleavage/Peel** stress³ (tensile at tape extremities) $< 1 \text{ MPa}$ ³

Picture taken from ref. 3



40+ T Conceptual design

- **46** identical **'modular'** and **6 'correction'** pancakes
- **'modular'** pancake:
 - **6 cm (6-8) thick** coil
 - J_e **632 A mm⁻²** (>500)
 - **12 mm wide tape**
 - **Outer ring** thickness x times (>1) coil thickness
 - Inner ring 5 mm thick
 - Support Plate 2 mm (less?) thick
 - Bore **aperture 50 mm**
 - Bore Field = **40 T**

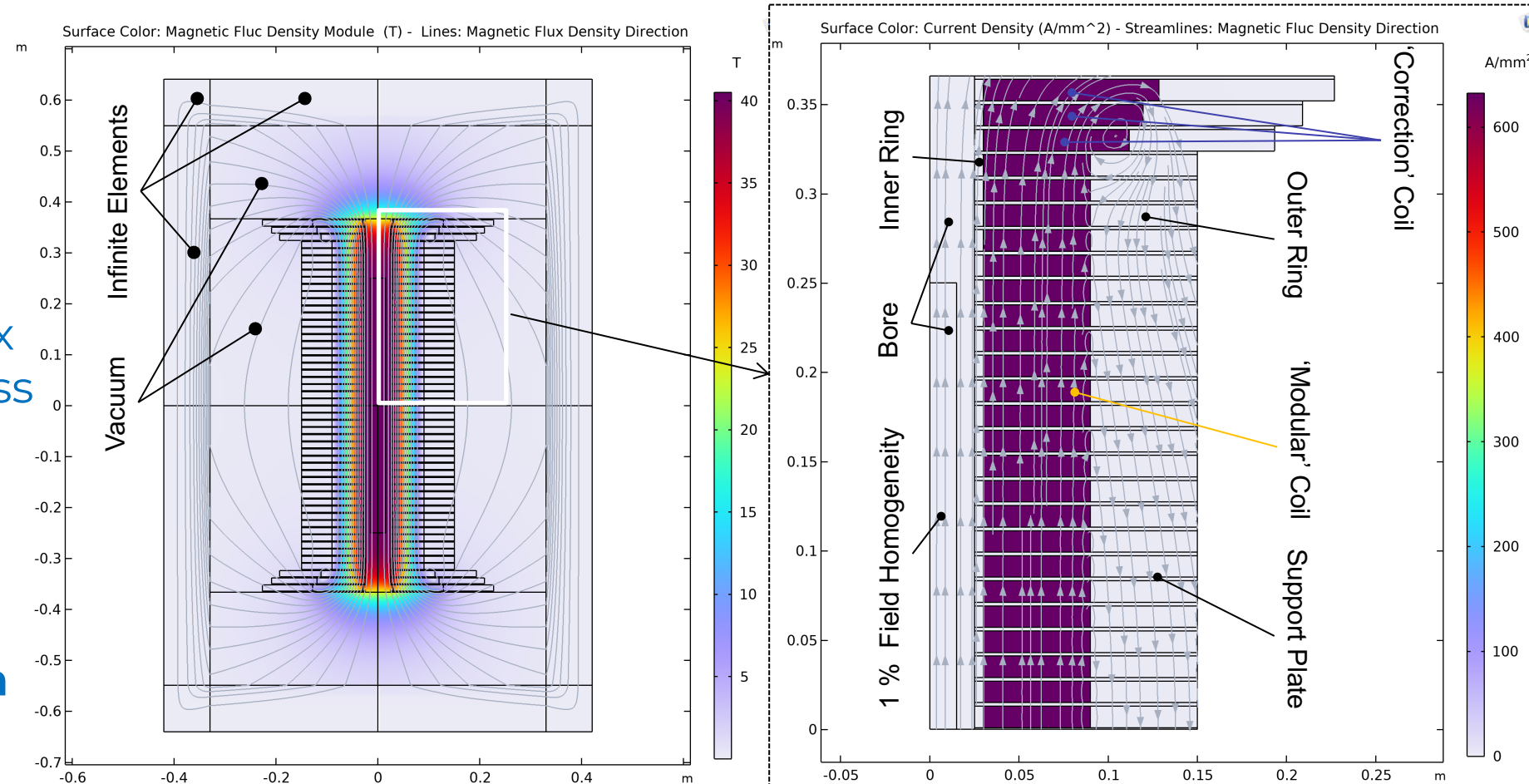

- $J_e > 500 \text{ A mm}^{-2}$
 - limit **costs** and **dimensions**
- **Modular Single coil pancakes** (not nested coils)
 - **simplify** the **design**, the magnet **system** and the **protection**
- **Non/metal insulated** coils
 - **protection**, mechanical **robustness**, high J_e
- **Avoid tensile radial stresses** and limit the **hoop strain** to values **lower** than **0.4 %**
 - **minimize** the **risk** of I_c **degradation**
- **Radially support** each pancake **via** a stiff **outer ring** that also applies a radial **precompression** on the coils
 - **limit** the **hoop strain** and **avoid tensile radial** stresses

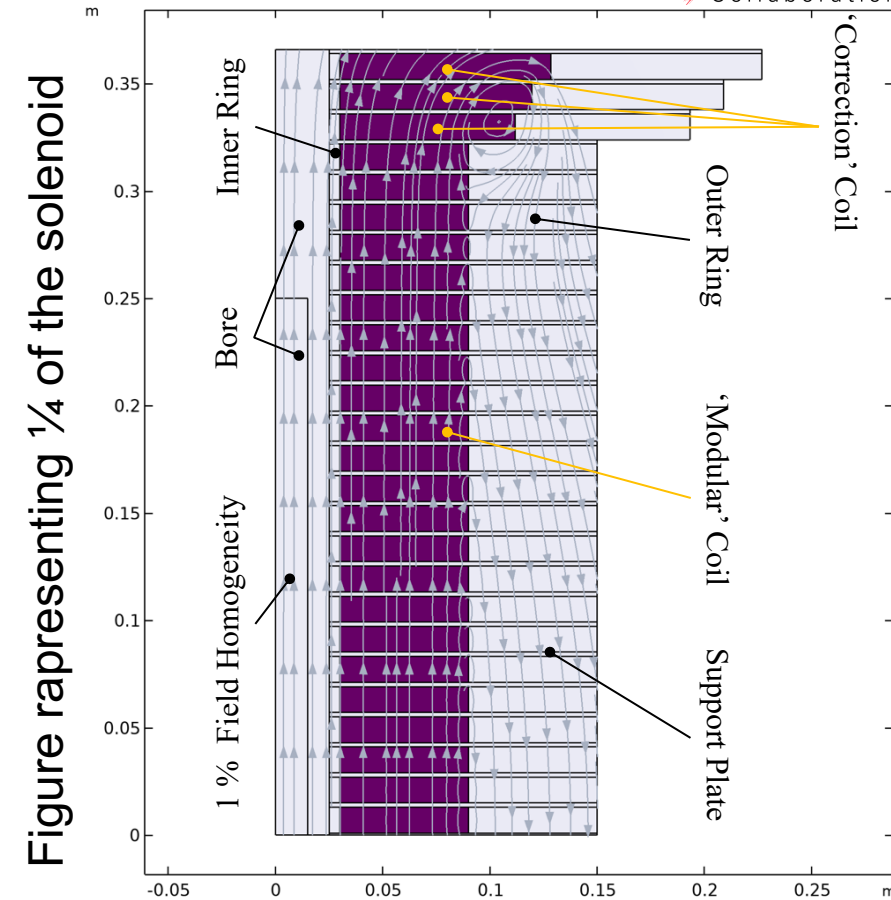

- Maintain the magnetic **field lines** practically **parallel** to the **tapes** in the **'modular'** coils
 - **minimize axial** Lorentz **forces** and **maximize I_c**
- **Intercept axial** Lorentz **forces** between pancakes via **support plates**
 - **minimize** the pancakes **mechanical interactions**, **avoid** the **accumulation** of axial forces
- Use as **wide** as possible **tapes**, 12 mm
 - to **limit** the number of **pancakes**
- **Robust design** for the **'correction'** coils, to **account** for the not negligible **axial forces** experience (significant radial fields) and the conductor **magnetization** (tape striations ?)
 - **protection**, mechanical **robustness**

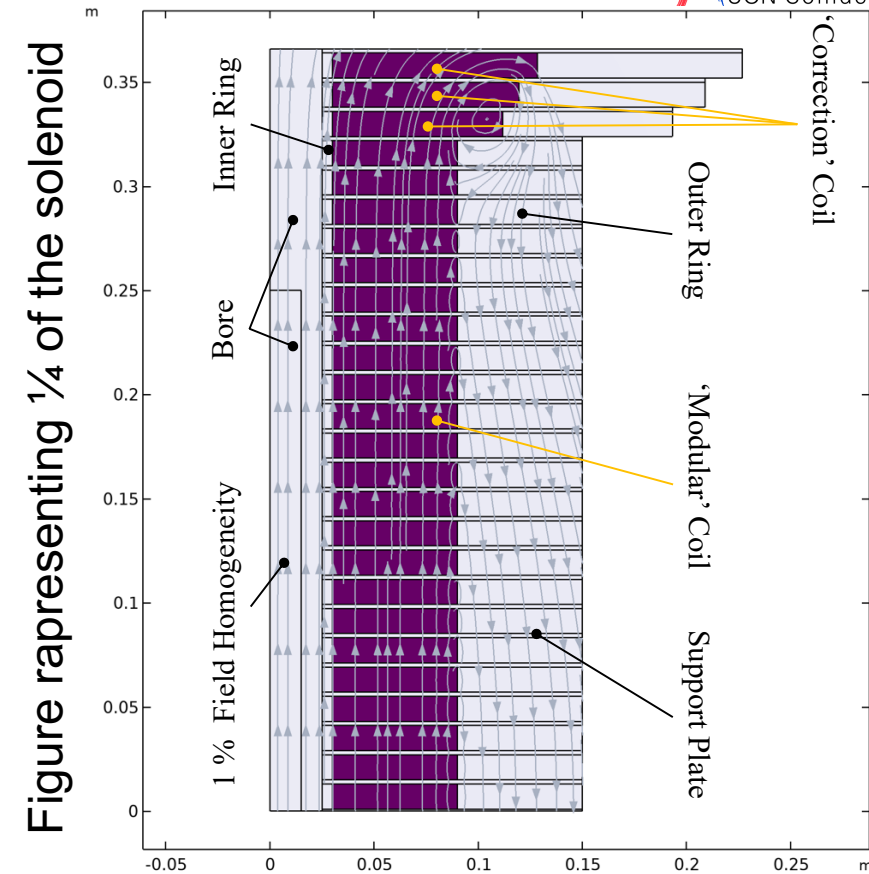

Mechanical Analysis I *

main findings

- A **precompression** of about **200 MPa** is **essential** to limit the conductor hoop stress to acceptable values
- **Even** with a **200 MPa** precompression, the coil **thickness** must be **smaller** than **~8 cm** to avoid radial tensile stress
- The **maximum field** achievable with this design (based on pancakes made of a **single coil**) is **about 40 T**
- **Most** of the **axial** Lorentz **forces** act on the **last 2 pancakes** of each extremity
 - about 3 and 1.5 MN → on average ~30 and 15 MPa applied on the respective support plates
 - the axial force acting on the 4th coil is more than one order of magnitude lower

Max Hoop stress and load line for different thickness of the modular coil winding (pre-compressed at 200 MPa)

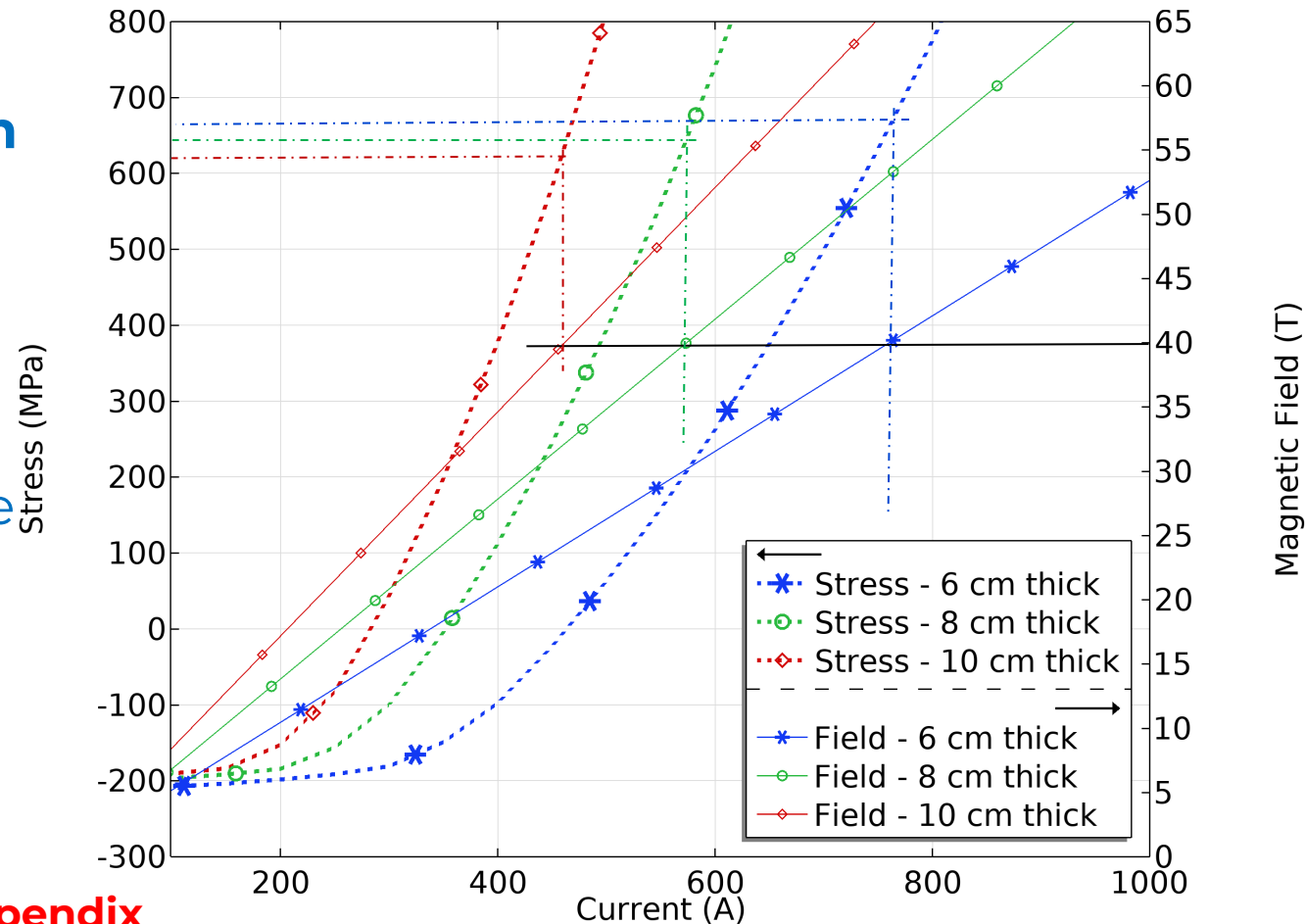

*Assumption in appendix

Mechanical Analysis II *

Case studies and main findings

- 200 MPa precompression **feasible** via **shrink fitting****

Plots refer to Case 1

- Calculated **stresses** and strains are **well below** the **limits** of the superconductor

- The **max hoop strain** strongly **depends** on the **thickness** of the **plates** between **modular** coils

- The tape **Copper fraction** does **not** significantly **impact** the **results** of the **linear analysis**

Room Temperature after shrink fitting

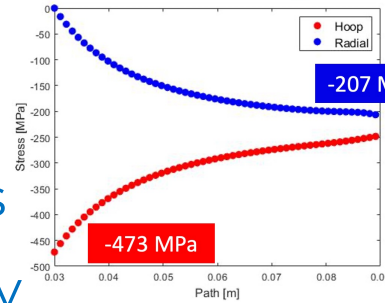

Cryogenic Temperature

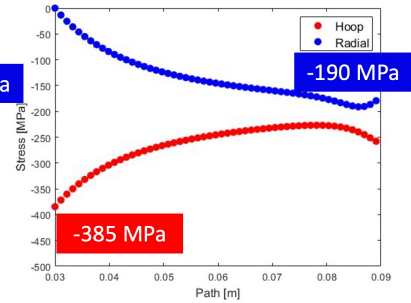

Energization at 40 T

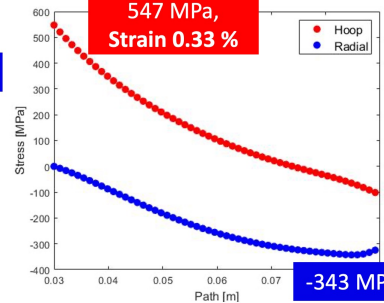

Courtesy of C. Accettura see her talk on Thursday!

- Cu yielding** needs **to be assessed** (work in progress)

*** Analysis Assumptions and **Alternative design to shrink fitting in Appendix**

Stress and strain in the 'modular coils' after shrink fitting at Room Temperature, after cooldown at 4.2 K and; at full energization (40 T)

Case	Copper in the tape, (%)	Distance between 'modular' coils (mm)	J _e (A/mm ²)	Stress (MPa) at RT		Stress (MPa) at 4.2 K		Stress (MPa) and Strain (%) at 40 T		
				Min Hoop	Min Radial	Min Hoop	Min Radial	Max Hoop Stress	Min Radial Stress	Max Hoop Strain
1	40	2	632	-473	-207	-385	-190	547	-343	0.33
2	20			-484	-211	-413	-193	529	-352	0.3
3	40	0	542	-473	-207	-385	-190	412	-320	0.25
4	20			-484	-211	-413	-193	393	-330	0.22

Protection Studies

Magnetic Energy

- The magnetic energy per meter length of an infinitely long solenoid with a uniform current is $dE_M/dz = \pi R_i P_M e(\alpha)$
 - Where $e(1) = 1$ and $e(\alpha \gg 1) \sim \alpha^2/6$
 - For $\alpha \gg 1$, $dE_M/dz \propto R_i B_0^2 \alpha^2$
 - Assuming $R_i = 3 \text{ cm}$ and $B_0 = 40 \text{ T}$
 - $\alpha = 1$ (all the current in an **infinitesimal layer**), $dE_M/dz = 1.8 \text{ MJm}^{-1}$
 - $R_o = 9 \text{ cm}$ (proposed design) $\rightarrow \alpha = 3$, $dE_M/dz = 5.4 \text{ MJm}^{-1}$
 - $R_o = 27 \text{ cm} \rightarrow \alpha = 9$, $dE_M/dz = 31 \text{ MJm}^{-1}$

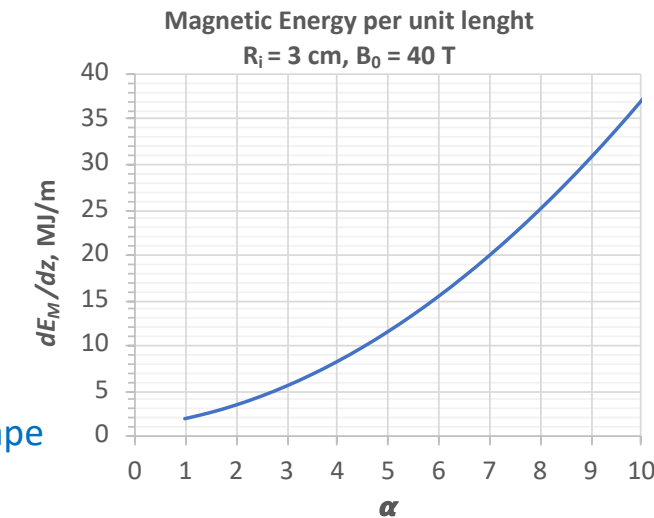
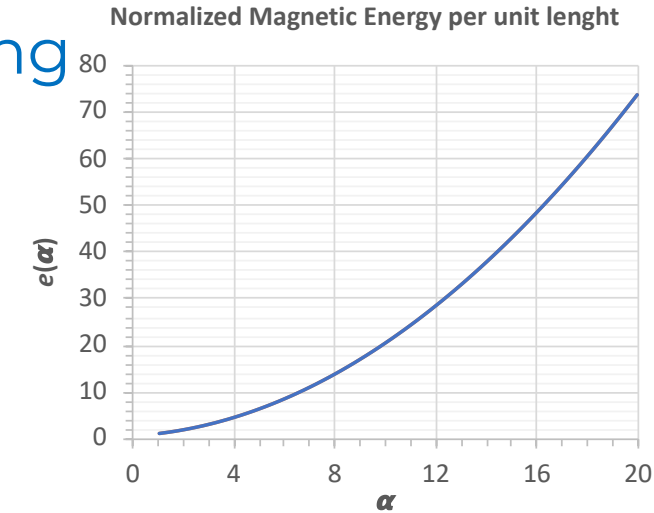

Parameters in modular pancakes

Current in the tape	760 A
Current density in the tape	632 A/mm ²
Magnetic Field in the solenoid	40 T
Pancake Inductance ¹	0.27 H
Magnetic Energy x Pancake	77 kJ
Tape length x coil	226 m
Energy density in the coil ²	300 J/cm ³

- 6 cm thick 'modular' pancakes (600 turns)
- 12 mm wide tape
- 60 mm winding inner diameter (50 mm bore aperture)
- 2 mm distance between modular pancakes

¹ Assuming a single tape conductor; in the case of a double tape conductor, the inductance would be 4 times smaller

² Tape enthalpy variation from 4.2 K to 200 K > 350 J/cm³

Protection Studies

Fast Transients

- Detailed **analysis** of **fast transients** in **Not/Metal Insulated coils** are **essential** for their **protection** (and **operation**)
- CERN started to work on it
 - **Several experts** on **quench dynamics** and SC magnets **protection**
 - **In house software** (STEAM) **validated** on numerous LTS magnet **tests/experiments**
 - **Development** of **new tools** dedicated to the transient analysis on ReBCO **not/metal insulated coils**
 - **Availability** of and **competences** on **FEM** software (**Comsol Multiphysics** and **GetDP**) running on CERN **clusters**

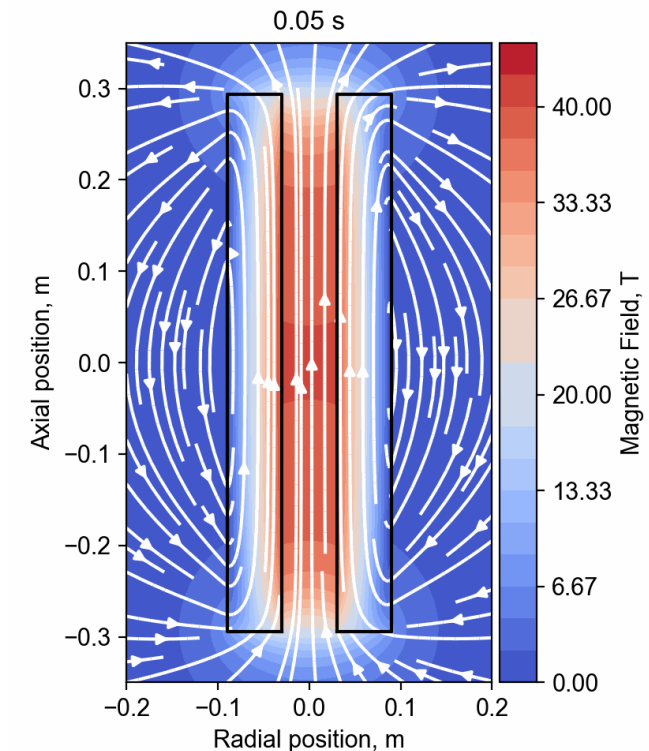

Simulation and Animation
courtesy of Tim Mulder

Relevance to Science and Society of not/metal insulated ReBCO coils 1/2

- The **potential** of a **large coils' cost/mass/volume reduction** and of operating **at 20 K**, makes this technology extremely attractable for:
 - The **Sustainability** of medium/large particle **accelerators**
 - **Compact/Modular Fusion Reactor** based on magnetic confinement
 - **High Field Science** (see previous slides)

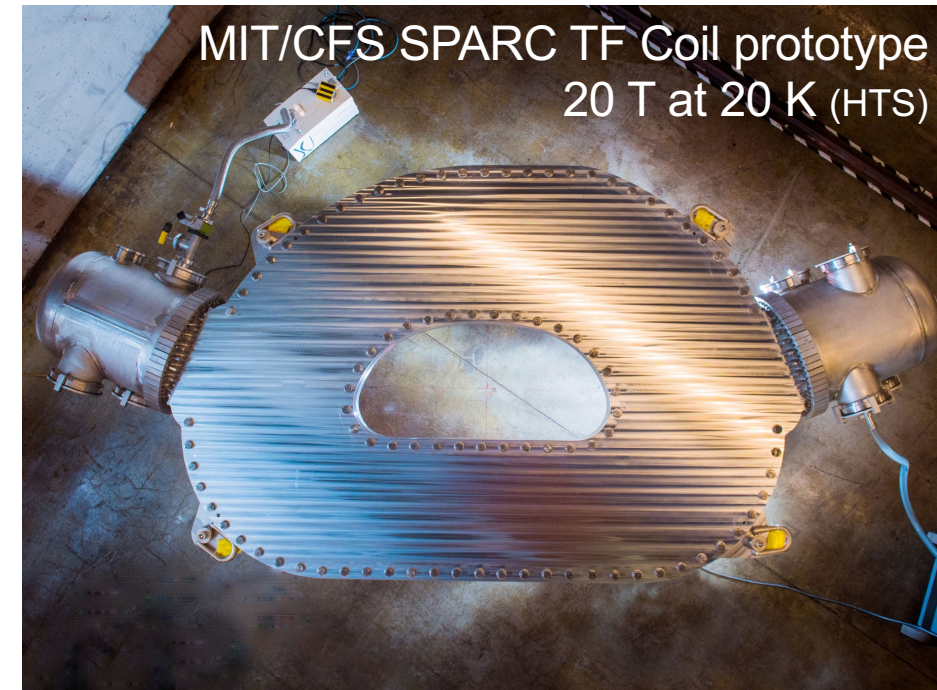

■ The development of this **technology** could also strongly **impact**

■ **Nuclear Magnetic Resonance** (see previous slides)

■ **higher fields** to improve **resolution** of the resonance spectra and the acquisition **speed**

■ **Magnetic Resonance Imaging**

■ Large bore (900 mm), high-field (11.7 T) and high-homogeneity solenoids, in persistent- or quasi-persistent mode. Nb-Ti technology is dominant but there is **strong interest for HTS**, especially for **cryo-free operation**.

■ **Wind turbine generators**

■ Compact generator essential ingredient for large turbines, the trend is now for $\gg 1$ MW turbines



UHF MRI magnet (11.7 T, 900 mm bore, full body) developed by CEA/Alstom

Courtesy of L. Quettier



(left) The 3.6 MW EcoSwing HTS generator (blue, 4 m diameter) next to its conventional counterpart with the same power rating (red, 5.4 m diameter), prior to (right) its lift onto the turbine

<https://www.utwente.nl/en/tnw/ems/research/sust/EcoSwing/>



Main Conclusions



- The conductor **critical current** seems **not** to be a **limiting** factor for a all ReBCO 40-50 T solenoid with a 50 mm bore
- The proposed **conceptual design** shows the **potential** for developing a **compact 40 T** final cooling **solenoid**
- **Two** main **criticalities** have been **identified**:
 - The **electro-mechanical** design → **stresses** on the **conductor** are very large
 - The **electrodynamics** and **protection** of the magnet → **complex transients** to control
- CERN, INFN, CEA, CNRS, PSI, UniGE, SOTON, UniTwente started to tackle these criticalities via modeling and experimental activities*
- **Enthusiastic young researcher** strongly push the fast progresses of the project
- **If** proven **successful**, this technology will have a **huge relevance to Science and Society**

***More on experimental activities in appendix**

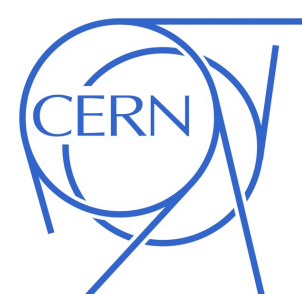

IJCLab Orsay, France 19-22 June 2023

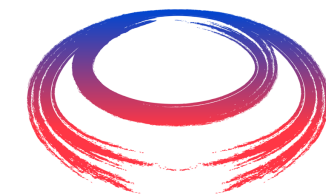

International
UON Collider
Collaboration

**Thank You For the
Attention**



APPENDIX

Mechanical Analysis I

assumptions and analysis

- Main assumptions: fully elastic, Isotropic approximated Young Modulus (150 GPa); no thermal contraction; 200 MPa coil precompression; 100 μm thick ReBCO tape with 50 μm of Hastelloy and 40 μm Cu

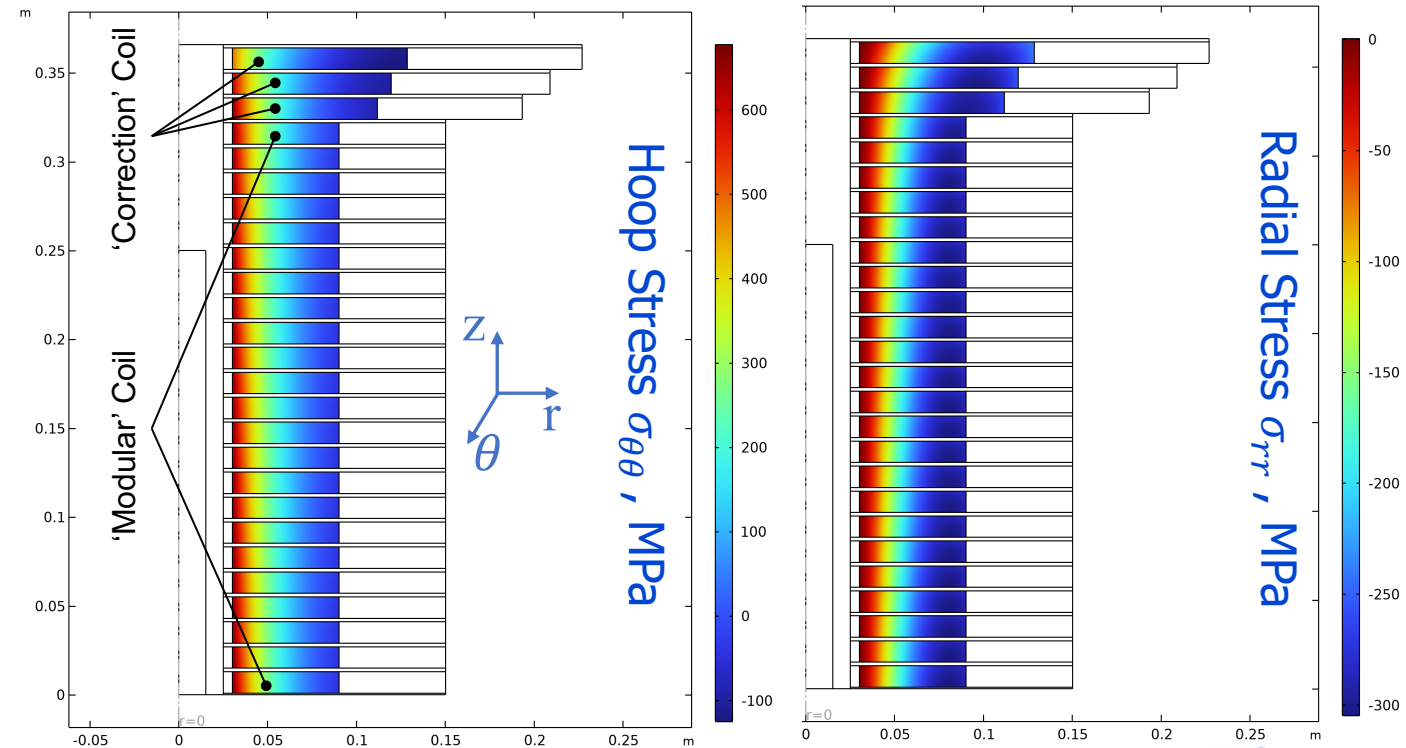

Mechanical Analysis II

assumptions and type of simulations

- Main electromagnetic assumptions: uniform current density, infinite solenoid field distribution
 - representative of a 'modular' coil sufficiently far from the solenoid extremities in stationary conditions
- Main mechanical assumptions: fully elastic, orthotropic mechanical material properties
 - homogenized with different rule of mixtures depending on the considered property and direction
- Performed analysis
 - Mechanical ANSYS simulation to calculate the stress in a modular coil during
 - The 200 MPa precompression applied on the coil at room temperature via shrink fitting by two preheated concentric rings
 - The cool down of the assemble from RT to 4.2 K
 - The energization at 4.2 K of the pre-compressed coil

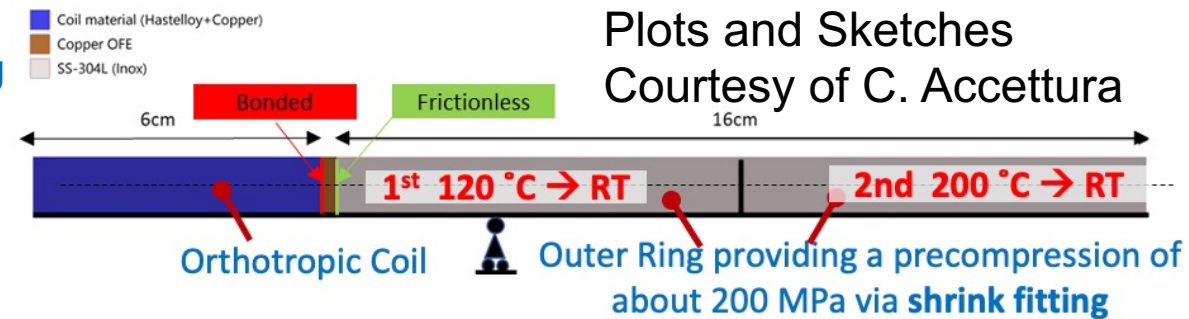
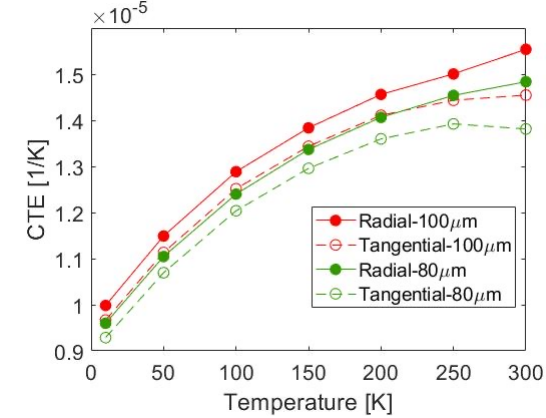
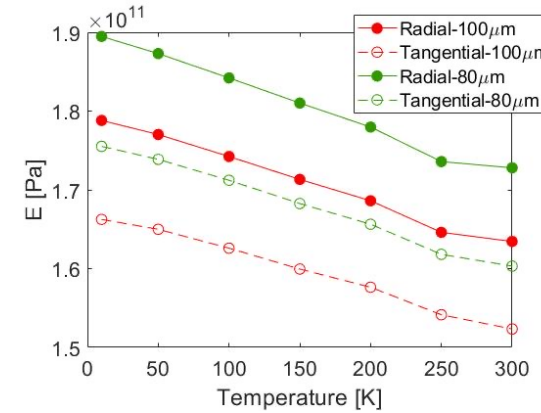

¹ S. Yoon et al. Supercond. Sci. Technol. 29 (2016) 04LT04

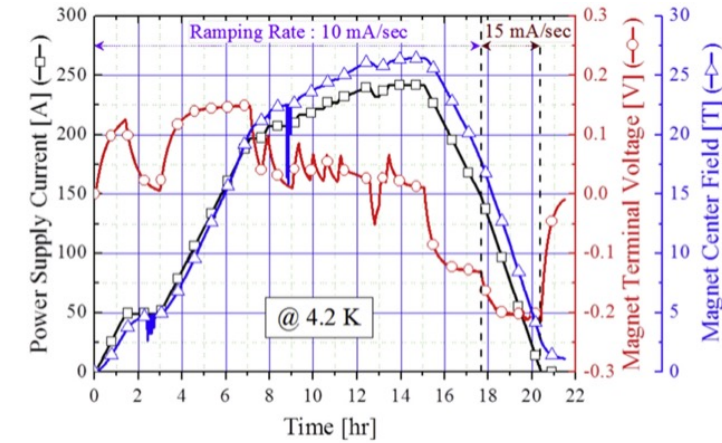

- The required **energization time, 6 hrs**, seems **achievable** for **Not/Metal Insulated coils**
 - the 26.4 T Sunam NI coil was energized in about **14 hrs¹**, despite the **very low** surface **contact resistance, 9.6 $\mu\Omega$ cm²**
 - In **previous** smaller small-scale **REBCO NI test coils**, the same group found a surface **contact resistance** about **7 times larger¹**
- The surface **contact resistance** can be **increased** by **reducing** the **Cu** content in the conductor, **especially** on the tape **edges**, and/or interposing a **resistive metal tape** in between the turns, or ...
- **Studies** for **defining** the proper surface **contact resistance** and **how** to **achieve** it consistently, also **considering** the magnet **protection** and the required field persistency, are **on going**
 - To meet operation requirements, **other solutions**, as **correction coils** or a **power supply** with **active feed-back**, are **also considered**



Some info on the experimental work



- The design work is complemented by a focused testing activity on short samples and coils, devoted to measuring directly performance and technology limits
- Electro-mechanical characterization relevant to UHF conditions, at University of Geneva (new experiment on single tape) and university of Twente
- Small pancakes manufactured and tested by CERN EP-ADO, possibly INFN-LASA and other beneficiaries. This activity profits from ongoing developments, and extends it

Courtesy of L. Bottura

Some info on the experimental work

Precompression studies

- Necessary to characterize mechanical properties of representative coil samples to validate this concept → a compressive jig with controlled compressive force is proposed to test pancake coil (customized design based on Shrink Disc concept) at CERN Mechanical Measurement Lab

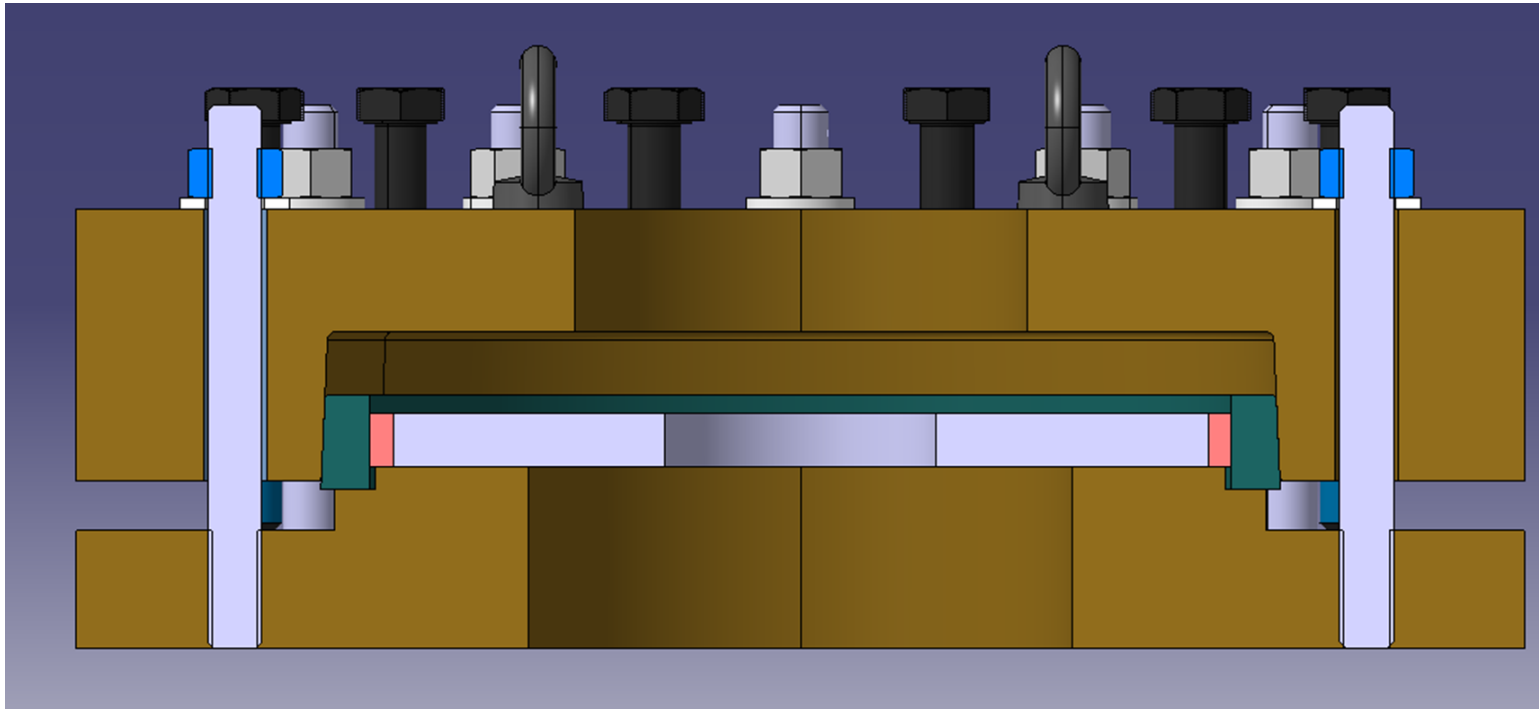

Courtesy of A. Bertarelli, F. Sanda A. Kolehmainen

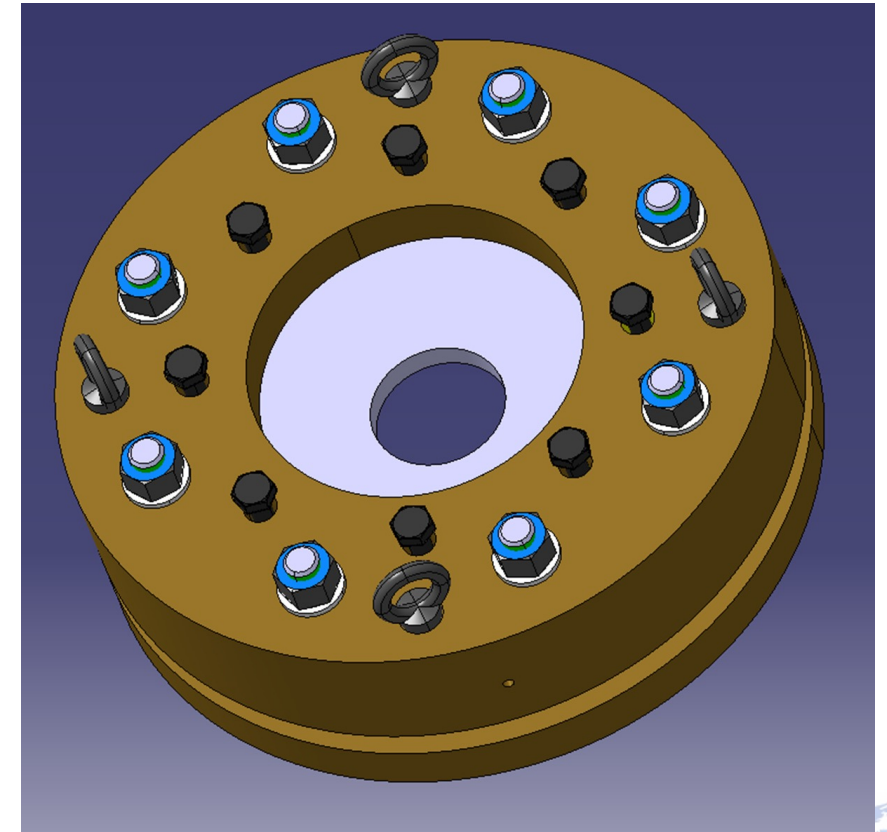

Some info on the experimental work

Winding & Plating Studies

- A small winding machine, also allowing tin coating has been built at CERN to start winding and plating studies

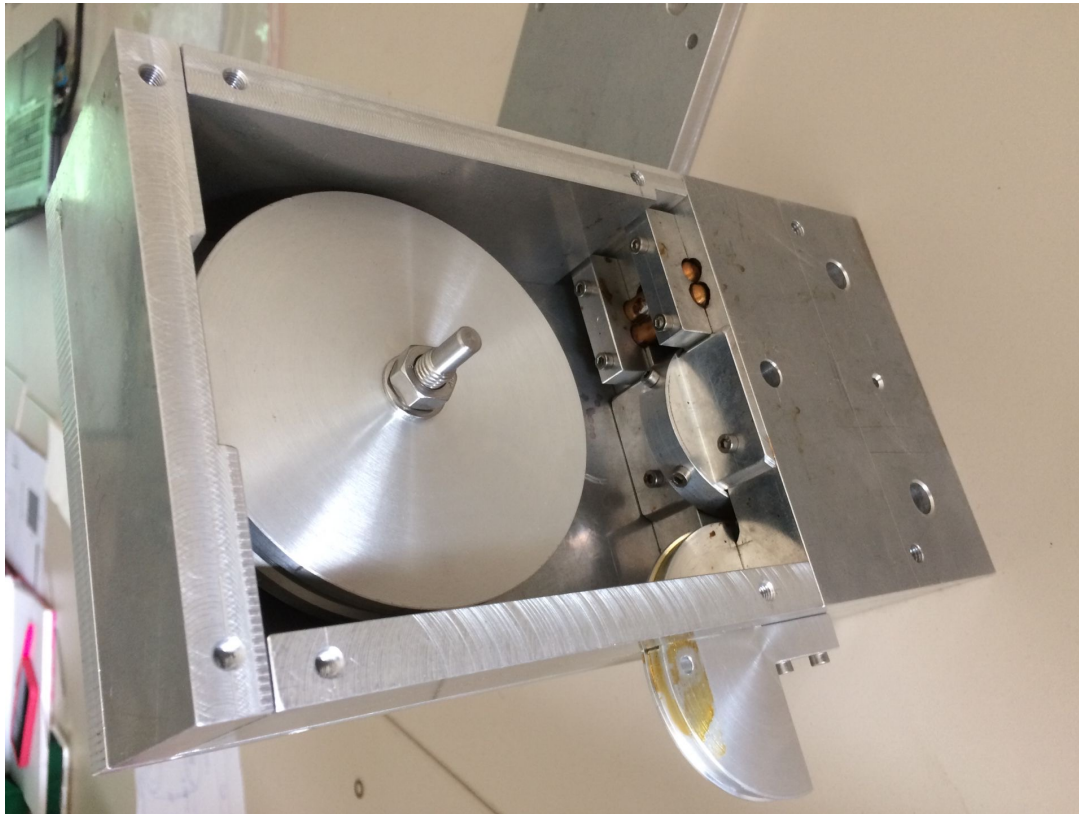

A Pancake is wound on Hastelloy solder coated 1-2 mm ring at $190 < T < 200$ degree at certain tension

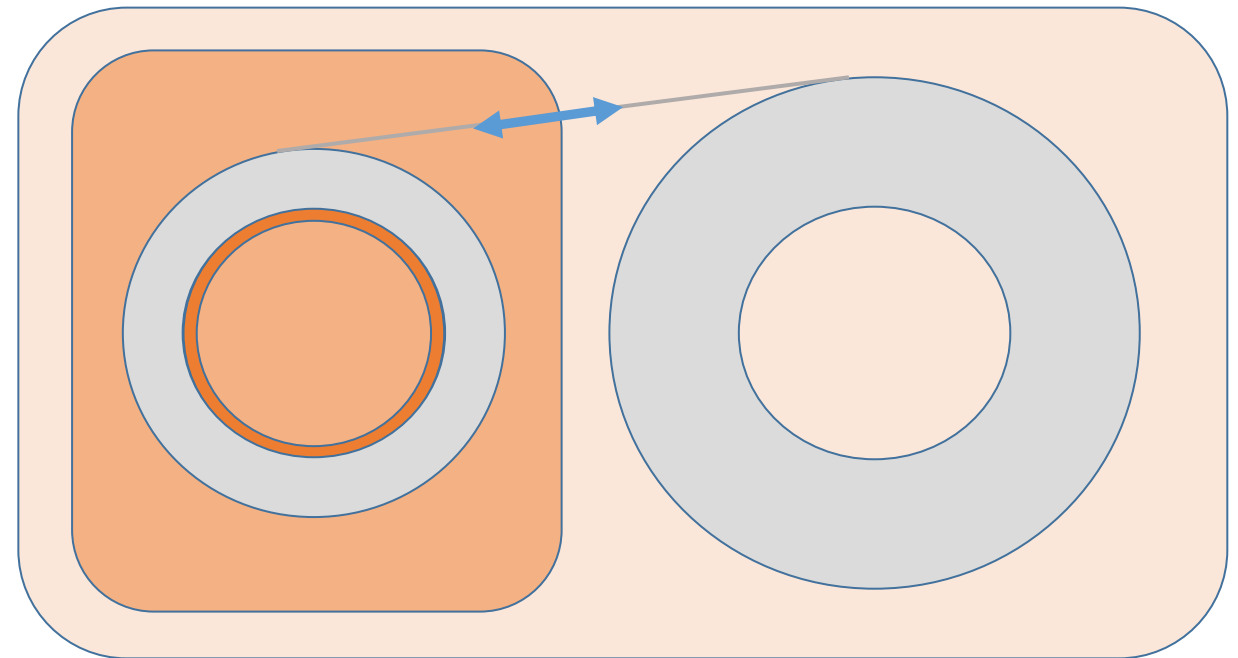

Courtesy of A. Dudarev



Some info on the experimental work

Why a small-size single pancake or a stack of pancakes ?



Courtesy of L. Bottura

- It is the natural intermediate step between the tape critical current, and other tests, and the final solenoid configuration
- It is easy to wind and test
- It reproduces relevant conditions of field, force and energy density (can be tested in a background field)
- It is small and does not waste material
- Parametrical studies can be performed to test fabrication parameters and manufacturing technique (winding tension, insulation method...)
- With properly chosen geometry it can be used to test some of the technology of a final solenoid (joints, resistance control, reinforcements)

Some info on the experimental work

Reference pancake configurations

■ Geometrical Parameters

- 60 mm inner diameter
- 20 mm and 60 mm thickness
- 4 mm and 12 mm tape width
- Single and double pancakes winding
- One- and two-in-hand winding
- Pancakes can be stacked in mini-coils

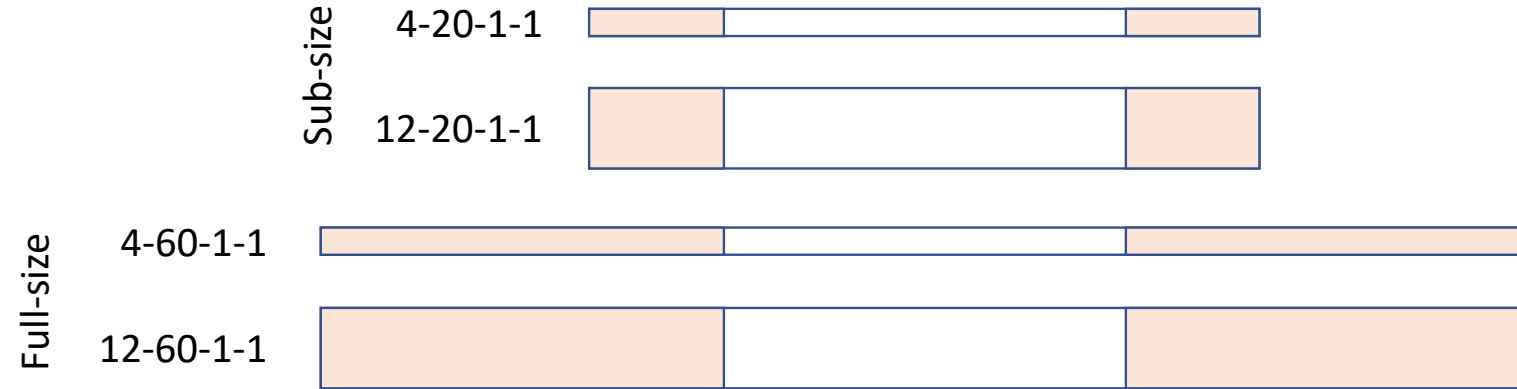

Courtesy of L. Bottura

- Identical/similar configurations used at CERN, INFN, PSI



Some info on the experimental work

Test of pancakes as inserts



- Testing at LNCMI of a selected number of coils/stacks is foreseen as part of MuCol Task 7.2
- 20 T, 170 mm warm bore, 120 mm cold bore
- Could host the 20 mm thick stacks, total field reach approximately 40 T
- Two sessions per year are planned, each testing session is one week long
- Testing time in 2024 should be declared at the next call (November 2023)
- LNCMI is eager to collaborate, to advance their R&D, and prepare the upcoming INFRA-TECH-24-01 proposal (due Spring 2024)

Courtesy of L. Bottura