

Facts and figures

- 26 PLCs:
 - 19 PLCs are upgraded to ABB AC500
 - 7 PLCs are being upgraded
- Staff involved in PLC upgrades:
 - 1 person → allocated 100%
 - 3 people → allocated +/- 20-30%
- Coding language:
 - Old: Function Block Diagrams (FBD) + Sequential Function Charts (SFC) + Structured Text (ST)
 - New: Structured Text (ST)



System overview

Old situation:

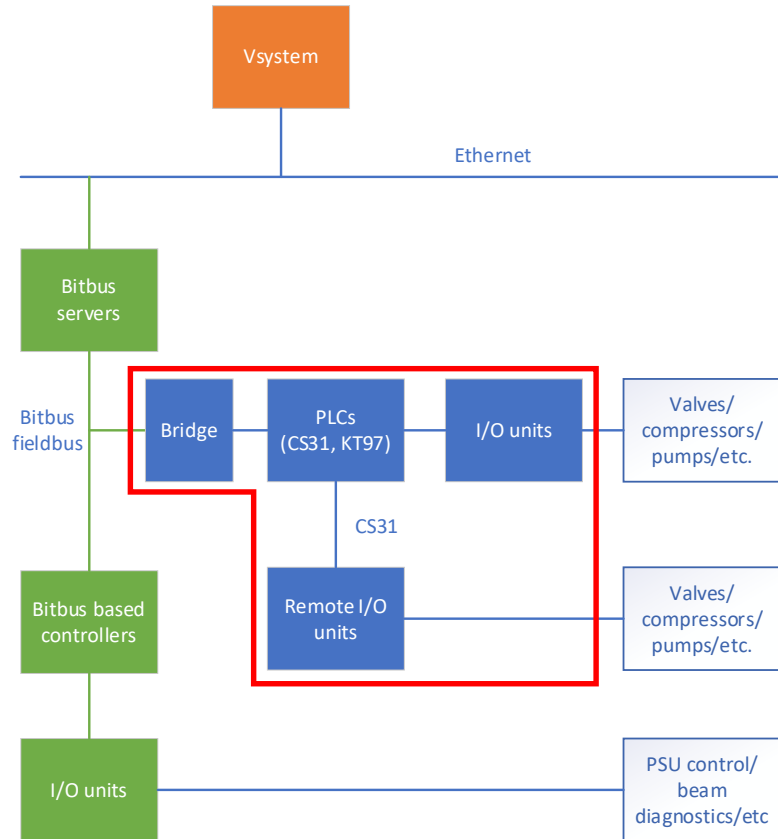

New situation:

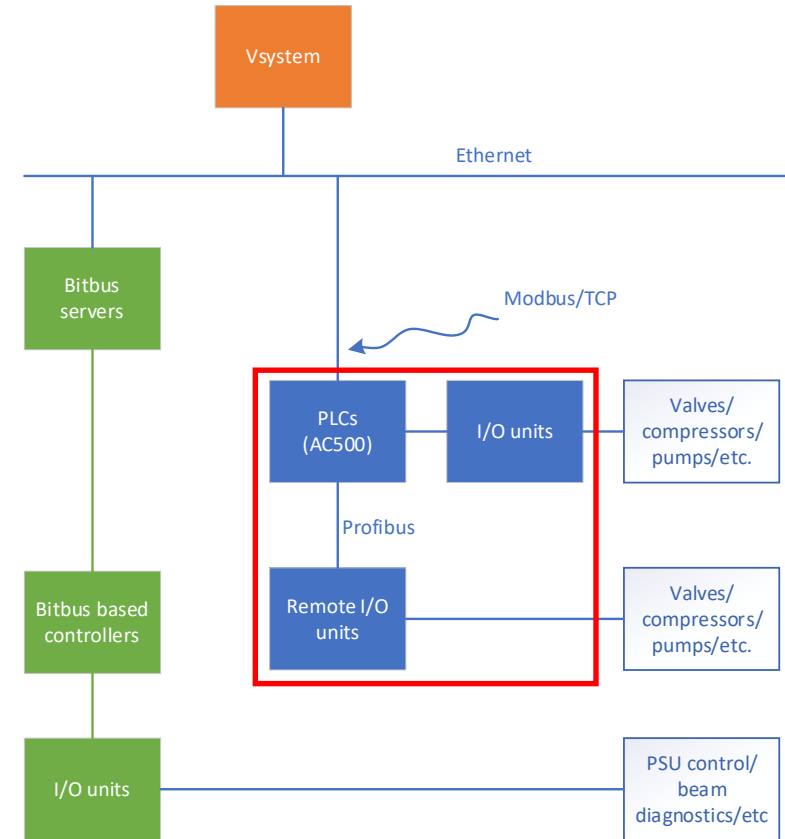

Control system software upgrade?

New situation:

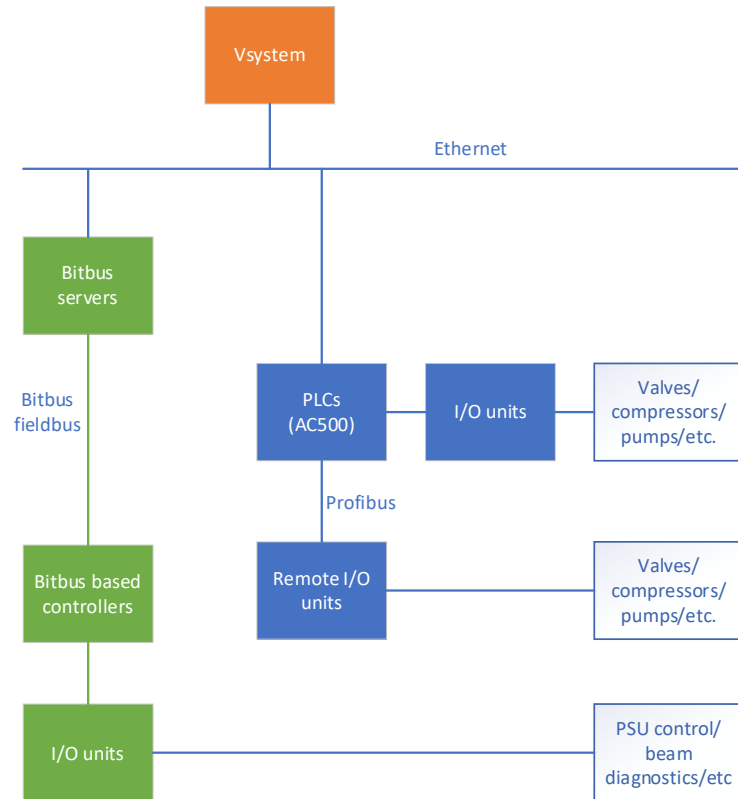

Future situation?

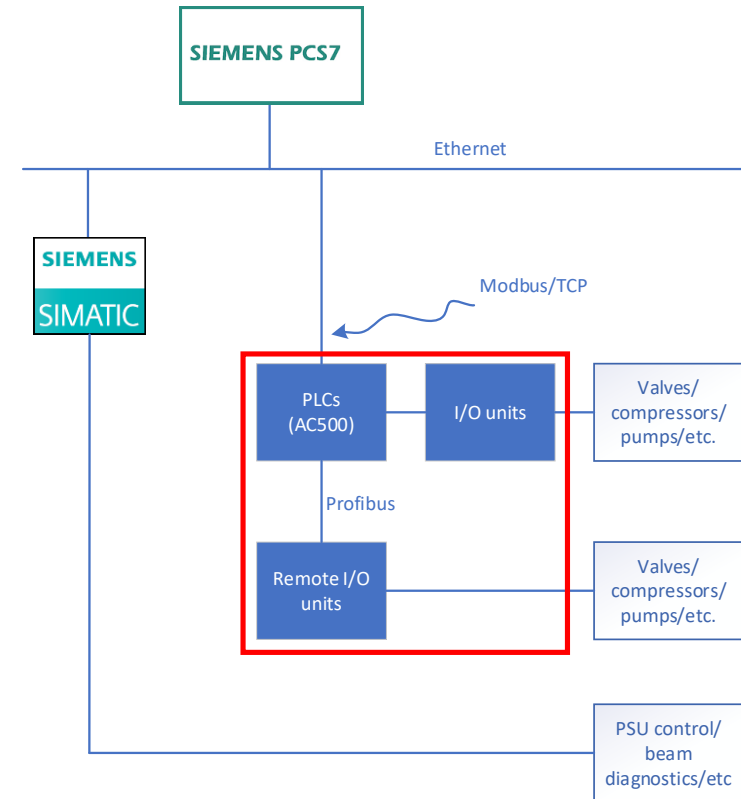

Challenges

1. Coding standard
2. Uniformity in test and release procedure
3. Reluctance in upgrading the development software version for new versions of existing PLC code
4. Re-use of code (copy vs. custom libraries)

