

PAUL SCHERRER INSTITUT

PSI



WIR SCHAFFEN WISSEN – HEUTE FÜR MORGEN

Cornelis B. Doorenbos on behalf of the nEDM collaboration Paul Scherrer Institute

Commissioning of the ultracold neutron guide system for the n2EDM experiment at PSI

Swiss Physical Society annual meeting 2023

Basel

The n2EDM experiment

- Search for the neutron electric dipole moment (nEDM) using stored ultracold neutrons (UCN).

- Statistical sensitivity:
$$\sigma(d_n) = \frac{\hbar}{2\alpha|E|T \sqrt{N}}$$

- We need a good UCN transport system!

UCN are storable neutrons

- Ultracold
 - $E_{\text{kin}} < 300 \text{ neV}$ $T \sim 2 \text{ mK}$ $v \sim 5 \text{ m/s}$
- Material interactions: Fermi potential (V_f) approximates strong force
 - If $E_{\text{kin}} < V_f$
 - Reflection under all angles
 - Storable
- Magnetic traps ($dV/dB = \pm 60 \text{ neV/T}$)
- Gravity traps ($dV/dh = 102 \text{ neV/m}$)

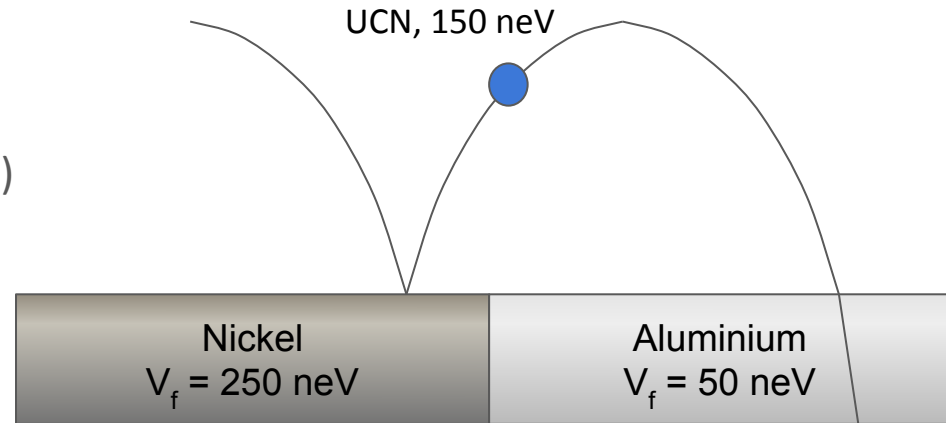

UCN Source at PSI

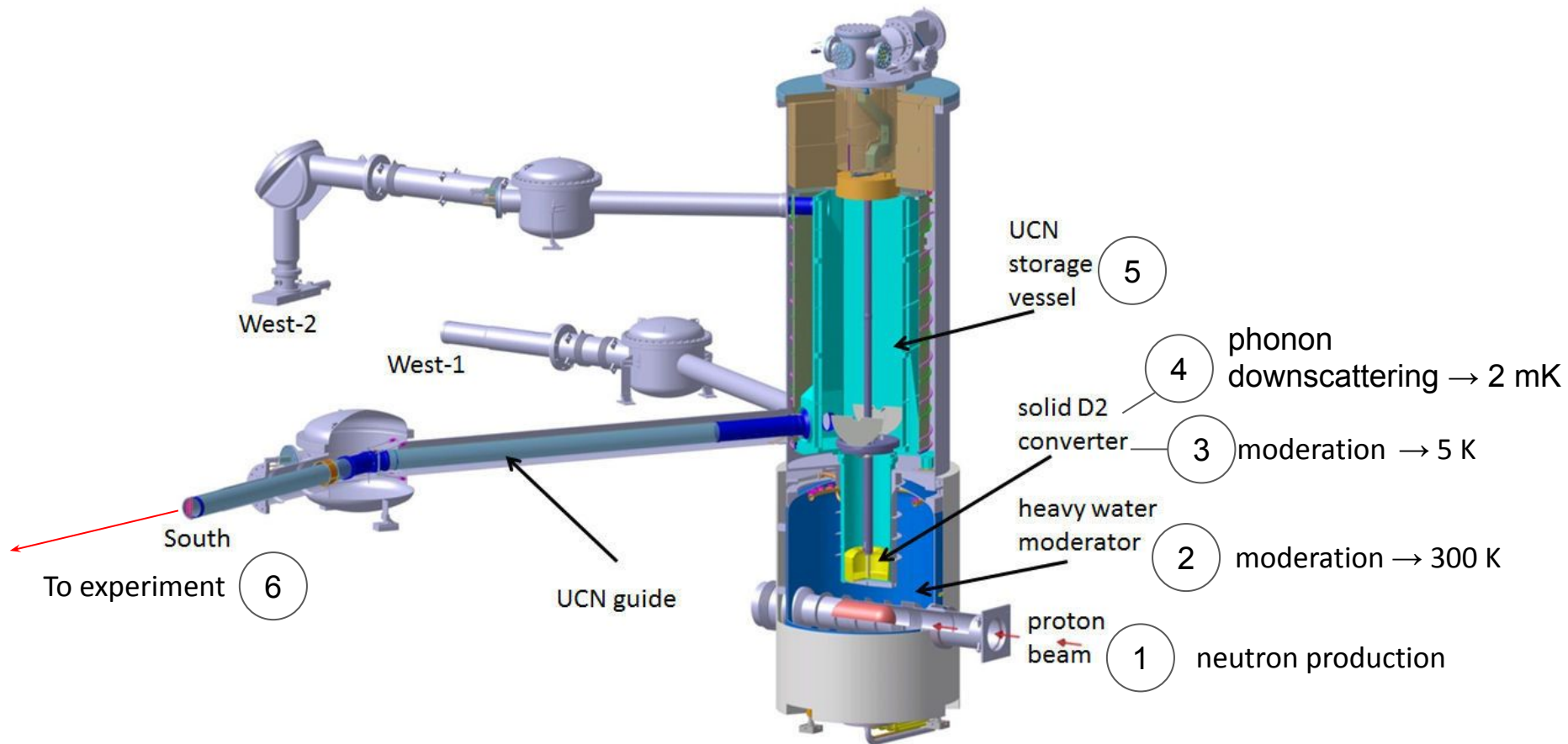

Requirements for UCN guides

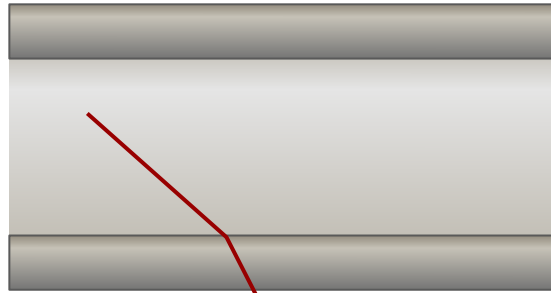

Fermi potential

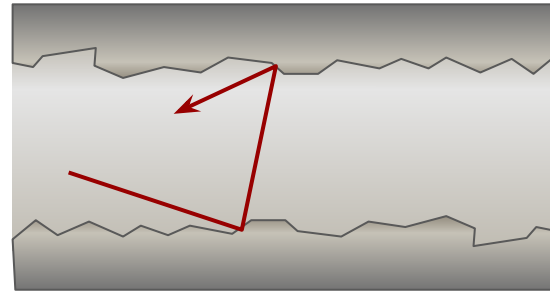

Smoothness

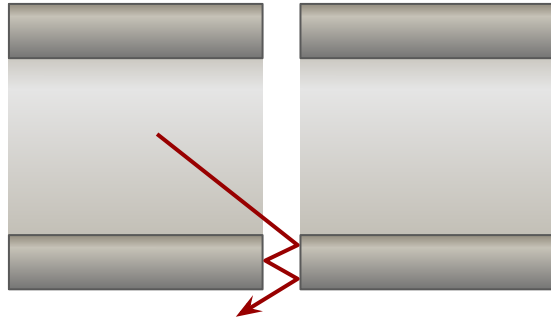

Gaps between guides

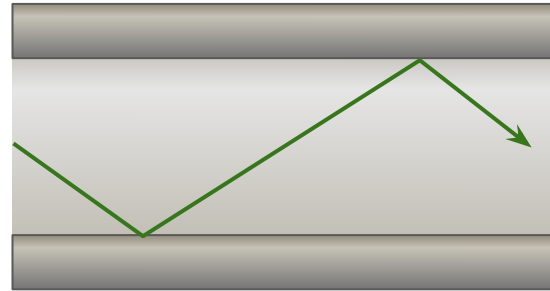

Required transmission:
90 % for 1m guide

UCN guides

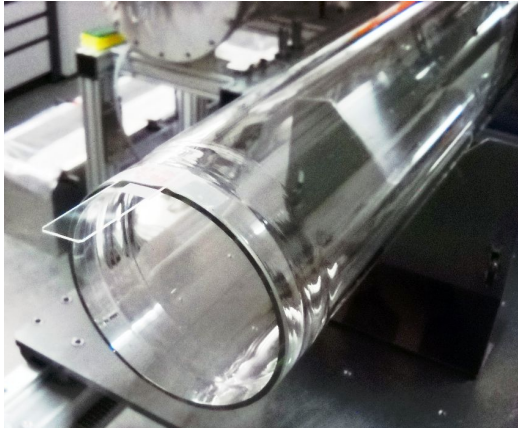

Glass guides

- smooth
- Inner diameter: 13 cm
- Length: varies, up to 125 cm

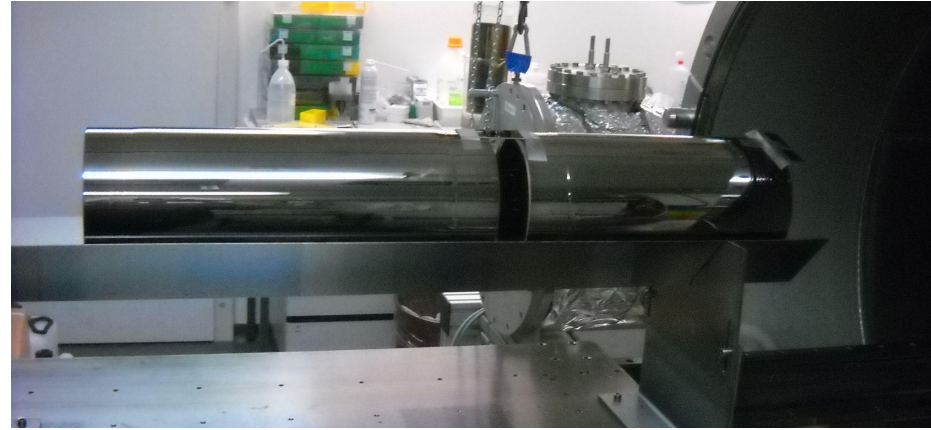

NiMo coating (85:15 mass ratio),

- $V_f = 220$ neV
- Ni: high fermi potential, but ferromagnetic
- Mo: reduces Curie temperature well below room temperature

Coating

In house, DC magnetron sputter coating facility

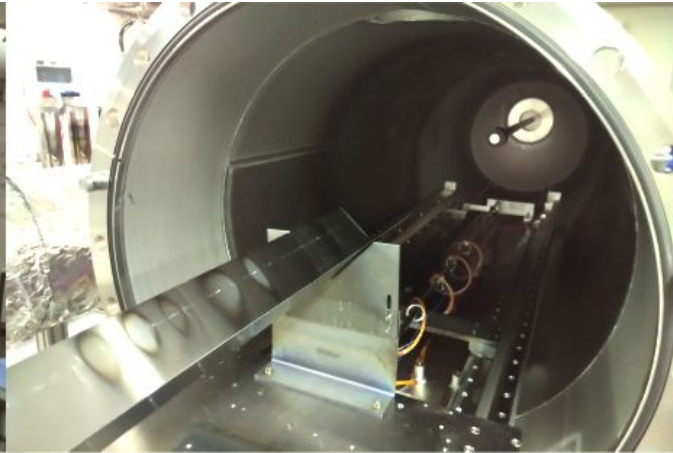
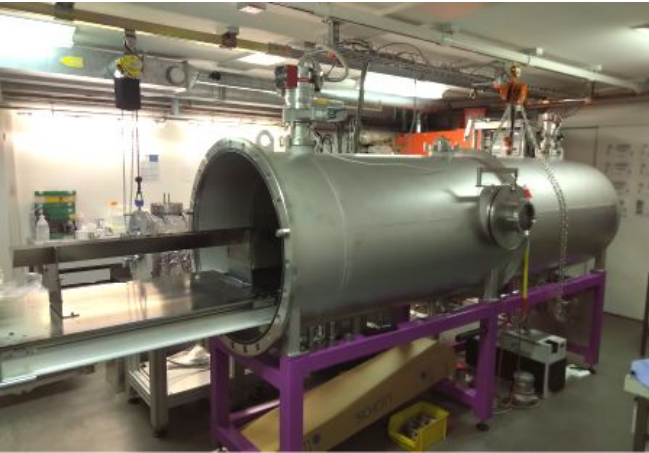

The n2EDM experiment

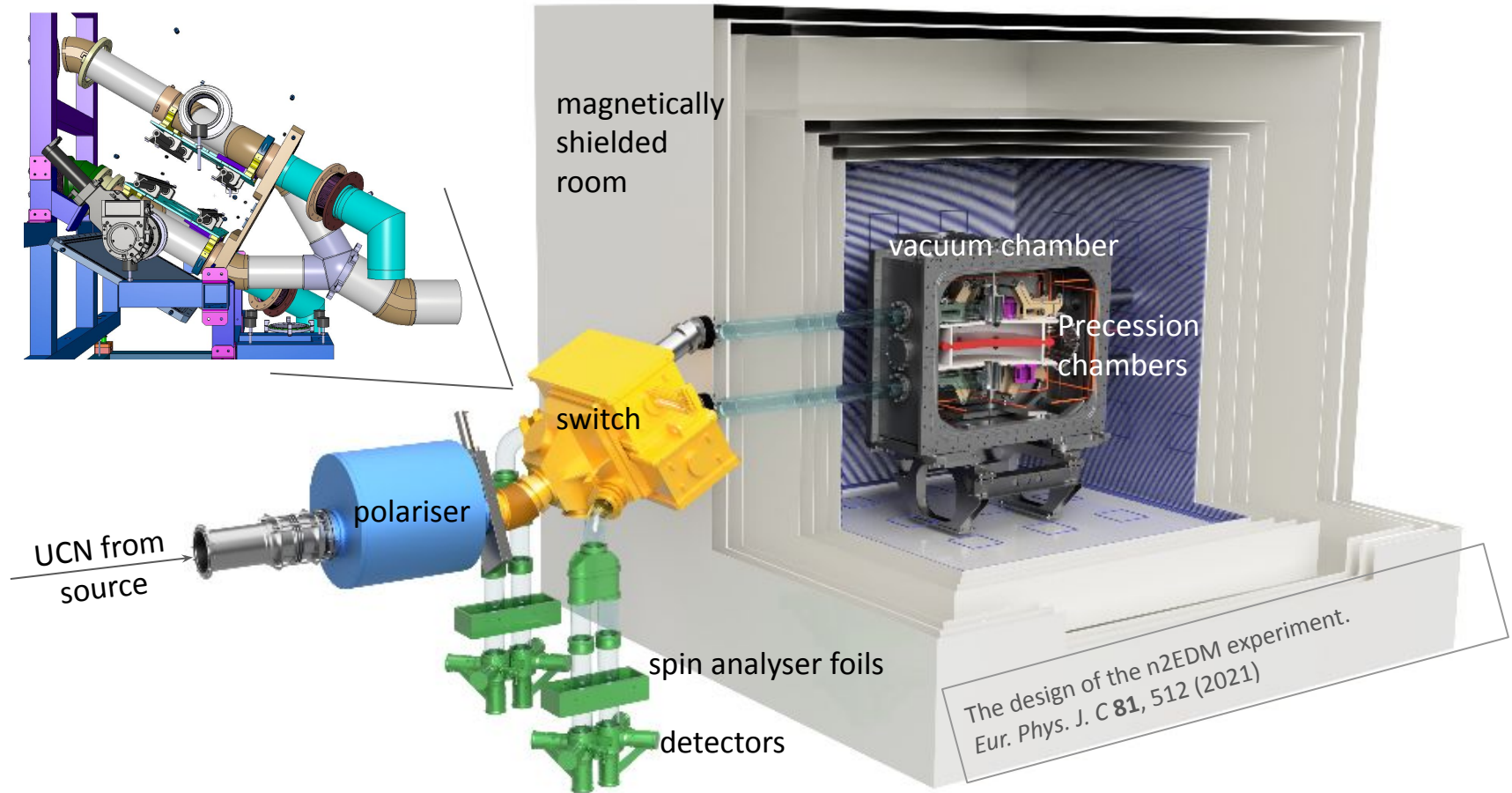

The guide system

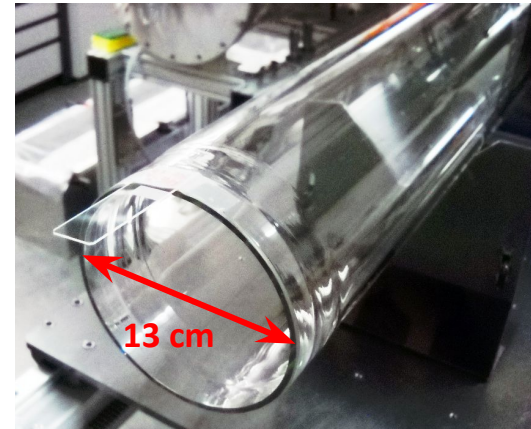
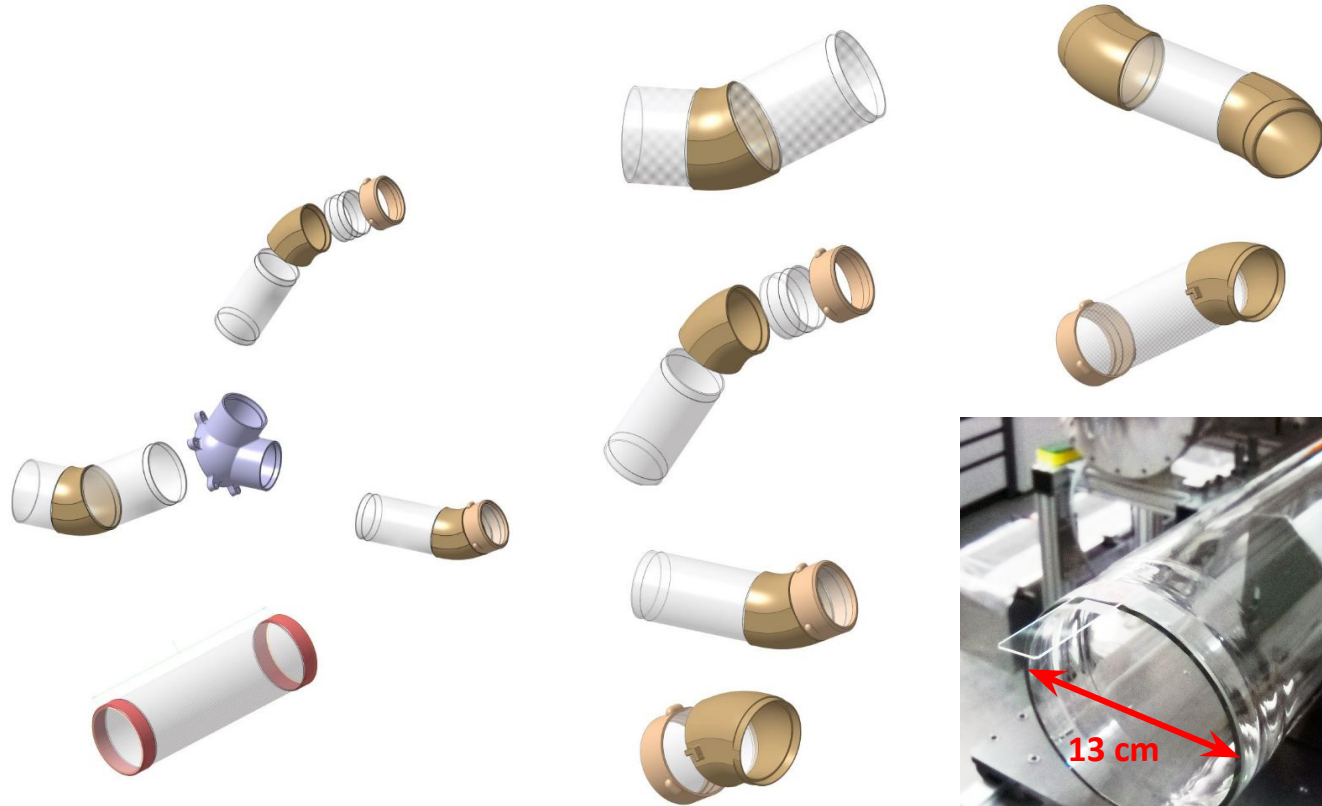

UCN transmission measurements

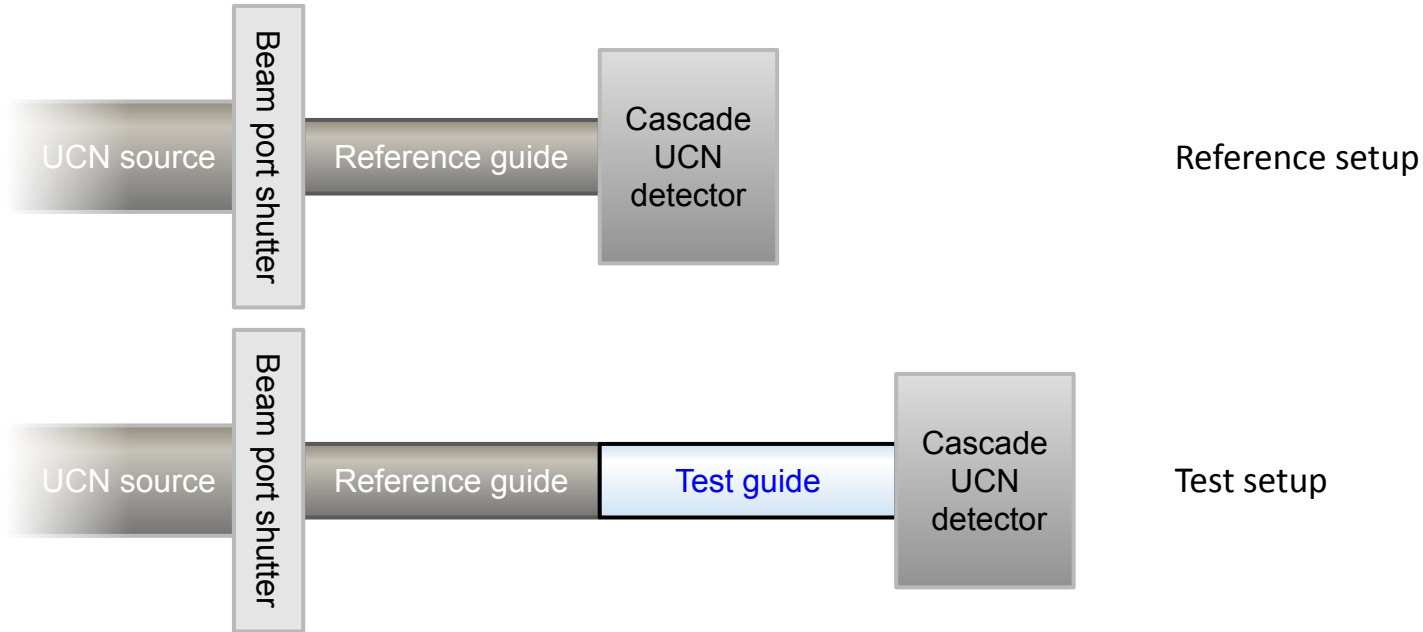

$$\text{Transmission} = \frac{\text{normalised UCN counts in test setup}}{\text{normalised UCN counts in reference setup}}$$

UCN transmission measurements

- Region of interest: 12-200s
- not all neutrons before 12s are storable

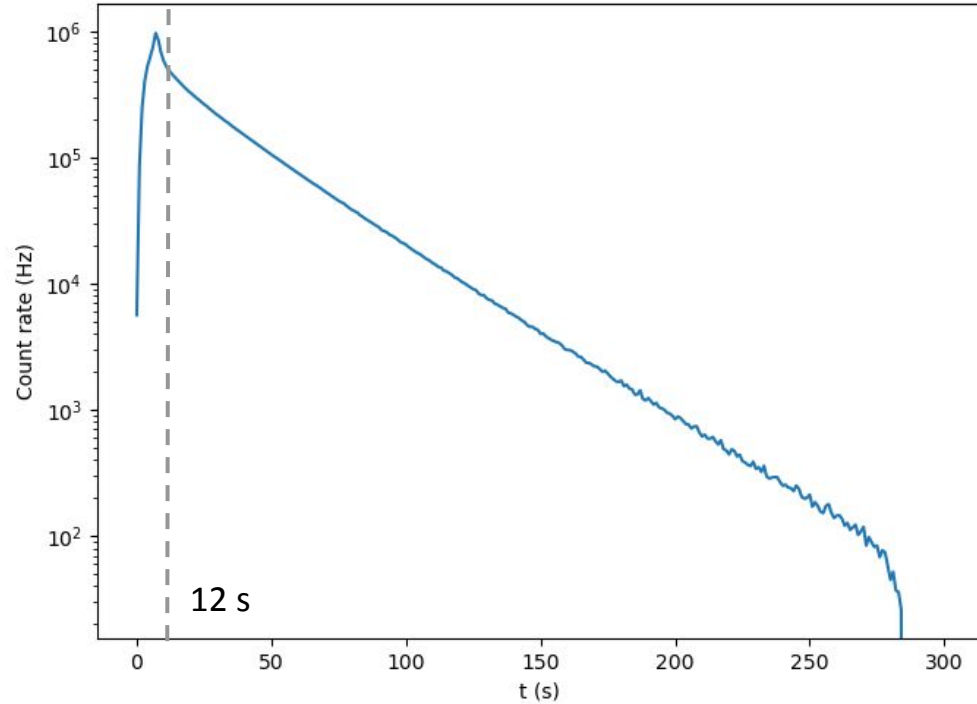

UCN transmission measurements, results

- UCN guides not equal in transmission
- Transmission is UCN energy spectrum dependent (higher transmission for lower energies)

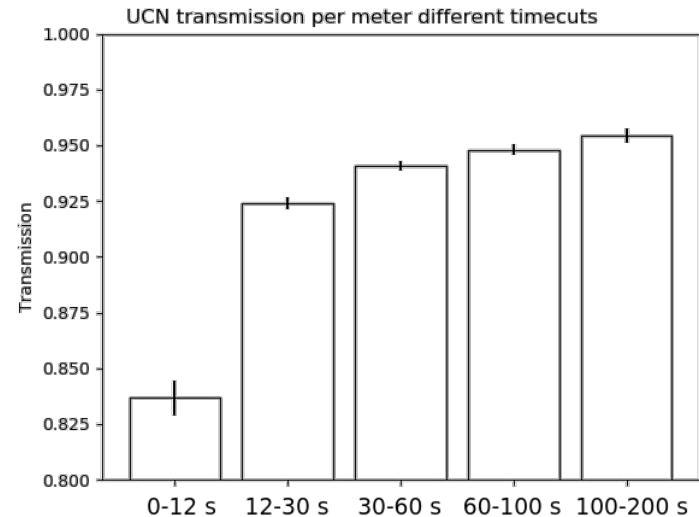
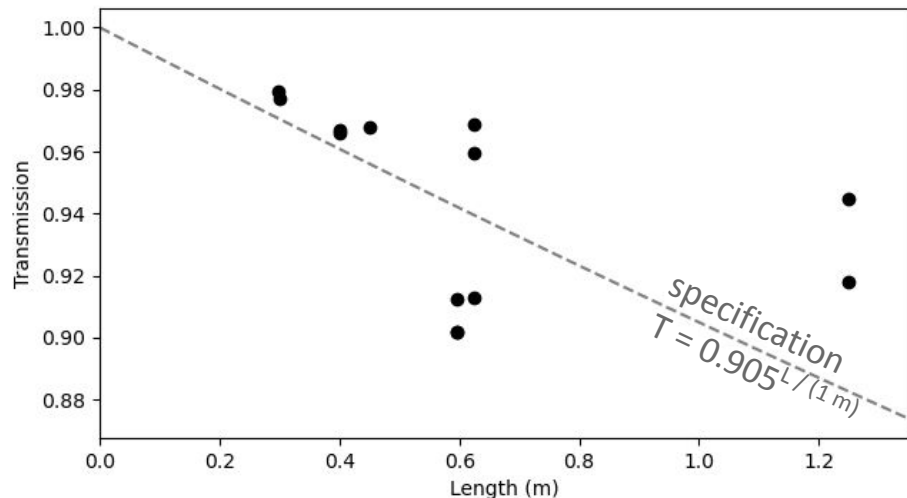

Measurement of V_F

Reflectometry

Confirmed that for our NiMo coating

$$V_F = 220$$

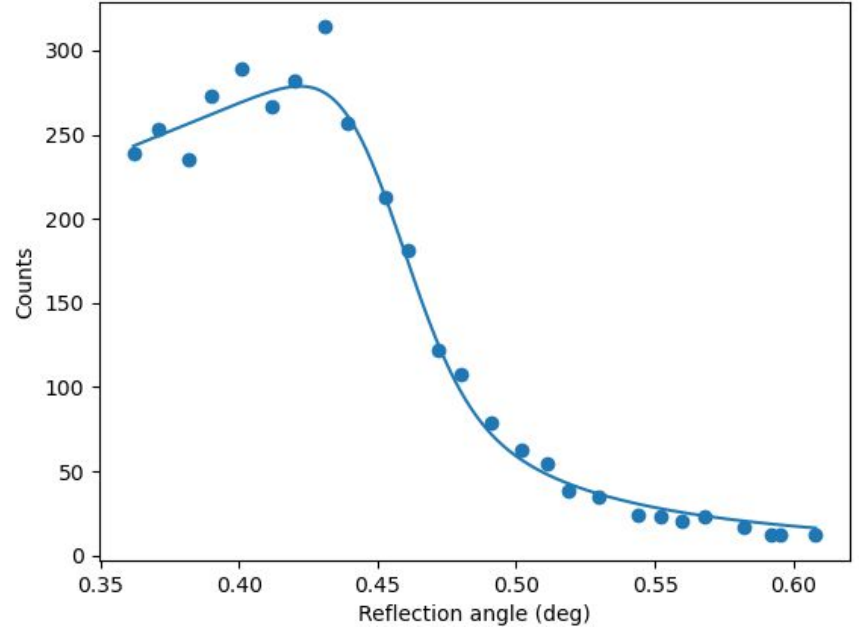
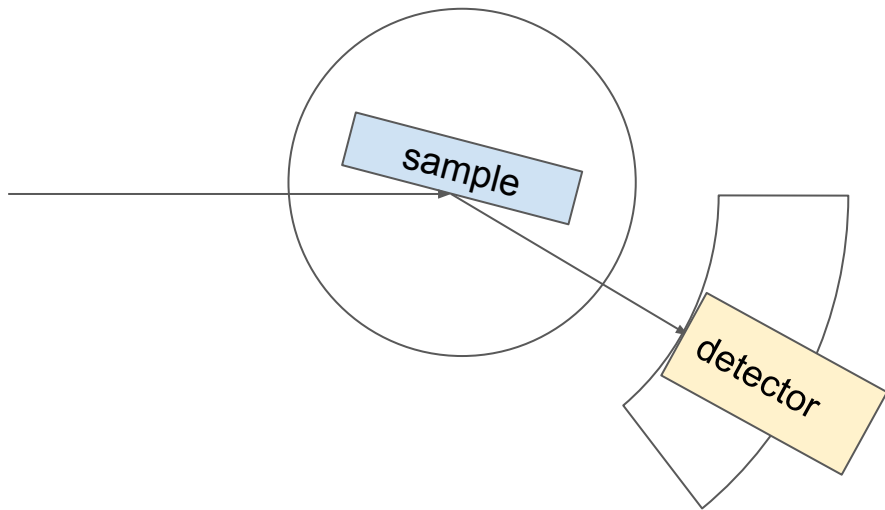

UCN transport simulations

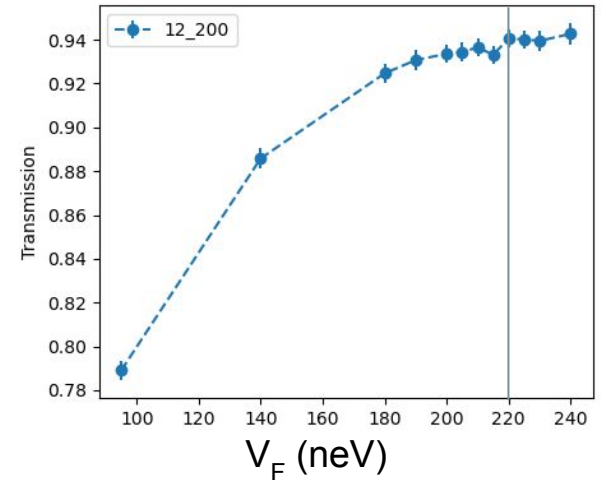
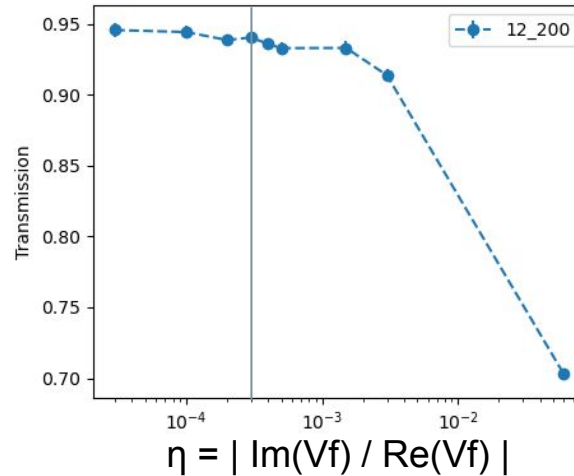
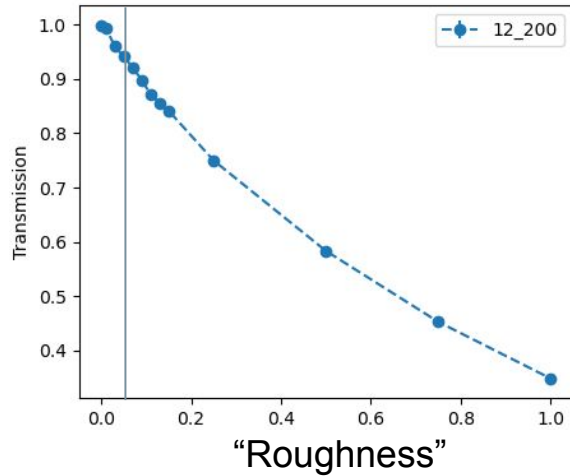

- Simulation of the transmission measurements, from source to detector
- Diffuse scattering fraction ("roughness") explain differences (Lambert model)
- Not caused by coating, intrinsic to guides
- Not sensitive to the other parameters

The MCUCN simulation code for ultracold neutron physics
Nucl. Inst. and Meth. A, Vol. 881, p. 16-26.
<https://doi.org/10.1016/j.nima.2017.10.065>

Checking for magnetic dipoles

- Guides closest to precession chamber
- Limit for magnetic contamination:
 - 16 nA m²
 - 25 pT at 5 cm distance
 - 2 million times lower than geomagnetic field
- The guides fulfil the specifications

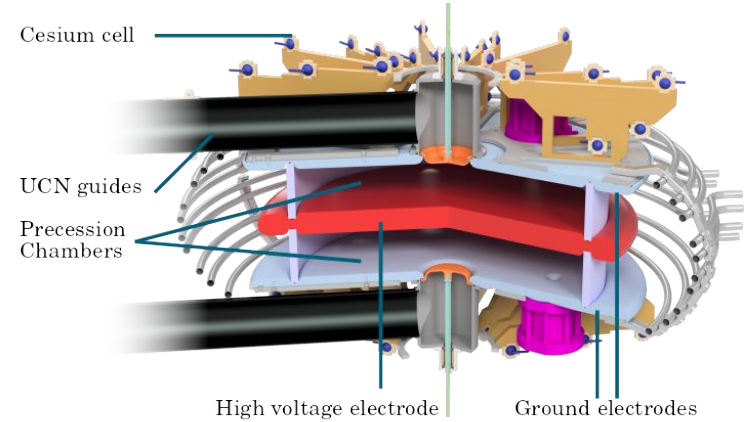

Summary

- Our goal: to search for nEDM with 10^{-27} e cm sensitivity
- Our requirements
 - Transmission per meter > 90 %
 - Magnetic contamination: < 25 pT
- Most guides we produce satisfy these requirements



Checking for magnetic dipoles

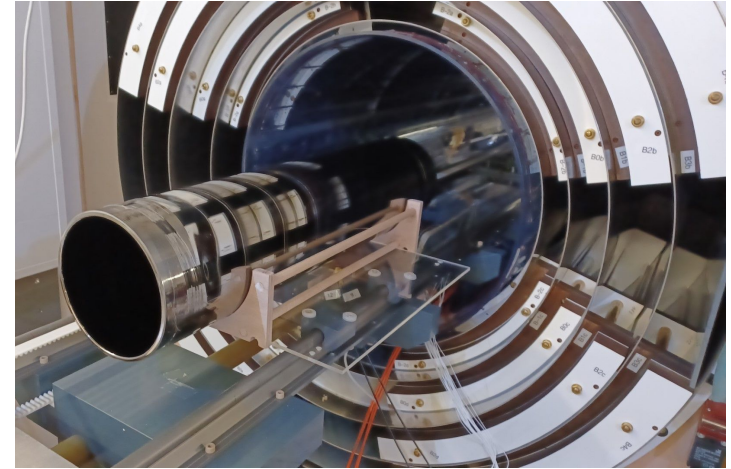
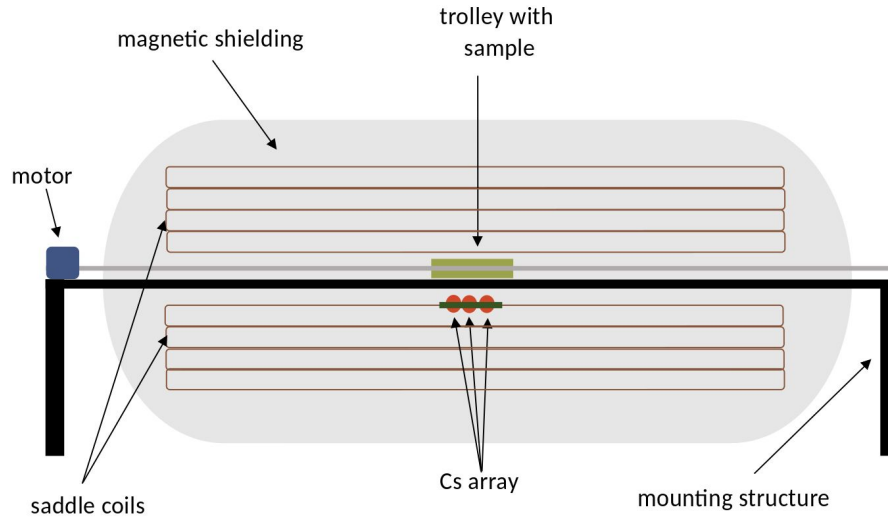

- Vertical B_0 field: 2.6 μT
- Sample driven past Caesium magnetometers
- Quantity of interest: ΔB between Cs magnetometers
- Sensitive to dipoles of 1 nA m^2 (1 pT level)

Example dipole signal

- PEEK (plastic)
- Signal: C2 - C1

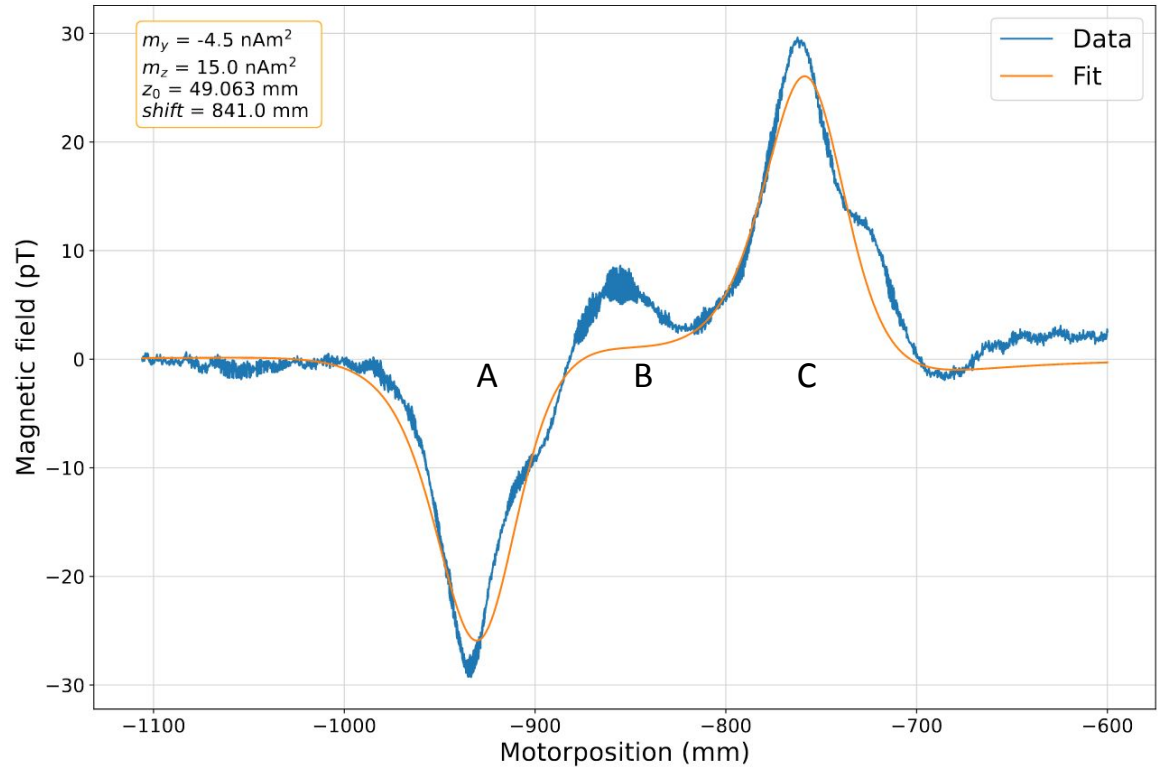
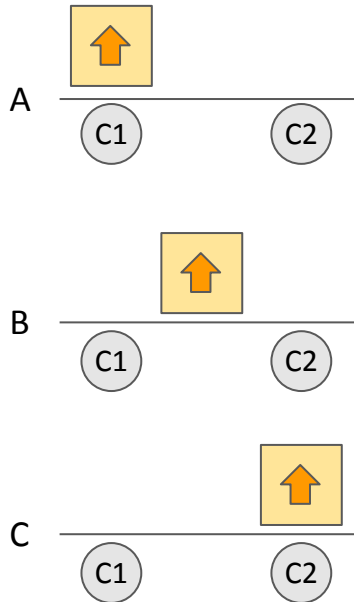

UCN guide dipole scan

Max allowed
dipole strength:
10 nAm²
16 pT

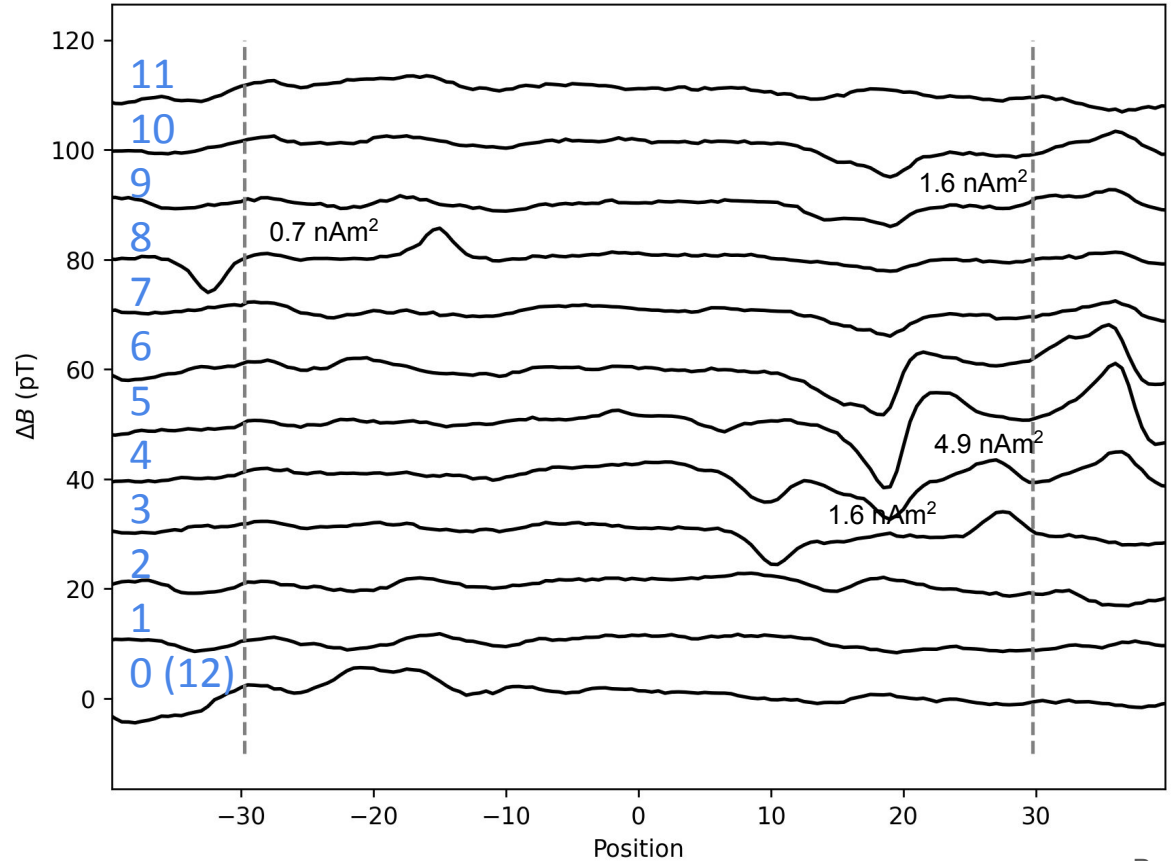
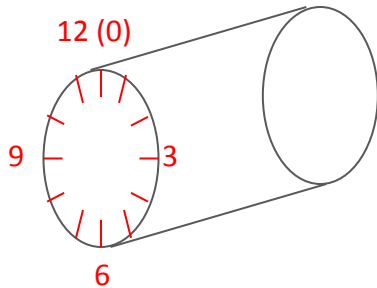

UCN guide dipole scan, degaussed

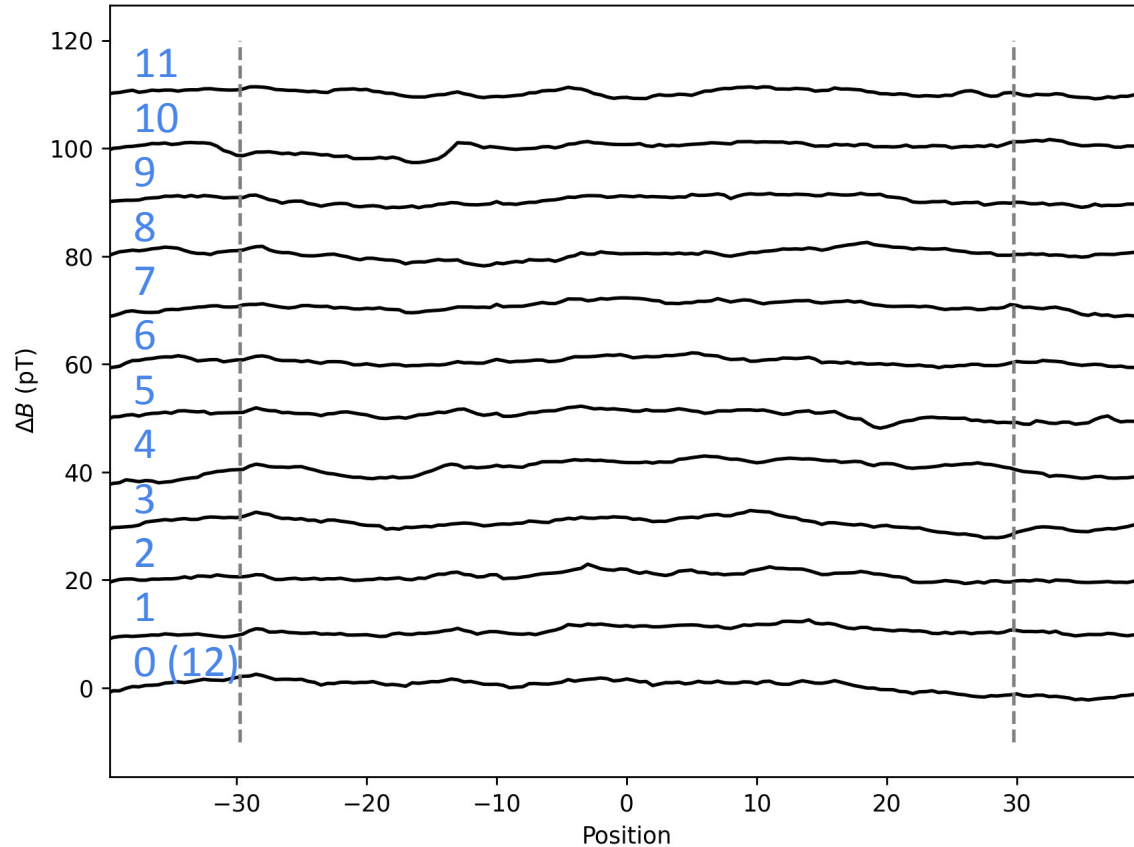

The precession chambers

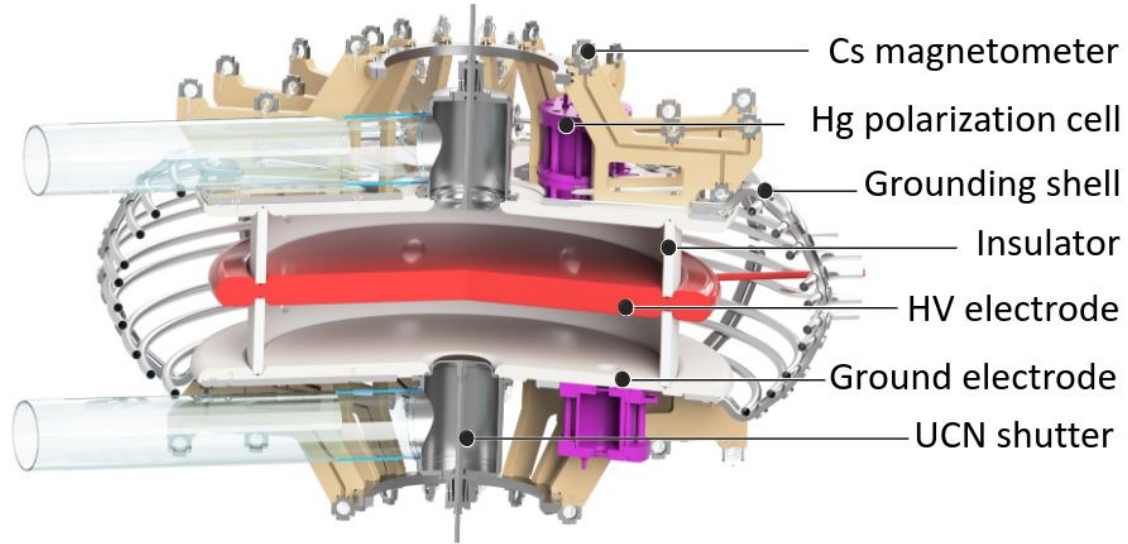



UCN transmission measurements

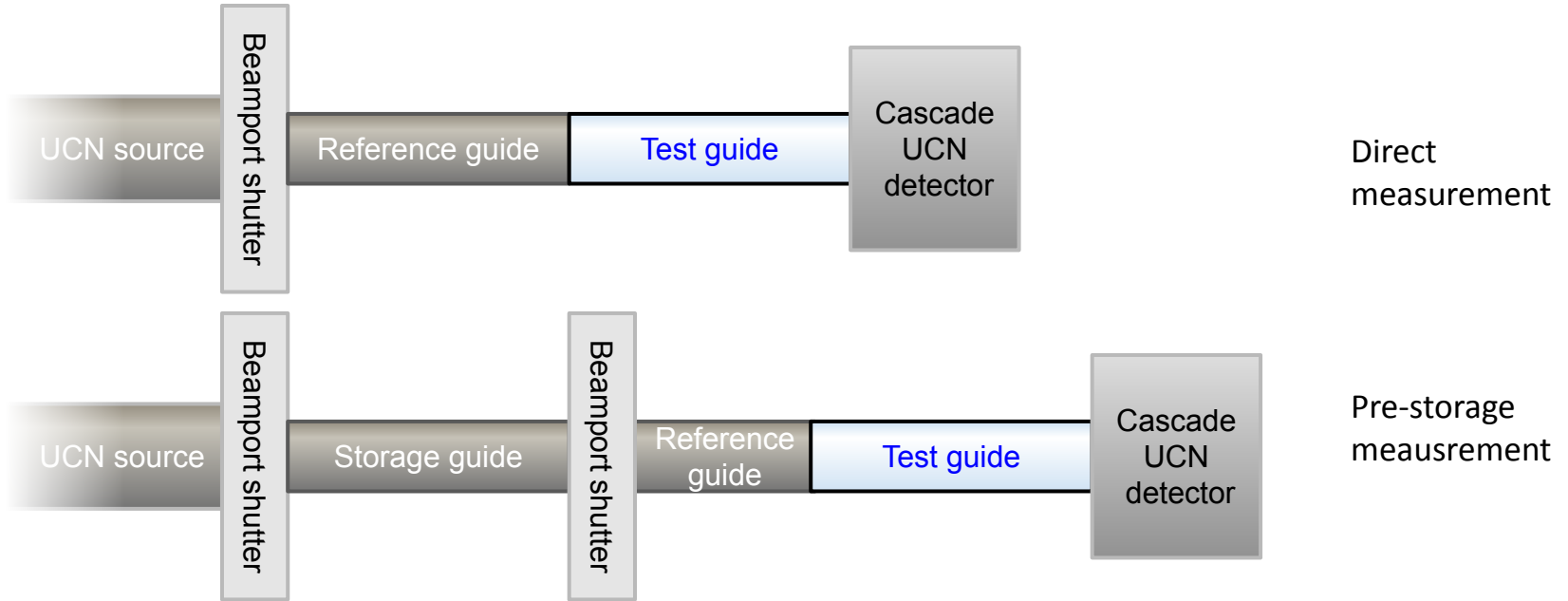

UCN transmission measurements

- Pulsed UCN source
 - 8 s proton beam on spallation target
 - UCN production
 - Fill storage volume
 - Drain into experiment
- Region of interest: 12-200s
 - not all neutrons before 12s are storable
- Normalisation using second beam port at same height

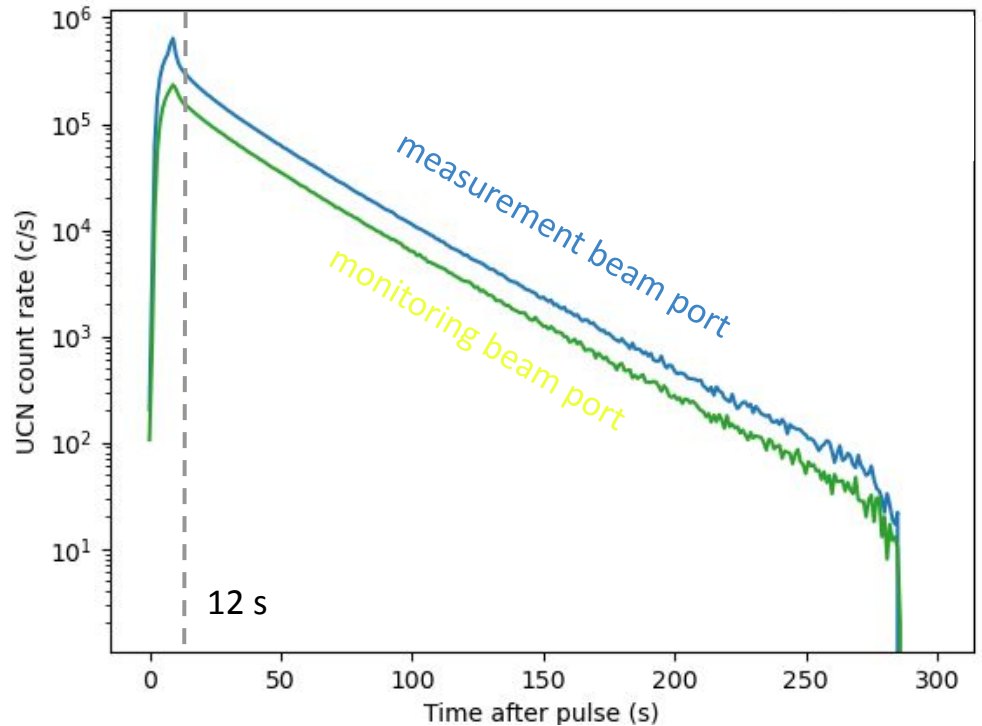

Requirements for UCN guides

- 90% transmission, normalised to 1 m
- Homogeneous magnetic field
 - Field stability (30 fT)
 - Accurate magnetometry (30 fT)
 - Limit on local magnetic impurities
 - 10 nA m²
 - 16 pT @ 5 cm

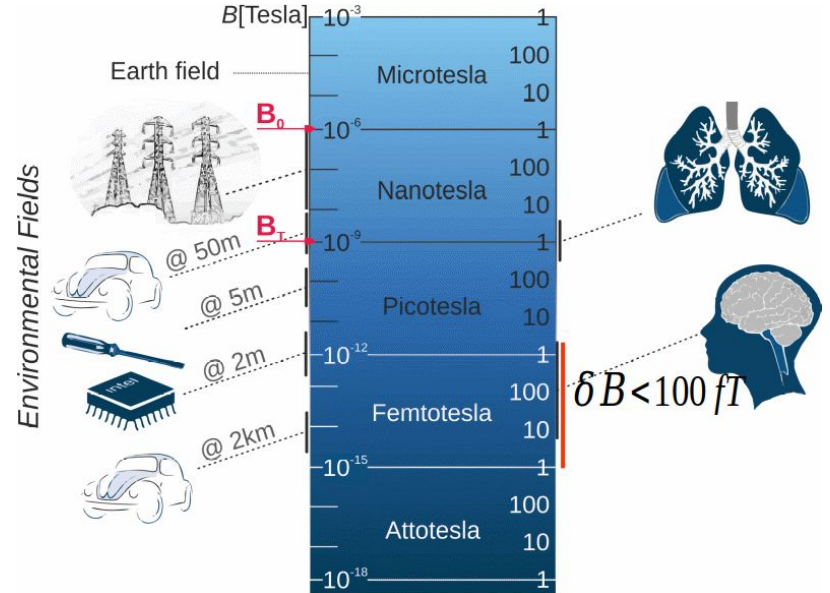

Related to statistical errors	
(B-gen) Top-Bottom resonance matching condition	$-0.6 \text{ pT/cm} < G_{1,0} < 0.6 \text{ pT/cm}$
(B-gen) Field uniformity in the chambers	$\sigma(B_z) < 170 \text{ pT}$
(B-gen) Field stability on minutes timescale	$< 30 \text{ fT}$
(B-meas) Precision Hg co-magnetometer, per cycle, per chamber	$< 30 \text{ fT}$

Related to systematical errors	
(B-gen) Gradient stability on the timescale of minutes	$\sigma(G)[5\text{min}] < 50 \text{ fT/cm}$
(B-meas) Accuracy mercury co-magnetometer per chamber	$< 100 \text{ fT}$
(B-meas) Accuracy on cubic mode (Cs magnetometers)	$\delta \dot{G}_3 < 20 \text{ fT/cm}$
(B-gen) Reproducibility of the order 5 mode	$\sigma(\dot{G}_5) < 20 \text{ fT/cm}$
(B-meas) Accuracy of the order 5 mode (field mapper)	$\delta \dot{G}_5 < 20 \text{ fT/cm}$
(B-gen) Dipoles close to the electrode	$< 20 \text{ pT at } 5 \text{ cm}$
(E-gen) Relative accuracy on E field magnitude	$< 10^{-3}$
