



AXEL- 2023: Colliders

Rende Steerenberg – BE-OP

Topics

- Why Colliders ?
- Different Types of Colliders
- The LHC Cycle and its Filling
- Luminosity, Cross Section and Events
- Crossing Angle
- Tune Shift as Result of Beam-Beam
- Collimation
- What will change for HL-LHC and LIU ?

Fixed Target v.s. Colliders

Fixed Target



$$E \propto \sqrt{E_{beam}}$$

Much of the energy is lost in the target and only part is used to produce secondary particles

Collider



$$E = E_{beam1} + E_{beam2}$$

All energy will be available for particle production

Types of Colliders

- **Single-ring collider**
 - Uses oppositely charged particles in single vacuum chamber
 - Electrons – Positrons ($e^- - e^+$)
 - Protons - Antiprotons ($p^+ - p^-$)
 - Opposite charged particles circulating in opposite directions are bent and focused along the same orbit by the same magnetic fields
 - SPS was CERN's first single-ring collider, followed by LEP (80's and 90's)
- **Twin-ring collider**
 - Two synchrotron rings, clockwise and anticlockwise, meeting at crossing points common to both rings
 - Can work with identical charged particles or even with different particle species
 - Initially with electron machine (Novosibirsk in 1965 and Stanford in 1966)
 - CERN built the first hadron collider, the ISR, with 30 GeV per beam (1971)
 - The LHC is also a twin-ring collider
- **Linear Collider**
 - Electron Colliders (e.g. CLIC, ILC)
 - High energy and circular lepton colliders have reached more or less the limit with LEP
 - Although for the Future Circular Collider study a lepton variant is being studied

The CERN Intersection Storage Ring

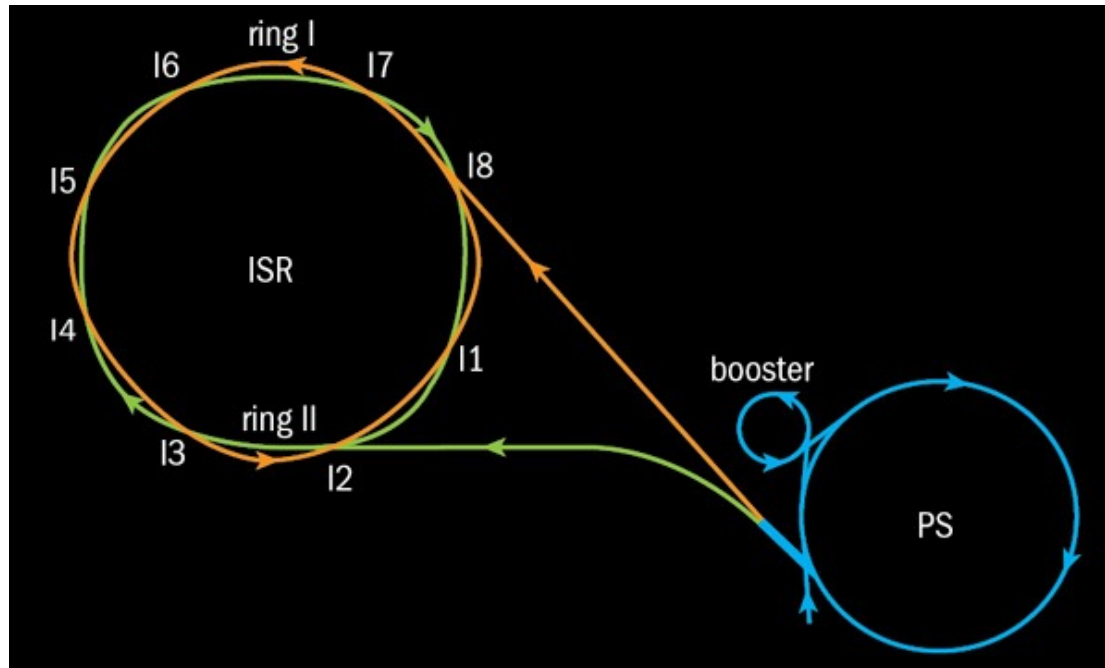

- The ISR collided beam at 30 GeV per beam
- In the ISR many hadron collider challenges were tackled and studied and have now become standard practice

Some Twin-ring ISR images

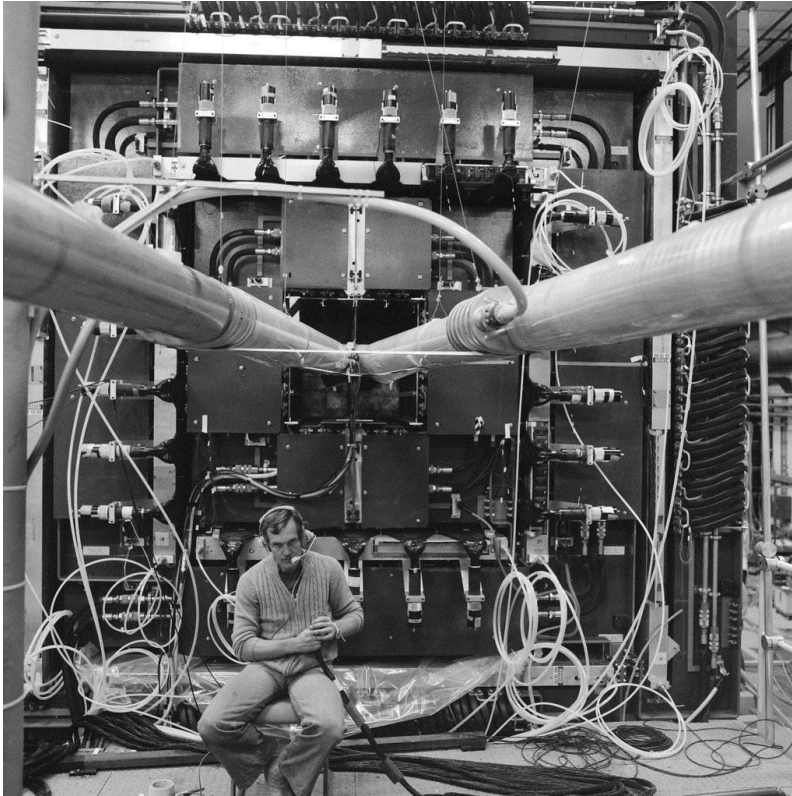

- 40 Amperes of beam current with de-bunched beam circulating

LHC a Twin-Ring Collider

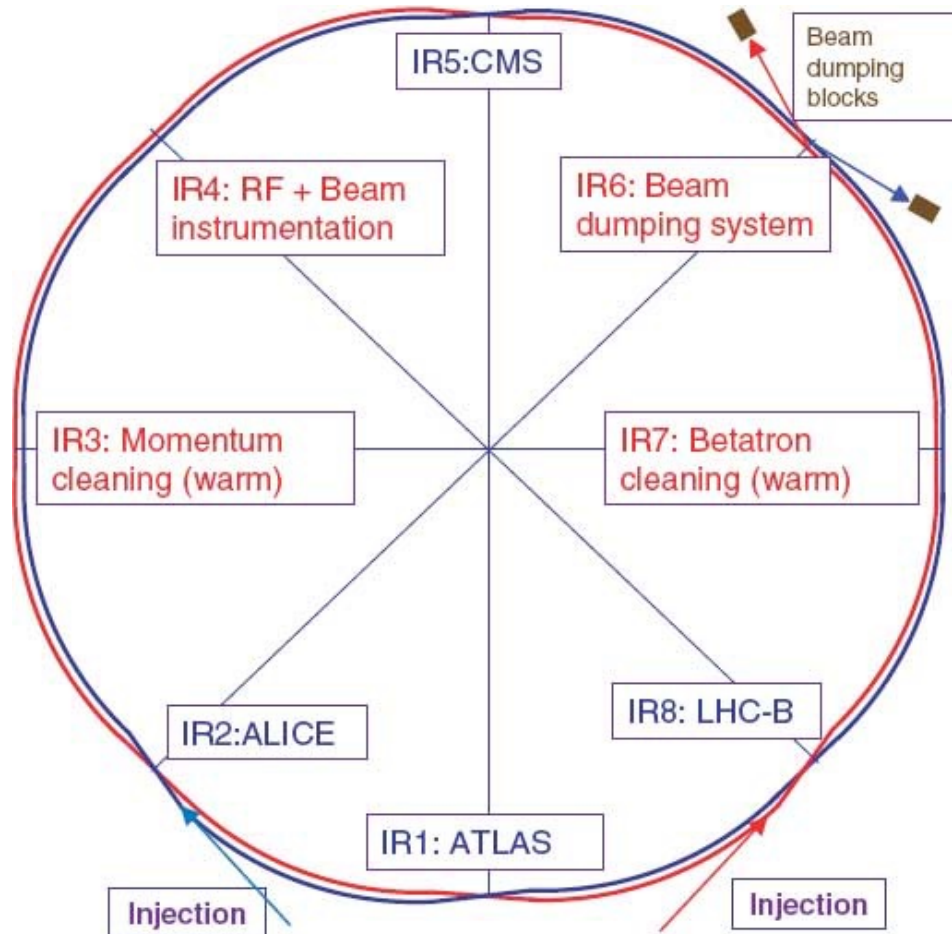

- 8 sectors / arcs
- 8 long straight section
- 2 separate vacuum chambers
- 4 beam crossing points

LHC Twin-Aperture Dipole Magnet

Magnetic field in opposite direction

Superconducting magnets, using superfluid helium as coolant

Beam pipe distance is 198 mm

Insulation vacuum

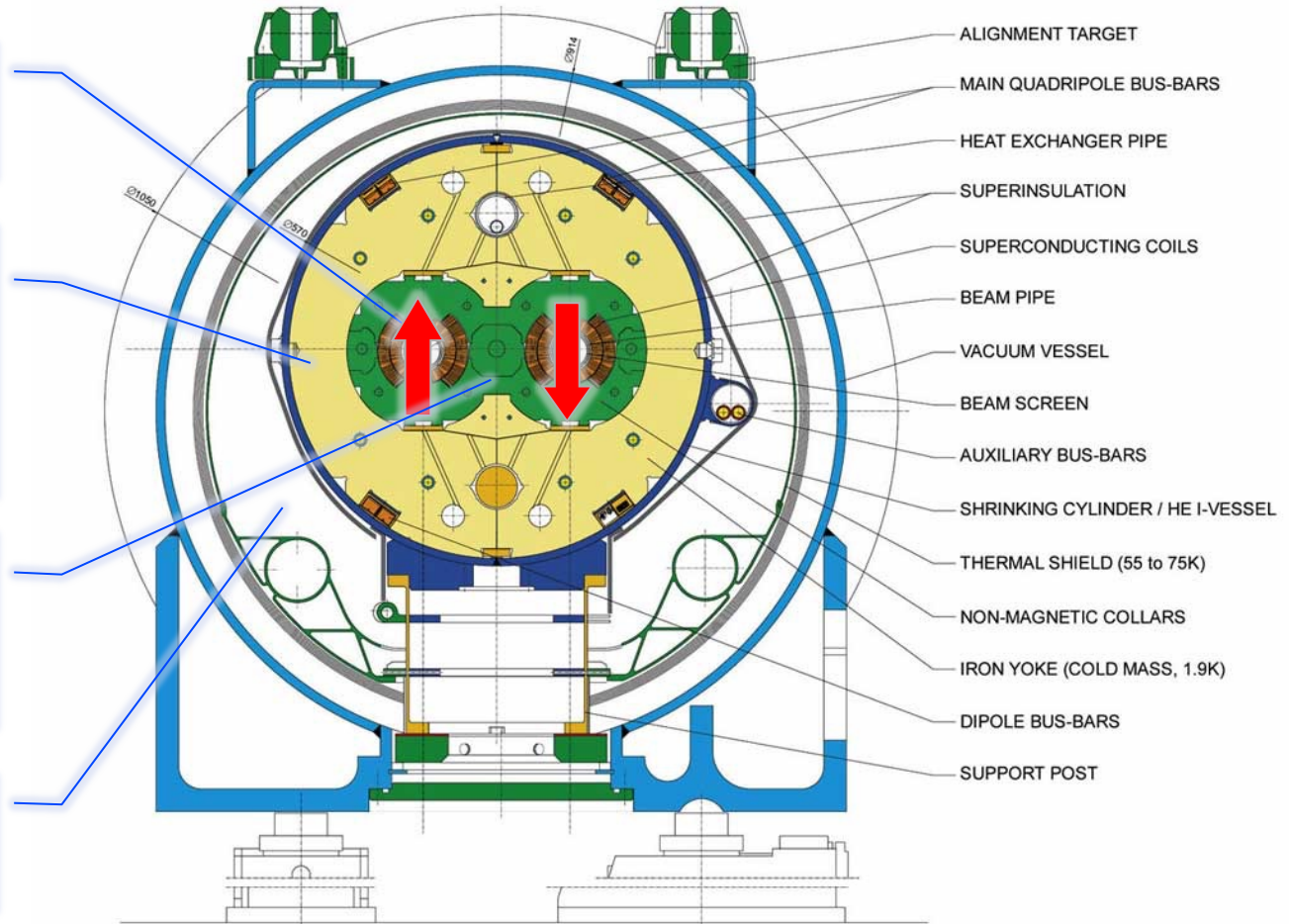

Beam Crossing in Interaction Region

- Both beams **Beam 1** and **Beam 2** have the same energy and see the same magnetic field strength, but in opposite direction
- Therefore they need to have an orbit with the same circumference

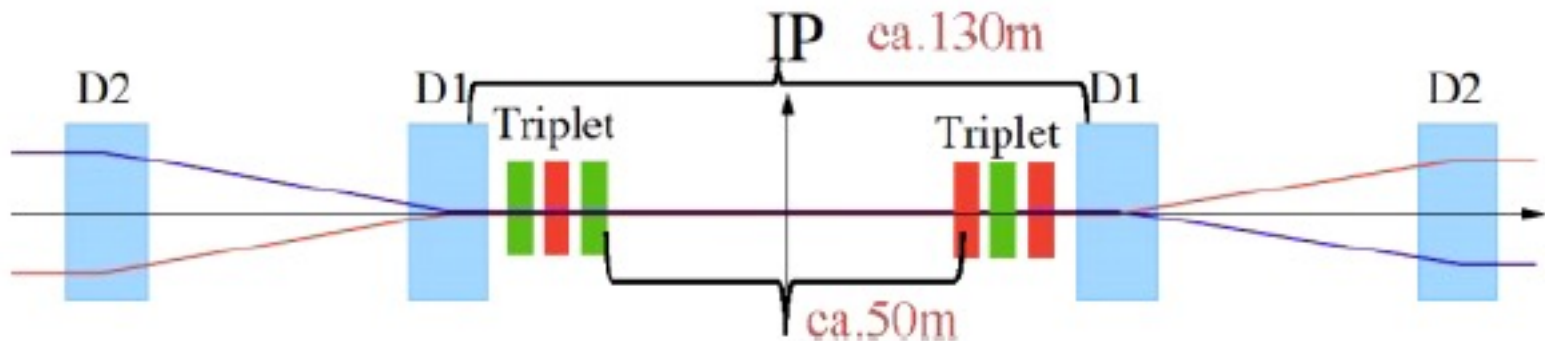

- Therefore **Beam 1** and **Beam 2** go from inner to outer ring and vice versa at the interaction points (IP)

LHC 50 & 25 ns Standard Beam Production (PS)

- The LHC cycle in the PS with 1.4 GeV injection plateau, 2.5 GeV intermediate plateau and a flat top at 26 GeV

- Triple splitting at 2.5 GeV
 - Lower space charge, Larger bucket

- Two times a bunch splitting on the 26 GeV/c flat top

- Non-adiabatic bunch rotation before extraction → 4ns bunch length (4σ)

- For 25 ns, the PSB bunch intensity is divided by a factor 12

- $$I_{\text{LHC}} = 1.2 \times 10^{11} \text{ ppb} \rightarrow I_{\text{PSB}} = 14.4 \times 10^{11} \text{ ppb}$$

- The transverse emittance determined by PSB (multi-turn injection)

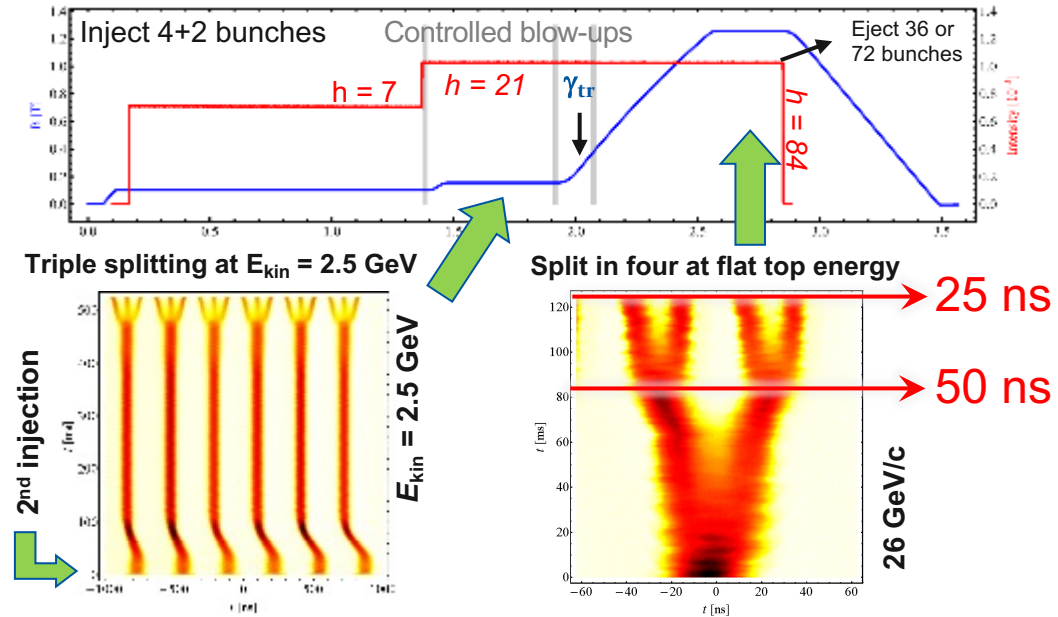

25 ns: Each PSB bunch divided by: 12 → 6 × 3 × 2 × 2 = 72
 50 ns: Each PSB bunch divided by: 6 → 6 × 3 × 2 = 36

Luminosity: The Collider Figure of Merit

- The challenge in a collider is to obtain a **high probability of collisions** in order to have many events in the experiments.
- This probability is called **luminosity**
- The actual number of events in the experiments therefore depends on the **Luminosity** and the proton **cross section**
- The total **cross section** of proton-proton interactions increases with **energy**
 - 1 barn = 10^{-24} cm² (size of Uranium nucleus)
 - 1 nanobarn (nb) = 10^{-33} cm²
 - 1 picobarn (pb) = 10^{-36} cm²
 - 1 femtobarn (fb) = 10^{-39} cm²

The formula for Luminosity

The diagram shows the formula for luminosity L with callout boxes identifying its components:

- Number of colliding bunches**: n_b
- Revolution frequency**: f_{rev}
- Beam 1 intensity**: N_1
- Beam 2 intensity**: N_2
- Horizontal beam size**: $\sigma_{x,1}$ and $\sigma_{x,2}$
- Vertical beam size**: $\sigma_{y,1}$ and $\sigma_{y,2}$
- Geometrical reduction factors**: $F \cdot H$

$$L = \frac{f_{rev} \cdot n_b \cdot N_1 \cdot N_2}{2\pi \sqrt{(\sigma_{x,1}^2 + \sigma_{x,2}^2)} \cdot \sqrt{(\sigma_{y,1}^2 + \sigma_{y,2}^2)}} \cdot F \cdot H$$

- L is expressed in $\text{cm}^{-2} \text{s}^{-1}$
- At the LHC design luminosity of $1 \times 10^{34} \text{ cm}^{-2} \text{ s}^{-1}$ and with a proton-proton cross section of $1 \times 10^{-33} \text{ cm}^2$ and design beam parameter we would produce 10 events per second
- In 2018 we went up to $\sim 2 \times 10^{34} \text{ cm}^{-2} \text{ s}^{-1}$
- The experiments can cope with ~ 50 event per bunch crossing.

Luminosity burn-off & levelling

- When the beams just enter in collision the luminosity is the highest.
- Each proton that collides leaves a 'hole', which means that the beam brightness decreases, hence the luminosity decreases
- This phenomena is called **Luminosity burn-off**
- The peak luminosity can cause too many events
- This is called **Pile-up**
- In these cases we can apply luminosity levelling
 - Separate the beams
 - Modulate the β^*
- Should provide about the same integrated luminosity with less pile-up

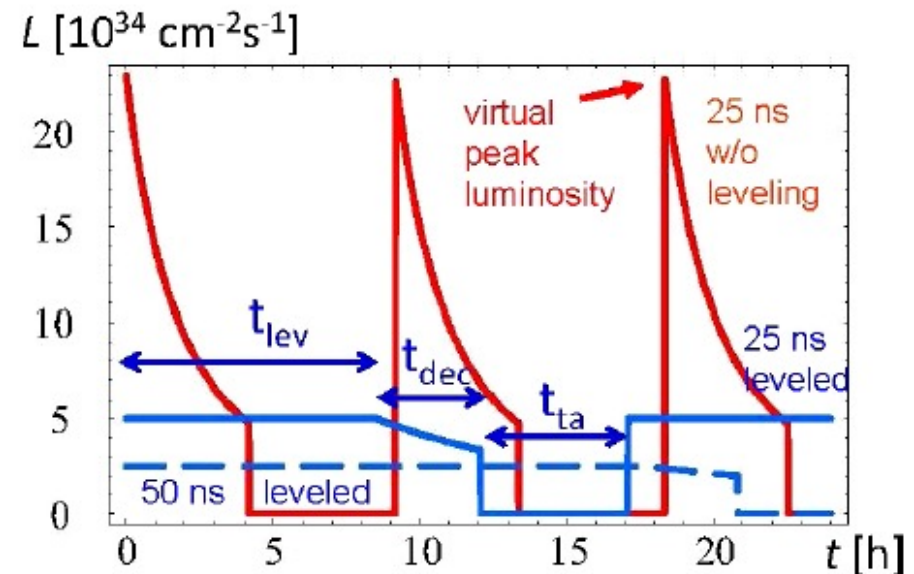

Integrated Luminosity

- The **integrated luminosity** is the peak luminosity multiplied by the time the beams were in collision, corrected by the burn-off and the turn-around

$$L_{\text{int}} \approx HL_{\text{peak}}T_{\text{phys}}$$

- H = Hübner factor which contains the burn-off correction and the turn around time from fill to the next
- Peak or instantaneous luminosity
→ $1 \times 10^{-34} \text{ cm}^{-2} \text{ s}^{-1}$ (design value)
- Integrated luminosity unit is fb^{-1}
(inverse femtobarn)
- In 2018 we managed 66 fb^{-1}

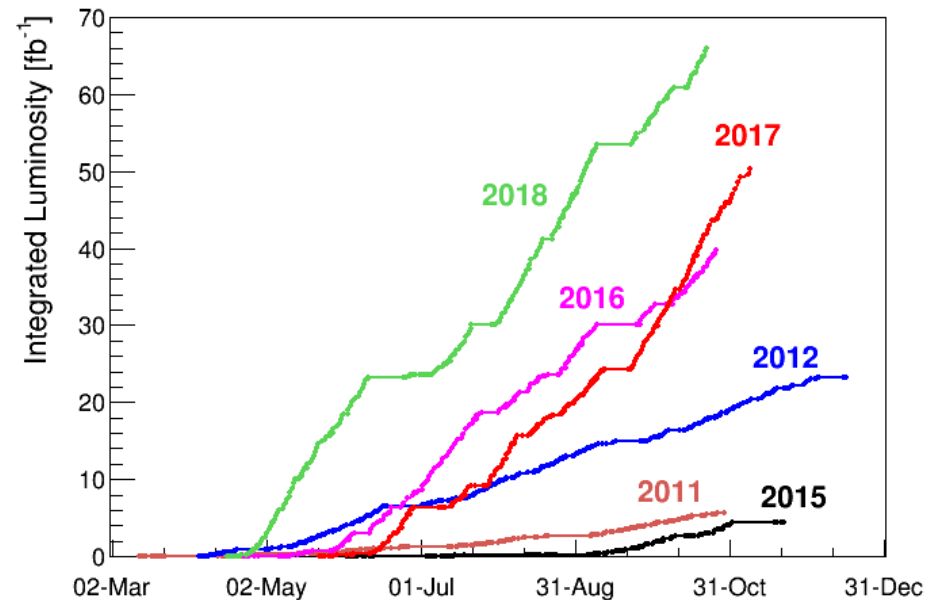

Crossing angle

- In the interaction regions the beam crosses and collides with an angle.
- This crossing angle will lead to a luminosity loss which is caused by the increase of the effective transverse beam size

$$L = \frac{f_{rev} \cdot n_b \cdot N_1 \cdot N_2}{2\pi \sqrt{(\sigma_{x,1}^2 + \sigma_{x,2}^2)} \cdot \sqrt{(\sigma_{y,1}^2 + \sigma_{y,2}^2)}} \quad (F) \quad H.$$

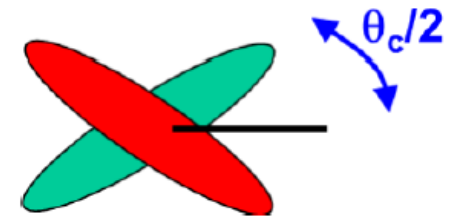

- The Luminosity loss is described by:

$$R_\phi = \frac{1}{\sqrt{1 + \phi^2}} \quad \text{where} \quad \phi \equiv \frac{\theta_c \sigma_z}{2\sigma_x}$$

Beam-Beam Effect

- When two beams collide, they interact
 - Elastic and inelastic collisions between particles → desired
 - Other electromagnetic interactions → undesired

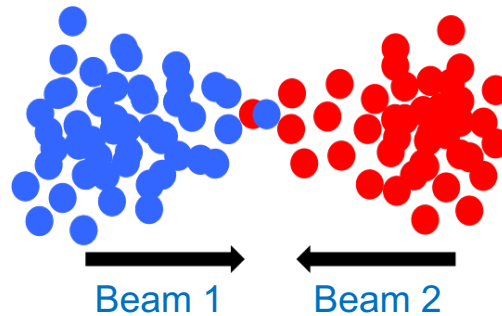

- The particles in one bunch act like an electromagnetic lens on the others in the bunch and can change the beam parameters
 - The forces from one beam on another are non-linear
 - We cannot avoid the beams exerting forces on each other
 - This can have a detrimental effect, and can lower the luminosity

Beam-Beam Effect

- Particle beams are surrounded by magnetic fields
- If the beams “see” each other in colliders these magnetic fields can act on the both beams and can cause tune shifts
- There are two types of interactions to be considered
 - Long range (parasitic encounters)
 - Short-range (head-on)

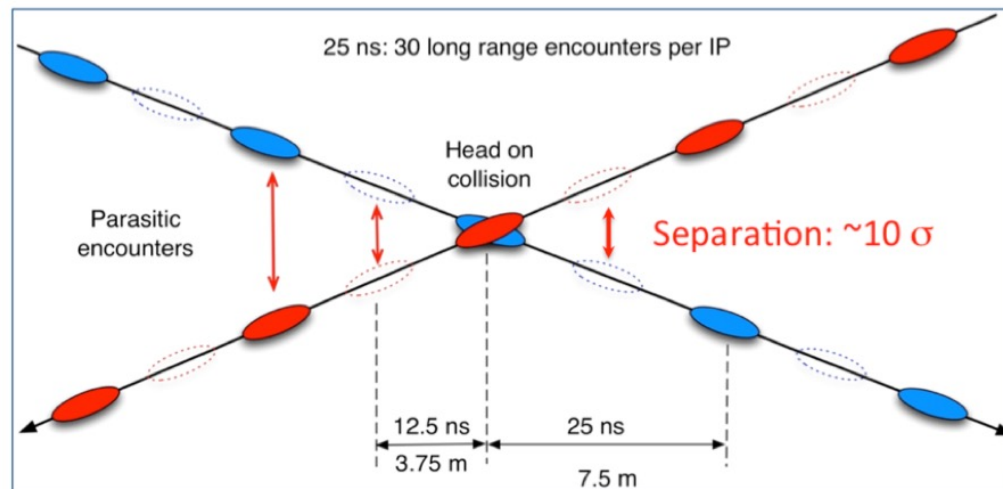

Short Range

- Beam-beam force or kick:
 - Small amplitudes \rightarrow linear force \rightarrow large tune shift (quadrupole-like)
 - Large amplitude \rightarrow non-linear force \rightarrow smaller amplitude dependent tune shift
- These forces can slightly modify the β -function and cause β -beating (modulation of the β -function)
- For round beams we characterise the effect by the beam-beam parameter:

$$\xi = \frac{Nr_0\beta^*}{4\pi\gamma\sigma^2}$$

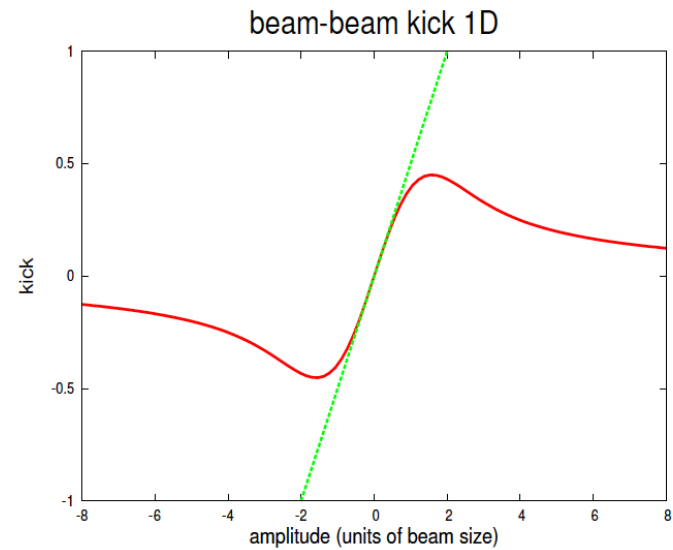

Long Range Beam-Beam Interaction

- In the LHC we locally separate the beams in the interaction regions with a crossing angle
- The larger the crossing angle the smaller the long-range beam-beam effect, but also lower luminosity

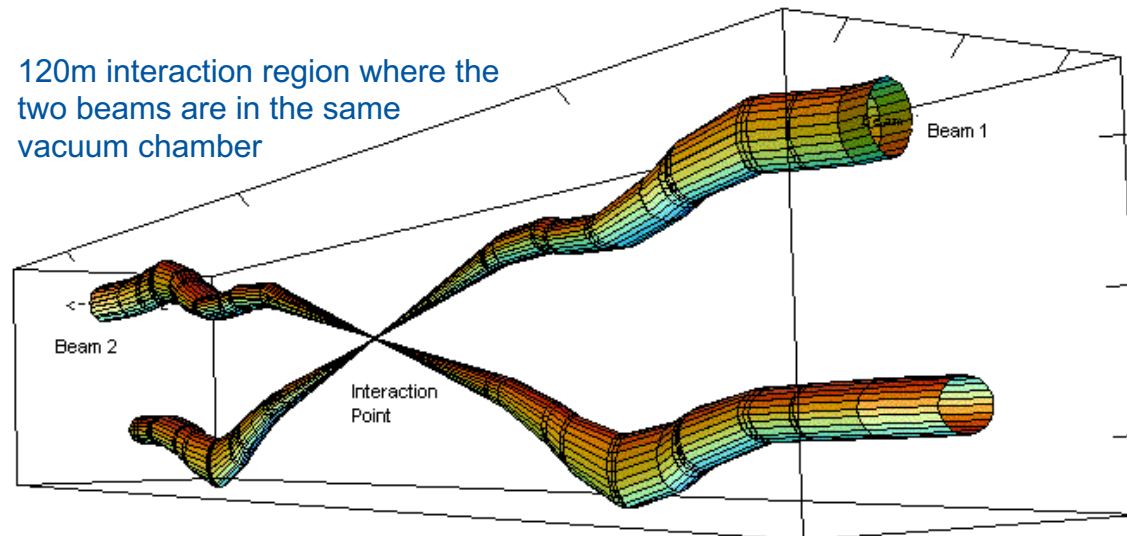

Relative beam sizes around IP1 (Atlas) in collision

LR Beam-Beam Compensation Wires

- For HL-LHC Beam beam effect takes place in areas where the two beams share the same vacuum chamber → Interaction regions

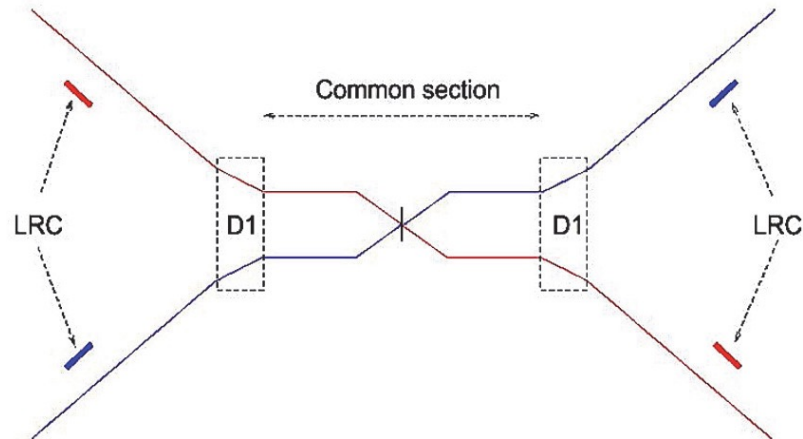

- By adding wires next to the beam through which a current flows a part of the long-range beam-beam effect can be compensated

Electron Cloud

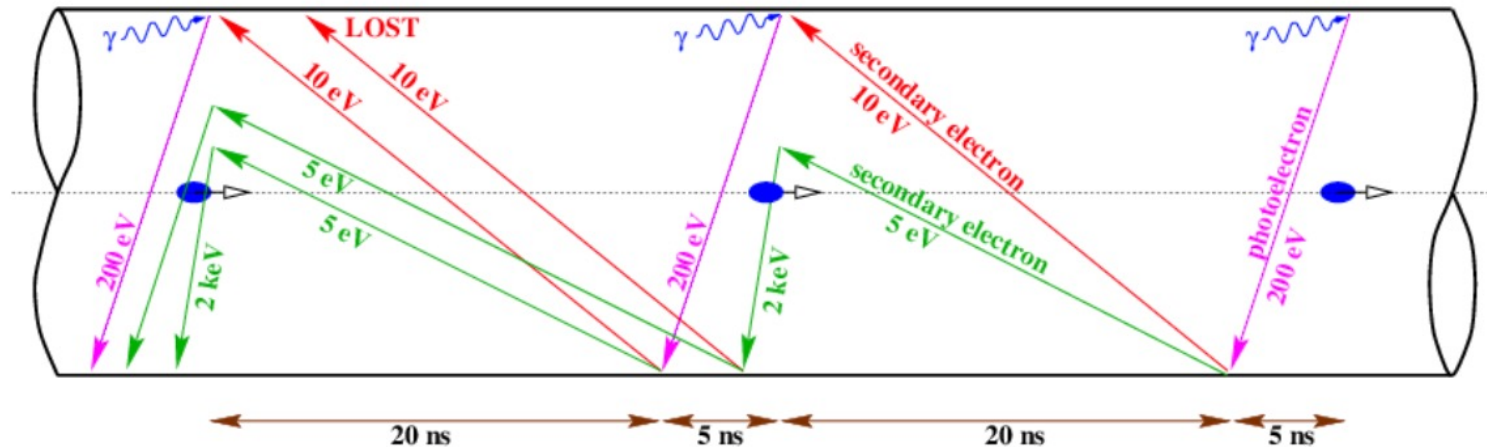

- e-cloud when secondary electron emission yield (SEY) of vacuum chamber is beyond 2, hence it depends on the vacuum chamber surface
- The electron cloud forms an impedance to the beam and can cause
 - Beam instability
 - Beam emittance growth
 - Beam losses
- e-cloud can cause severe dynamic vacuum bumps

An Effects of Electron Cloud

- Increasing emittance growth along the batch of 25 ns bunches
- Sustained loss of intensity along the batch of 25 ns bunches for the whole cycle
- It also causes an extra heat load to the cryogenic system

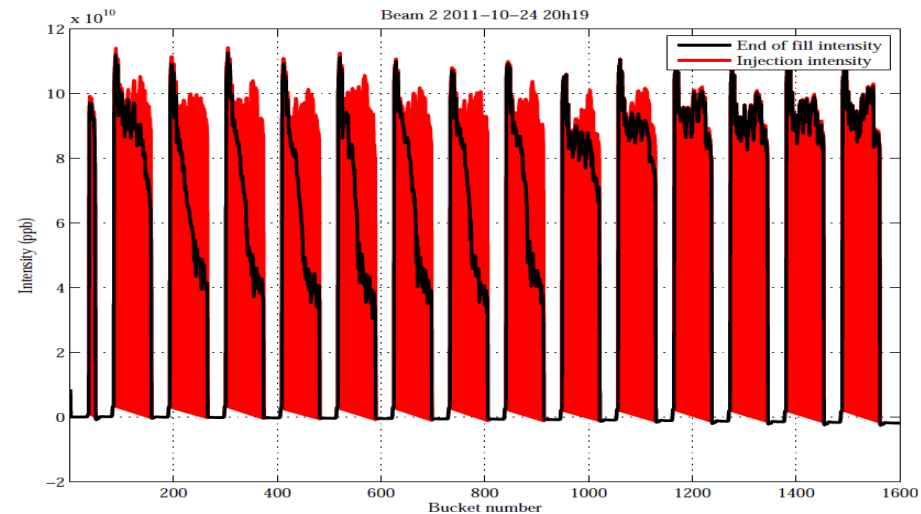
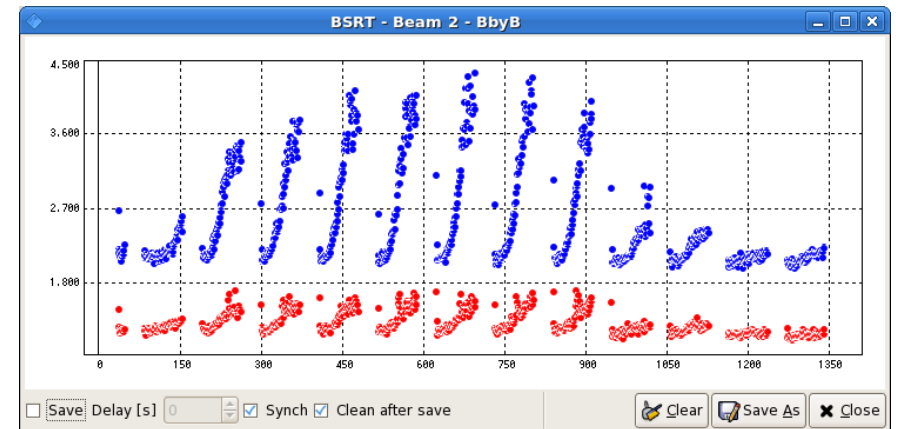

Mitigation measures

- In the SPS and the LHC we use the “scrubbing” method to reduce the SEY
- During the long shutdown (LS2) part of the SPS vacuum chambers will be carbon coated to reduce the SEY



Need for Collimation (protection)

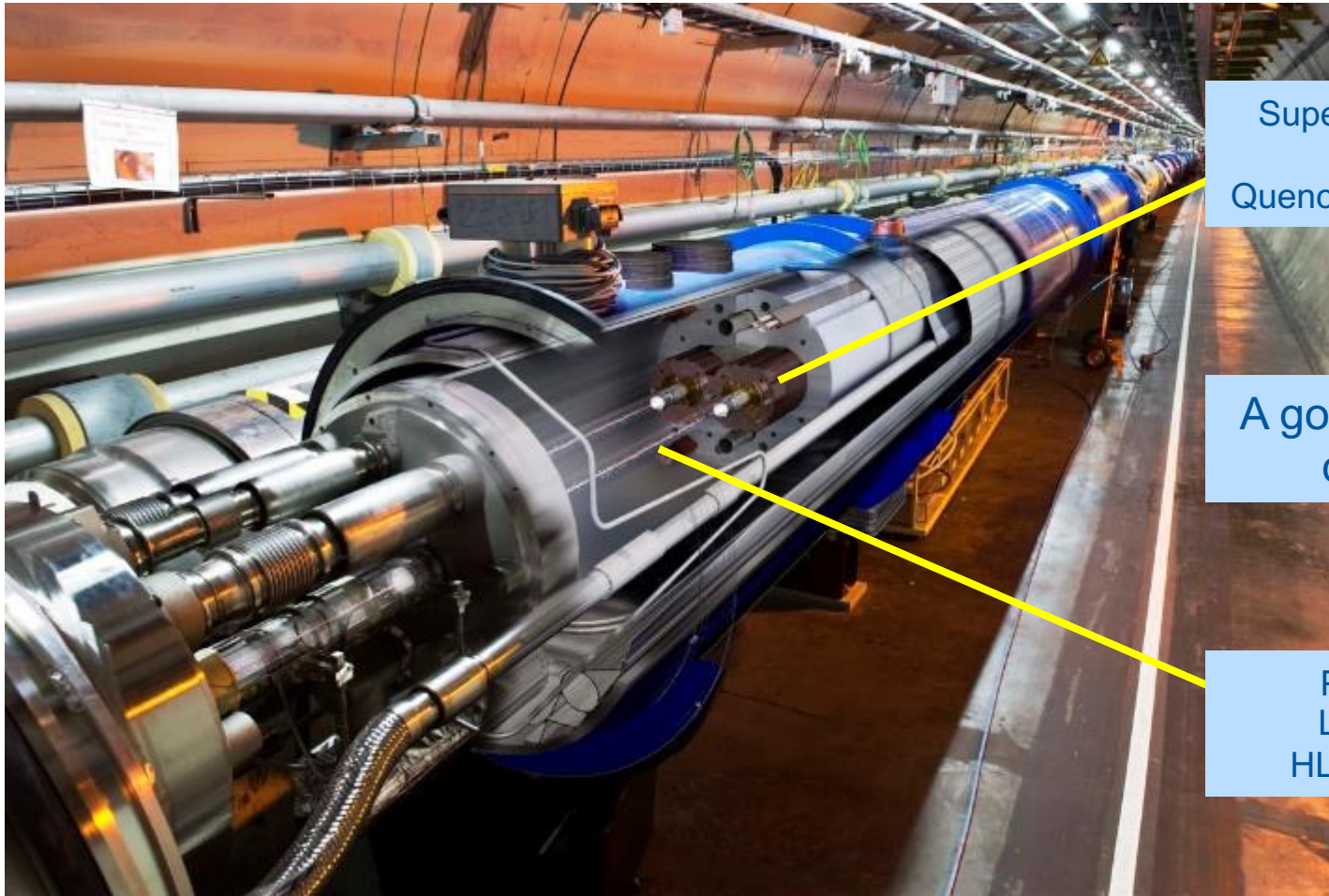

Superconducting coil
 $T = 1.9 \text{ K}$
Quench limit $\sim 15 \text{ mJ/cm}^3$



A good factor 10^{10}
difference



Proton beam
LHC: 330 MJ
HL-LHC: 500 MJ

Collimation System

- Collimation is there to remove the halo (large Betatron amplitude) particles from the beam
 - Those halo particles are susceptible to be lost in the superconducting magnets

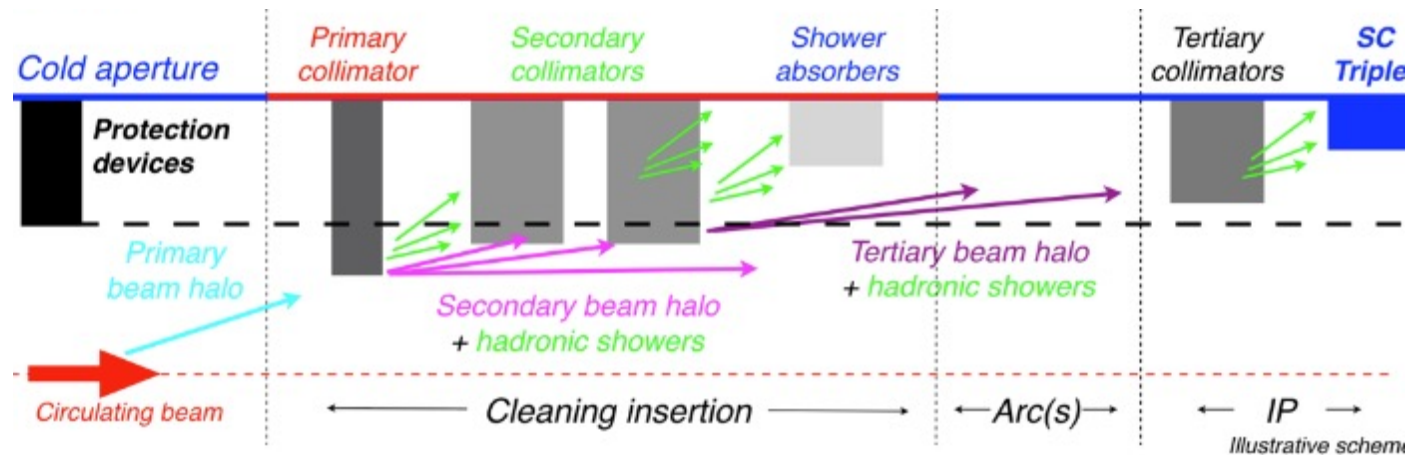

- The collimator jaws have to follow the adiabatic damping of the beam size and remain centered around the beam

Q3: Betatron & Momentum Cleaning

- In order to enhance the efficiency of the cleaning would you want or need to do something special on the machine optics in the area of the collimators?

Q3: Betatron & Momentum Cleaning

- In order to enhance the efficiency of the cleaning would you want or need to do something special on the machine optics in the area of the collimators?

- Put the horizontal betatron cleaning in areas where the β_h is large

$$\sigma_x = \sqrt{\beta_x \varepsilon}$$

- Put the vertical betatron cleaning in areas where the β_v is large

$$\sigma_y = \sqrt{\beta_y \varepsilon}$$

- Put the momentum cleaning there where the dispersion is large

$$\frac{\Delta x}{x} = D(s) \frac{\Delta p}{p}$$

Collimators

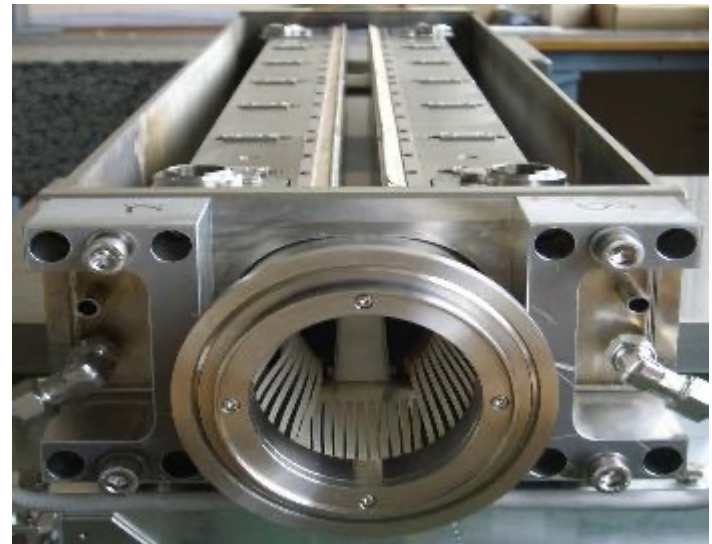
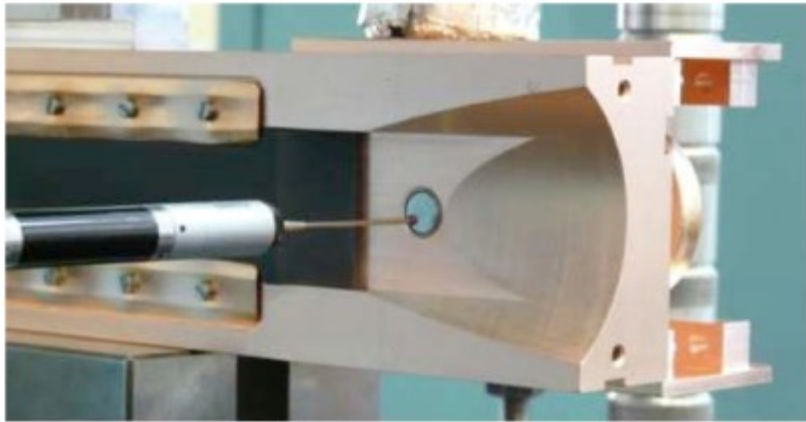
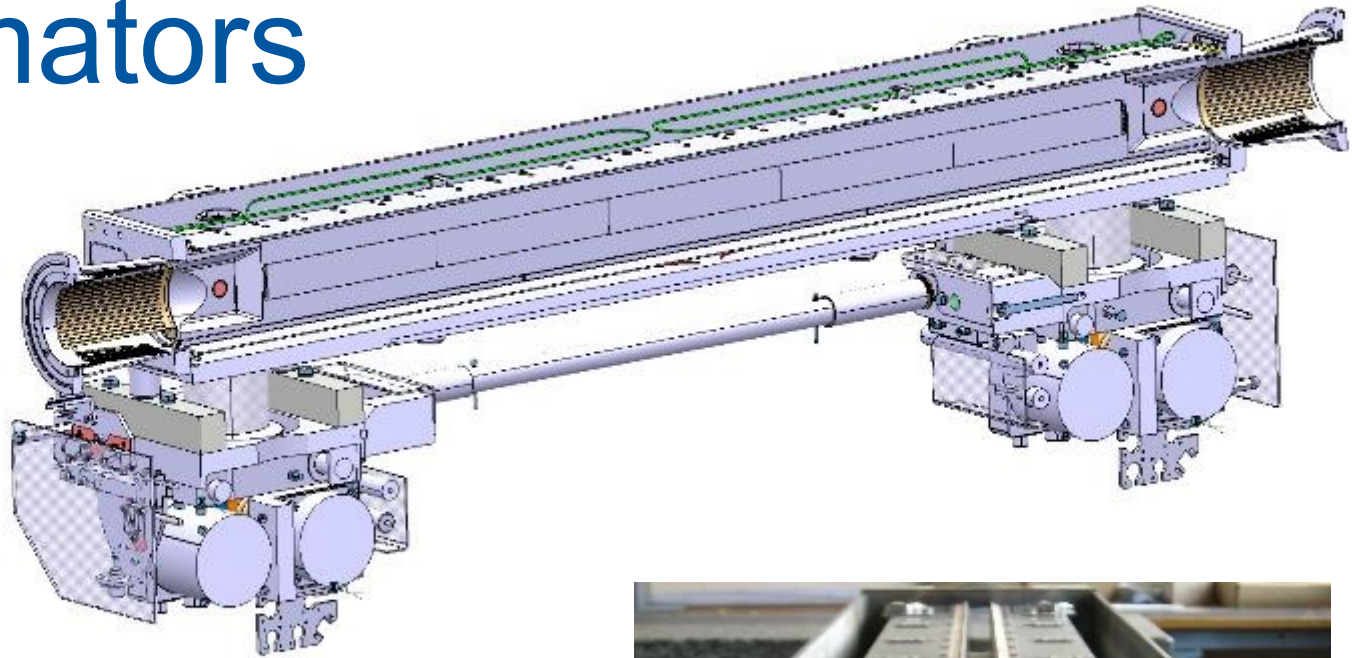

Machine Protection system

- In the 2008 incident an electrical arc released 600 MJ
- There was no beam in the machine !

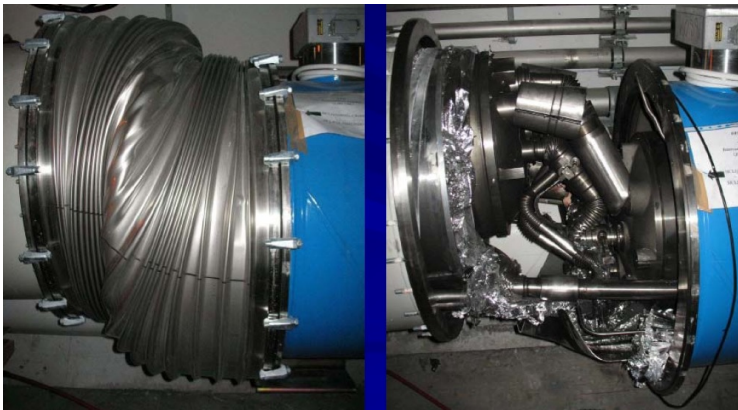
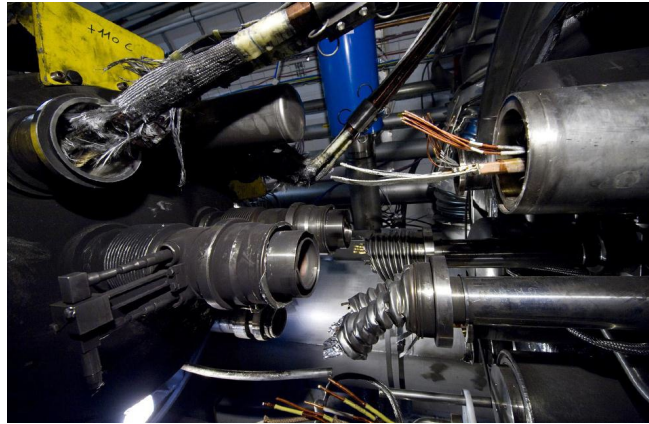

Machine Protection System

- This happened despite the presence of an already sophisticated machine protection systems



Interlocking & Beam Dumping

- Improved magnet quench protection systems and consolidated interconnections make that this is of the past.
- Nowadays nearly all type of beam instruments are used in interlocks:
 - Beam current transformer (BCT)
 - Beam Loss Monitors (BLM)
 - Beam Position Monitors (BPM)
- But also power converters etc.
- The interlock system triggers the beam dump system

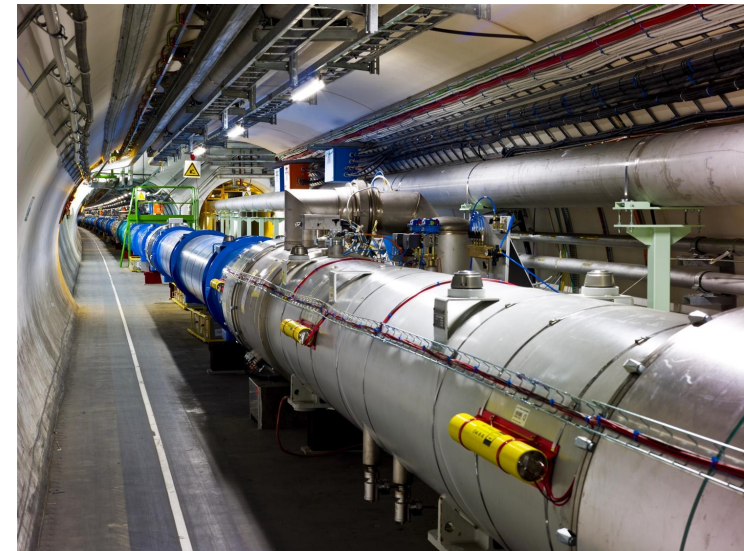

LHC Beam Dump System Layout

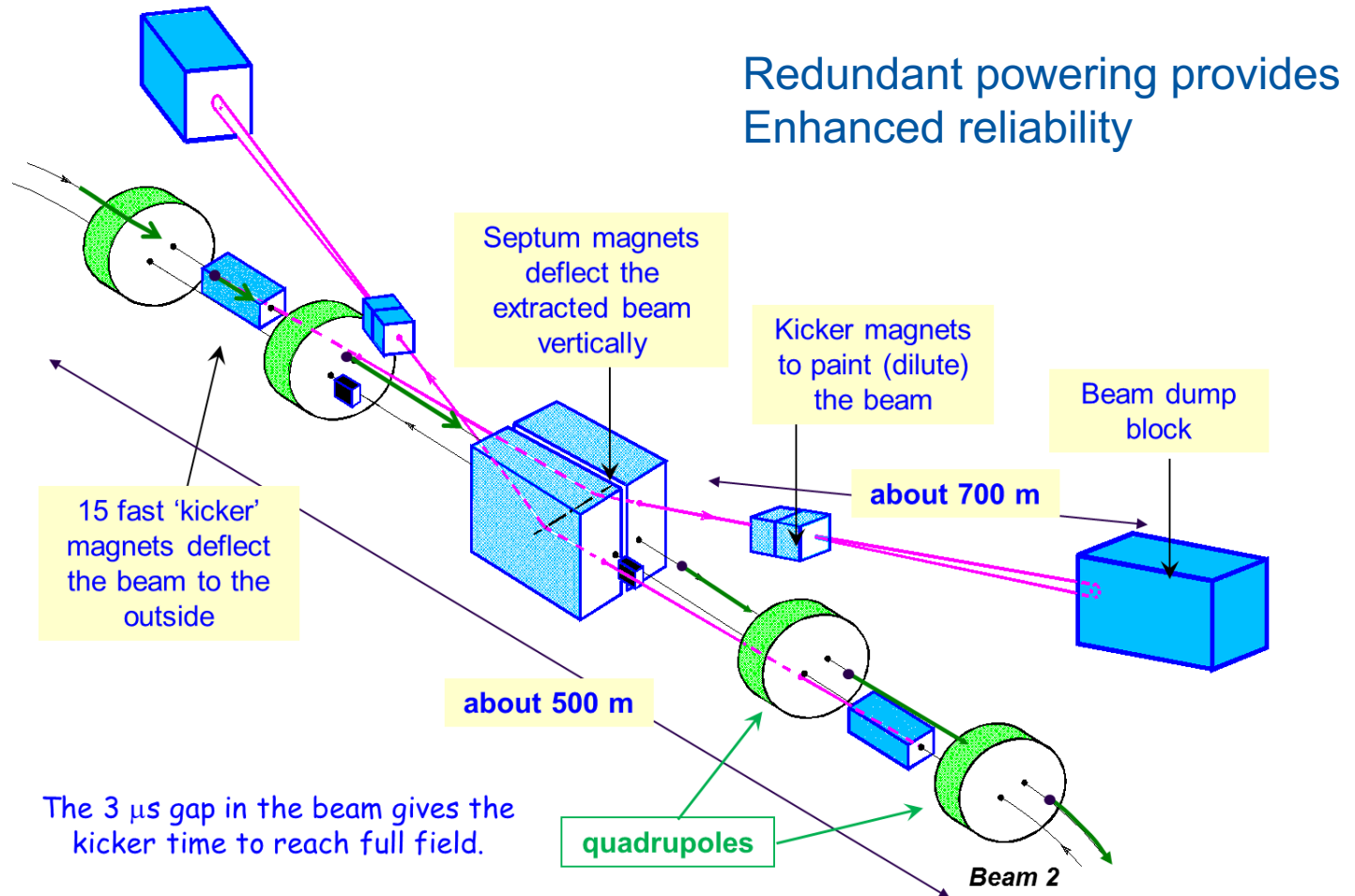

LHC Beam Dump

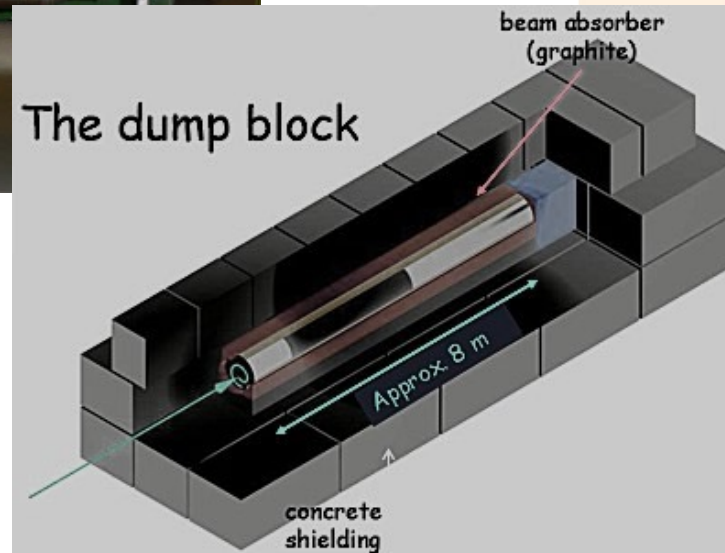
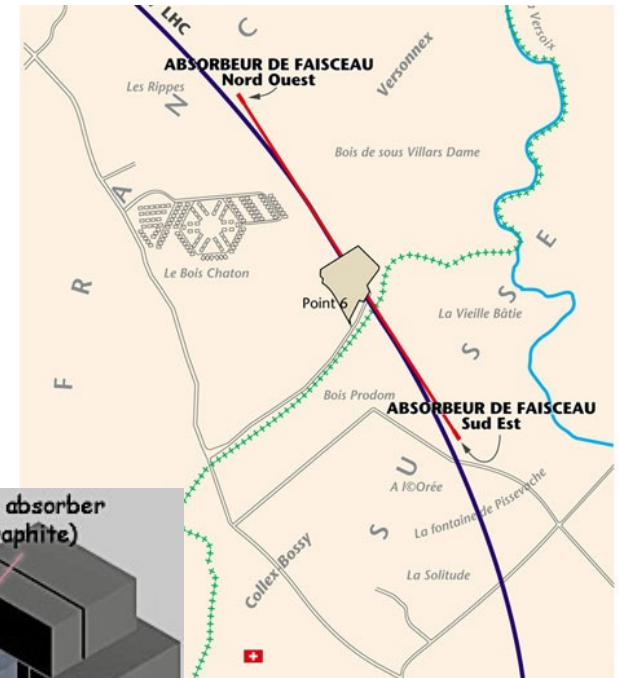
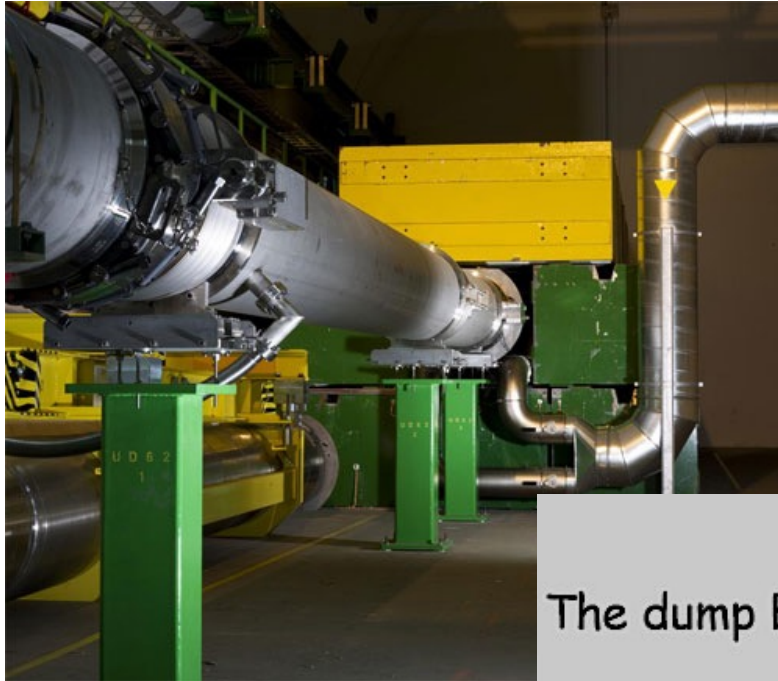

CERN AC - EH-6 - 03 1997

The Beam Dump on “LHC Page 1”

LHC Page1 Fill: 4720 E: 6501 Z GeV t(SB): 00:00:00 13-12-15 13:12:13

ION PHYSICS: BEAM DUMP

Energy:	6501 Z GeV	I(B1):	1.18e+09	I(B2):	0.00e+00
---------	------------	--------	----------	--------	----------

BTVDD.689339.B1 Updated: 13:09:54

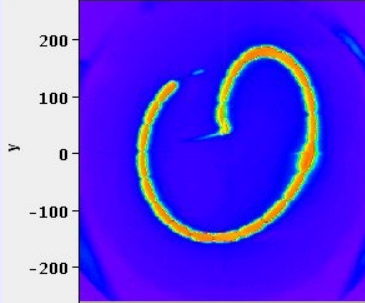

x y

BTVDD.629339.B2 Updated: 13:09:54

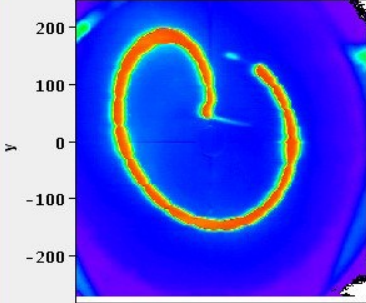

x y

Comments (13-Dec-2015 13:11:37)	BIS status and SMP flags	
Last Stable Beams for 2015!		
	Link Status of Beam Permits	B1 B2
	Global Beam Permit	true true
	Setup Beam	false false
	Beam Presence	false false
	Moveable Devices Allowed In	false false
	Stable Beams	false false

AFS: 100_150ns_518Pb_516Pb_492_444_24_22inj PM Status B1 ENABLED PM Status B2 ENABLED

HL-LHC & LIU: What Has and Still Will Changed

Luminosity, the Figure of Merit

$$LUMINOSITY = \frac{N_{event}/sec}{\sigma_r} = \frac{N_1 N_2 f_{rev} n_b F}{4\pi\sigma_x\sigma_y}$$

Intensity per bunch (points to $N_1 N_2$)
Number of bunches (points to n_b)
Geometrical Correction factors (points to F)
Beam dimensions (points to $\sigma_x \sigma_y$)

- More or less fixed:
 - Revolution period
 - Number of bunches

- Parameters to optimise:
 - Number of particles per bunch
 - Beam dimensions
 - Geometrical correction factors

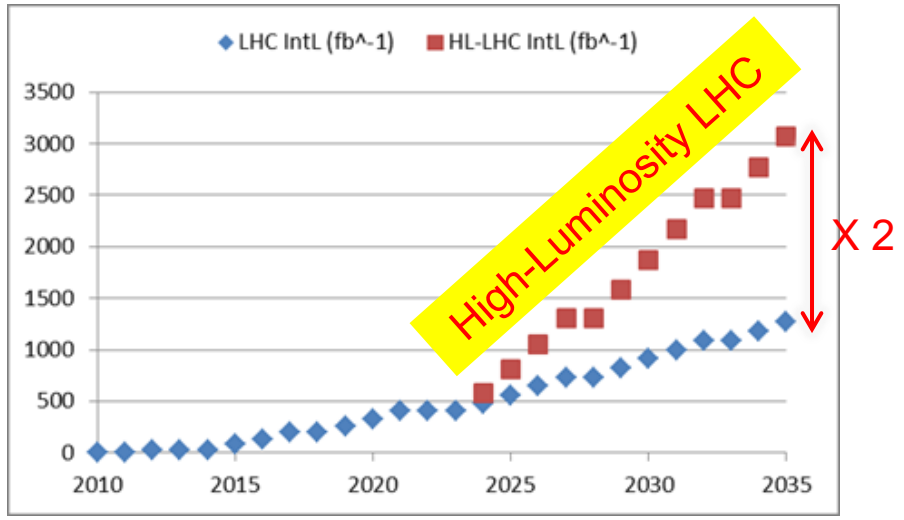

LIU: What has changed ?

- LINAC4 – PS Booster:
 - New LINAC 4 with H^- injection
 - Higher injection energy
 - New Finemet® RF cavity system
 - Increase of extraction energy
- PS:
 - Injection energy increase from 1.4 GeV to 2 GeV
 - New Finemet® RF Longitudinal feedback system
 - New RF beam manipulation scheme to increase beam brightness
- SPS
 - Machine Impedance reduction (instabilities)
 - New 200 MHz RF system
 - Vacuum chamber coating against e-cloud

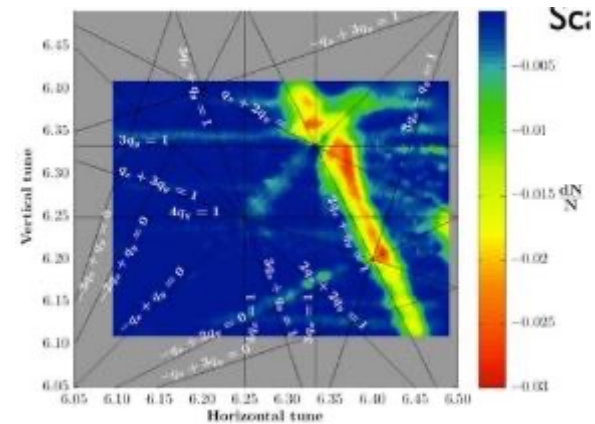

Courtesy of A. Huschauer

These are only the main modifications and this list is not exhaustive

HL-LHC: What will be changed ?

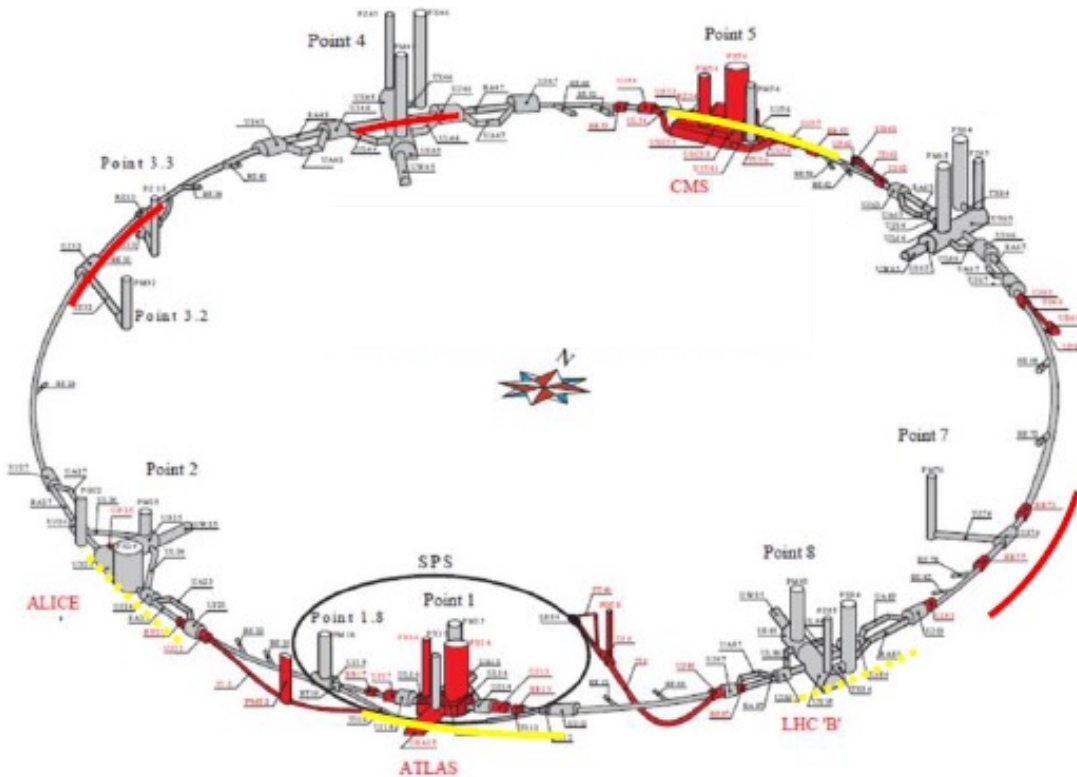

- New IR-quads (inner triplets)
- New 11T short dipoles
- Collimation upgrade
- Cryogenics upgrade
- Crab Cavities
- Cold powering
- Machine protection
- ...

Major intervention on more than 1.2 km of the LHC

These are only the main modifications and this list is not exhaustive

Crabbing to reduce crossing angle effect

- To reduce the effective transverse beam size as a result of the crossing angle we should rotate the bunch before collision and return it in its original position after collision

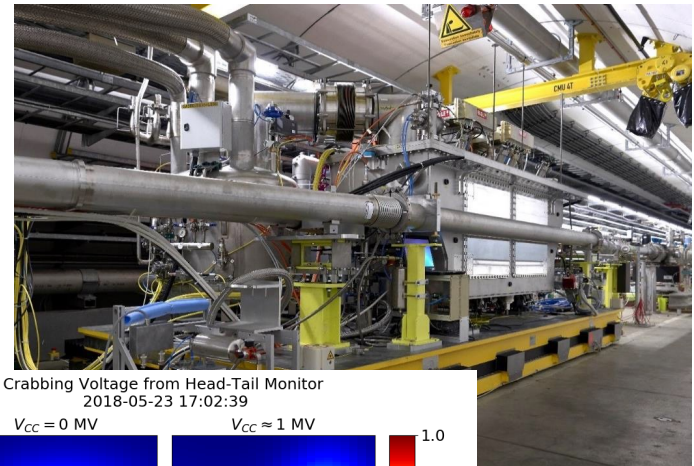
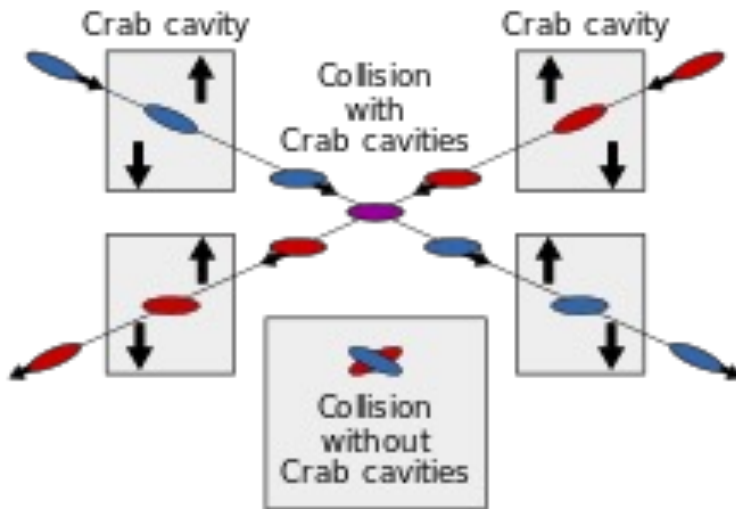

Crabbing Voltage from Head-Tail Monitor
2018-05-23 17:02:39

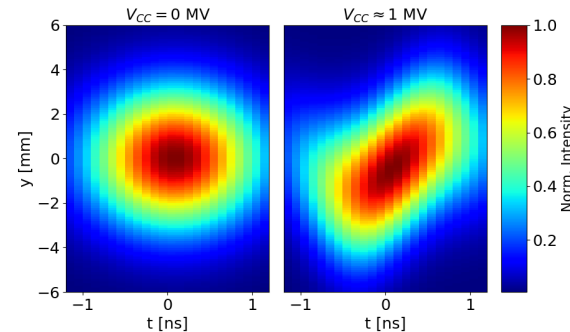

World's first crabbing on a proton beam
(23 May 2018)

Our rewarded: Very Nice and Impressive Physics Results

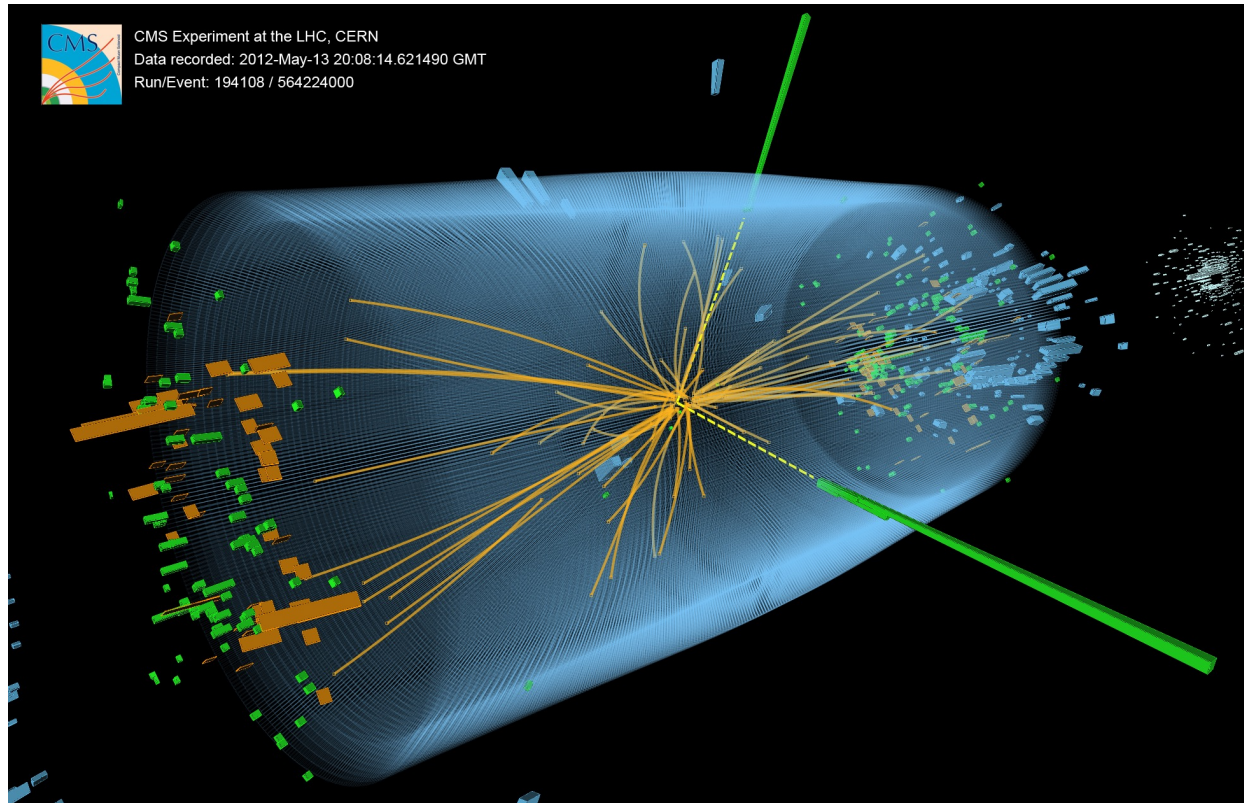

An event recorded with the CMS detector in 2012 at a proton-proton center-of-mass energy of 8 TeV.

The event shows characteristics expected from the decay of the SM Higgs boson to a pair of photons (dashed yellow lines and green towers). .

Any Questions ?



www.cern.ch