

Annual Meeting of the BMBF-funded Research Compound "Föderiertes Computing für die ATLAS- und CMS-Experimente am Large Hadron Collider in Run-3"



Introduction to discussion session

Albert-Ludwigs-Universität Freiburg

Markus Schumacher
27. February 2023

Physikalisches Institut

Albert-Ludwigs-
Universität Freiburg

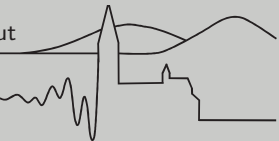

UNI
FREIBURG

Networking and cooperation in current compound

Experiment overarching:

- Close and regular cooperation of ATLAS and CMS computing experts in GridKa Overview Board, GridKa Technical Advisory Board, KET Computing&Software Panel
→ **valuable input for KET Strategy Paper on “Computing in HL-LHC Era”**
- Additional meetings at e.g. DPG spring meetings, Annual meeting of Helmholtz Alliance „Physics at th Terascale“, ...
- Close contact to ERUM-FSPs ATLAS and CMS, LHC-ERUM-FSP Office
e.g. annual FPS meetings, contribution to exhibitions at fairs („Hannover Fair“, „ISC Hamburg“)
- Regular exchange with partners of research compound FIDIUM (all partners are also patners in FIDIUM)
- Annual meeting of our compound

Do we need more regular and official meetings of this compound / or at least of group leaders?

Current funding period

Compound „Föderiertes Computing für die ATLAS- u. CMS-Experimente am Large Hadron Collider in Run-3“

Partners: AC, FR, GÖ, HH, KA, M (LMU), W Associated partners: DESY, KIT, MPP

Spokespersons M.S., Günter Quast (Deputy)

- Invest for Hardware at 5 University Tier-2-Sites (150 000 Euro per annum and site)
- Personal for operation of WLCG-Cloud and for experiment specific R&D (applied for 14 FTE)

Current funding financed from Erum-Data budget but handed in to ErUM-Pro call.

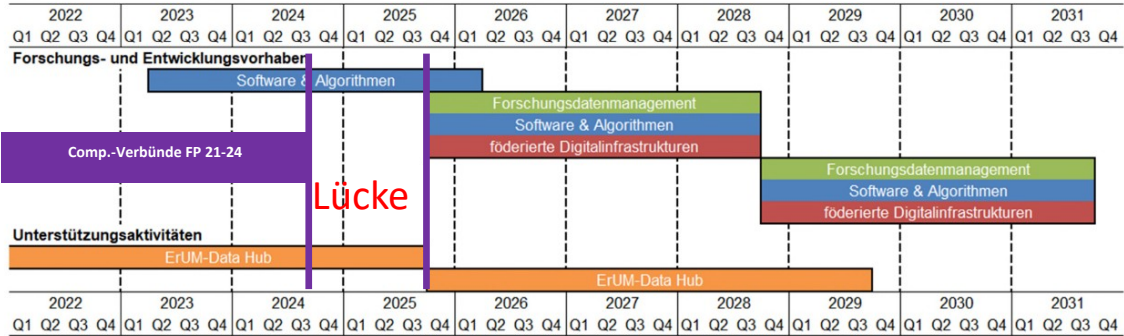

Continuos funding at least same level in area of personal undispensable

A funding gap would diminish strong expertise and may experts make leave the field

PT-DESY and BMBF are aware of the situation and will provide a solution
 At the time of the DPG spring meeting we should be informed of how to proceed

Invest for Hardware at Universities in FP 2024-2027?

According to KET Strategy Paper the preferred solution would look this

CPU time provided by NHR centres

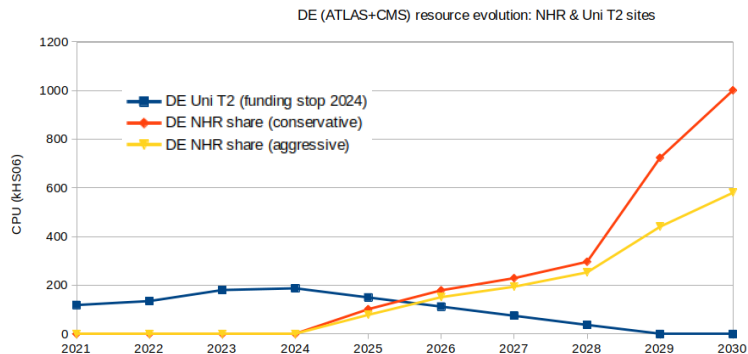

Disk mass storage provided by Helmholtz centres

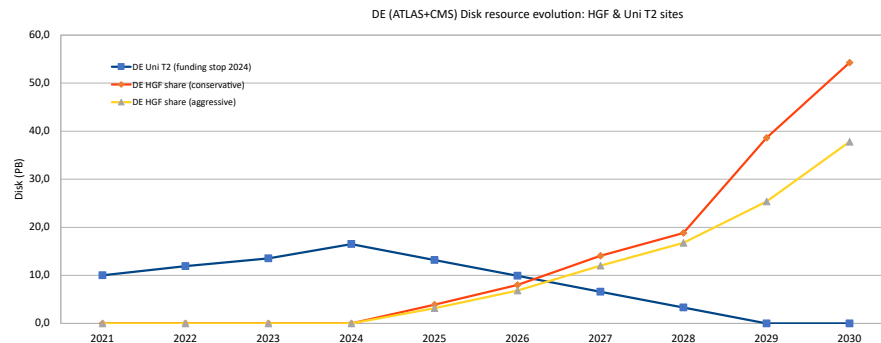

Ongoing discussions with Helmholtz Centres, NHR Association with support by BMBF and PT-DESY

Application for resources depends on timely and binding statements by the Helmholtz and NHR

For mass storage some hope to find a solution. For CPU definitely more time needed

Should foresee to apply at least for CPU resources (but maybe also for storage)

Evaluate needed budget for all scenarios (taking into account inflation and smaller technical advancement)

Maybe need also financial support for supplying sufficient power at university Ter-2 sites

Operation of WLCG-Cloud and experiment specific F&E

- Personal at least at same level will be needed for successful and efficient operation of WLCG cloud
- Co-financed positions at GridKa for experiment specific tasks at GridKa of high importance
- Probably additional personal for integration of NHR centres in experiment specific workflows needed

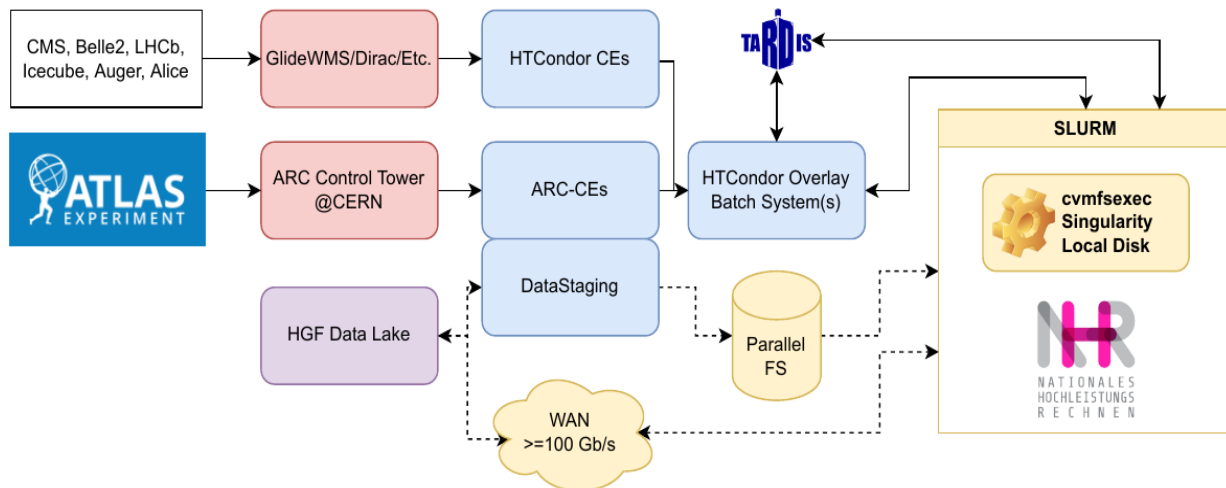

G. Duckeck, M. Giffels, T. Kuhr

- Extension of compound to all LHC experiments and Belle-2 not foreseen
- 2 FTE for core software developments in ATLAS (in-kind contribution to M&O-A) may be moved back to „normal“ FSP ATLAS applications

New compound

➤ Same partners as in running project:

Aachen, Freiburg, Göttingen, Hamburg, KIT, Munich (LMU), Wuppertal + DESY, GridKa, MPP

➤ Suggestion for spokespersons:

Günter Quast (CMS) and Christian Zeitnitz (ATLAS, deputy)

→ many decades of great expertise, long-lasting experience and good and fruitful cooperation



comparison not my idea
but mentioned by one of the
suggested new spokespersons

Waldorf and Statler my favourites
in the Muppet Show

Christian and Günter even more
my favourites as new spokespersons