

Figure 1 Block diagram of a power unit on-chip readout.

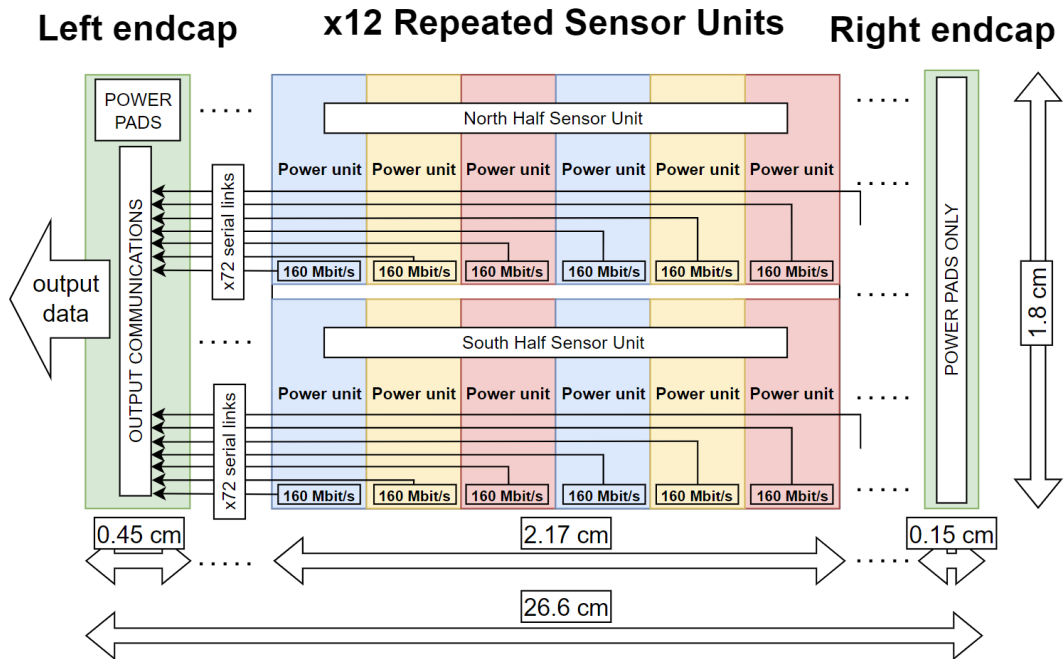

Figure 2 Floor plan of the ITS3 stitching monolithic sensor.