



TOTEM / PPS XRP Interlock Tests



MPP Meeting

24 March 2023

Mario Deile



Test Summary



Screenshots from MPP checklist:

<https://checklist.cern.ch/machine/13/node/1003699>

	All P5 Roman pots
MPP/TOTEM - 01 - Injection permit removal	tested for each pot
MPP/TOTEM - 02 - User permit removal	tested for each pot and both sets of inner limits (old and IPL)
MPP/TOTEM 03 - LVDT bypass	

DEILE 2023-03-08 16:20:47

Test ok. See collimation logbook:
<https://logbook.cern.ch/elogbook-server#/logbook?logbookId=1696&dateFrom=2023-03-08T07%3A00%3A00&dateTo=2023-03-09T07%3A00%3A00>

DEILE 2023-03-08 16:21:37

DEILE 2023-03-09 16:06:07

Test of IPL violations complete and ok. See collimation logbook:
<https://logbook.cern.ch/elogbook-server#/logbook?logbookId=1696&dateFrom=2023-03-08T07%3A00%3A00&dateTo=2023-03-09T07%3A00%3A00>
<https://logbook.cern.ch/elogbook-server#/logbook?logbookId=1696&dateFrom=2023-03-09T07%3A00%3A00&dateTo=2023-03-10T07%3A00%3A00>

DEILE 2023-03-09 18:18:07

DEILE 2023-03-09 18:18:59

Test of dump limit violations complete and ok. See collimation logbook:
<https://logbook.cern.ch/elogbook-server#/logbook?logbookId=1696&dateFrom=2023-03-09T07%3A00%3A00&dateTo=2023-03-10T07%3A00%3A00>

DEILE 2023-03-17 15:23:01

Bypass box successfully tested:
<https://logbook.cern.ch/elogbook-server#/logbook?logbookId=1696&dateFrom=2023-03-17T07%3A00%3A00&dateTo=2023-03-18T07%3A00%3A00>
 also reported here: test of Override key.

DEILE 2023-03-17 15:23:50

Beam mode and flags combinatorics test not done, as agreed (interlock logic card not touched). Last test: spring 2022.



Status



No anomalies observed.

XRP system ready for beam.



Reference Material



Movement System Architecture (strongly simplified)

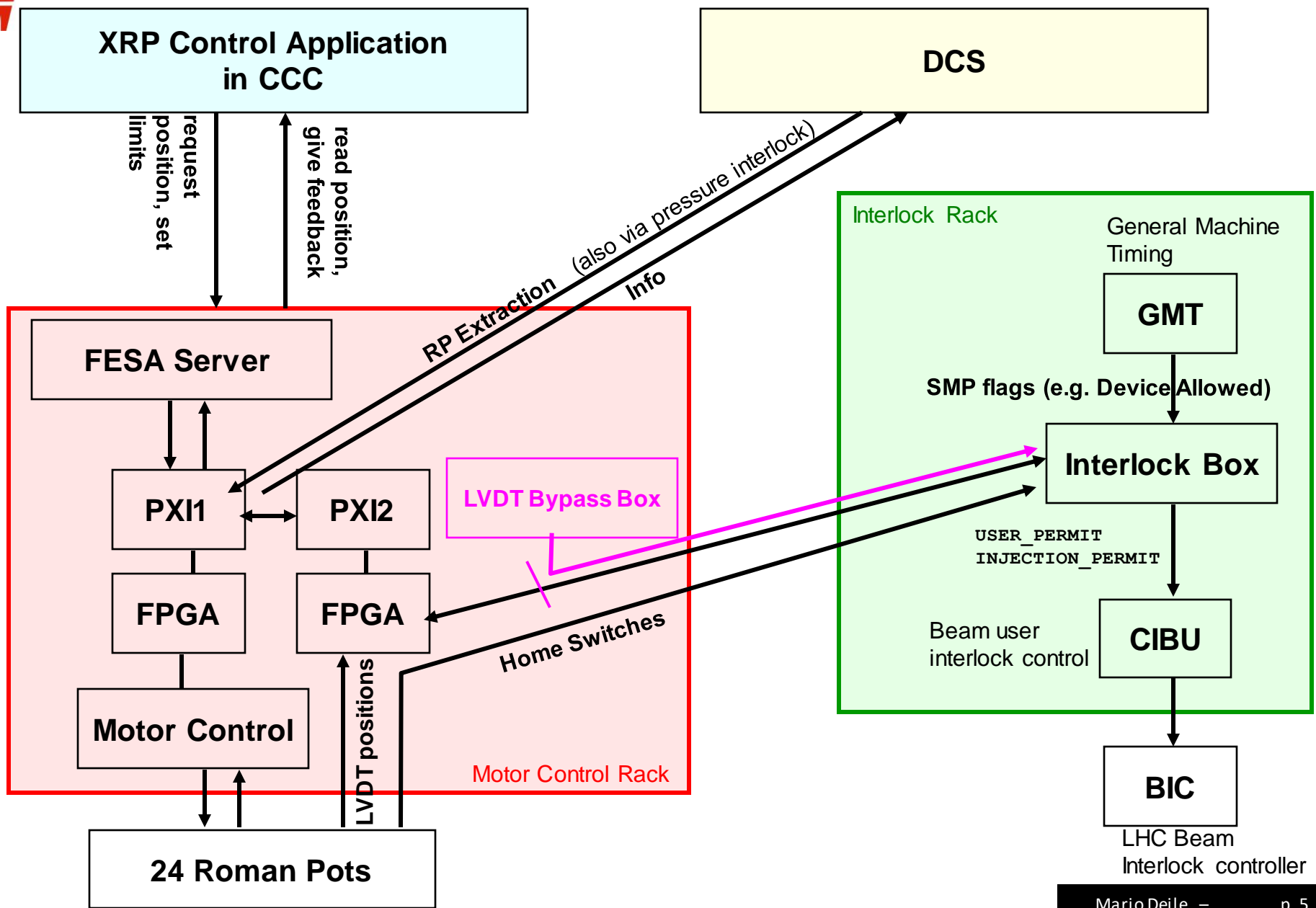



TOTEM-BIS Interlock Logic Since 2015

IN MOTOR CONTROL RACK

TOTEM INTERLOCK BOX

CMS S1E08

