Searching for new physics @ Large Hadron Collider: with precision & innovation

Tulika Bose

University of Wisconsin-Madison



WISCONSIN
UNIVERSITY OF WISCONSIN-MADISON

June 5, 2023



Tulika Bose

*Professor of Physics
University of Wisconsin-Madison
Deputy Program Manager USCMS Software &
Computing
tulika@hep.wisc.edu*

My research:

Standard Model measurements, searches for Beyond the Standard Model particles at the CMS Experiment Trigger and data-acquisition, Software & Computing

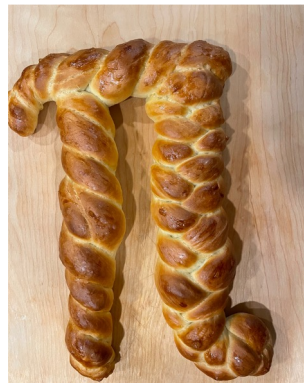

I enjoy:

Working on challenging tasks in a collaborative setting

Beyond research, I am particularly interested in:

Outreach, science communication and improving diversity and inclusion

I've got my eyes on:

Learning to cook gourmet meals, playing the piano, spending more time with my family!



The smallest pieces of matter...

- Particle physics is the study of smallest known building blocks of the physical universe -- and the interactions between them.
- The focus is on single particles or small groups of particles, not the billions of atoms or molecules making up an entire planet or star.

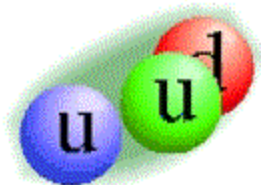

Relativistic Collisions

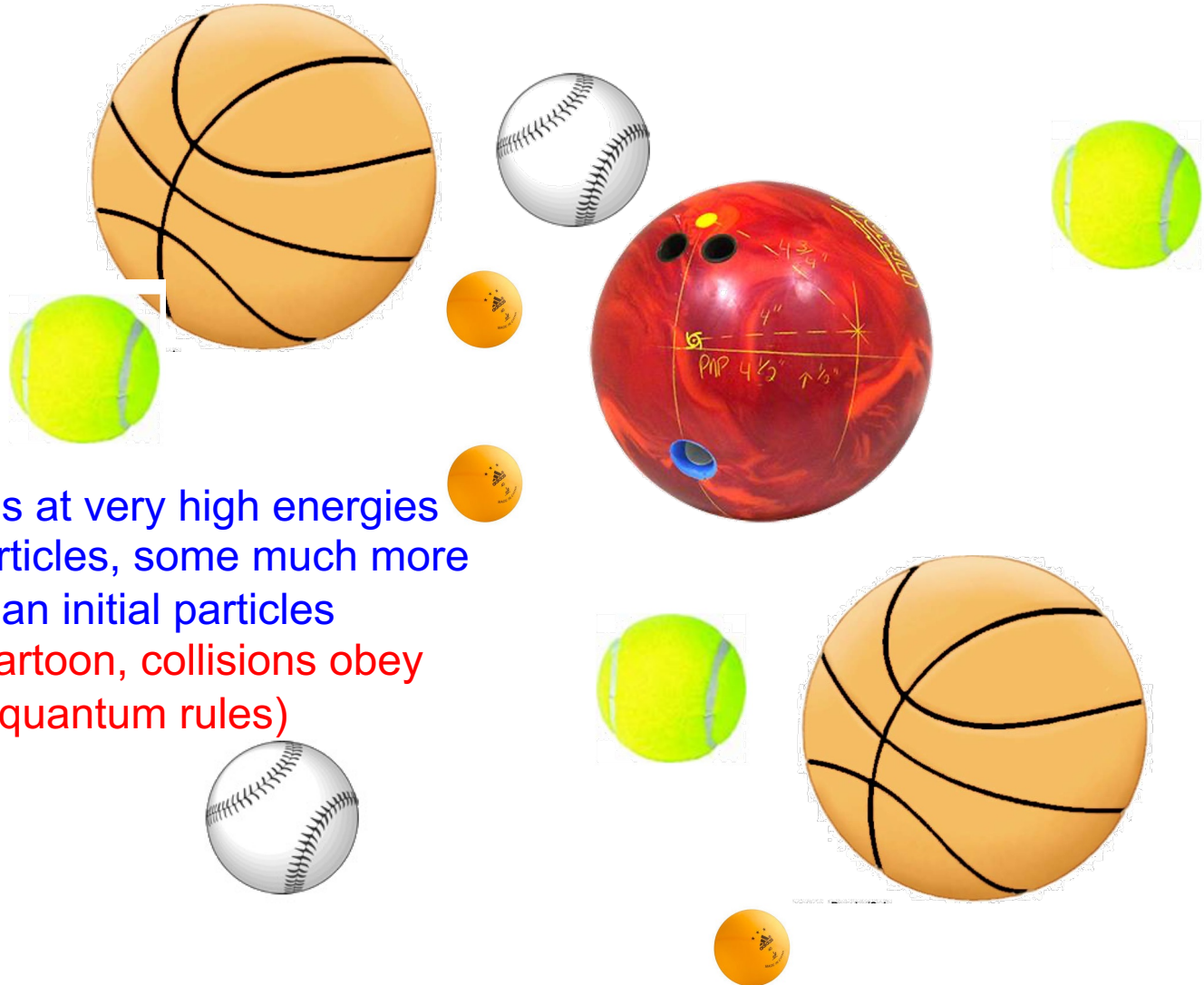

Particle collisions at very high energies produce many particles, some much more massive than initial particles (unlike in this cartoon, collisions obey specific quantum rules)

Elementary and composite particles studied in great detail over the past 50 years

“Standard Model” of Particles and Forces

- Incorporates:
 - Electroweak theory by Glashow, Weinberg and Salam
 - Quantum Chromo Dynamics – theory of strong interactions

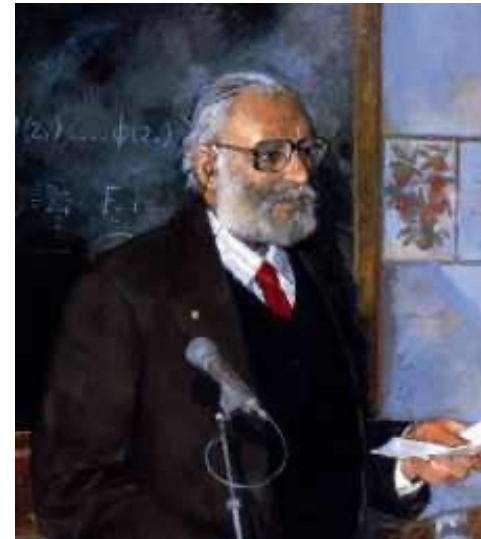

“Standard Model” of Particles and Forces

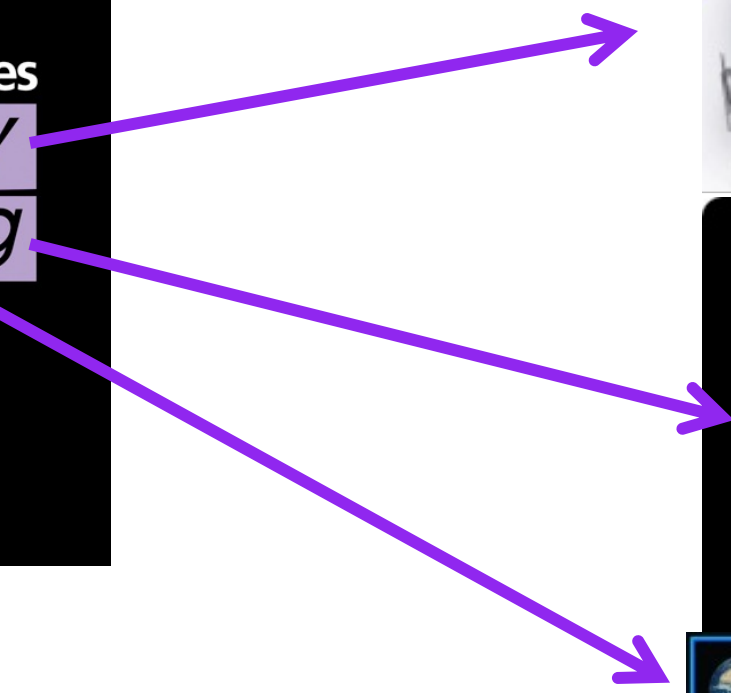
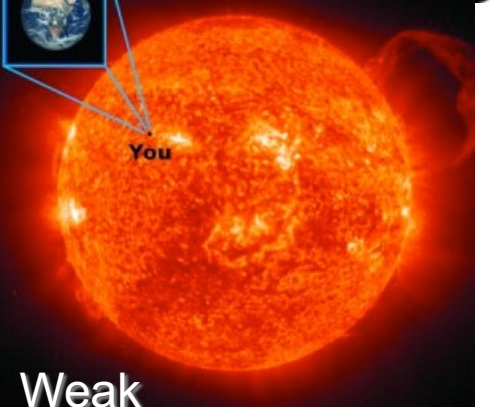
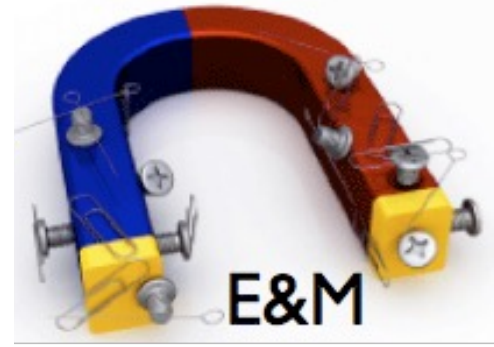
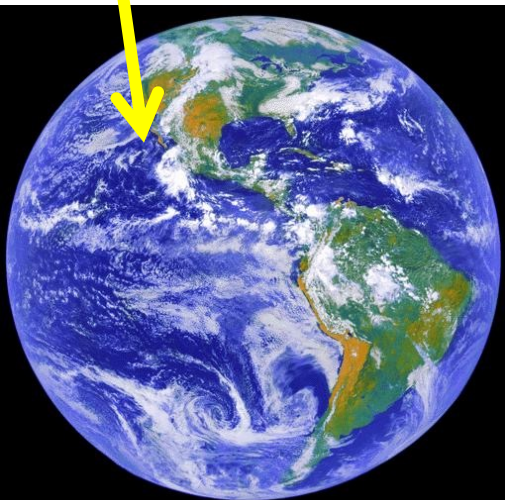
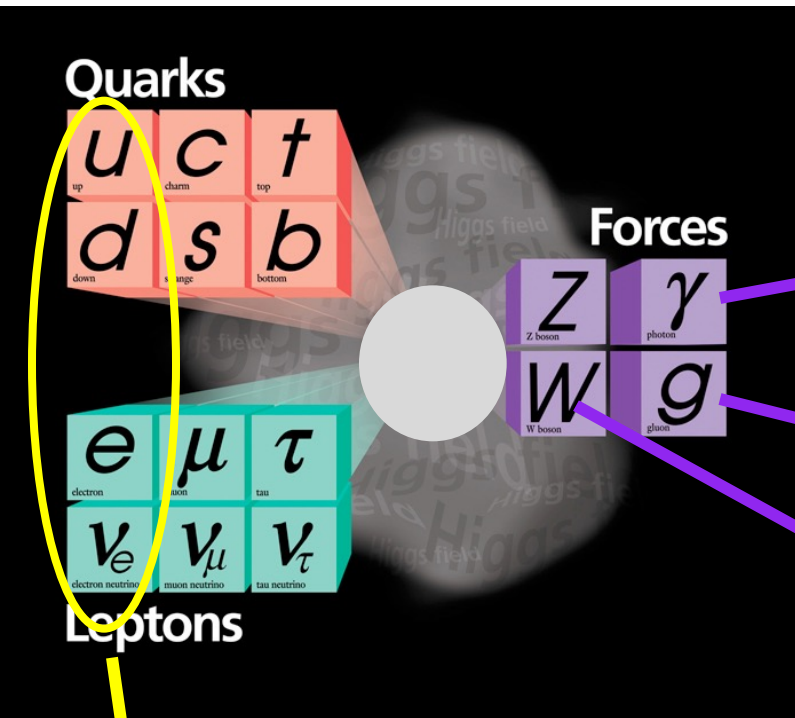

Fermions and Bosons

Fermions		Bosons	
Leptons and Quarks	Spin = $\frac{1}{2}$	Spin = 1*	Force Carrier Particles
Baryons (qqq)	Spin = $\frac{1}{2}$ $\frac{3}{2}, \frac{5}{2}, \dots$	Spin = 0, 1, 2...	Mesons (q \bar{q})

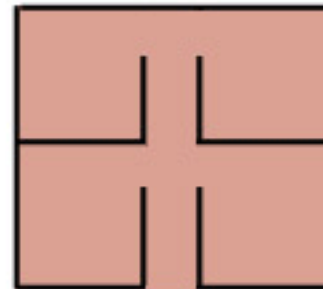
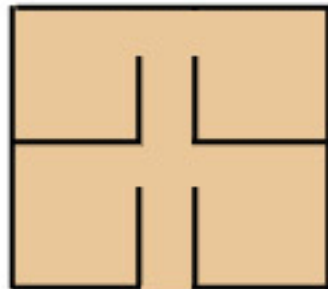

“Standard Model” of Particles and Forces

Quarks

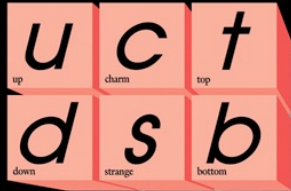

Forces

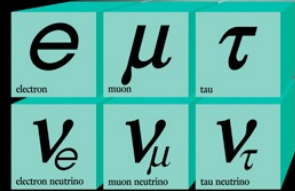
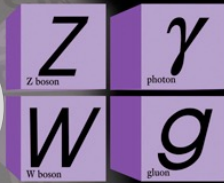

Leptons

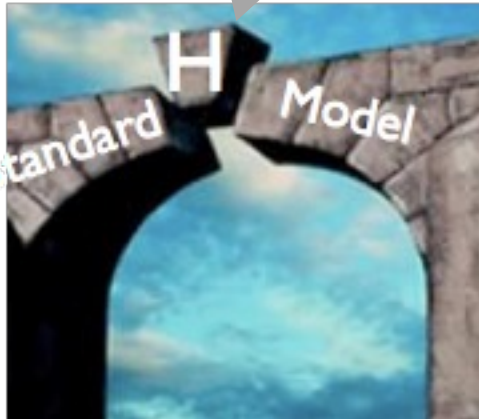

Works beautifully for massless quanta

$$M_W = 80 \text{ GeV}, M_Z = 91 \text{ GeV}, m_g, m_\gamma = 0$$

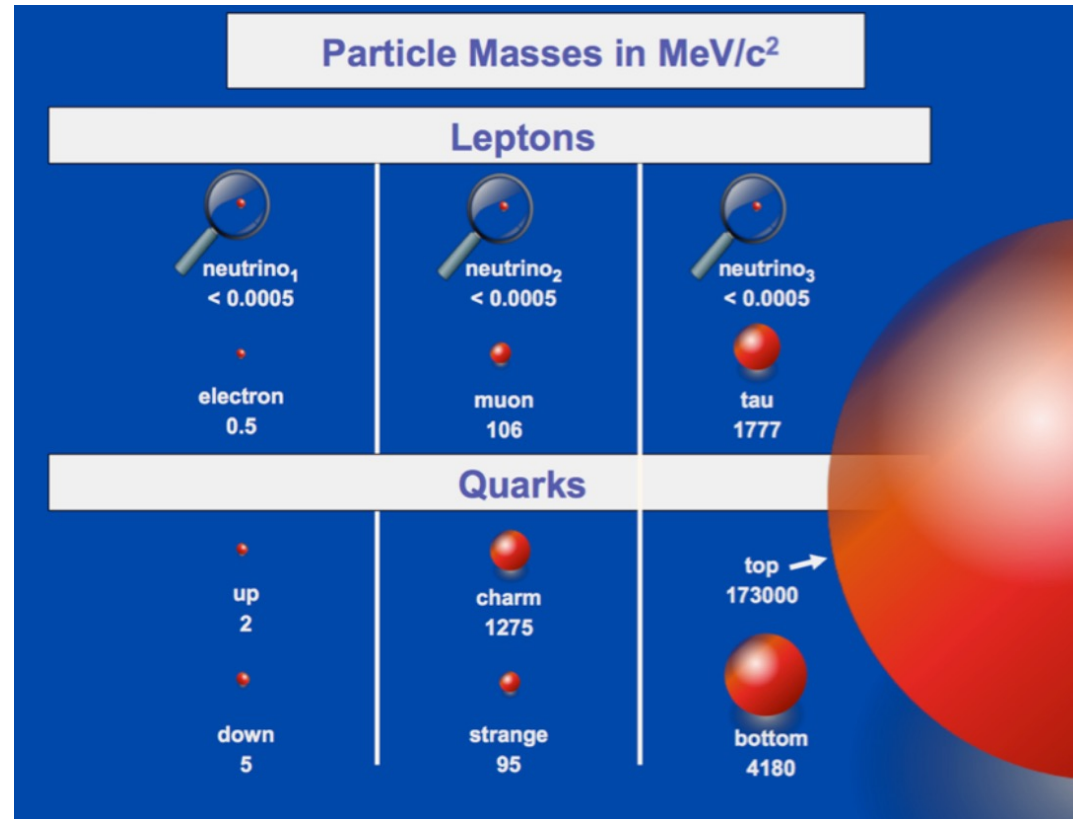

Needs Higgs field for providing mass to the elementary particles

“Standard Model” of Particles and Forces

Quarks

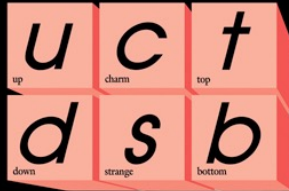

Forces

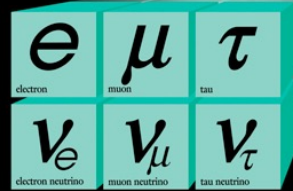

Leptons

The Standard Model:
Some assembly required.
Gravity not included

Works beautifully for massless quanta

$$M_W = 80 \text{ GeV}, M_Z = 91 \text{ GeV}, m_g, m_\gamma = 0$$

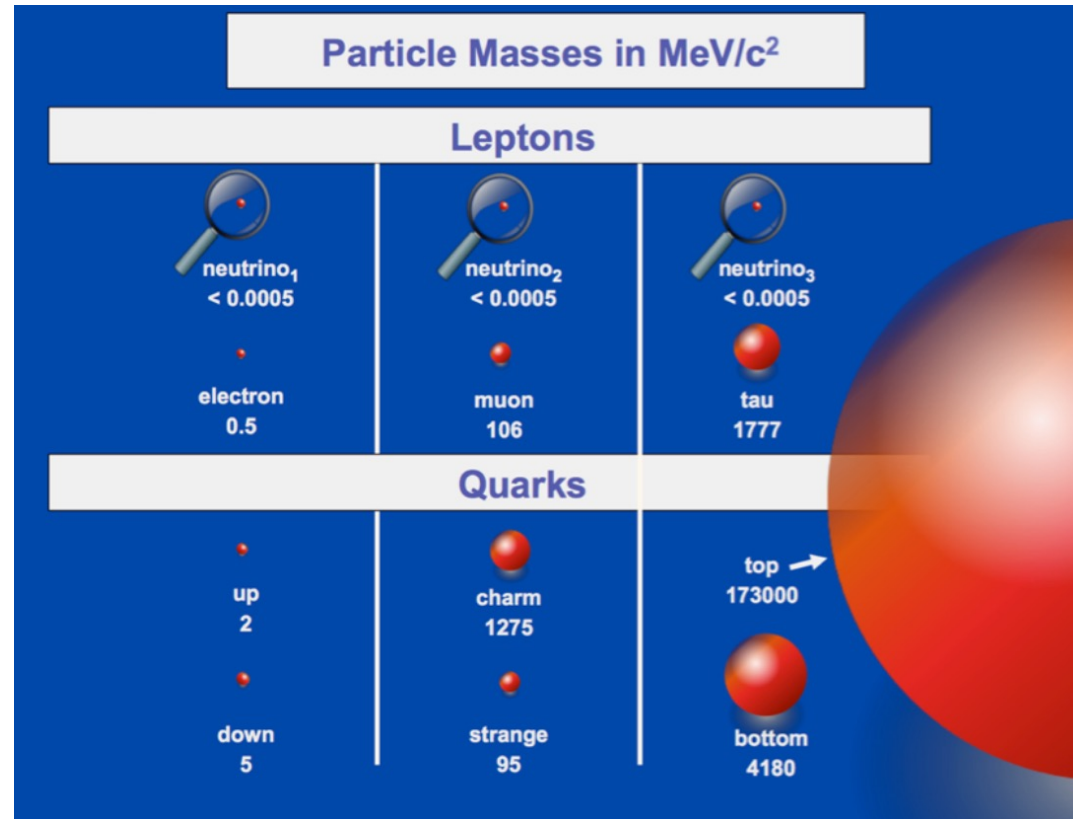

Needs Higgs field for providing mass to the elementary particles

Interactions with Higgs Field

- Which of these falls slower safely?
 - An unopened parachute
 - Fully opened parachute

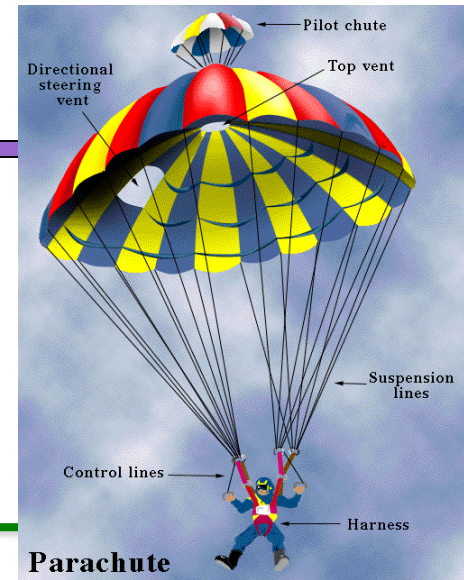

The more interaction with the medium (air) the lower the speed of the drop

Higgs field permeates all space, particles interact with differing strengths with the higgs field. The higher the interaction the larger the particle's mass.



The Guralnik-Hagen-Kibble-Higgs- Englert-Brout field...

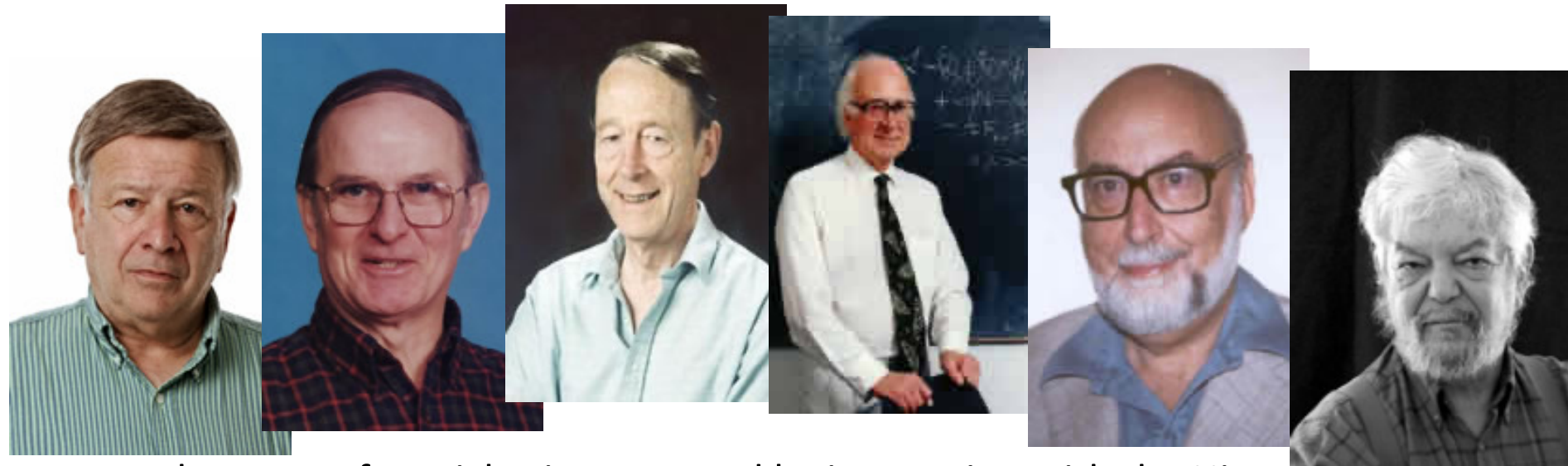

- The mass of particles is generated by interaction with the Higgs field. This was predicted independently by three groups and published in 1964 in the same volume of Physical Review Letters.
 - All three papers were written from different perspectives, and each made a distinct contribution
- Physical Review Letters volume 13 (1964):
 - **Guralnik, Hagen, Kibble**, "Global Conservation Laws and Massless Particles"
 - **Higgs**, "Broken Symmetries and the Masses of Gauge Bosons"
 - **Englert, Brout**, "Broken Symmetry and the Mass of Gauge Vector Mesons"

THEORY: The “Higgs” Field

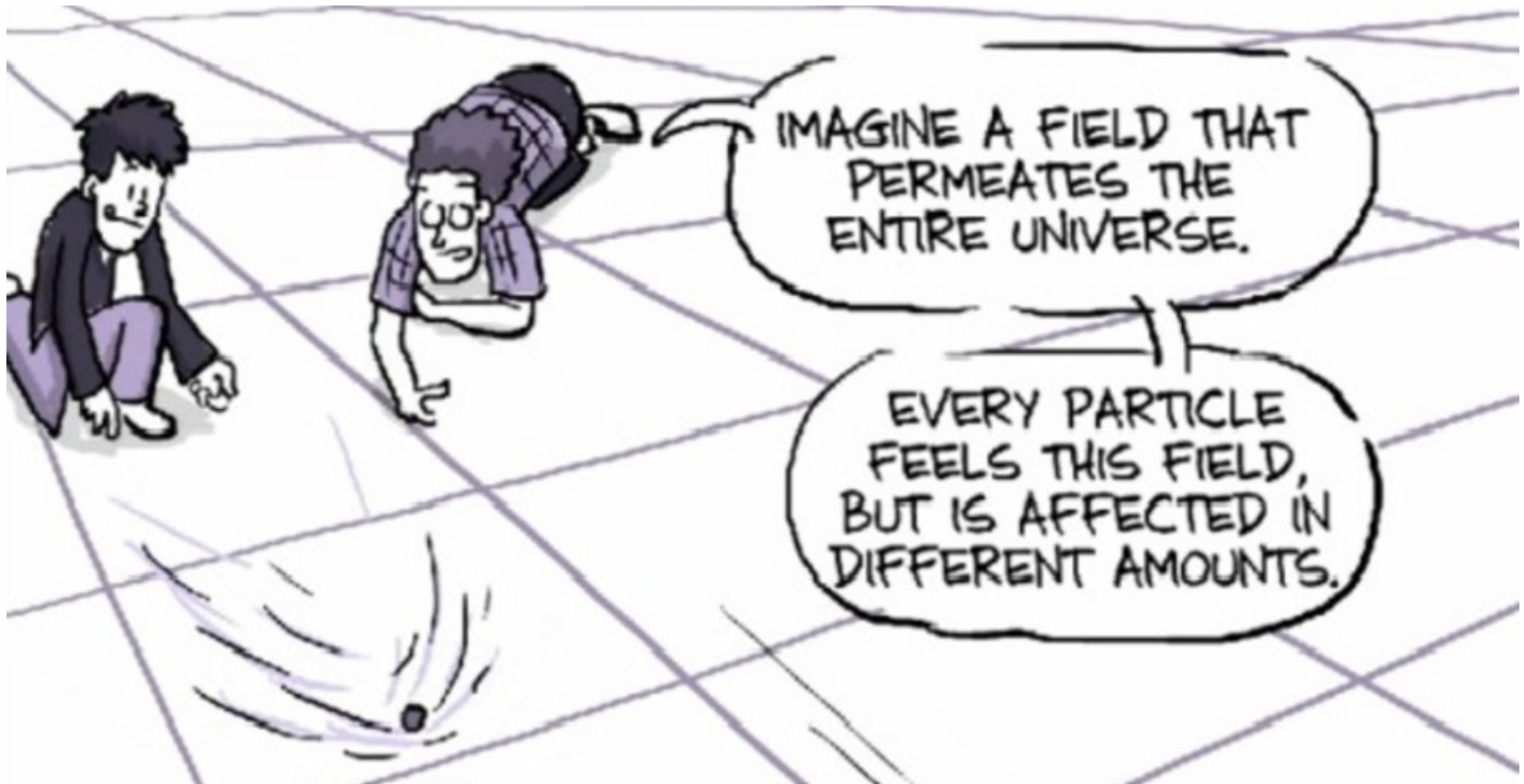

The more a particle interacts with this *invisible* field, the more mass it gets.

But if this field is **invisible**,
how can we **PROVE** it exists?

The theory predicts that the field has an associated particle:



The Higgs Boson!

We can try to create the Higgs boson in our experiment!

Challenge: the theory does not predict its mass

Other open questions

Why is there a large mass hierarchy in the fermion sector ?

Why are there exactly 3 generations ?

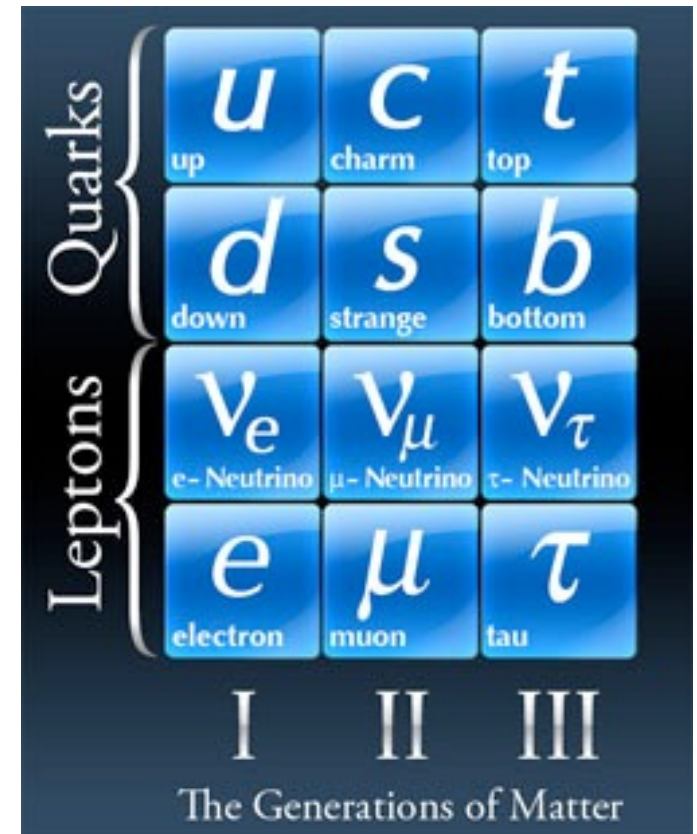
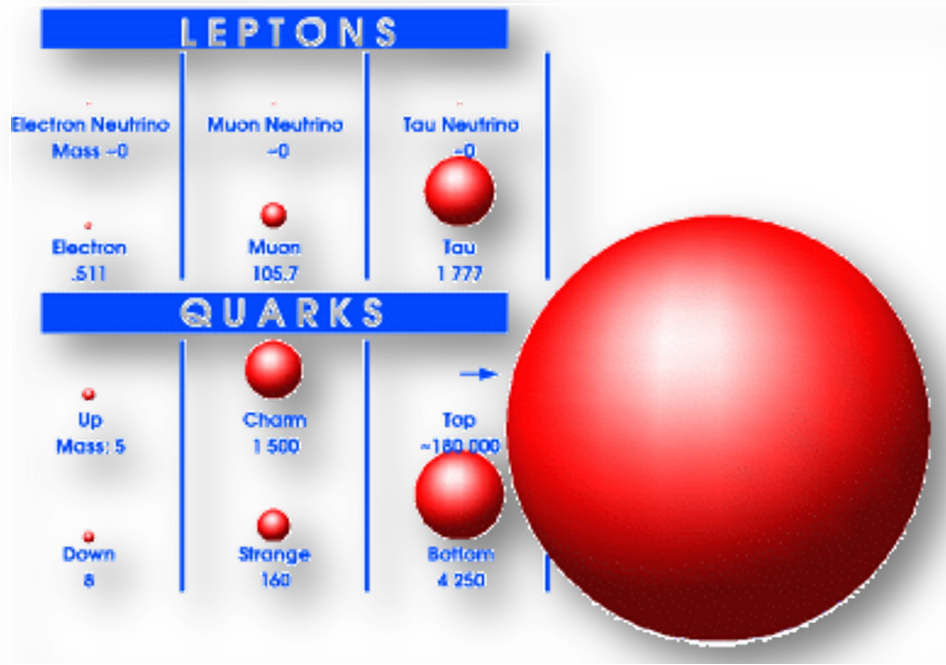

What remains to be answered ?

How can we explain the matter anti-antimatter asymmetry ?

Anti-Tom Hanks



Would look
very much like

Tom Hanks



What remains to be answered ?

How can we explain the matter anti-matter asymmetry ?

But were they to meet...

**We are still here
and no naturally occurring antimatter is in sight!**



What remains to be answered ?

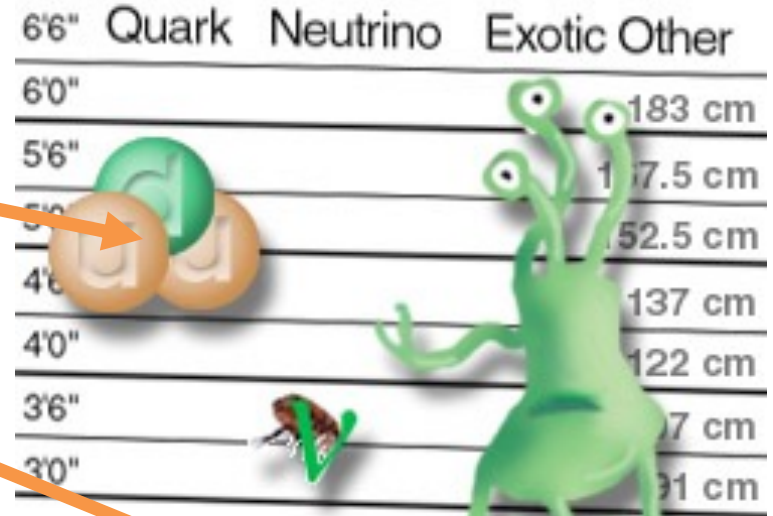
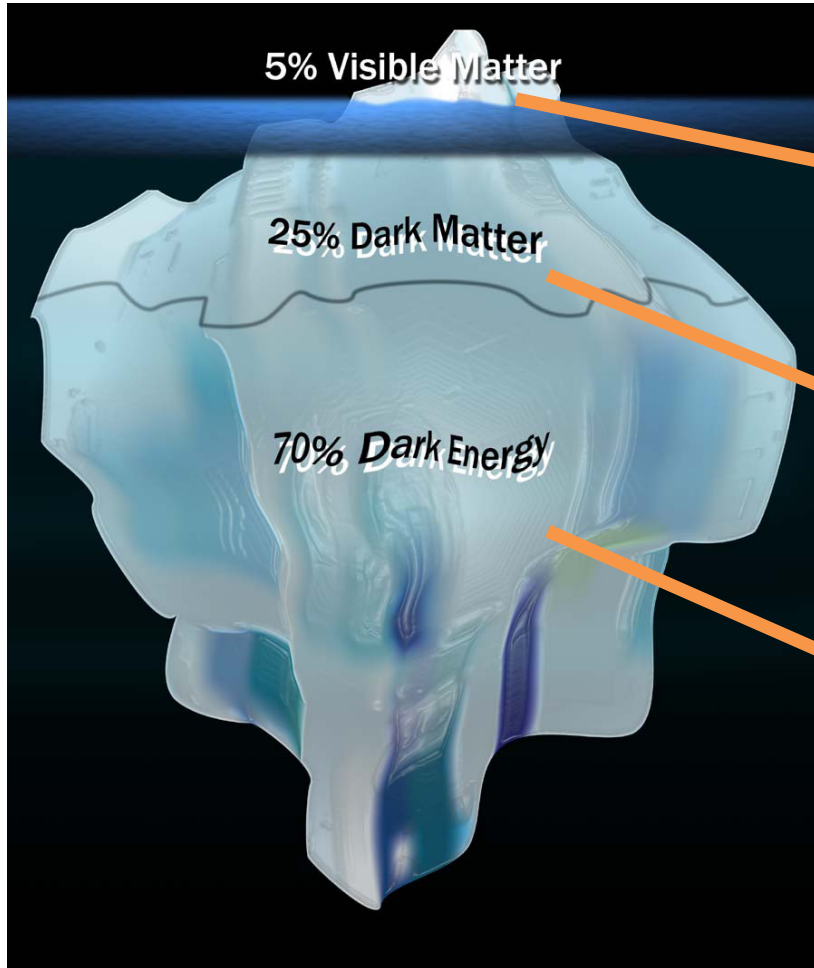

?

"All right... which of you punks is responsible for dark matter?"

What remains to be answered ?

What is dark matter ?

Where is gravity ????

Are new particles the solution ?

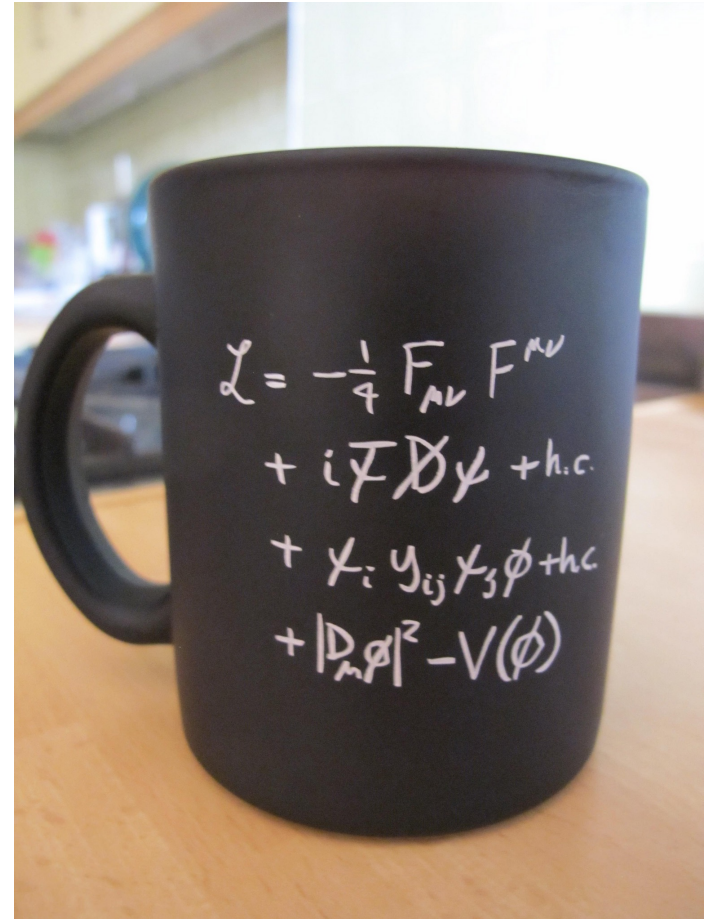

Does the Higgs interact with dark matter ?

Potential Answers

SUPERSYMMETRY

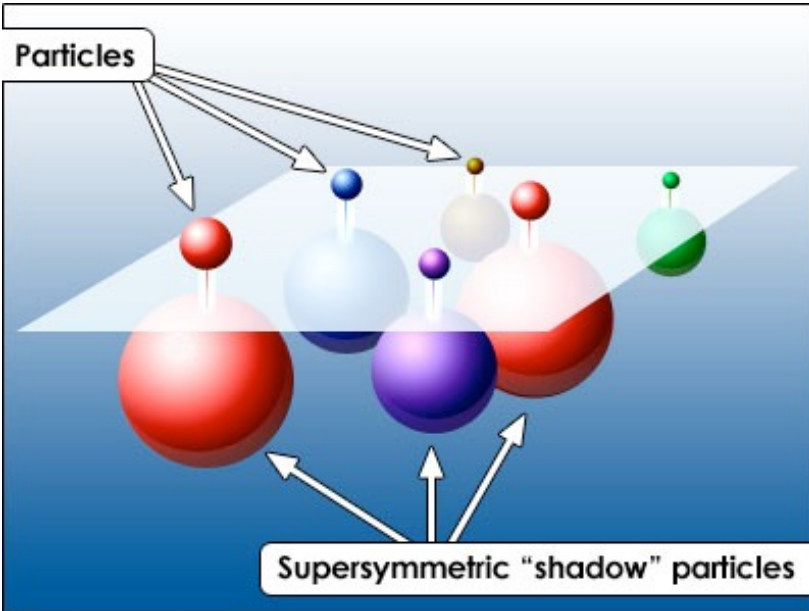

EXTRA DIMENSIONS

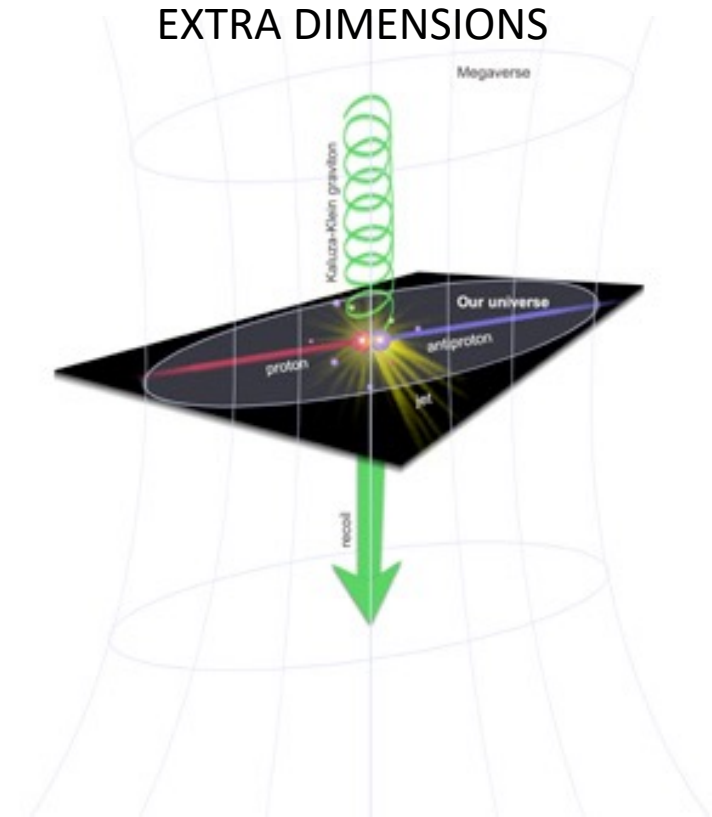

And many more...

Hunting for the Exotic

What new physics are we looking for ?



Start by asking these questions in the right way

Look more closely
Look in new places

More Precision, new techniques
Higher Energy, new measurements

The Energy Frontier....

The Large Hadron Collider...

Run 1:

- a) proton beams with 3.5 TeV (trillion electron volts) energy for a total collision energy of 7 TeV (2010-2011)
- b) proton beams with 4 TeV energy for a total collision energy of 8 TeV (2012)



Run 2 (2015-2018) with proton beams at 6.5 TeV energy for a total collision energy of 13 TeV

Run 3 started in 2022. Dedicated heavy-ion collision runs as well

One of the fastest racetracks on the planet...



Several thousand billion protons travelling at 99.9999991% of the speed of light will travel round the 16.8 mile ring over 11000 times a second!

(that's 670,626,025 mph)

- About 300 ft under ground
- 8.4 T dipole magnets (1232 magnets)
- Cooled to 1.9K with 96 tons of liquid helium
- Energy of beam = 362 MJ

15 kg of chocolate

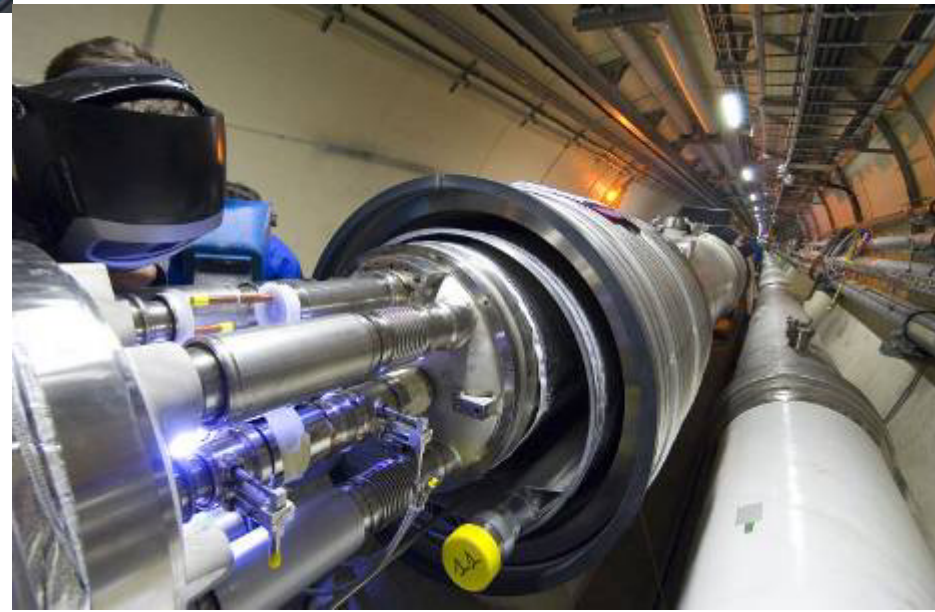

Where will occur some of the hottest reactions in our galaxy...

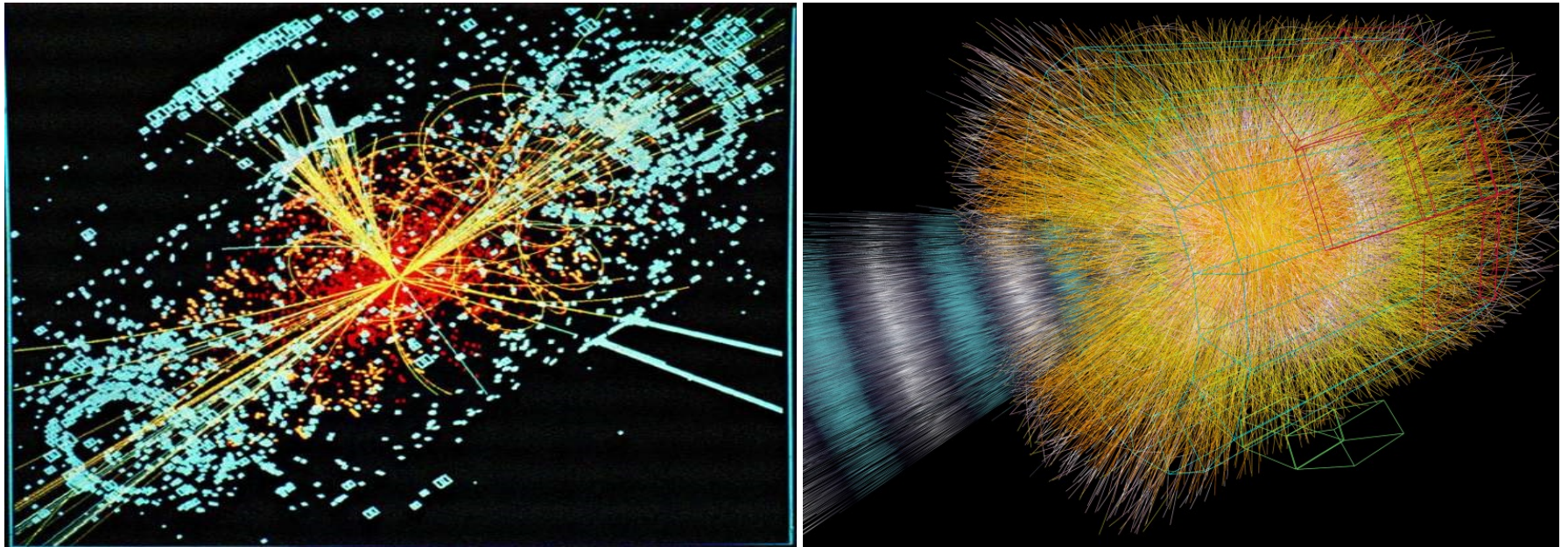

Violent collisions corresponding to temperatures a billion times higher than the core of the sun will be produced.

That is roughly 160,000,000,000,000,000 C

to be watched by some of the most complex “eyes” we’ve ever built,



Quarks. Neutrinos. Mesons. All those damn particles you can't see. That's what drove me to drink. But now I can see them.

Particle Detectors

allow us to
“see” particles

to be watched by some of the most complex “eyes” we’ve ever built,

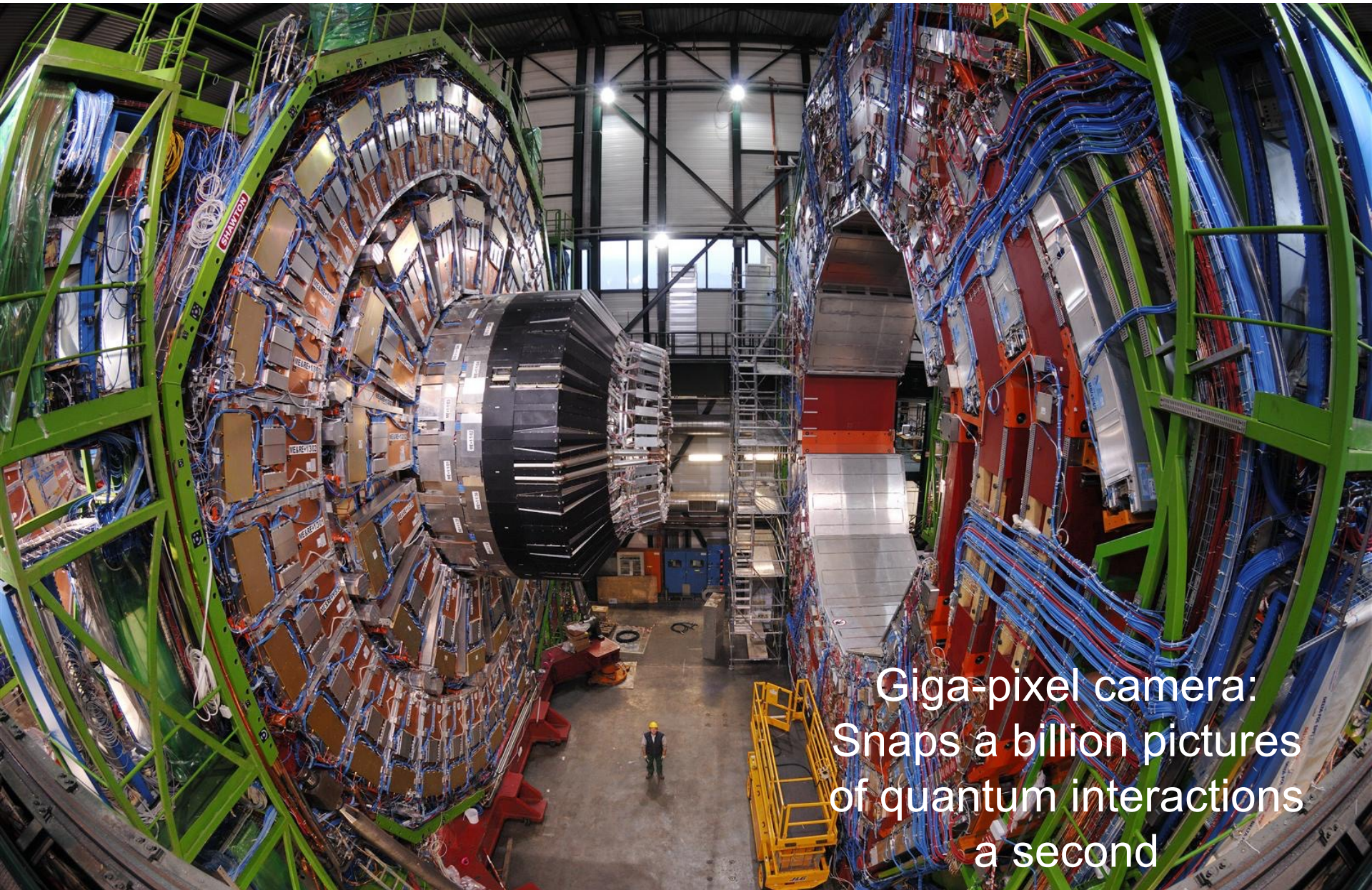

Giga-pixel camera:
Snaps a billion pictures
of quantum interactions
a second

ALICE

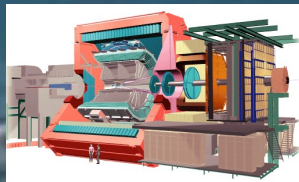

CMS

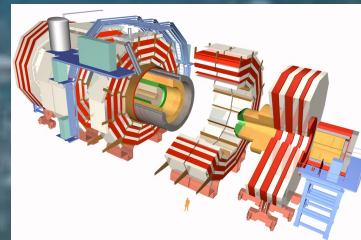

ATLAS

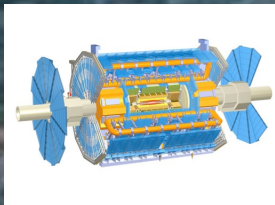

LHCb

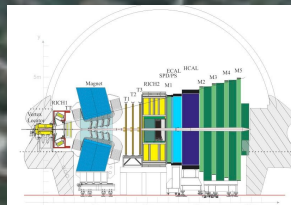

The CMS detector

More in Steve Nahn's talk today

- Took ~2000 scientists and engineers more than 20 years to design and build
- Is about 15 metres wide and 21.5 metres long
- Weighs twice as much as the Eiffel Tower – about 14000t
- (~40 large airplanes)

CMS DETECTOR

Total weight : 14,000 tonnes
Overall diameter : 15.0 m
Overall length : 28.7 m
Magnetic field : 3.8 T

STEEL RETURN YOKE
12,500 tonnes

SILICON TRACKERS

Pixel ($100 \times 150 \mu\text{m}$) ~16m² ~66M channels
Microstrips ($80 \times 180 \mu\text{m}$) ~200m² ~9.6M channels

SUPERCONDUCTING SOLENOID
Niobium titanium coil carrying ~18,000A

MUON CHAMBERS

Barrel: 250 Drift Tube, 480 Resistive Plate Chambers
Endcaps: 468 Cathode Strip, 432 Resistive Plate Chambers

PRESHOWER

Silicon strips ~16m² ~137,000 channels

FORWARD CALORIMETER
Steel + Quartz fibres ~2,000 Channels

CRYSTAL
ELECTROMAGNETIC
CALORIMETER (ECAL)
~76,000 scintillating PbWO₄ crystals

HADRON CALORIMETER (HCAL)
Brass + Plastic scintillator ~7,000 channels

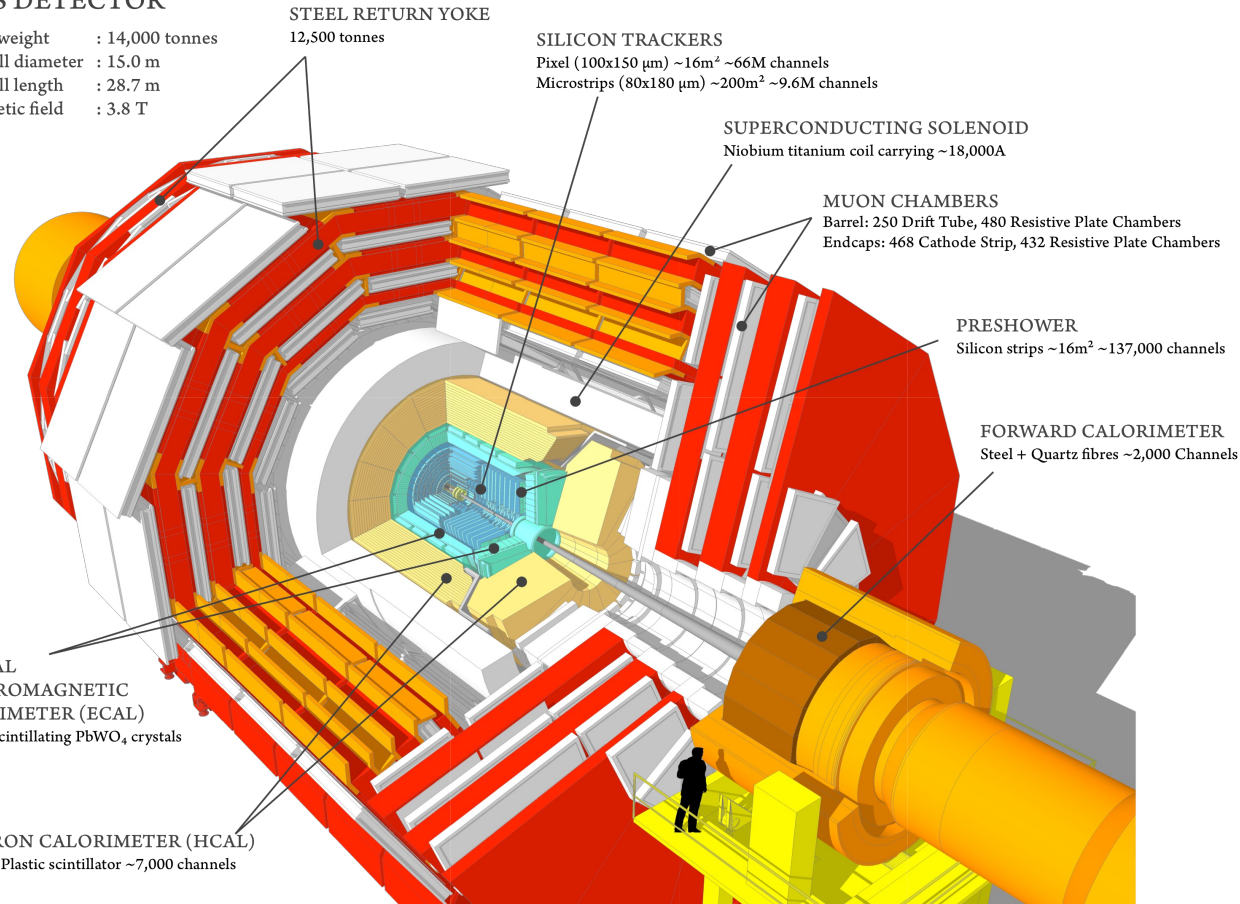

What do we observe with CMS?

- Photons
 - Light quanta
- Electrons
 - Lightest electrically charged lepton
- Muons
 - Heavier cousin of electron (interacts minimally)
- Charged hadrons (π , K , protons)
 - Composite charged particles made of quarks
- Neutral hadrons (neutrons, K_L)
 - Composite neutral particles made of quarks

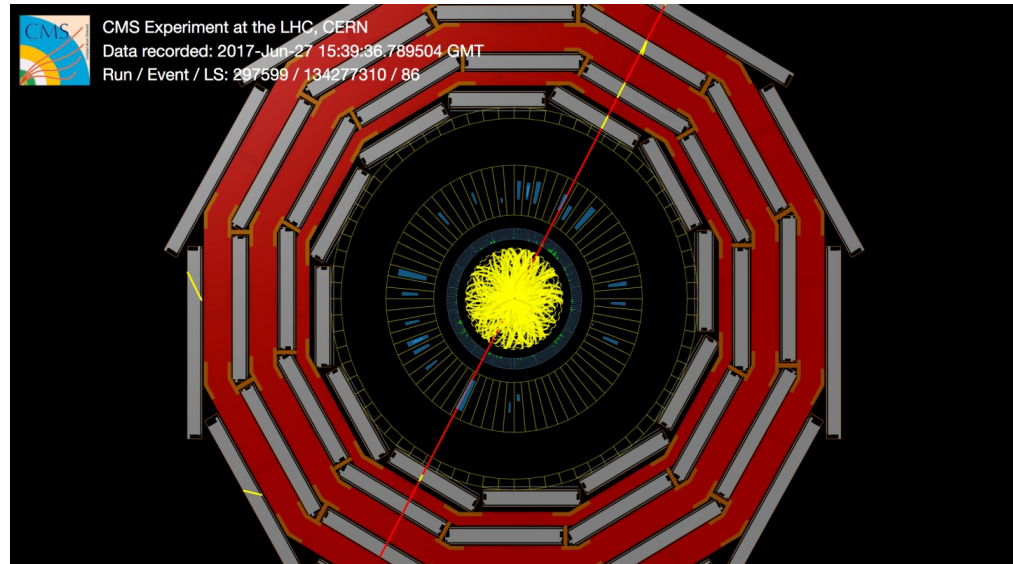

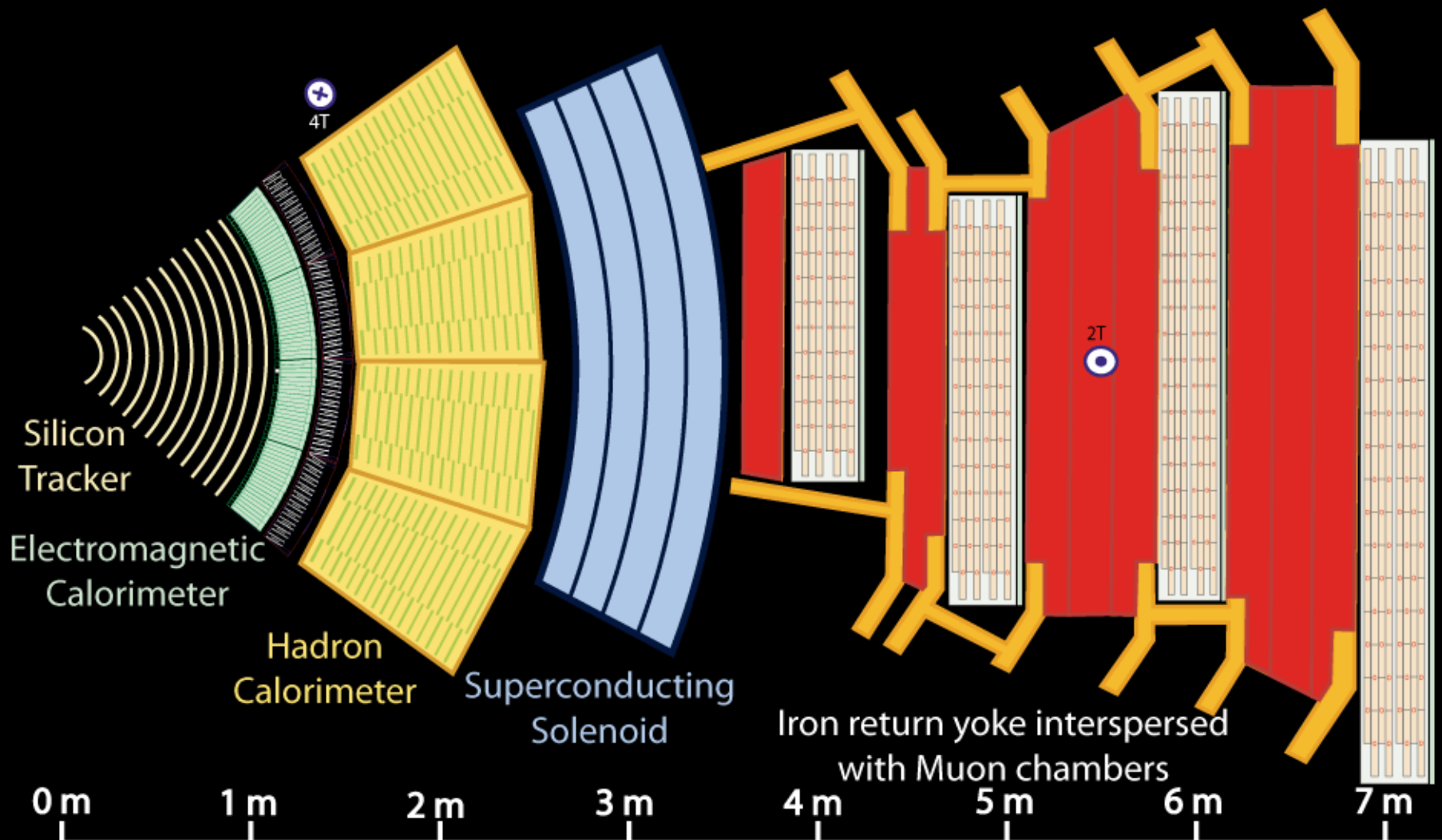

Key:

- Muon
- Electron
- Charged Hadron (e.g. Pion)
- - - Neutral Hadron (e.g. Neutron)
- - - Photon

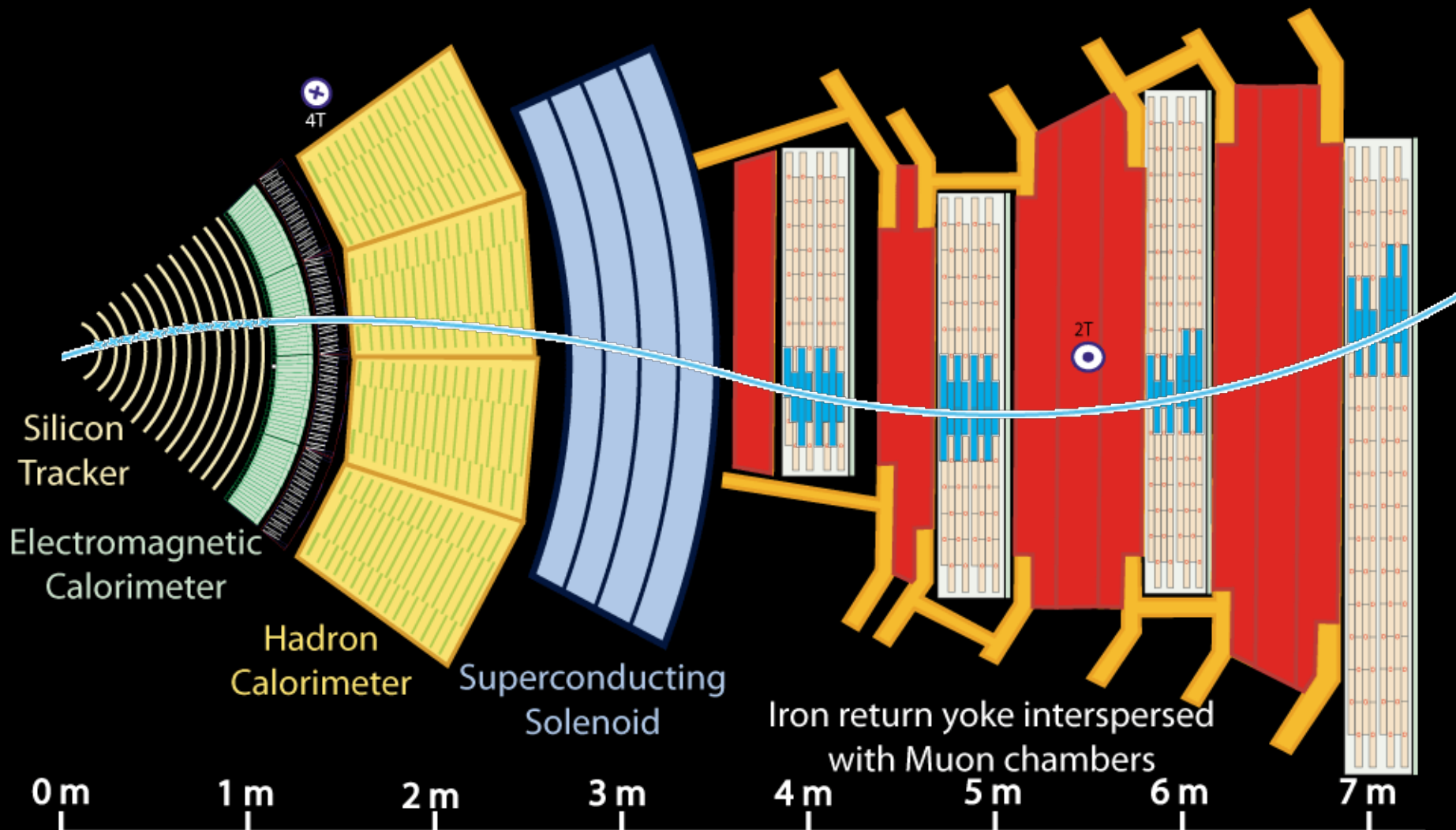

Key:

- Muon
- Electron
- Charged Hadron (e.g. Pion)
- - - Neutral Hadron (e.g. Neutron)
- - - Photon

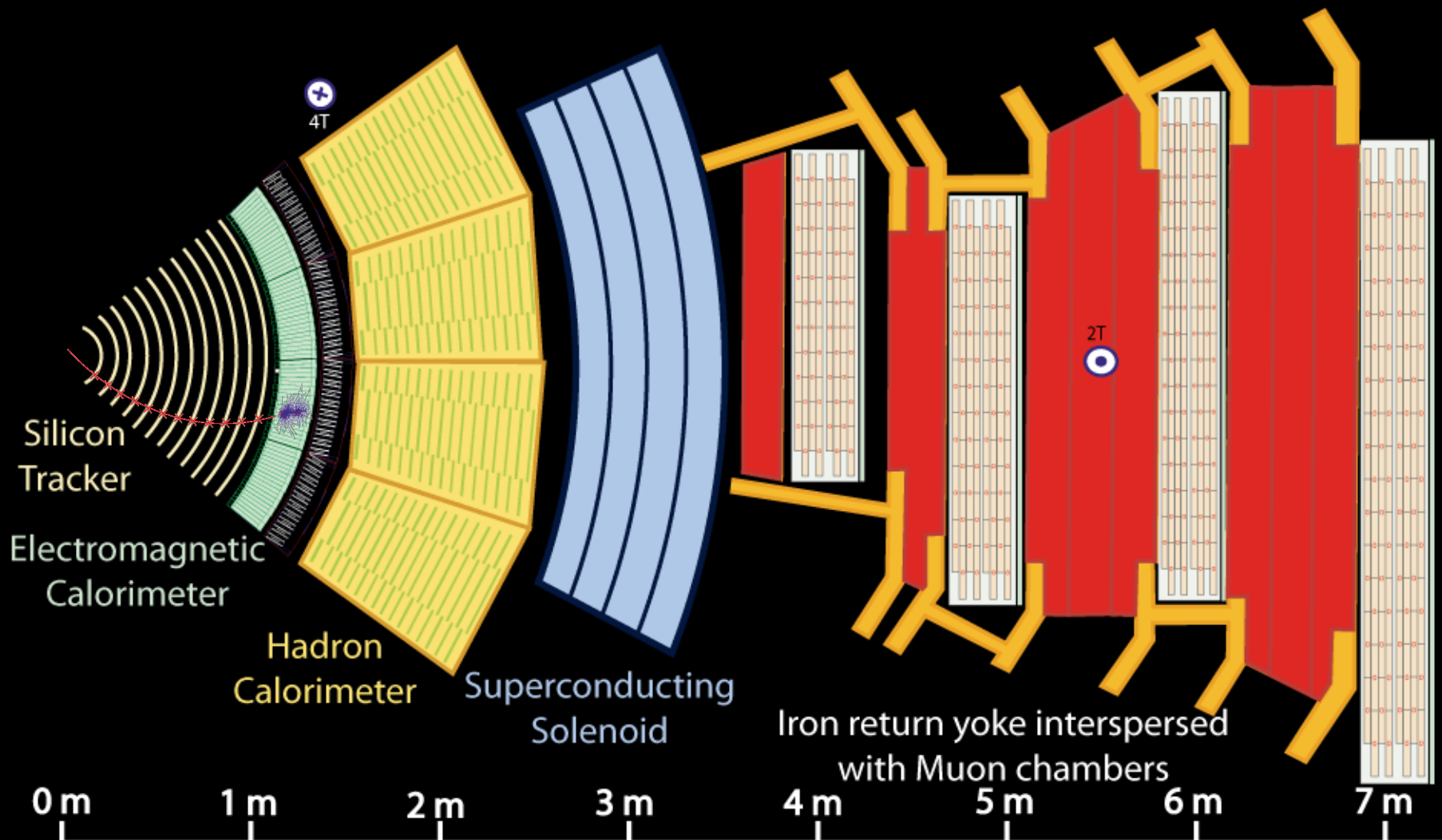

Key:

- Muon
- Electron
- Charged Hadron (e.g. Pion)
- - - Neutral Hadron (e.g. Neutron)
- - - Photon

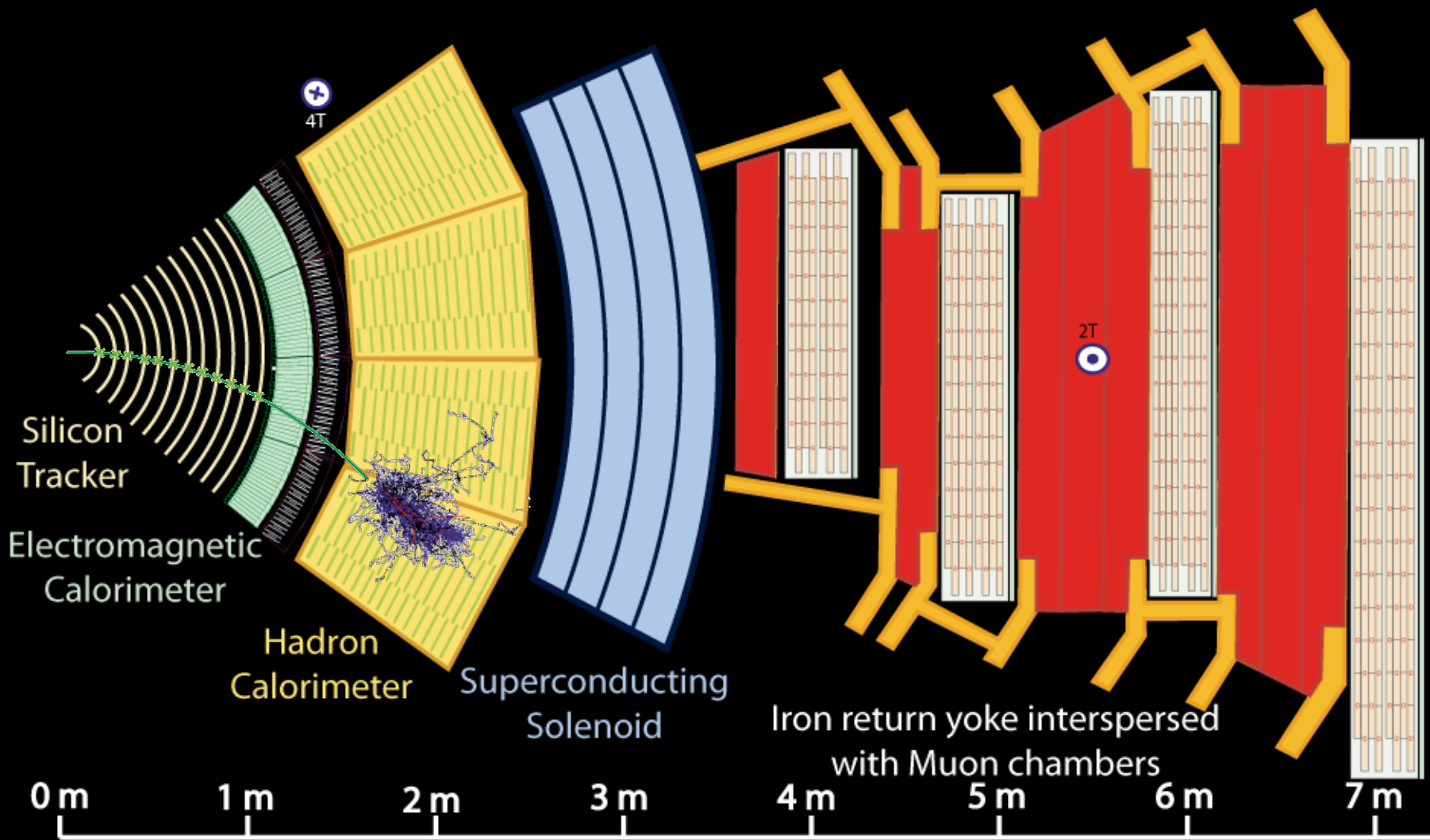

Key:

- Muon
- Electron
- Charged Hadron (e.g. Pion)
- - - Neutral Hadron (e.g. Neutron)
- - - Photon

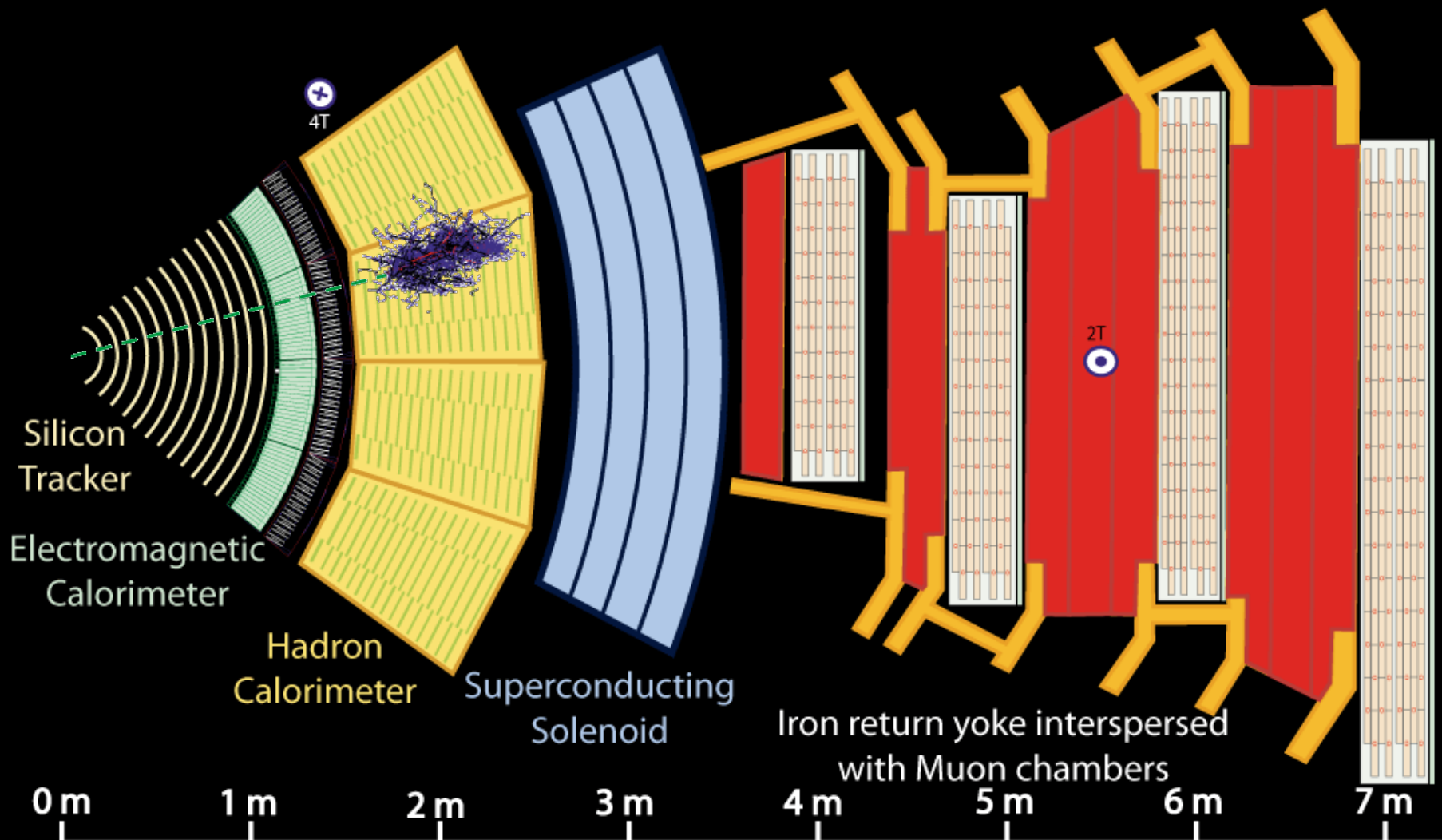

Key:

— Muon

— Electron

— Charged Hadron (e.g. Pion)

- - - Neutral Hadron (e.g. Neutron)

- - - Photon

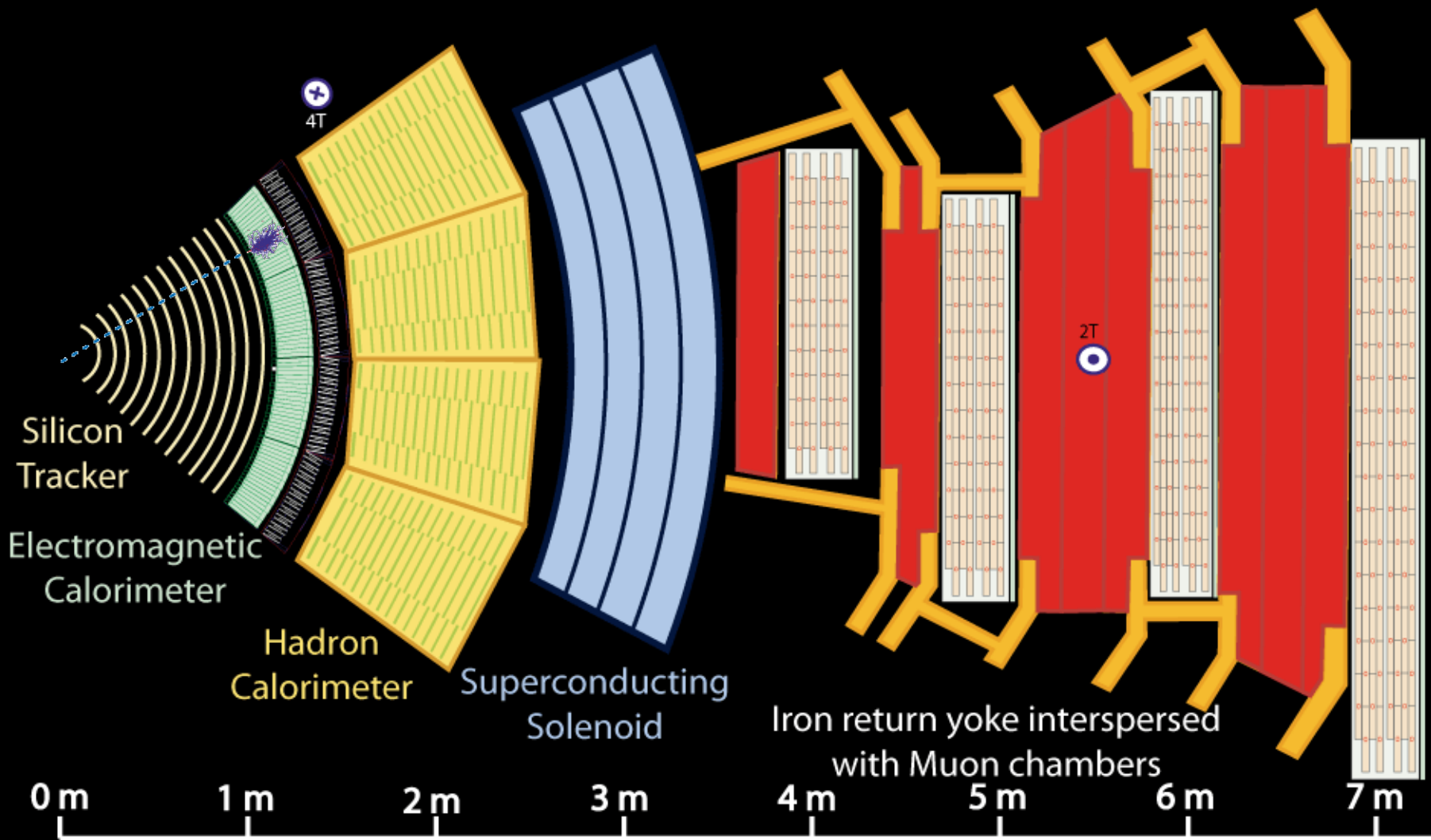

Key:

- Muon
- Electron
- Charged Hadron (e.g. Pion)
- - - Neutral Hadron (e.g. Neutron)
- - - Photon

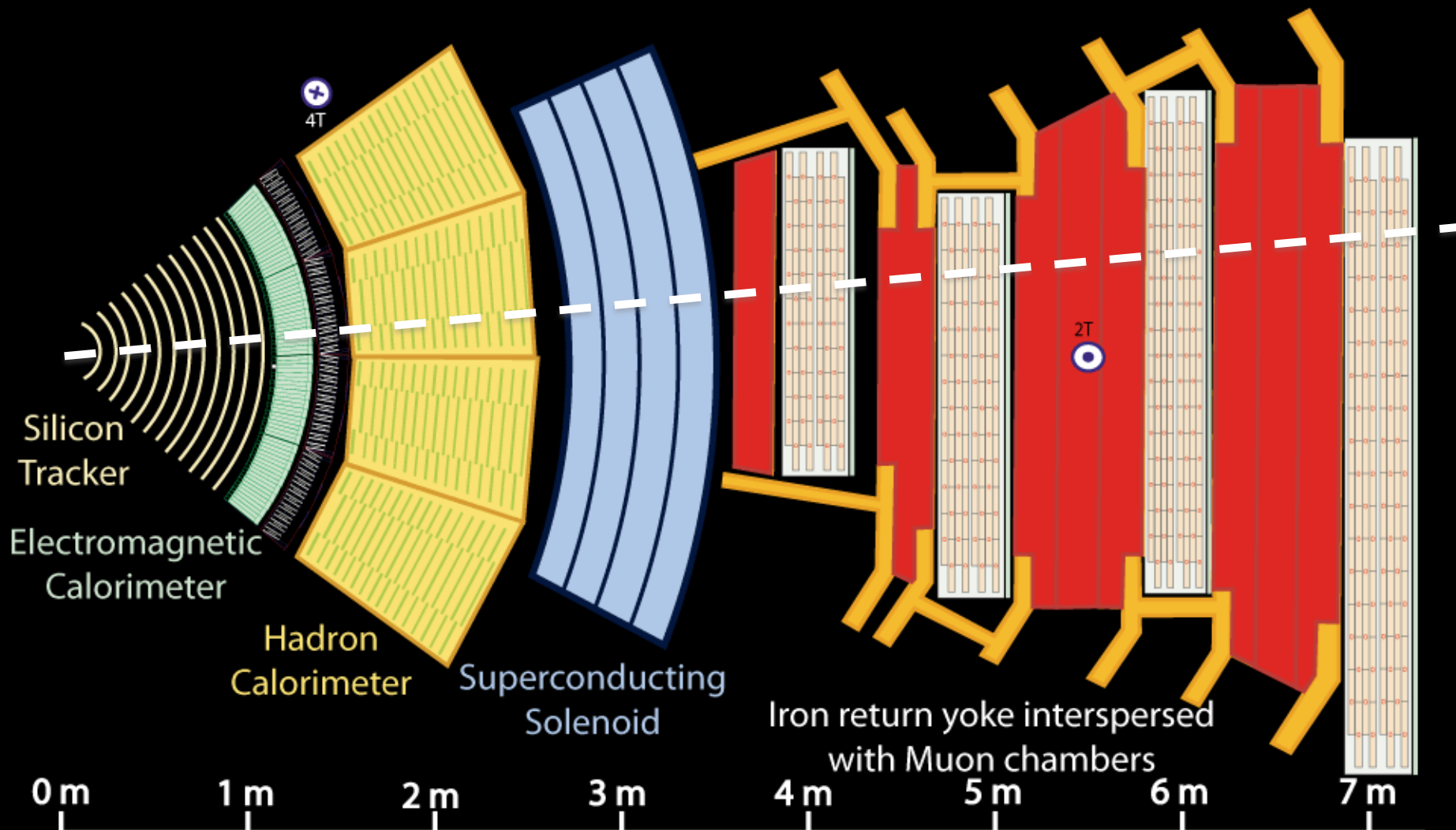

0 m 1 m 2 m 3 m 4 m 5 m 6 m 7 m

Key:

- Muon
- Electron
- Charged Hadron (e.g. Pion)
- - - Neutral Hadron (e.g. Neutron)
- - - Photon
- - - - Neutrino

The Challenge at the LHC

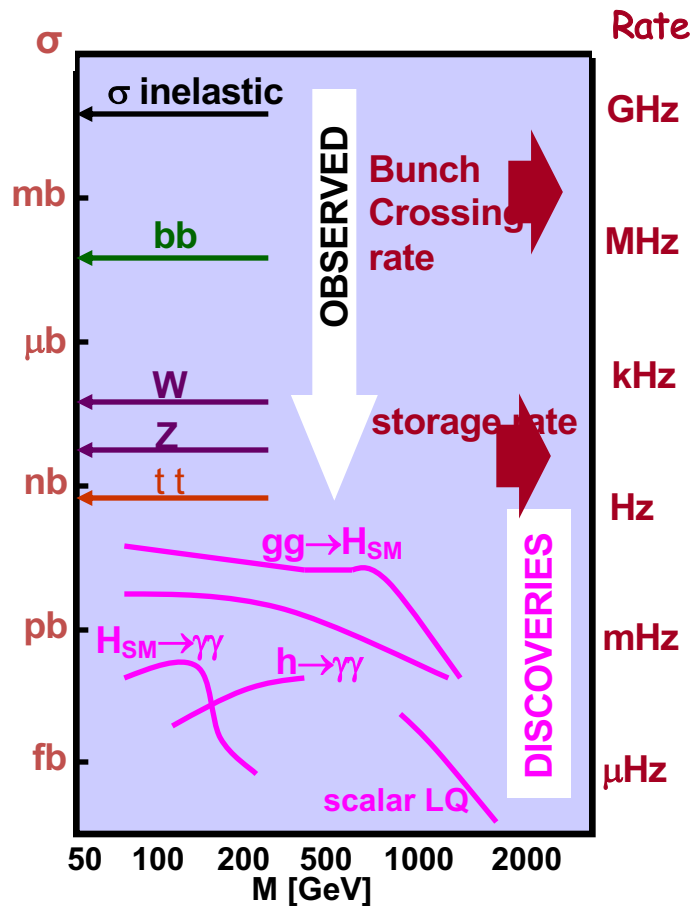

LHC: $\sim 10^9$ interactions/s

Bunch crossing frequency: 40MHz
Storage rate ~ 2000 Hz

Discoveries require rare signal extraction in huge data samples of complex detectors – large-scale processing and data management

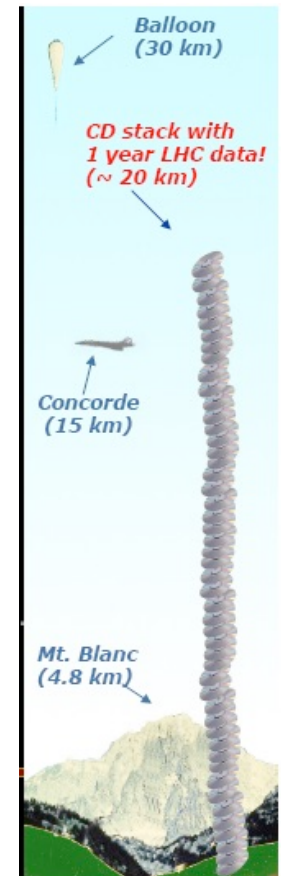

More in Andrew Melo's talk today

Pileup

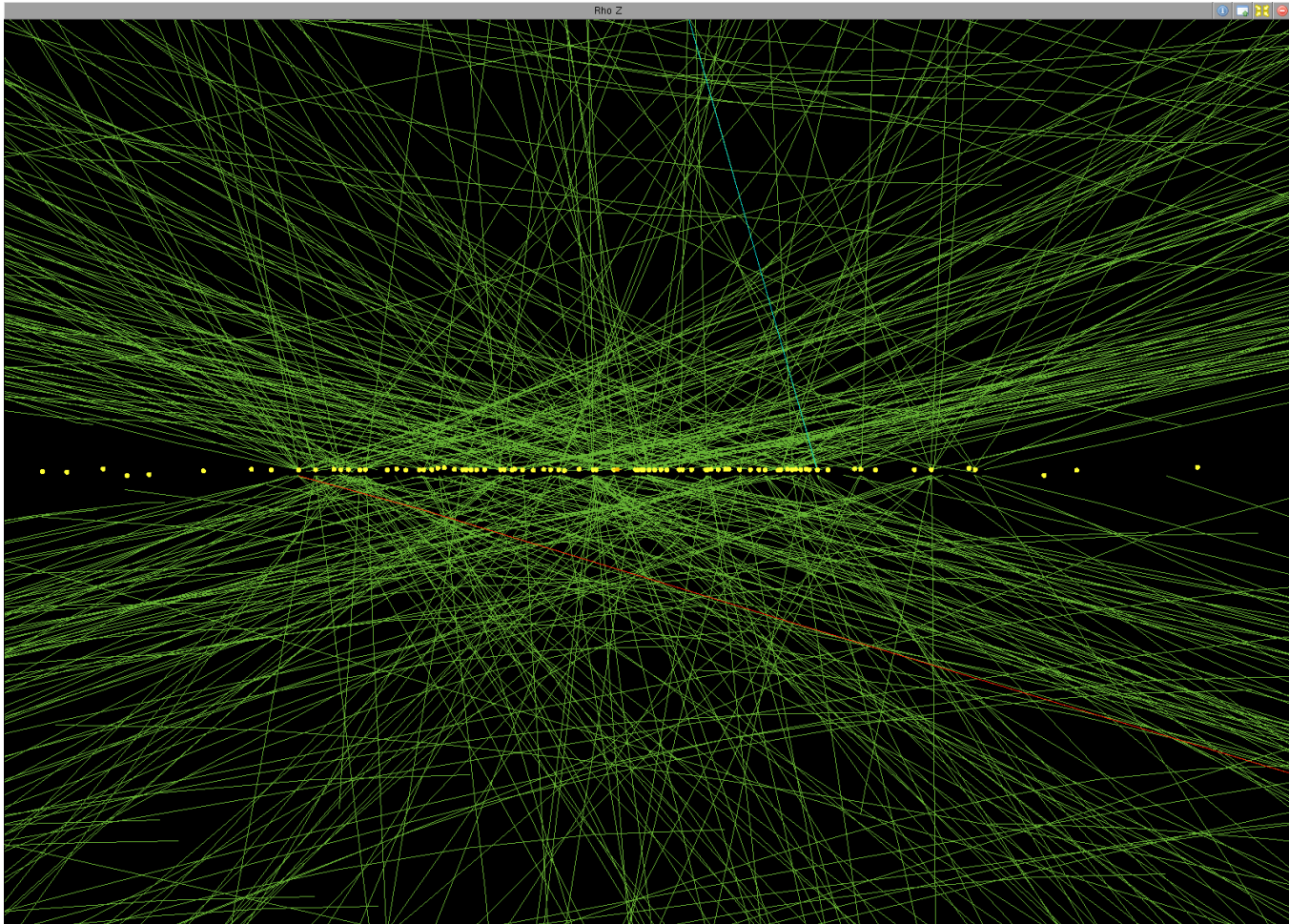

Event from special high pileup run with 78 reconstructed vertices

Average pileup in the 2016 run: 25 – 30

Peak pileup in recent runs exceeded 55!

pp collisions at 14 TeV at $10^{34} \text{ cm}^{-2}\text{s}^{-1}$

25 minbias
events overlap

- $H \rightarrow ZZ$
($Z \rightarrow \mu\mu$)
- $H \rightarrow 4 \text{ muons}$:
("golden")
signature

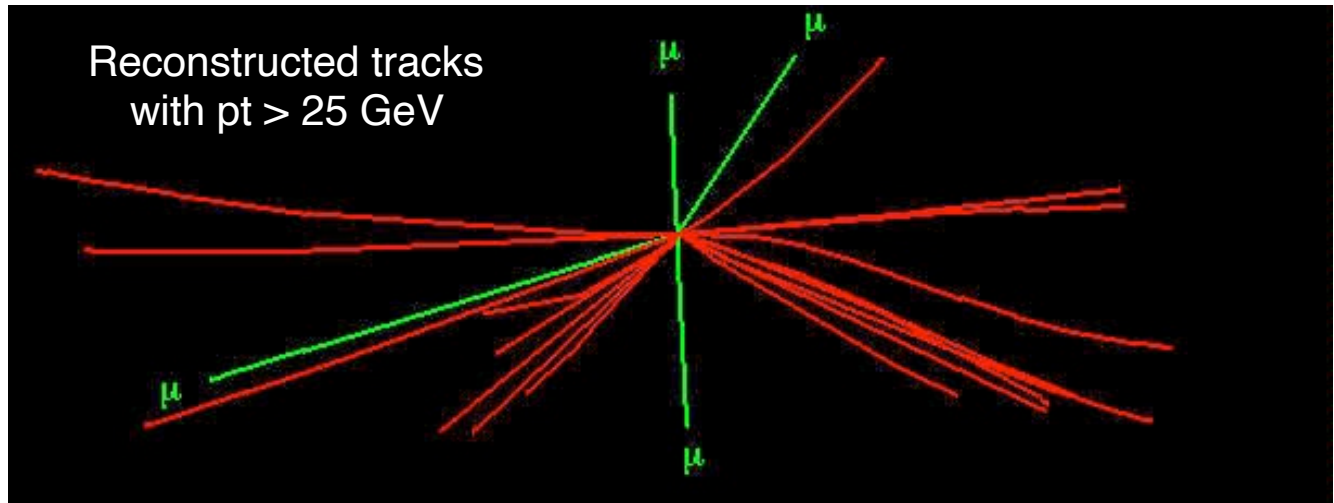
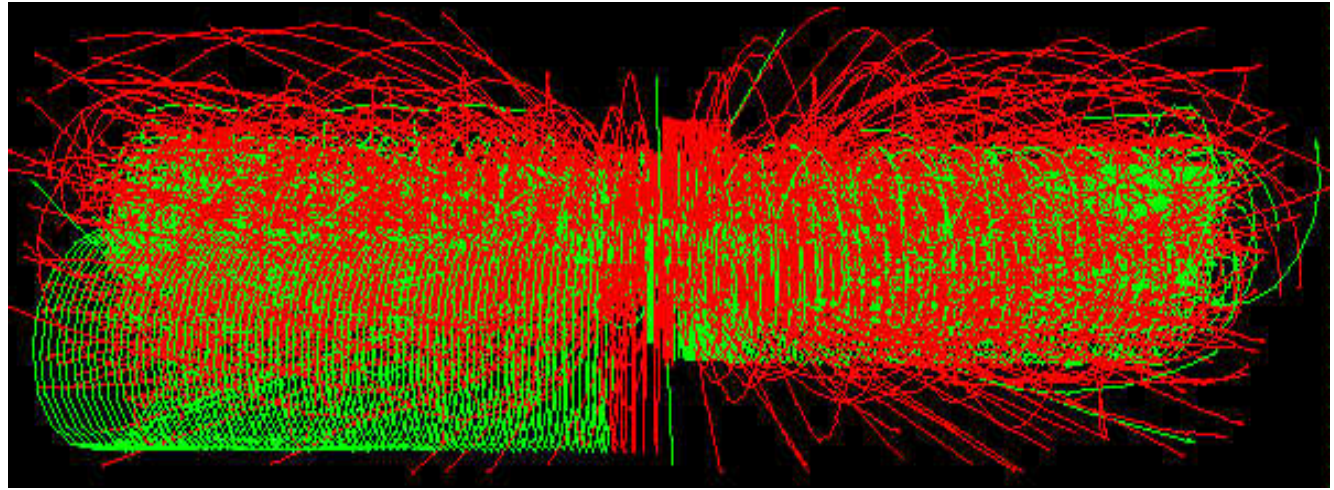

And this (not the H though...) repeats every 25 ns...

The Challenge @ LHC

The Challenge



Where is the needle ?

The Solution

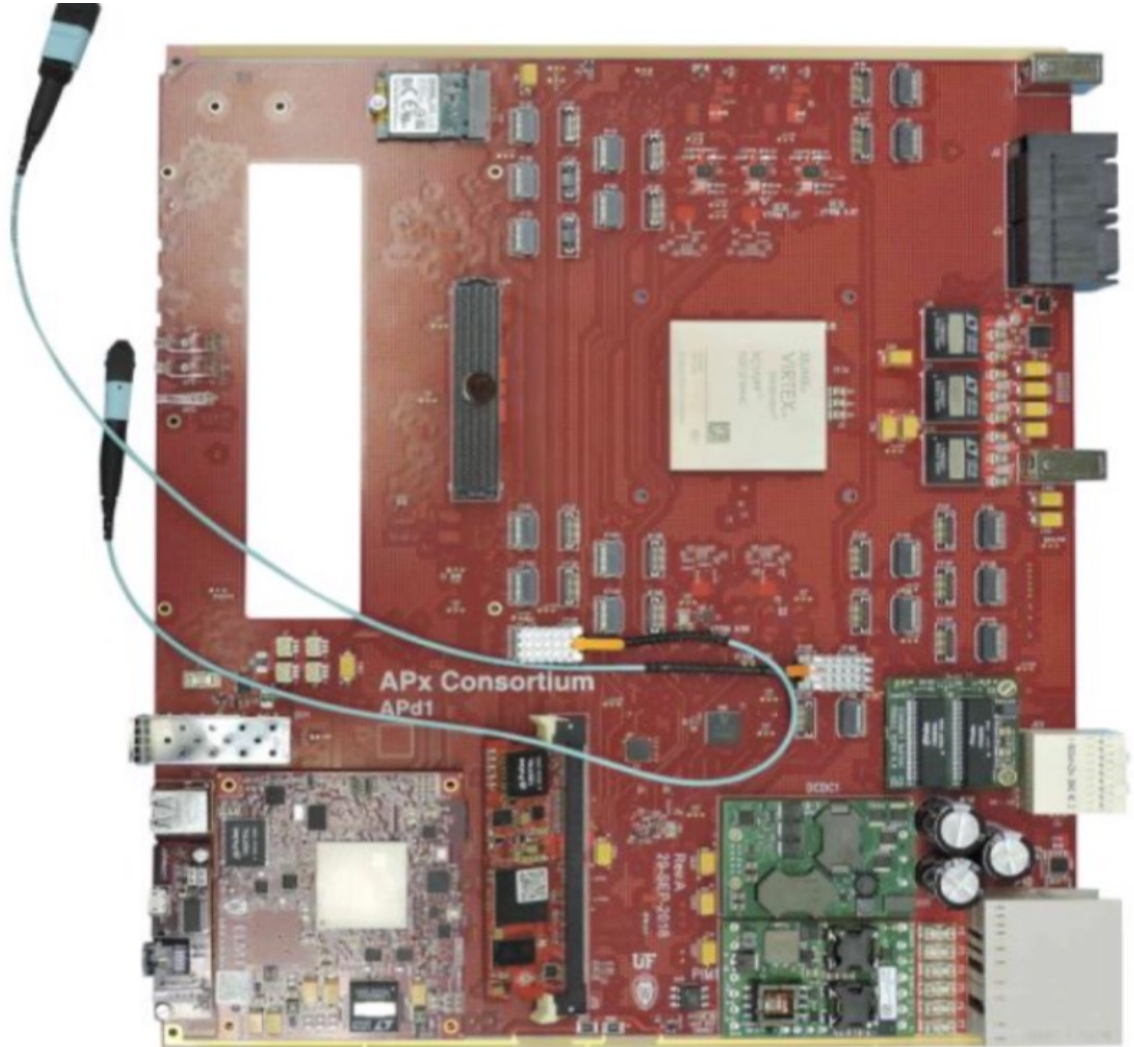

CMS Trigger

CMS has a 2 level trigger system for selecting interesting collision events

1. **Level 1 (L1) trigger:** algorithms running on custom electronics boards
 - Coarse calo & muon info, no tracking info.
 - Hard limits on latency (on-detector buffer size) and total accept rate (readout electronics design)
2. **High Level Trigger (HLT):** algorithms running on commercial CPUs (and GPUs)
 - Hard limit on latency and total bandwidth (transfer data from online file system to storage)
 - *No hard limit on the total rate*

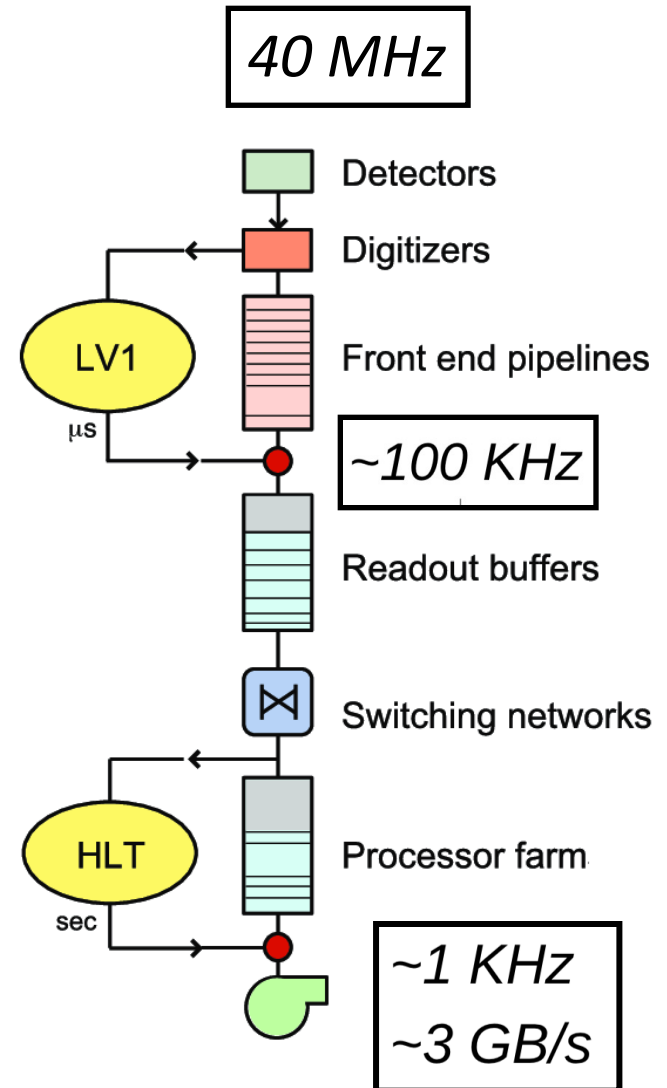

Trigger: tricky business

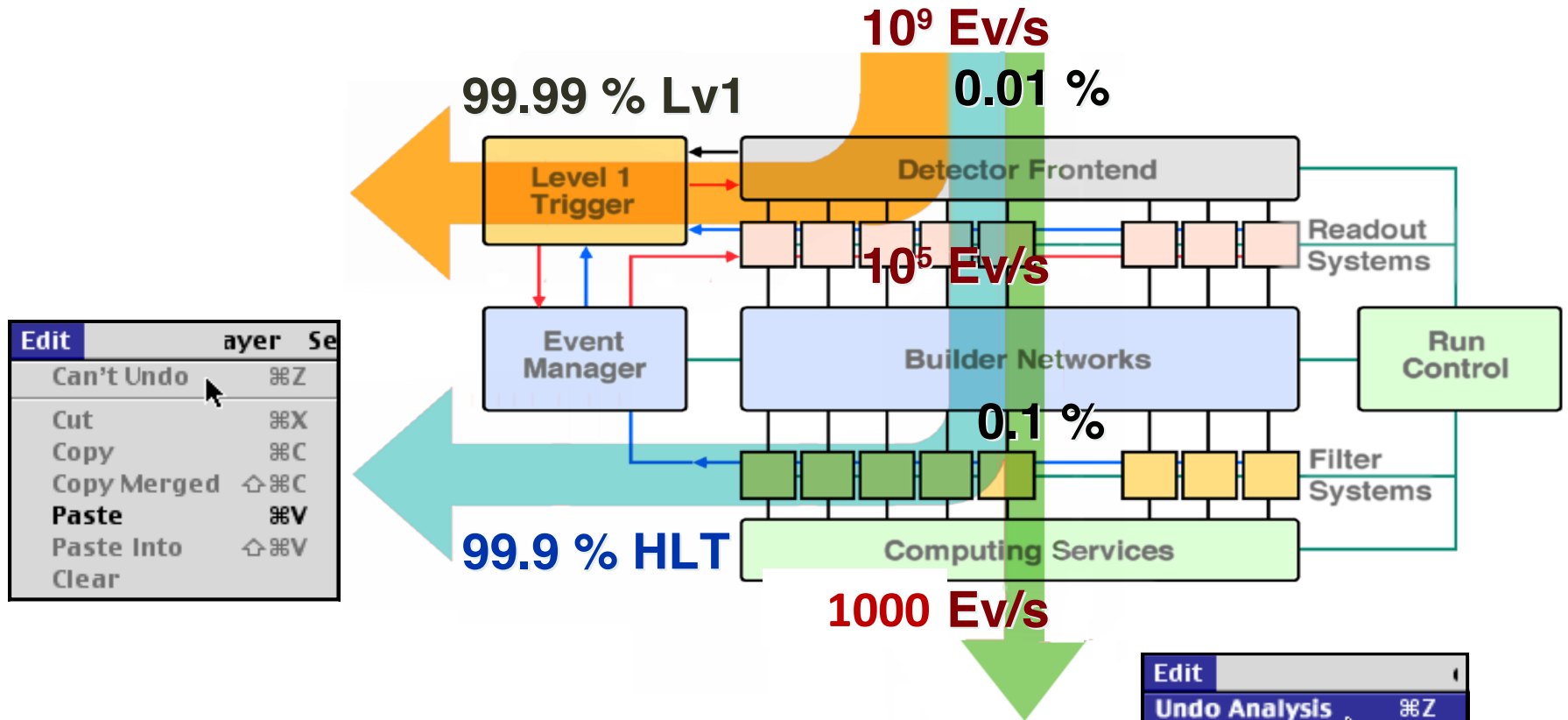

Will your favorite new physics signal be included in the small fraction of selected events?

Despite these challenges....

CERN experiments observe particle consistent with long-sought Higgs boson

Geneva, 4 July 2012. At a seminar held at CERN¹ today as a curtain raiser to the year's major particle physics conference, ICHEP2012 in Melbourne, **the ATLAS and CMS experiments** presented their latest preliminary results in the **search for the long sought Higgs particle**. Both experiments **observe a new particle** in the mass region around 125-126 GeV.

Particle Physics history in the making

The discovery of a SM-like Higgs boson during the LHC Run 1 was a ground-breaking event in physics history

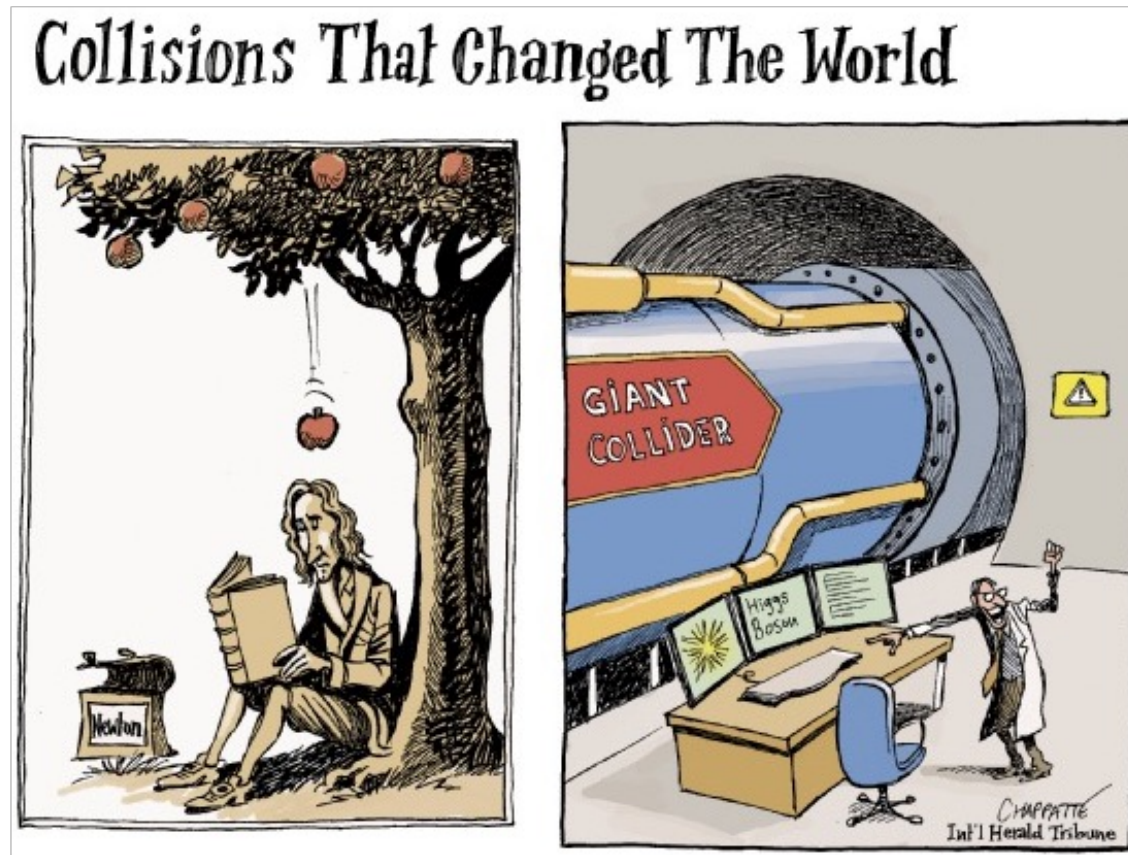

How do you produce a Higgs boson ?

Aside: Feynman Diagram

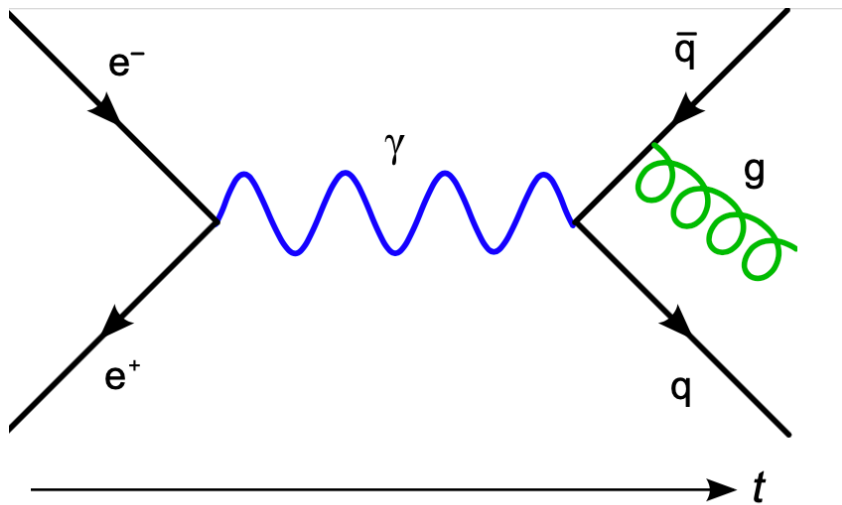

See [video by CMS Collaborator Don Lincoln](#)

Cross sections (σ):

probability that a particular interaction will occur

Unit, by definition: area (cm^2), commonly “barns”, “milli-barns”, “pico-barns” etc

Origin: Uranium nucleus – 10^{-24} cm^2 “as big as a barn”

Cross section

$$L = \int L dt$$

Integrated luminosity (dataset)

$$N = L \cdot \sigma$$

Event rate

Luminosity (machine)

measurement of the **number of collisions** that can be produced in a detector **per cm^2 and per second**

How do you produce a Higgs boson ?

- Dominant production mode: gluon-gluon fusion followed by vector boson fusion (VBF)
- All production modes exploited (gg, VBF, VH, ttH)
 - Latter 3 have smaller cross-sections (σ) but better S/B in many cases

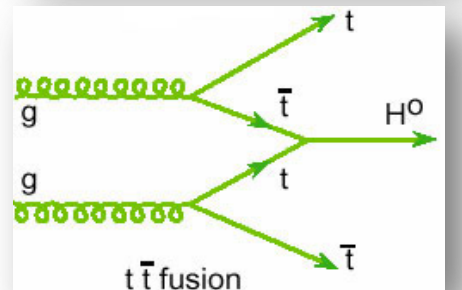
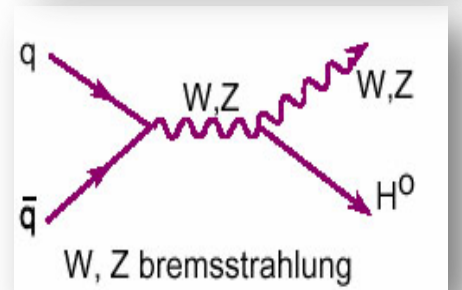
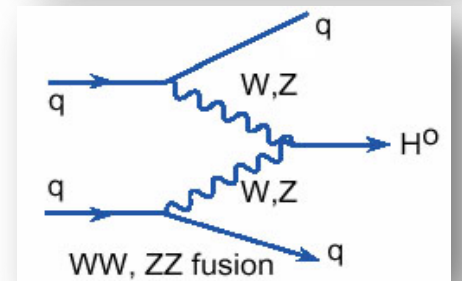
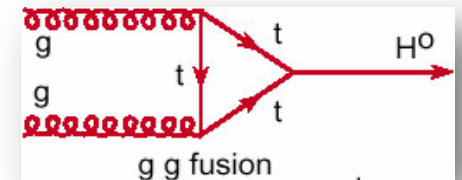

How does a SM Higgs boson decay?

We search for several Higgs decay channels.

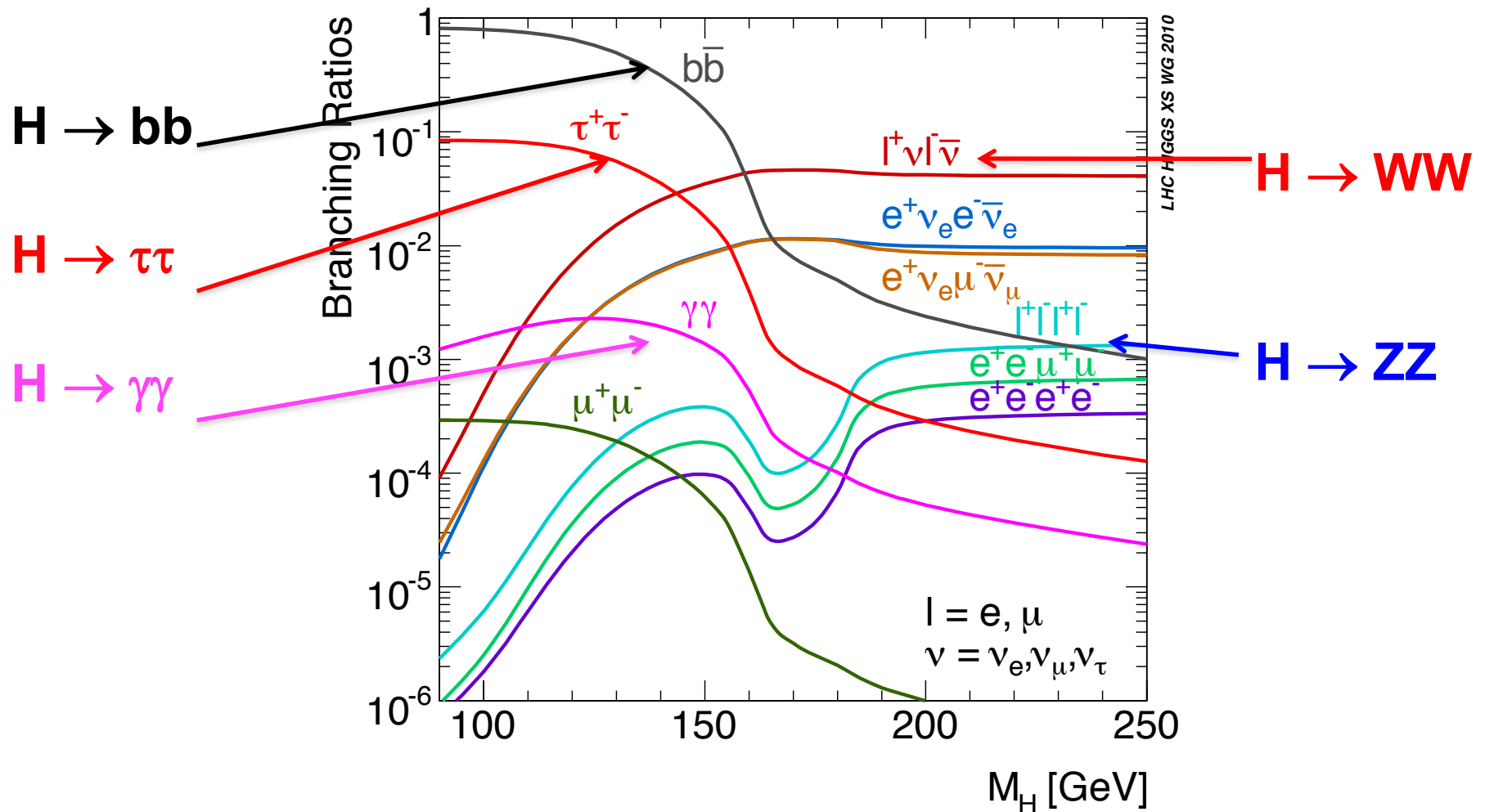

How do we reconstruct particles ?

- Most decay close to the interaction point



CMS Experiment at LHC, CERN
Run 133877, Event 28405693
Lumi section: 387
Sat Apr 24 2010, 14:00:54 CEST

Electrons $p_T = 34.0, 31.9$ GeV/c
Inv. mass = 91.2 GeV/c²

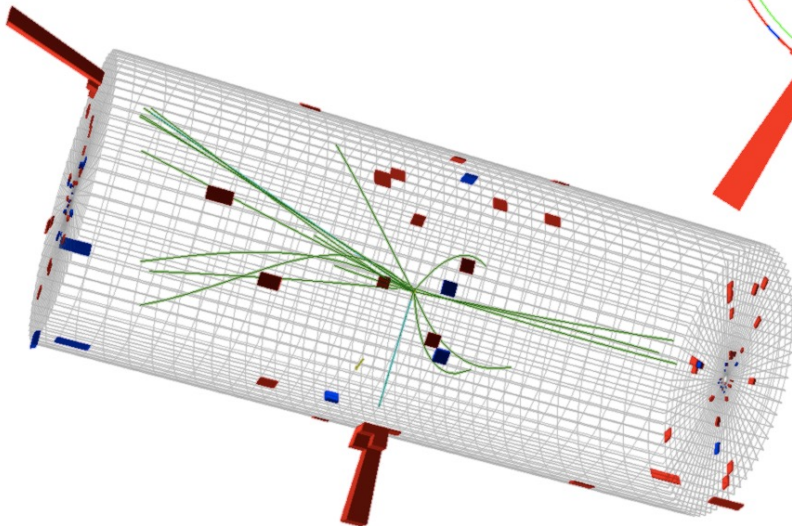
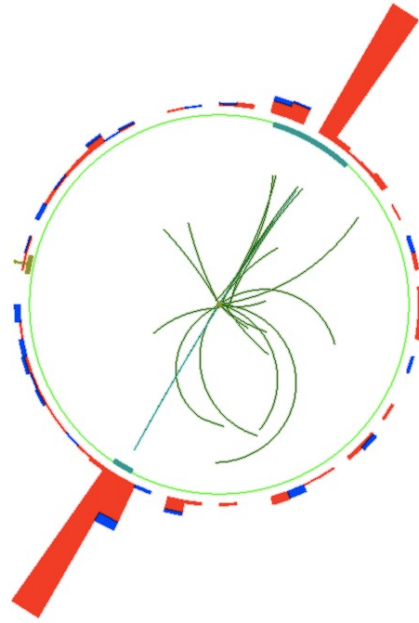

Event vertex (collision point)
is measured using tracks

Note there are several low
momentum tracks
(underlying event)

Electron (−) and Positron (+)
Momentum (P_x, P_y, P_z)
measured in tracker
Energy (E) measured in
the calorimeter

$$E^2 = (mc^2)^2 + (pc)^2$$

$$pp \rightarrow Z + X \rightarrow e^+e^- + X$$

$Z(91 \text{ GeV})$

Candidate 4 Lepton Event

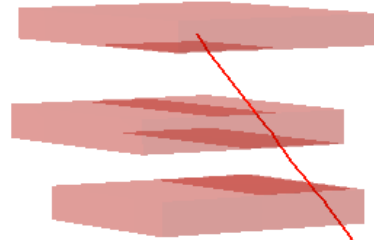

$\mu^+(Z_1) p_T : 43 \text{ GeV}$

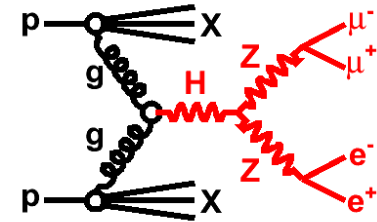

$e^-(Z_2) p_T : 10 \text{ GeV}$

8 TeV DATA

4-lepton Mass : 126.9 GeV

$\mu^-(Z_1) p_T : 24 \text{ GeV}$

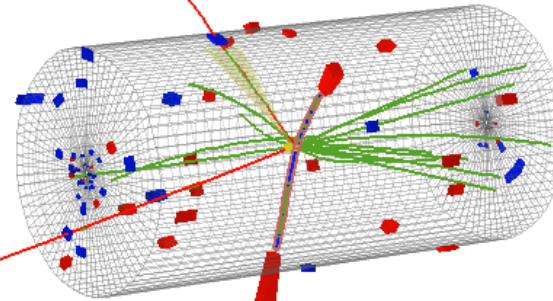
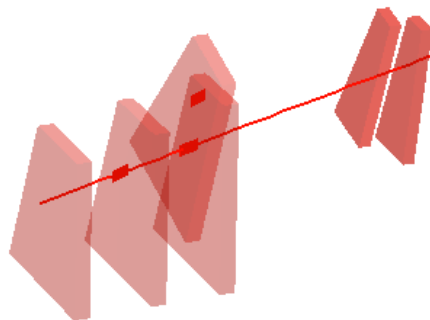

$e^+(Z_2) p_T : 21 \text{ GeV}$

CMS Experiment at LHC, CERN
Data recorded: Mon May 28 01:35:47 2012 CEST
Run/Event: 195099 / 137440354
Lumi section: 115

The Z Boson Invariant Mass Peak

- Particles decaying close to the interaction point
 - Histogram of “invariant mass” of the original heavy particle shows a sharp peak at the mass of the Z (91 GeV)

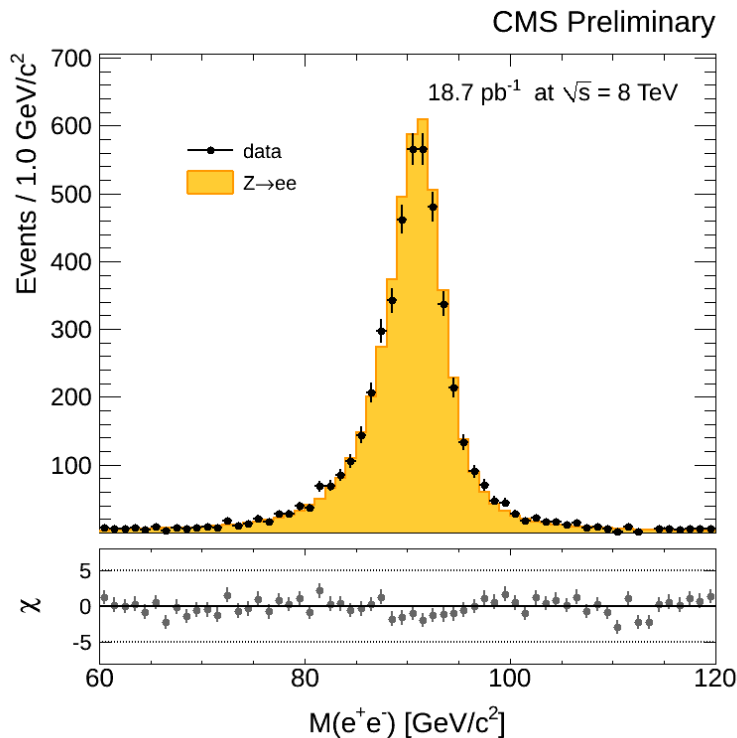

Mass of Electron-Positron Pair

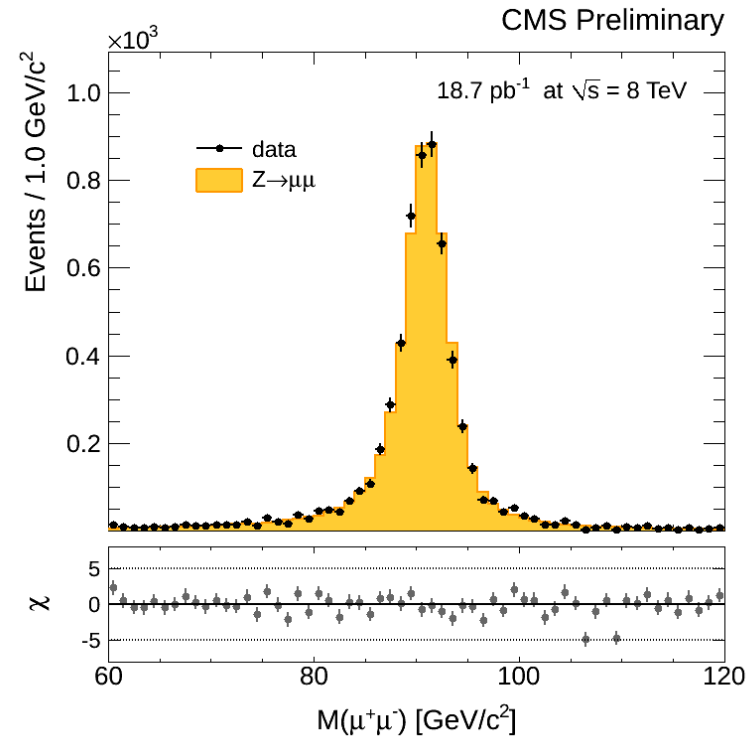

Mass of Muon⁺-Muon⁻ Pair

$H \rightarrow \gamma\gamma$ and $H \rightarrow ZZ$

A clear peak at ~ 125 GeV!

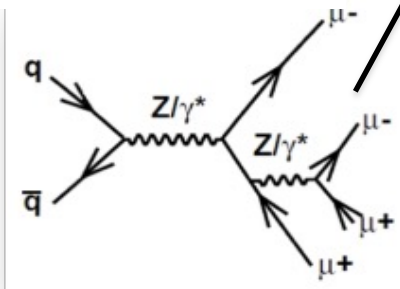
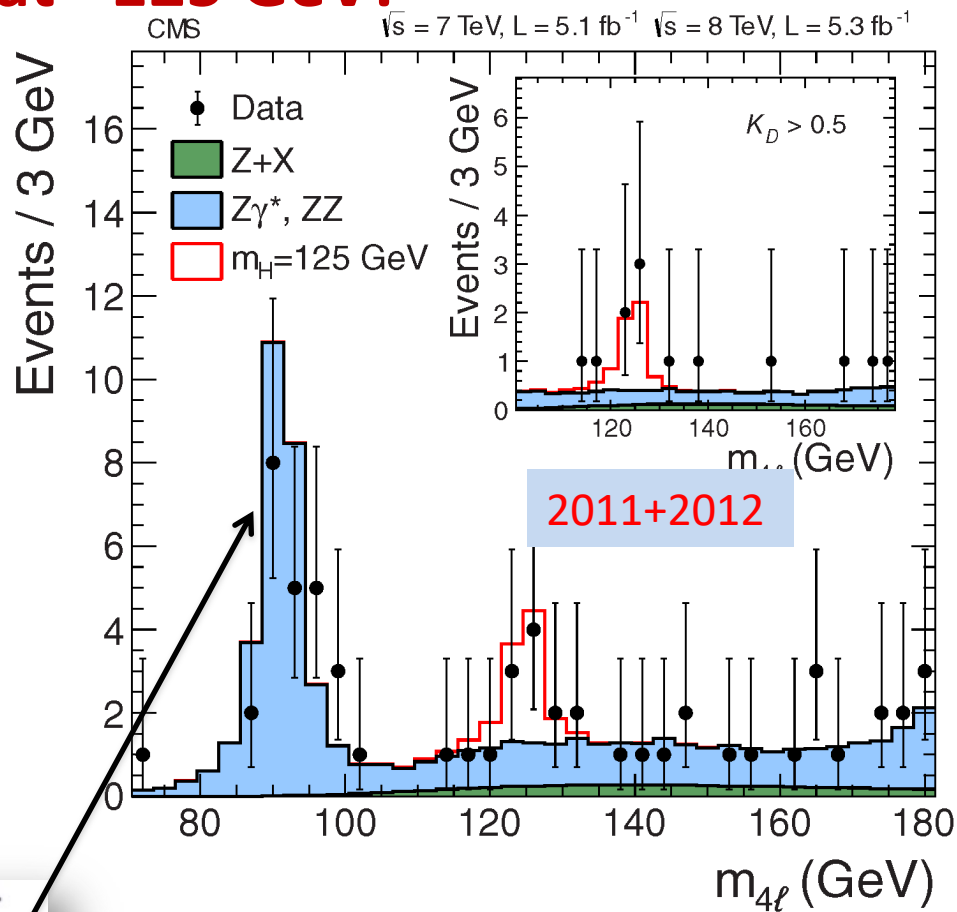
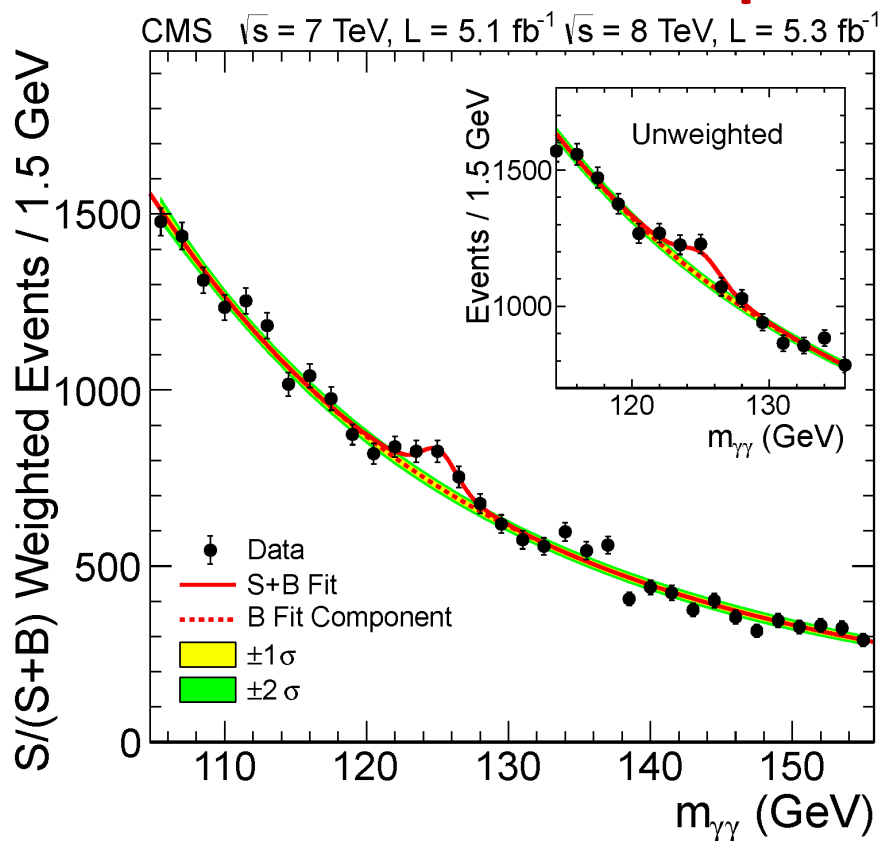

Excellent understanding of the background at all masses



"Greetings Earth-people. We have been monitoring your progress. Now that you have discovered the Higg's boson you are qualified to join the Federation of Advanced Civilisations."

Higgs Production

- Following its discovery, significant effort has been put into characterizing the properties of the Higgs Boson
- Objectives:
 - observe it in as many different ways as possible to measure its properties

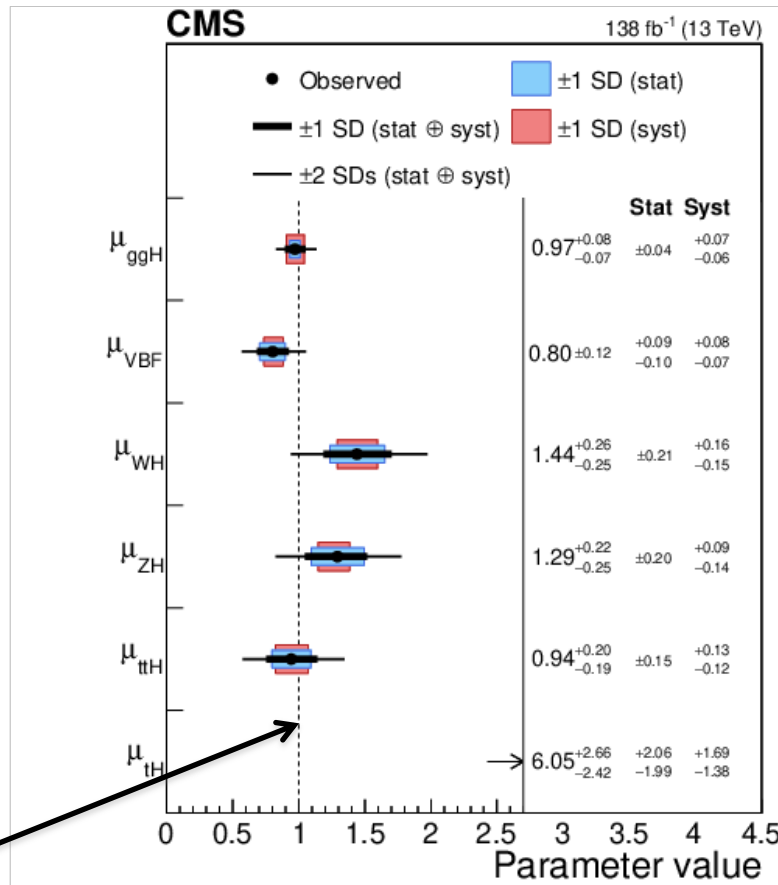

1 is perfect agreement with predictions

Tests all parts of the theory!

μ = measurement/prediction

Higgs Decay

- Following its discovery, significant effort has been put into characterizing the properties of the Higgs Boson
- Objectives:
 - observe it in as many different ways as possible to measure its properties

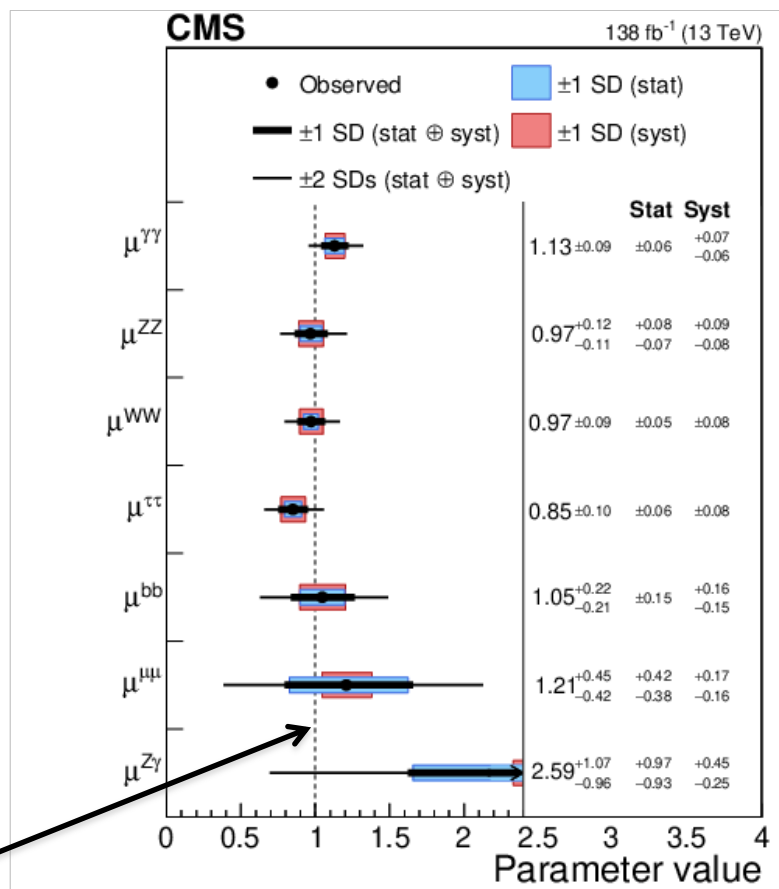

Tests all parts of the theory!

1 is perfect agreement with predictions

Key questions: post-discovery era

- Is it a Higgs boson or the Higgs boson ?
 - Is it elementary or composite ?
 - Does it interact with itself ?
- How does the Higgs couple to light particles (e.g. $h \rightarrow J/\Psi + \gamma$)
- And how does it couple to muons ?
- Why is the Higgs so light ?
- Are there additional Higgs bosons ?
- Are there exotic Higgs decays ?

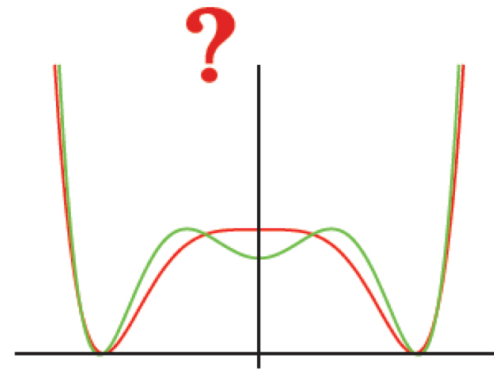
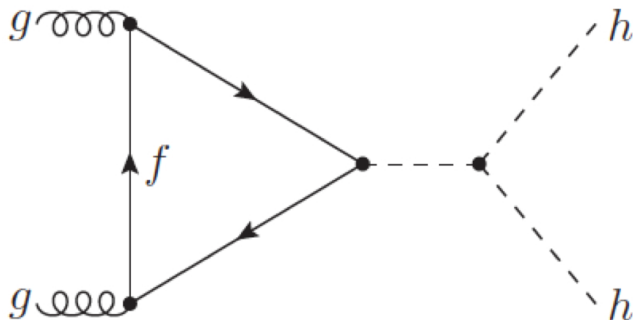

Where are we today ?

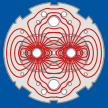

LHC / HL-LHC Plan

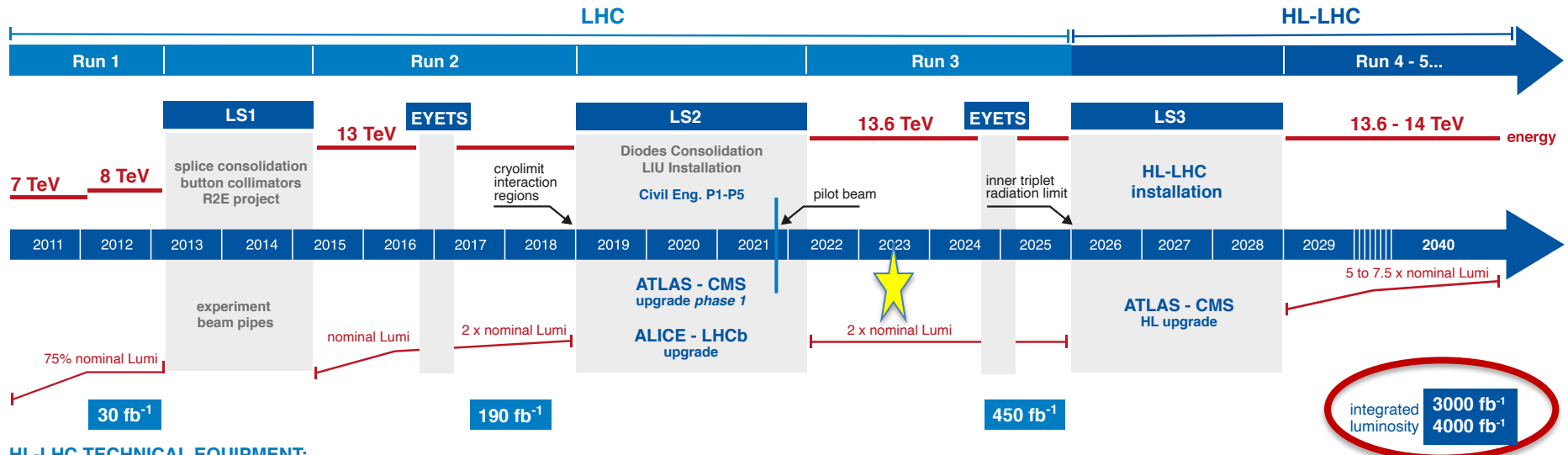

HL-LHC TECHNICAL EQUIPMENT:



HL-LHC CIVIL ENGINEERING:



Note 95% of the total LHC data still to come (and be studied)!

CMS Luminosity

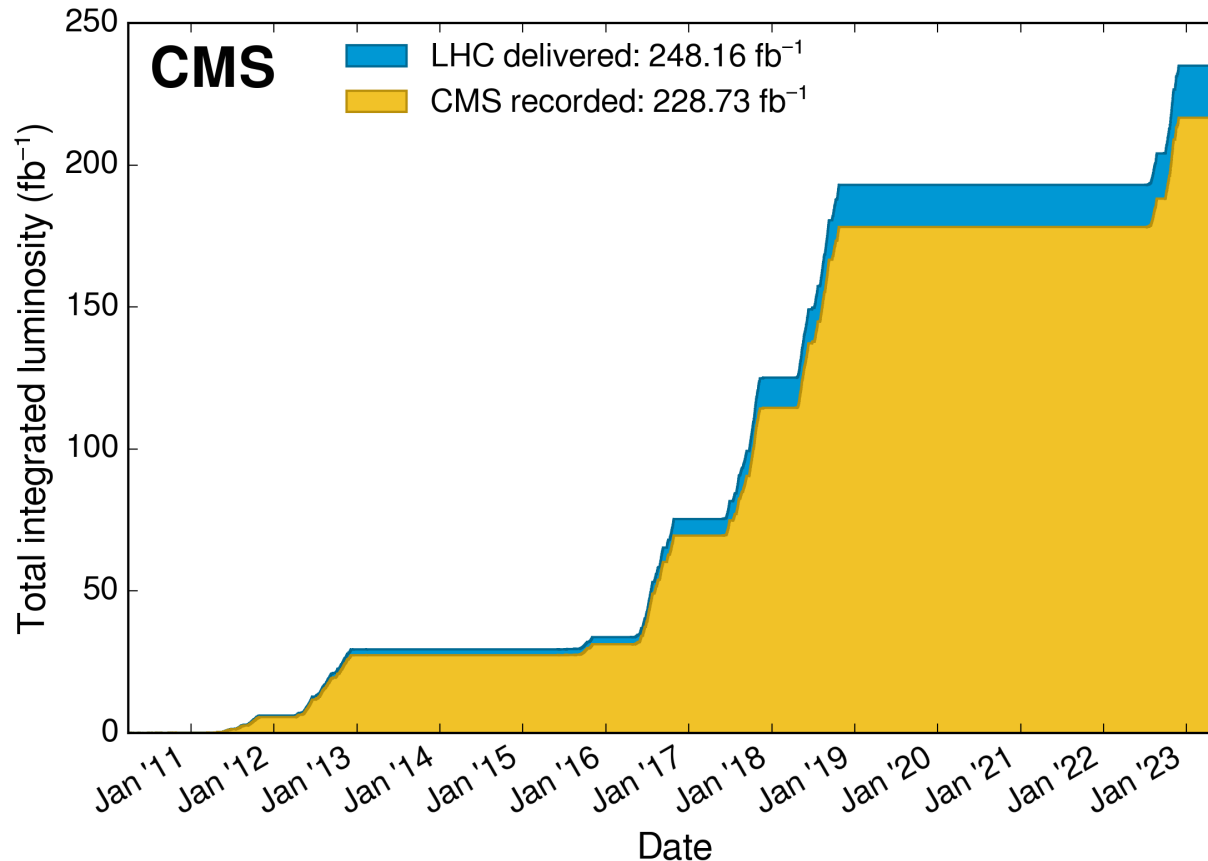

- Excellent, record-breaking performance of the LHC
 - Exceeded even the most optimistic projections
- CMS data collection efficiency typically > 90%

Quest for new physics

- Precision measurements of SM processes
 - Understand SM backgrounds, look for deviations or anomalies
- Searches/measurements of rare SM processes
 - Take advantage of the large LHC datasets and look for (significant) enhancement from beyond-the-SM (BSM) particles

**SM as a tool
for discovery**

- Direct searches for BSM particles
 - Go in new directions with new models, challenging topologies, enlarged parameter space → innovate!

**Exploring the
unknown**

Take advantage of state-of-the-art analysis methods, data mining, machine learning, new technologies, upgraded detectors...

CMS Publications

Show all Total Exotica Standard Model Supersymmetry Higgs Top Heavy Ions

B and Quarkonia Forward and Soft QCD Beyond 2 Generations Detector Performance

1197 collider data papers submitted as of 2023-05-31

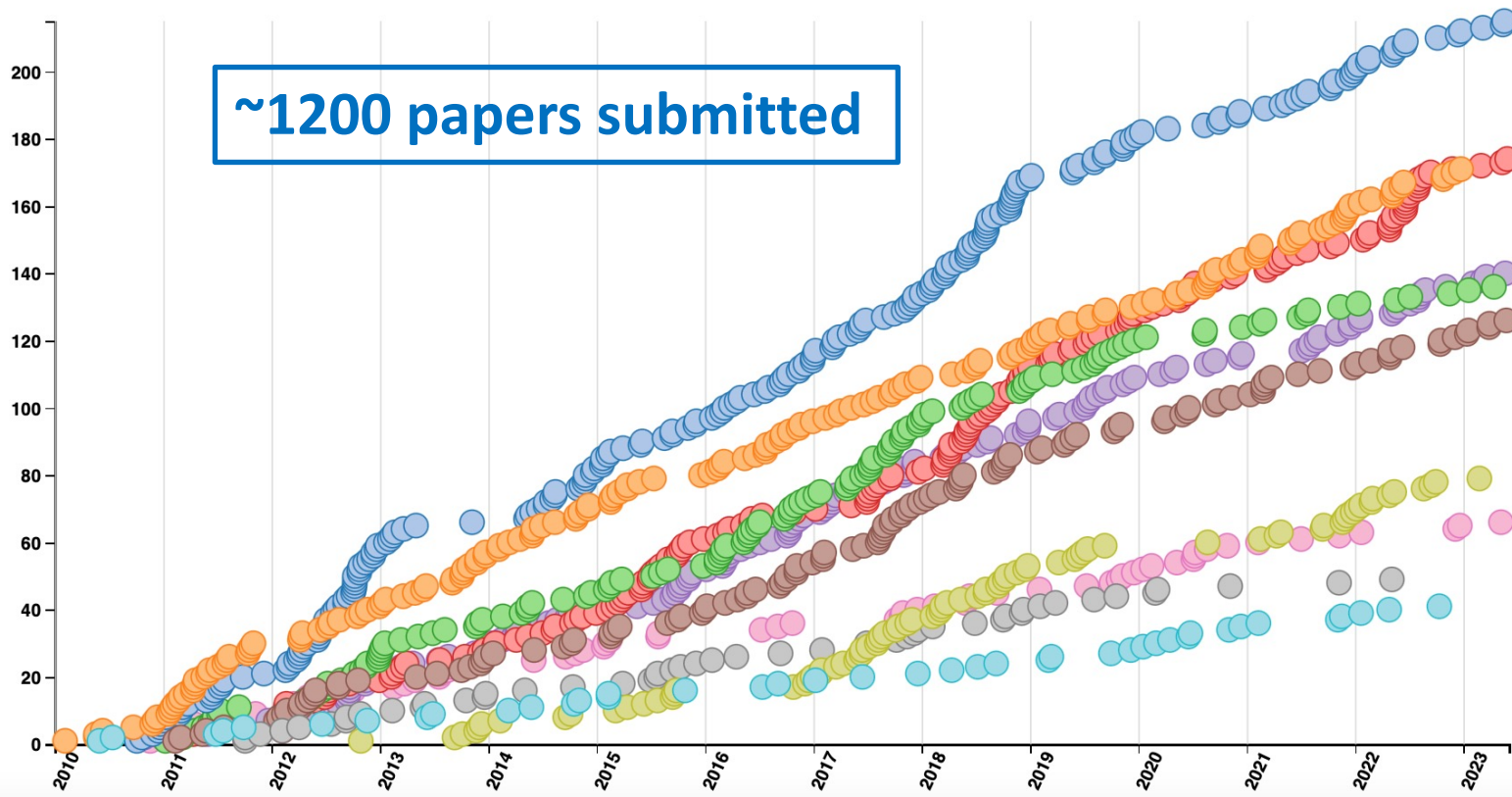

<https://cms-results.web.cern.ch/cms-results/public-results/publications-vs-time/>

CMS Physics Briefings: <https://cms.cern/tags/physics-briefing>

Overview of CMS cross section results

18 pb⁻¹ - 138 fb⁻¹ (7.8,13,13.6 TeV)

CMS preliminary

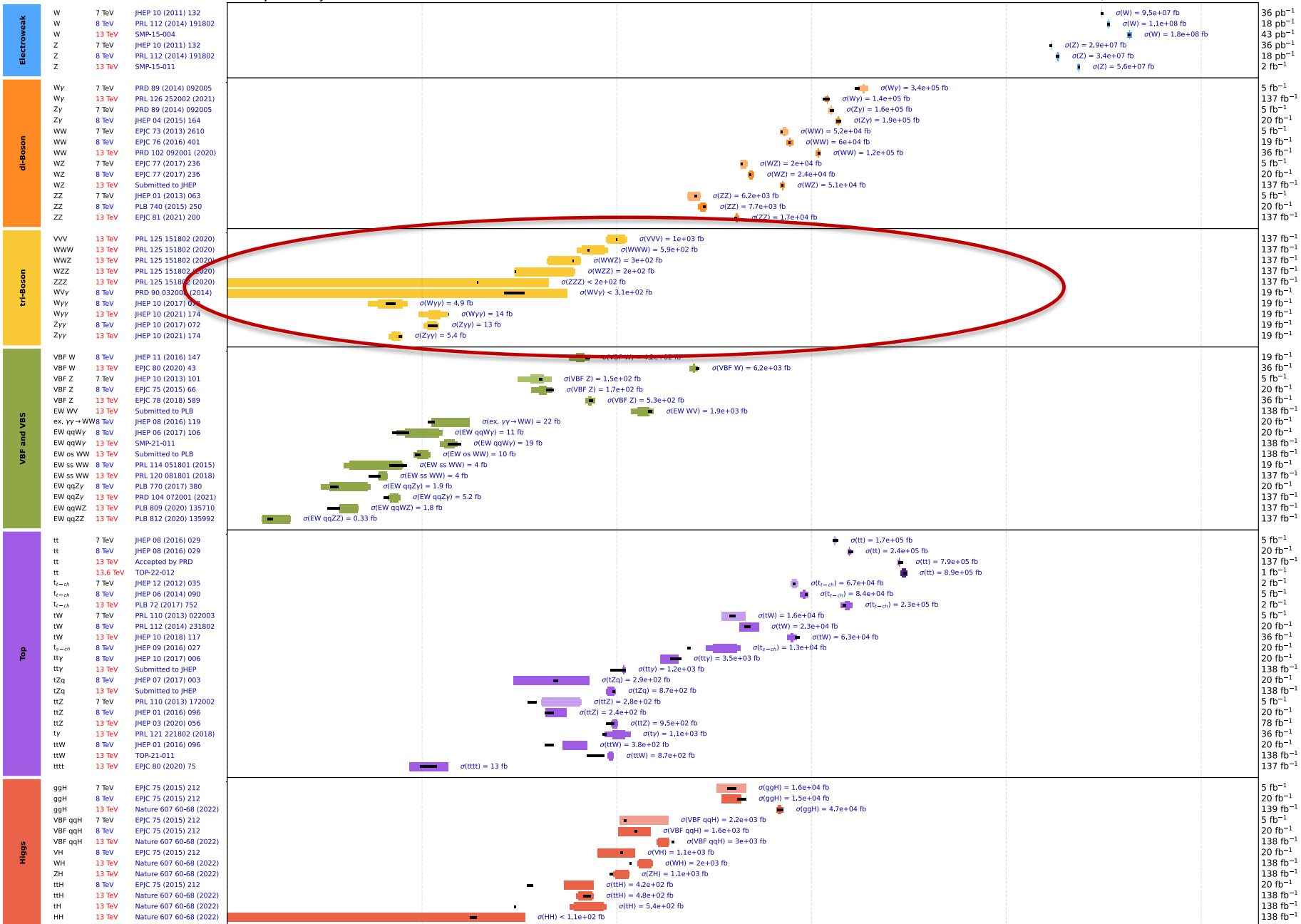

1.0e-01

1.0e+01

1.0e+03

1.0e+05

1.0e+07

1.0e+09

Measured cross sections and exclusion limits at 95% C.L.

Inner colored bars statistical uncertainty, outer narrow bars statistical+systematic uncertainty

σ [fb]

Light colored bars: 7 TeV, Medium: 8 TeV, Dark: 13 TeV, Darkest: 13.6 TeV, Black bars: theory prediction

See here for all cross section summary plots

September 2022

Precision measurements of rare processes

- Large datasets allow us to test the SM in complementary ways
 - multi-differential cross-section measurements
 - First-time sensitivity to rare multi-boson final states and production mechanisms

Starting to be sensitive to higher order theoretical corrections;

Still room for surprises!

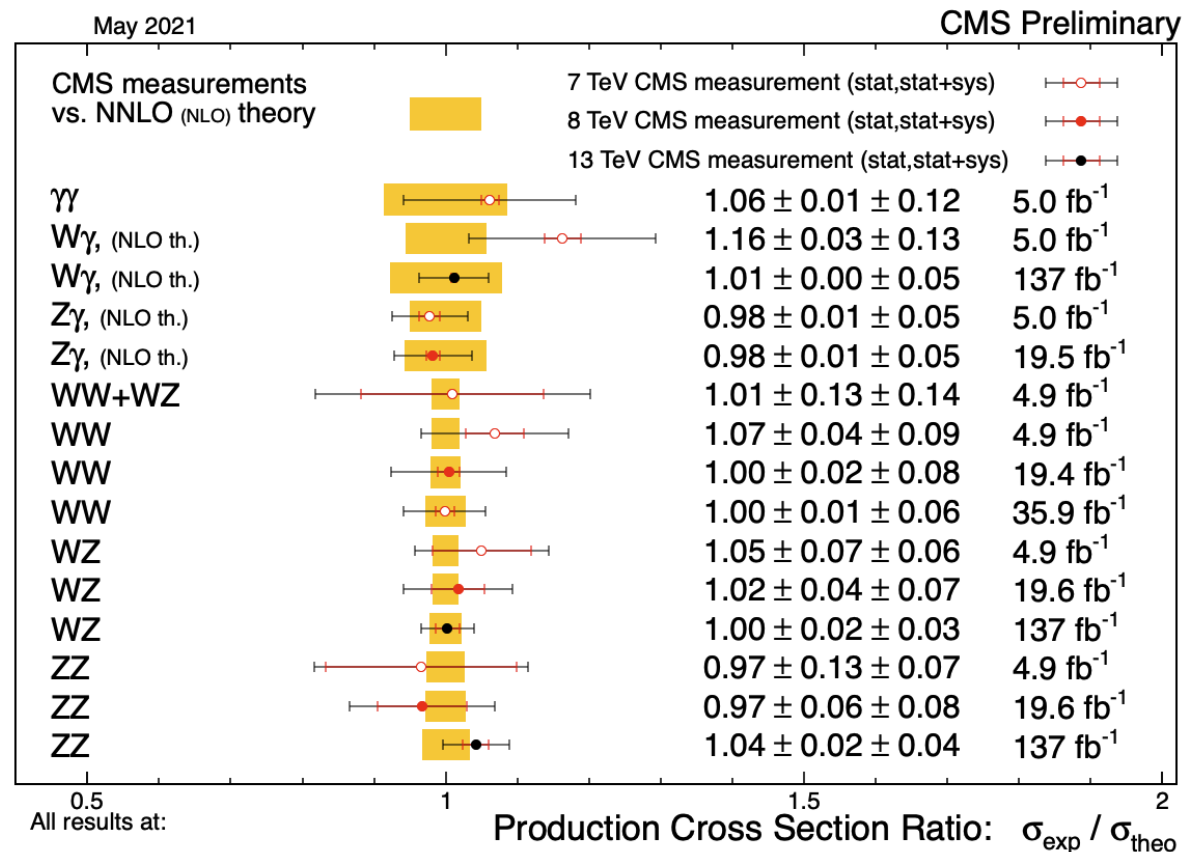

Overview of CMS cross section results

18 pb⁻¹ - 138 fb⁻¹ (7.8,13,13.6 TeV)

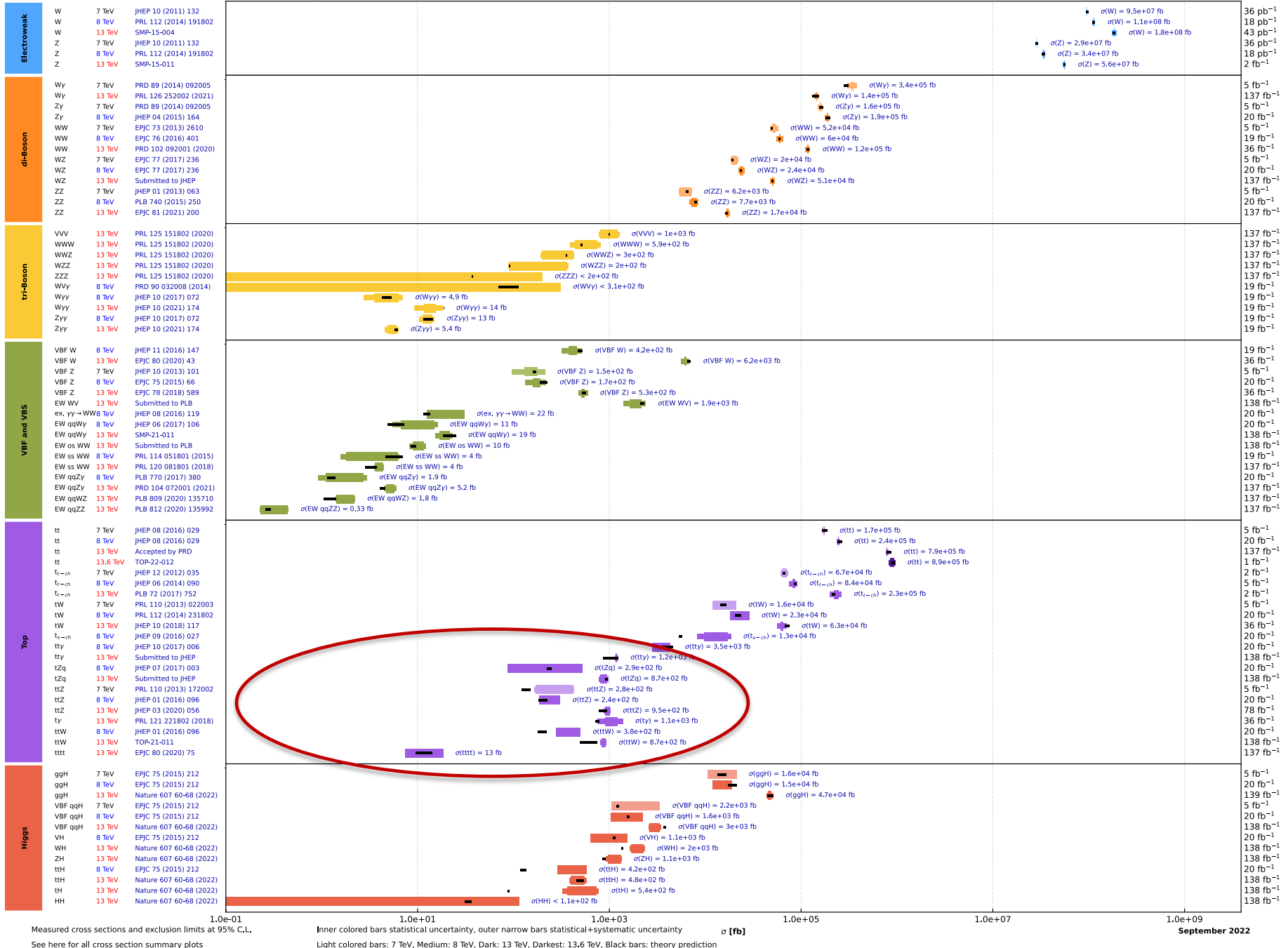

Top Quark Physics

Over ~25 years since its discovery, the top quark is still one of the hottest topics...



March 2, 1995
Ramsey Auditorium (Fermilab)



DZero experimenters submit their
top quark discovery paper to
Physical Review Letters

Precision Top Quark Physics

Over ~25 years since its discovery, the top quark is still one of the hottest topics...

LHC: a top quark factory!

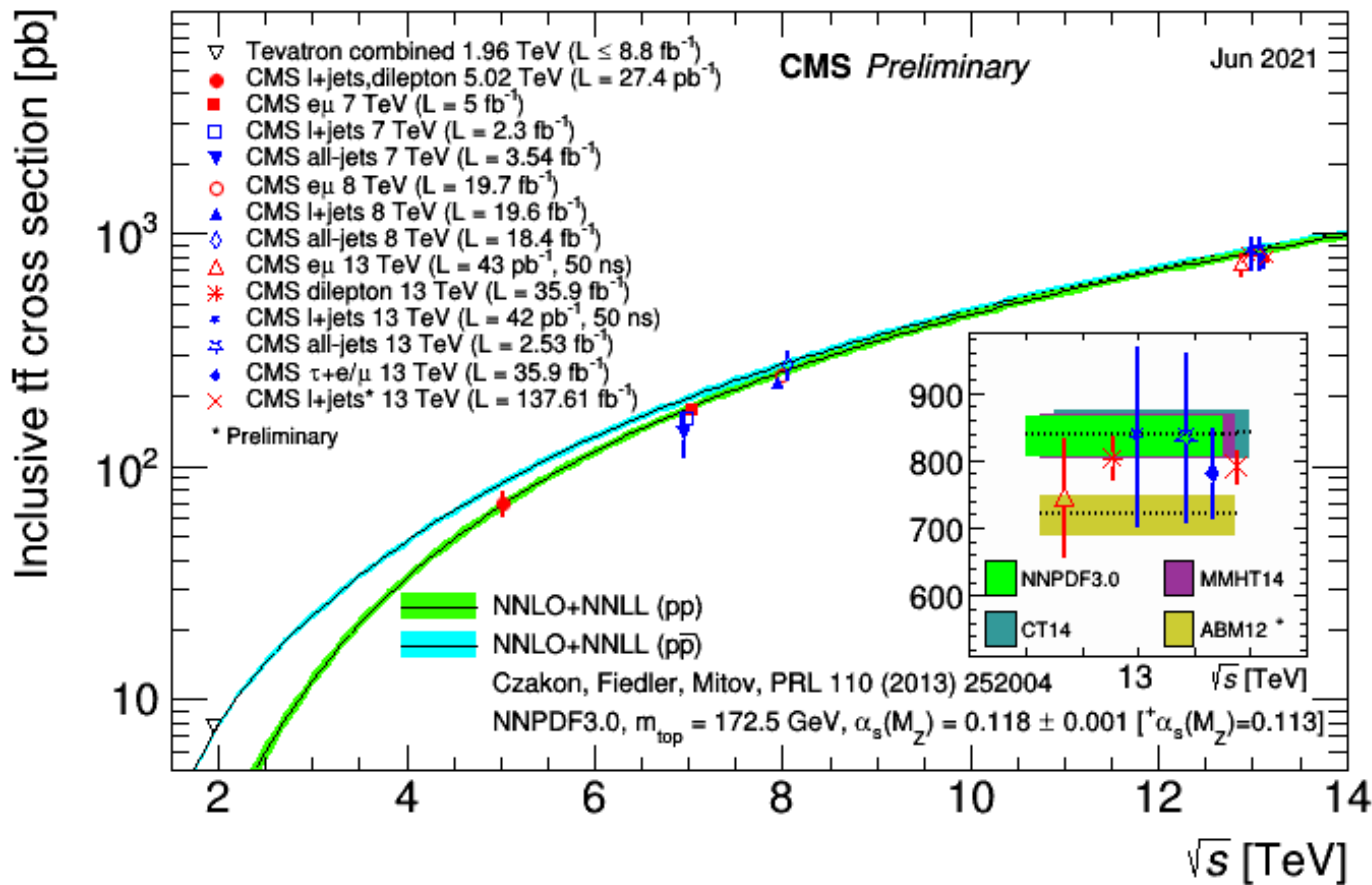

Inclusive cross section well understood;

Agrees with higher order theoretical predictions

Top evolution



CMS Experiment at LHC, CERN
 Data recorded: Tue Jul 14 11:47:11 2015 CEST
 Run/Event: 251721 / 22303466
 Lumi section: 21

t

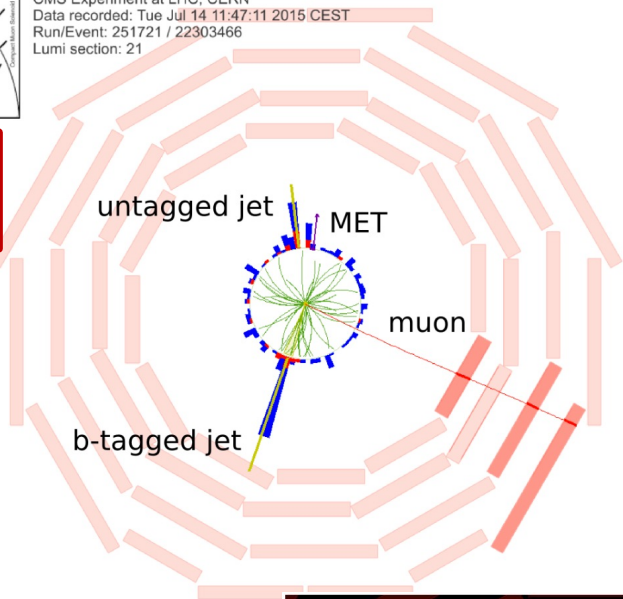

CMS Experiment at LHC, CERN
 Data recorded: Wed Jul 8 19:26:24 2015 CEST
 Run/Event: 251244 / 83494441
 Lumi section: 151
 Orbit/Crossing: 39572626 / 358

tt

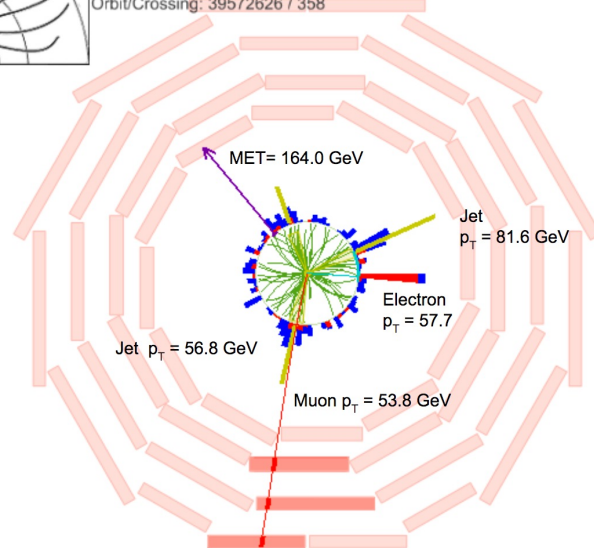

What about ttt production ?

Analysis currently ongoing

tttt

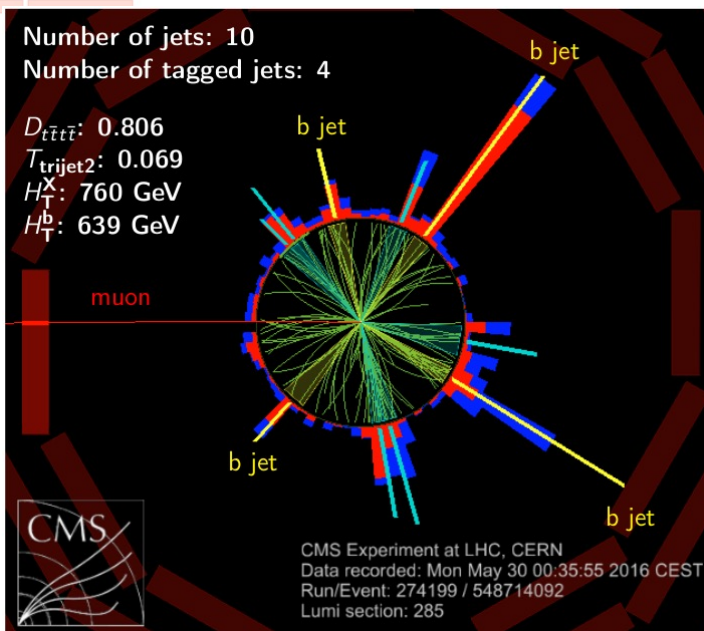

Anomalies

- Extensive program of measurements and searches during Run 2
- Statistical fluctuations are expected to occur
 - given all the different search regions, observables, challenges of background estimation techniques, understanding of systematics etc.
- Some of these “anomalies” have gone away with more data, others persist or appear in the full Run 2 dataset, and others might be due to our incomplete understanding of the SM
 - Imp. to keep an eye on them as we plan analyses for Run 3 and HL-LHC

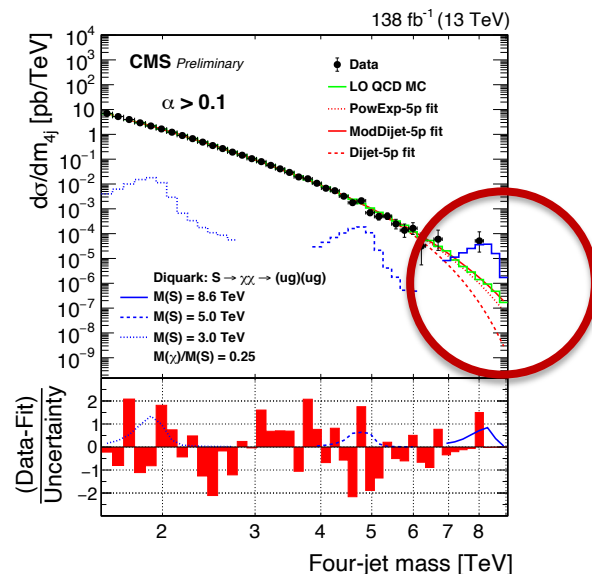
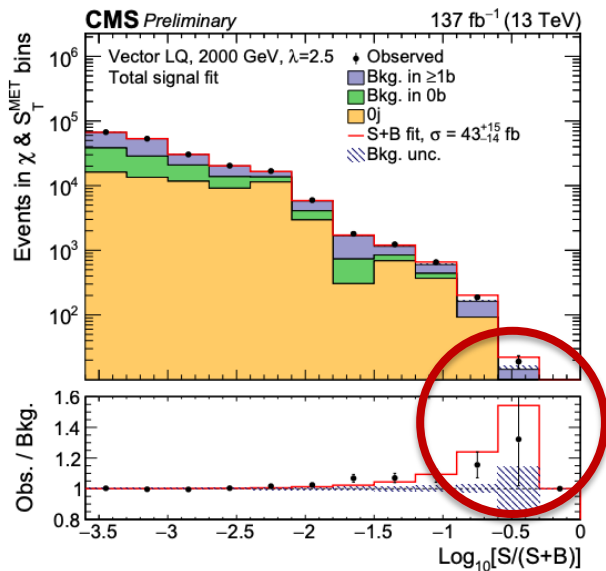

Pairs of di-jets

- Search for resonant and non-resonant pairs of dijets
 - Excess at 8 TeV with local (global) sig of 3.9σ (1.6σ)

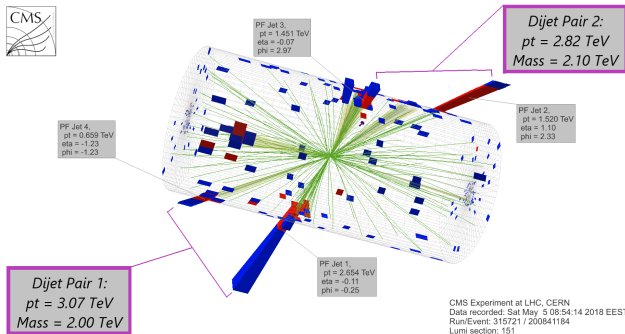
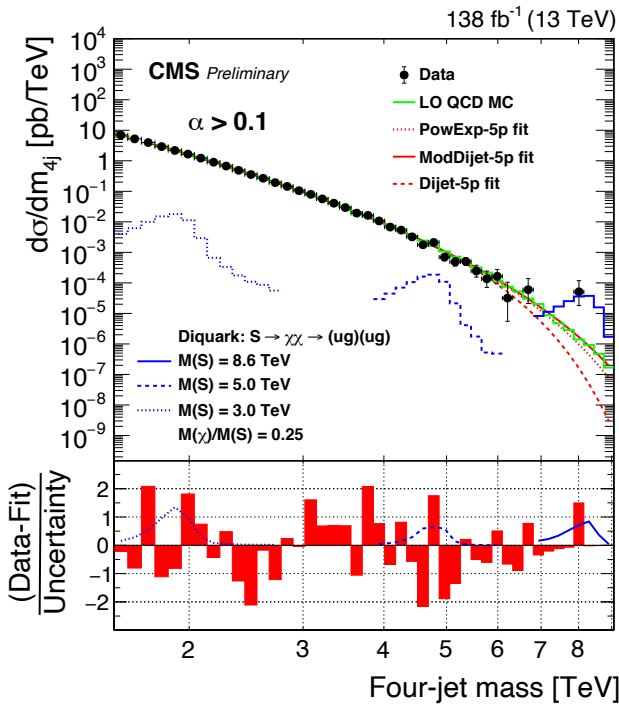

An 8 TeV diquark or coloron that can decay into a pair of ~ 2 TeV vector-like quarks?

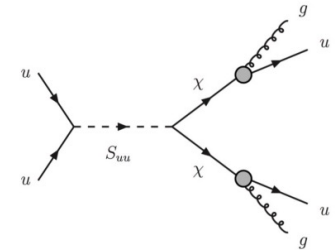

CMS-PAS-EXO-21-010

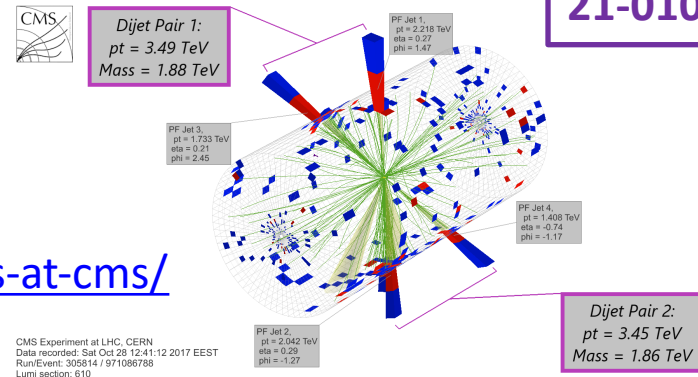

<https://cerncourier.com/a/dijet-excess-intrigues-at-cms/>

CMS Experiment at LHC, CERN
Data recorded: Sat Oct 20 12:41:12 2017 EEST
Run/Event: 305814 / 971086788
Lumi section: 610

New channels, novel techniques, creative analyses

Rich and diverse search landscape

- Big inclusive searches complemented by dedicated searches that target gaps in coverage
- Incorporate machine learning for Higgs, b, charm, top tagging
- Improve lepton reconstruction/ID for compressed spectra w/ low p_T leptons; improve analysis techniques, jet substructure
- Challenging topologies
- Unconventional analyses

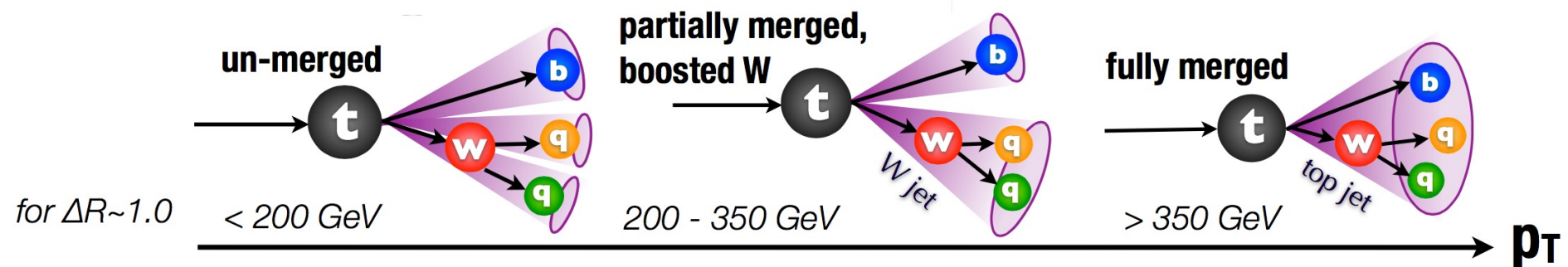

Non-conventional final states

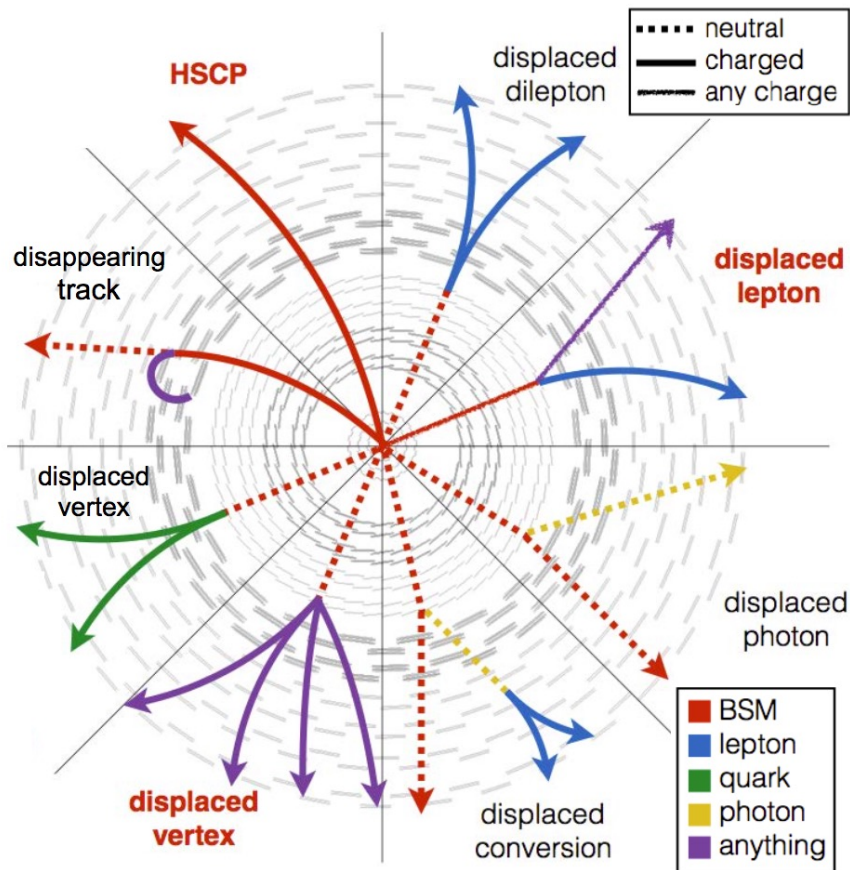

Credits: J. Antonelli

New and rich phenomenology:

Very weakly coupled to SM

Long-lived particles

Masses below the EW scale

Searches need to often overcome challenges in trigger, reconstruction & background estimation

Need to deal with unusual backgrounds (e.g. beam-induced backgrounds)

Excellent detector understanding is absolutely critical

Important to take advantage of several topologies and use existing detector in creative ways

“Scouting”

Traditional trigger algorithms usually require high thresholds (e.g. on p_T and mass) to reduce the event rate, and then readout the full event info.

- The limit is the total bandwidth
 - Can reduce the event size to collect events at a higher rate (i.e. lower thresholds)
 - reduction of event size to O(10kB) allows trigger rates of several kHz
- Reconstruct at the HLT stage, keeping limited information (HLT objects)
 - needs adequate calibration @ HLT and validation against full reconstruction

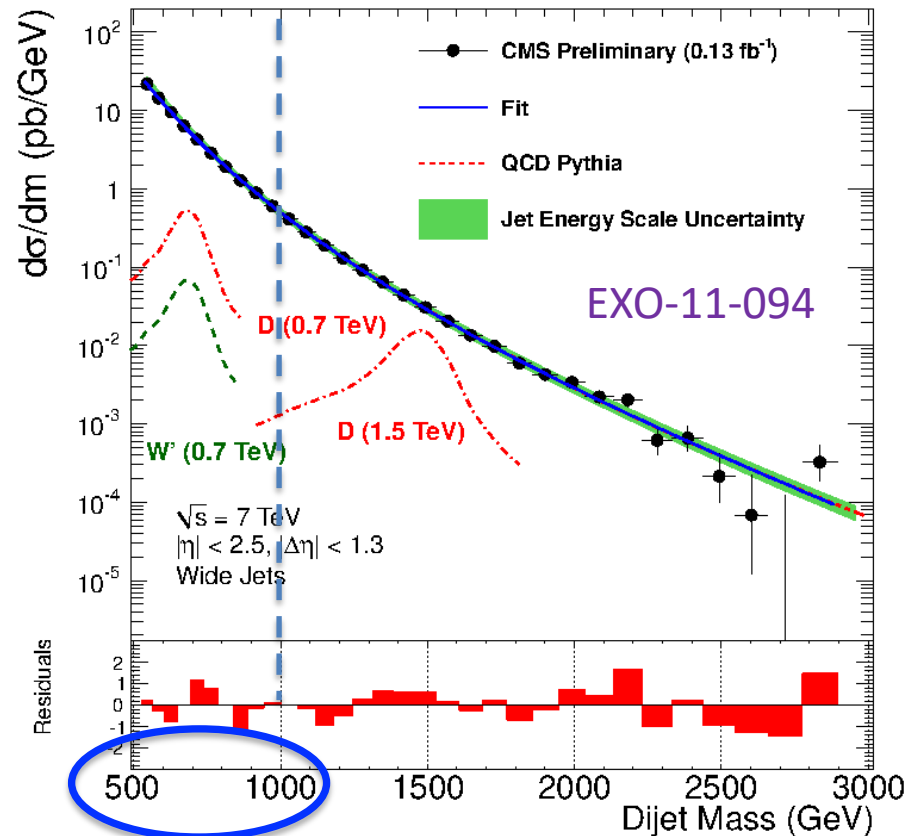

Scouting approach extended
the reach below 1 TeV

Summary & Outlook

- The ~13 years of LHC operation has been one amazing ride!
 - Discovery of the Higgs boson
 - Now using the Higgs as a tool for discovery
 - Huge amounts of BSM parameter space ruled out
 - At the same time, innovative strategies for triggering, data-taking and analysis are providing access to previously unexplored territory!
 - Some interesting excesses – being pursued with full Run 2 datasets (and Run 3)
- An exciting time to develop and implement new ideas
 - Go in directions where no one has gone before!
- **95% of the total LHC data still to come (and be studied)!**
- **Come join our quest to answer the unsolved mysteries of nature...**

When questioned during a congressional hearing in 1969 about what the activity carried out at Fermilab was doing for the national defense, Director Robert Wilson replied:

It only has to do with the respect with which we regard one another, the dignity of men, our love of culture....

It has to do with, are we good painters, good sculptors, great poets?

I mean all the things that we really venerate and honor in our country and are patriotic about.

It has nothing to do directly with defending our country except to help make it worth defending.

