

# Introduction à l'information quantique

Quantum Workshop for High School Students

Su Yeon Chang



QUANTUM  
TECHNOLOGY  
INITIATIVE

# Introduction

1945

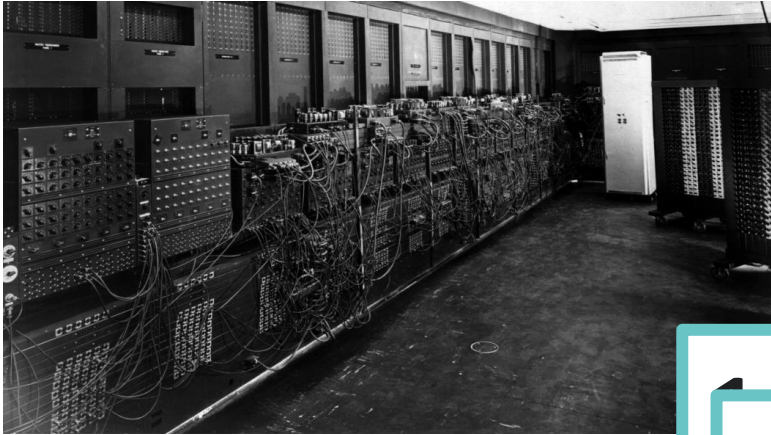

Aujourd'hui



## Volume of data created, captured, copied, and consumed worldwide



The volume of data generated, consumed, copied, and stored is projected to exceed 180 zettabytes by 2025

1,000,000,000,000 GB

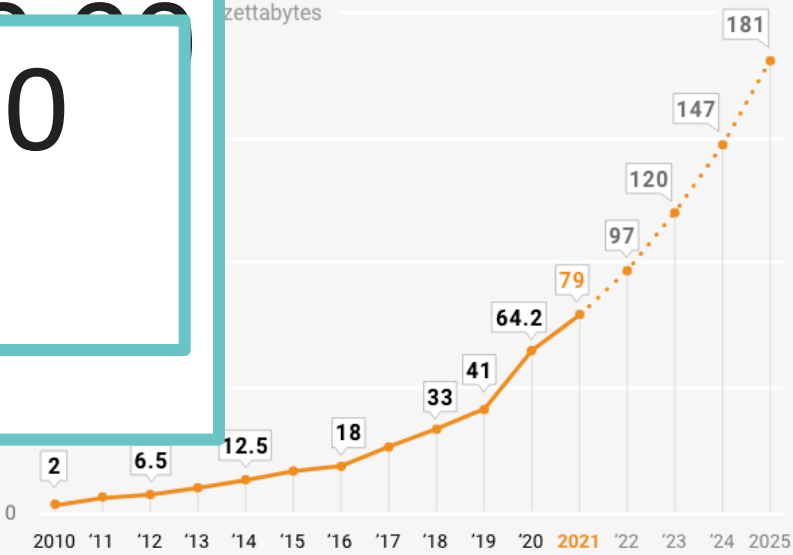
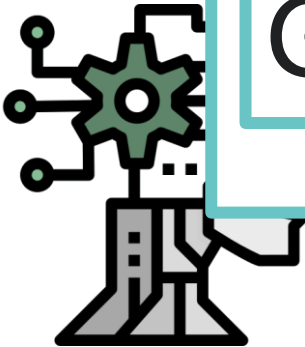
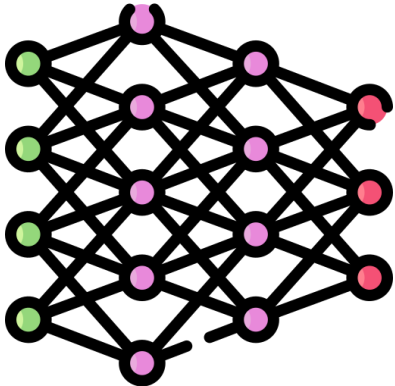

Source: statista.com

firstsiteguide.com



C'est quoi la  
quantique?



# Physique Quantique

## Mécanique classique

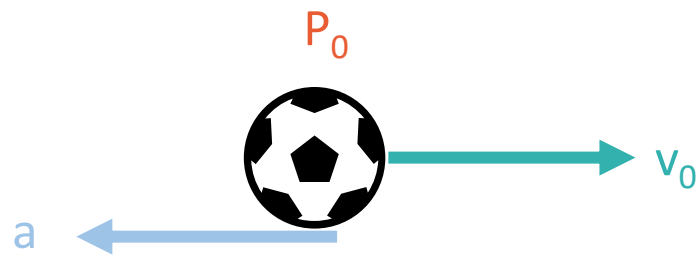

$$v_1 = at + v_0$$
$$p_1 = \frac{1}{2}at^2 + v_0t + p_0$$

## Mécanique Quantique

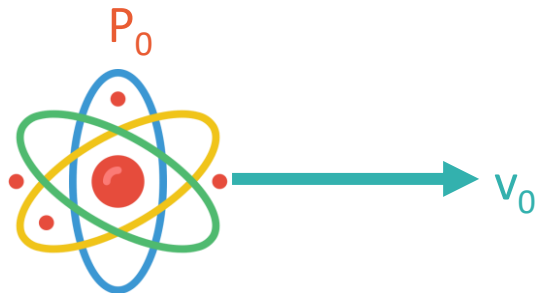

# Physique Quantique



# Physique Quantique

Dualité onde-particule

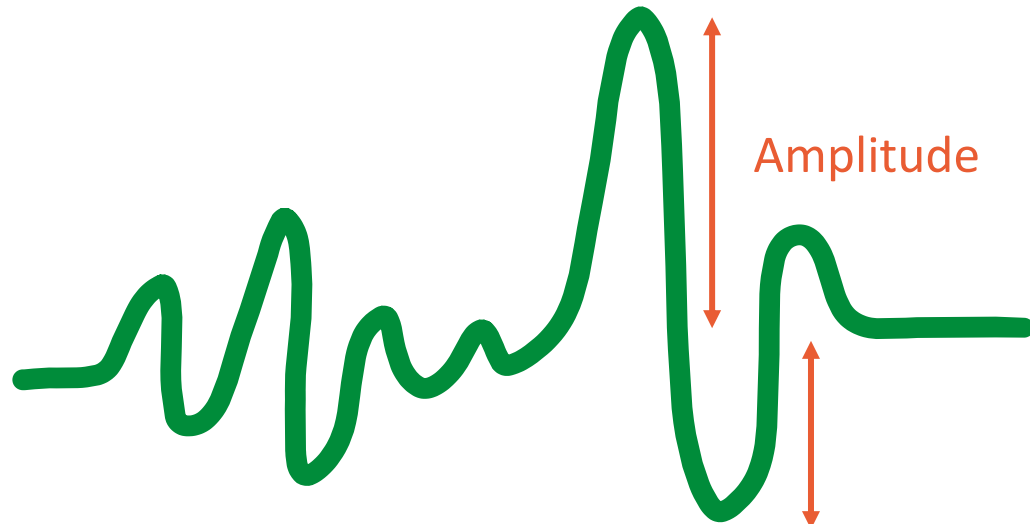
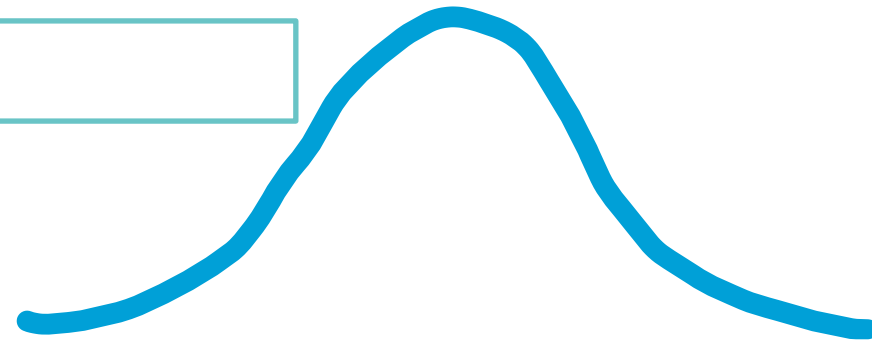
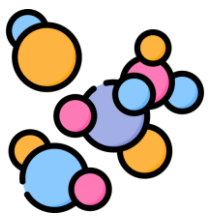

Amplitude

Fonction d'onde

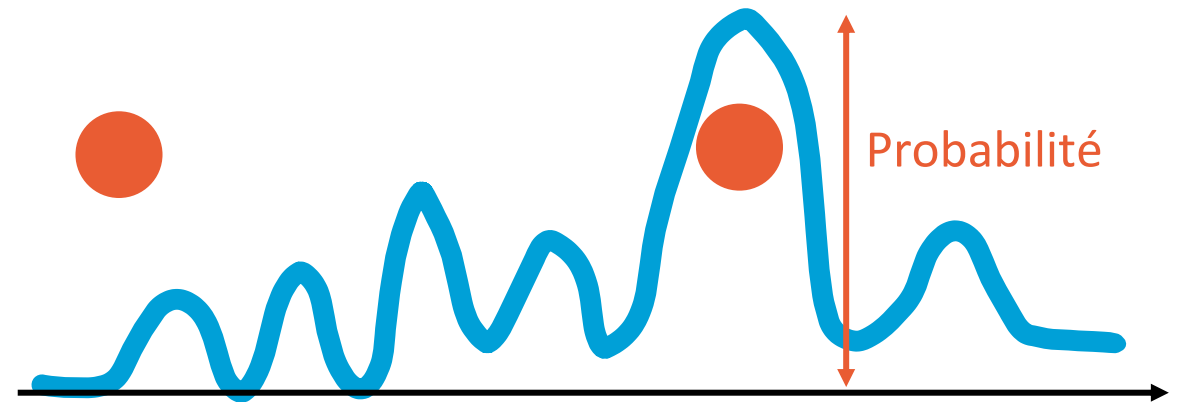

Probabilité

Réduction d'état

# Expérience des fentes de Young



Source des particules

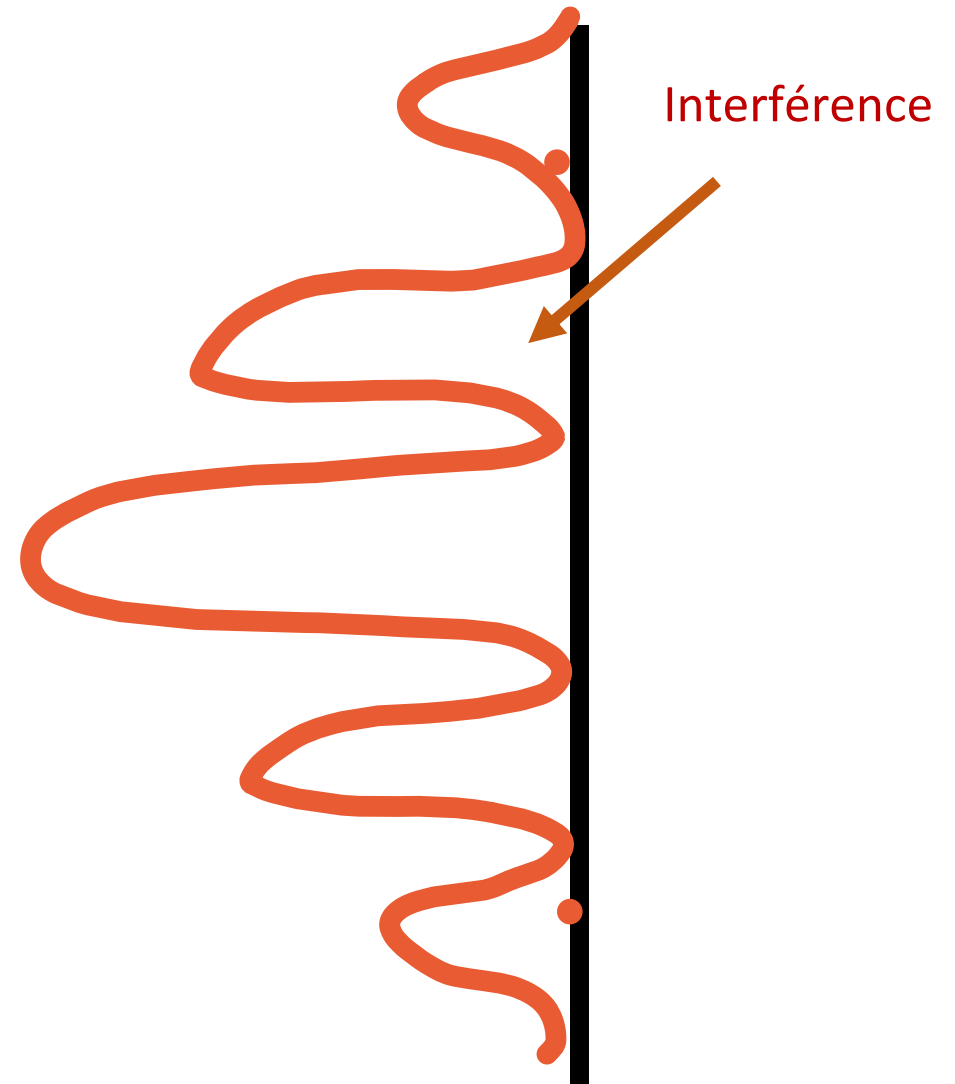
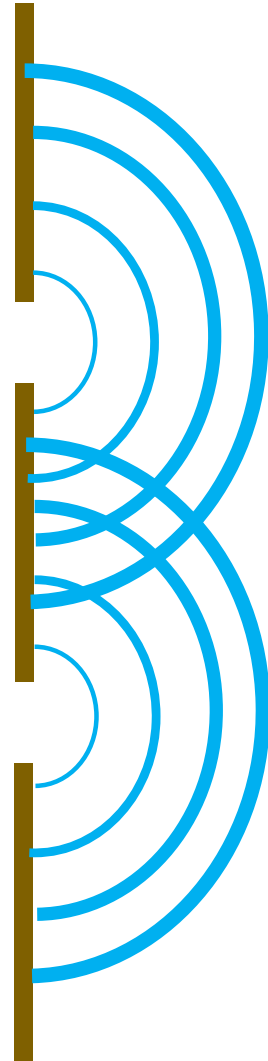

# Superposition

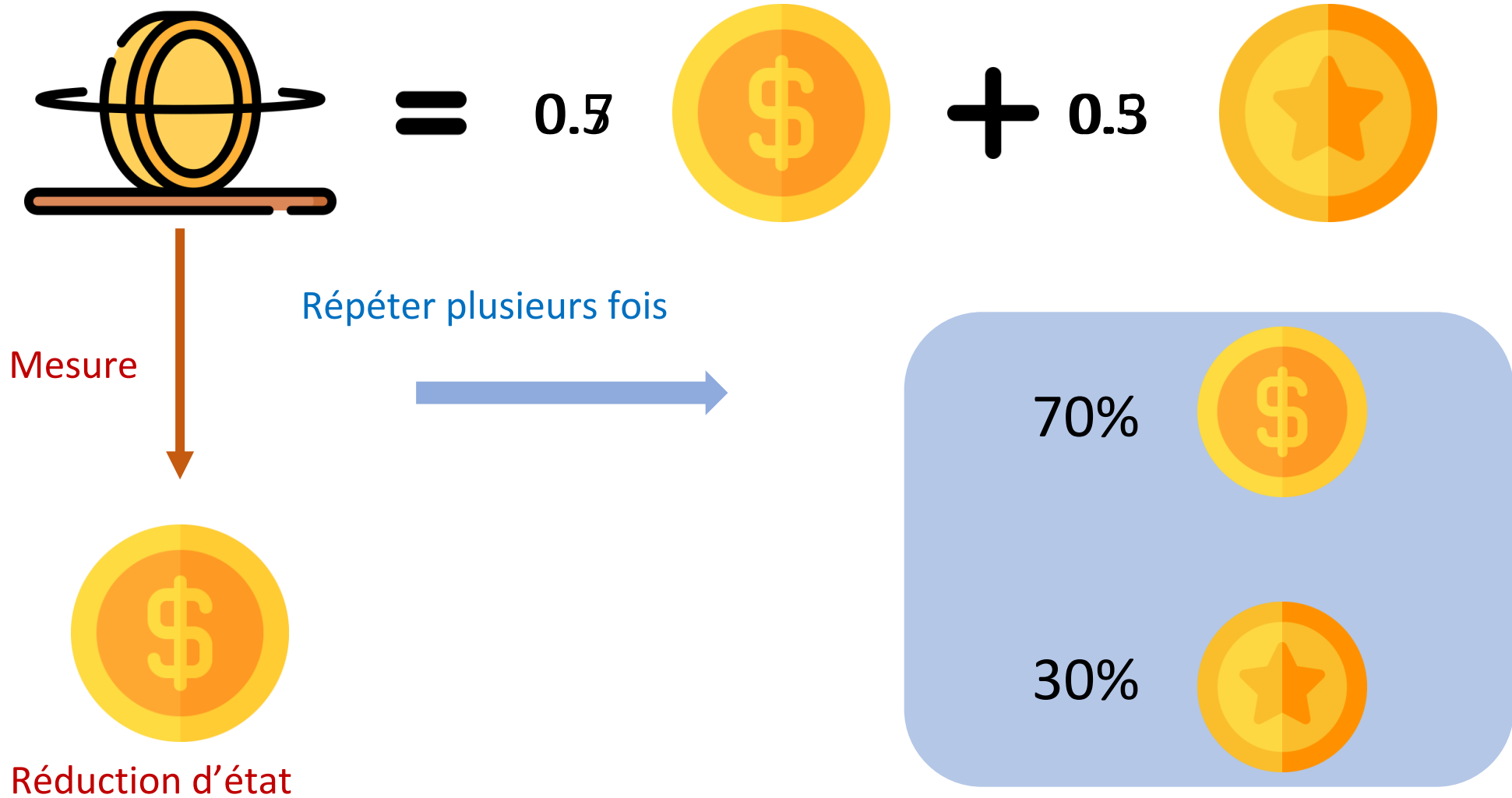



# Intrication

Les balles sont **INTRIQUÉES**.

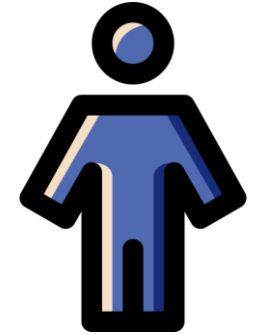
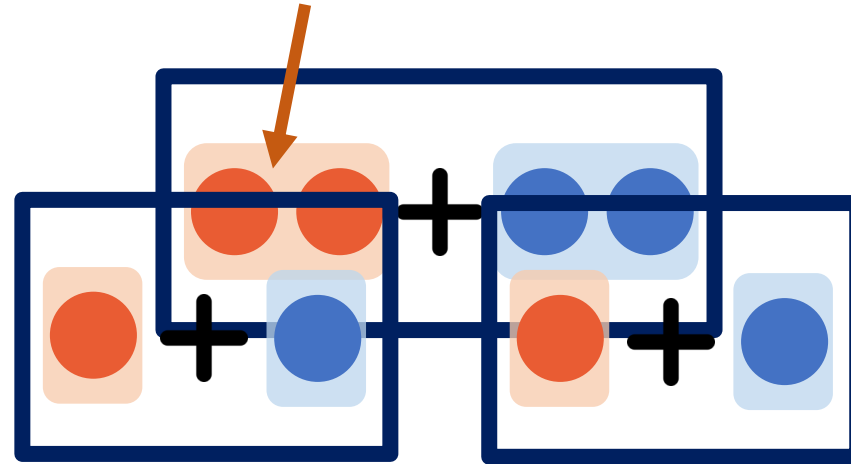
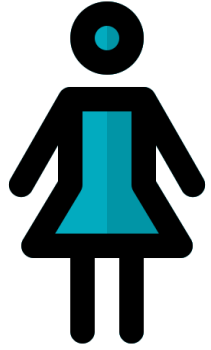

Mesure

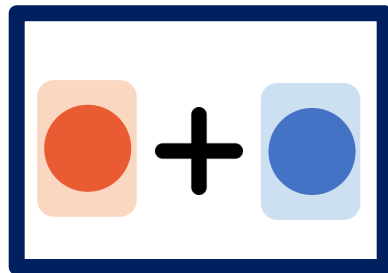
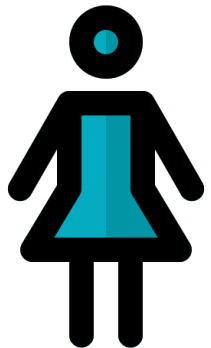

Mesure

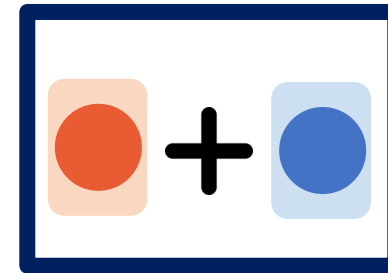

# Intrication

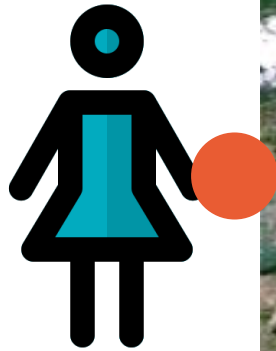



**Comment  
l'ordinateur  
quantique marche?**



# Qubit

## Elements de manipulation de base de l'information

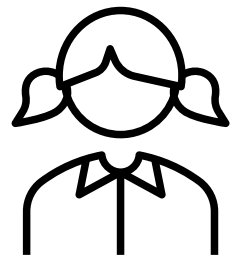

Hello, world!

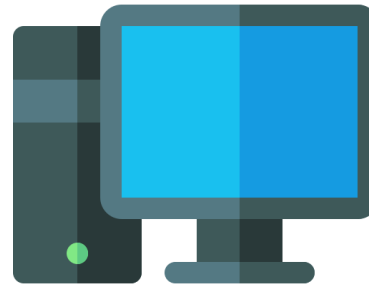

101010101101010101110  
100000010111010101010  
101010010110

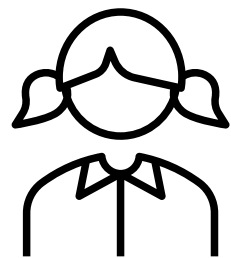

Hello, world!

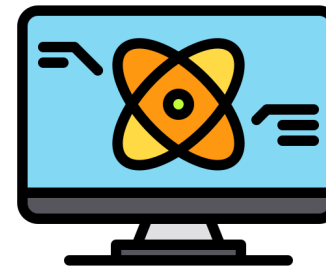
$$\frac{1}{2} |00001\rangle + \frac{1}{2} |10100\rangle \\ + \frac{1}{2} |00111\rangle + \frac{1}{2} |10111\rangle$$

# Qubit

1 qubit

Notation bra-ket

Notation vectorielle

$$|0\rangle = \begin{bmatrix} 1 \\ 0 \end{bmatrix}$$

0  
1

$$|1\rangle = \begin{bmatrix} 0 \\ 1 \end{bmatrix}$$

Etat quantique

Probabilité de mesurer 0:  $|\alpha|^2$

Probabilité de mesurer 1:  $|\beta|^2$

2 qubit

$$|01\rangle = |0\rangle|1\rangle = \begin{bmatrix} 0 \\ 1 \\ 0 \\ 0 \end{bmatrix} \begin{matrix} \leftarrow 00 \\ \leftarrow 01 \\ \leftarrow 10 \\ \leftarrow 11 \end{matrix}$$

Amplitude

$$|\psi\rangle = \alpha|0\rangle + \beta|1\rangle = \begin{bmatrix} \alpha \\ \beta \end{bmatrix}$$

$$\alpha = r_0 e^{i\theta_0}, \beta = r_1 e^{i\theta_1}$$

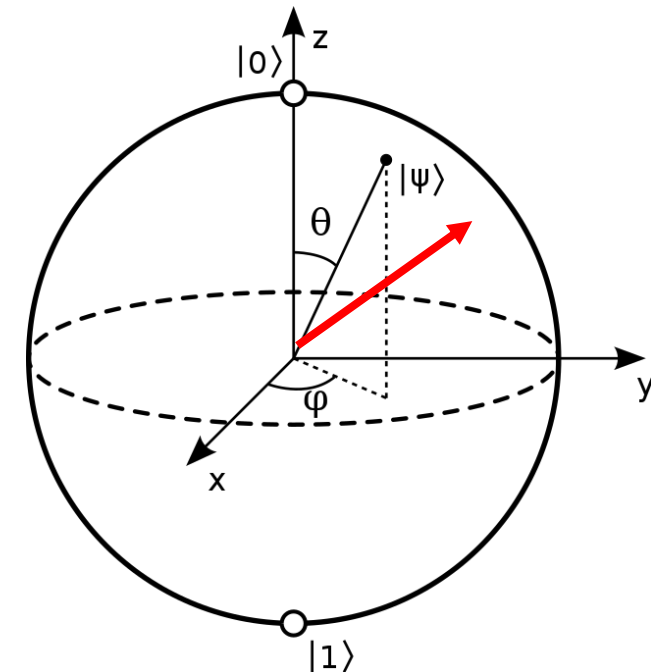

# Portes quantiques

## Portes classiques

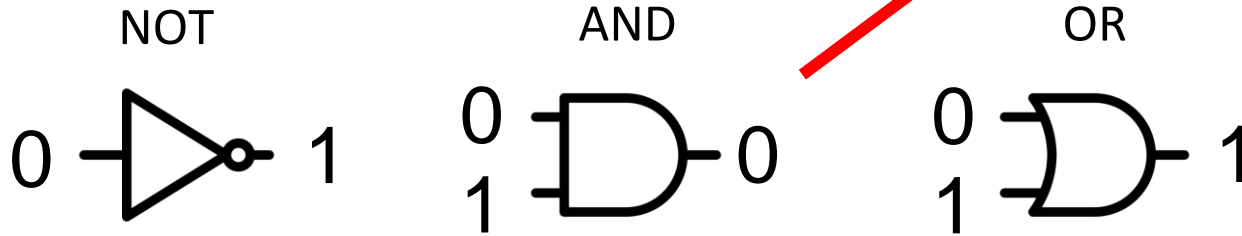

Sur bits

## Portes quantiques

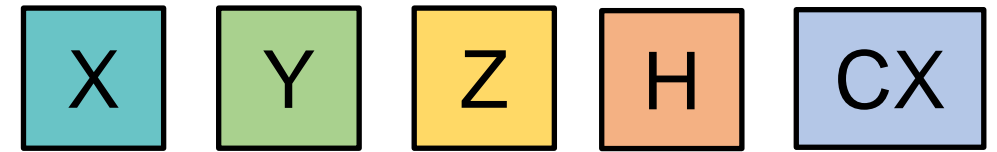

Sur qubits

## Notation matricielle:

$$\boxed{X} = \begin{bmatrix} 0 & 1 \\ 1 & 0 \end{bmatrix}$$

$$\boxed{Z} = \begin{bmatrix} 1 & 0 \\ 0 & -1 \end{bmatrix}$$

$$\boxed{Y} = \begin{bmatrix} 0 & -i \\ i & 0 \end{bmatrix}$$

$$\boxed{H} = \frac{1}{\sqrt{2}} \begin{bmatrix} 1 & 1 \\ 1 & -1 \end{bmatrix}$$

# Portes quantiques

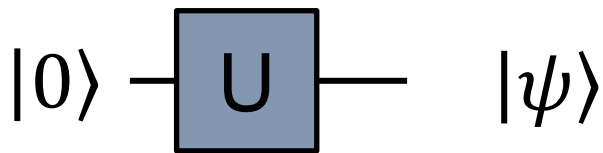
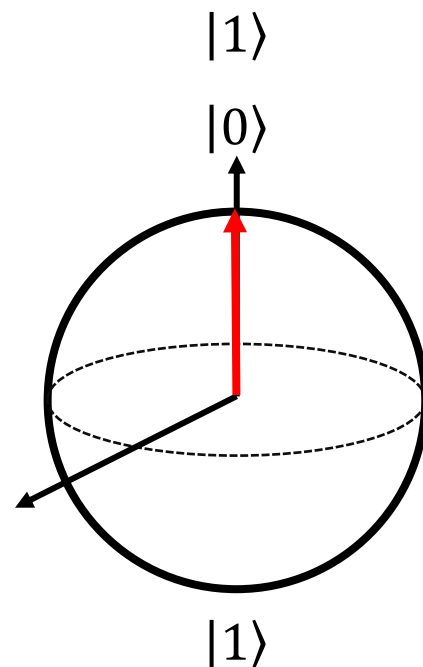
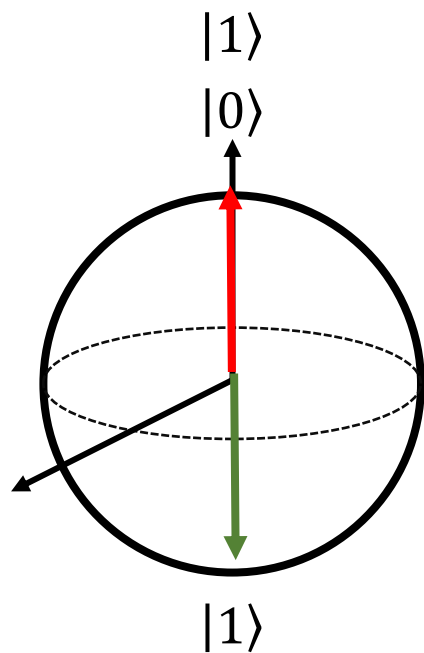
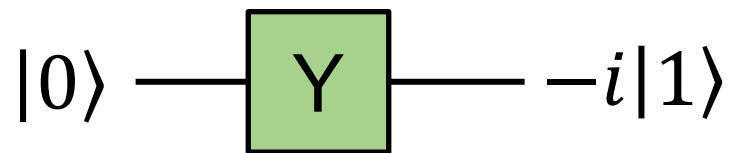
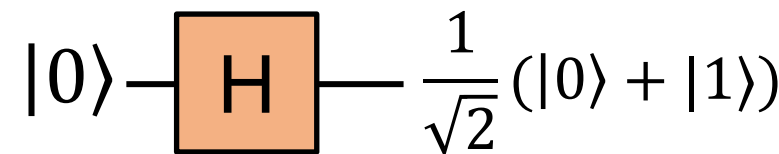
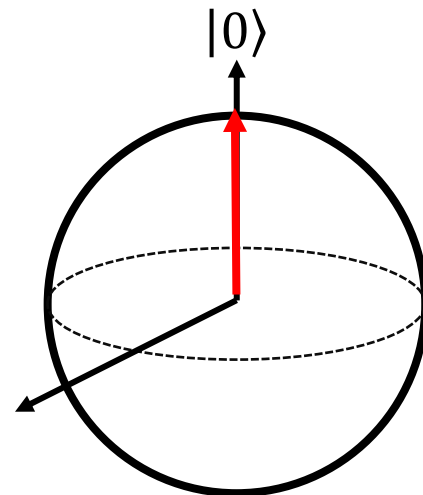
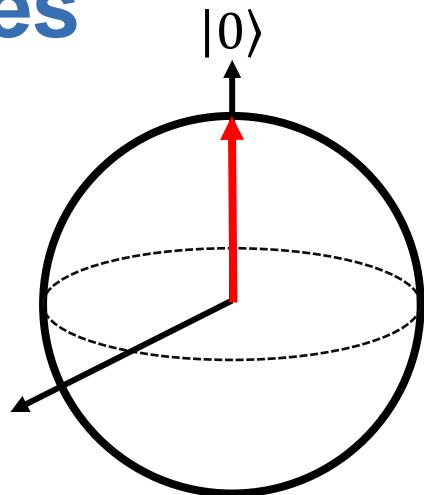
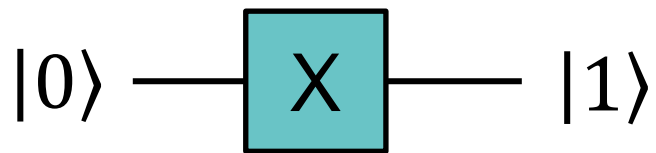

# Porte CNOT

Créer un état intriqué!

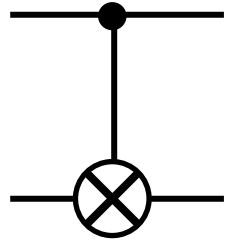

$$\begin{aligned} CX|00\rangle &= |00\rangle, & CX|01\rangle &= |01\rangle \\ CX|10\rangle &= |11\rangle, & CX|11\rangle &= |10\rangle \end{aligned}$$

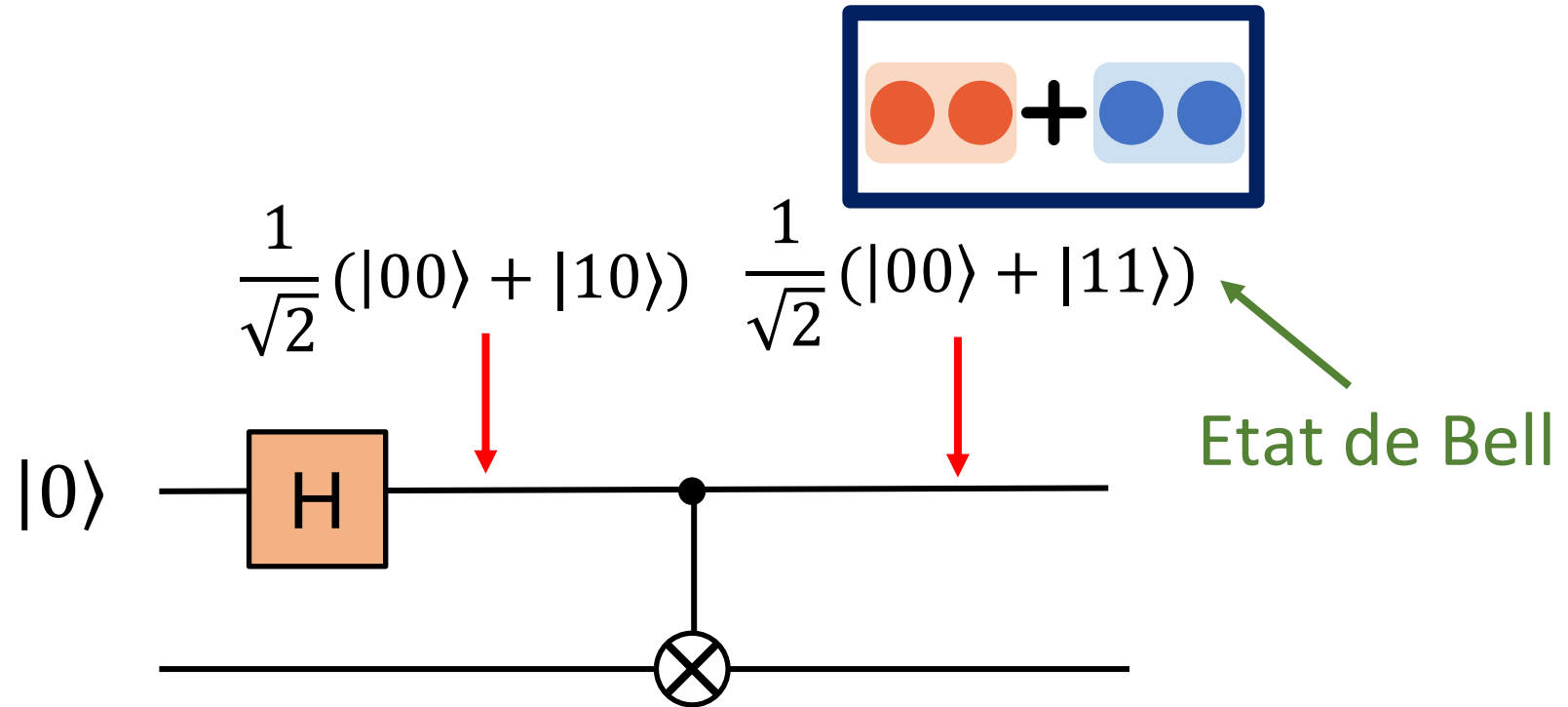



# Circuit quantique

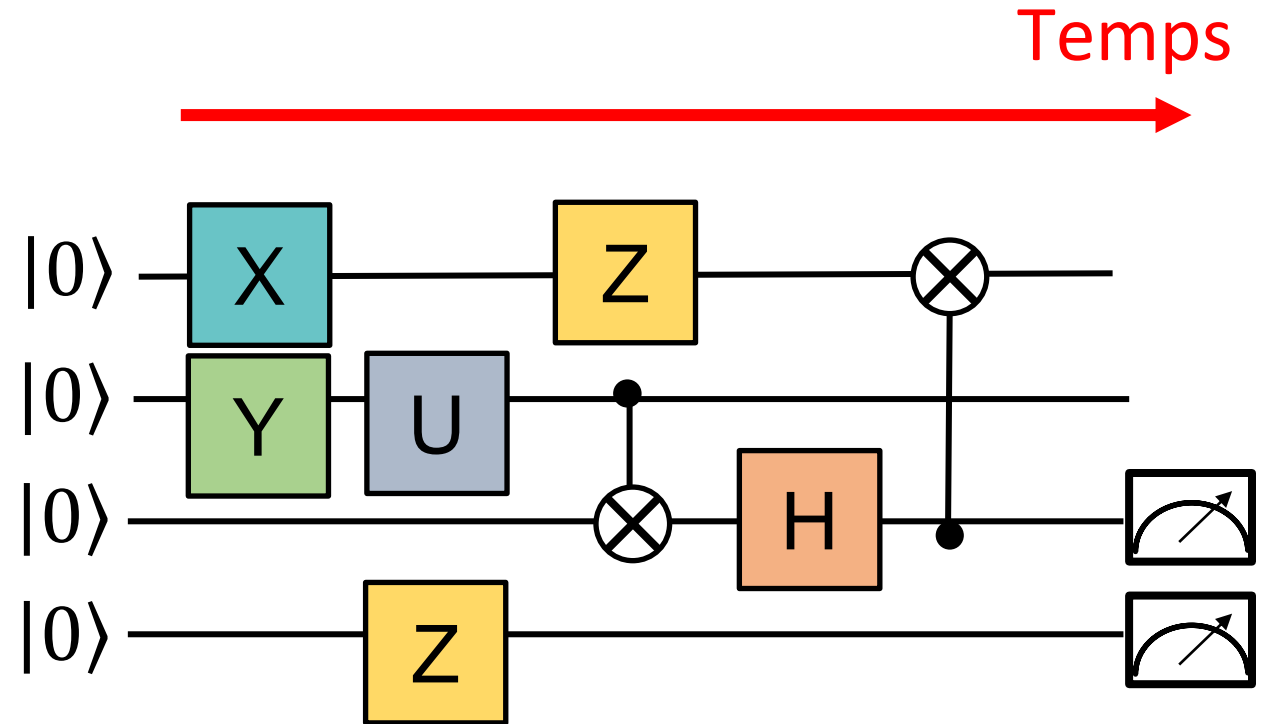
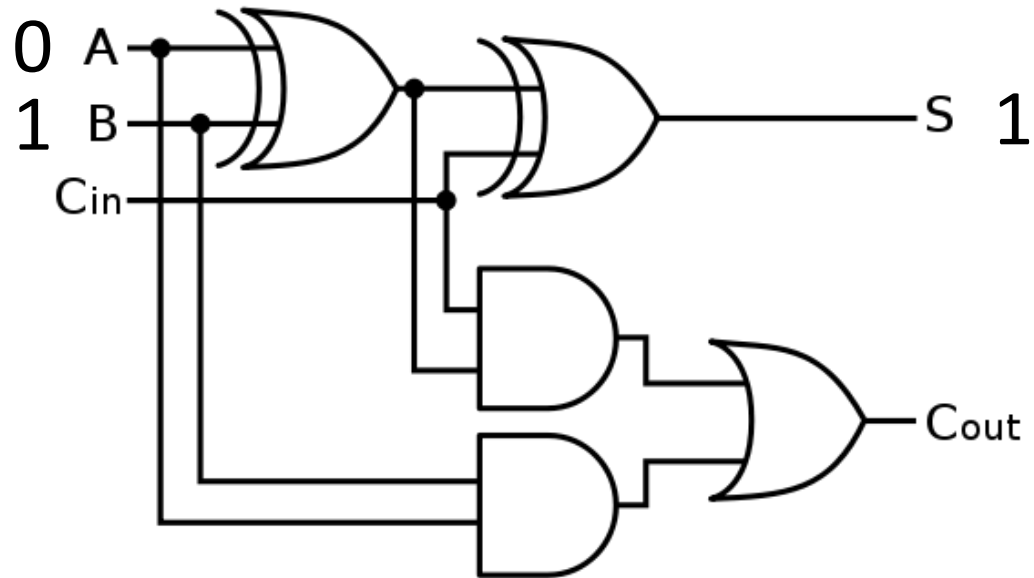

00  $\rightarrow$  30%  
01  $\rightarrow$  20%  
10  $\rightarrow$  45%  
11  $\rightarrow$  5%

# Ordinateurs Quantiques

<https://www.nature.com/articles/d41586-021-03476-5>

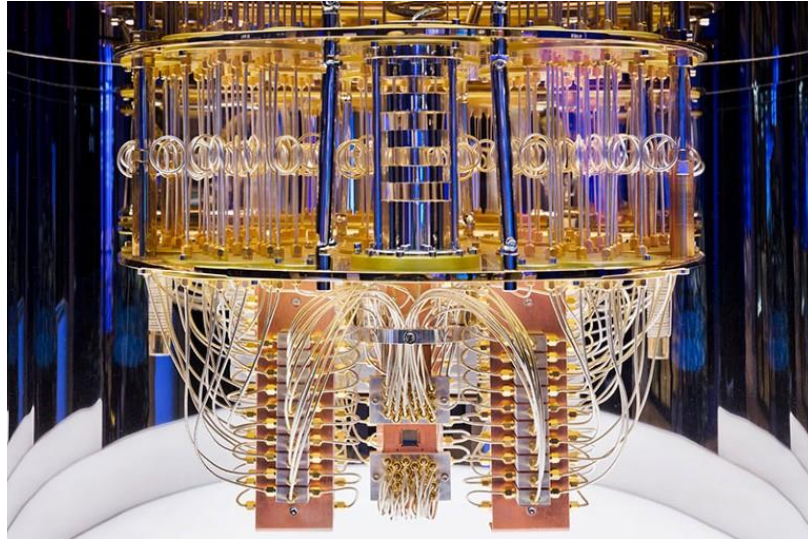

<https://phys.org/news/2020-07-ion-technology-quantum.html>

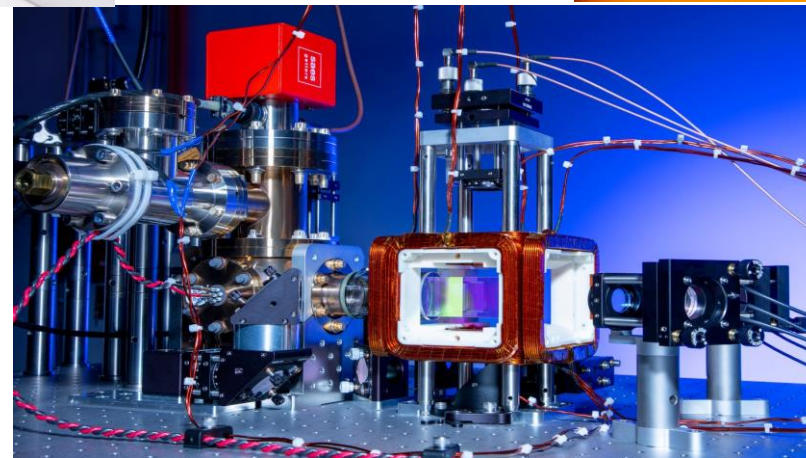
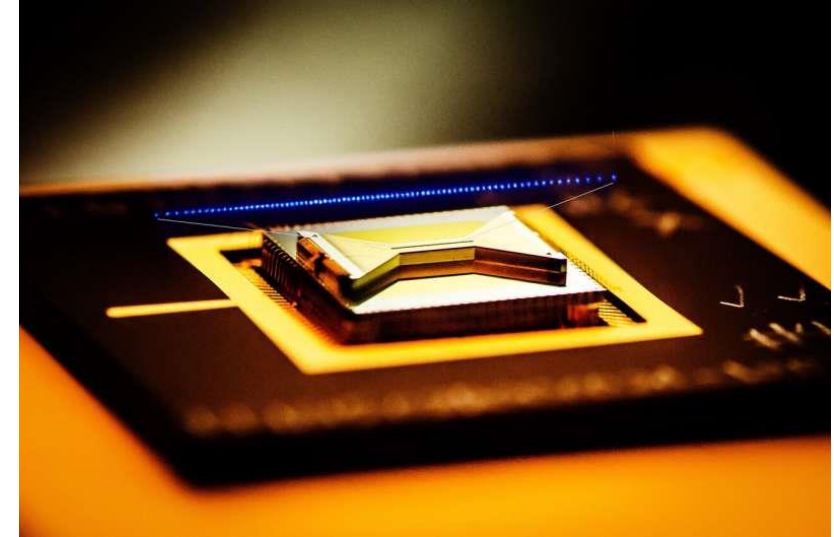

<https://www.popsci.com/technology/neutral-atom-quantum-computer/>

# Comment utiliser l'ordinateur quantique?



Qiskit



Microsoft



SILQ



Cirq

PENNY  
LANE

High-Level Quantum Programming

<https://quantum-computing.ibm.com/>

# Pourquoi l'ordinateur quantique?

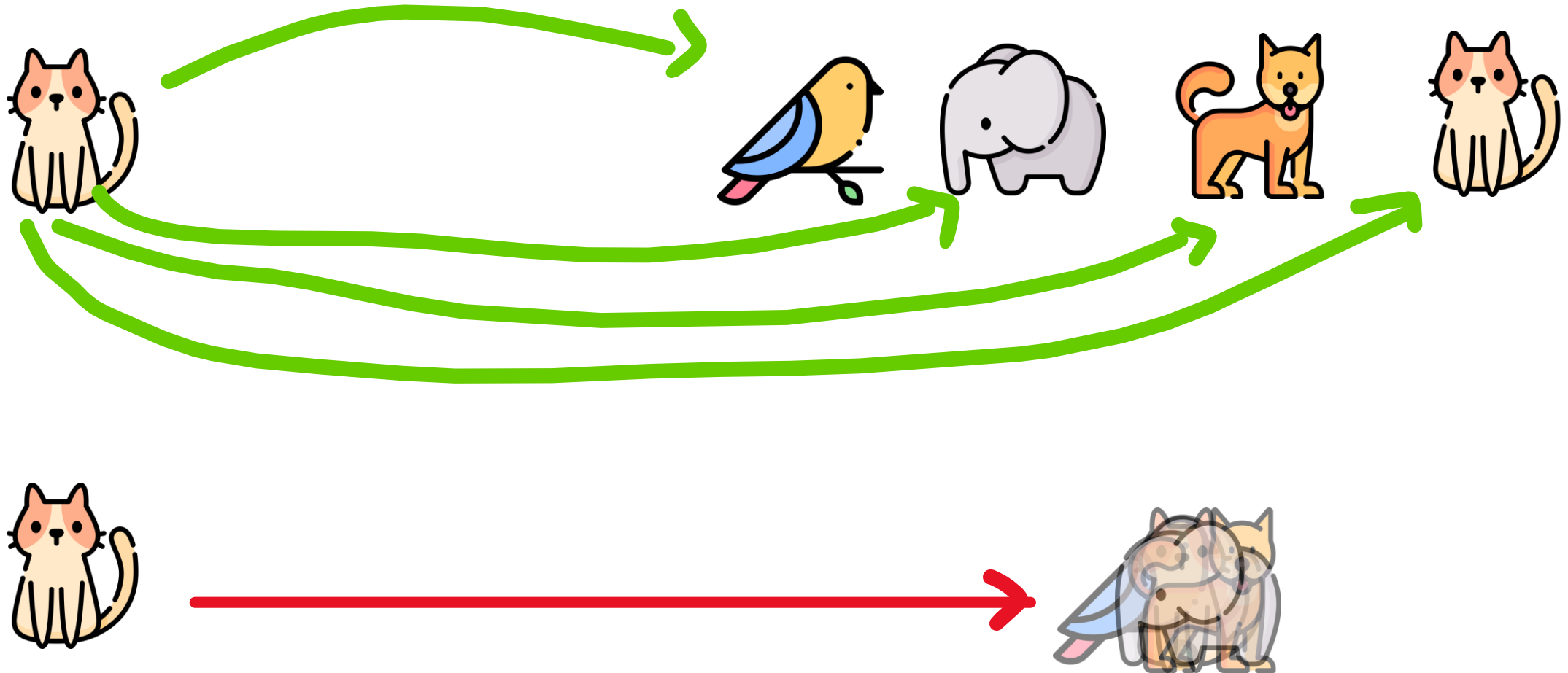

# Avantage quantique



<https://slideplayer.com/slide/3169508/>  
Time Complexity Revisited

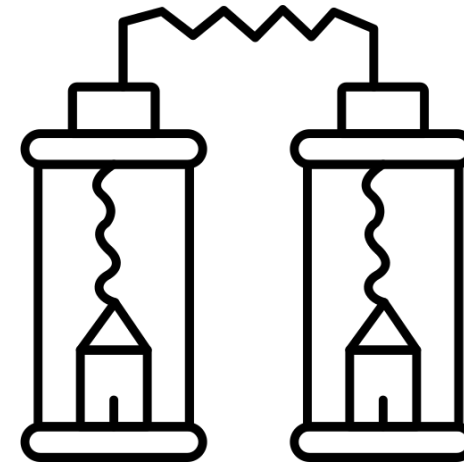
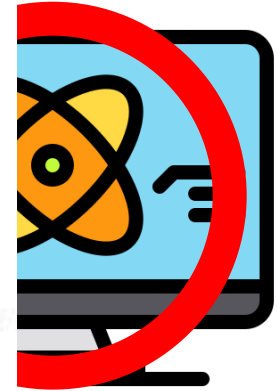
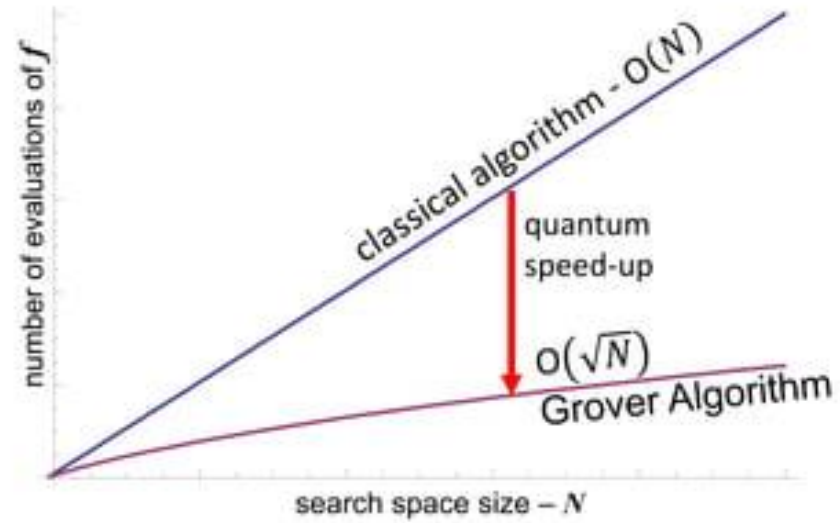

# Avantage quantique

nature

Explore content ▾ Journal information ▾ Publish with us ▾ Subscribe

nature > news > article

NEWS | 03 December 2020

## Physicists in China challenge Google's 'quantum advantage'

Photon-based quantum computer does a calculation that ordinary computers might never be able to do.

Philip Ball

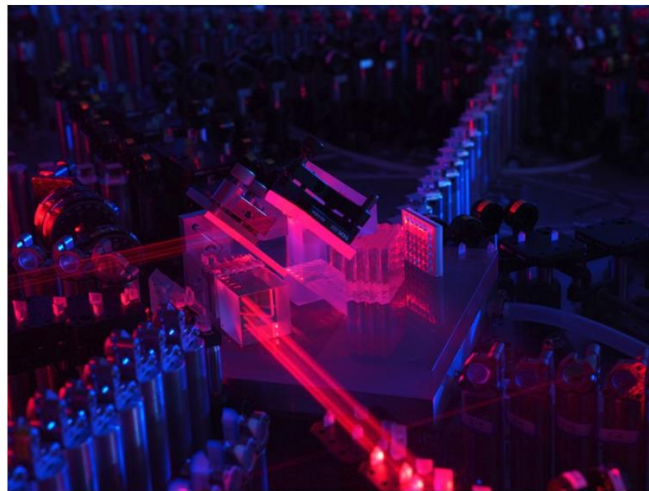

This photonic computer performed in 200 seconds a calculation that on an ordinary supercomputer would take 2.5 billion years to complete. Credit: Hansen Zhong



# Pourquoi pas encore??

Erreurs de calculs

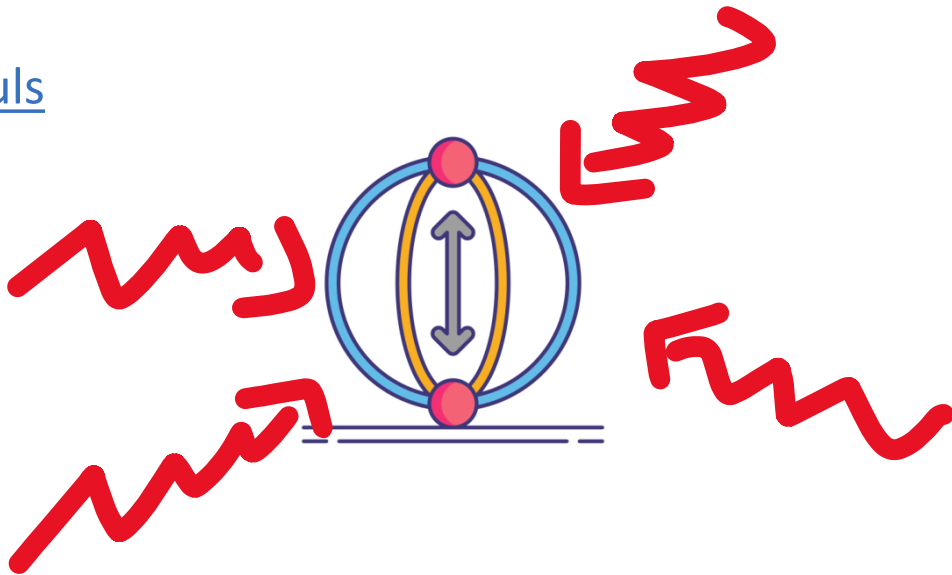

Aujourd'hui

100-1000 X



On a besoin.....

100000000 X



MESURE  
 $|0\rangle$

Théorie

$0 \rightarrow 100\%$



$1 \rightarrow 0\%$

Réalité



$0 \rightarrow 90\%$

$1 \rightarrow 10\%$

# Development Roadmap

Executed by IBM   
On target 

IBM Quantum

2019 	2020 	2021 	2022	2023	2024	2025	Beyond 2026
Run quantum circuits on the IBM cloud	Demonstrate and prototype quantum algorithms and applications	Run quantum programs 100x faster with Qiskit Runtime	Bring dynamic circuits to Qiskit Runtime to unlock more computations	Enhancing applications with elastic computing and parallelization of Qiskit Runtime	Improve accuracy of Qiskit Runtime with scalable error mitigation	Scale quantum applications with circuit knitting toolbox controlling Qiskit Runtime	Increase accuracy and speed of quantum workflows with integration of error correction into Qiskit Runtime

Model Developers

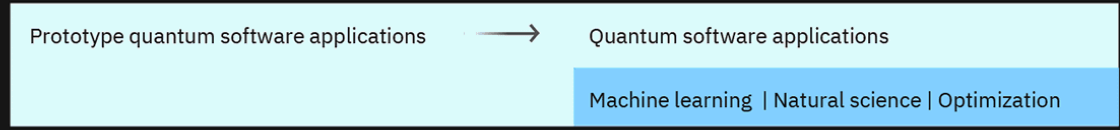

Algorithm Developers

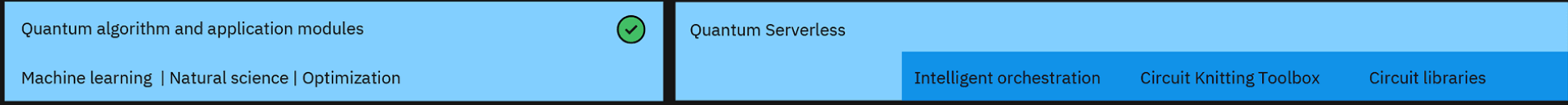

Kernel Developers

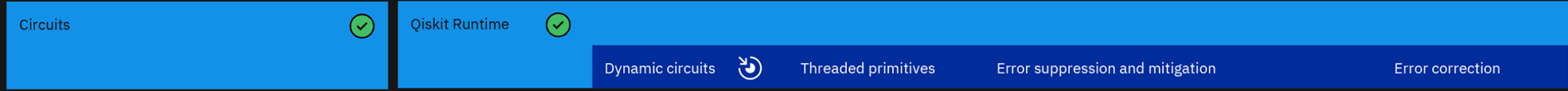

System Modularity

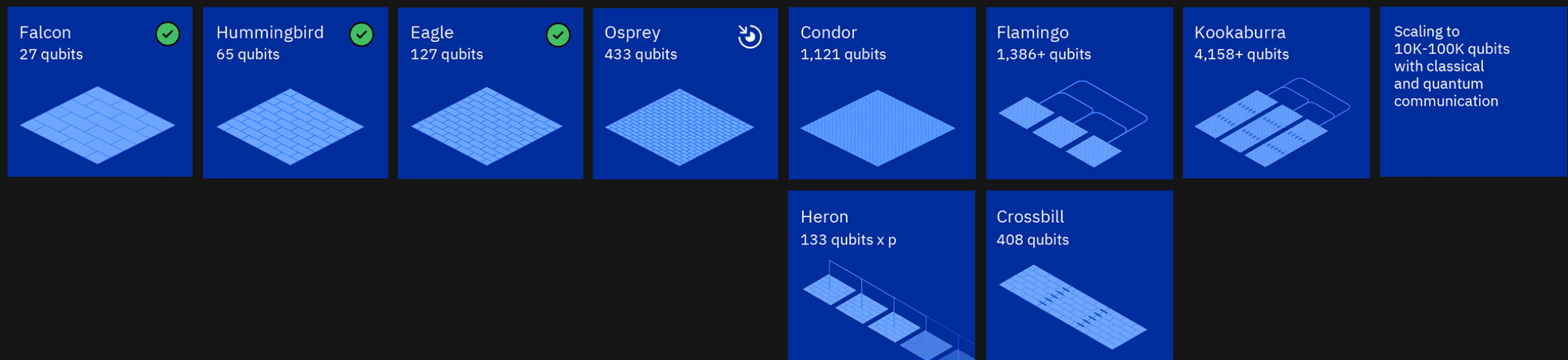



# Conclusion

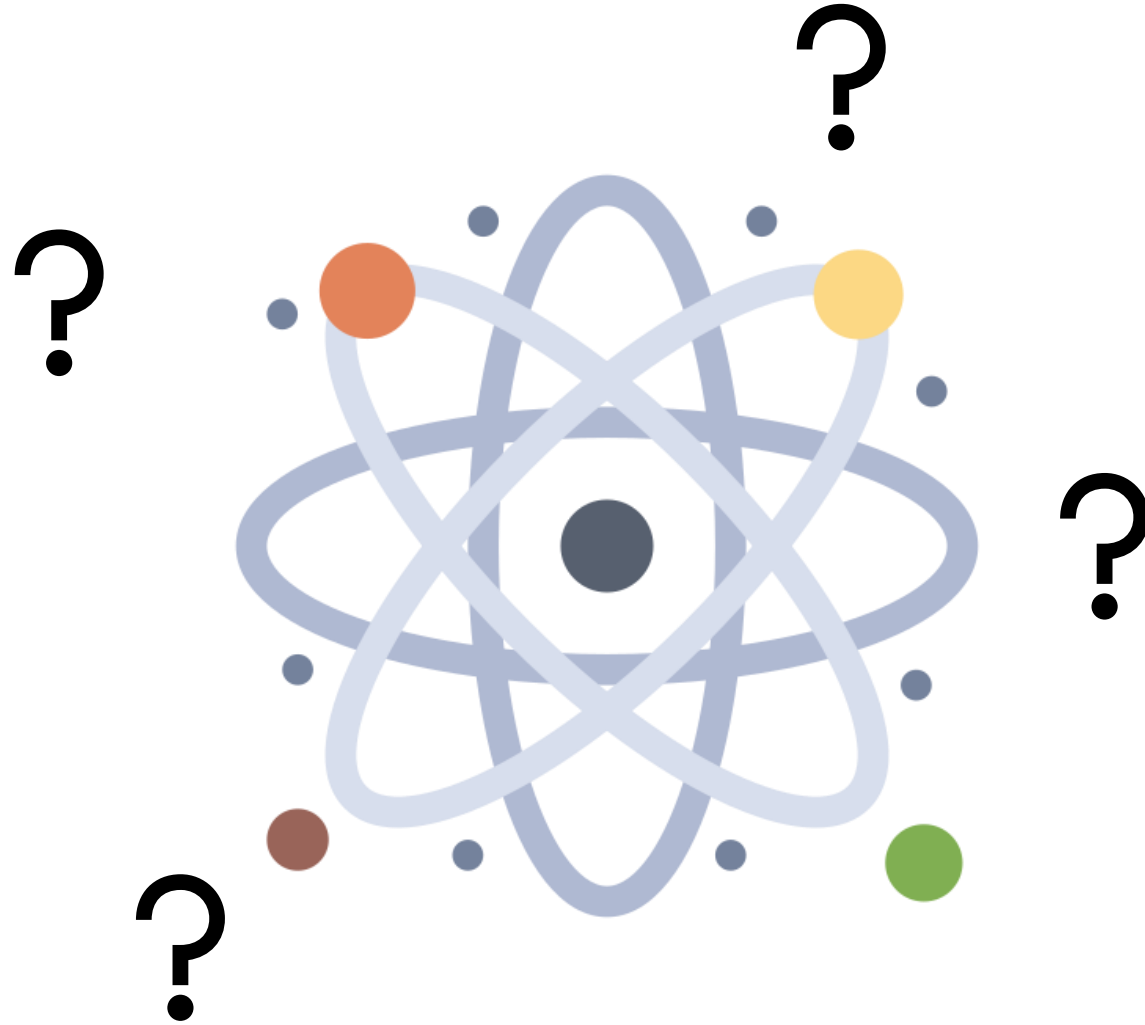

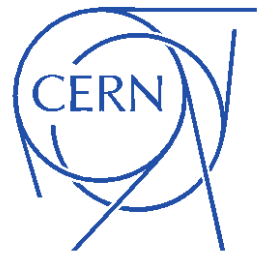

**QUANTUM  
TECHNOLOGY  
INITIATIVE**