



Understanding the first observation of $B \rightarrow K\nu\bar{\nu}$ by Belle-II

Olcyr Sumensari

IJCLab (Orsay)

Based on [2301.06990, 2309.02246],
in collaboration with L. Allwicher, D. Becirevic, G. Piazza and S. Rosauro-Alcaraz

ICHEP '24, 19 July, 2024



Motivation

- Flavor Changing Neutral Current (FCNC) processes are powerful indirect probes of New Physics (NP) effects since they are loop- and CKM suppressed.

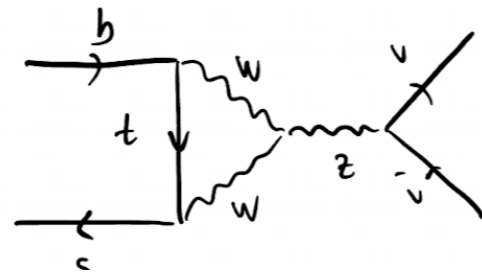
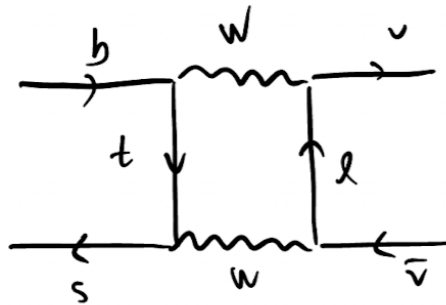

...

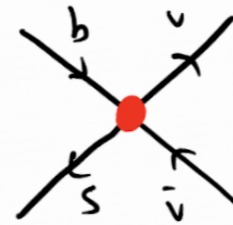

$$O_{\text{exp}} = O_{\text{SM}} \left(1 + \# \frac{C}{\Lambda^2} + \dots \right)$$

$\propto \frac{|V_{tb}V_{ts}^*|^2}{(16\pi^2)^2}$

- The **main obstacle** to probe NP at **low energies** is the careful assessment of **hadronic uncertainties**:
 - \Rightarrow Decays based on the $b \rightarrow s\nu\bar{\nu}$ transition are **theoretically cleaner** than those based on $b \rightarrow s\ell\bar{\ell}$, since they are **not affected** by **problematic** long-distance contributions from $c\bar{c}$ loops.

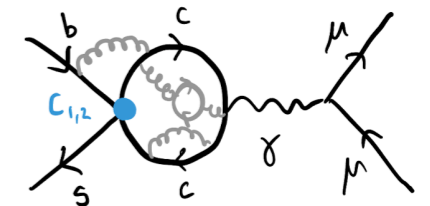

- Motivation** to study these decays:

\Rightarrow **Progress** in the **lattice QCD** determinations of the $B \rightarrow K$ form-factor [HPQCD, 2207.12468].

\Rightarrow **First observation** of $B \rightarrow K\nu\bar{\nu}$ by **Belle-II** [Belle-II, 2311.1467].

This talk:

- i. Revisit the SM predictions for $B \rightarrow K^{(*)}\nu\bar{\nu}$.
- ii. What can we learn from these measurements (in the SM and beyond)?

$B \rightarrow K \nu \bar{\nu}$ in the SM

- **Effective Hamiltonian** in the SM:

see e.g. [Buras et al. '14]

$$\mathcal{L}_{\text{eff}}^{b \rightarrow s \nu \nu} = \frac{4G_F \lambda_t}{\sqrt{2}} \frac{\alpha_{\text{em}}}{2\pi} \sum_i C_L^{\text{SM}} (\bar{s}_L \gamma_\mu b_L) (\bar{\nu}_{Li} \gamma^\mu \nu_{Li}) + \text{h.c.},$$

$$\lambda_t = V_{tb} V_{ts}^*$$

- **Short-distance** contributions known to **good precision**:

$$C_L^{\text{SM}} = -X_t / \sin^2 \theta_W$$

$$= -6.32(7)$$

Including NLO QCD and two-loop EW contributions:

$$X_t = 1.462(17)(2)$$

[Buchala et al. '93, '99], [Misiak et al. '99], [Brod et al. '10]

Two main sources of uncertainties:

i) Hadronic matrix-element:

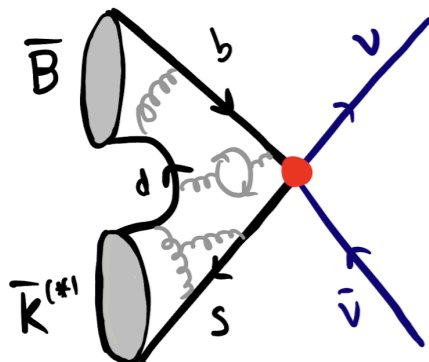

$$\langle K^{(*)} | \bar{s}_L \gamma^\mu b_L | B \rangle = \sum_a \overset{\text{Known Lorentz factors}}{\downarrow} K_a^\mu \mathcal{F}_a(q^2)$$

Form-factors (e.g., LQCD) \uparrow

ii) CKM matrix:

From CKM unitarity:

$$|V_{tb} V_{ts}^*| = |V_{cb}| (1 + \mathcal{O}(\lambda^2))$$

Which value to take (incl. vs. excl.)?

I. Form-factors: $B \rightarrow K\nu\bar{\nu}$

See talk by Witzel

- Lattice QCD data available at **nonzero recoil** ($q^2 \neq q_{\max}^2$) for all form-factors:

$$\langle K(k) | \bar{s}_L \gamma^\mu b_L | B(p) \rangle = \left[(p+k)^\mu - \frac{m_B^2 - m_K^2}{q^2} q^\mu \right] f_+(q^2) + q^\mu \frac{m_B^2 - m_K^2}{q^2} f_0(q^2)$$

with $f_+(0) = f_0(0)$.

Only form-factor needed for $B \rightarrow K\nu\bar{\nu}$!

- **[NEW]** We update the FLAG average by combining [HPQCD '22] results with [FNAL/MILC '16]:

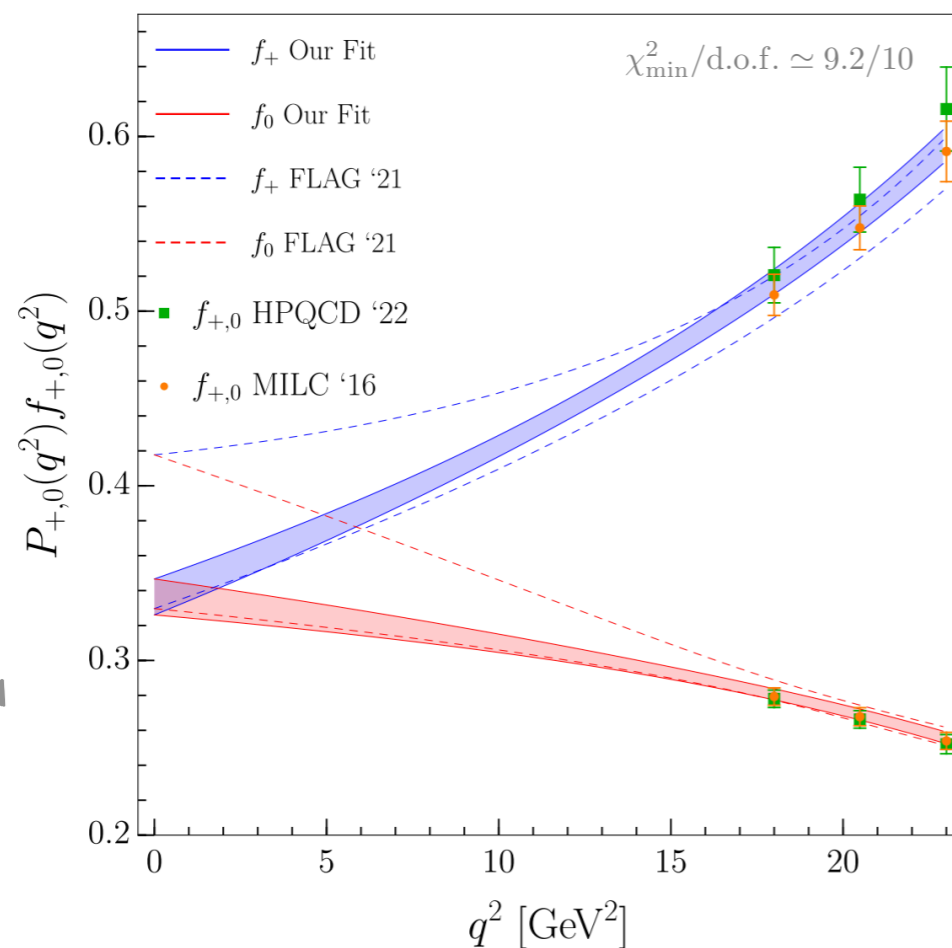

Pole factor:

$$P_i(q^2) = 1 - q^2/M_i^2$$

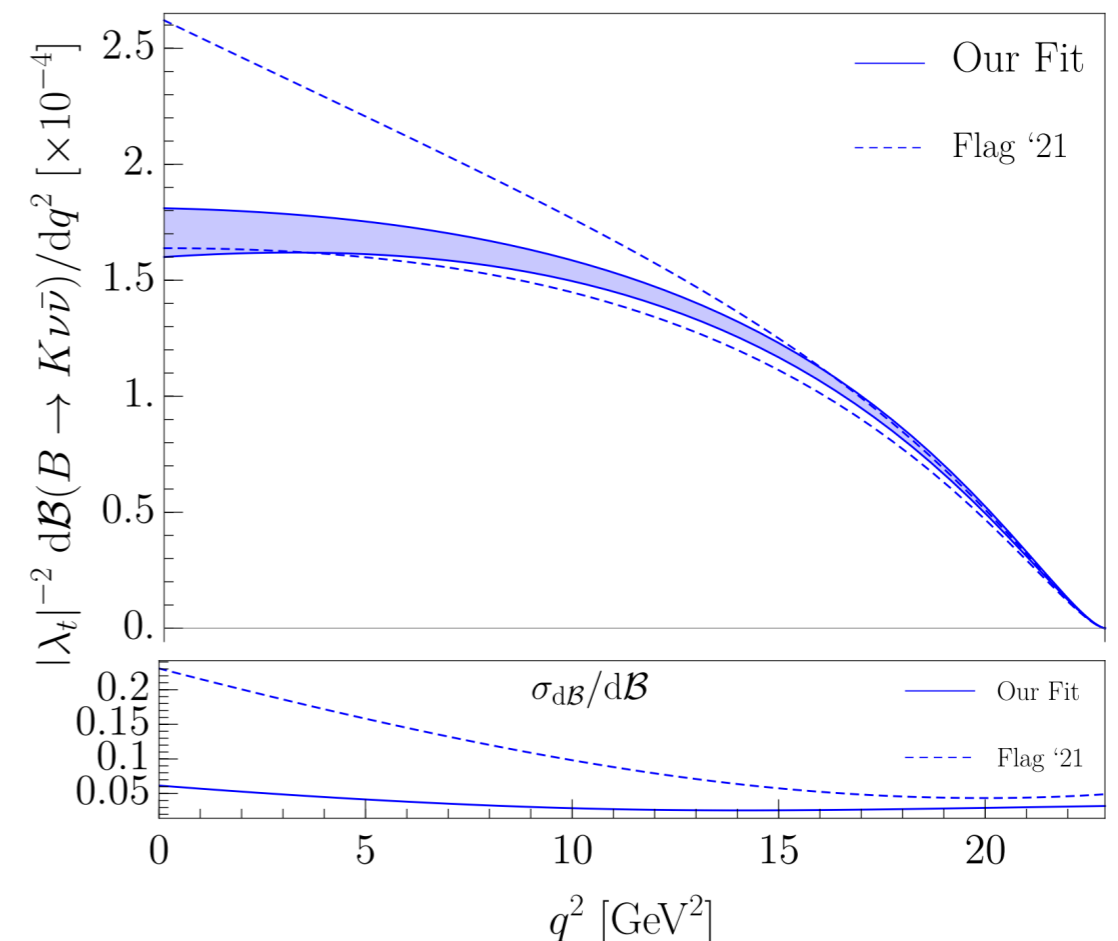

[Becirevic, Piazza, OS. 2301.06990]

I. Form-factors: $B \rightarrow K\nu\bar{\nu}$

**Annihilation contributions not included below (see back-up)*

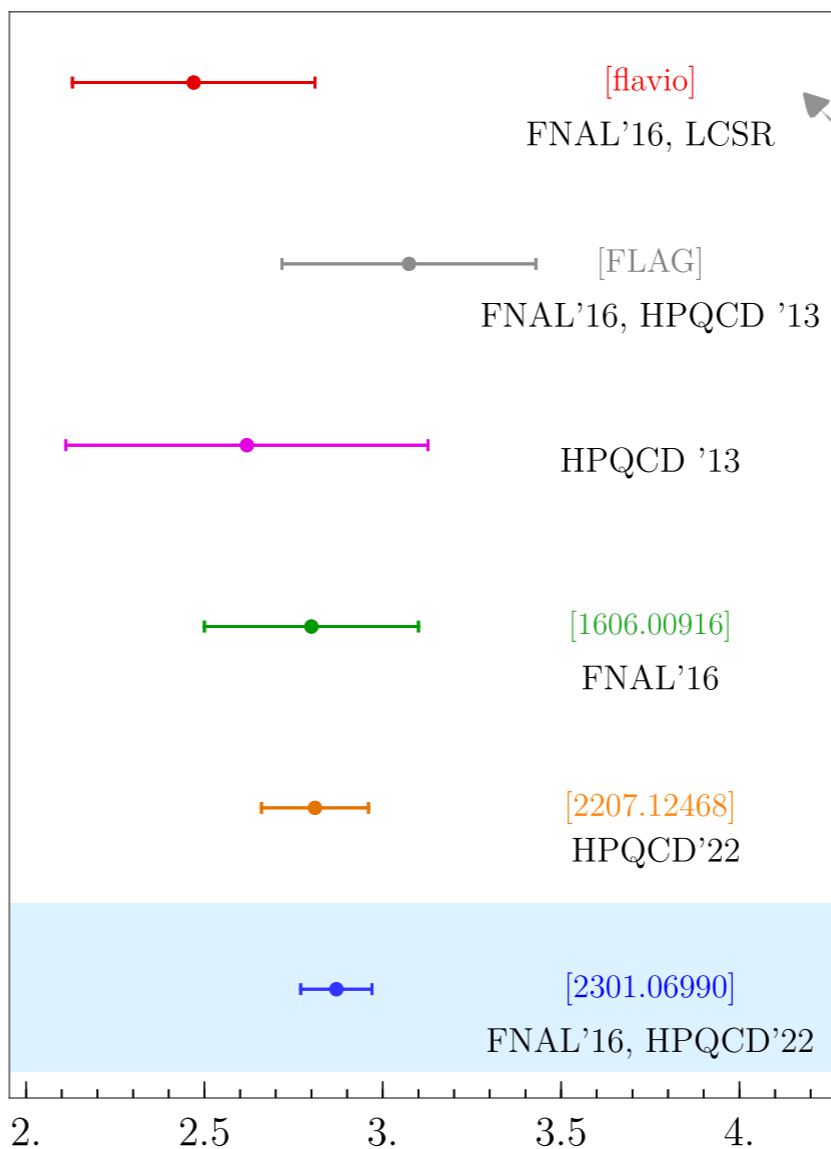

Form-factors based on Light-Cone Sum Rules (LCSR) lead to smaller branching fractions.

[Bharucha et al. '15, Gubernari et al. '18]

$$\mathcal{B}(B^+ \rightarrow K^+ \nu \bar{\nu})_{\text{loop}}^{\text{SM}} / |\lambda_t|^2$$

$$\mathcal{B}(B \rightarrow K\nu\bar{\nu})^{\text{SM}} / |\lambda_t|^2 = \begin{cases} (1.33 \pm 0.04)_{K_S} \times 10^{-3} \\ (2.87 \pm 0.10)_{K^+} \times 10^{-3} \end{cases} \quad [\approx 3\% \text{ uncertainty}]$$

[Becirevic, Piazza, OS. 2301.06990]

[Intermezzo]: Cross-check of $f_+^{B \rightarrow K}(q^2)$

- SM predictions depend on the **extrapolation** of the LQCD **form factors to low q^2** values — **parameterisation dependent?**

⇒ How can we **test the shape** of the **extrapolated LQCD form-factors**?

- We propose to measure:

[Becirevic, Piazza, **OS**. 2301.06990]

$$r_{\text{low/high}} = \frac{\mathcal{B}(B \rightarrow K \nu \bar{\nu})_{\text{low-}q^2}}{\mathcal{B}(B \rightarrow K \nu \bar{\nu})_{\text{high-}q^2}}$$

⇒ Independent of λ_t and the *form-factor normalisation*, as well as of *NP contributions*.

NB. w/o ν_R

- Using the bins $(0, q_{\text{max}}^2/2)$ vs. $(q_{\text{max}}^2/2, q_{\text{max}}^2)$:

e.g, using (old) FLAG average:

$$r_{\text{low/high}} = 1.91 \pm 0.06$$

$$r_{\text{low/high}} = 2.15 \pm 0.26$$

Binned measurements at Belle-II would be a **useful cross-check** of the **consistency** of the q^2 -**shape** of **SM predictions**.

I. Form-factors: $B \rightarrow K^* \nu \bar{\nu}$

- $B \rightarrow K^* \nu \bar{\nu}$ decays are **more challenging** for several reasons:

$$\begin{aligned} \langle \bar{K}^*(k) | \bar{s} \gamma_\mu (1 - \gamma_5) b | \bar{B}(p) \rangle = & \varepsilon_{\mu\nu\rho\sigma} \varepsilon^{*\nu} p^\rho k^\sigma \frac{2V(q^2)}{m_B + m_{K^*}} \\ & - i\varepsilon_\mu^* (m_B + m_{K^*}) A_1(q^2) \\ & + i(p+k)_\mu (\varepsilon^* \cdot q) \frac{A_2(q^2)}{m_B + m_{K^*}} \\ & + iq_\mu (\varepsilon^* \cdot q) \frac{2m_{K^*}}{q^2} [A_3(q^2) - A_0(q^2)] , \end{aligned}$$

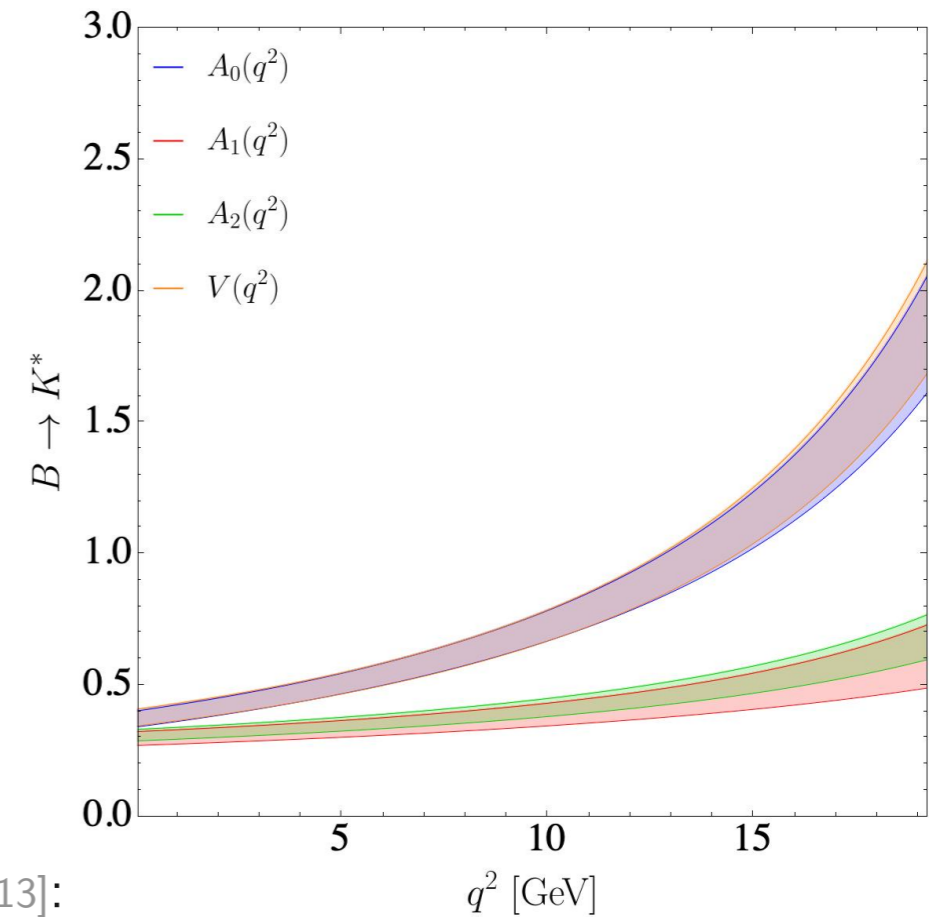

- We use LCSR (+LQCD) results from [Bharucha et al. '15, Horgan et al. '13]:

$$\mathcal{B}(B \rightarrow K^* \nu \bar{\nu})^{\text{SM}} / |\lambda_t|^2 = \begin{cases} (5.9 \pm 0.8)_{K^{*0}} \times 10^{-3} \\ (6.4 \pm 0.9)_{K^{*+}} \times 10^{-3} \end{cases}$$

[$\approx 15\%$ uncertainty]

\Rightarrow Relatively small uncertainties, **but are they accurate?**

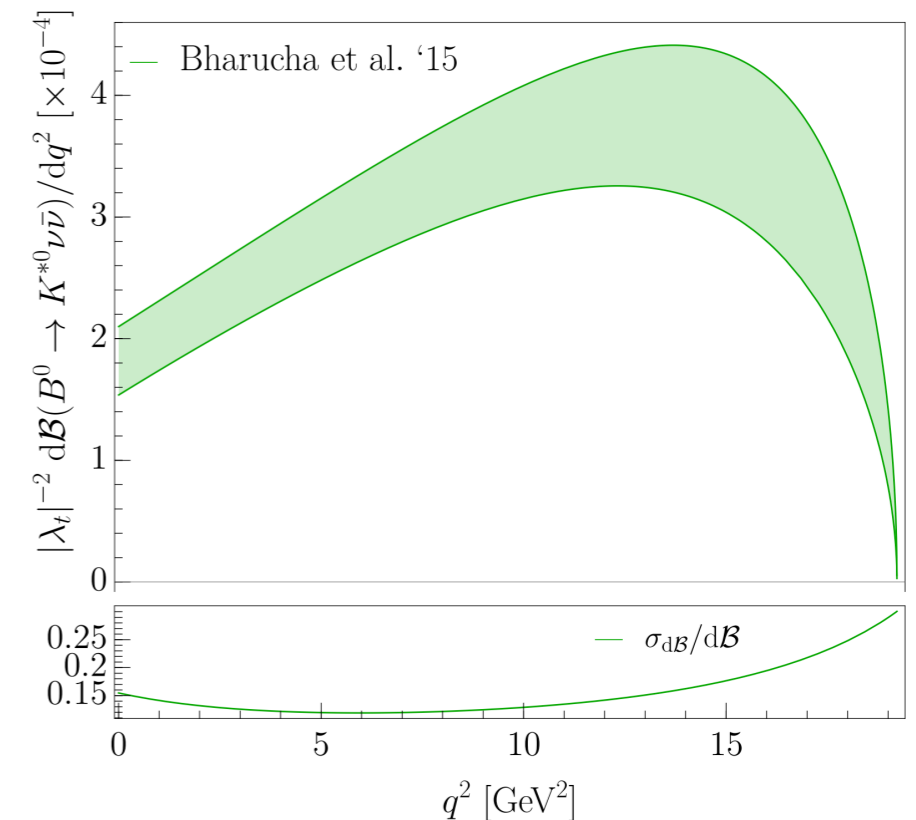

II. Which CKM value?

$$\lambda_t = V_{tb}V_{ts}^*$$

- Using available $b \rightarrow c\ell\bar{\nu}$ data:

$$|\lambda_t| \times 10^3 = \begin{cases} 41.4 \pm 0.8, & (B \rightarrow X_c l \bar{\nu}) \\ 39.3 \pm 1.0, & (B \rightarrow D l \bar{\nu}) \\ 37.8 \pm 0.7, & (B \rightarrow D^* l \bar{\nu}) \end{cases}$$

[HFLAV, '22]

[FLAG, '21]

[HFLAV, '22]

... to be compared to CKM global fits:

cf. also [Martinelli et al. '21]

See talks by Aversano and Fael

$$|\lambda_t|_{\text{UTfit}} = (41.4 \pm 0.5) \times 10^{-2}$$

$$|\lambda_t|_{\text{CKMfitter}} = (40.5 \pm 0.3) \times 10^{-2}$$

- Alternative strategy: to use $\Delta m_{B_s} \propto f_{B_s}^2 \hat{B}_{B_s} |\lambda_t|^2$

[Buras, Venturini. '21, '22]

$$|\lambda_t| \times 10^3 = \begin{cases} 41.9 \pm 1.0, & (N_f = 2 + 1 + 1) \\ 39.2 \pm 1.1, & (N_f = 2 + 1) \end{cases}$$

$$f_{B_s} \sqrt{\hat{B}_{B_s}} = 256 \pm 6 \text{ MeV} \quad (N_f = 2 + 1 + 1)$$

[HPQCD '19]

$$f_{B_s} \sqrt{\hat{B}_{B_s}} = 274 \pm 8 \text{ MeV} \quad (N_f = 2 + 1)$$

[FLAG '21]

There is **not a clear answer** to this **ambiguity** so far.

Summary

[Becirevic, Piazza, OS. 2301.06990]

*Using V_{cb} from $B \rightarrow D\ell\bar{\nu}$ for illustration

Decay	Branching ratio
$B^+ \rightarrow K^+ \nu \bar{\nu}$	$(4.44 \pm 0.14 \pm 0.27) \times 10^{-6}$
$B^0 \rightarrow K_S \nu \bar{\nu}$	$(2.05 \pm 0.07 \pm 0.12) \times 10^{-6}$
$B^+ \rightarrow K^{*+} \nu \bar{\nu}$	$(9.79 \pm 1.30 \pm 0.60) \times 10^{-6}$
$B^0 \rightarrow K^{*0} \nu \bar{\nu}$	$(9.05 \pm 1.25 \pm 0.55) \times 10^{-6}$

FF CKM

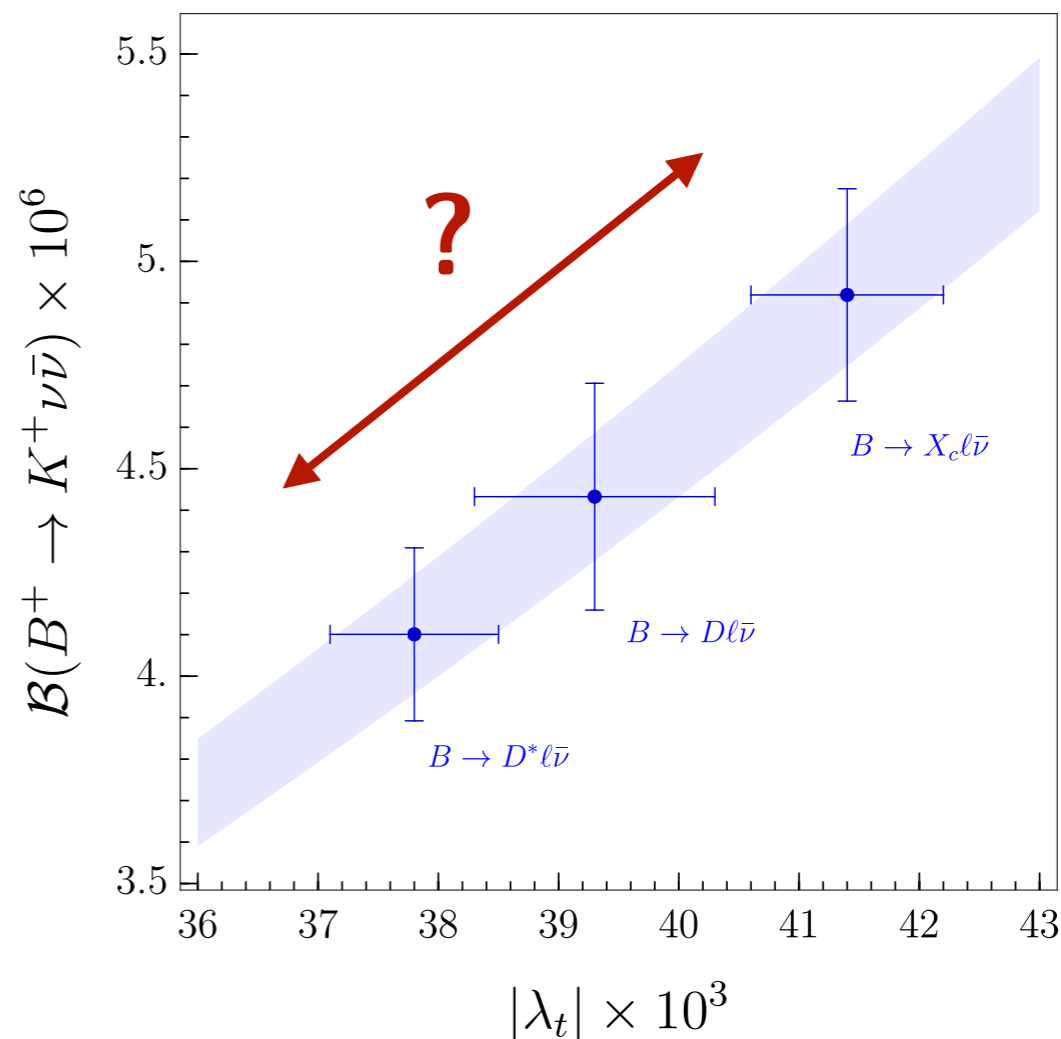

Current Belle-II uncertainty: 0.7×10^{-6}

Projected sensitivity/SM (50 ab^{-1}): $\approx 10\%$

Take-home:

- To remain **cautious** about **hadronic uncertainties** associated with the **form-factors** and the **CKM** values extracted from data — *non-negligible given the projected Belle-II sensitivity.*
- **Binned measurements** at Belle-II would be **valuable** for **testing** the $B \rightarrow K$ form factors.

[NEW] Belle-II results

See talks by M. Liu and J. Libby

[Belle-II, 2311.14647]

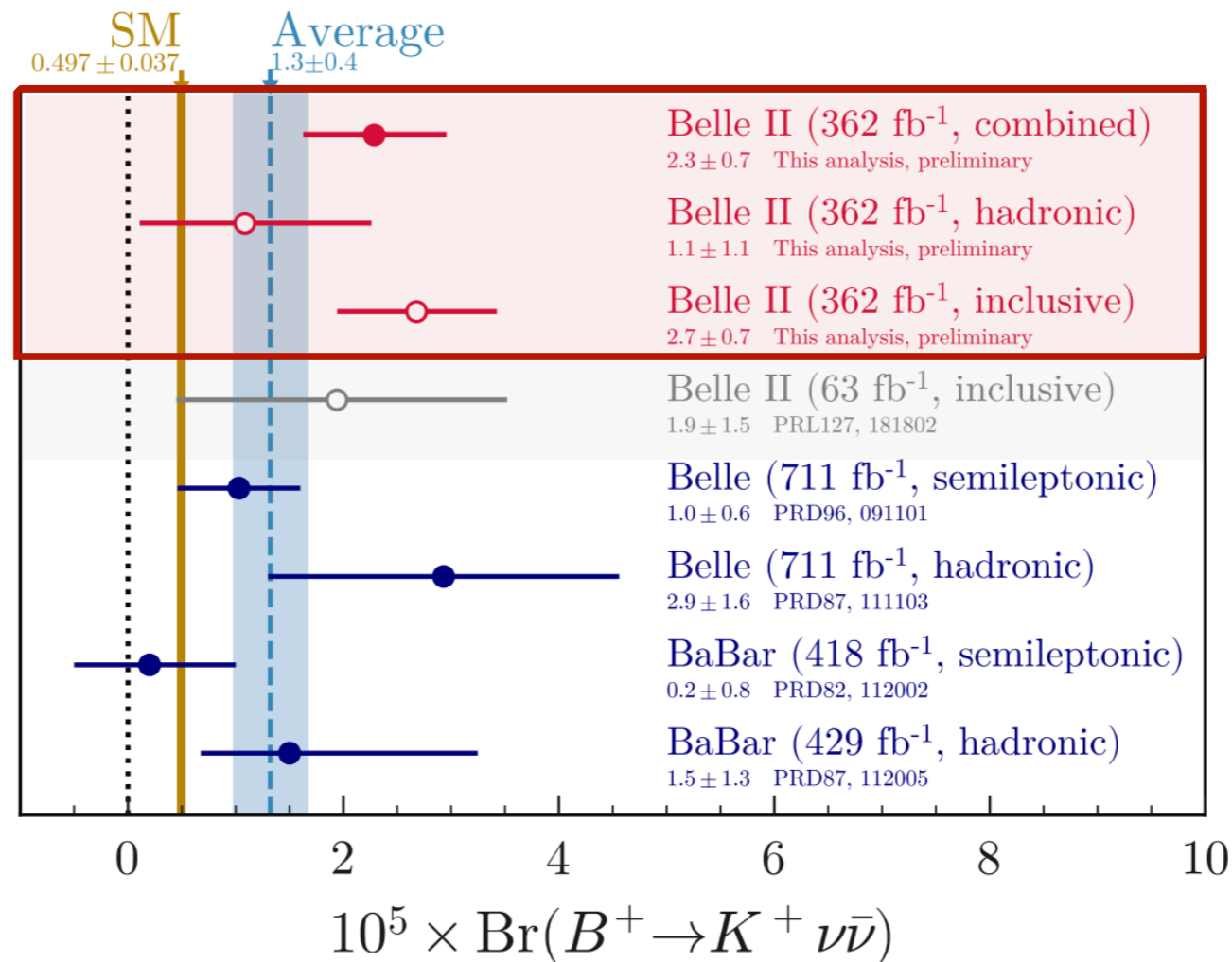

New Belle-II results

First Belle-II result

$$\mathcal{B}(B^+ \rightarrow K^+ \nu \bar{\nu})^{\text{exp}} = [2.3 \pm 0.5 (\text{stat})_{-0.4}^{+0.5} (\text{syst})] \times 10^{-5}$$

≈ 3σ above the SM prediction

⇒ More data is needed! Many possible cross-checks (e.g., $B^0 \rightarrow K_S \nu \bar{\nu}$, semilep. tagging...)

⇒ Can these results be accommodated by new physics?

EFT for $b \rightarrow s\nu\bar{\nu}$

- Low-energy EFT:

see e.g. [Buras et al. '14]

$$\mathcal{L}_{\text{eff}}^{b \rightarrow s\nu\bar{\nu}} = \frac{4G_F \lambda_t \alpha_{\text{em}}}{\sqrt{2} 2\pi} \sum_{ij} \left[C_L^{\nu_i \nu_j} (\bar{s}_L \gamma_\mu b_L) (\bar{\nu}_{Li} \gamma^\mu \nu_{Lj}) + C_R^{\nu_i \nu_j} (\bar{s}_R \gamma_\mu b_R) (\bar{\nu}_{Li} \gamma^\mu \nu_{Lj}) \right] + \text{h.c.},$$

- Complementarity of $B \rightarrow K\nu\bar{\nu}$ and $B \rightarrow K^*\nu\bar{\nu}$:

$$\frac{\mathcal{B}(B \rightarrow K^{(*)}\nu\bar{\nu})}{\mathcal{B}(B \rightarrow K^{(*)}\nu\bar{\nu})^{\text{SM}}} = 1 + \sum_i \frac{2\text{Re}[C_L^{\text{SM}} (\delta C_L^{\nu_i \nu_i} + \delta C_R^{\nu_i \nu_i})]}{3|C_L^{\text{SM}}|^2} + \sum_{i,j} \frac{|\delta C_L^{\nu_i \nu_j} + \delta C_R^{\nu_i \nu_j}|^2}{3|C_L^{\text{SM}}|^2} - \eta_{K^{(*)}} \sum_{i,j} \frac{\text{Re}[\delta C_R^{\nu_i \nu_j} (C_L^{\text{SM}} \delta_{ij} + \delta C_L^{\nu_i \nu_j})]}{3|C_L^{\text{SM}}|^2},$$

$$\eta_K = 0$$

$$\eta_{K^*} = 3.5(1)$$

[Becirevic, Piazza, OS. '22]

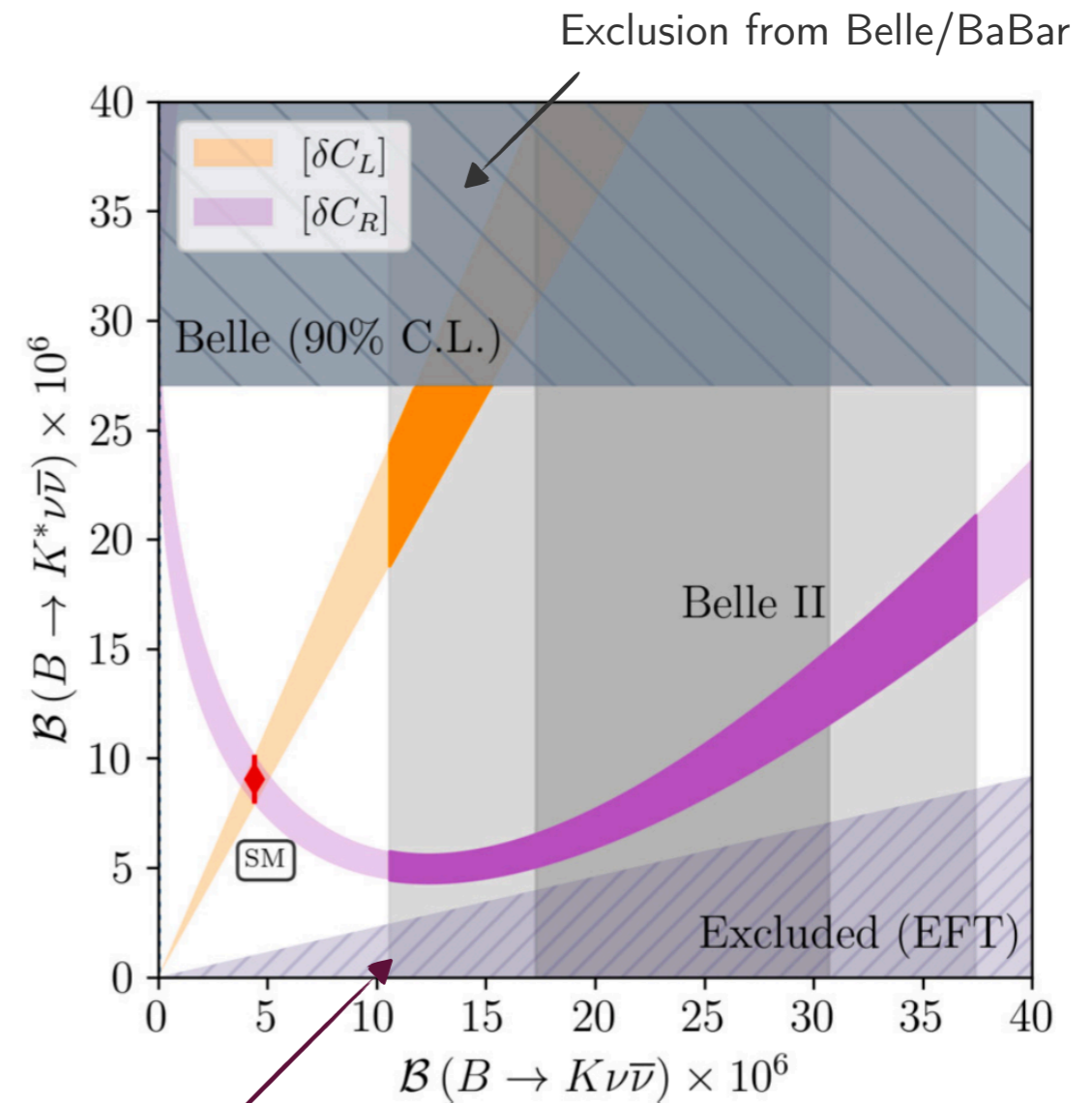

Forbidden region in the EFT approach

[Bause et al. '23]

[Allwicher et al (OS). '23]

Predictions

[Allwicher, Becirevic, Piazza, Rousaro-Alcaraz OS. '23]

- Another observable to measure is the K^* longitudinal-polarisation asymmetry:

$$F_L \equiv \frac{\Gamma_L(B \rightarrow K^* \nu \bar{\nu})}{\Gamma(B \rightarrow K^* \nu \bar{\nu})}$$

$$F_L(B \rightarrow K^* \nu \bar{\nu})^{\text{SM}} = 0.49(7)$$

$$\mathcal{R}_{F_L} \equiv \frac{F_L}{F_L^{\text{SM}}}$$

[Altmannshofer et al. '09, Buras et al. '14, Das et al. '17]

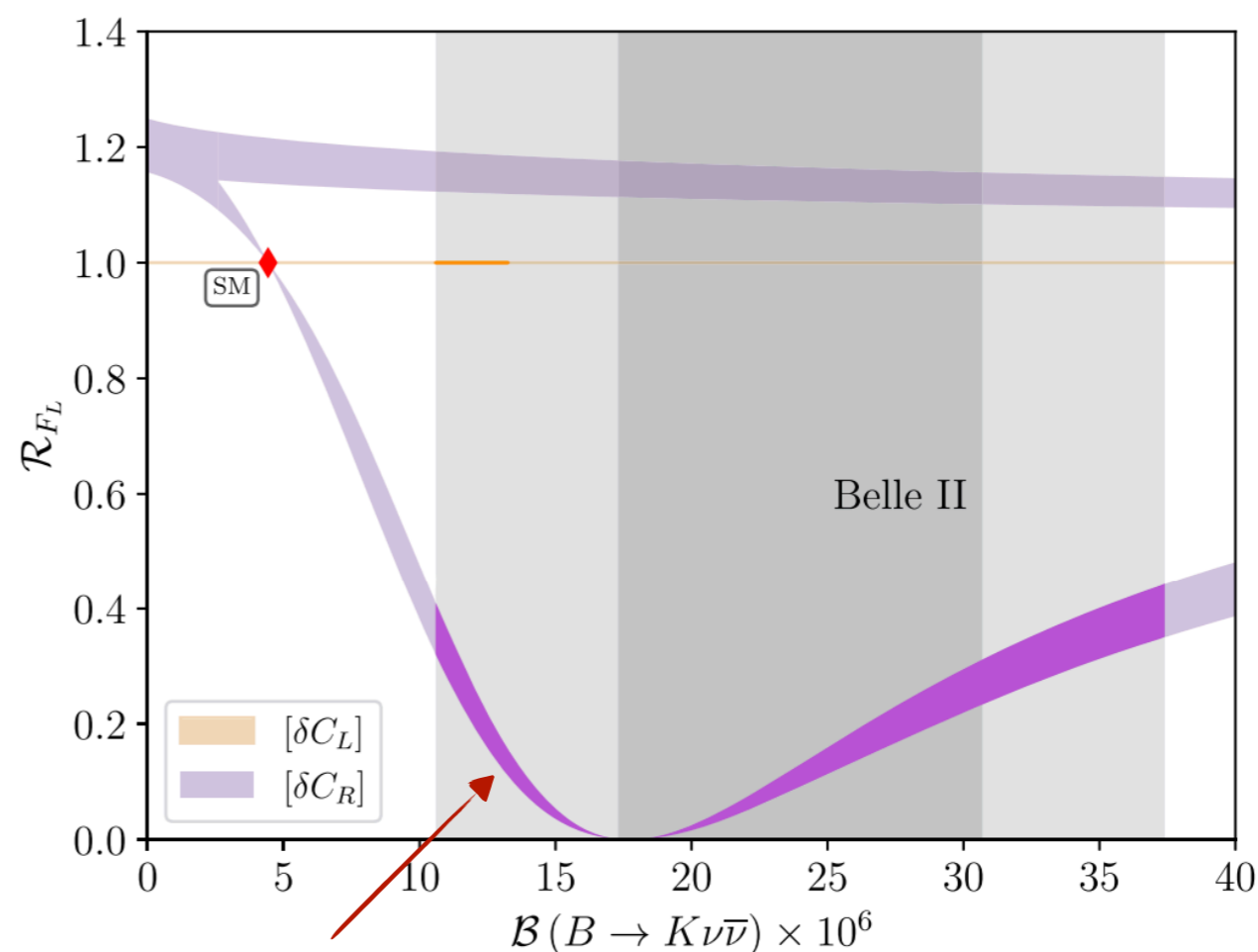
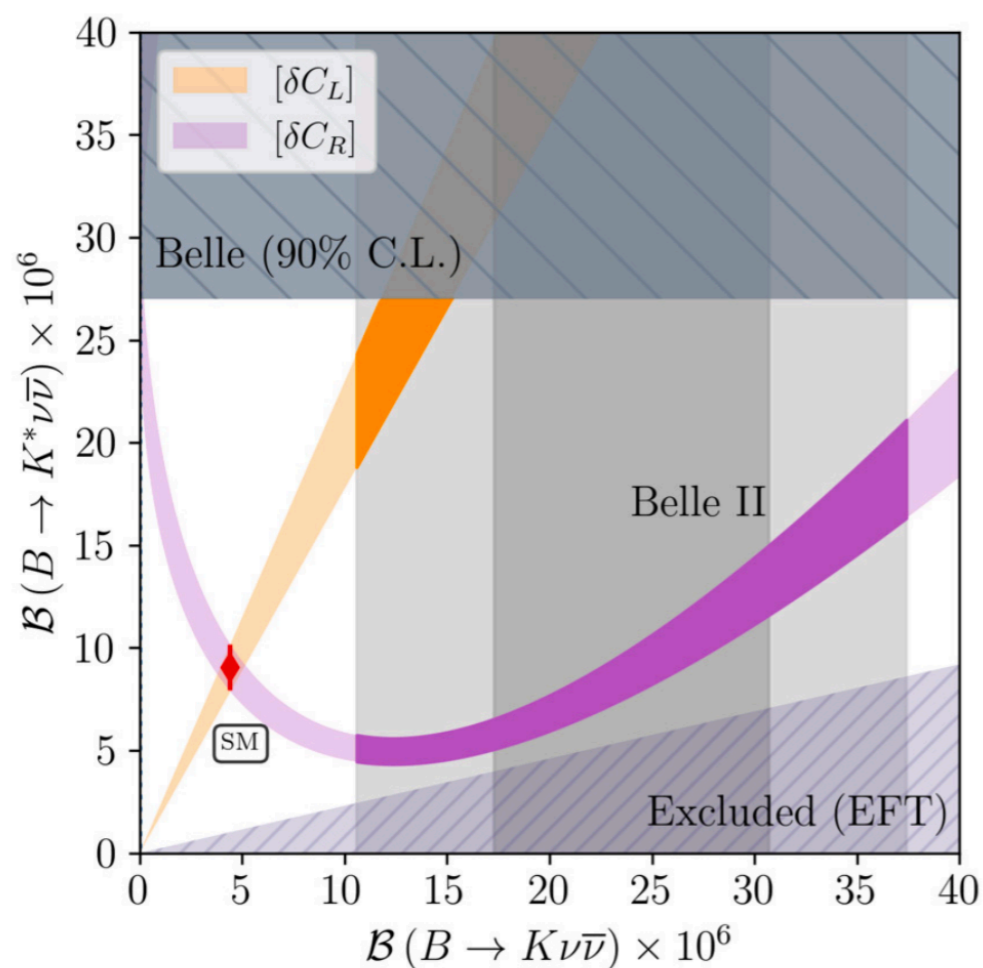

Depletion of SM prediction!

The measurement of $\mathcal{B}(B \rightarrow K^* \nu \bar{\nu})$ and $F_L(B \rightarrow K^* \nu \bar{\nu})$ would be **model-independent tests** of Belle-II results.

SMEFT for $b \rightarrow s\nu\nu$ (and $b \rightarrow s\ell\ell$)

- **SMEFT** is formulated for $\Lambda \gg v_{\text{ew}}$ with $SU(3)_c \times SU(2)_L \times U(1)_Y$ invariant operators.

- Gauge invariance **correlates** $b \rightarrow s\nu\bar{\nu}$ with $b \rightarrow s\ell\bar{\ell}$ since $L_i = (\nu_{Li}, \ell_{Li})^T$.

- Two types of $d = 6$ **contributions** at tree-level:

[Buchmuller & Wyler. '85, Gradkowski et al. '10]

i) $\psi^2 H^2 D$:

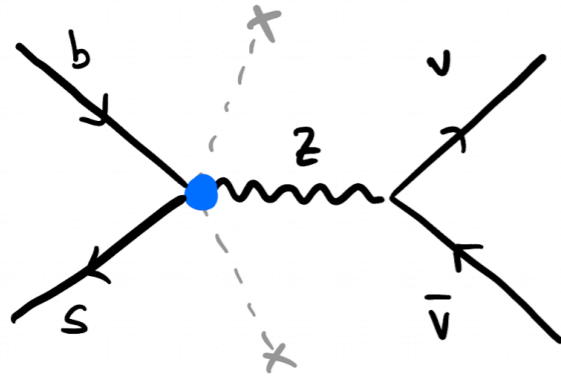

e.g.,

$$\mathcal{O}_{Hd} = (H^\dagger \overleftrightarrow{D}_\mu H) (\bar{s}_R \gamma^\mu b_R)$$

Lepton flavor universal!

ii) ψ^4 :

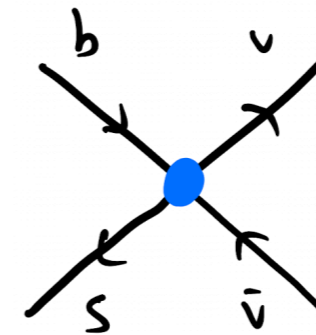

e.g.,

$$\mathcal{O}_{ld} = (\bar{L} \gamma^\mu L) (\bar{s}_R \gamma_\mu b_R)$$

SMEFT for $b \rightarrow s\nu\nu$ (and $b \rightarrow s\ell\ell$)

- **SMEFT** is formulated for $\Lambda \gg v_{\text{ew}}$ with $SU(3)_c \times SU(2)_L \times U(1)_Y$ invariant operators.
- Gauge invariance **correlates** $b \rightarrow s\nu\bar{\nu}$ with $b \rightarrow s\ell\ell$ since $L_i = (\nu_{Li}, \ell_{Li})^T$.
- Two types of $d = 6$ **contributions** at tree-level: [Buchmuller & Wyler. '85, Gradkowski et al. '10]

i) $\psi^2 H^2 D$:

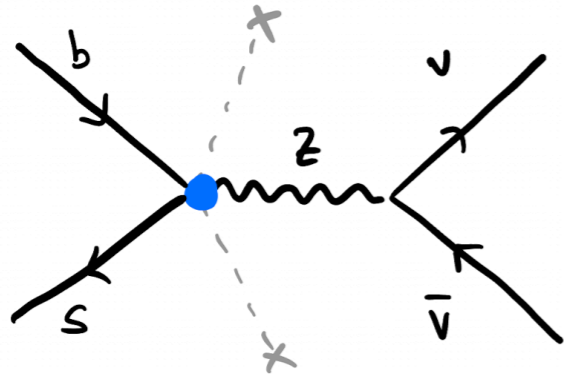

e.g.,

$$\mathcal{O}_{Hd} = (H^\dagger \overleftrightarrow{D}_\mu H)(\bar{s}_R \gamma^\mu b_R)$$

Lepton flavor universal!

⇒ Severely constrained by $\mathcal{B}(B_s \rightarrow \mu\mu)$ and Δm_{B_s} :

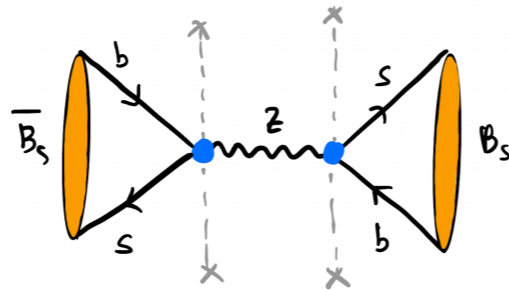
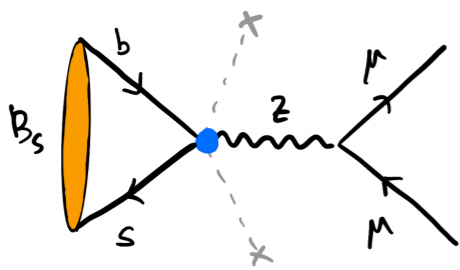

ii) ψ^4 :

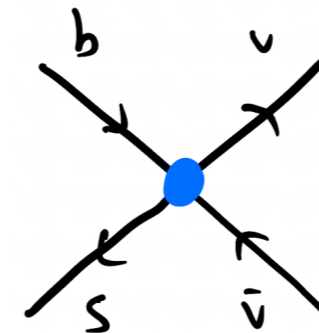

e.g.,

$$\mathcal{O}_{ld} = (\bar{L} \gamma^\mu L)(\bar{s}_R \gamma_\mu b_R)$$

⇒ **Only viable option!**



$$\frac{C}{\Lambda^2} \simeq (5 \text{ TeV})^{-2}$$

SMEFT for $b \rightarrow s\nu\nu$ (and $b \rightarrow s\ell\ell$)

- ψ^4 operators invariant under $SU(2)_L \times U(1)_Y$:

$b \rightarrow s\ell\ell$

$b \rightarrow s\nu\bar{\nu}$

$$[\mathcal{O}_{lq}^{(1)}]_{ijkl} = (\bar{L}_i \gamma^\mu L_j) (\bar{Q}_k \gamma_\mu Q_l)$$

$$[\mathcal{O}_{lq}^{(3)}]_{ijkl} = (\bar{L}_i \gamma^\mu \tau^I L_j) (\bar{Q}_k \tau^I \gamma_\mu Q_l)$$

$$[\mathcal{O}_{ld}]_{ijkl} = (\bar{L}_i \gamma^\mu L_j) (\bar{d}_k \gamma_\mu d_l)$$

$$[\mathcal{O}_{eq}]_{ijkl} = (\bar{e}_i \gamma^\mu e_j) (\bar{Q}_k \gamma_\mu Q_l)$$

$$[\mathcal{O}_{ed}]_{ijkl} = (\bar{e}_i \gamma^\mu e_j) (\bar{d}_k \gamma_\mu d_l)$$

$$[\mathcal{O}_{lq}^{(1)}]_{ijkl} = (\bar{L}_i \gamma^\mu L_j) (\bar{Q}_k \gamma_\mu Q_l)$$

$$= (\bar{\ell}_{Li} \gamma^\mu \ell_{Lj}) (\bar{d}_{Lk} \gamma_\mu d_{Ll}) + (\bar{\nu}_{Li} \gamma^\mu \nu_{Lj}) (\bar{d}_{Lk} \gamma_\mu d_{Ll}) + \dots$$

$$[\mathcal{O}_{lq}^{(3)}]_{ijkl} = (\bar{L}_i \gamma^\mu \tau^I L_j) (\bar{Q}_k \gamma_\mu \tau^I Q_l)$$

$$= (\bar{\ell}_{Li} \gamma^\mu \ell_{Lj}) (\bar{d}_{Lk} \gamma_\mu d_{Ll}) - (\bar{\nu}_{Li} \gamma^\mu \nu_{Lj}) (\bar{d}_{Lk} \gamma_\mu d_{Ll}) + \dots$$

$$[\mathcal{O}_{ld}]_{ijkl} = (\bar{L}_i \gamma^\mu L_j) (\bar{d}_k \gamma_\mu d_l)$$

$$= (\bar{\ell}_{Li} \gamma^\mu \ell_{Lj}) (\bar{d}_{Rk} \gamma_\mu d_{Rl}) + (\bar{\nu}_{Li} \gamma^\mu \nu_{Lj}) (\bar{d}_{Rk} \gamma_\mu d_{Rl})$$

Which flavor?

[Bause et al. '23]

[Allwicher, Becirevic, Piazza, Rousaro-Alcaraz OS. '23]

- Couplings to muons are tightly constrained by $\mathcal{B}(B_s \rightarrow \mu\mu)$ and $R_{K^{(*)}}$. ❌
- The **only viable option** is coupling to τ 's (due to weak exp. limits on $b \rightarrow s\tau\tau$). ✅

⇒ Predictions:

$$\frac{\mathcal{B}(B_s \rightarrow \tau\tau)}{\mathcal{B}(B_s \rightarrow \tau\tau)^{\text{SM}}} \simeq \frac{\mathcal{B}(B \rightarrow K^{(*)}\tau\tau)}{\mathcal{B}(B \rightarrow K^{(*)}\tau\tau)^{\text{SM}}} \simeq 10$$

However, **experimentally challenging...**

see e.g. Capdevilla et al. '17

SMEFT for $b \rightarrow s\nu\nu$ (and $b \rightarrow s\ell\ell$)

- ψ^4 operators invariant under $SU(2)_L \times U(1)_Y$:

$$[\mathcal{O}_{lq}^{(1)}]_{ijkl} = (\bar{L}_i \gamma^\mu L_j) (\bar{Q}_k \gamma_\mu Q_l)$$

$$[\mathcal{O}_{lq}^{(3)}]_{ijkl} = (\bar{L}_i \gamma^\mu \tau^I L_j) (\bar{Q}_k \tau^I \gamma_\mu Q_l)$$

$$[\mathcal{O}_{ld}]_{ijkl} = (\bar{L}_i \gamma^\mu L_j) (\bar{d}_k \gamma_\mu d_l)$$

$$[\mathcal{O}_{eq}]_{ijkl} = (\bar{e}_i \gamma^\mu e_j) (\bar{Q}_k \gamma_\mu Q_l)$$

$$[\mathcal{O}_{ed}]_{ijkl} = (\bar{e}_i \gamma^\mu e_j) (\bar{d}_k \gamma_\mu d_l)$$

- Correlations for concrete mediators:

$$- Z' \sim (\mathbf{1}, \mathbf{1}, 0) : \mathcal{C}_{lq}^{(1)}, \mathcal{C}_{ld}$$

$$- V \sim (\mathbf{1}, \mathbf{3}, 0) : \mathcal{C}_{lq}^{(3)}$$

$$- U_1 \sim (\mathbf{3}, \mathbf{1}, 2/3) : \mathcal{C}_{lq}^{(1)} = \mathcal{C}_{lq}^{(3)}$$

$$- S_3 \sim (\bar{\mathbf{3}}, \mathbf{3}, 1/3) : \mathcal{C}_{lq}^{(1)} = 3\mathcal{C}_{lq}^{(3)}$$

$$- \tilde{R}_2 = (\mathbf{3}, \mathbf{2}, 1/6) : \mathcal{C}_{ld}$$

...

($SU(3)_c, SU(2)_L, U(1)_Y$)

- $B_s - \bar{B}_s$ mixing imposes **strict bounds!**

See back-up!

\Rightarrow Scenarios with a Z' would be in tension with Δm_{B_s} .

\Rightarrow There are LQ models that could explain the excess for $m_{LQ} \lesssim 3$ TeV.

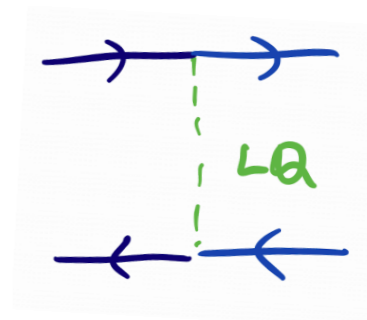
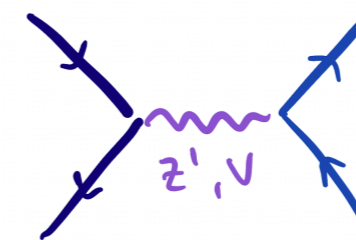

- Many more correlations with low-energy observables** can appear in complete scenarios:

$K^+ \rightarrow \pi^+ \nu \bar{\nu}$ (NA62), $B \rightarrow D^{(*)} \tau \nu$ (LHCb, Belle-II) and Drell-Yan (CMS, ATLAS)

[Marzocca et al. '24]

Other directions?

Hidden sectors?

see e.g. [Izaguirre et al. '17, Gavela et al.'19, Felk et al. '23, Altmannshofer et al. '23]
[Bauer et al. '21, Alonso-Alvarez et al. '23, He et al. '23, Buras et al. '24]...

- $B \rightarrow K + \text{inv}$ is also a probe of light/invisibles particles — different EFT description needed:

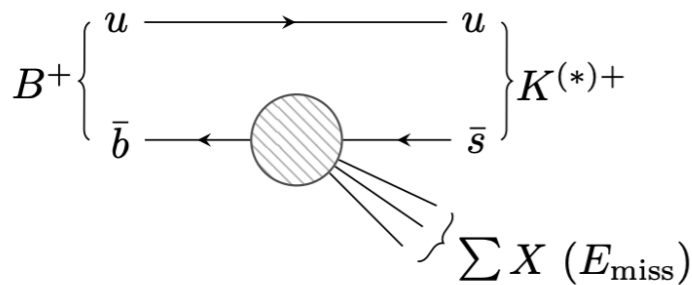

$$B \rightarrow KX$$

$$B \rightarrow K\nu_L\nu_R$$

$$B \rightarrow K\chi\chi$$

$$B \rightarrow K\phi\phi$$

...

[Kamenik et al. '11, Bolton et al. '24, Rosauero-Alcaraz, Leal. '24]

- If the excess is due to $B \rightarrow KX(\rightarrow \text{inv})$, where $X \sim (1, 1, 0)$ is a mediator produced on-shell (*i.e.*, with $m_X < m_B$), the main difference would be a **peak** at $q^2 \simeq m_X^2$.
- Good fit** to Belle-II data too, since the excess is mostly localised (within large uncertainties):

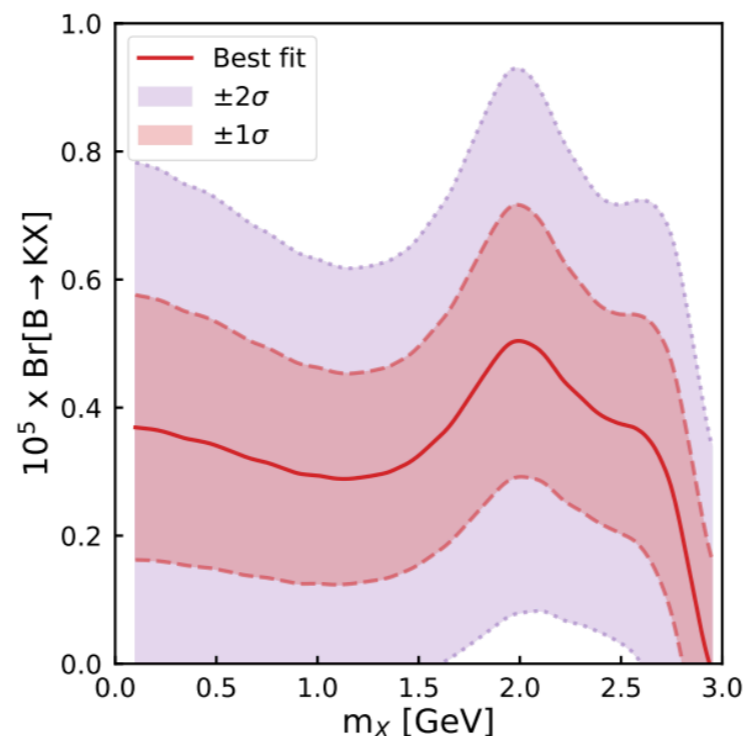
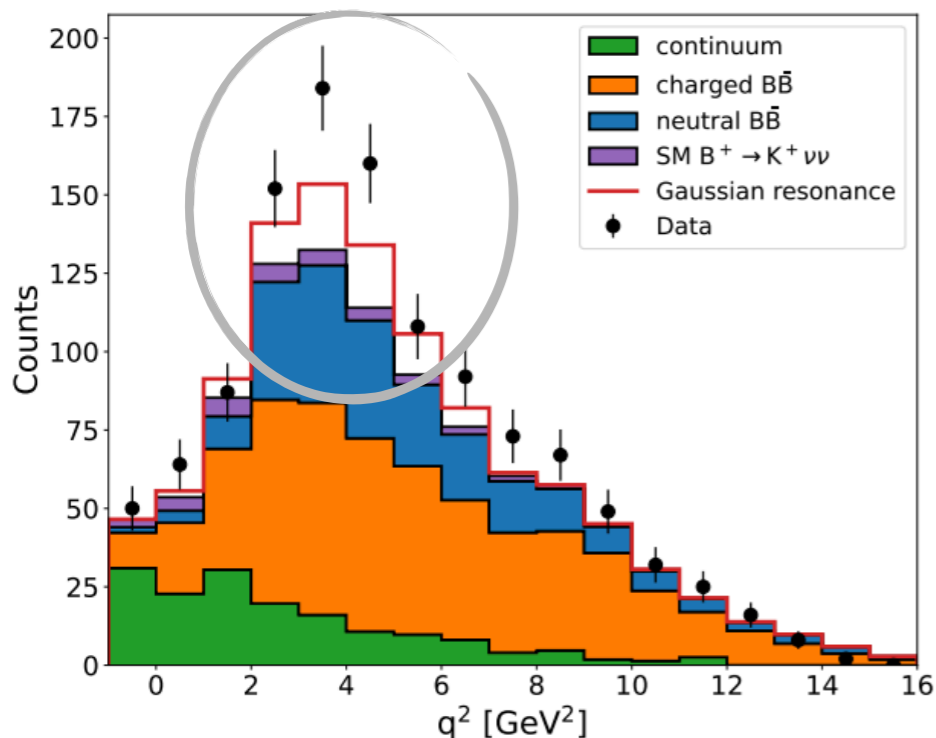

Best fit (2.8σ): $m_X \approx 2 \text{ GeV}$

$$\mathcal{B}(B \rightarrow KX) = (5.1 \pm 2.1) \times 10^{-6}$$

[Altmannshofer et al. '23]

⇒ To be checked by **dedicated searches!**

See talk by Novoa-Brunet

Summary & Outlook

Summary & Outlook

- **Precision frontier:** fundamental to seek new physics particles that cannot be produced on-shell at the LHC — *complementary approach!*
- **Hadronic uncertainties:** QCD remains the main obstacle to using low-energy observables to probe new physics — *caution is advised!*
- V_{cb} : theory and exp. progress is needed to solve this issue — *needed to fix the parametric uncertainties of rare decays in the SM...* Belle-II data and new LQCD results will be essential.
- $B \rightarrow K\nu\nu$: Theoretically clean and very helpful to constrain (B)SM physics. More data and further cross-checks are needed to understand the first Belle-II results — *e.g., $B^0 \rightarrow K_S\nu\bar{\nu}$, $B \rightarrow K^*\nu\bar{\nu}$ and $F_L(B \rightarrow K^*\nu\bar{\nu})$.*

Many opportunities to explore physics (B)SM in flavor experiments!

Thank you!

Back-up

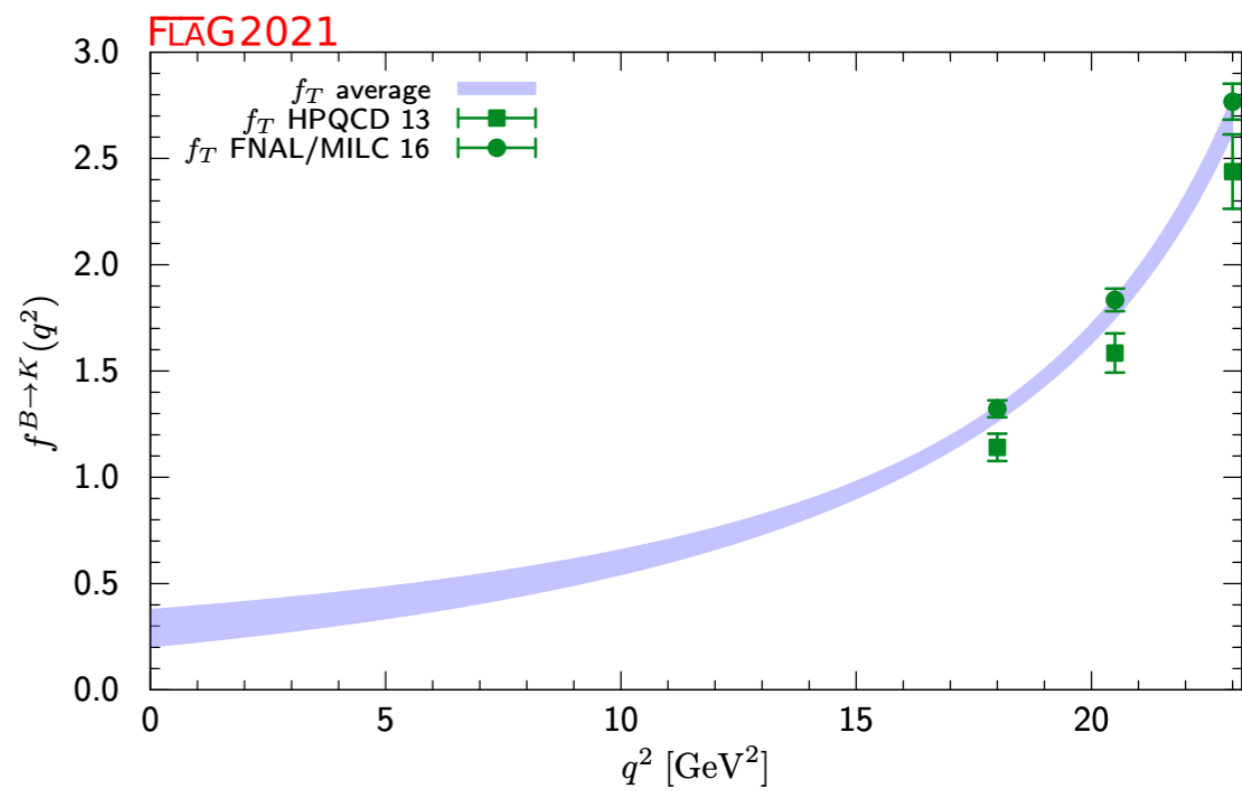
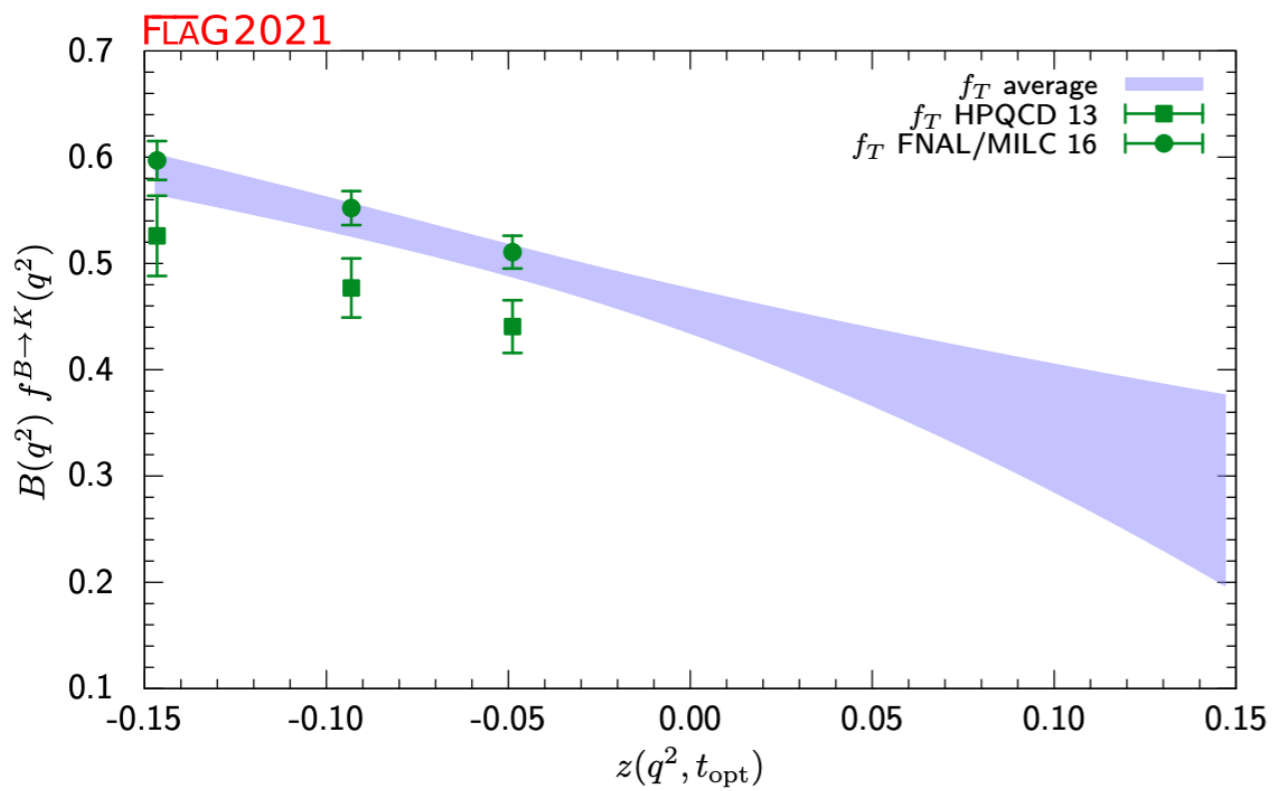
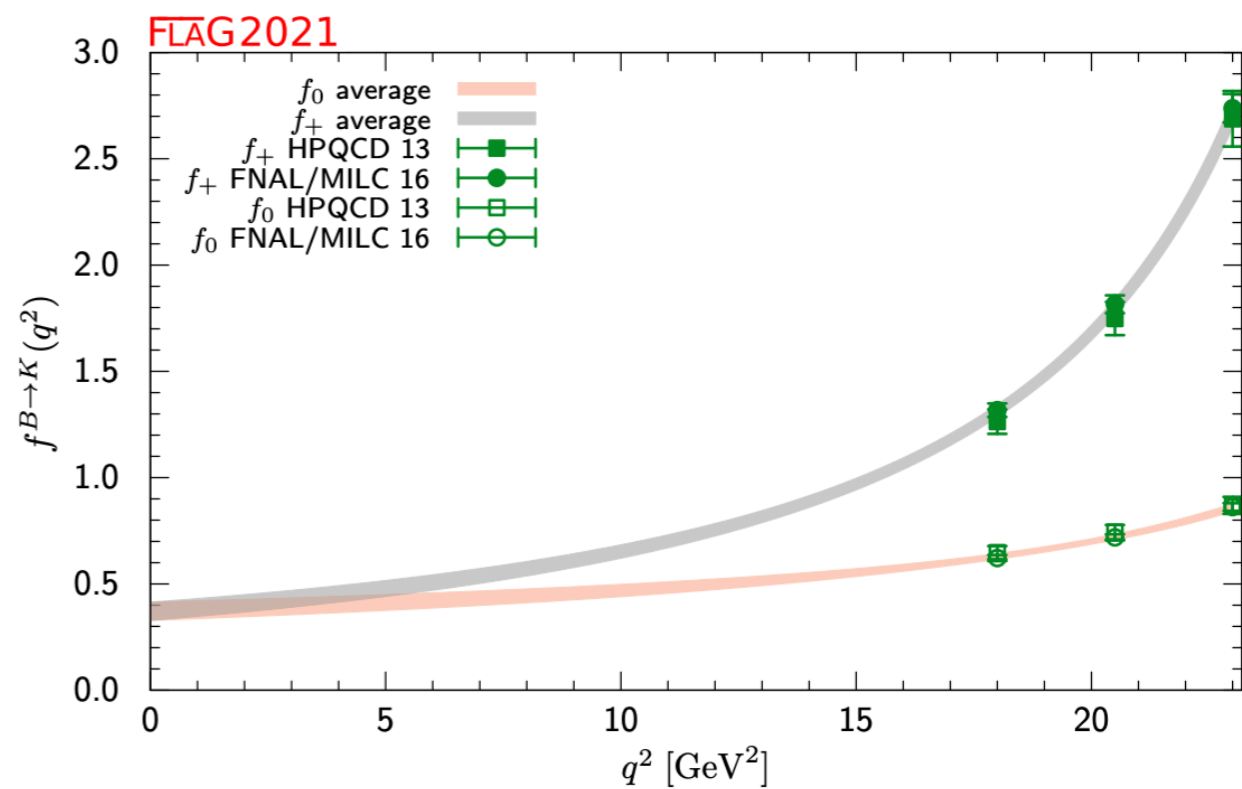
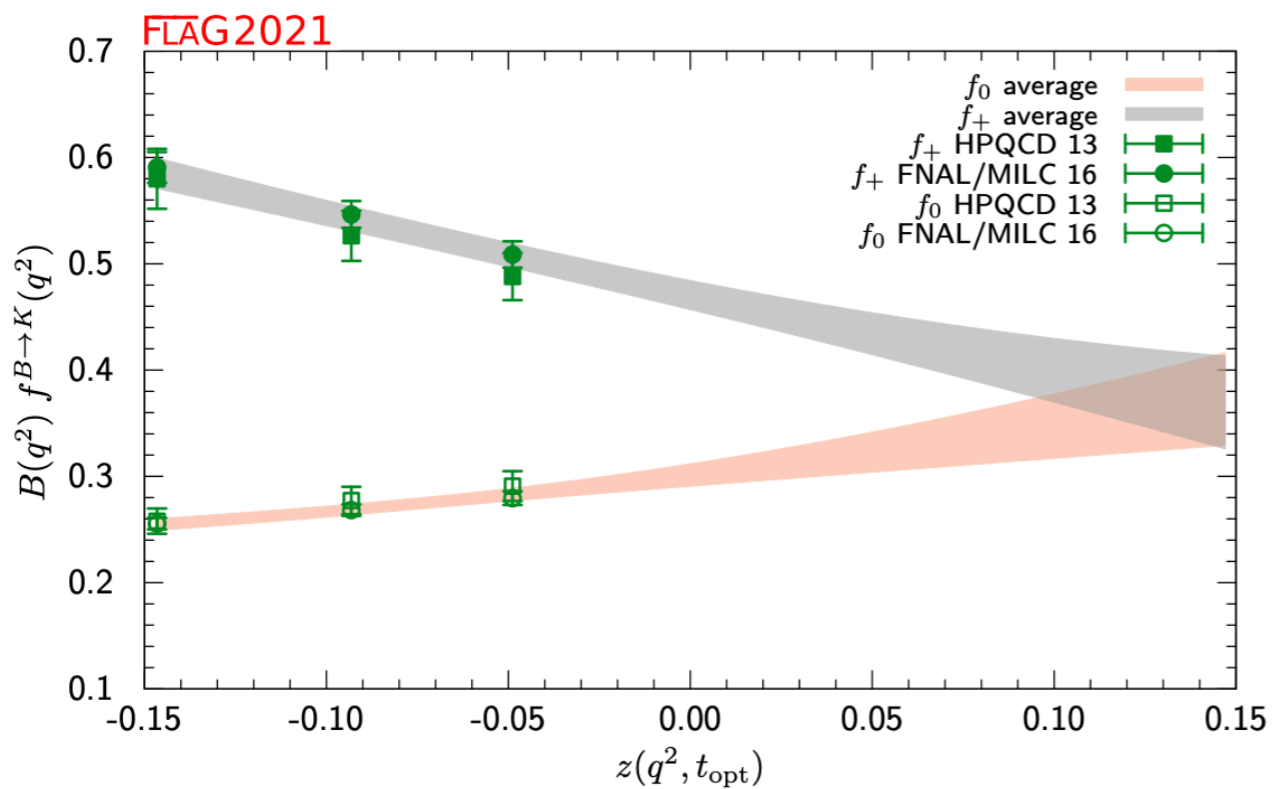

$$f_+(q^2) = \frac{1}{P_+(q^2)} \sum_{n=0}^{N-1} a_n^+ \left[z^n - (-1)^{n-N} \frac{n}{N} z^N \right]$$

$$f_T(q^2) = \frac{1}{P_T(q^2)} \sum_{n=0}^{N-1} a_n^T \left[z^n - (-1)^{n-N} \frac{n}{N} z^N \right]$$

$$f_0(q^2) = \frac{1}{P_0(q^2)} \sum_{n=0}^{N-1} a_n^0 z^n,$$

$$P_i(q^2) = 1 - q^2/M_i^2,$$

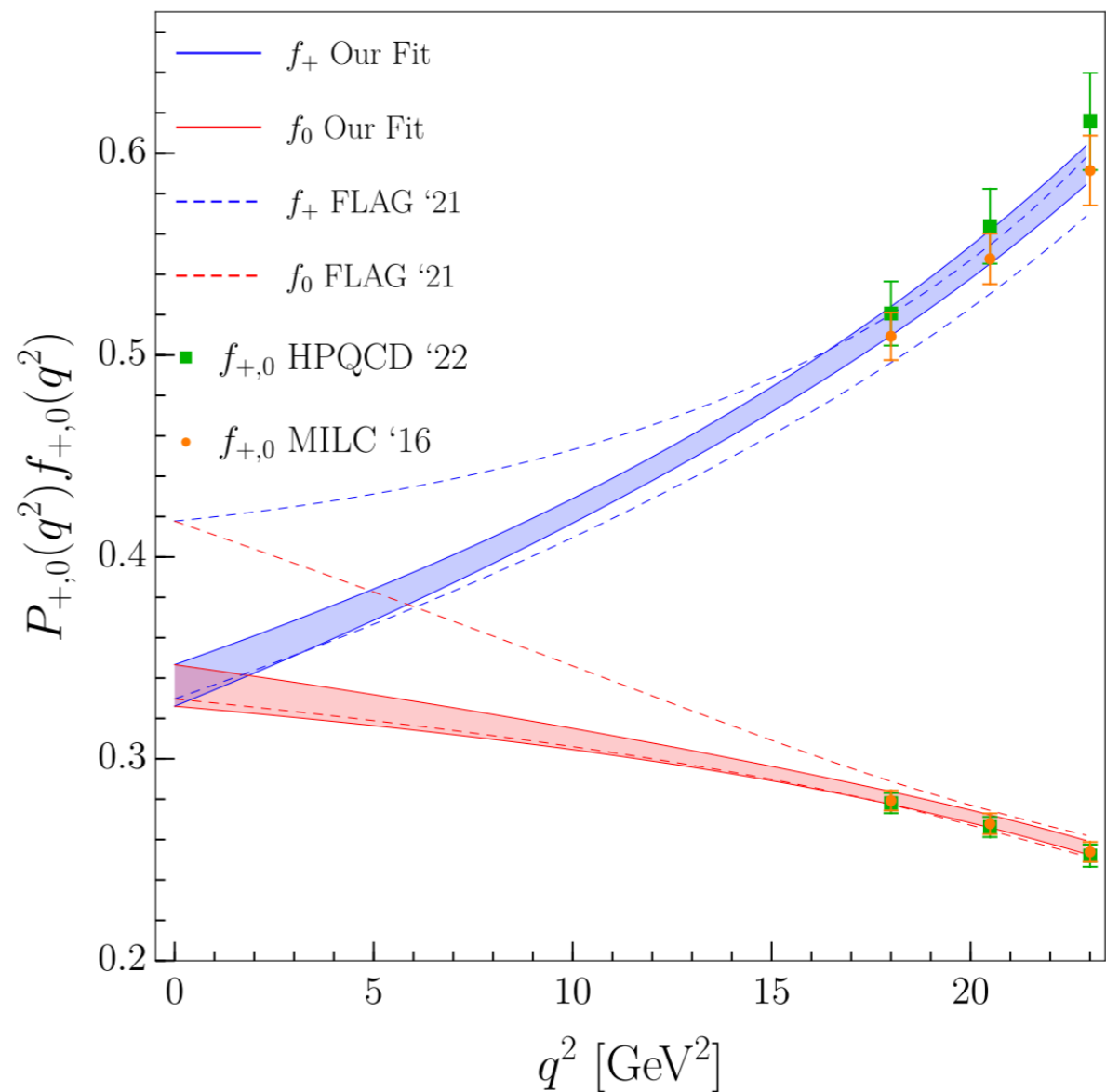
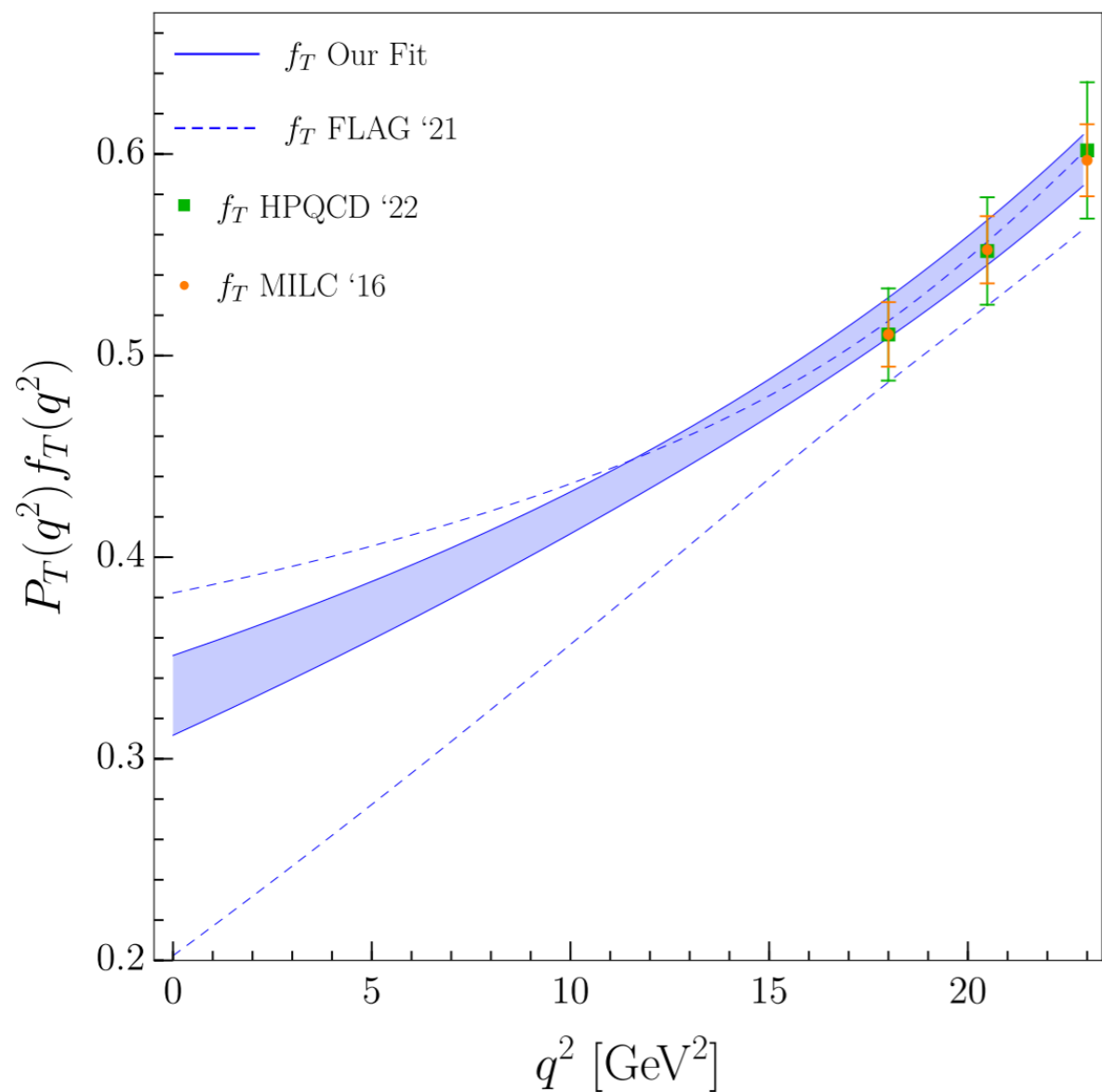

Table 3: Baseline (improved) expectations for the uncertainties on the signal strength μ (relative to the SM strength) for the four decay modes as functions of data set size.

Decay	1 ab ⁻¹	5 ab ⁻¹	10 ab ⁻¹	50 ab ⁻¹
$B^+ \rightarrow K^+ \nu \bar{\nu}$	0.55 (0.37)	0.28 (0.19)	0.21 (0.14)	0.11 (0.08)
$B^0 \rightarrow K_S^0 \nu \bar{\nu}$	2.06 (1.37)	1.31 (0.87)	1.05 (0.70)	0.59 (0.40)
$B^+ \rightarrow K^{*+} \nu \bar{\nu}$	2.04 (1.45)	1.06 (0.75)	0.83 (0.59)	0.53 (0.38)
$B^0 \rightarrow K^{*0} \nu \bar{\nu}$	1.08 (0.72)	0.60 (0.40)	0.49 (0.33)	0.34 (0.23)

[NEW] Warning!

$$\frac{d\mathcal{B}}{dq^2}(B \rightarrow D^* \ell \nu) \propto |V_{cb}|^2 |\mathcal{F}(w)|^2$$

$$\left[w = \frac{m_B^2 + m_{D^*}^2 - q^2}{2m_B m_{D^*}} \right]$$

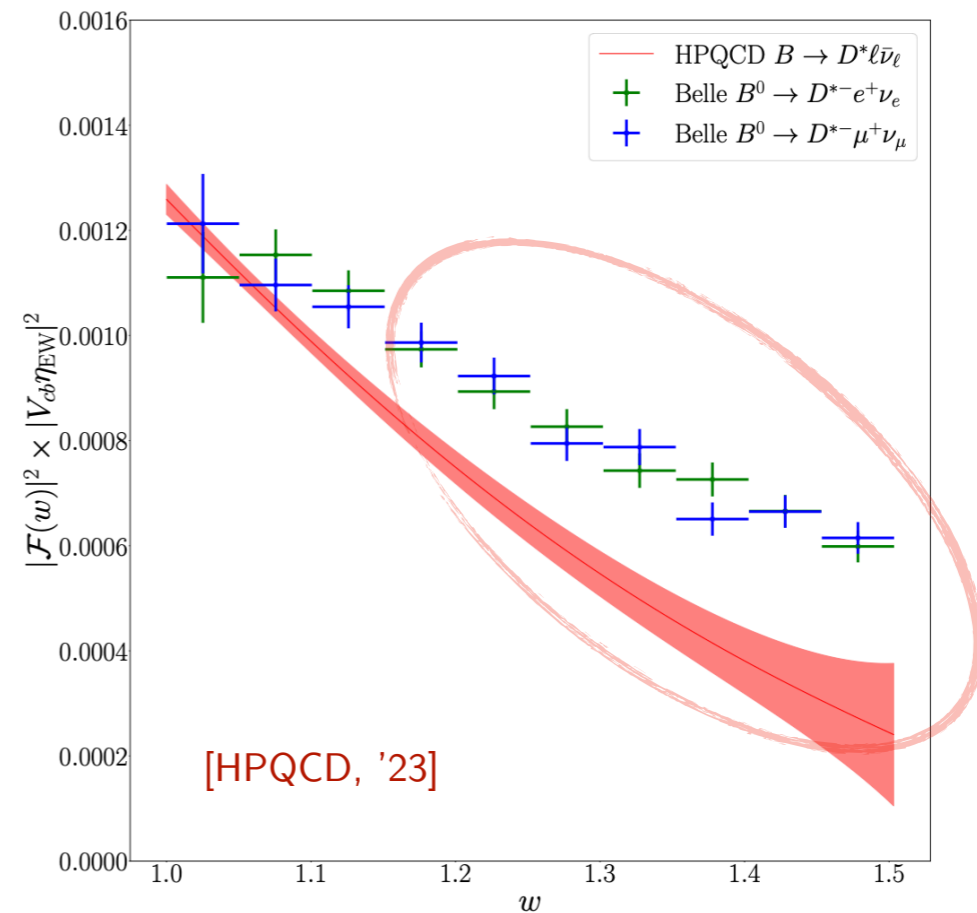
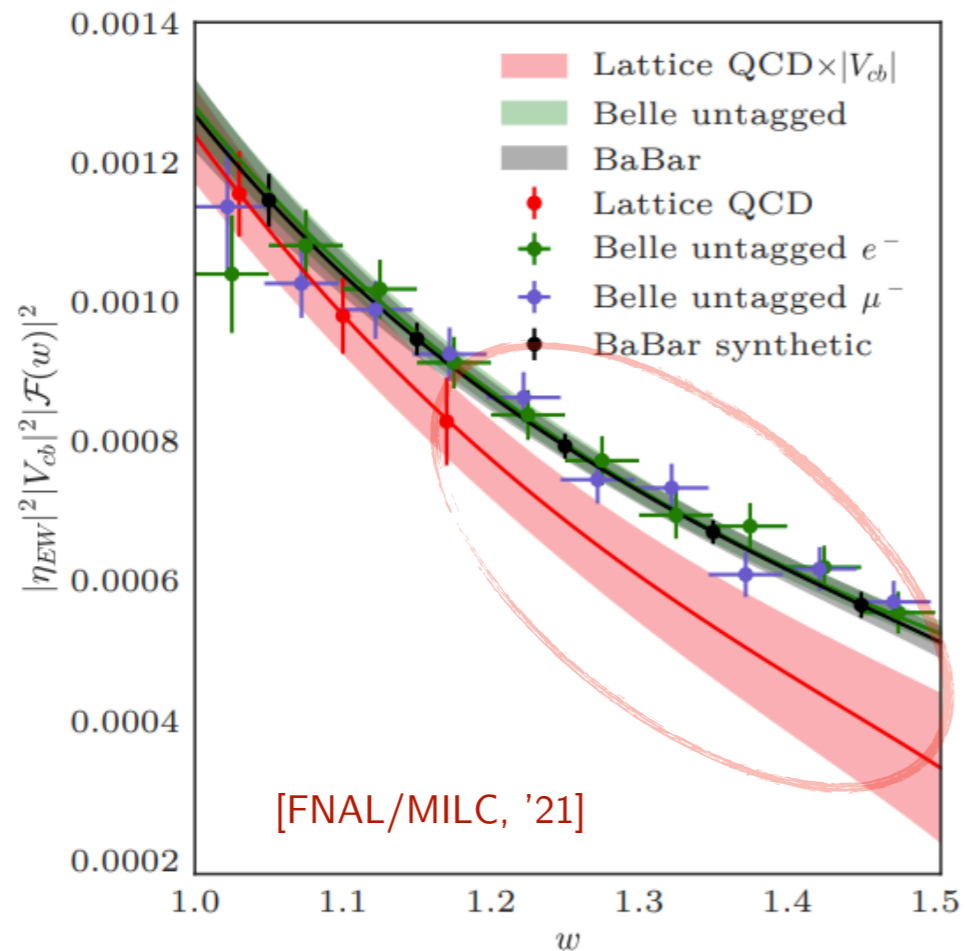

⇒ Needs clarification to reliably extract $|V_{cb}|$ from $B \rightarrow D^* \ell \bar{\nu}$...

NB. Recent JLQCD agrees well with exp. data!

Comparison from A. Lytle talk

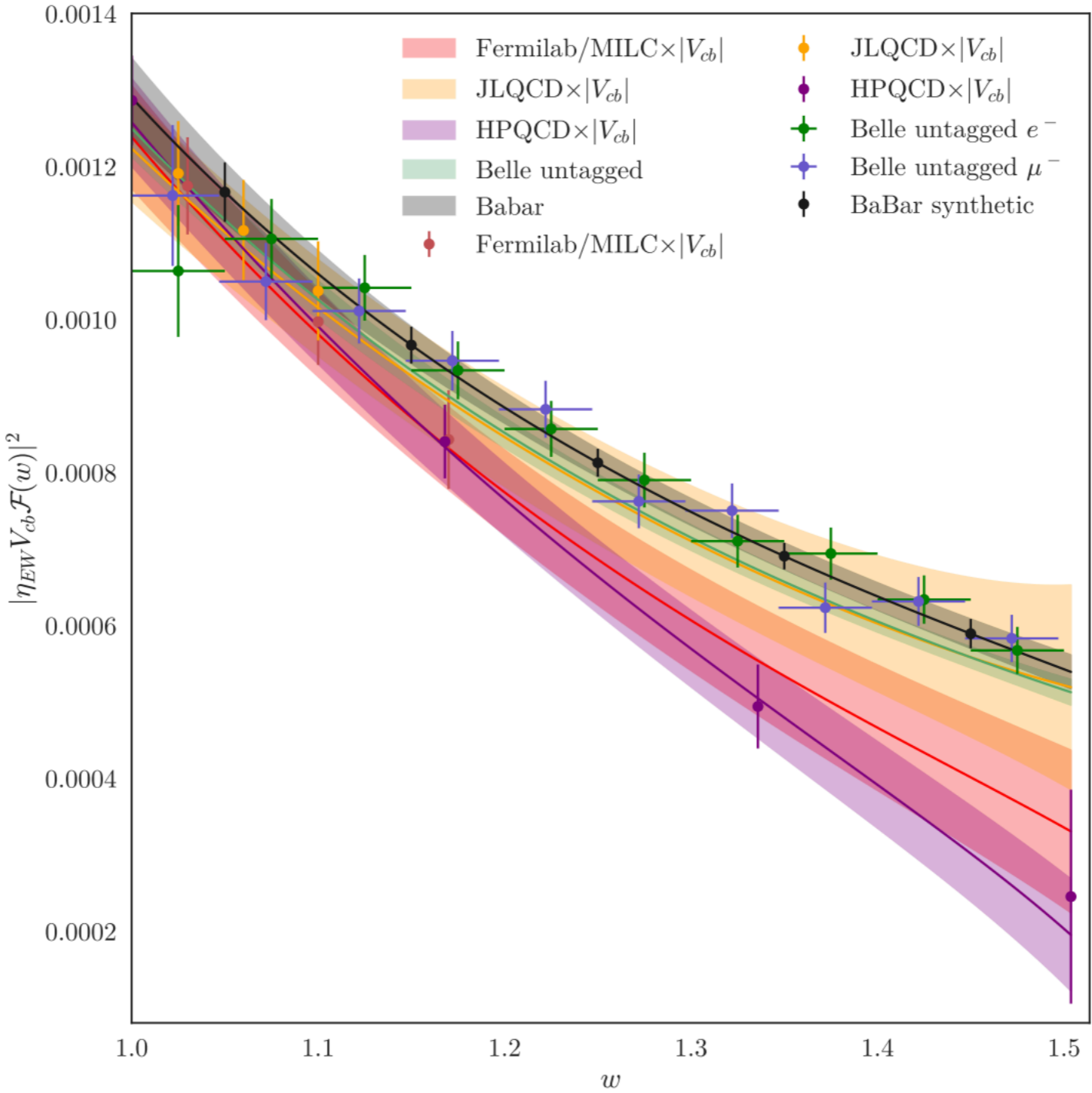

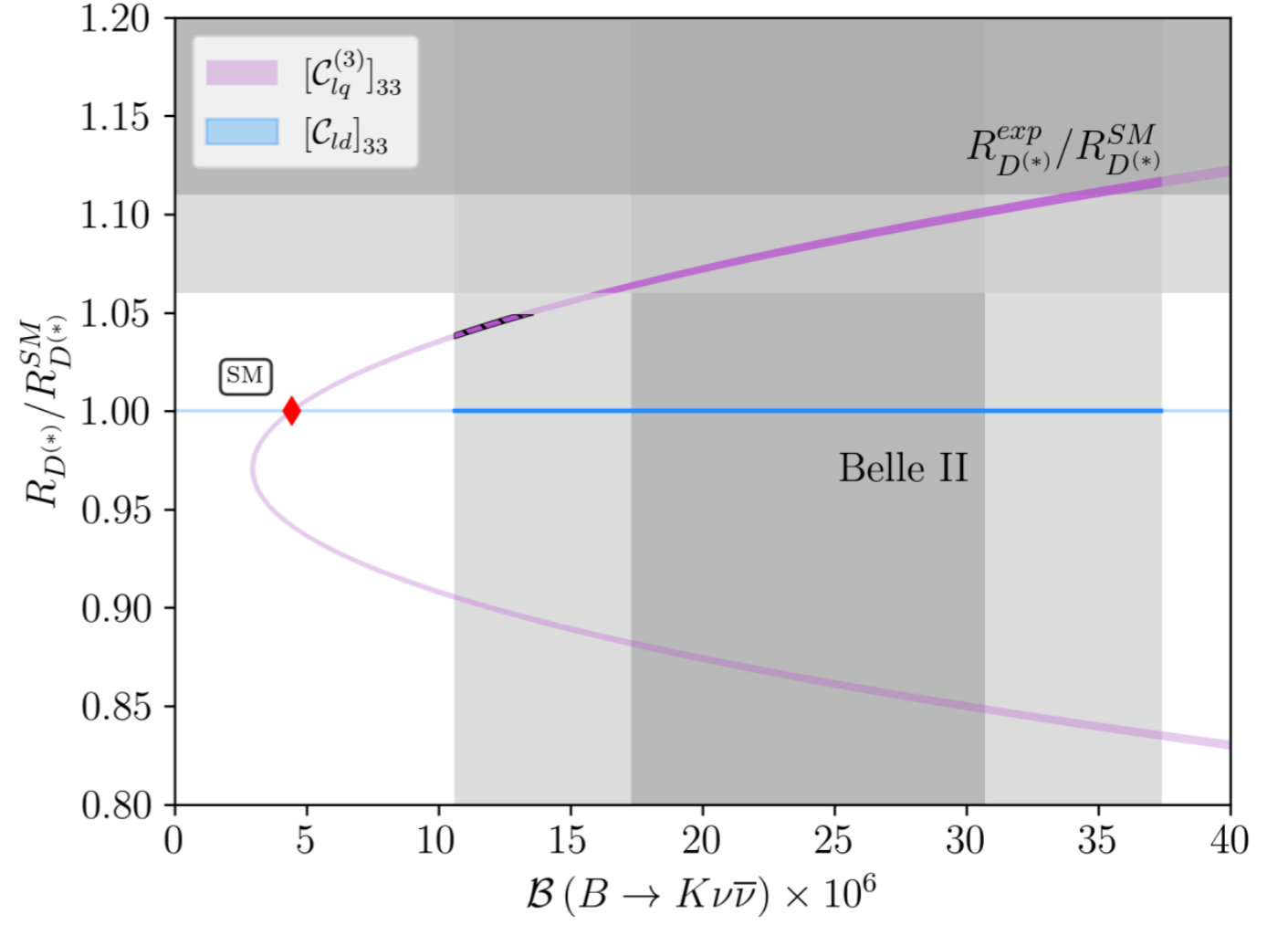
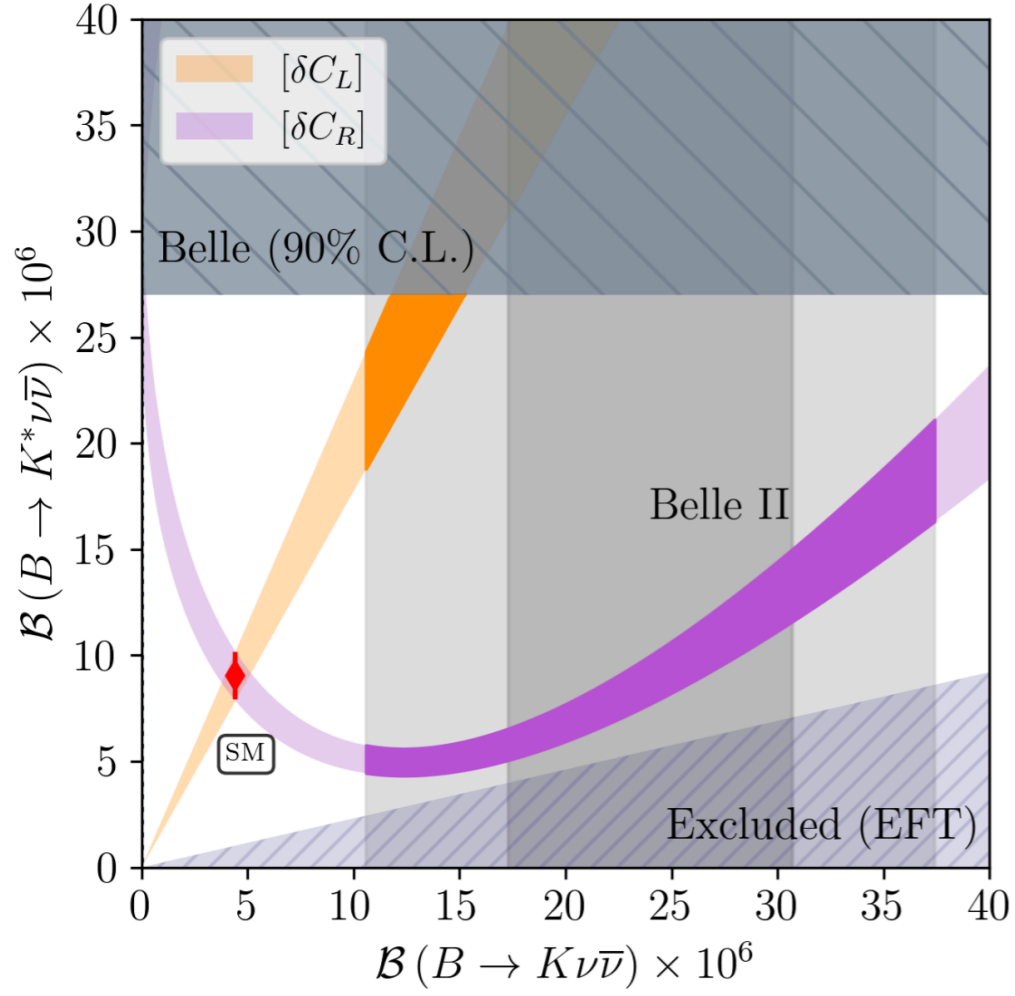

$$\begin{aligned}
\mathcal{L}_{\text{SMEFT}}^{(6)} \supset & \frac{1}{\Lambda^2} \left\{ \left(\mathcal{C}_{lq}^{(1)} + \mathcal{C}_{lq}^{(3)} \right)_{ij} (\bar{s}_L \gamma^\mu b_L) (\bar{e}_{Li} \gamma_\mu e_{Lj}) \right. \\
& + \left(\mathcal{C}_{lq}^{(1)} - \mathcal{C}_{lq}^{(3)} \right)_{ij} (\bar{s}_L \gamma^\mu b_L) (\bar{\nu}_{Li} \gamma_\mu \nu_{Lj}) \\
& + 2 V_{cs} \left[\mathcal{C}_{lq}^{(3)} \right]_{ij} (\bar{c}_L \gamma^\mu b_L) (\bar{e}_{Li} \gamma_\mu \nu_{Lj}) \\
& \left. + [\mathcal{C}_{ld}]_{ij} (\bar{s}_R \gamma^\mu b_R) [(\bar{\nu}_{Li} \gamma_\mu \nu_{Lj}) + (\bar{e}_{Li} \gamma_\mu e_{Lj})] + \text{h.c.} \right\},
\end{aligned}$$

Remarks on $B \rightarrow K^{(*)}\nu\nu / B \rightarrow K^{(*)}\mu\mu$

- $B \rightarrow K^{(*)}\nu\nu$ and $B \rightarrow K^{(*)}\mu\mu$ have a similar decay spectrum away from the narrow $c\bar{c}$ resonances:

[Becirevic, Piazza, OS. 2301.06990] [Bartsch et al. '09]

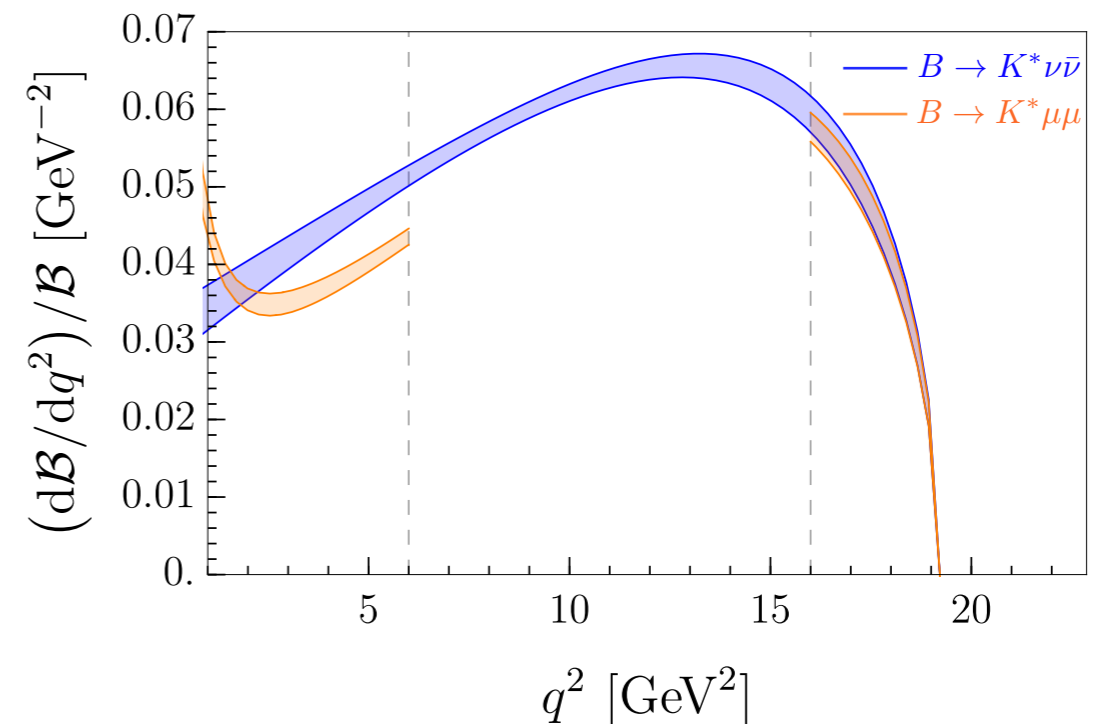
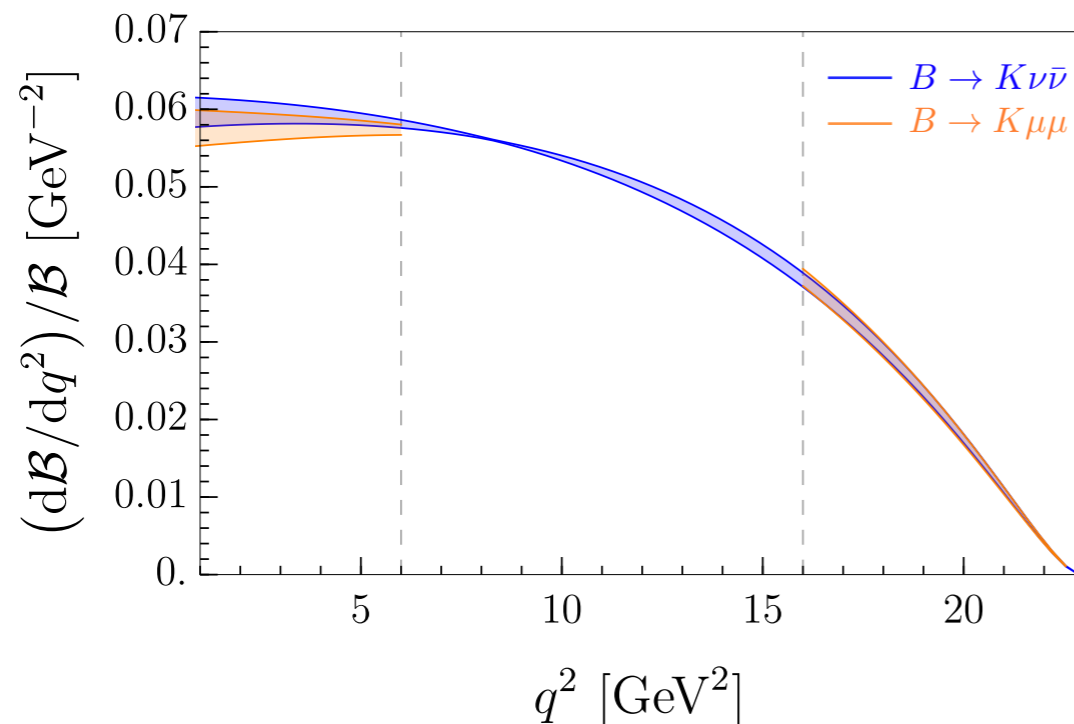

*using 2-loop results for $c\bar{c}$ loops from [Asatryan et al. '09]

- We can define the **CKM-free ratio**:

$$\mathcal{R}_{K^{(*)}}^{(\nu/l)}[q_0^2, q_1^2] \equiv \frac{\mathcal{B}(B \rightarrow K^{(*)}\nu\bar{\nu})}{\mathcal{B}(B \rightarrow K^{(*)}ll)} \Big|_{[q_0^2, q_1^2]}$$

Ratio of partial branching fractions integrated in the same q^2 -bin.

\Rightarrow **Form-factor** uncertainties **cancel out** to a good extent for $q^2 \gg m_\ell^2$.

\Rightarrow Neglecting NP contributions, this ratio can be used to **extract** $C_9^{\mu\mu}$!

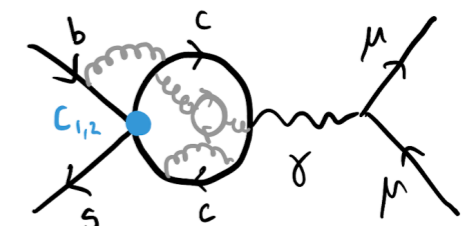

See back-up!

- Predictions using perturbative calculation of $c\bar{c}$ loops:

[Becirevic, Piazza, OS. 2301.06990]

$$\mathcal{R}_K^{(\nu/l)}[1.1, 6] \Big|_{\text{SM}} = 7.58 \pm 0.04$$

$$\mathcal{R}_{K^*}^{(\nu/l)}[1.1, 6] \Big|_{\text{SM}} = 8.6 \pm 0.3$$

with the following dependence on C_9^{eff} :

using [Asatryan et al. '09]

$$\frac{1}{\mathcal{R}_K^{(\nu/l)}[1.1, 6] \Big|_{\text{SM}}} \simeq \left[7.15 - 0.45 \cdot C_9^{\text{eff}} + 0.42 \cdot (C_9^{\text{eff}})^2 \right] \times 10^{-2}$$

$$\frac{1}{\mathcal{R}_{K^*}^{(\nu/l)}[1.1, 6] \Big|_{\text{SM}}} \simeq \left[9.98 - 1.45 \cdot C_9^{\text{eff}} + 0.42 \cdot (C_9^{\text{eff}})^2 \right] \times 10^{-2}$$

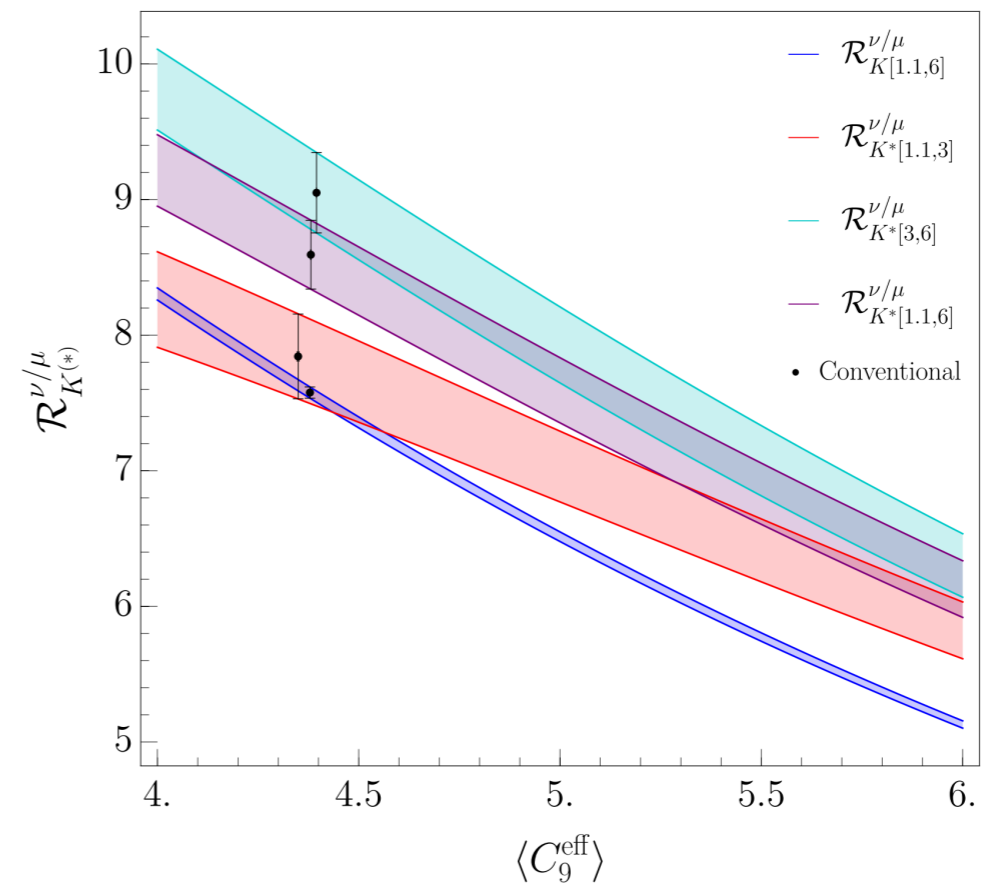
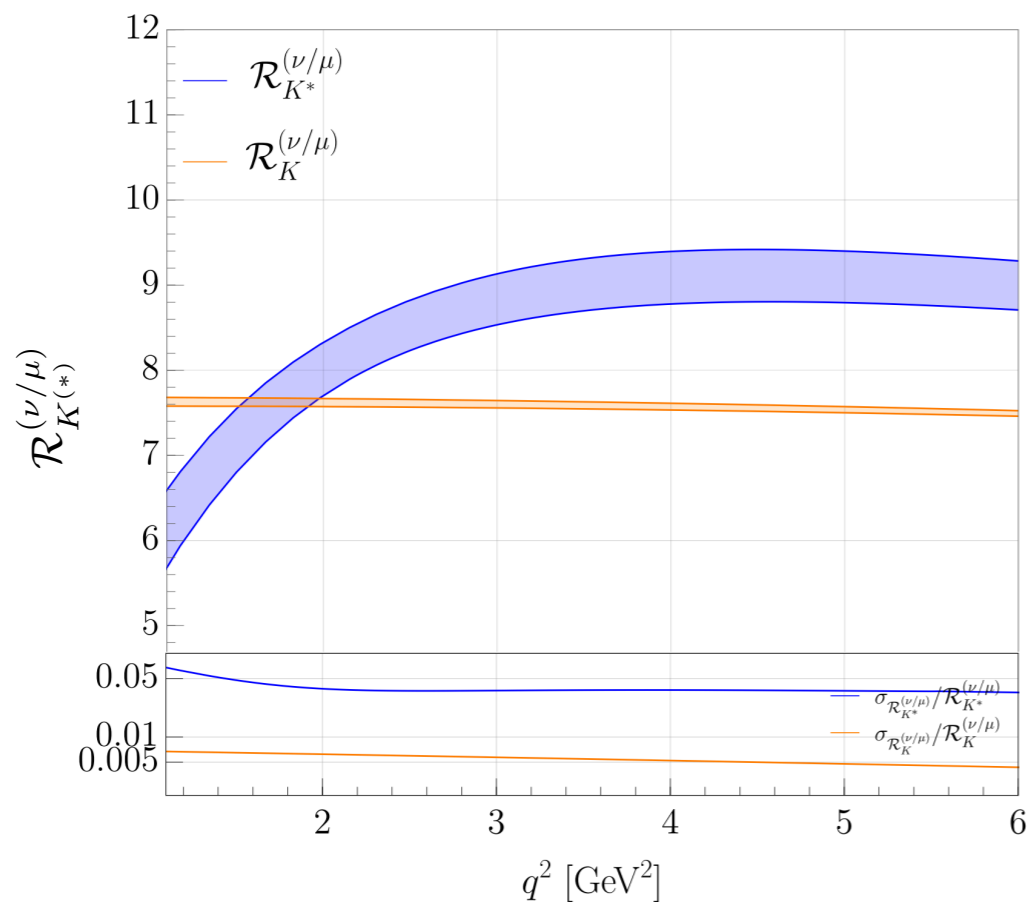

Precise measurements could help us to understand the various anomalies in $b \rightarrow s\mu\mu$ data.

Which concrete model?

[Allwicher, Becirevic, Piazza, Rousaro-Alcaraz OS. '23]

- More **correlations** between **observables** can arise in **concrete models**:

- Z' :

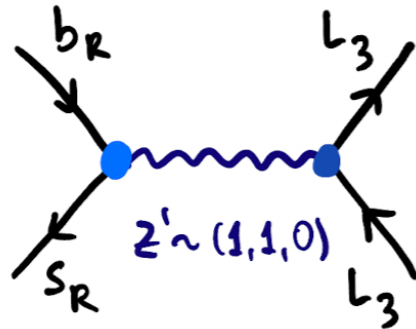

$$\mathcal{L}_{Z'} \supset g_{ij}^\psi (\bar{\psi}_i \gamma^\mu \psi_j) Z'_\mu$$

- LQs:

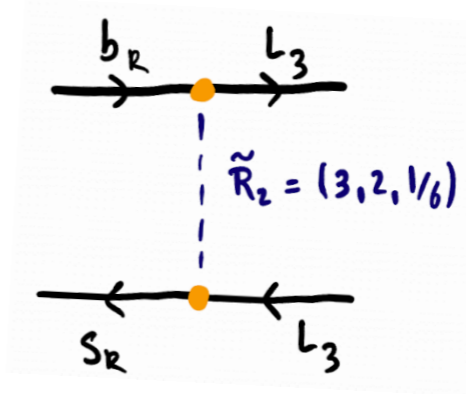

$$\mathcal{L}_{\tilde{R}_2} \supset y_{ij}^R (\bar{d}_{Ri} \tilde{R}_2 i\tau_2 L_j) + \text{h.c.}$$

- $\Delta F = 2$ imposes strict bounds :

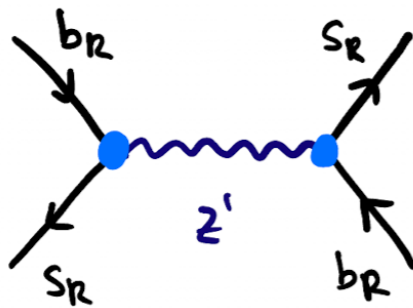

\Rightarrow Small coupling to quarks: $\frac{|g_{sb}^R|}{m_{Z'}} \lesssim 2 \times 10^{-3} \text{ TeV}^{-1}$

\Rightarrow Impossible to fit data with a perturbative coupling to τ 's for a heavy Z' .

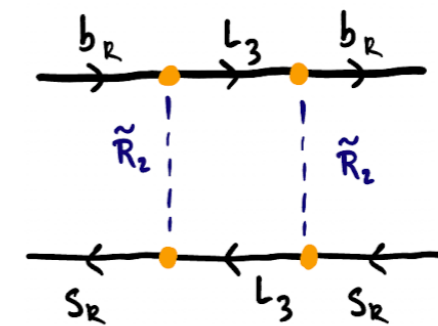

\Rightarrow Upper bound on LQ mass:

$$m_{\text{LQ}} \lesssim 3 \text{ TeV}$$

Difficult to accommodate such a large excess, but possible in certain models.

Left vs. Right-Handed Neutrinos

$$[\mathcal{O}_{lq}^{(1)}]_{\alpha\beta kl} = (\bar{L}_\alpha \gamma^\mu L_\beta) (\bar{Q}_k \gamma_\mu Q_l) ,$$

$$[\mathcal{O}_{lq}^{(3)}]_{\alpha\beta kl} = (\bar{L}_\alpha \gamma^\mu \tau^I L_\beta) (\bar{Q}_k \tau^I \gamma_\mu Q_l) ,$$

$$[\mathcal{O}_{ld}]_{\alpha\beta kl} = (\bar{L}_\alpha \gamma_\mu L_\beta) (\bar{d}_{kR} \gamma^\mu d_{lR}) ,$$

$$[\mathcal{O}_{Nq}]_{kl} = (\bar{N}_R \gamma^\mu N_R) (\bar{Q}_k \gamma_\mu Q_l) ,$$

$$[\mathcal{O}_{Nd}]_{kl} = (\bar{N}_R \gamma^\mu N_R) (\bar{d}_{kR} \gamma^\mu d_{lR}) ,$$

$$[\mathcal{O}_{lNqd}^S]_{\alpha kl} = (\bar{L}_\alpha N_R) \epsilon (\bar{Q}_k d_{lR}) ,$$

$$[\mathcal{O}_{lNqd}^T]_{\alpha kl} = (\bar{L}_\alpha \sigma_{\mu\nu} N_R) \epsilon (\bar{Q}_k \sigma^{\mu\nu} d_{lR}) ,$$

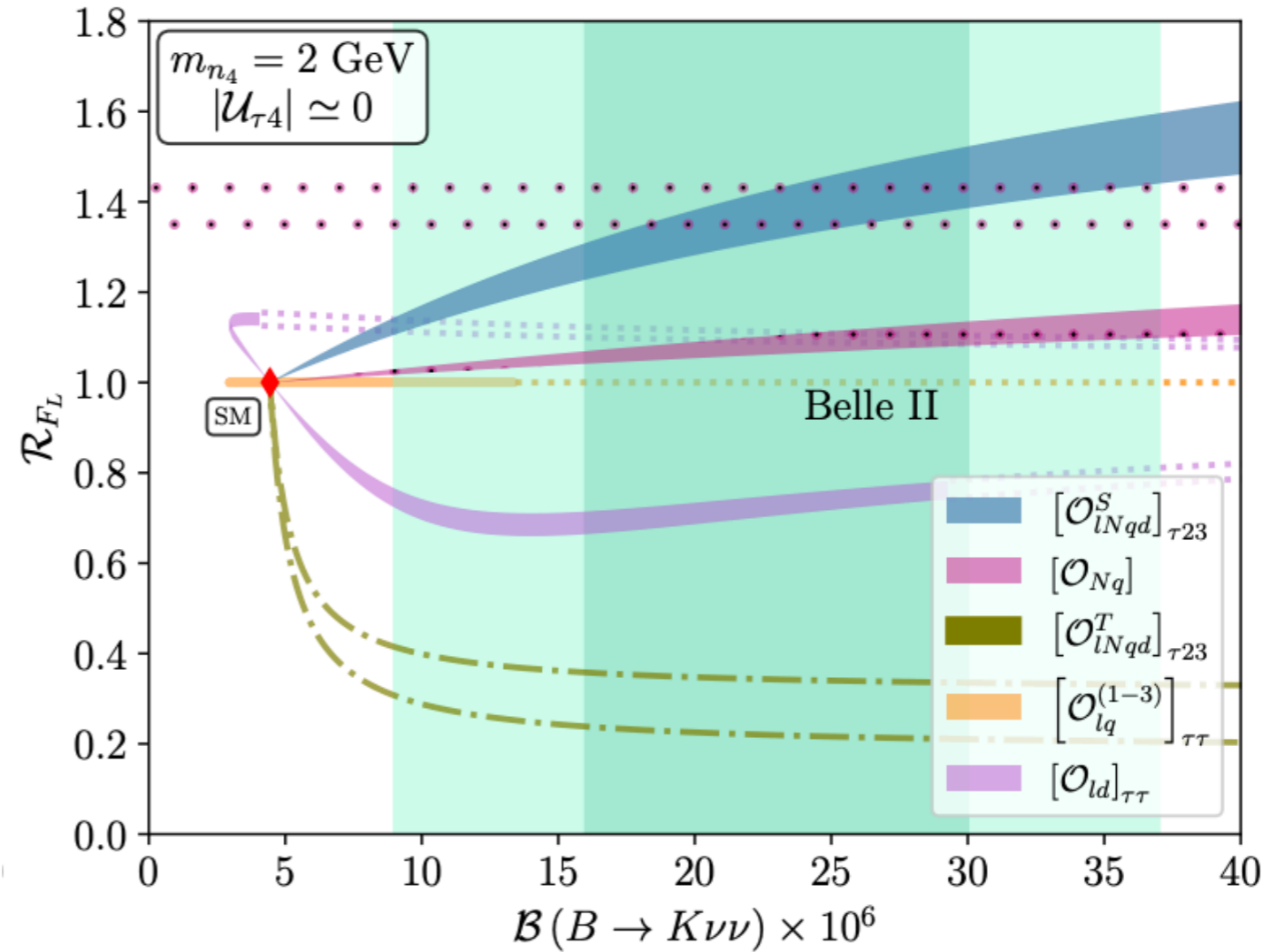

[Rosauro Alcaraz, Leal, 2404.17440]

LFU vs. single-flavor

[Allwicher, Becirevic, Piazza, Rousaro-Alcaraz OS. '23]

