

TESTBEAM PERFORMANCE OF ALTIROC3-LGAD HYBRID ASSEMBLIES FOR ATLAS HGTD

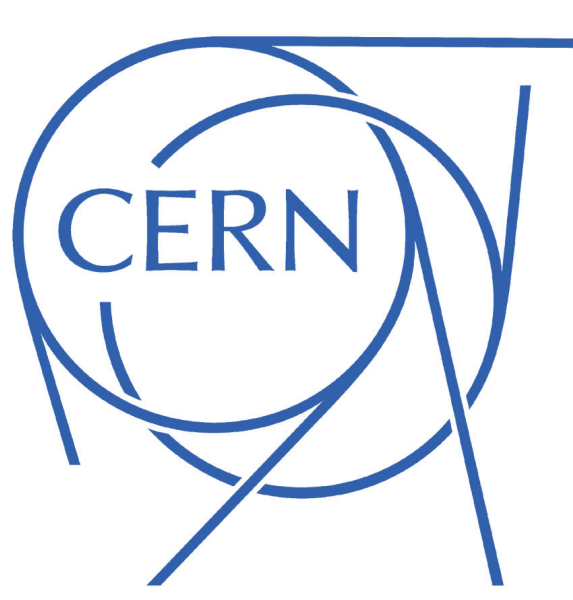

Xiao Yang (CERN, Geneva), on behalf of the ATLAS HGTD group
42nd ICHEP, Prague

1. INTRODUCTION

High-precision timing measurements can provide new handles to separate collisions that overlap spatially in the higher-luminosity environment. Both ATLAS and CMS are building new detectors for HL-LHC to provide this capability, and the High-Granularity Timing Detector^[1] for ATLAS aims to achieve 30-50 ps for charged-particle tracks at $2.4 < |\eta| < 4.0$, presenting challenges for both detector and readout electronics. A customized readout ASIC, ALTIROC^[3], has been developed to read out the low gain avalanche detector (LGAD). The latest version, ALTIROC3, which is expected to meet the requirements for functionality and radiation hardness and has been hybridised with the LGAD sensor and characterized with both charged-particle beams and the infrared laser Transient Current Technique (TCT) to evaluate its performance.

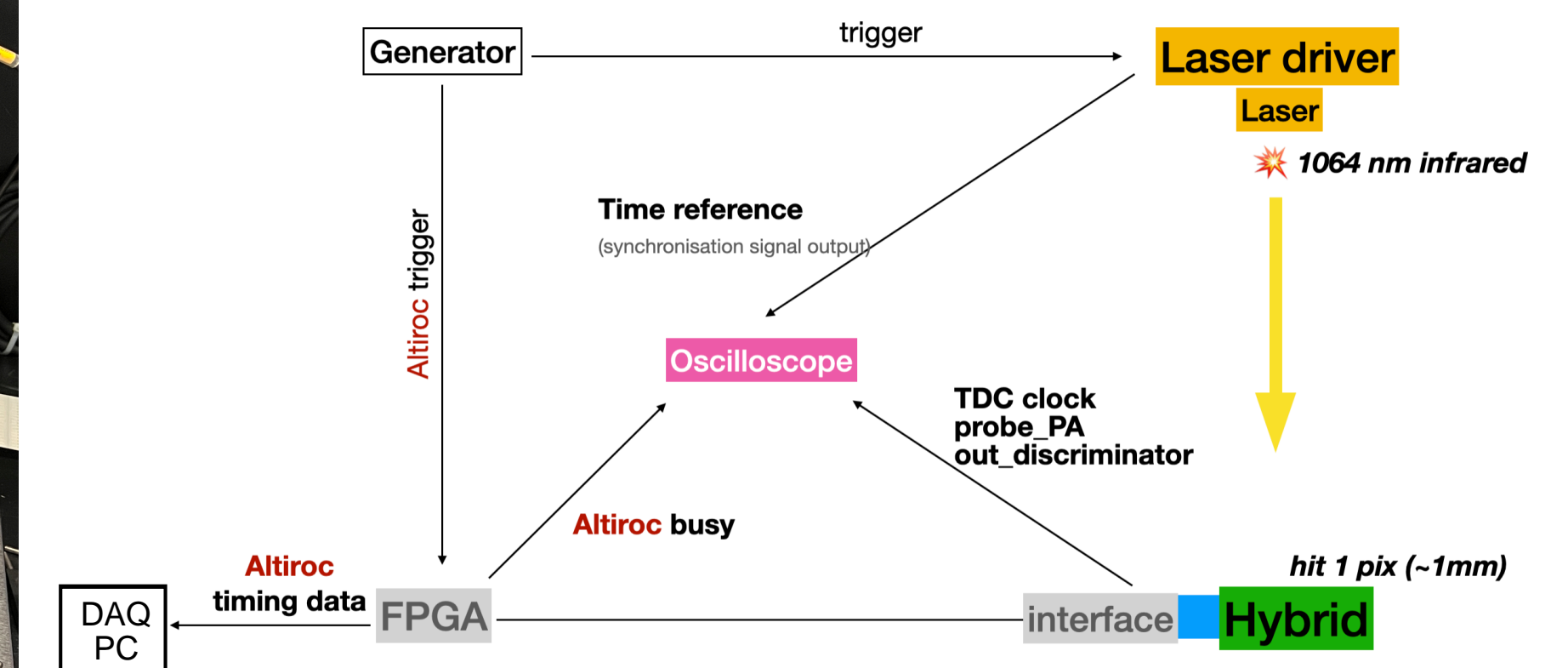
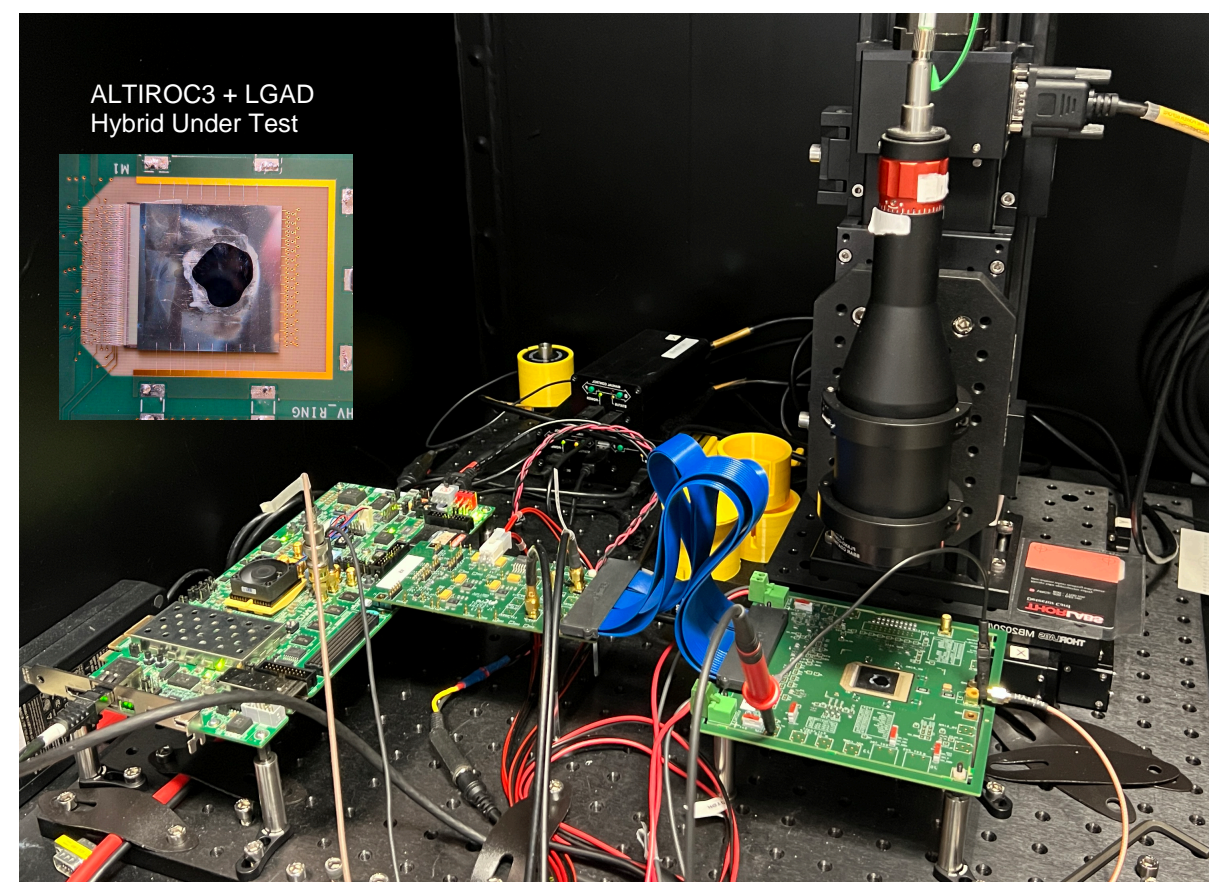
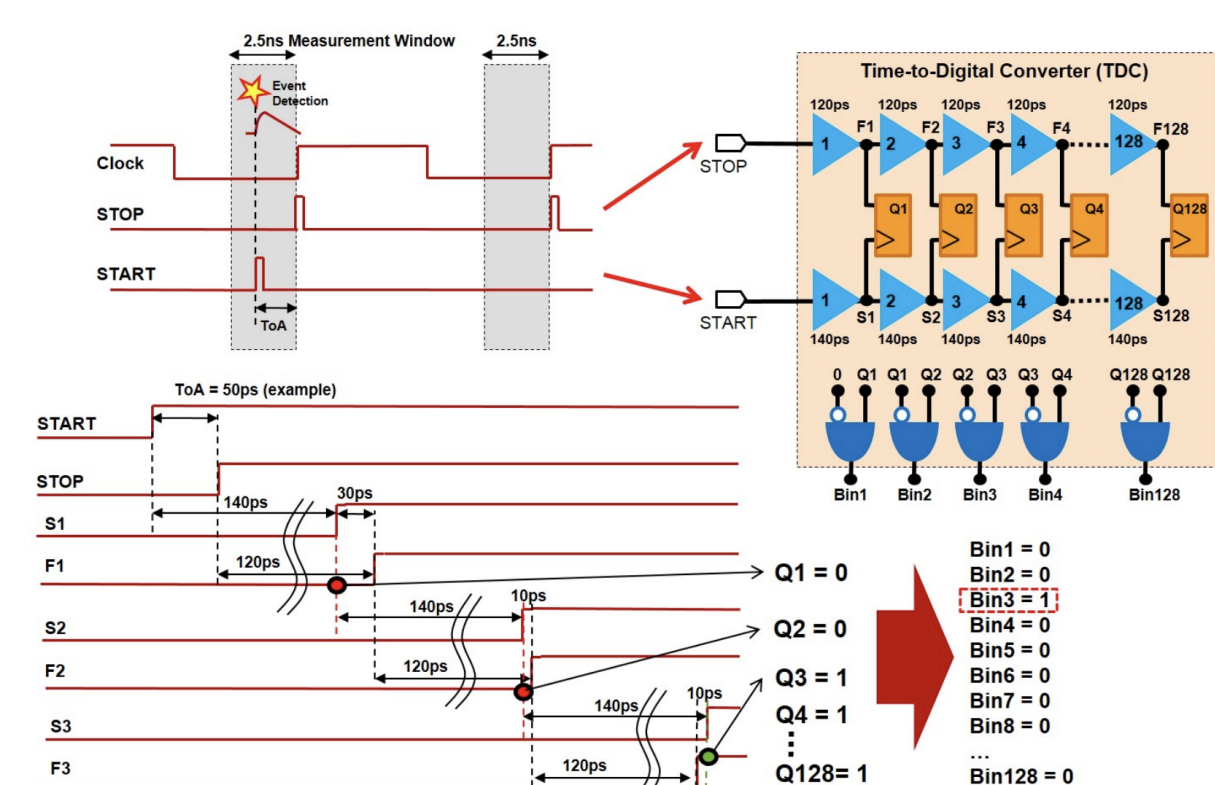
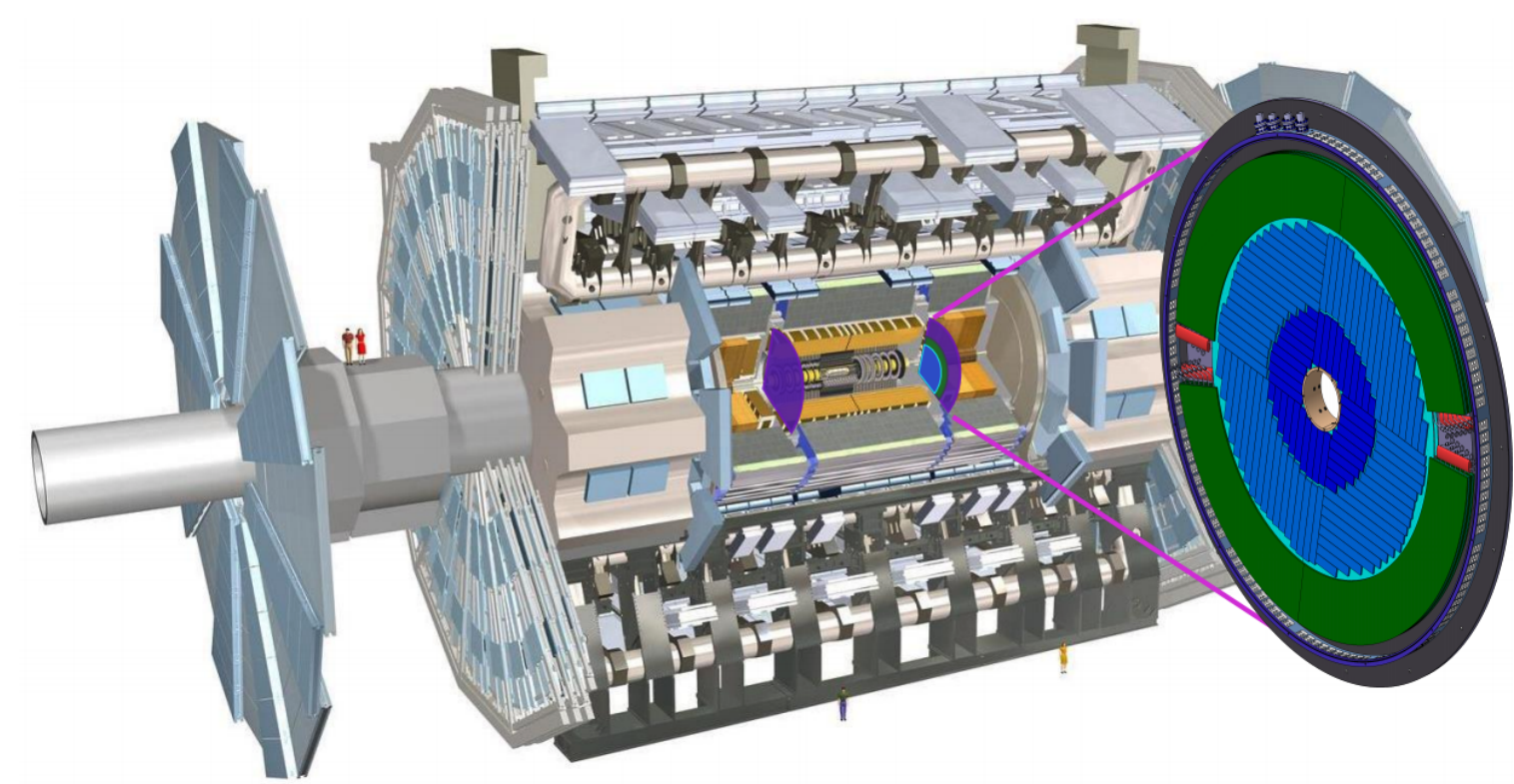

2. SETUPS FOR THE TESTBEAM

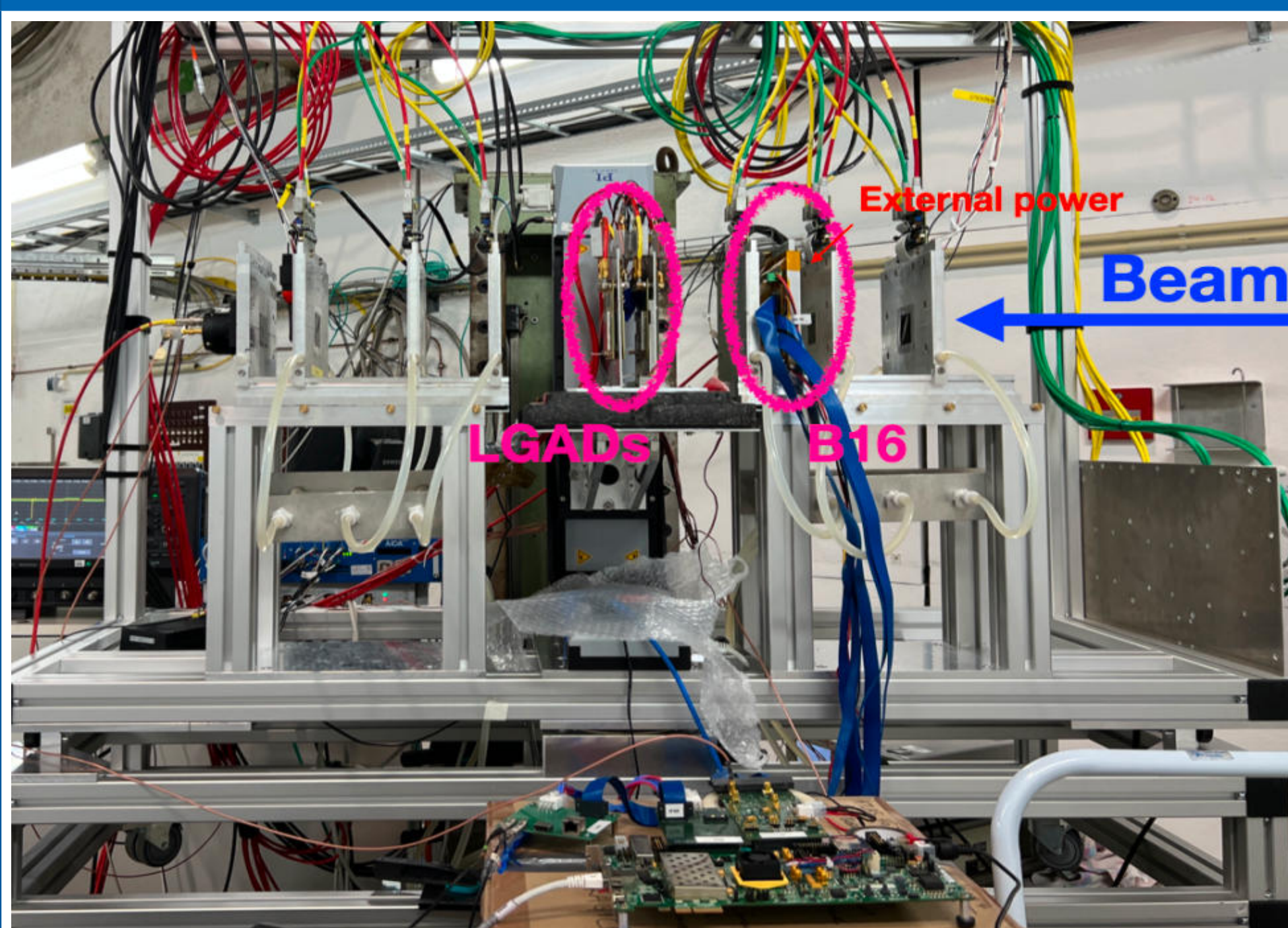

Tests of the ALTIROC3 hybrids were performed with the 1-6 GeV electrons/positrons beam at DESY II Test Beam Facility. The DATURA EUDET telescope equipped with six MIMOSA planes was used for tracking. An FEI4 detector was used to utilize the ROI for triggering the readout. An AIDA-Trigger Logic Unit (TLU) was used to distribute the synchronized triggers to DUT and Telescope with pre-defined logic. The ALTIROC3 was assembled to a test PCB which was readout by an FPGA with AIVin software and firmware deployed. The outputs of the front-end amplifier and the TDC clock are also probed by a 1 GHz digitizer at 6.25 GS/s rate.

3. TEST-BENCH CALIBRATION

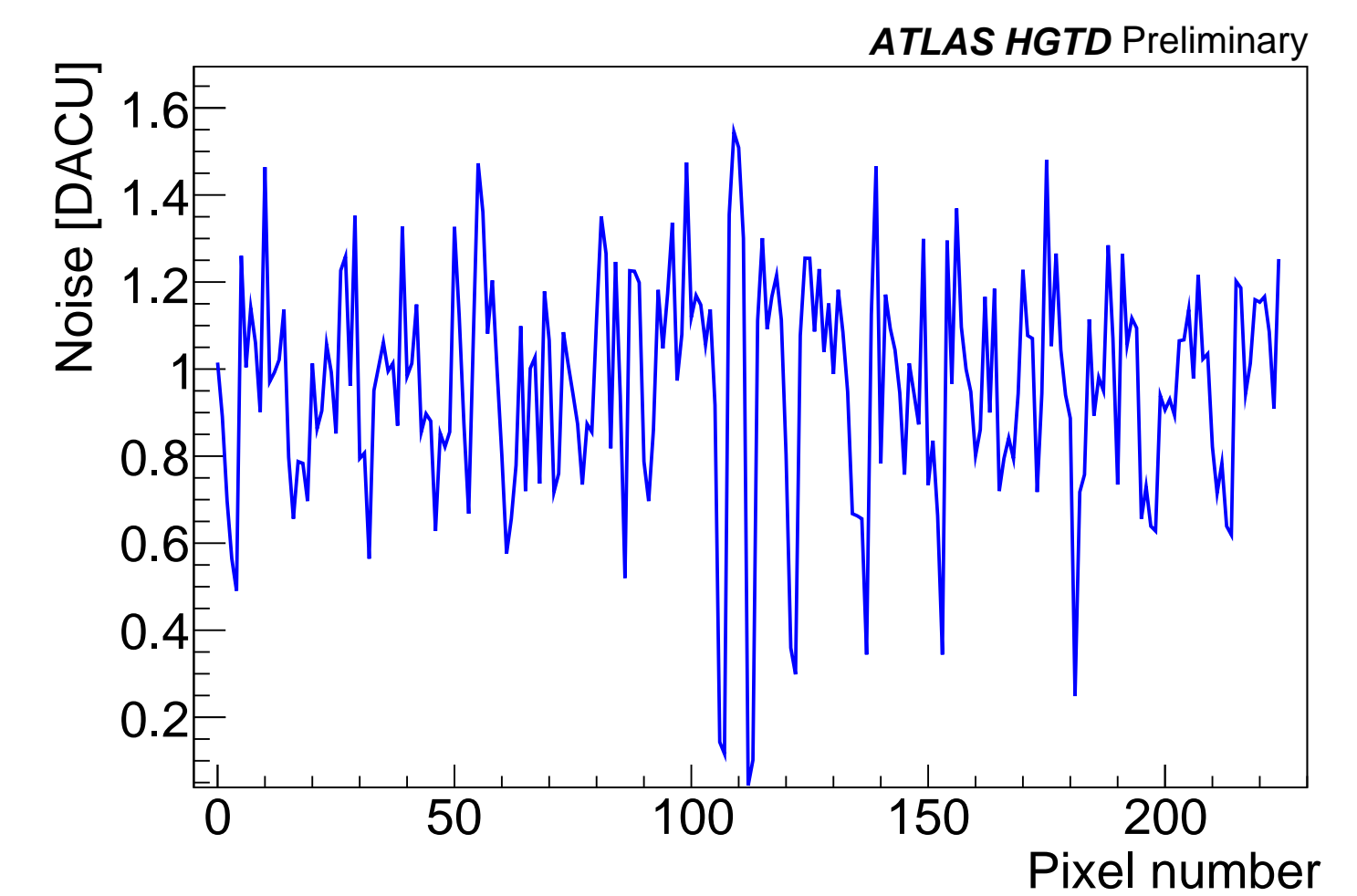
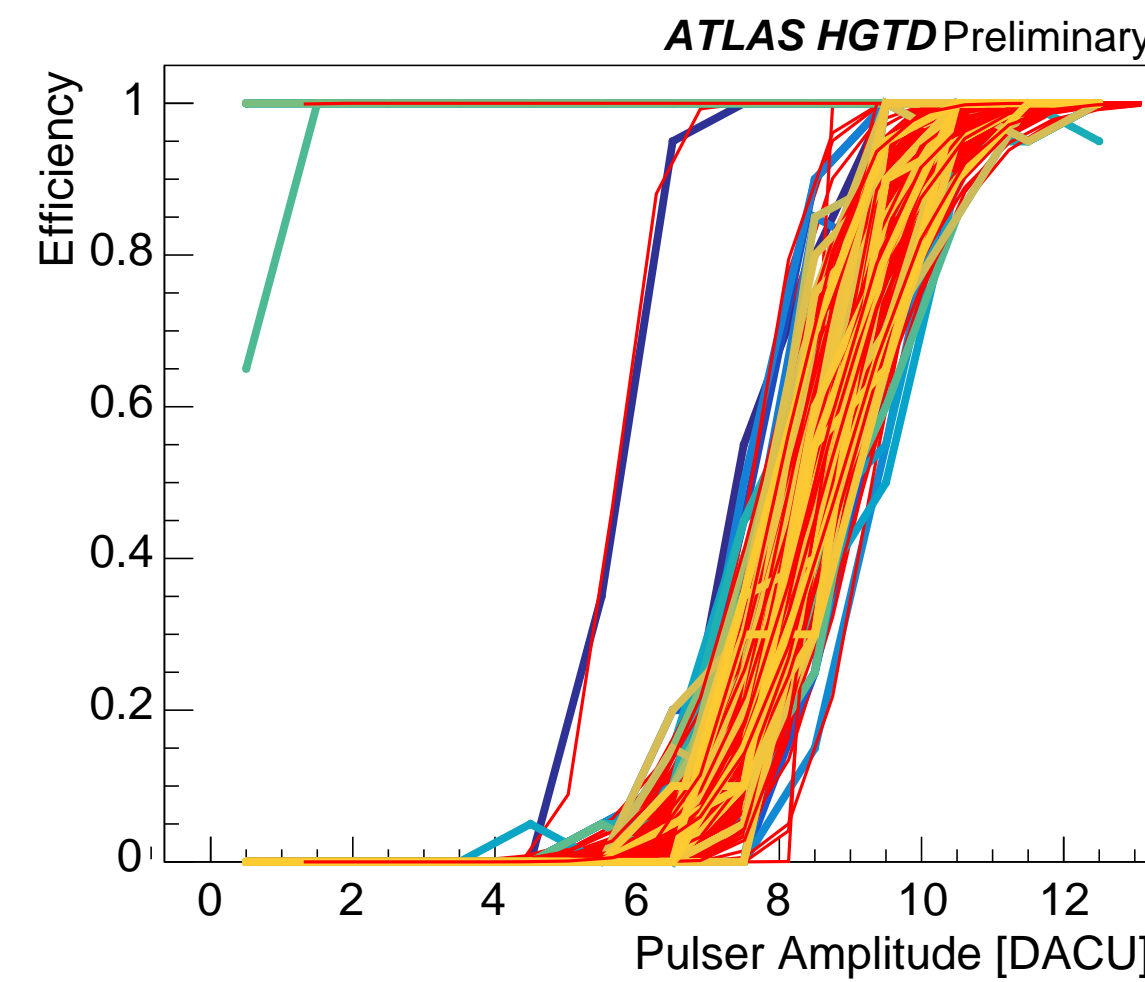
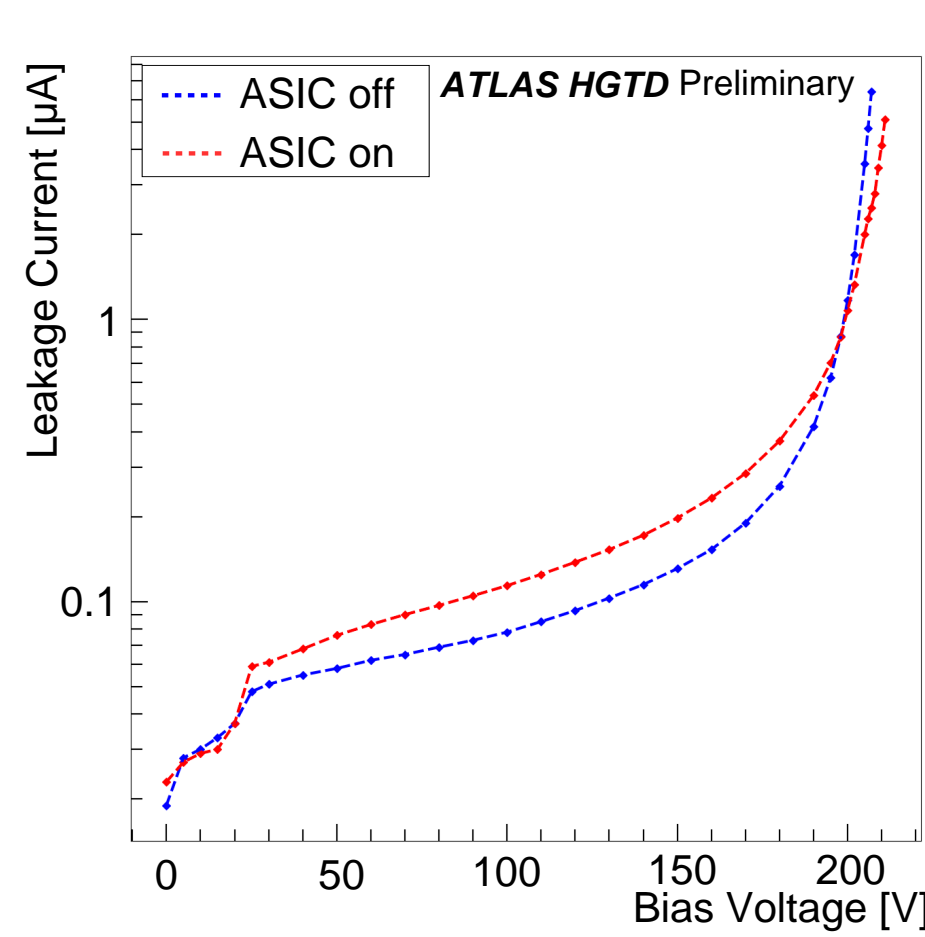

Before the measurement, the I-V curve of the hybrid was measured with ASIC switched on and off to estimate the effect of temperature change on the sensor. The electronic calibrations were performed by the on-chip injection system and the per-pixel discriminator thresholds were tuned to have a uniform response to the injections with same amplitude to compensate performance variation. The noise was also obtained during the tuning. The post-tuning results are shown as the S-curves of each channel in the middle figure.

4. TIMING REFERENCE AND TIME-WALK CORRECTION

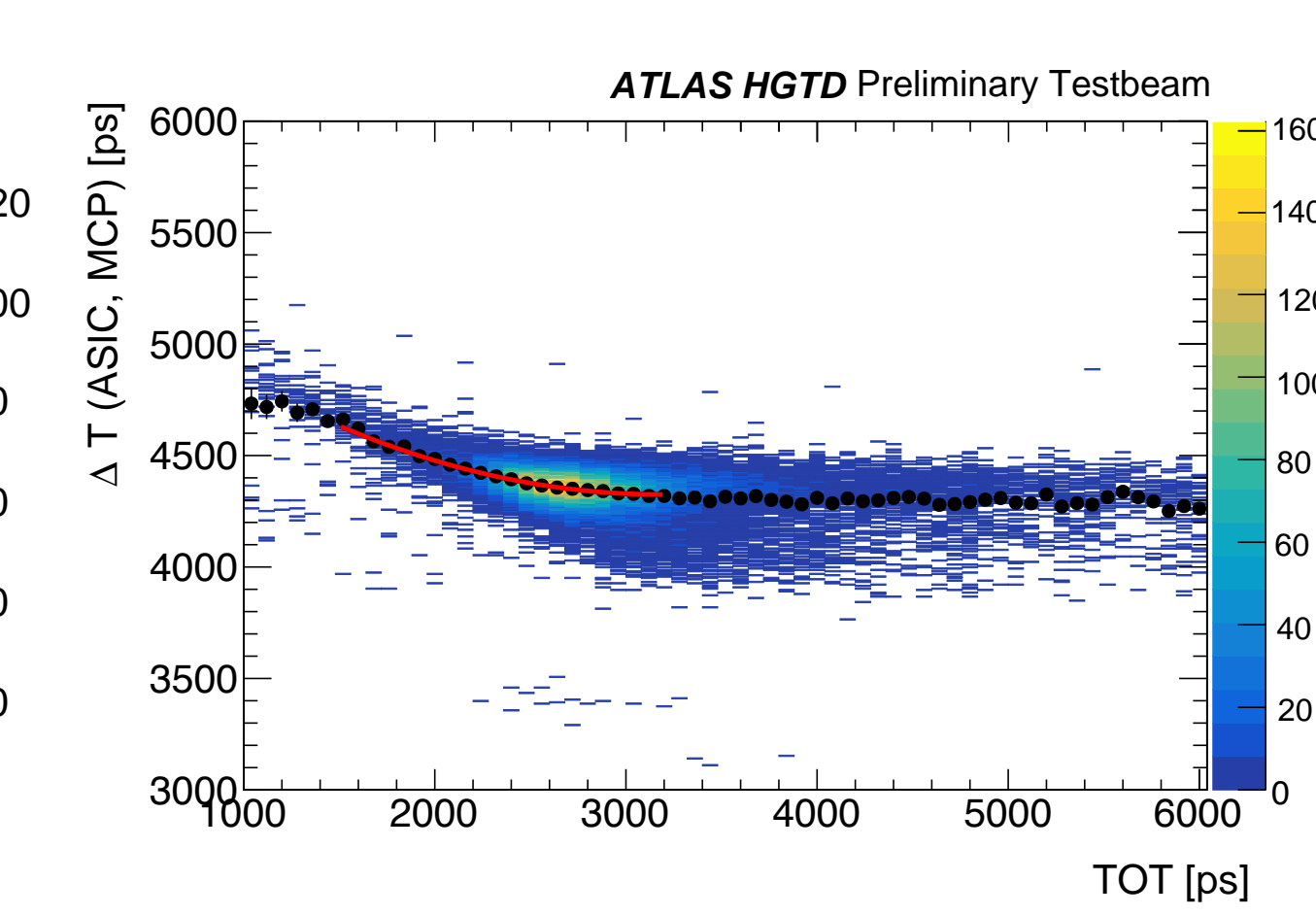
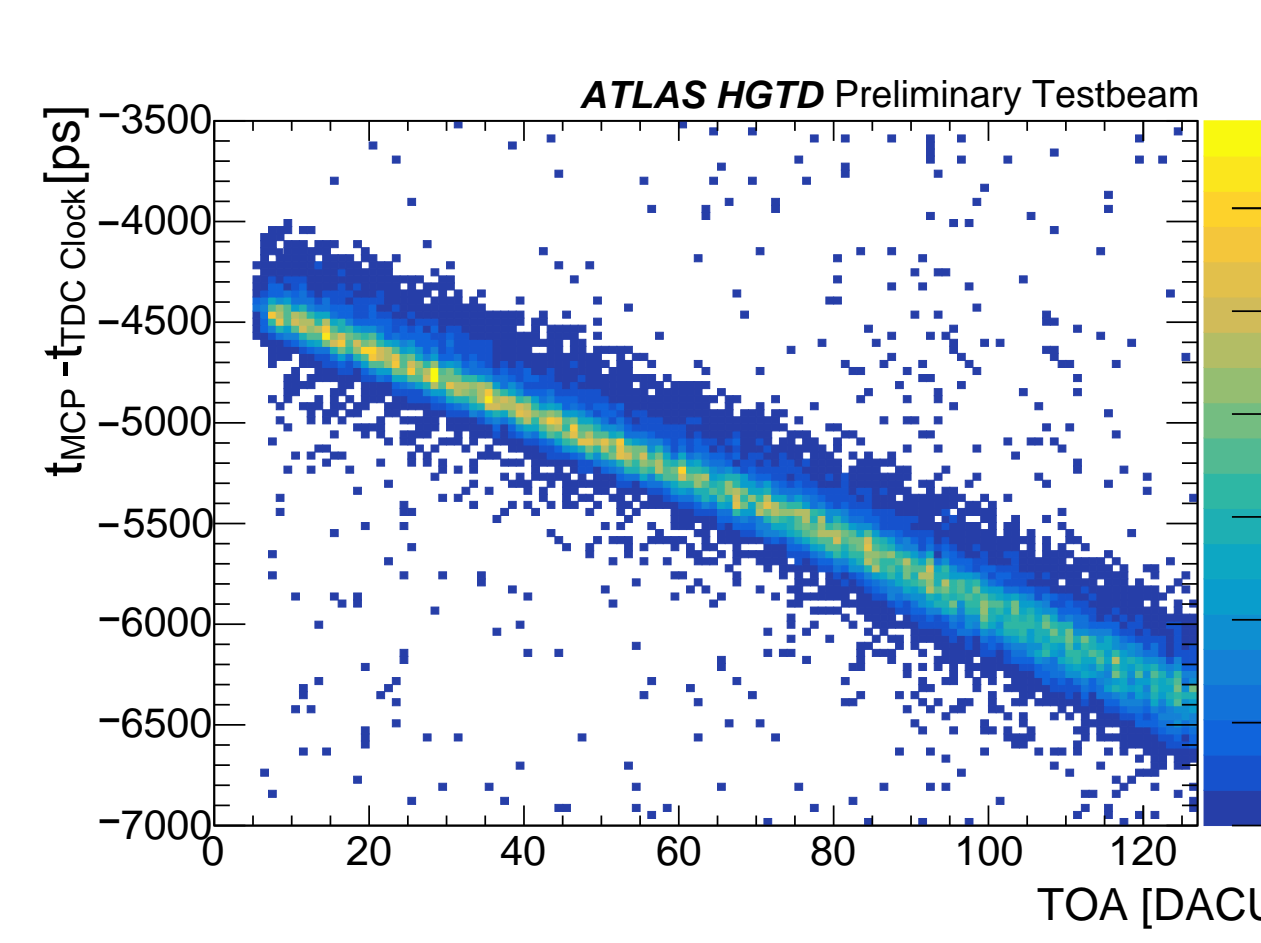
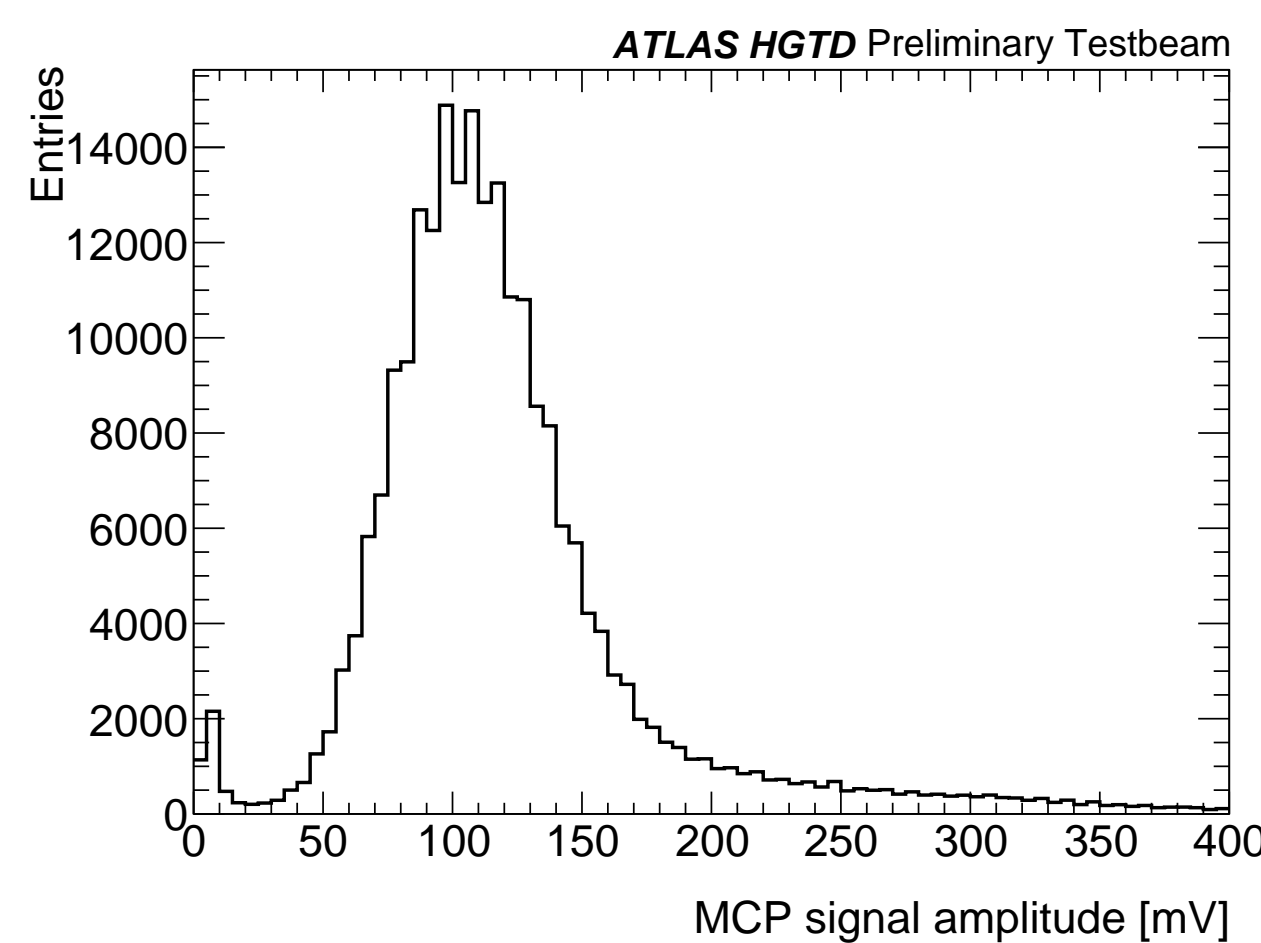

A dedicated MCP detector with ~ 10 ps resolution and 100 mV most probable amplitude at 2.6 kV was used as a timing reference. The TDC clock was sent to the digitiser to synchronize MCP with ASIC data. The correlation between the $t_{MCP} - t_{TDC\text{Clock}}$ and the TOA readout by the ALTIROC is shown. A good correlation is observed between the MCP time difference and the TOA, which indicates a correct measurements from the TDC. The slope of the correlation was extracted as the average LSB. To achieve a good timing precision, a time-walk correction is applied with the time-over-threshold measured by the TOT-TDC as the right plot shows.

5. PERFORMANCE EXTRACTION

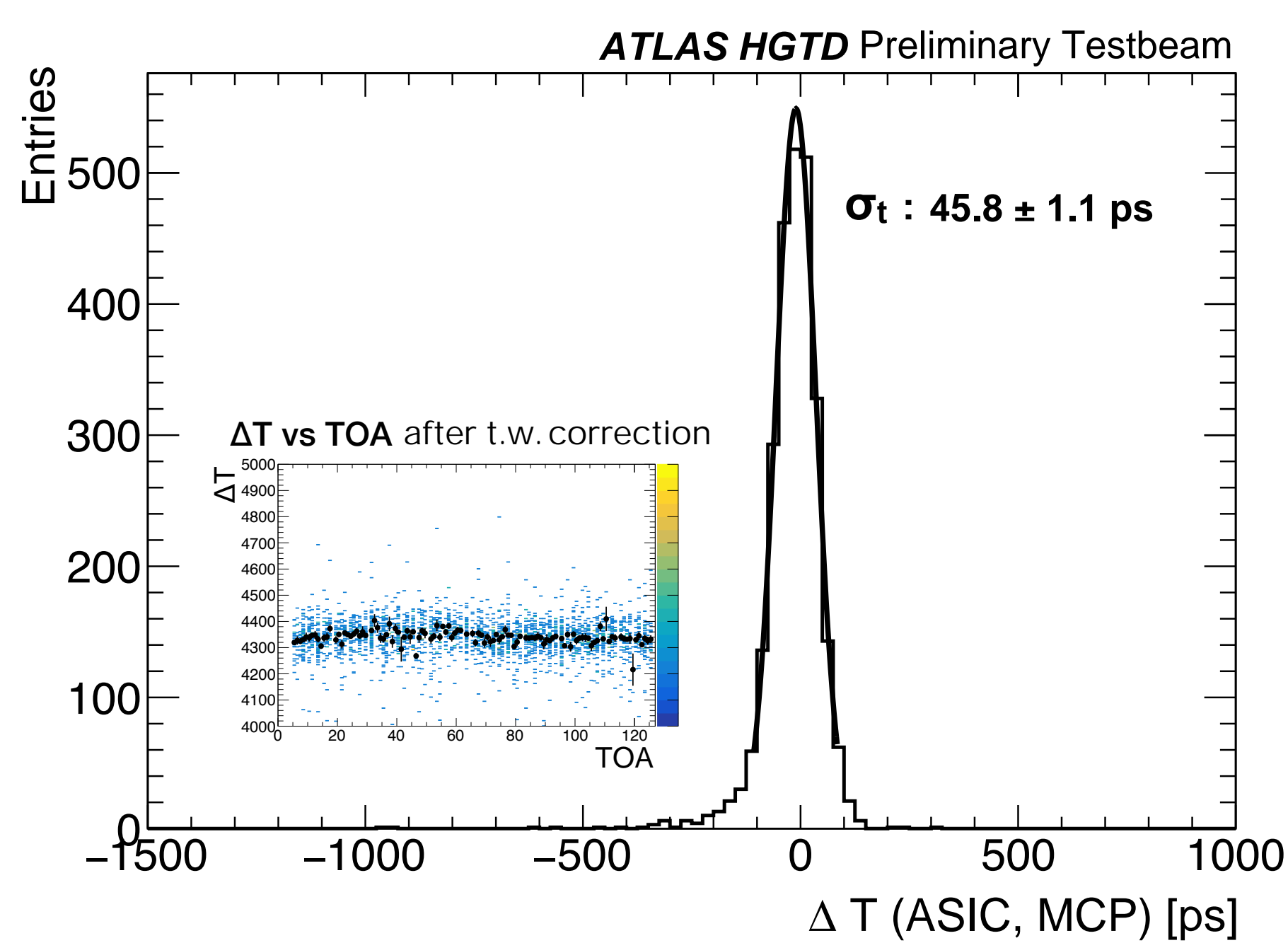

After the LSB was estimated with the MCP reference and the time-walk correction being applied, the time difference distribution was generated and a gaussian fitting was performed. As shown in the figure, the time resolution of 45.8 ps for the pixel of interest in the middle of the array (row 7, column 7) is obtained. The linearity of the TOA LSB is verified by the inset plot.

6. CONCLUSIONS

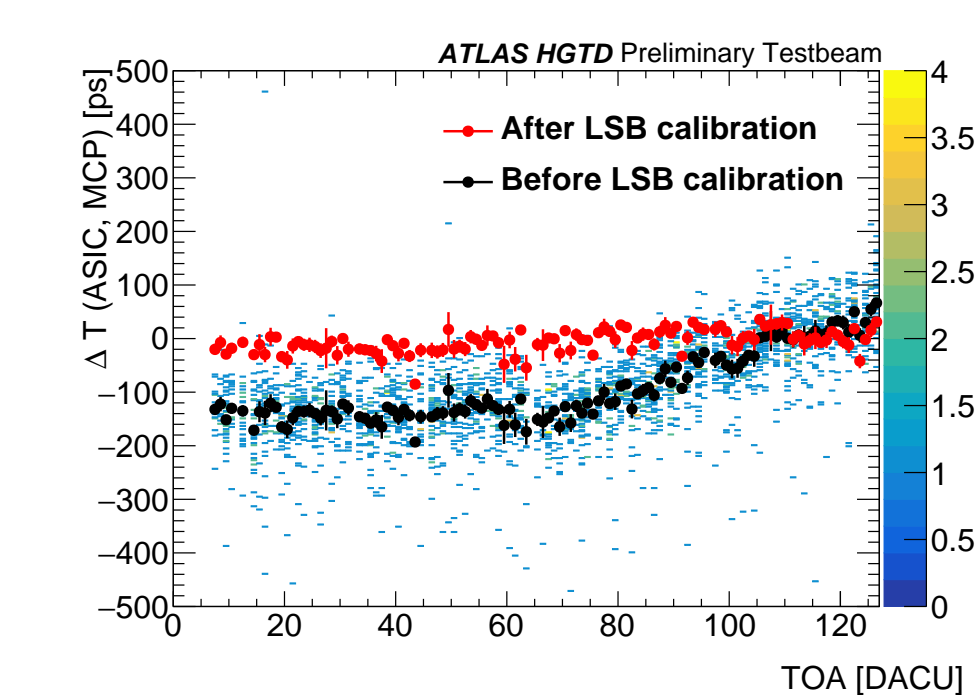
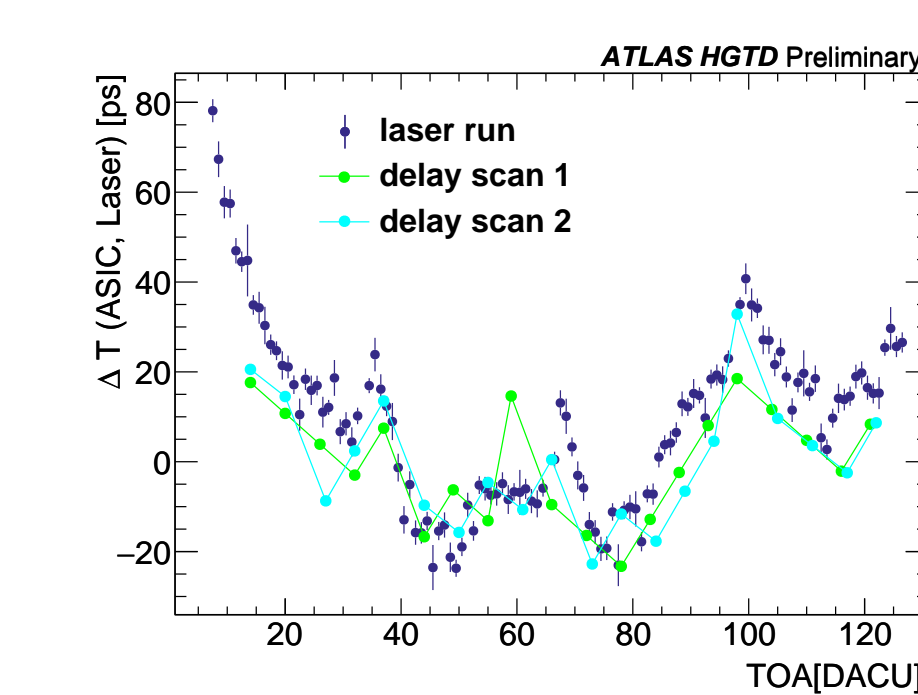
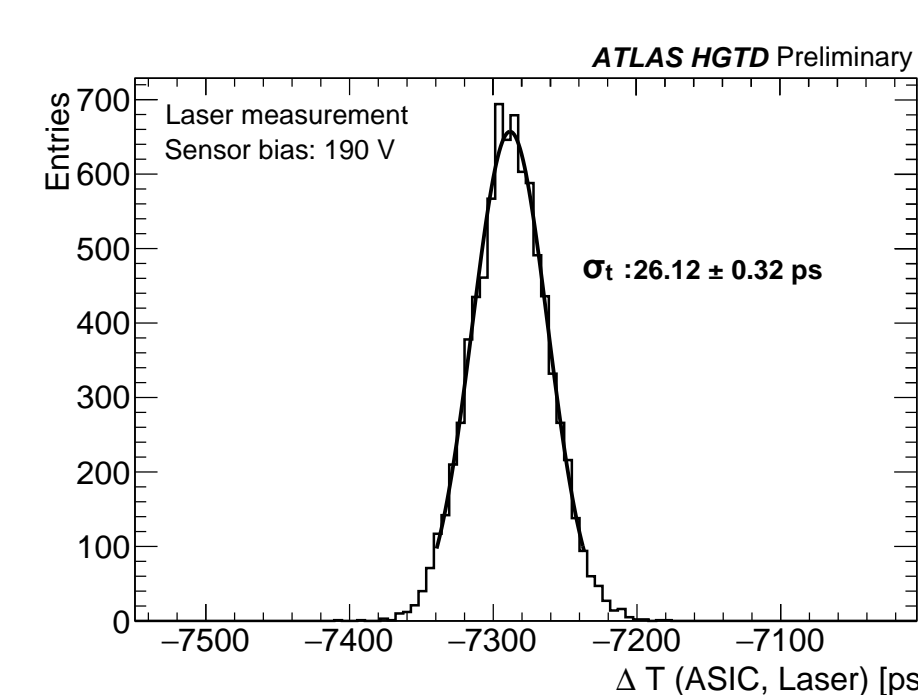
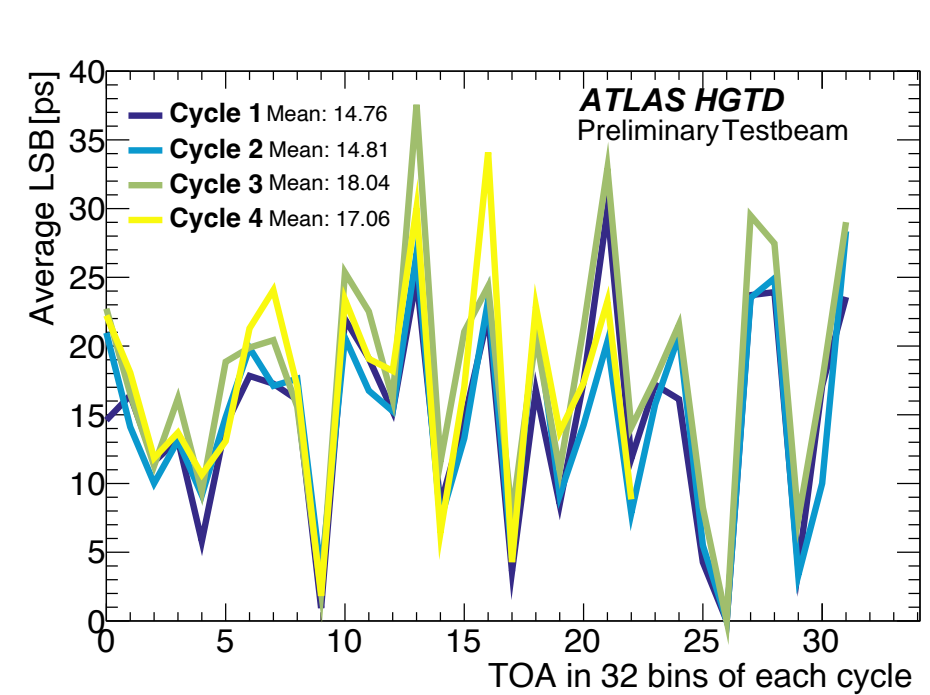

The linearity of the ALTIROC3 TDC was checked both with the reference and the delay scan was performed with the internal injection where the clock phase was shifted with a step of 97 ps. The measured timing difference variation with the delay scan was compared with the TCT data and a good agreement was observed, which means the differential non-linearity of the TDC LSB can be measured and corrected with the internal scan. A time resolution around 45 ps was achieved for the middle pixel. The differential non-linearity of the TOA TDC was measured as well with the testbeam data within the TDC cycle. The ALTIROC3 performance was further validated with the TCT setup and a 26.1 ps jitter was obtained, indicating a good performance of the TDC. Further tests would be useful to understand the contributions and to further improve the performance of the production design.

[1] HGTD TDR: ATLAS-TDR-031 <https://cds.cern.ch/record/2719855>

[2] AIVin: ALTIROC2 Visual Interface : <https://gitlab.cern.ch/ifaepix/alvin/>

[3] C. Agapopoulou et al 2023 JINST 18 P08019 Performance of a front-end prototype ASIC for the ATLAS High Granularity timing detector