

SpaCal — Light guide optimisation

Model of SpaCal

All materials properties was set same as in MyMaterial.cc in HybridMC

- Absorber — Pb — xy sizes — 30.25x30.25 mm; z — 30 cm;
- 11x11 fibres — Polystyrene core (without impurities) & PMMA cladding (without impurities) — in xy; radius—1 mm core + 0.03 mm cladding;
- SiPM-PMT — z — 0.4 mm;
- Mirror — reflective index 1.0 — 80% +- 10%

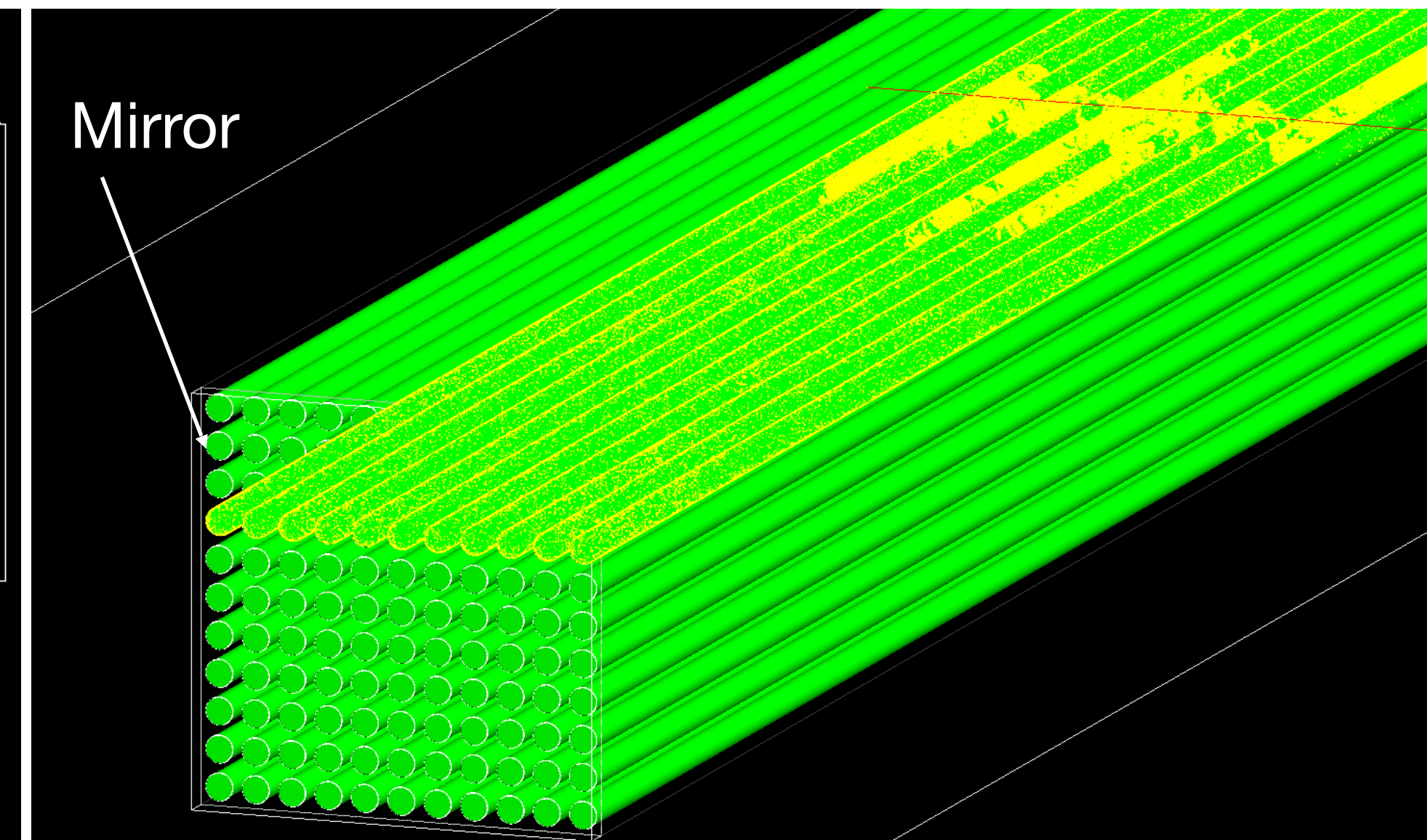
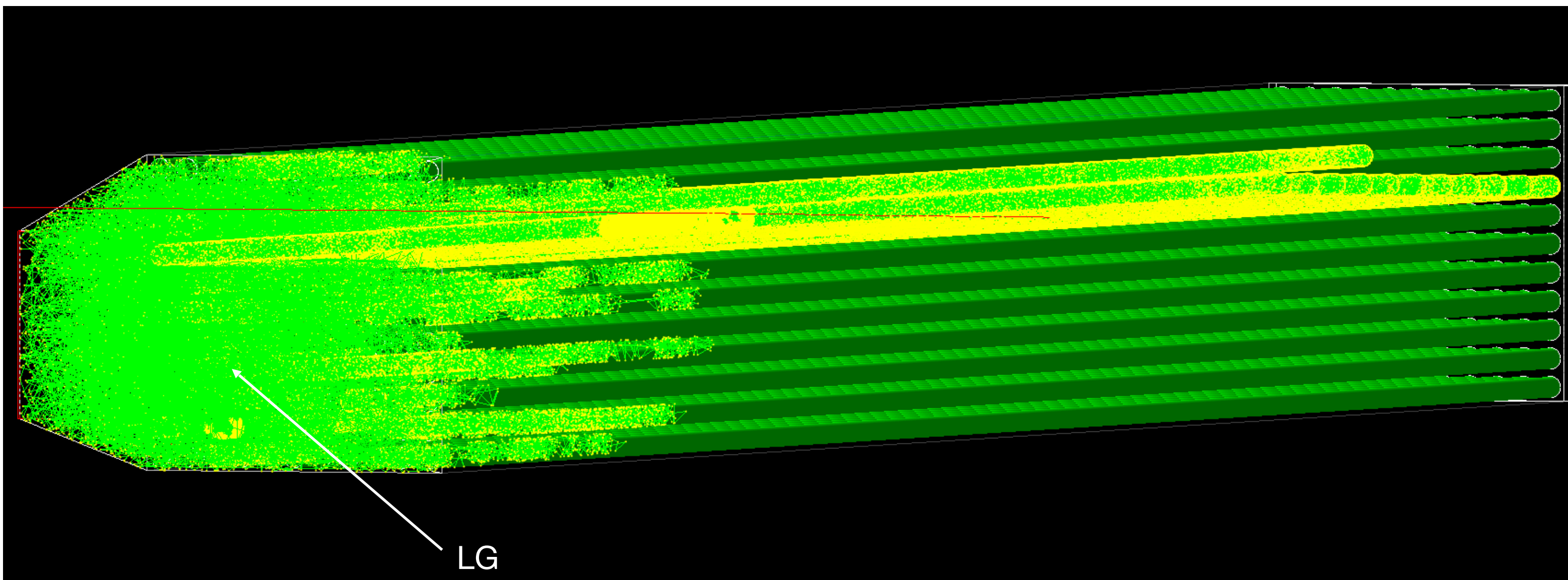
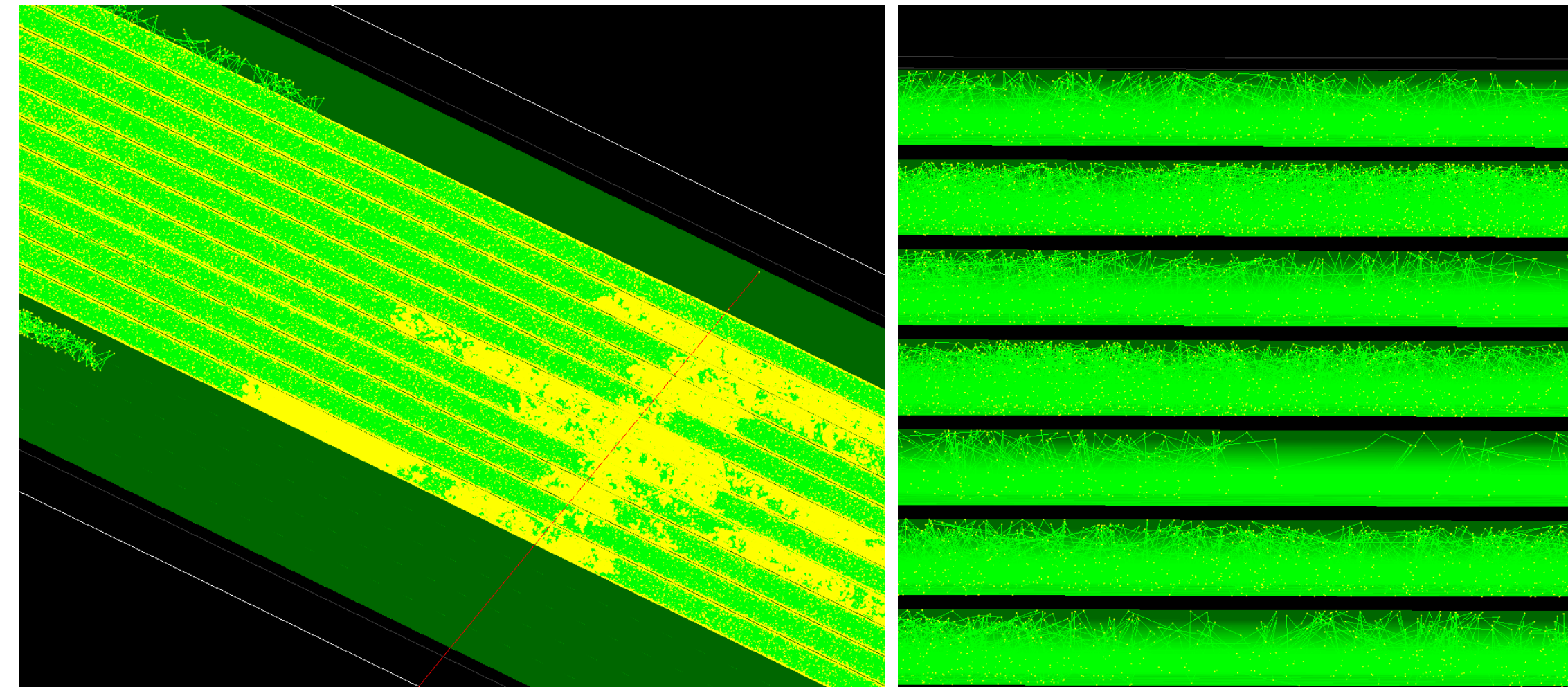

Geometry configurations

- Geometry 1.1

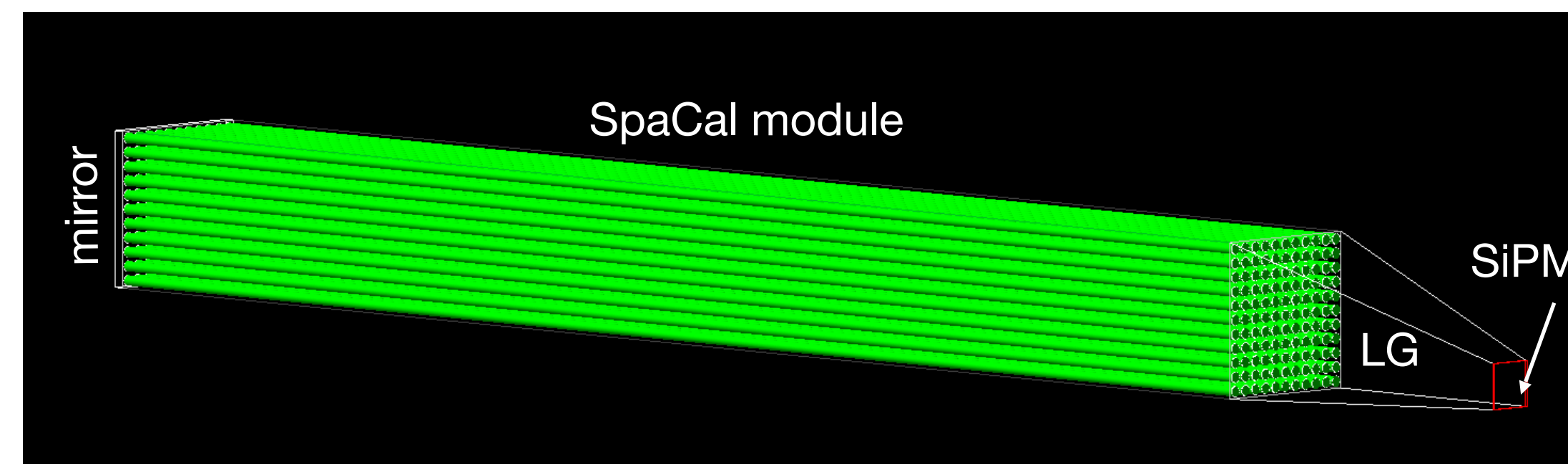
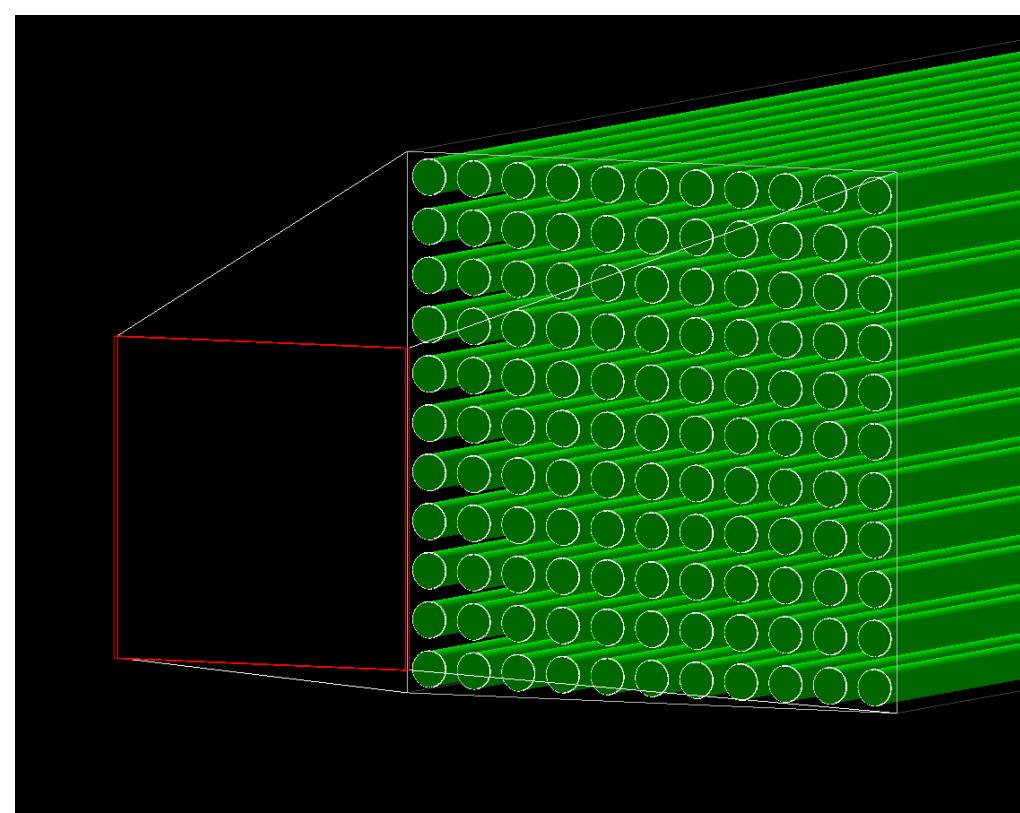
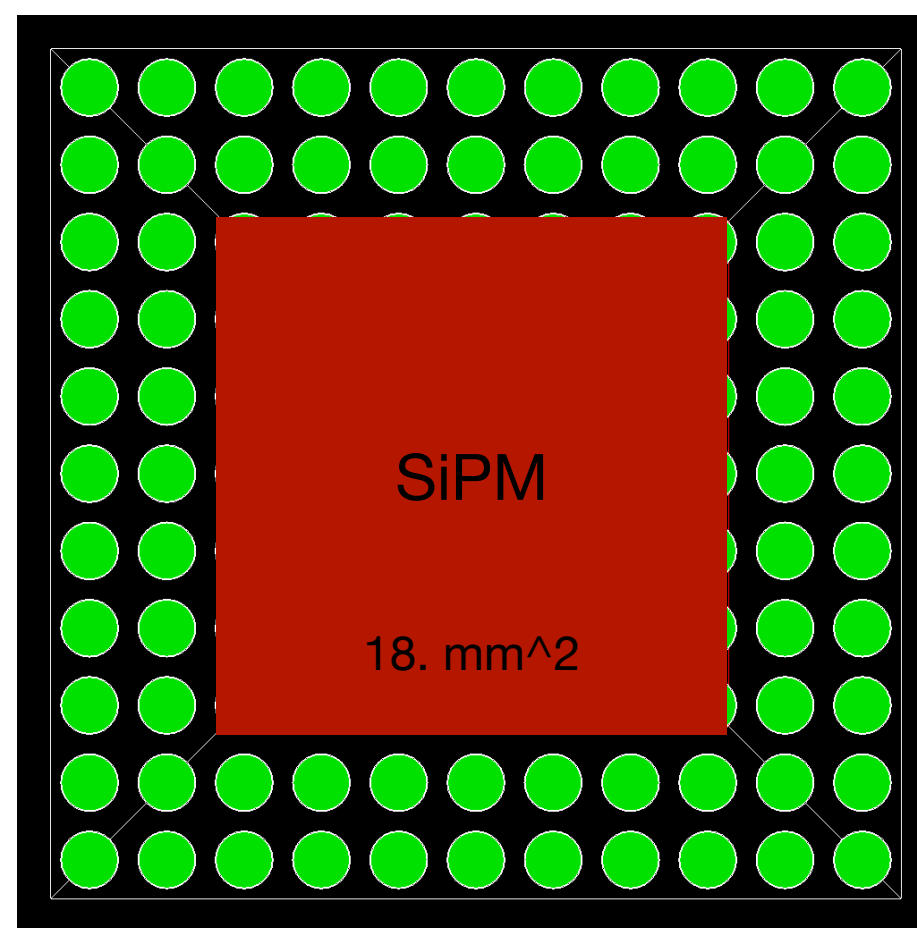

- Geometry 1.2

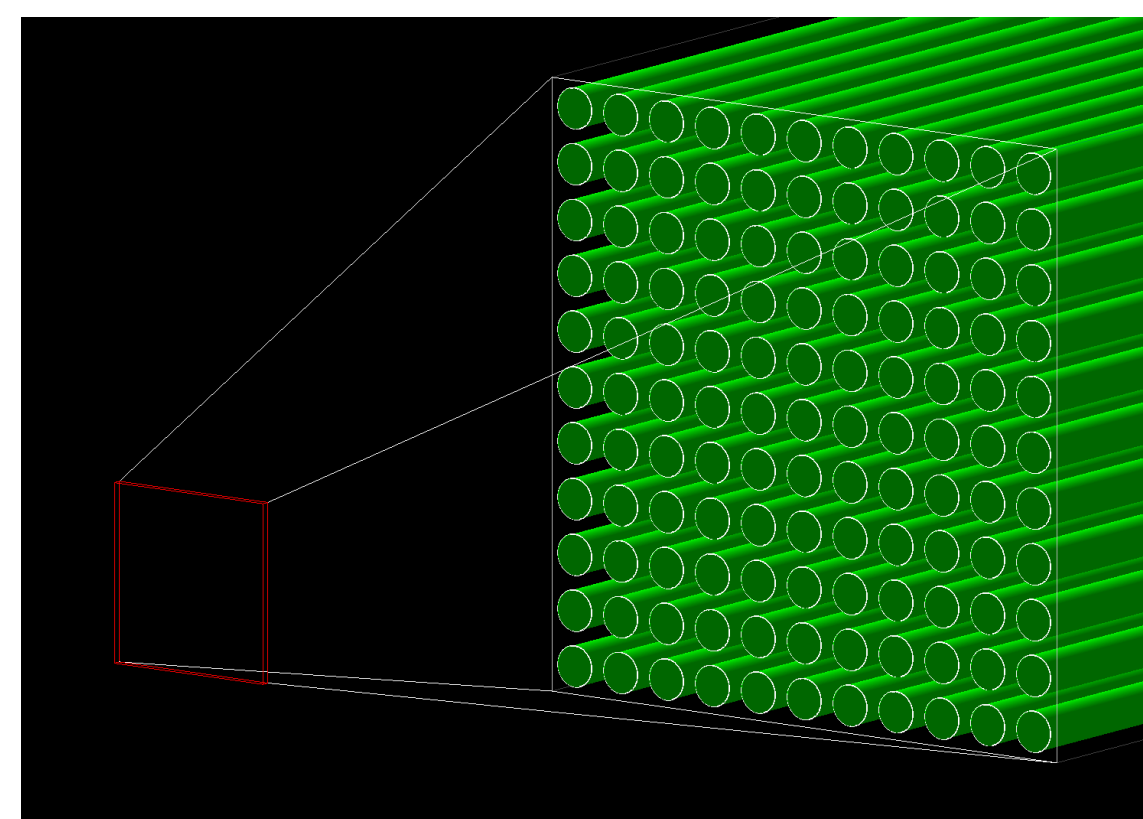
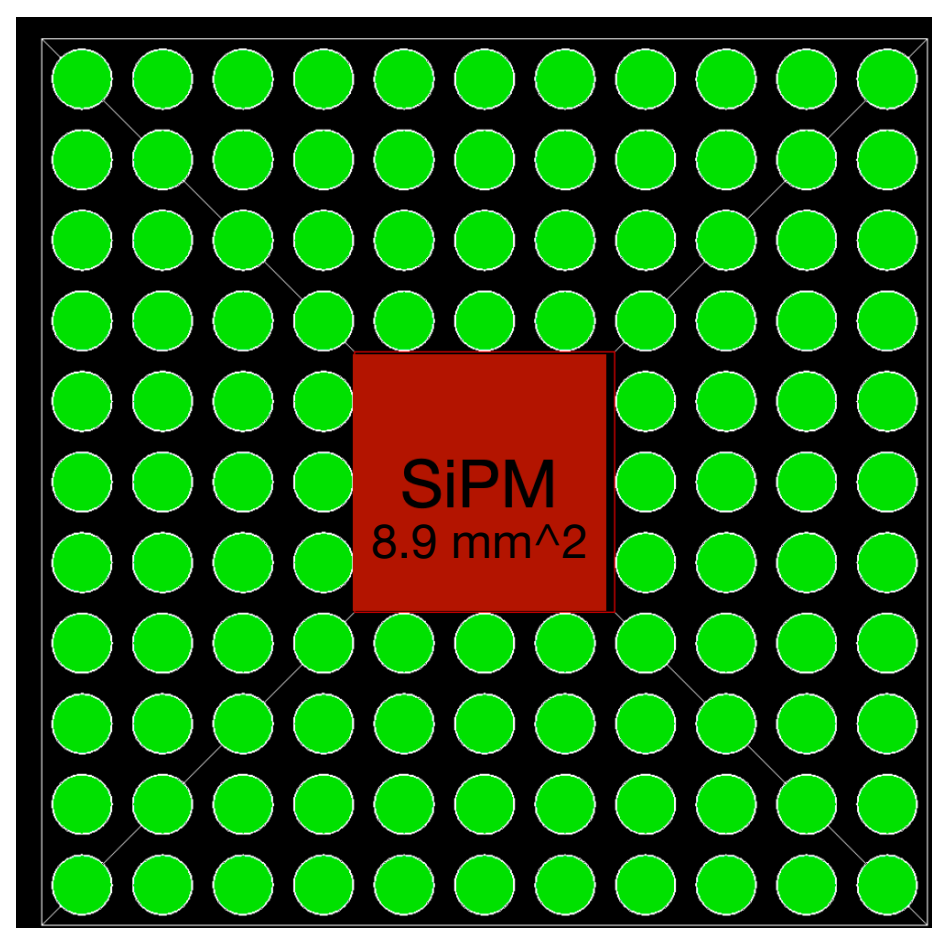

- Geometry 1.3 no results for now

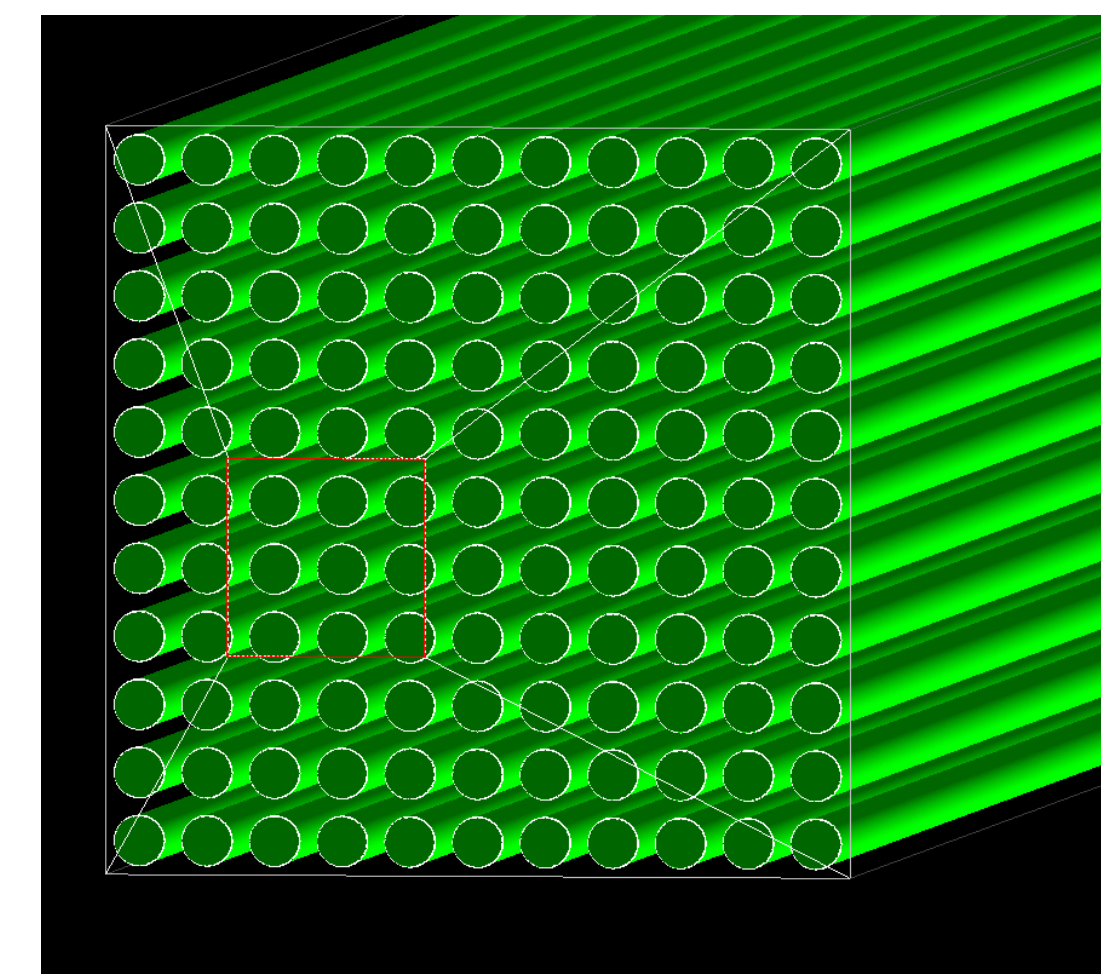
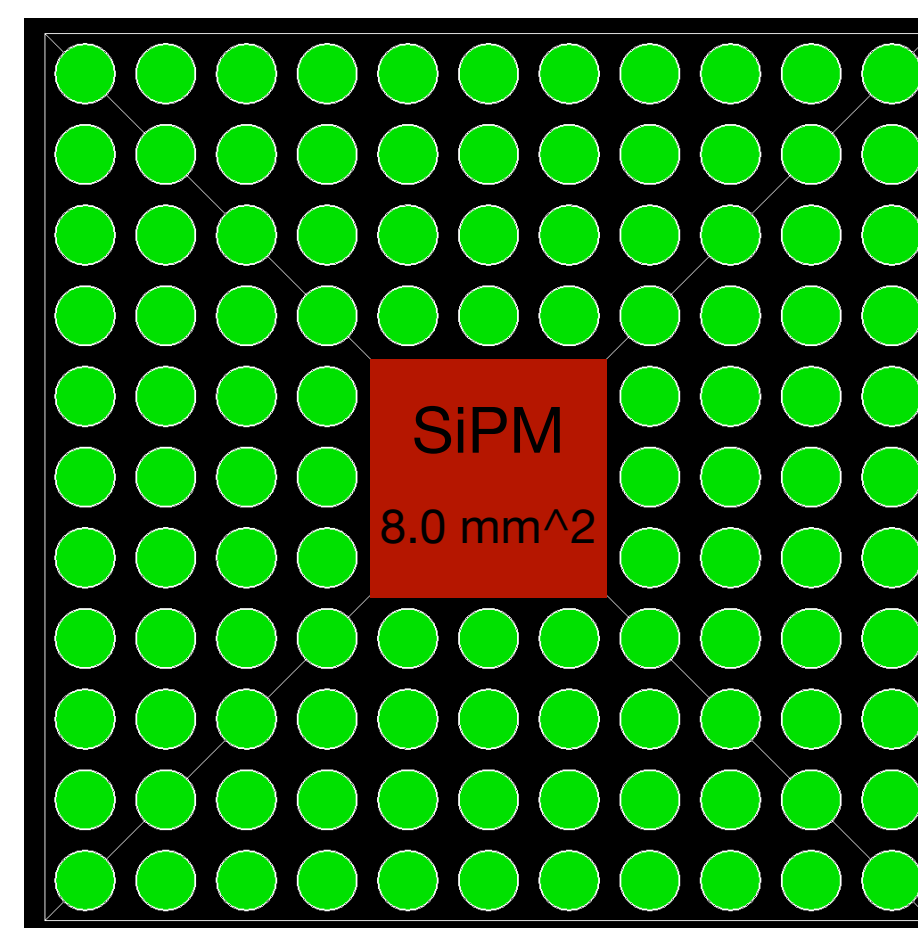

Geometry configurations

- Geometry 2

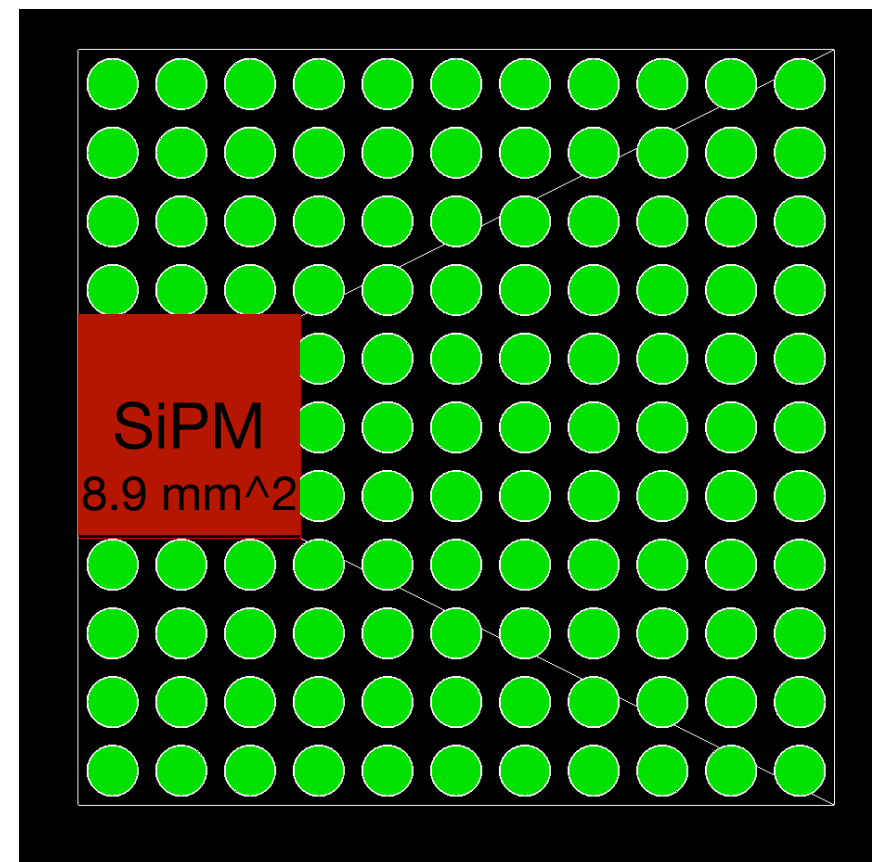
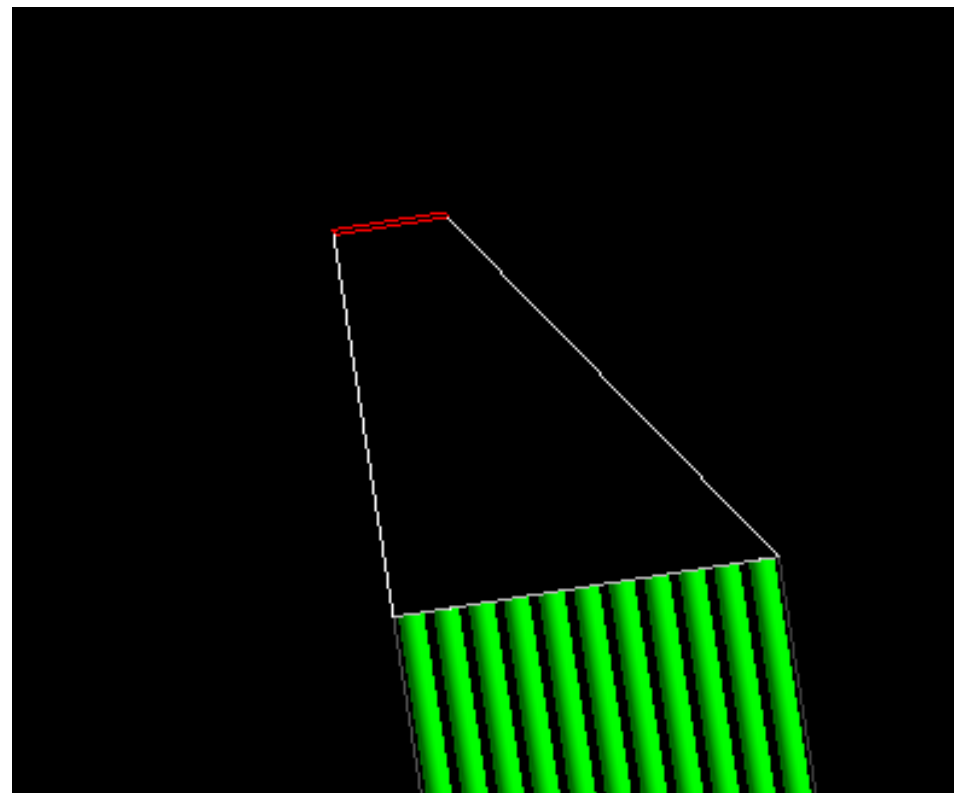

- Geometry 3

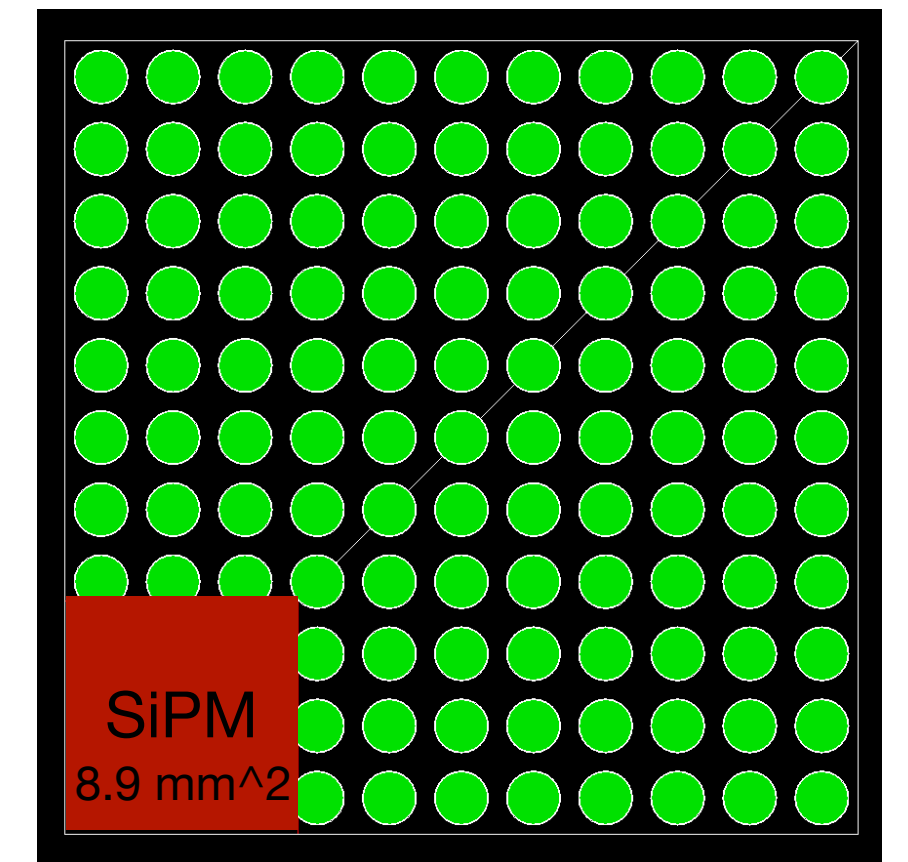
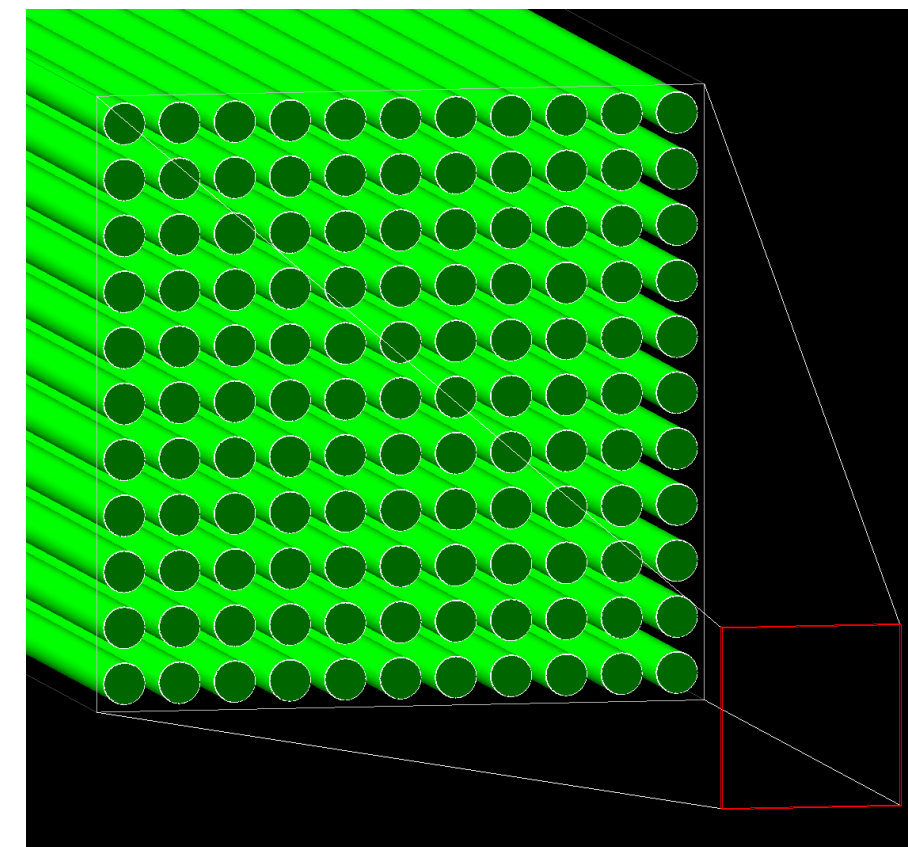

Geometry configurations

• Geometry 4

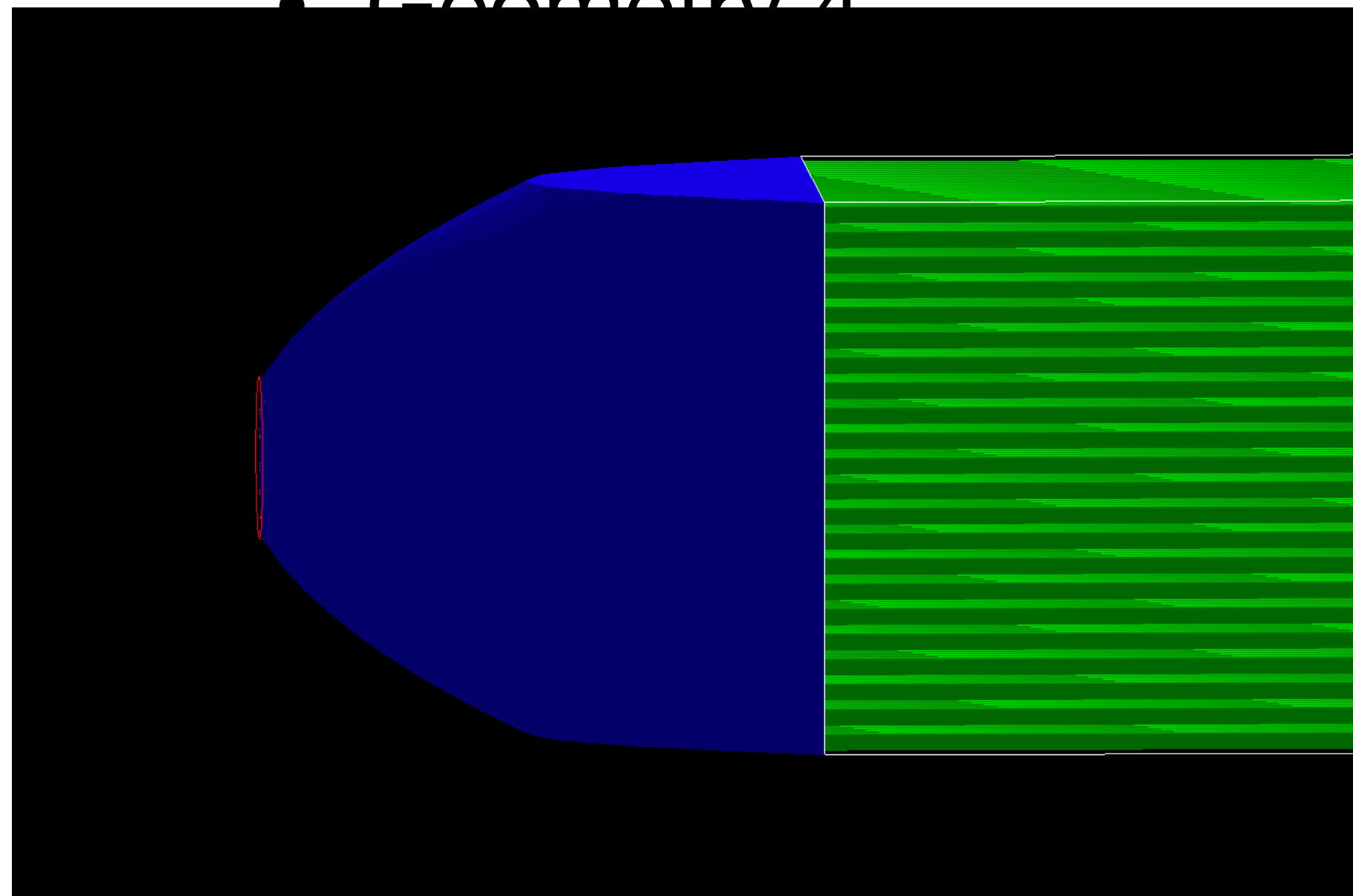

Winston Cone

```
G4VSolid* coneS = new G4Paraboloid  
("aPara", 0.5*PLEX_depth,PMT_radius,  
0.5*sqrt(2)*(lguide_edge-2.0*airGap));
```

• Geometry 5

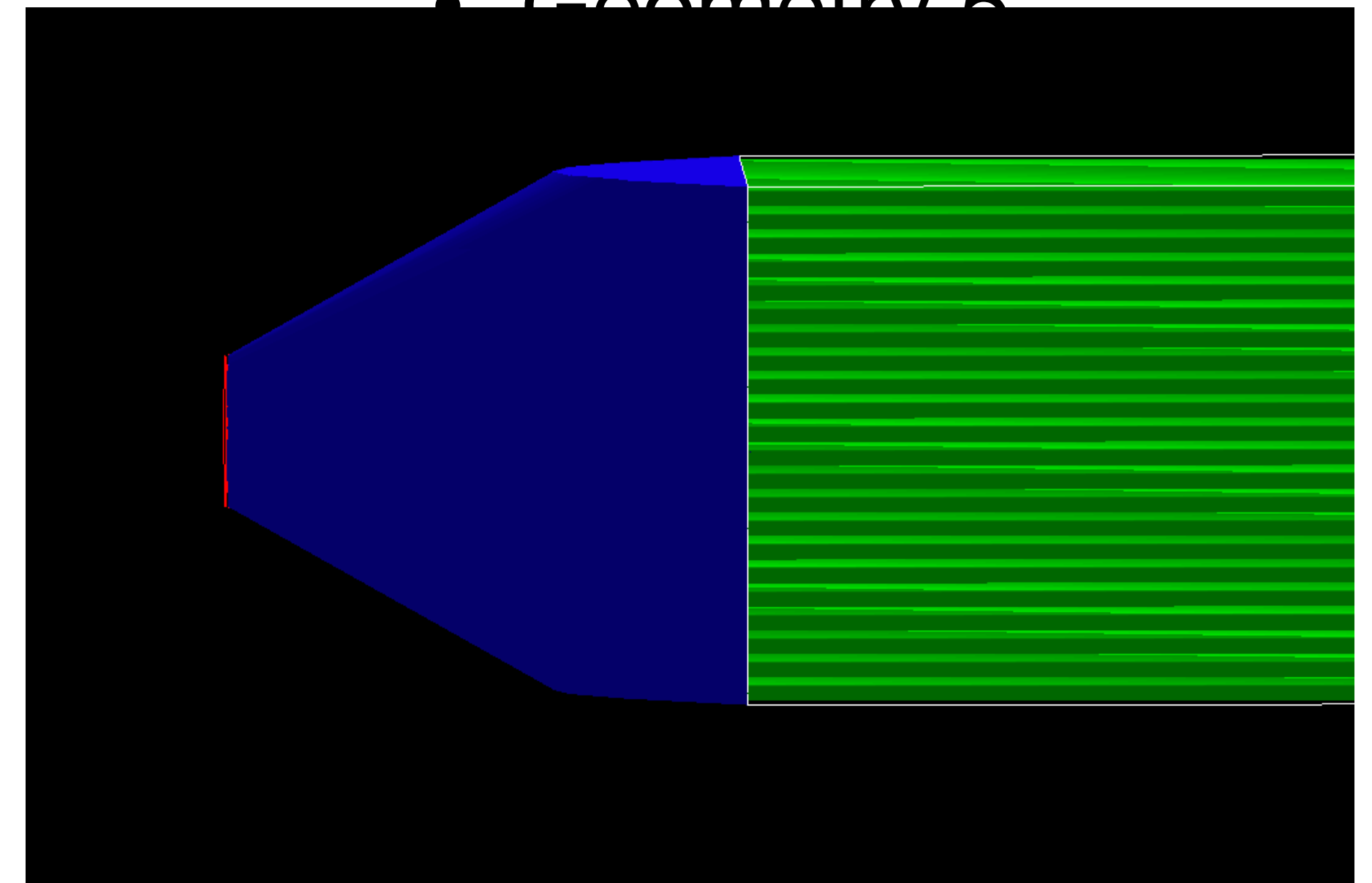

Fish Tail

```
G4VSolid* coneS = new G4Cons  
("aCone",0,PMT_radius,0, 0.5*sqrt(2)*(lguide_edge-2.0*airGap) ,  
0.5*PLEX_depth,0.0 * deg,360.0* deg);
```

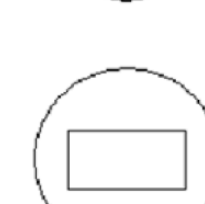
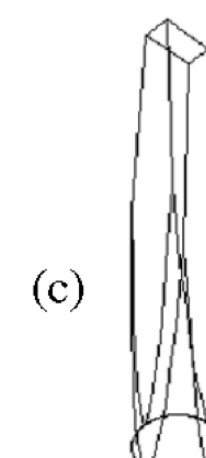
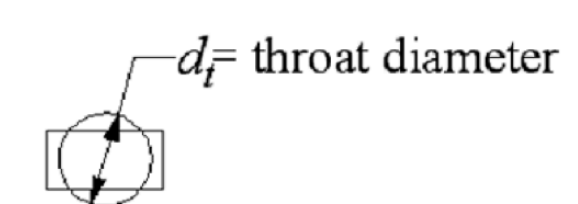
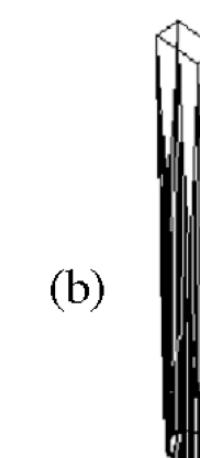
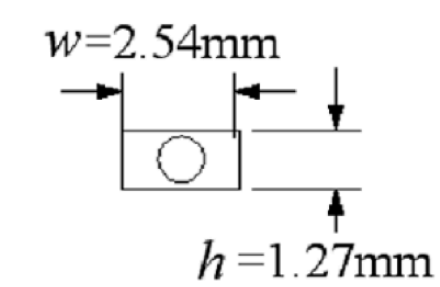
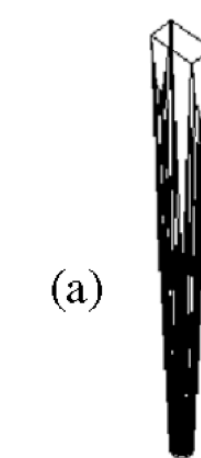
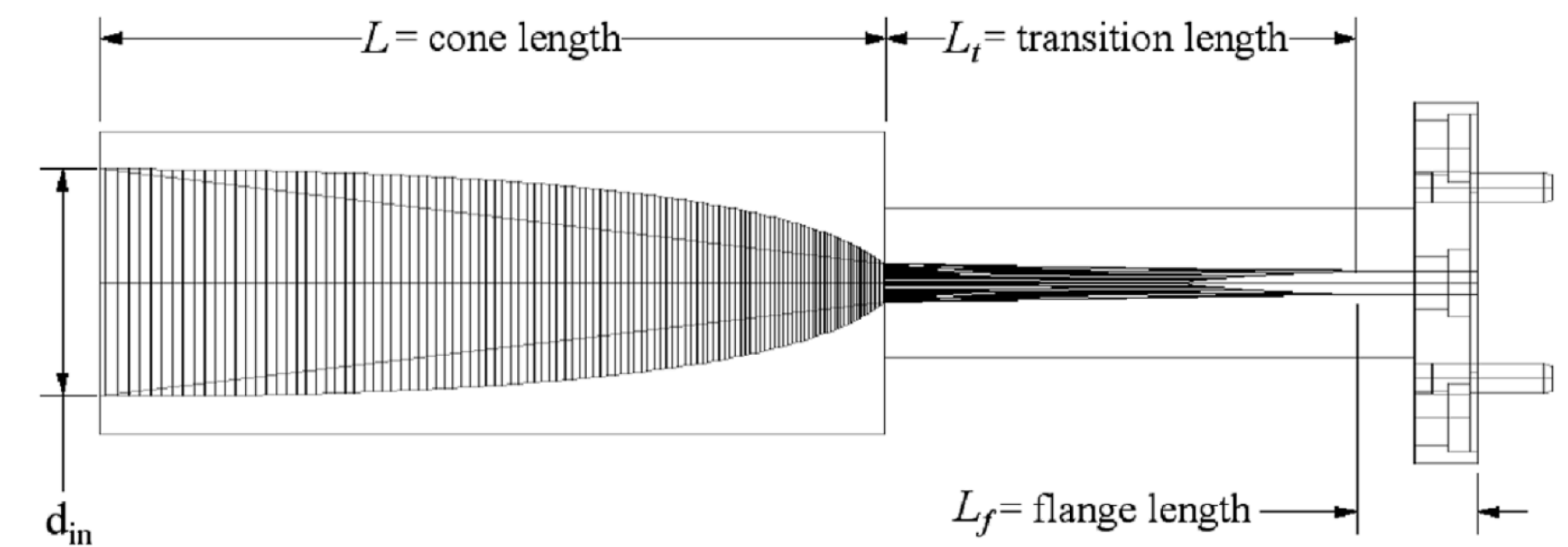
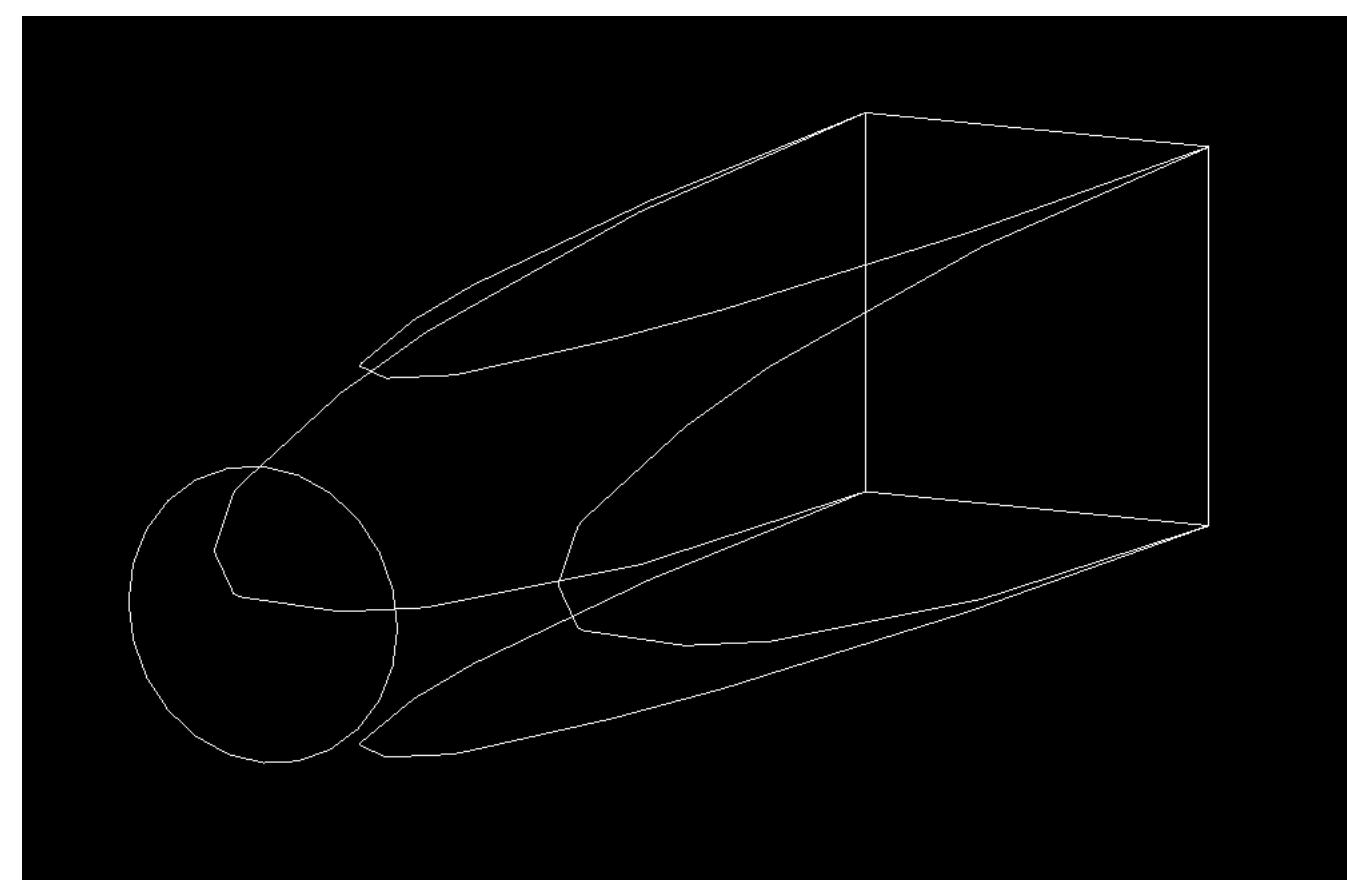
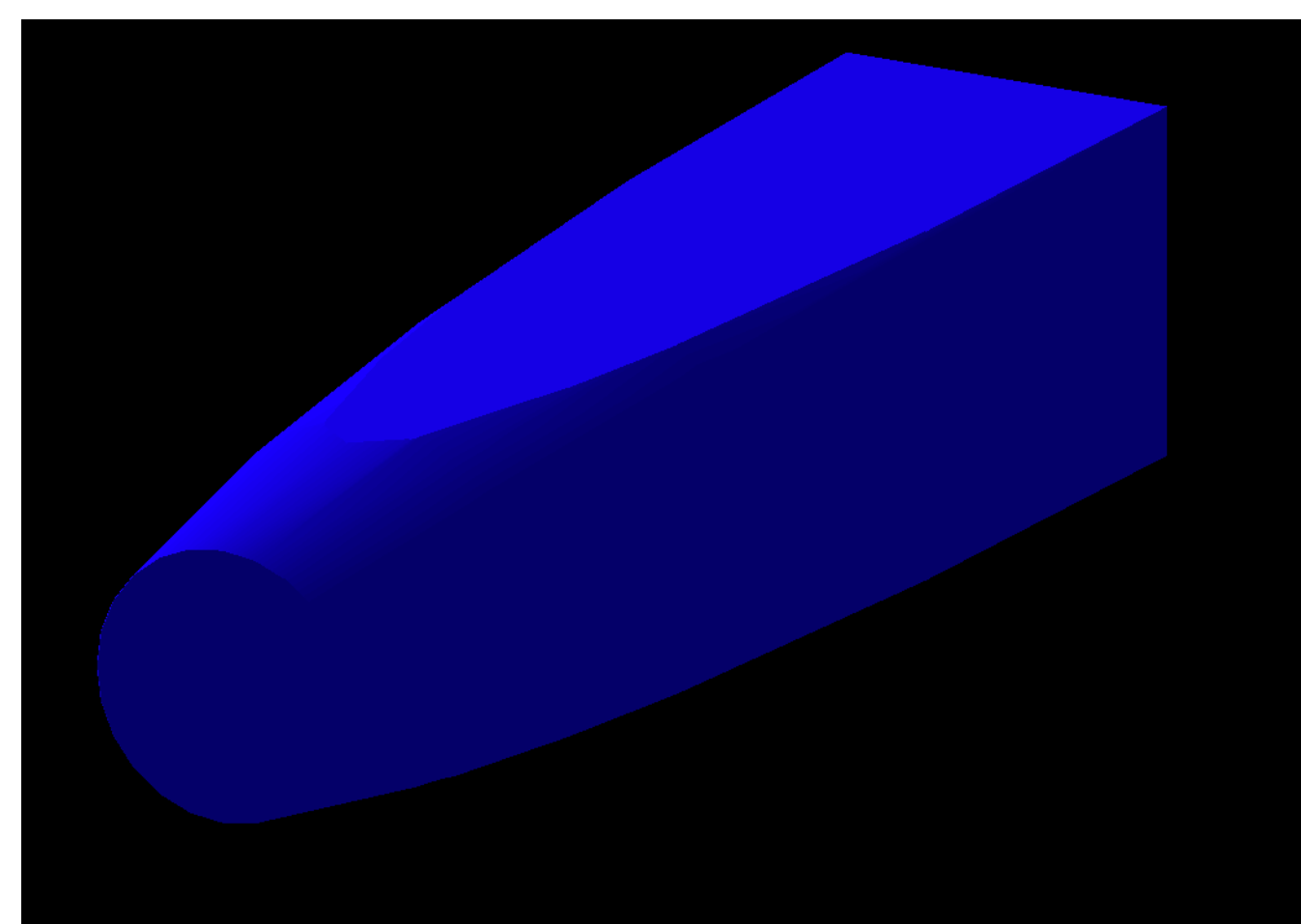
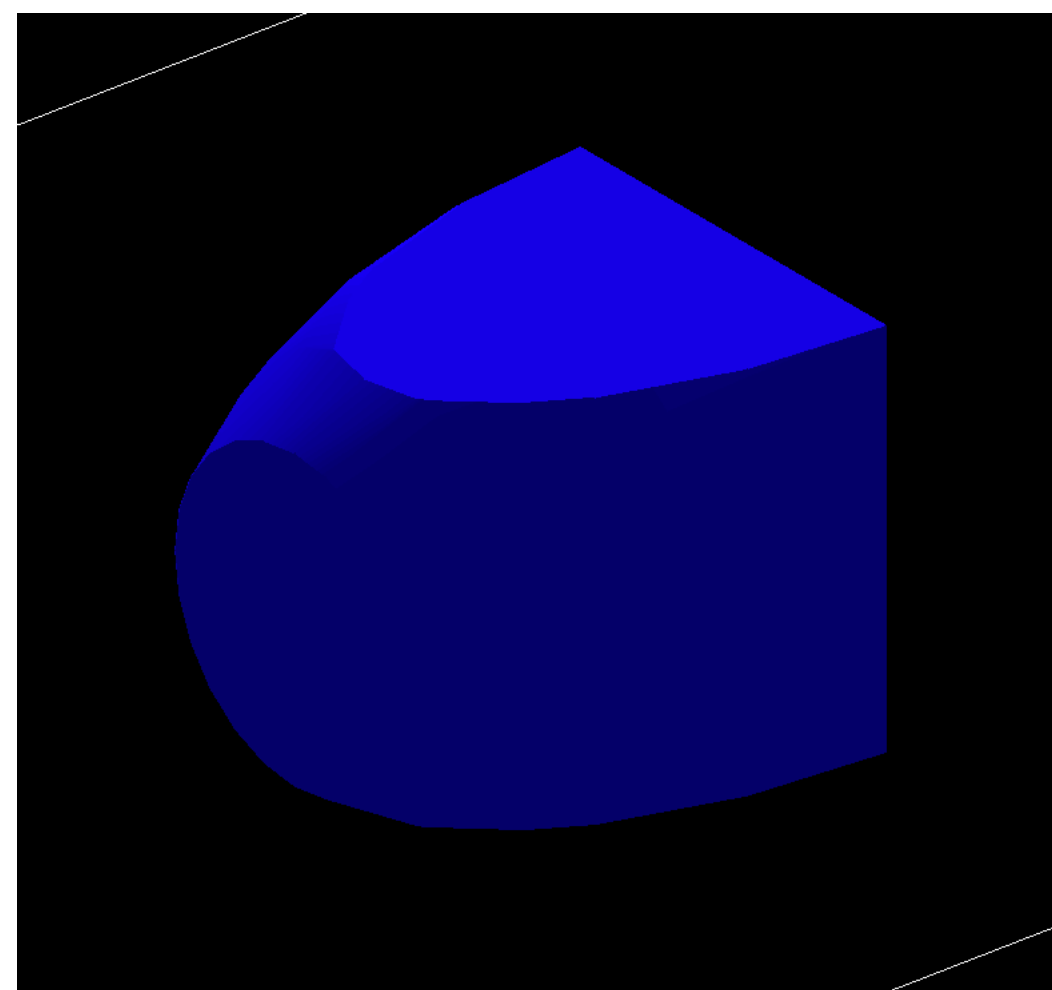
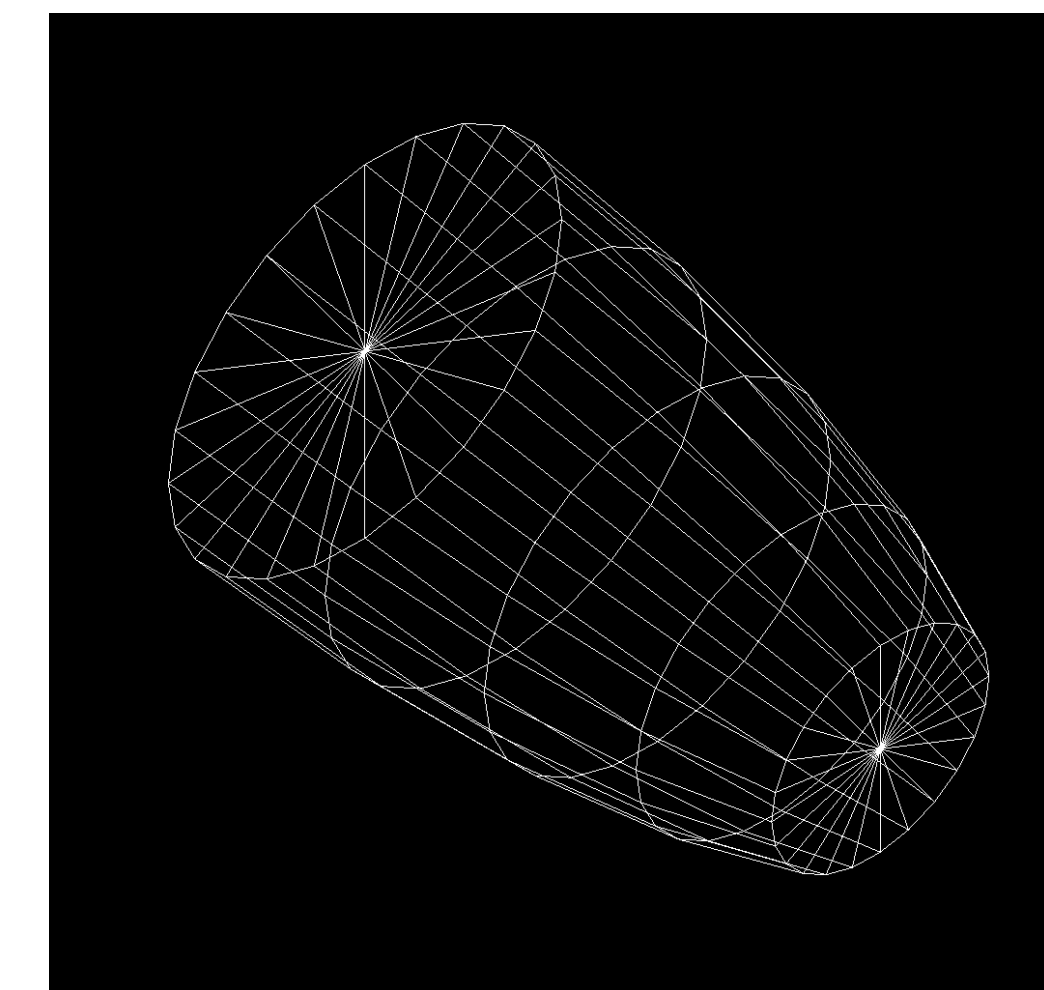
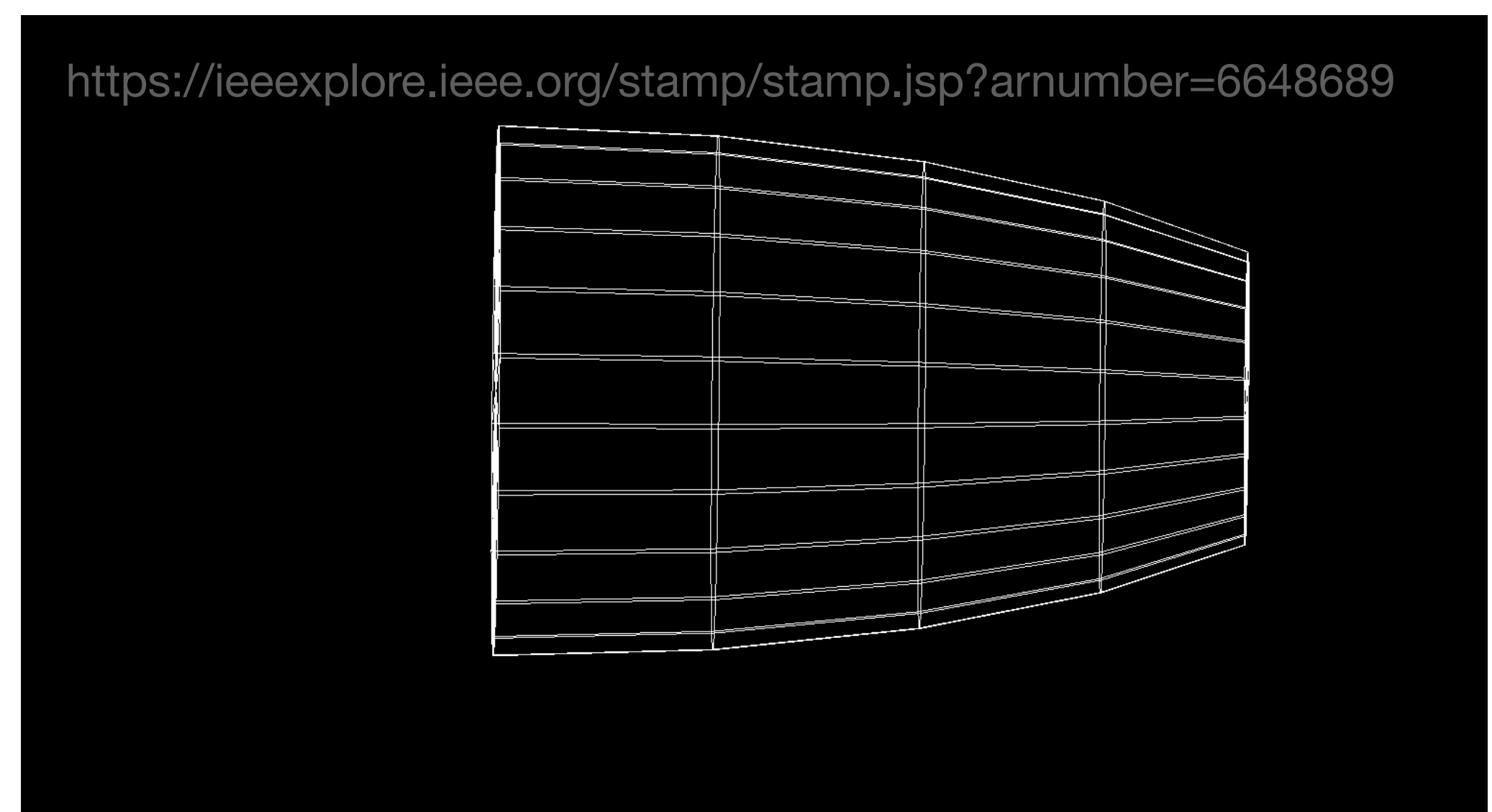
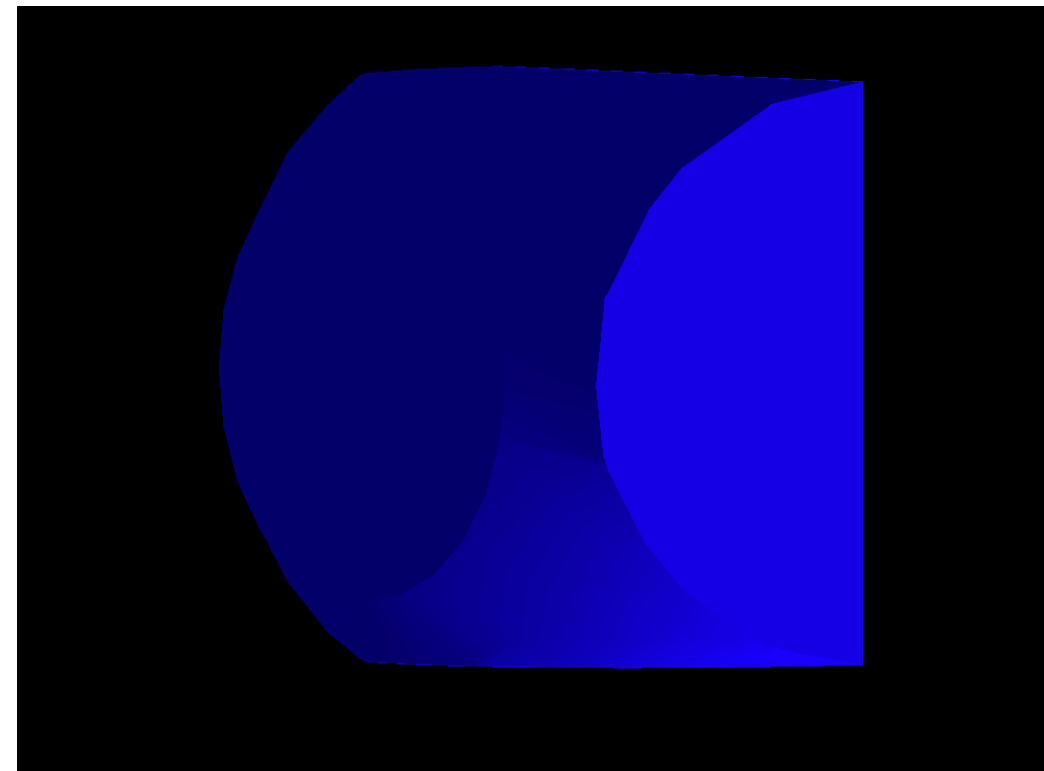
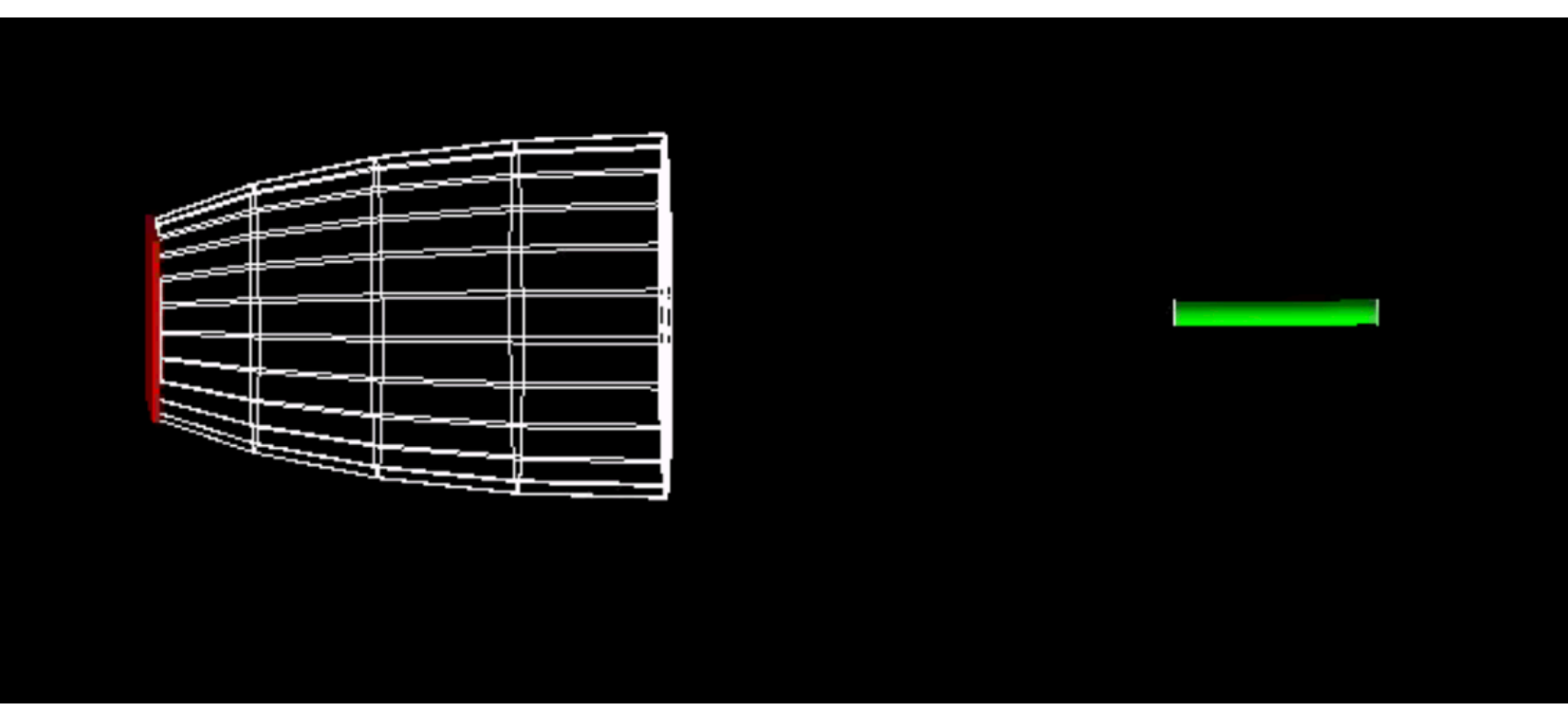

geometry 1.1

PMMA

Air

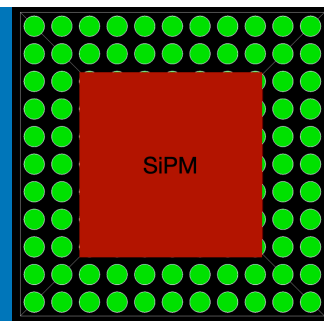

statistic 11.000 - muon 1 GeV

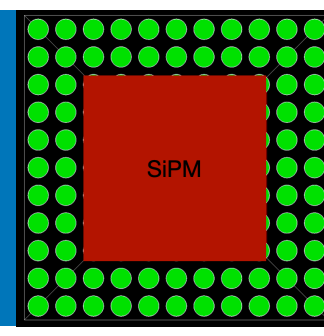

Efficiency - LG - PMMA - 2cm - base 18. mm

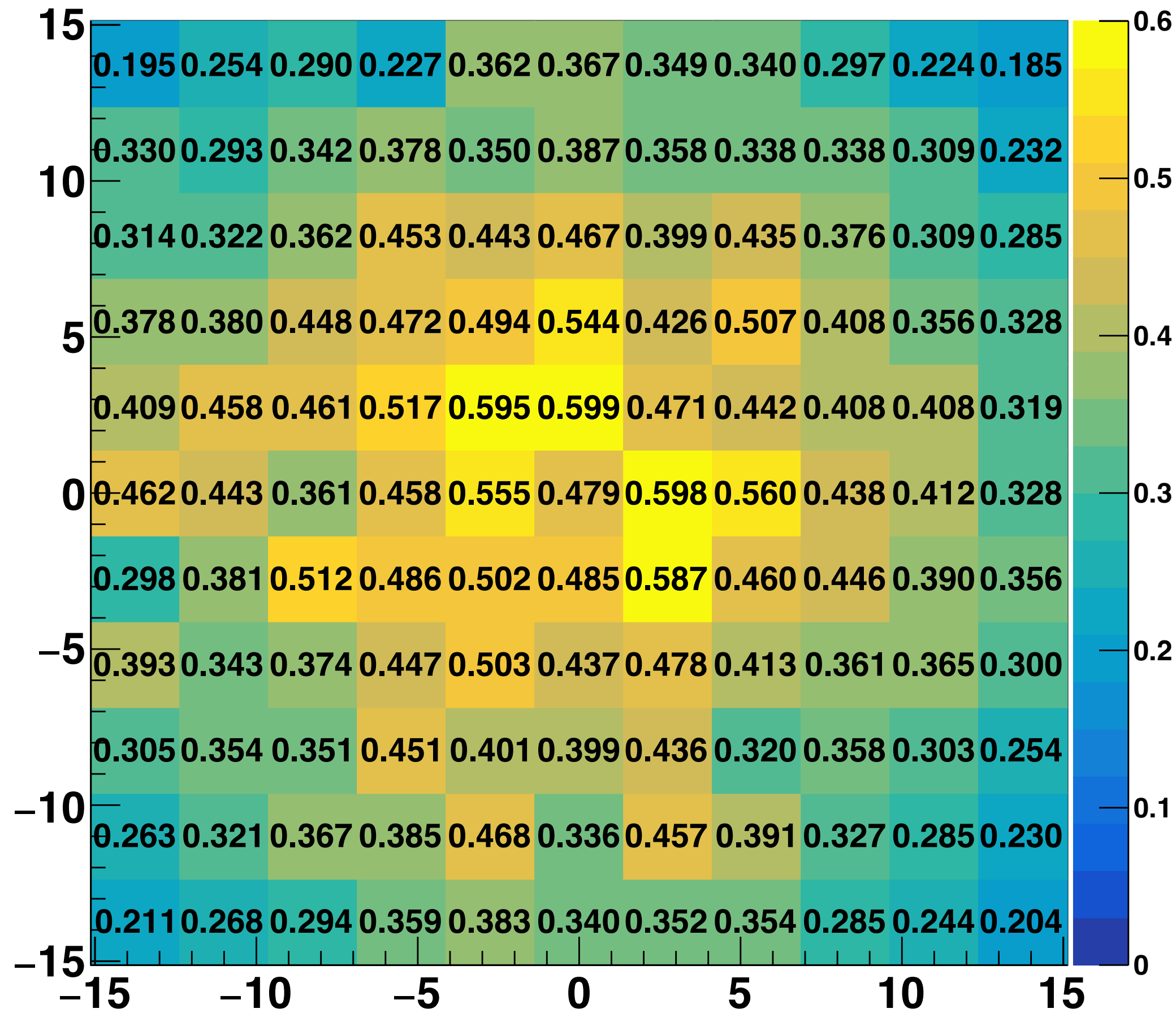

Factor non-uniformity - LG - PMMA - 2cm - base 18. mm

Standard deviation: 0.150

Mean value: 0.638

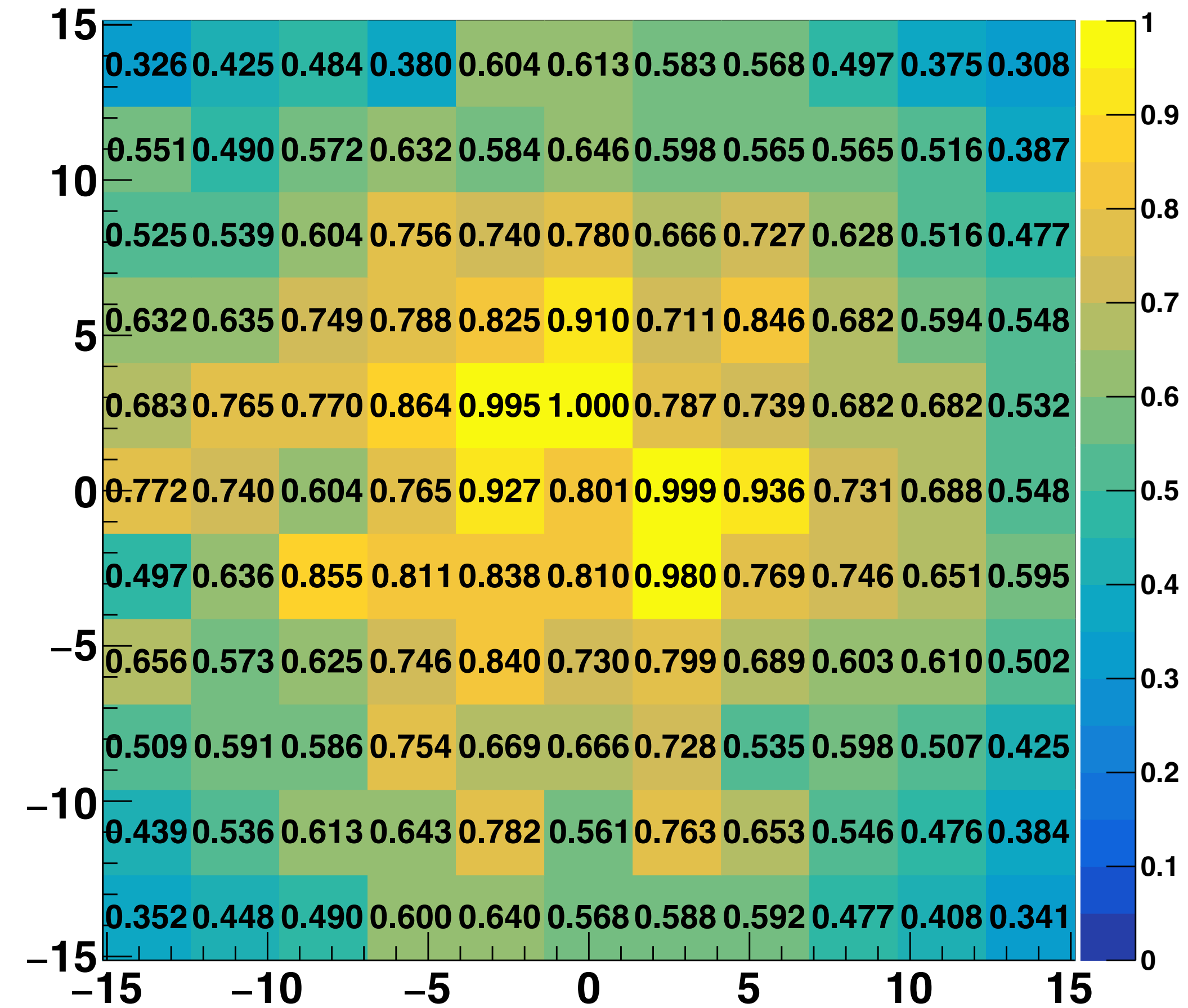

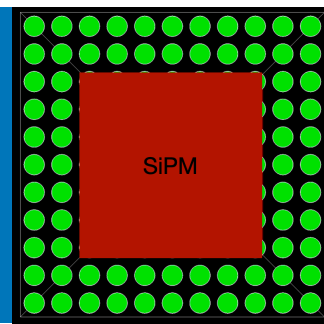

Efficiency - LG - PMMA - 3cm - base 18. mm

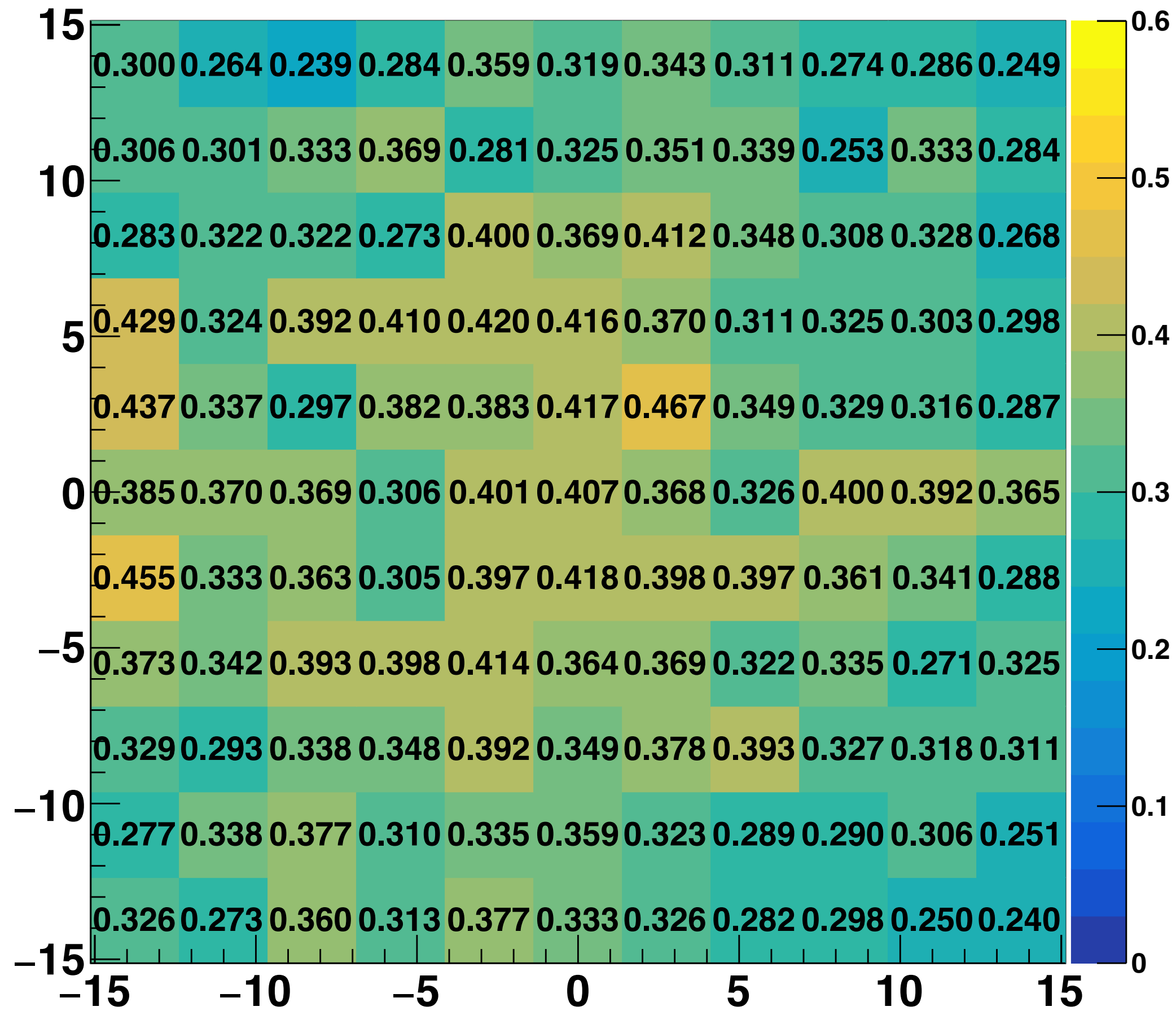

Factor non-uniformity - LG - PMMA - 3cm - base 18. mm

Standard deviation: 0.105

Mean value: 0.726

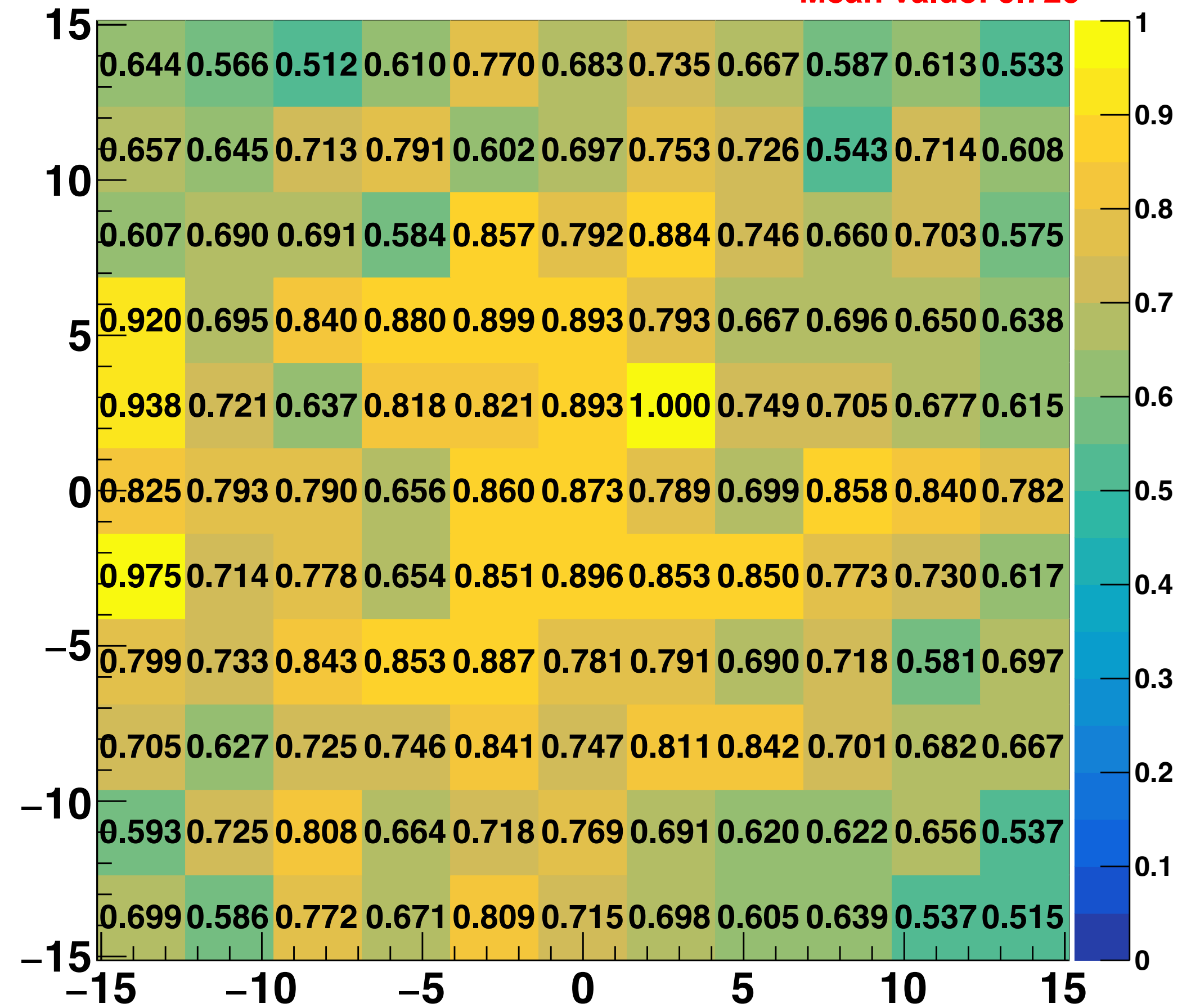

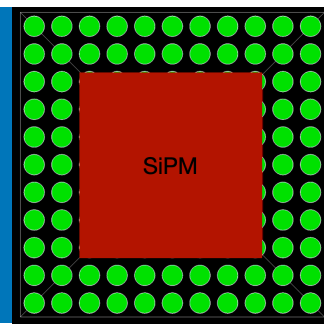

Efficiency - LG - PMMA - 4cm - base 18. mm

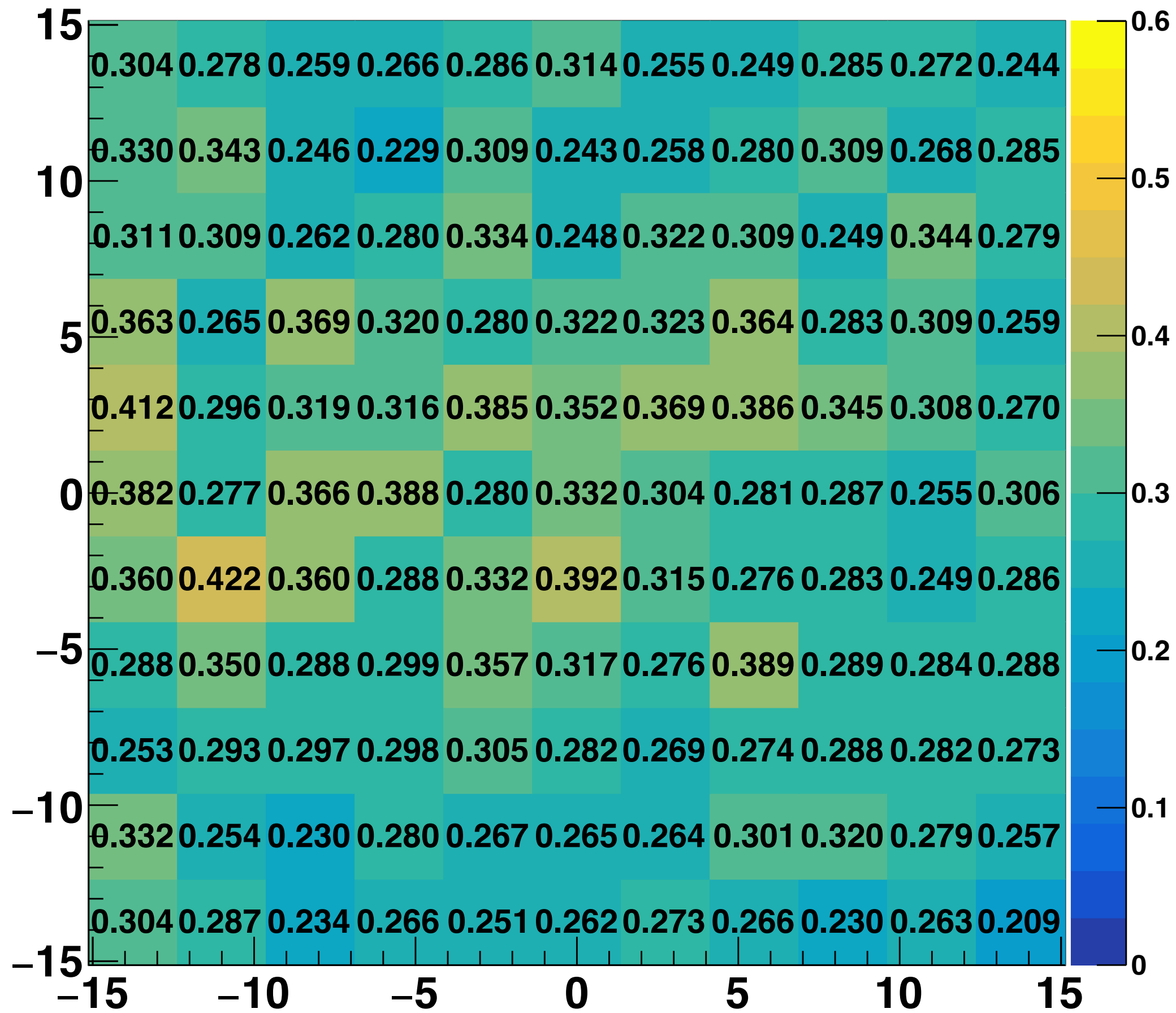

Factor non-uniformity - LG - PMMA - 4cm - base 18. mm

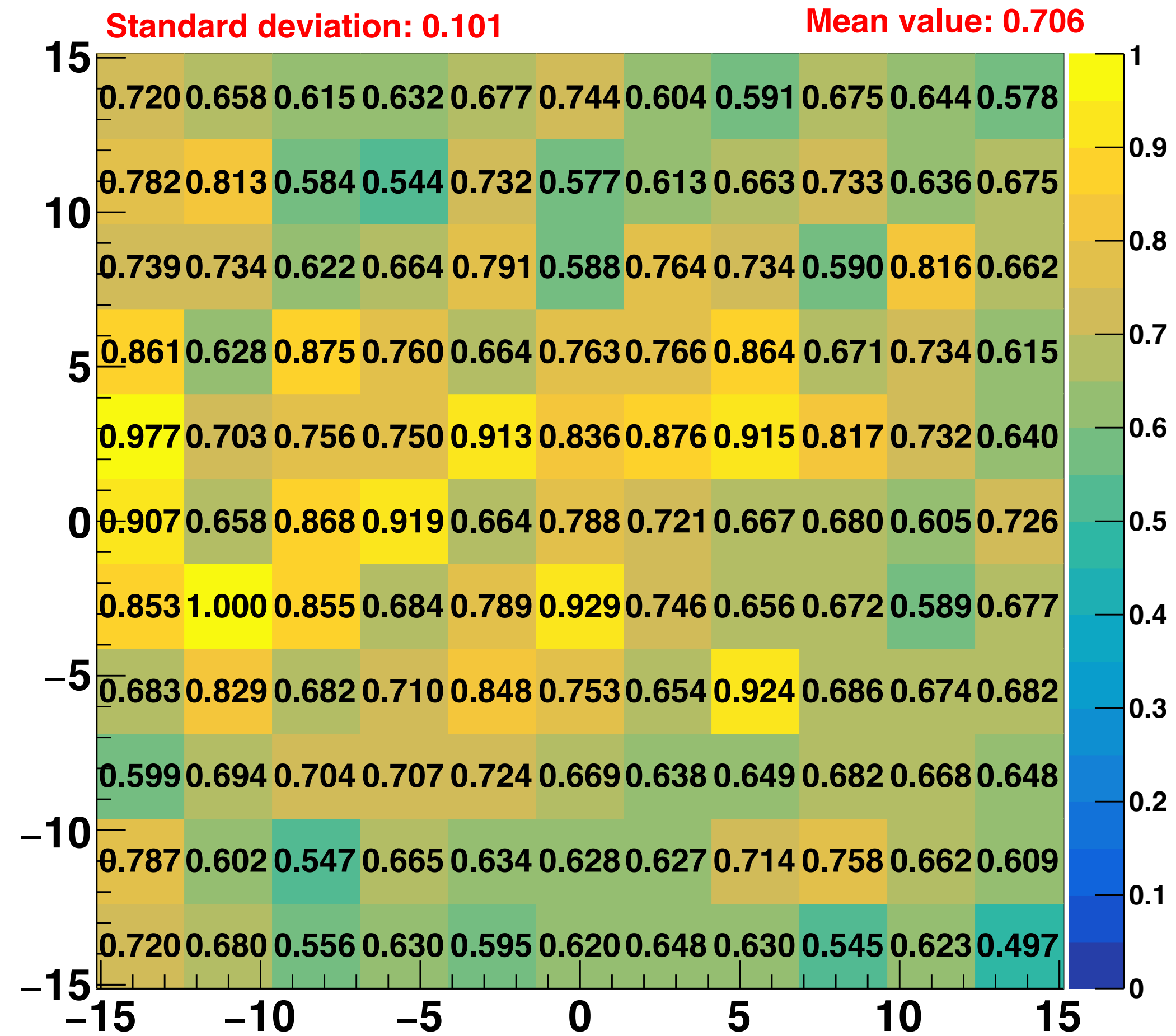

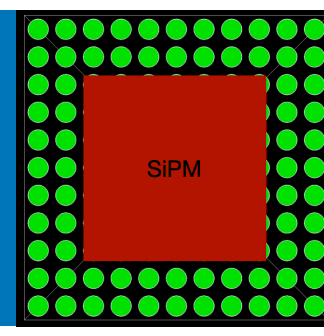

Efficiency - LG - PMMA - 5cm - base 18. mm

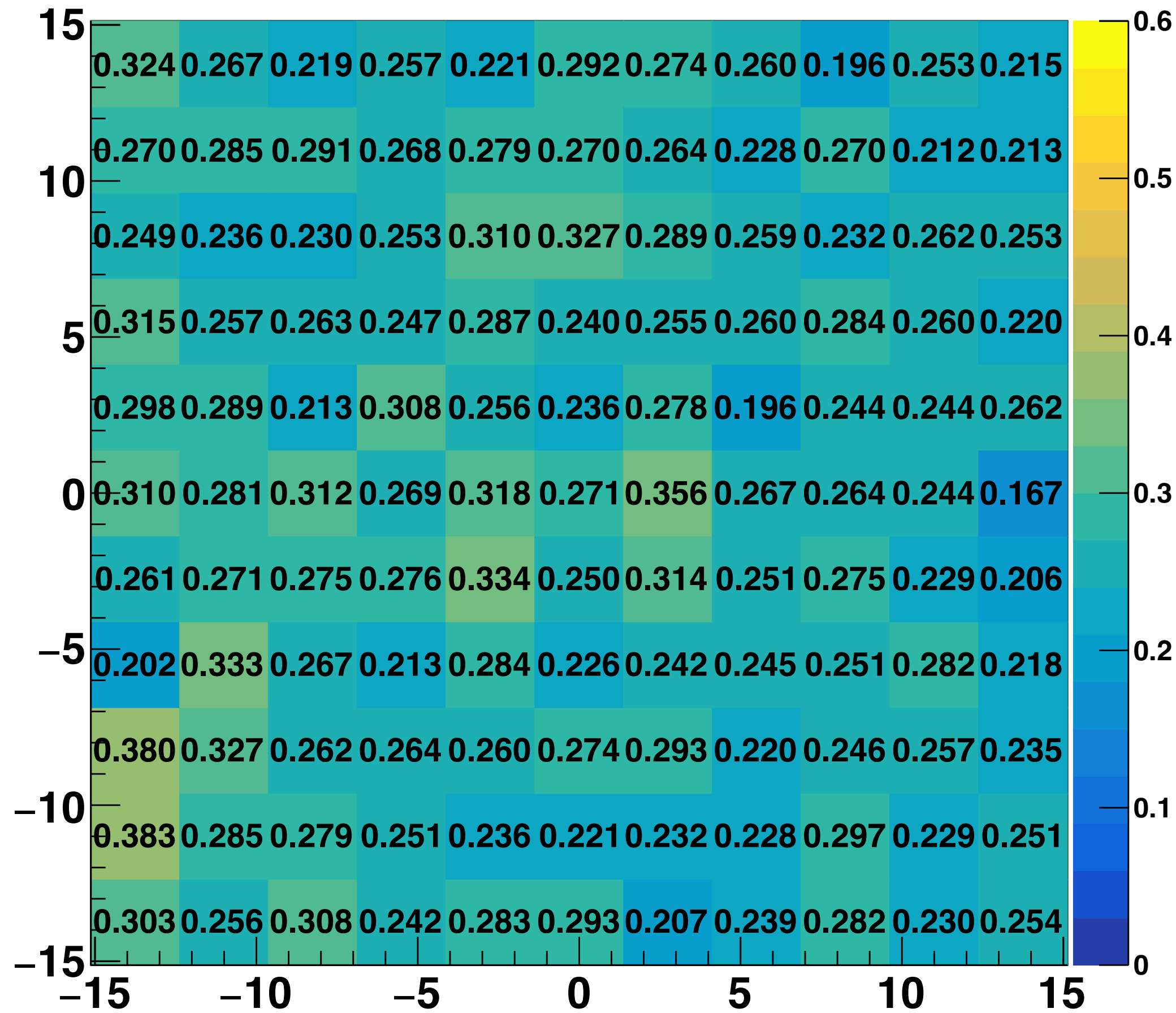

Factor non-uniformity - LG - PMMA - 5cm - base 18. mm

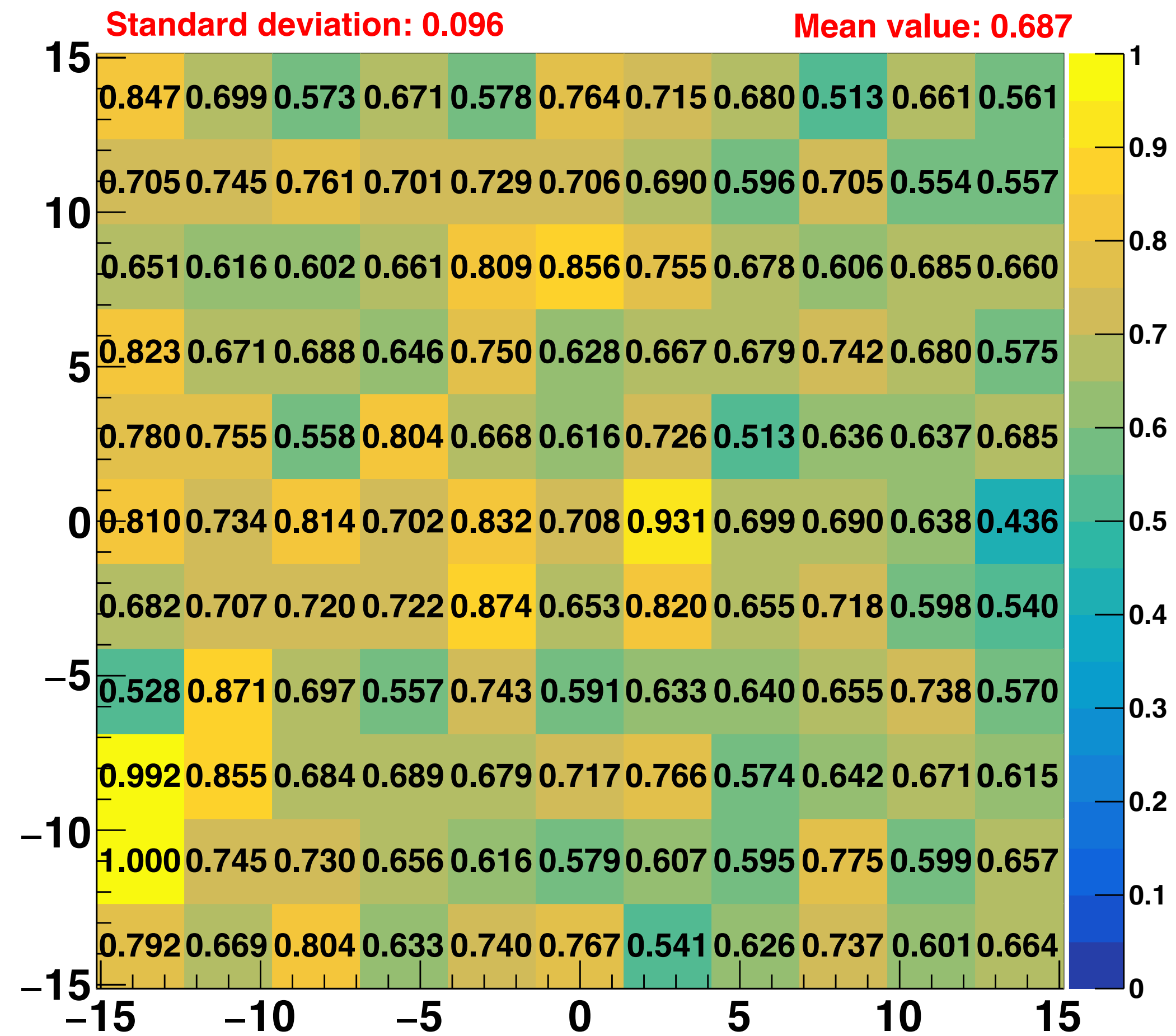

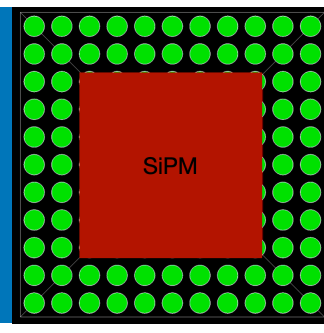

Efficiency - LG - PMMA - 6cm - base 18. mm

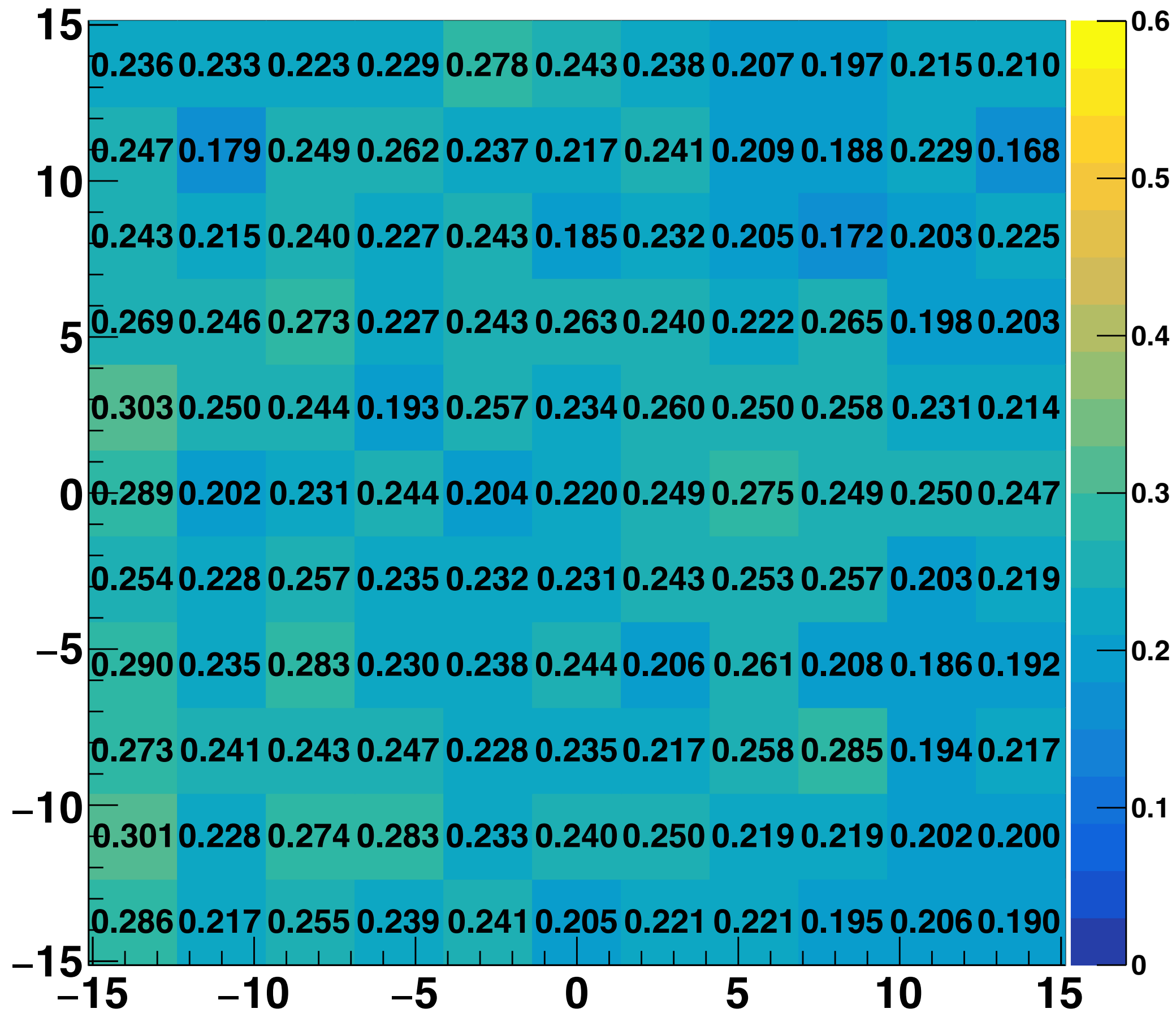

Factor non-uniformity - LG - PMMA - 6cm - base 18. mm

Standard deviation: 0.091

Mean value: 0.771

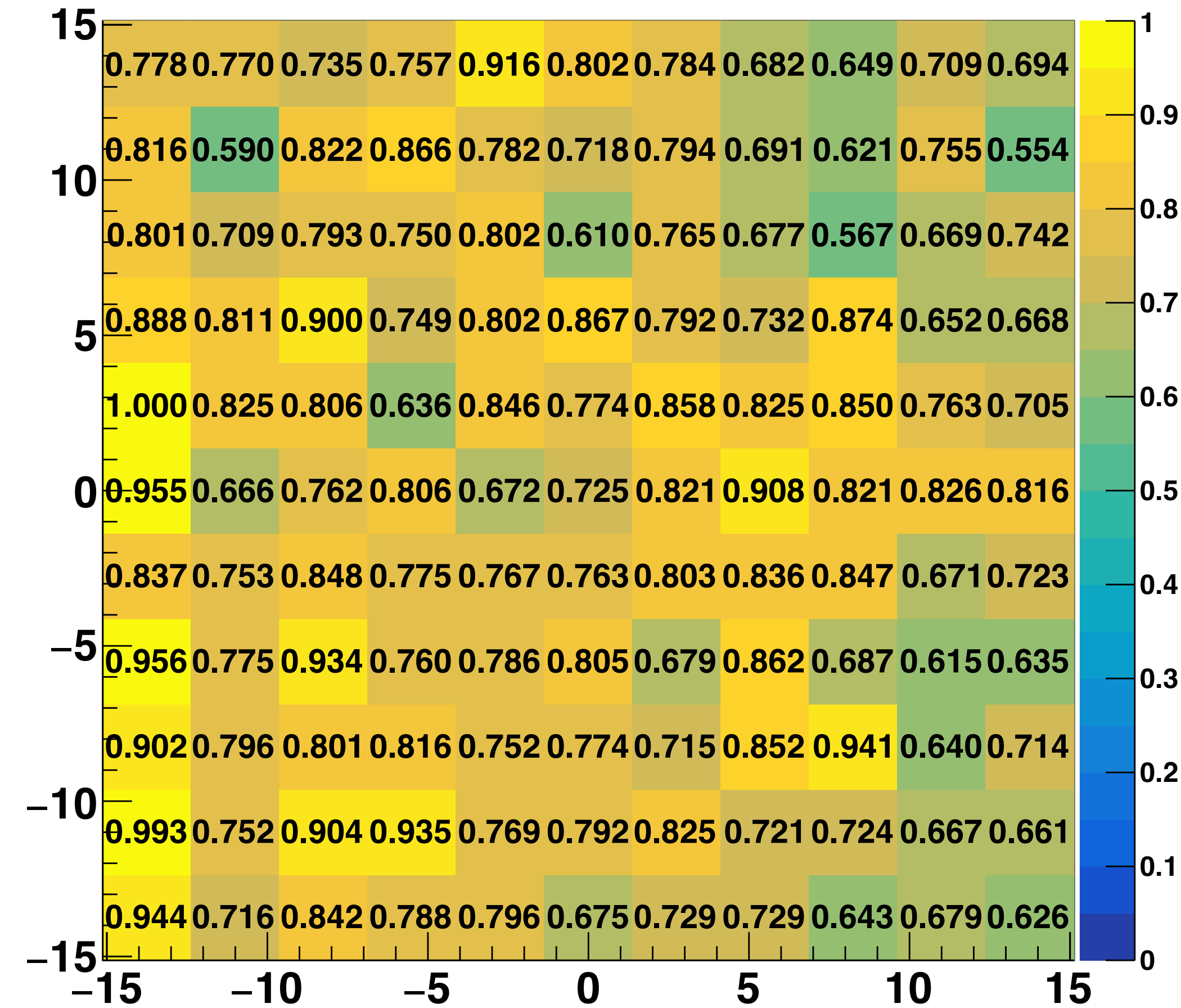

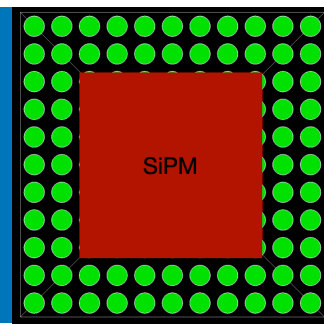

Efficiency - LG - Air - 2cm - base 18. mm

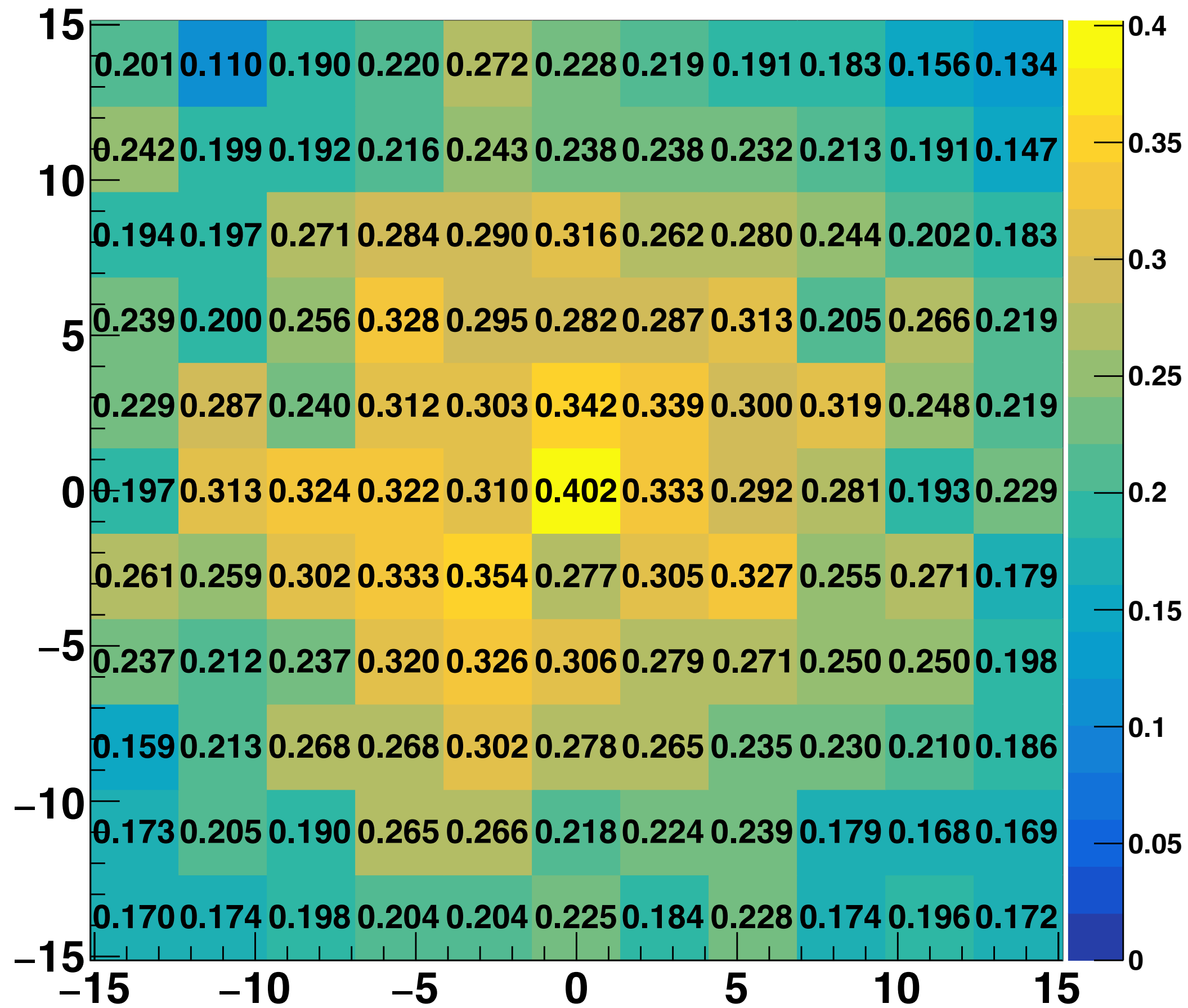

Factor non-uniformity - LG - AIR - 2cm - base 18. mm

Standard deviation: 0.135

Mean value: 0.606

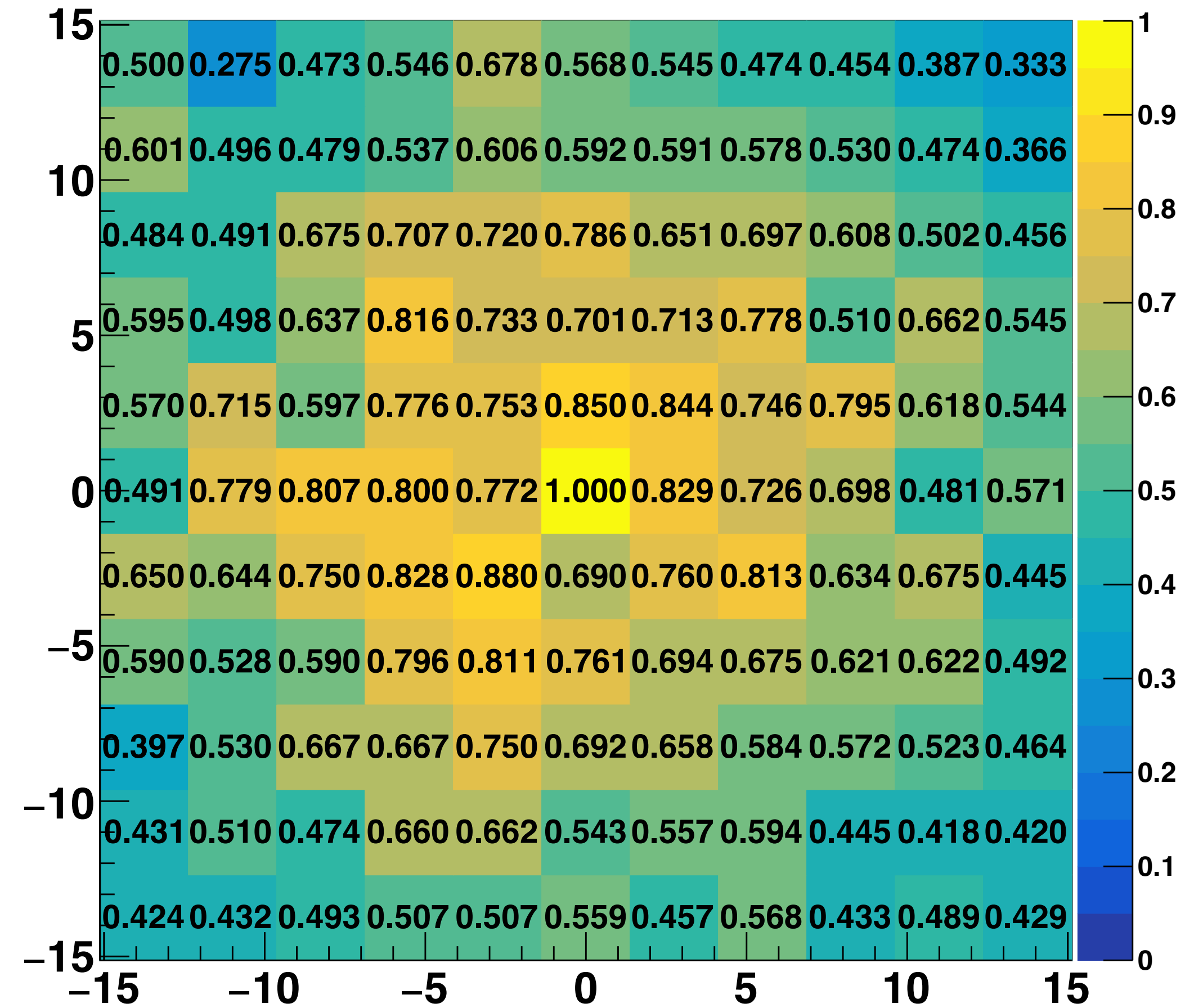

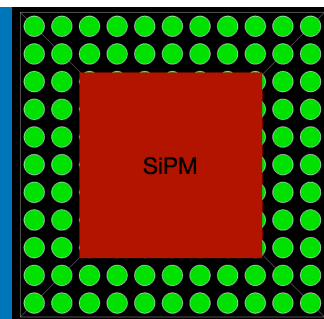

Efficiency - LG - Air - 3cm - base 18. mm

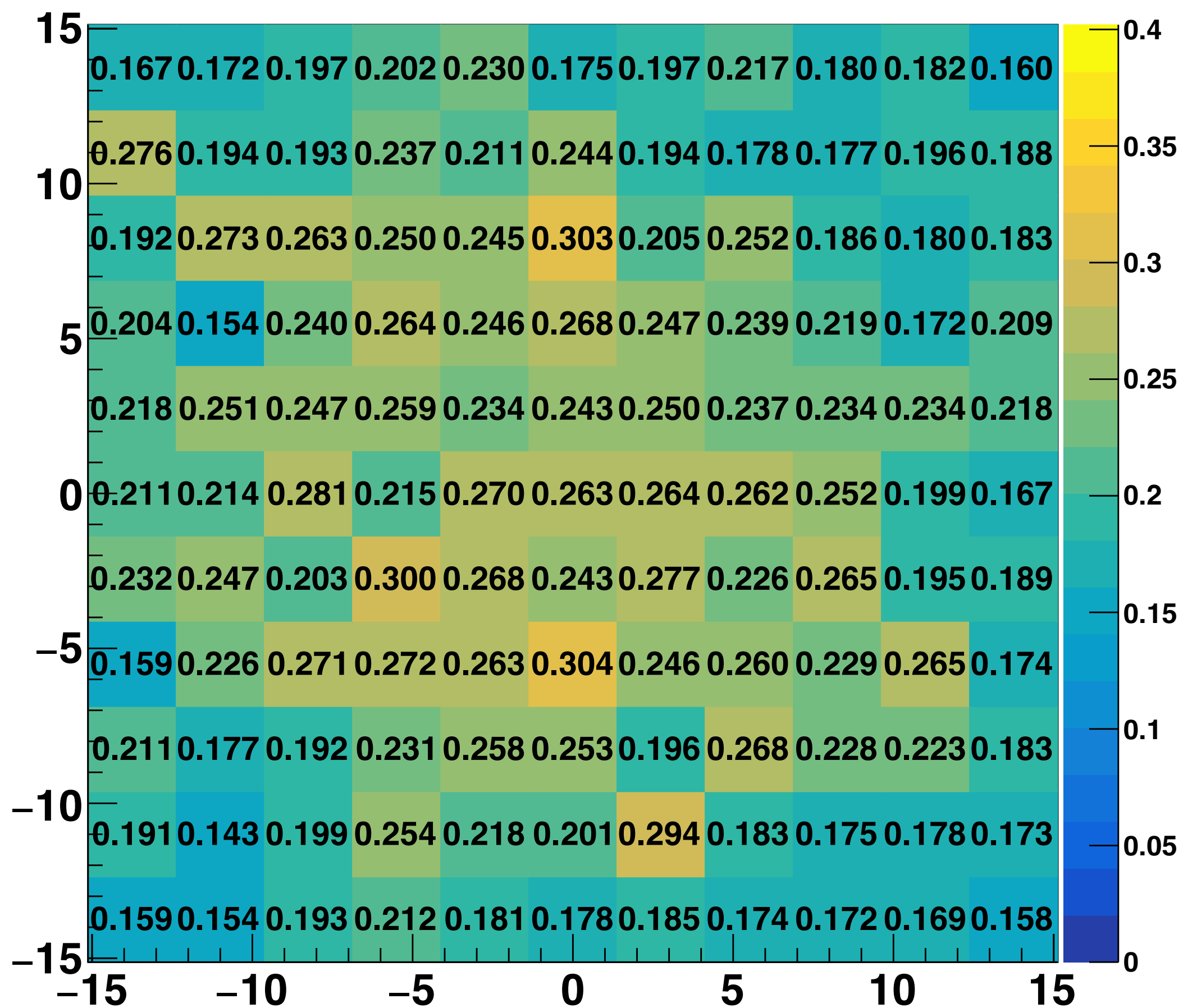

Factor non-uniformity - LG - AIR - 3cm - base 18. mm

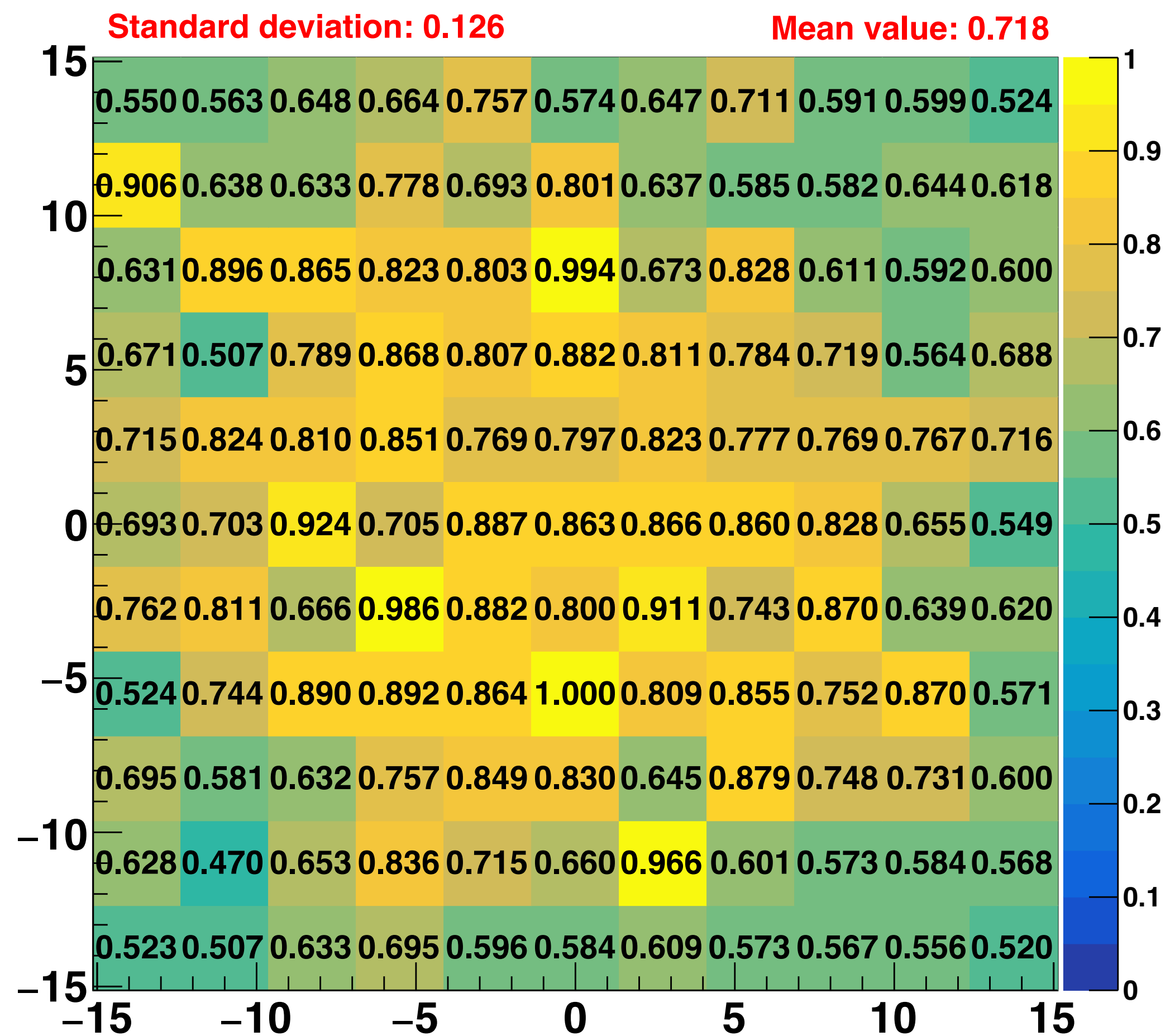

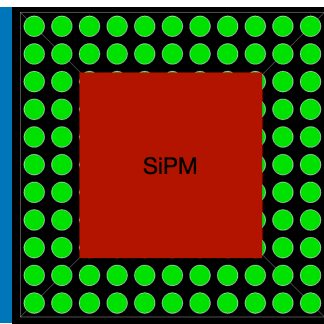

Efficiency - LG - Air - 4cm - base 18. mm

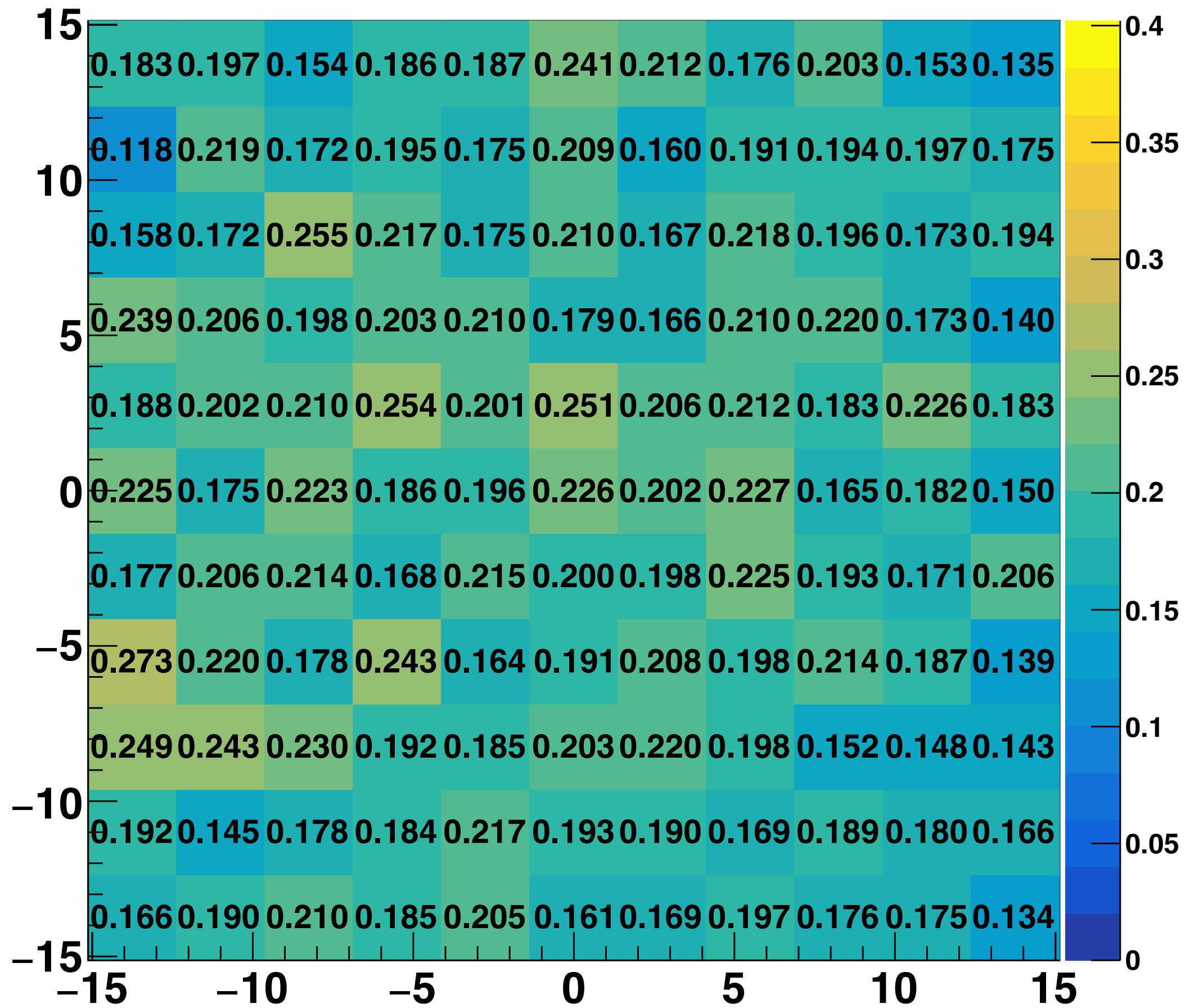

Factor non-uniformity - LG - AIR - 4cm - base 18. mm

Standard deviation: 0.103

Mean value: 0.705

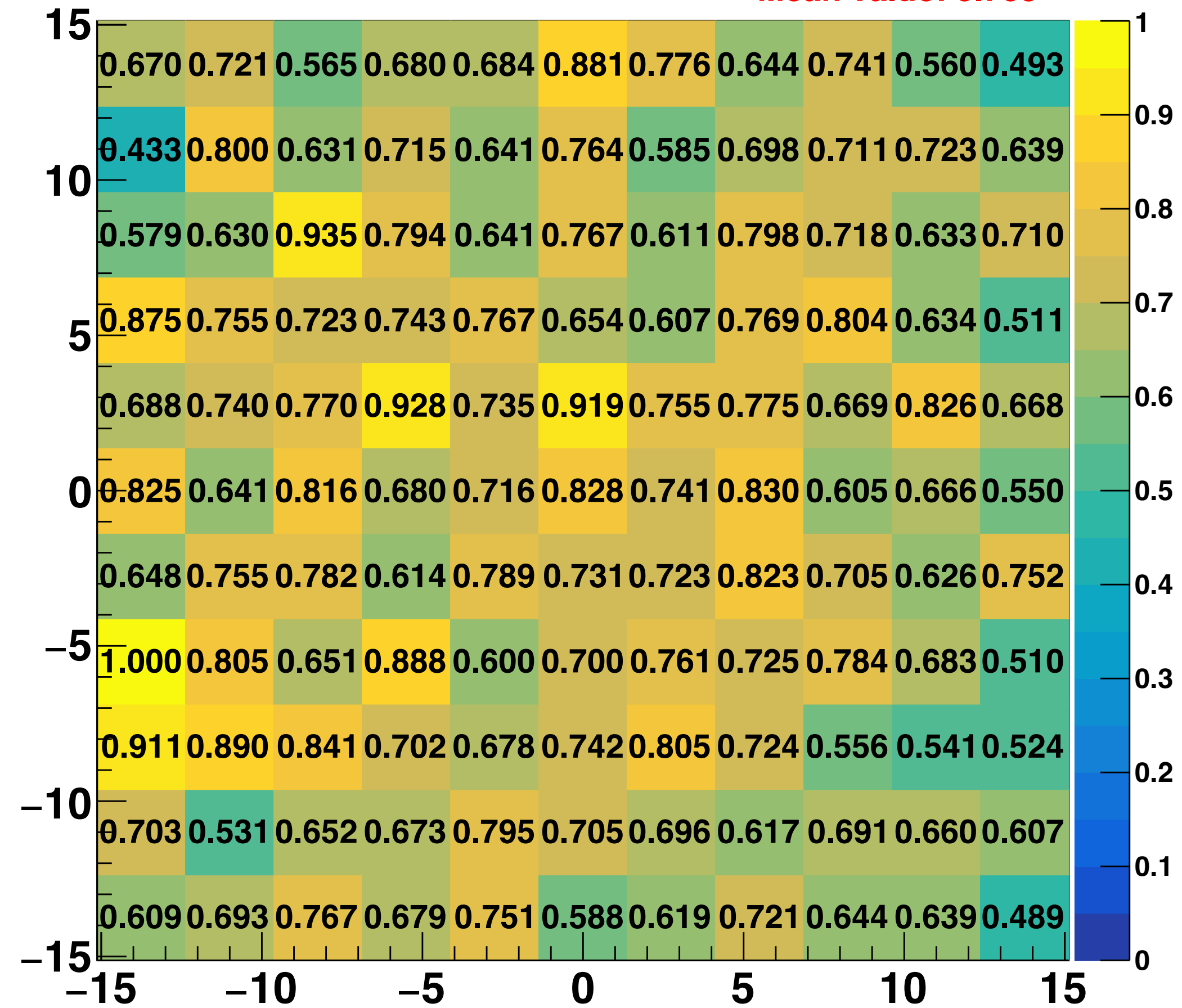

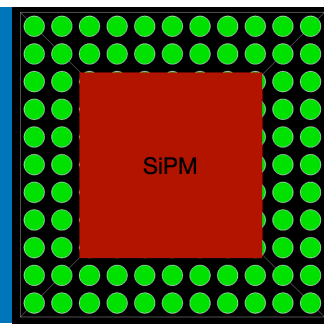

Efficiency - LG - Air - 5cm - base 18. mm

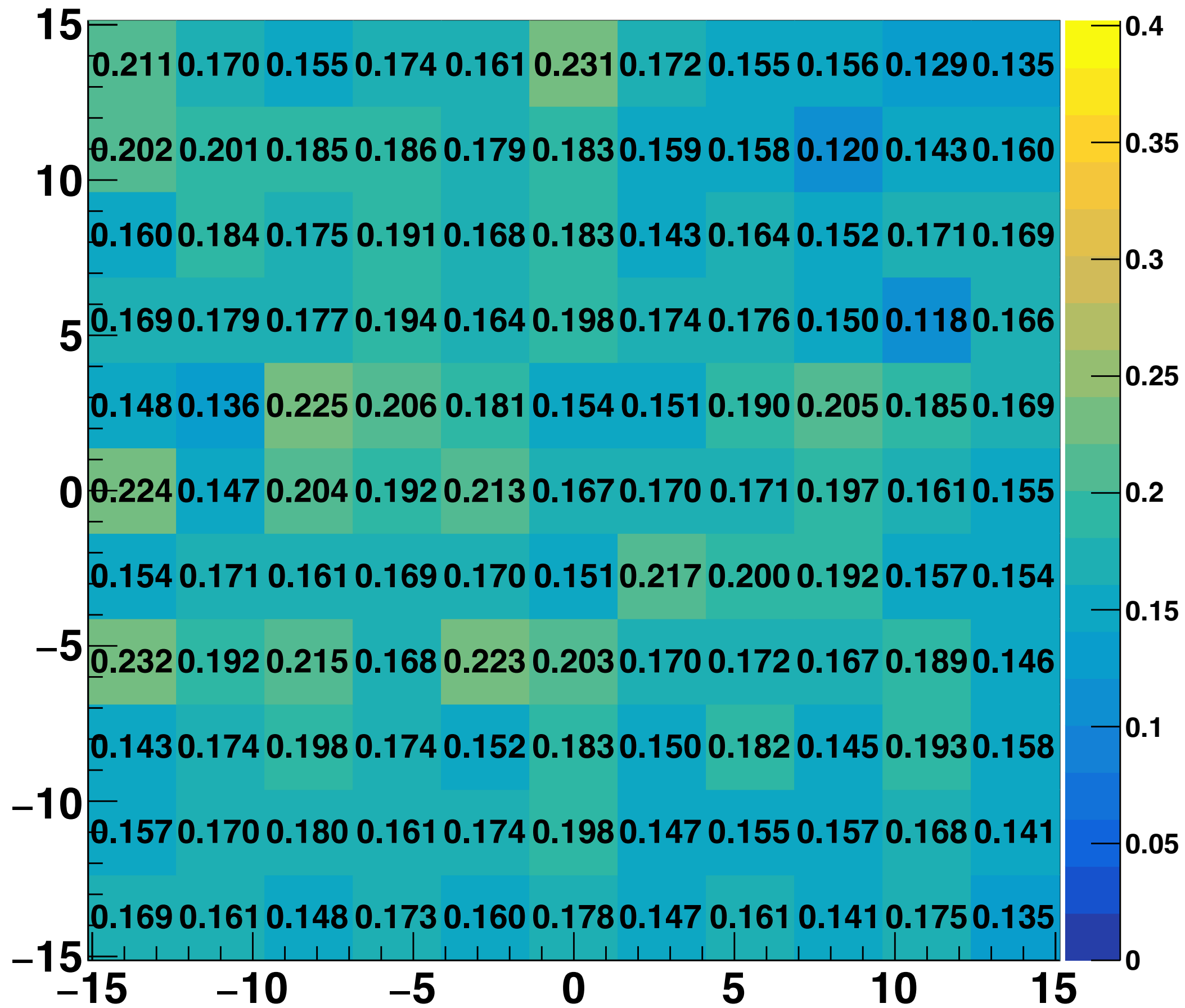

Factor non-uniformity - LG - AIR - 5cm - base 18. mm

Standard deviation: 0.099

Mean value: 0.739

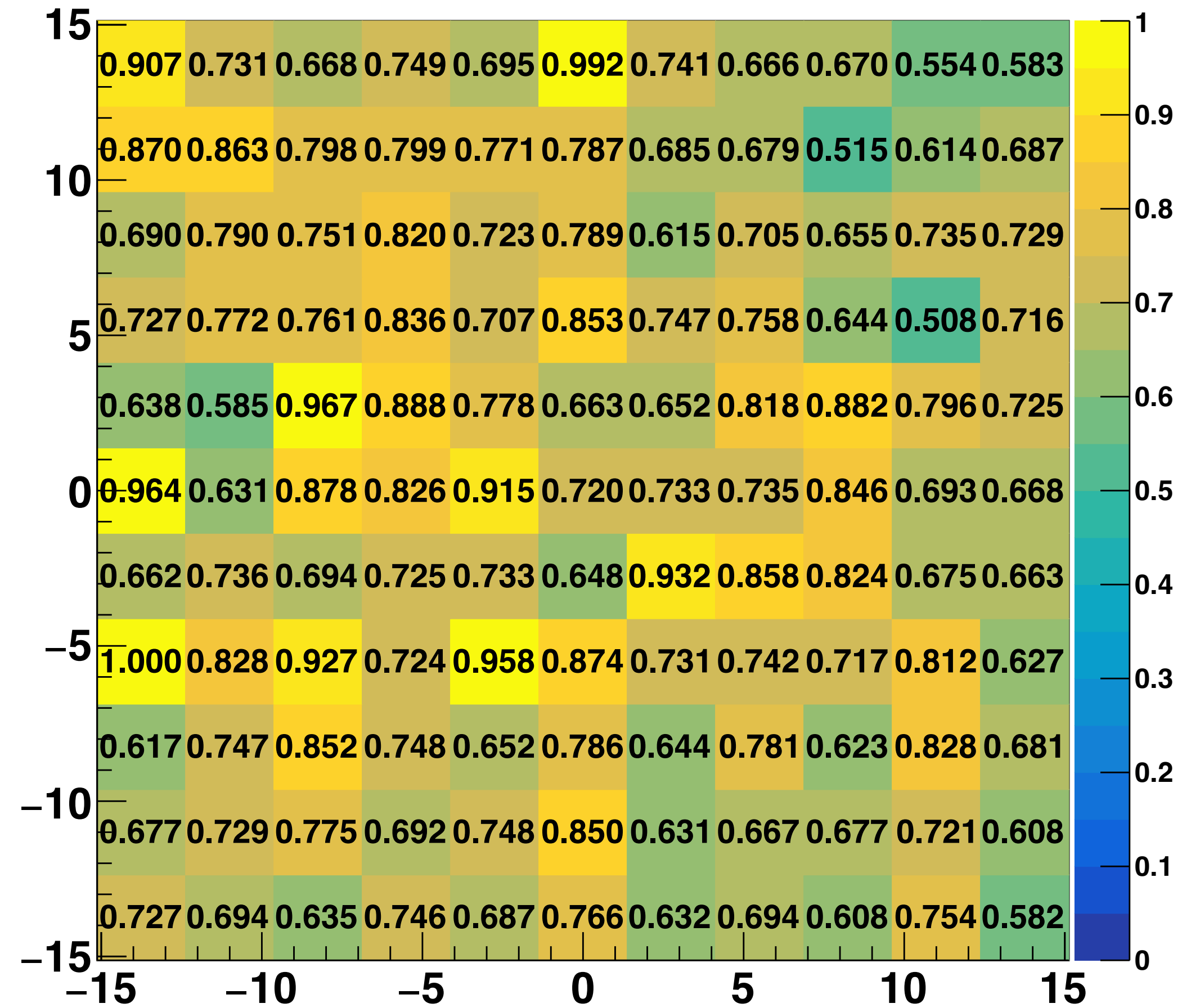

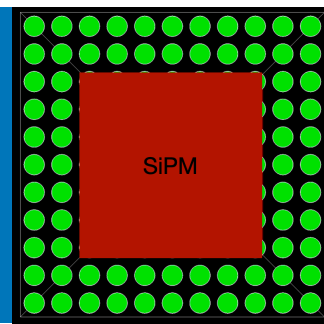

Efficiency - LG - Air - 6cm - base 18. mm

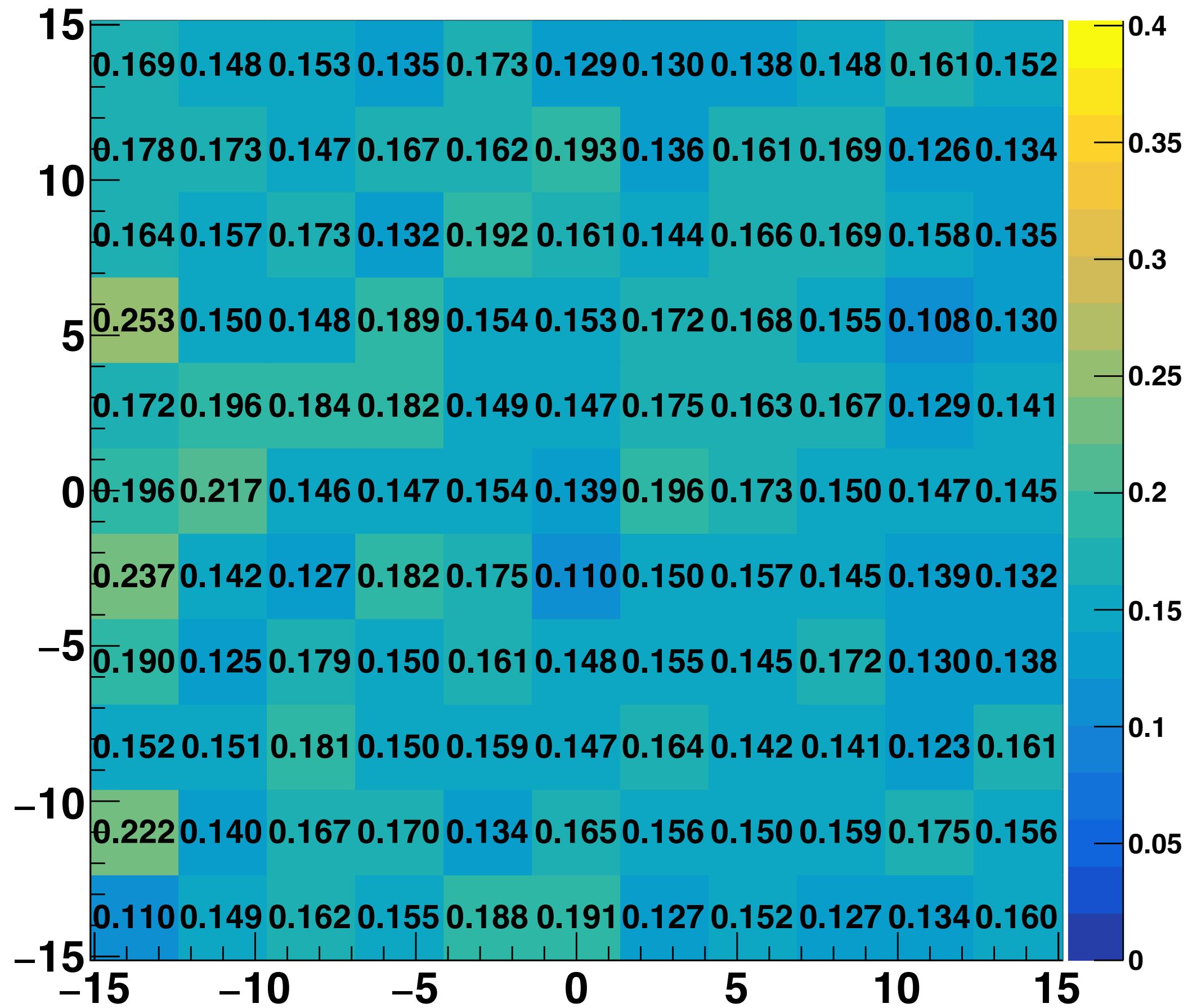

Factor non-uniformity - LG - AIR - 6cm - base 18. mm

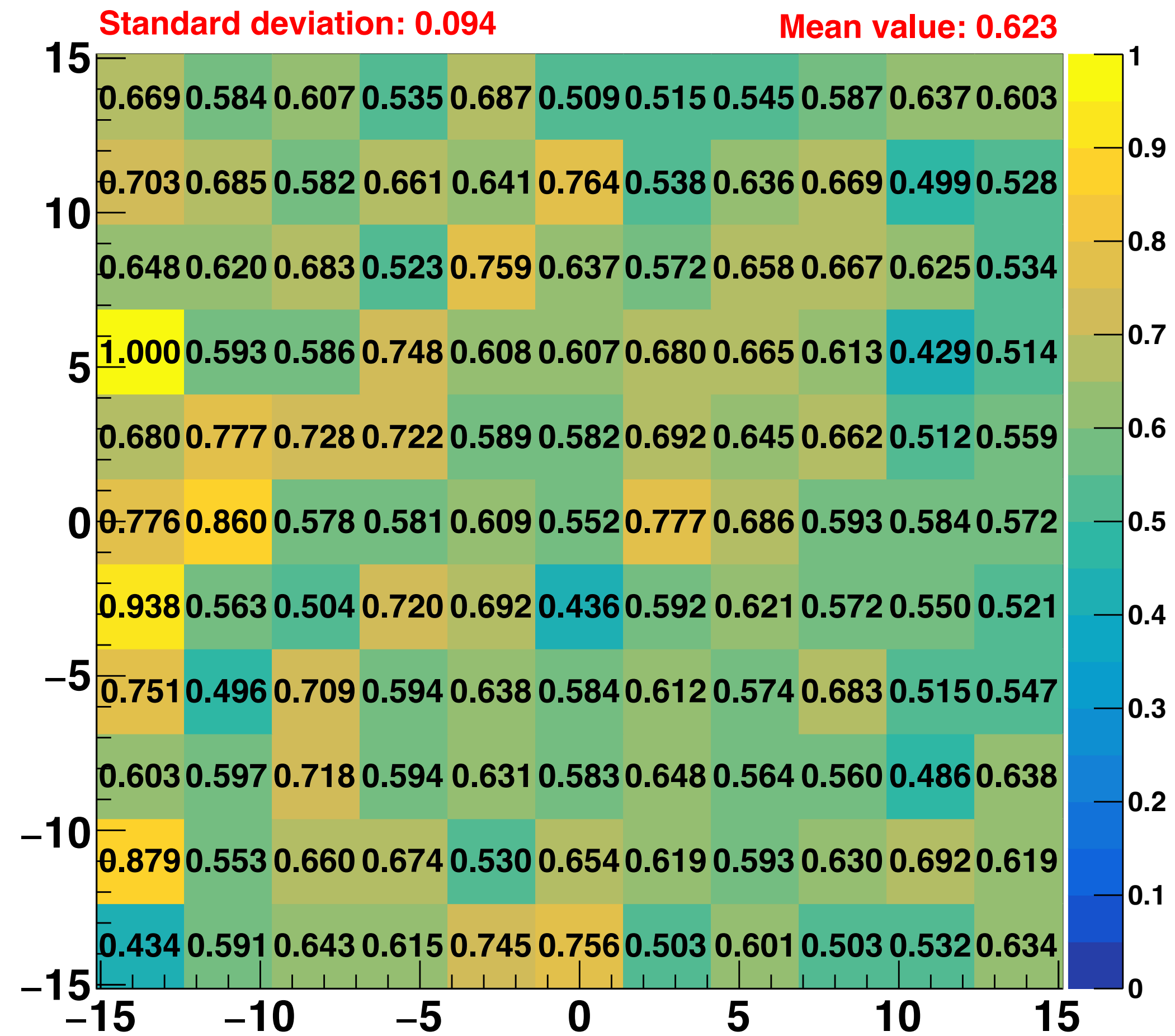

Geometry 1.1 -- PMMA - 18mm GI

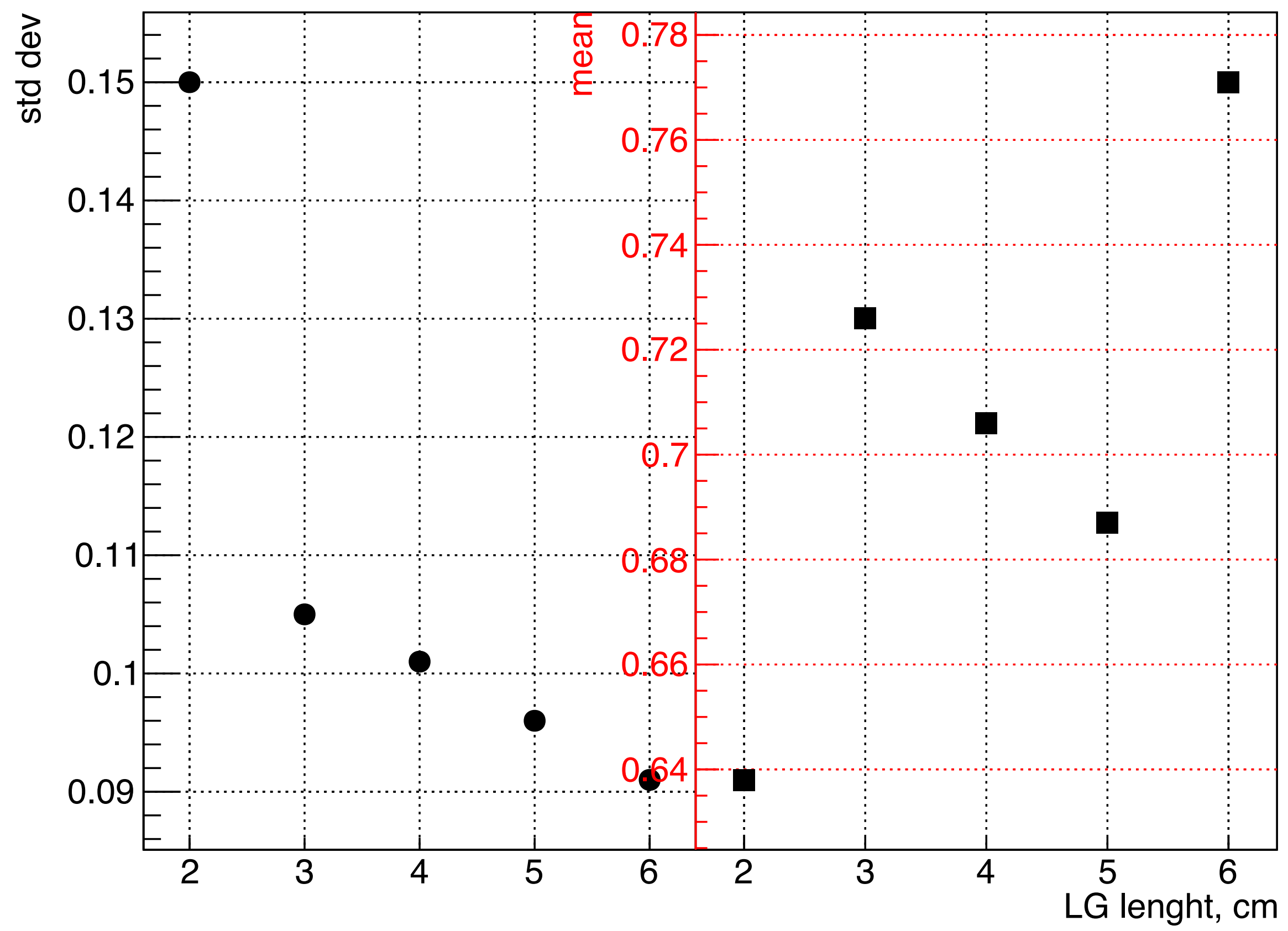

Geometry 1.1 -- AIR - 18mm Graph

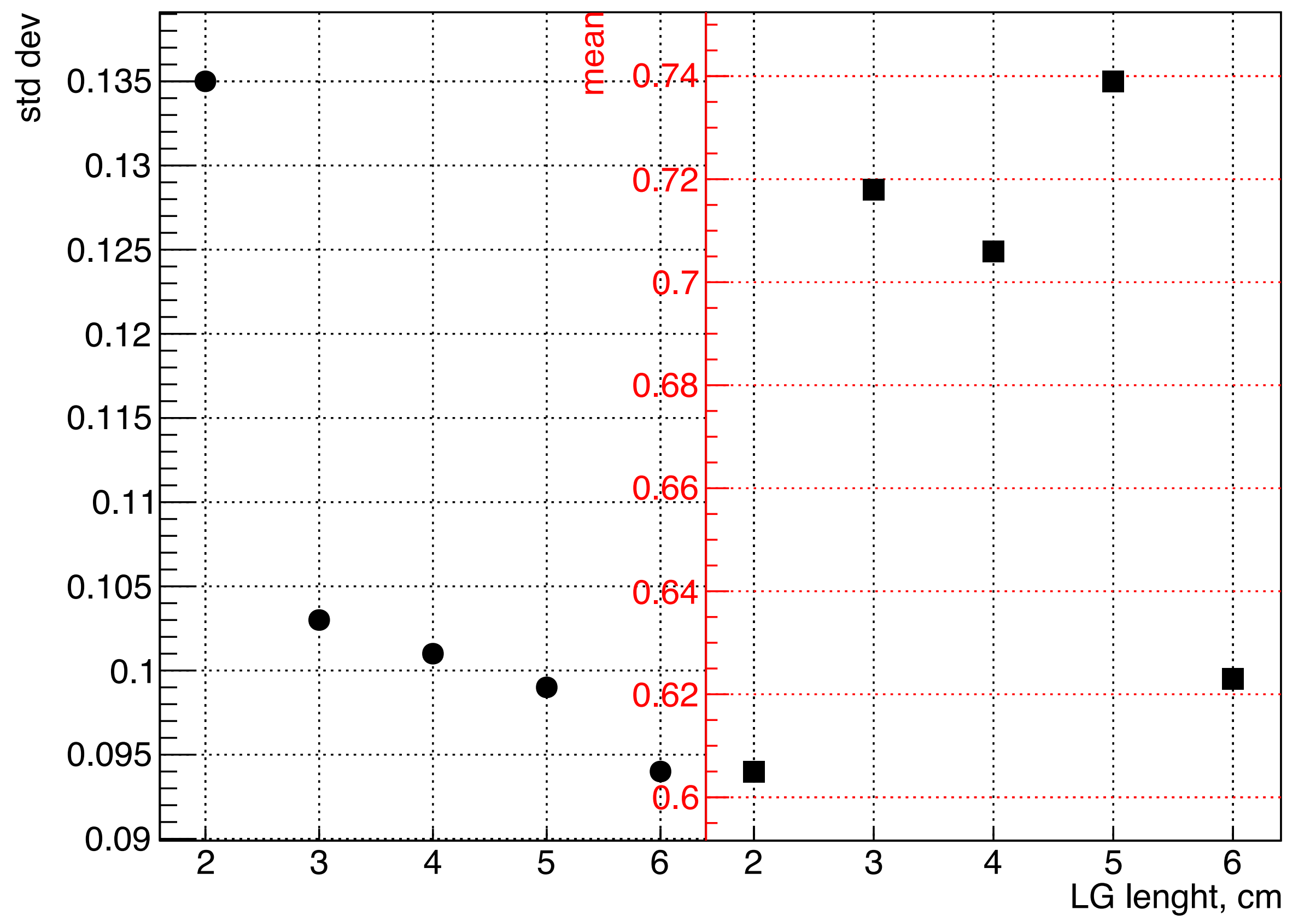

geometry 1.2

PMMA

Air

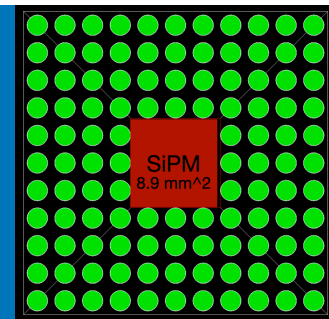

statistic 11.000 - muon 1 GeV

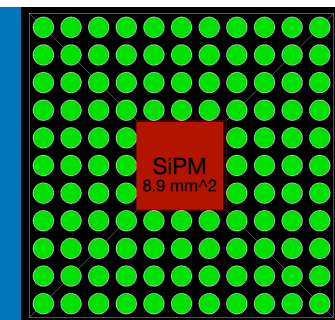

Efficiency - LG - PMMA - 2cm - base 8.9 mm

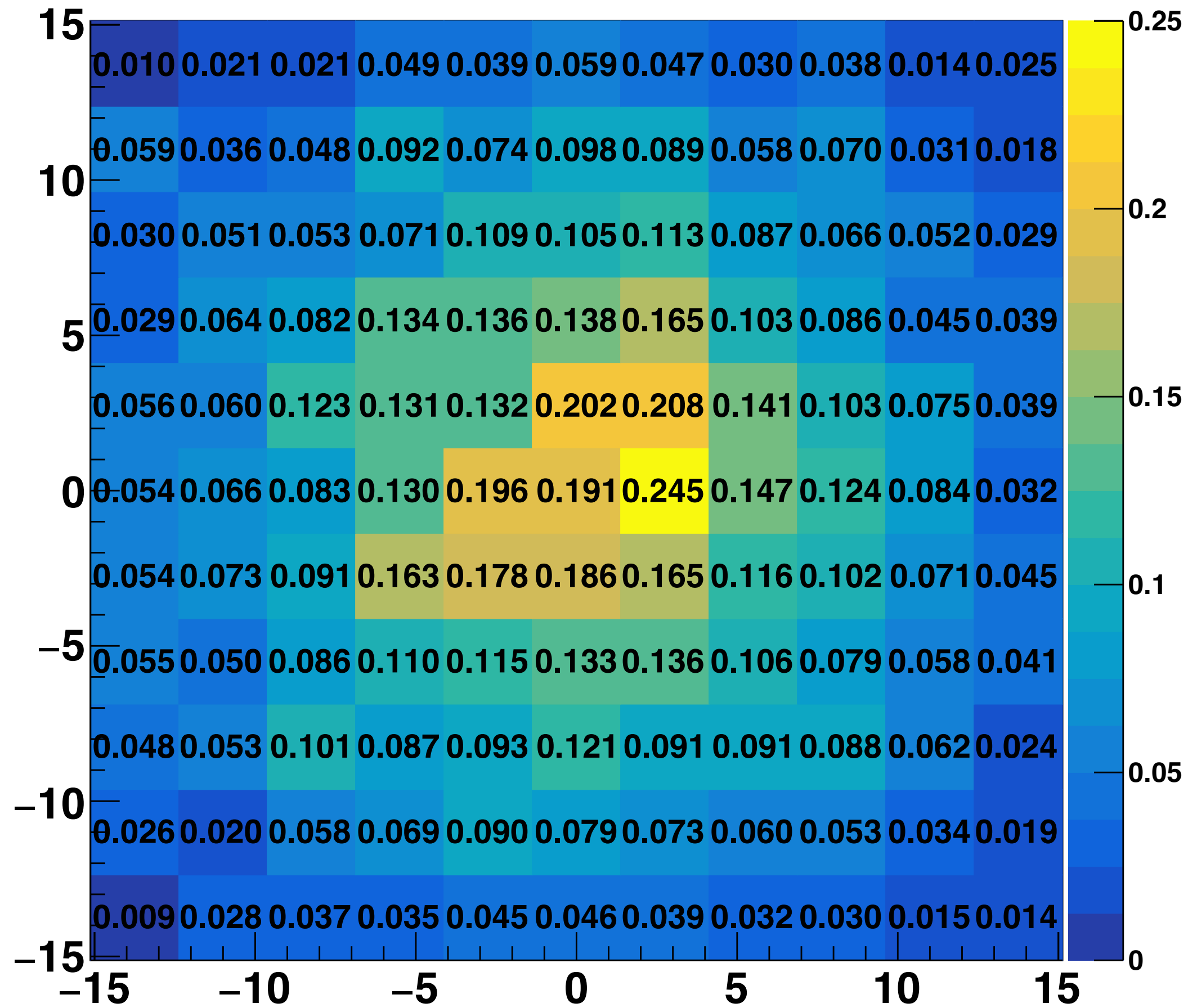

Factor non-uniformity - LG - PMMA - 2cm - base 8.9 mm

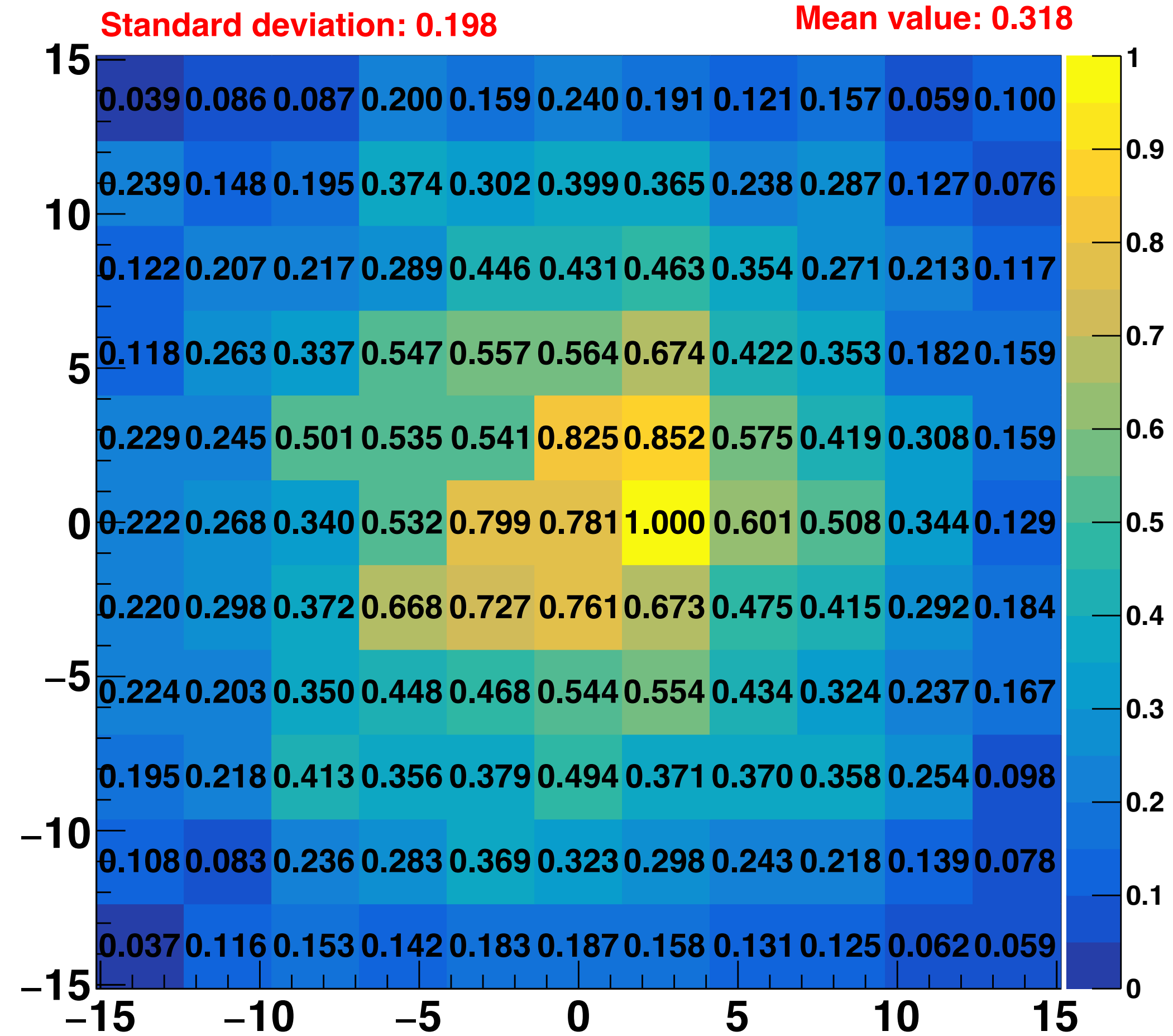

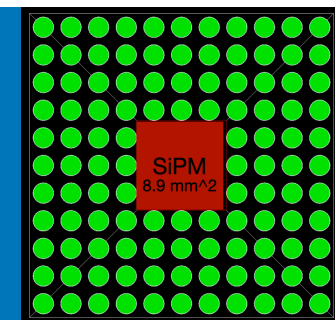

Efficiency - LG - PMMA - 3cm - base 8.9 mm

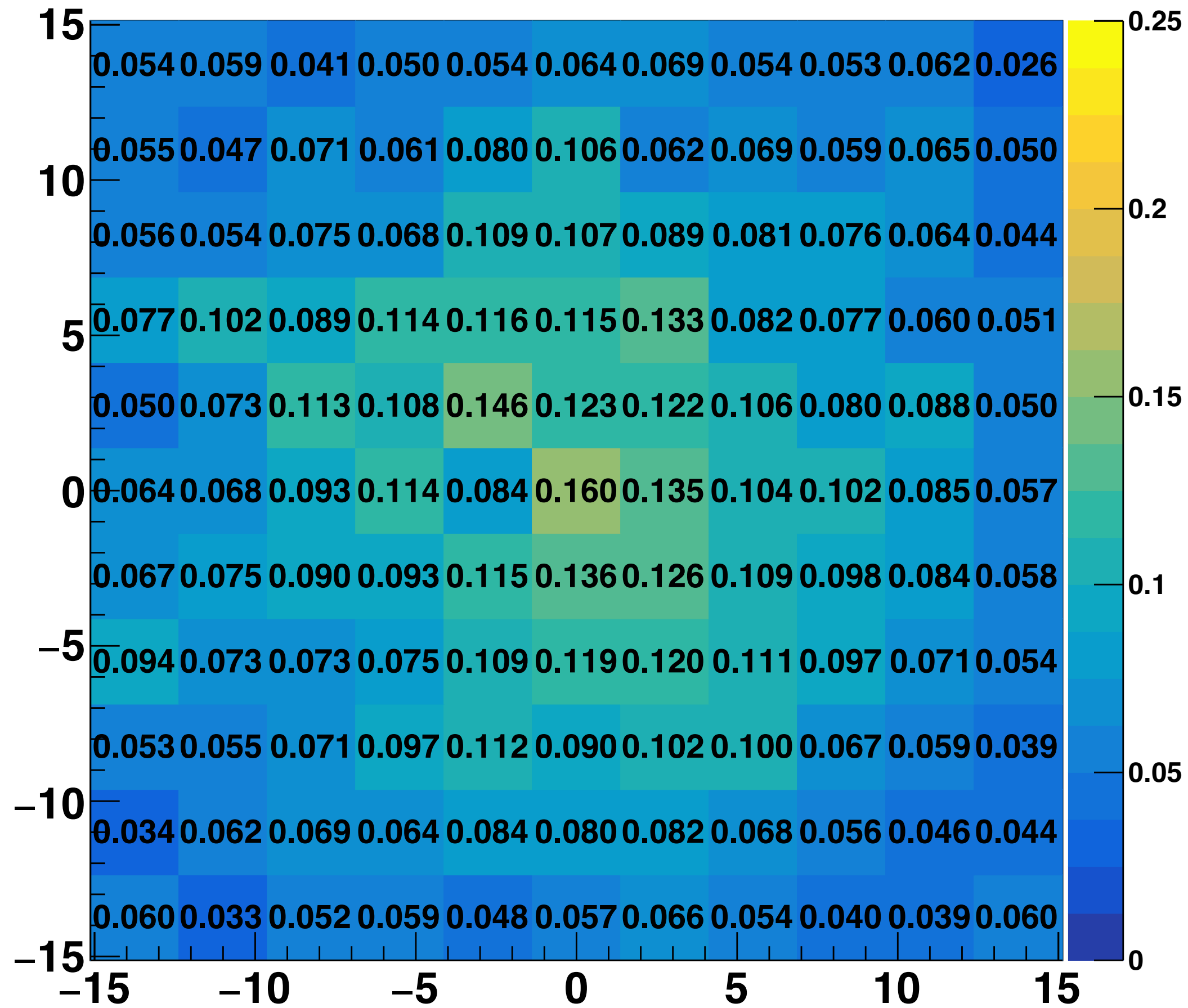

Factor non-uniformity - LG - PMMA - 3cm - base 8.9 mm

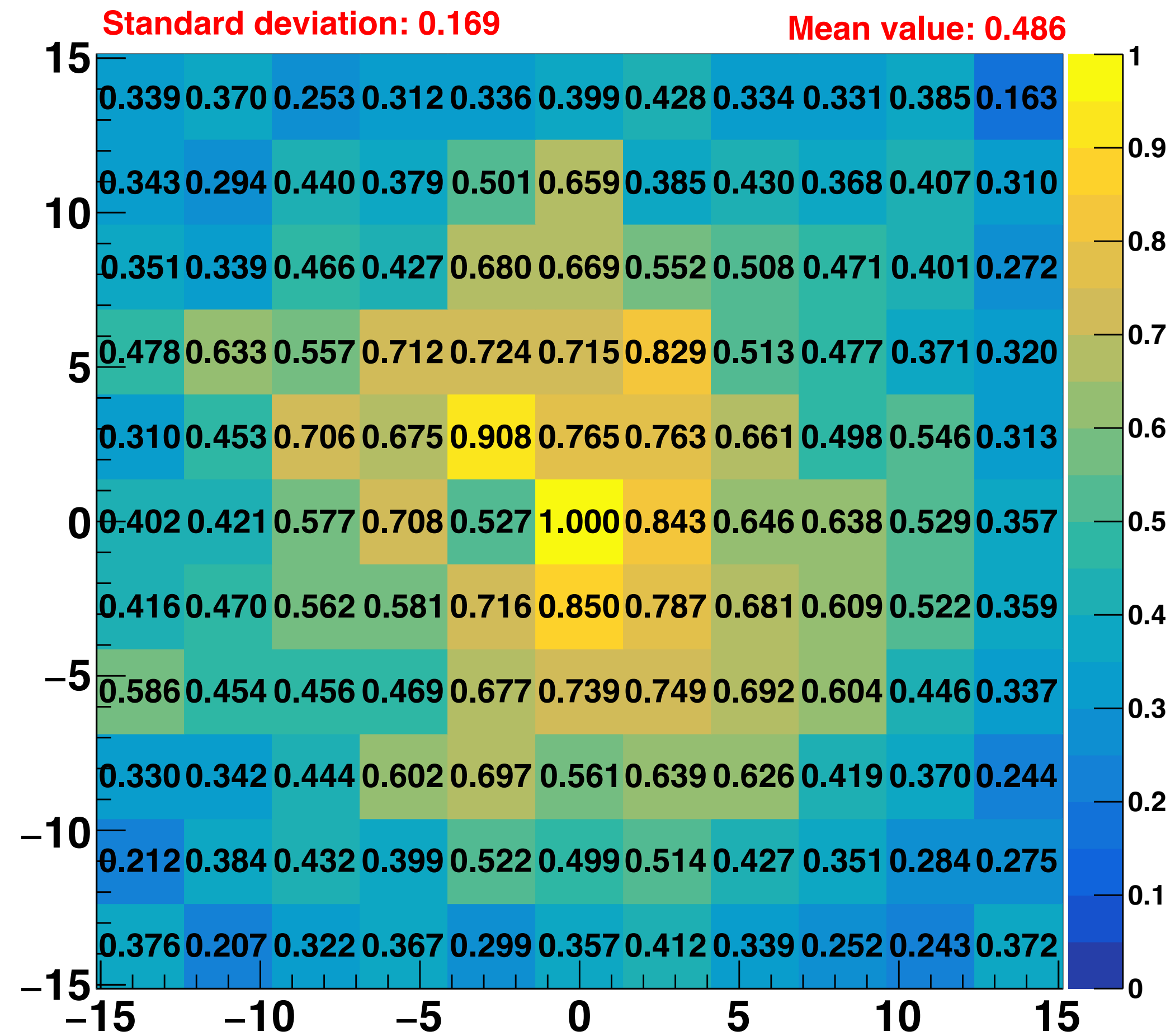

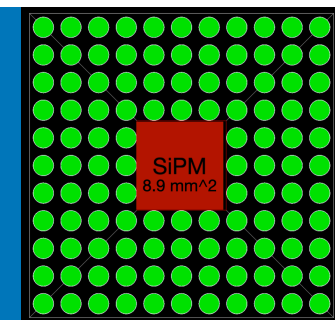

Efficiency - LG - PMMA - 4cm - base 8.9 mm

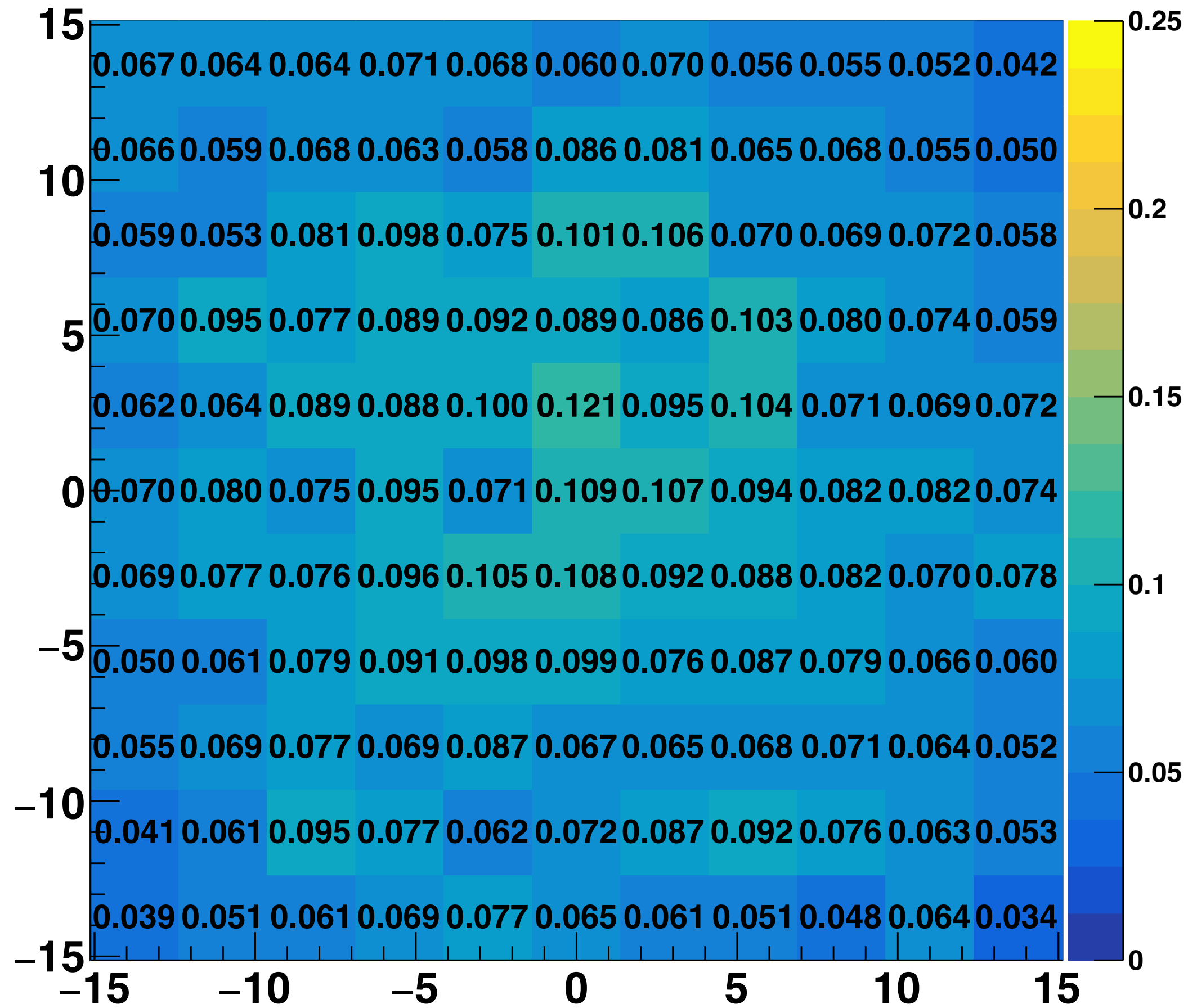

Factor non-uniformity - LG - PMMA - 4cm - base 8.9 mm

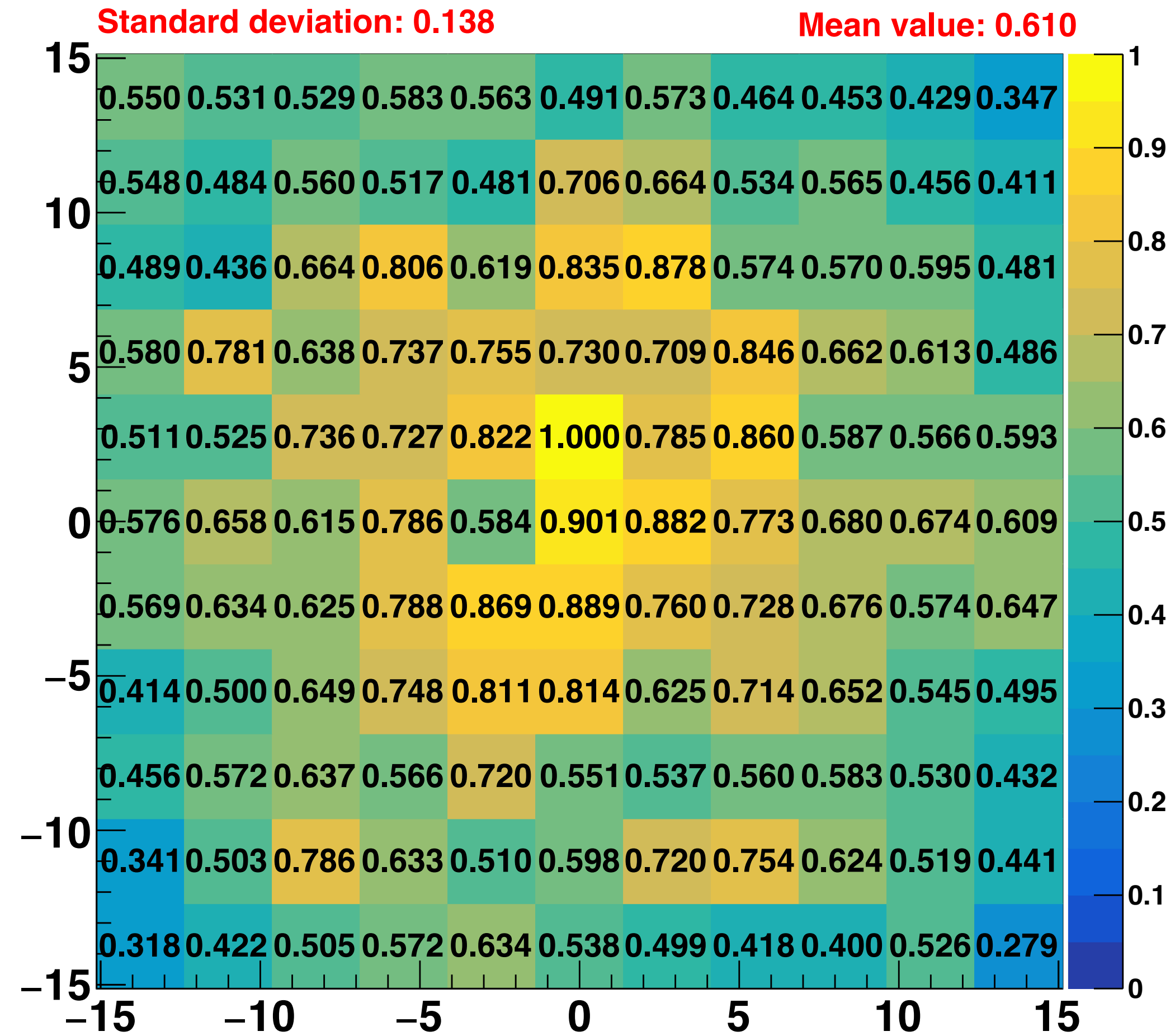

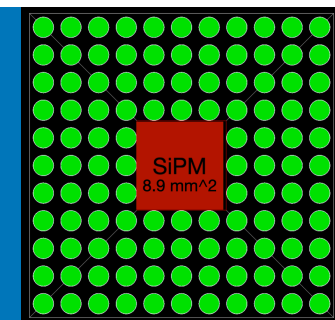

Efficiency - LG - PMMA - 5cm - base 8.9 mm

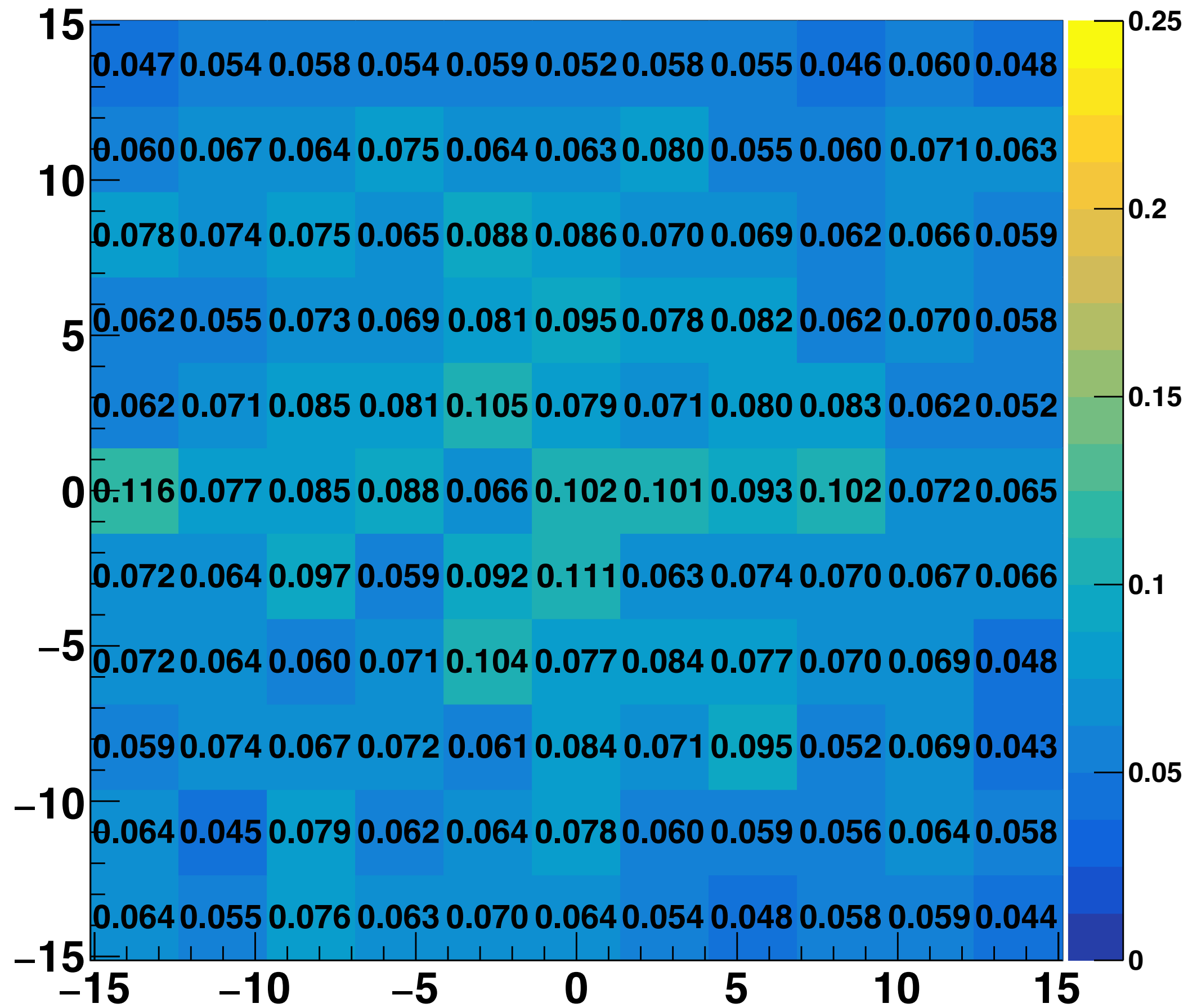

Factor non-uniformity - LG - PMMA - 5cm - base 8.9 mm

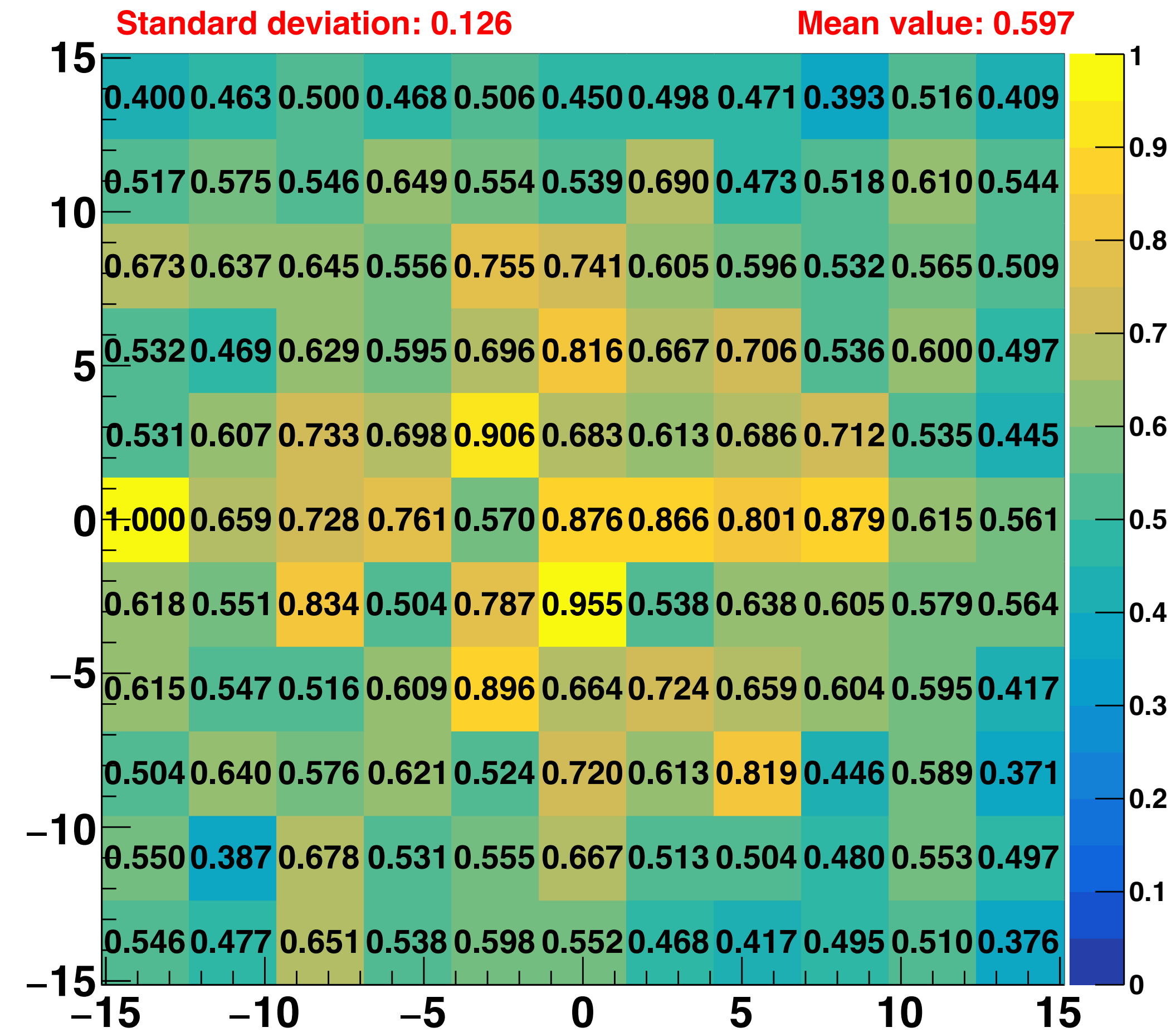

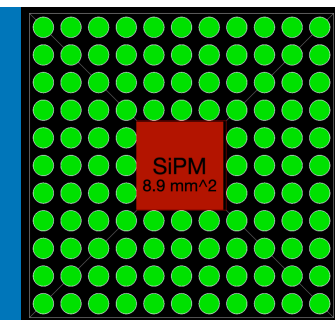

Efficiency - LG - PMMA - 6cm - base 8.9 mm

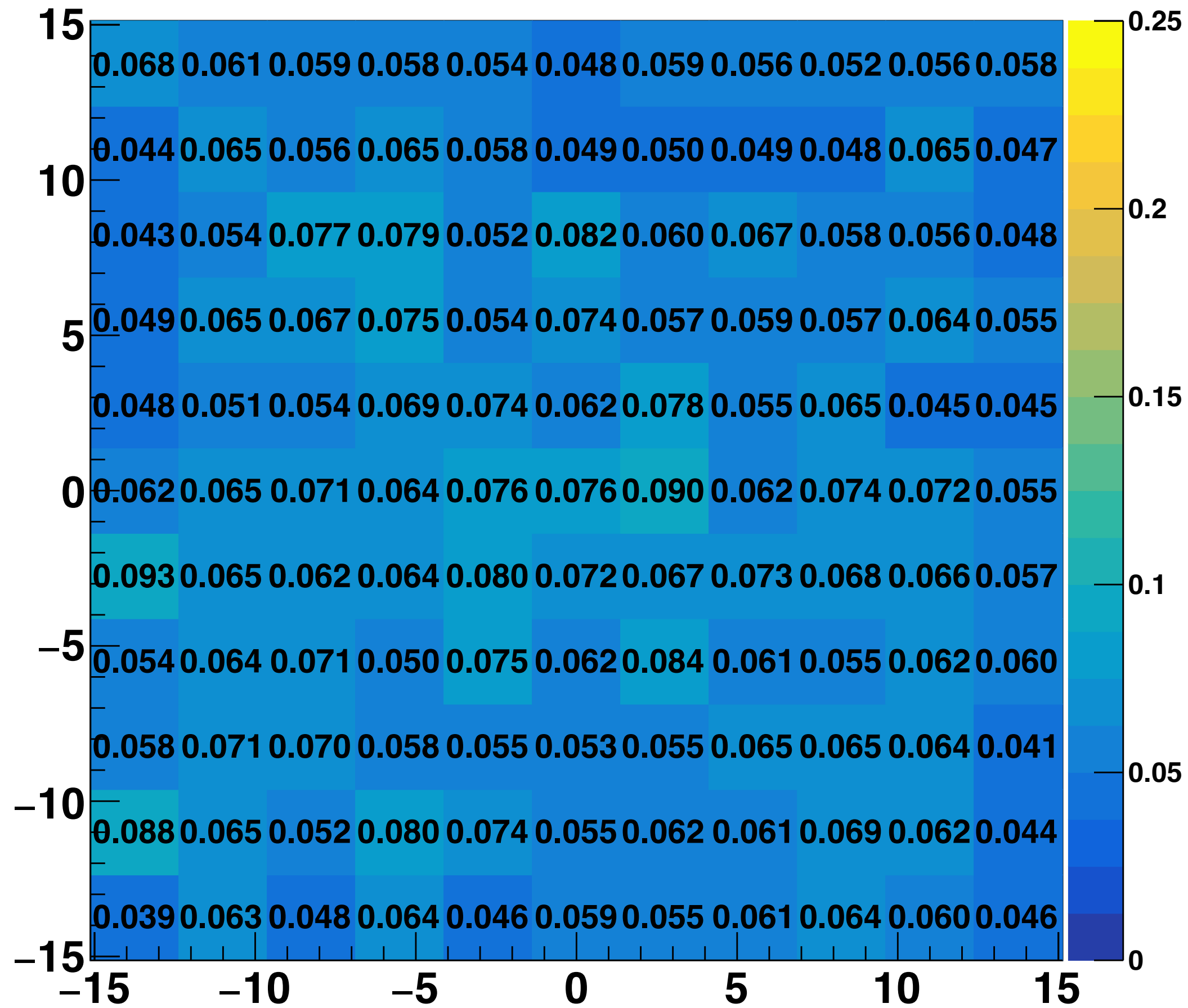

Factor non-uniformity - LG - PMMA - 6cm - base 8.9 mm

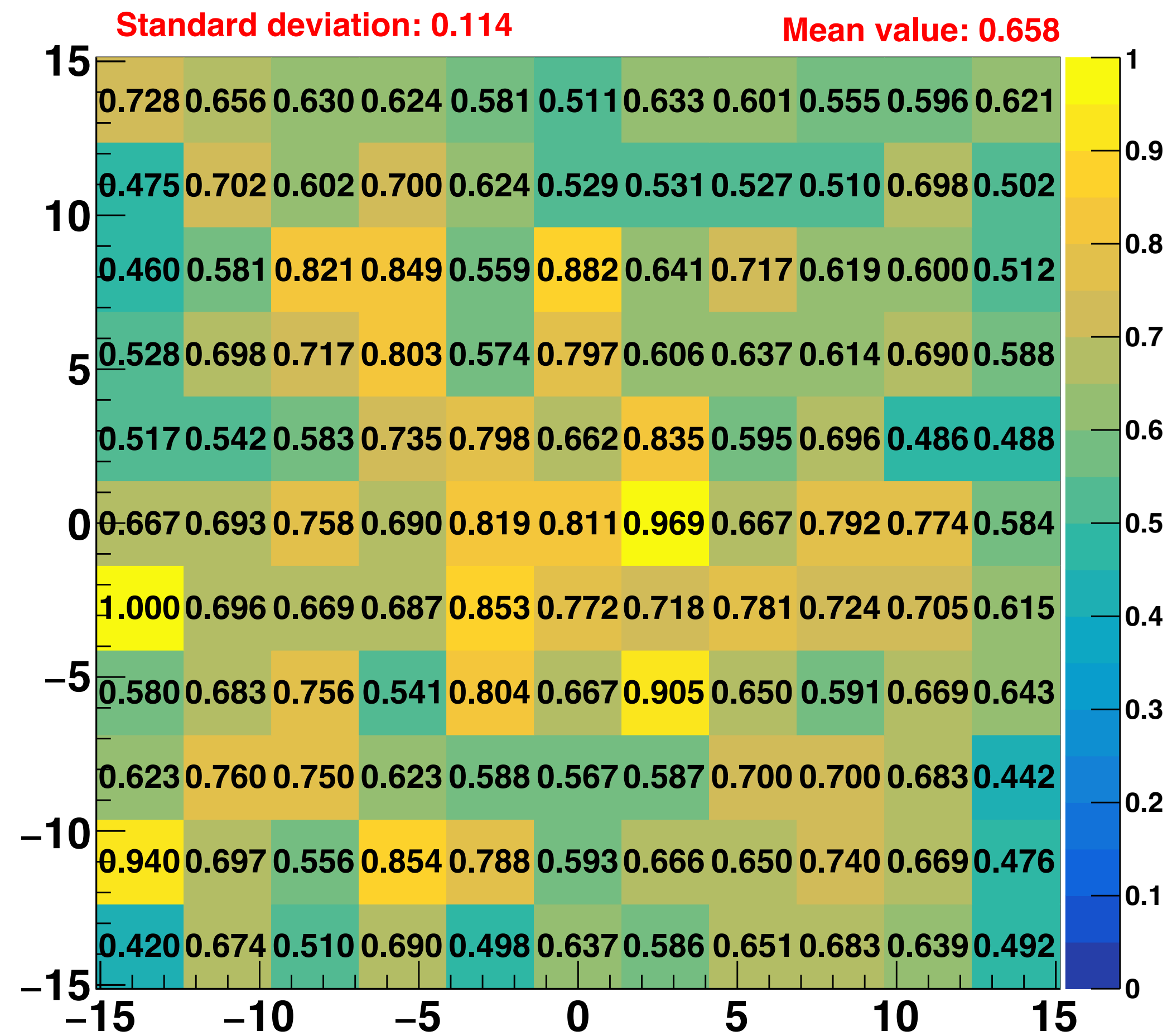

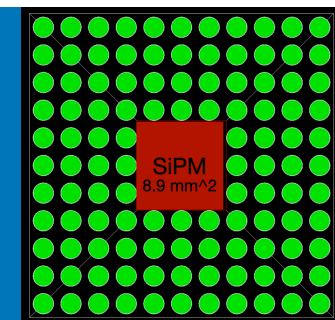

Efficiency - LG - Air - 2cm - base 8.9 mm

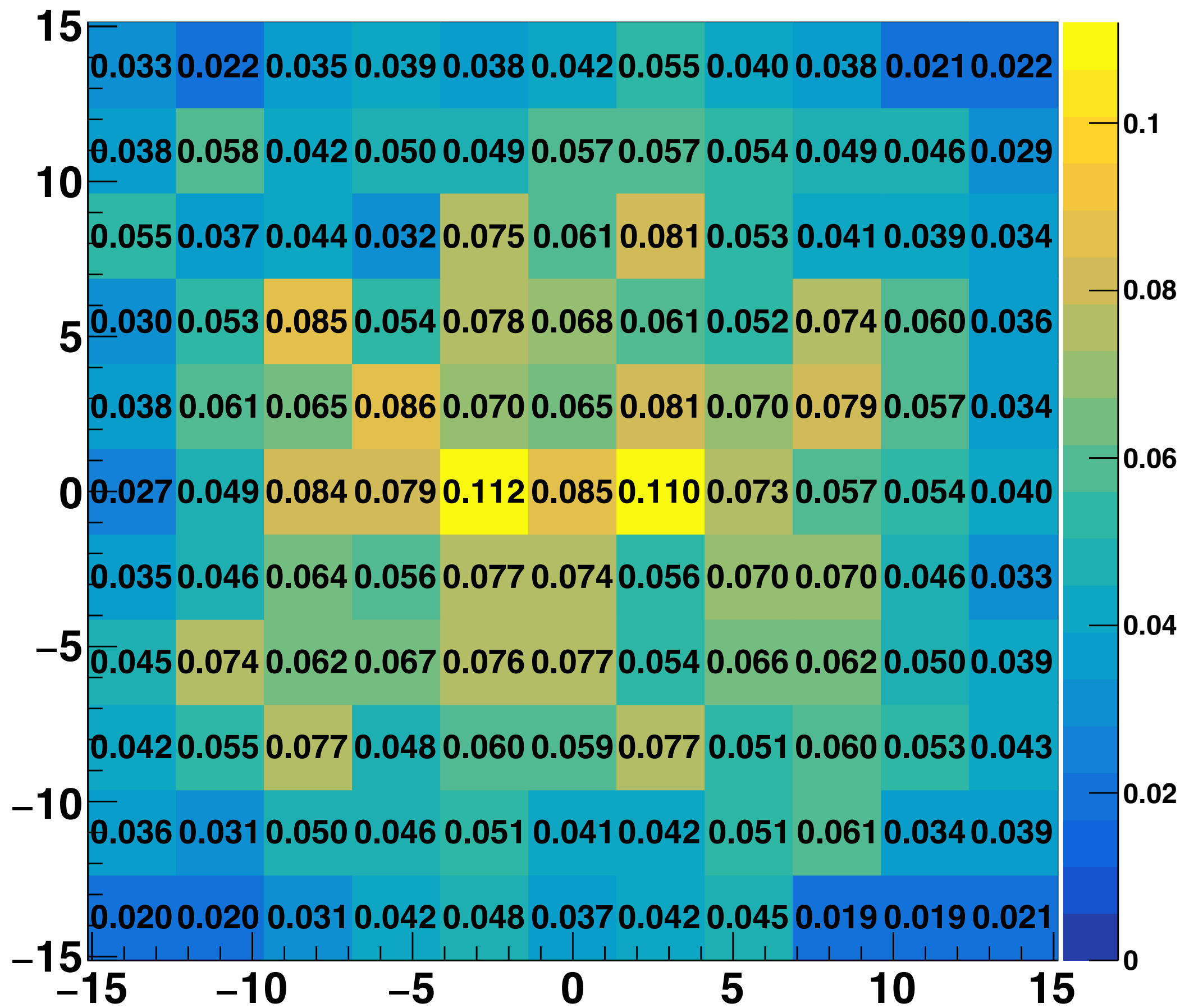

Factor non-uniformity - LG - AIR - 2cm - base 8.9 mm

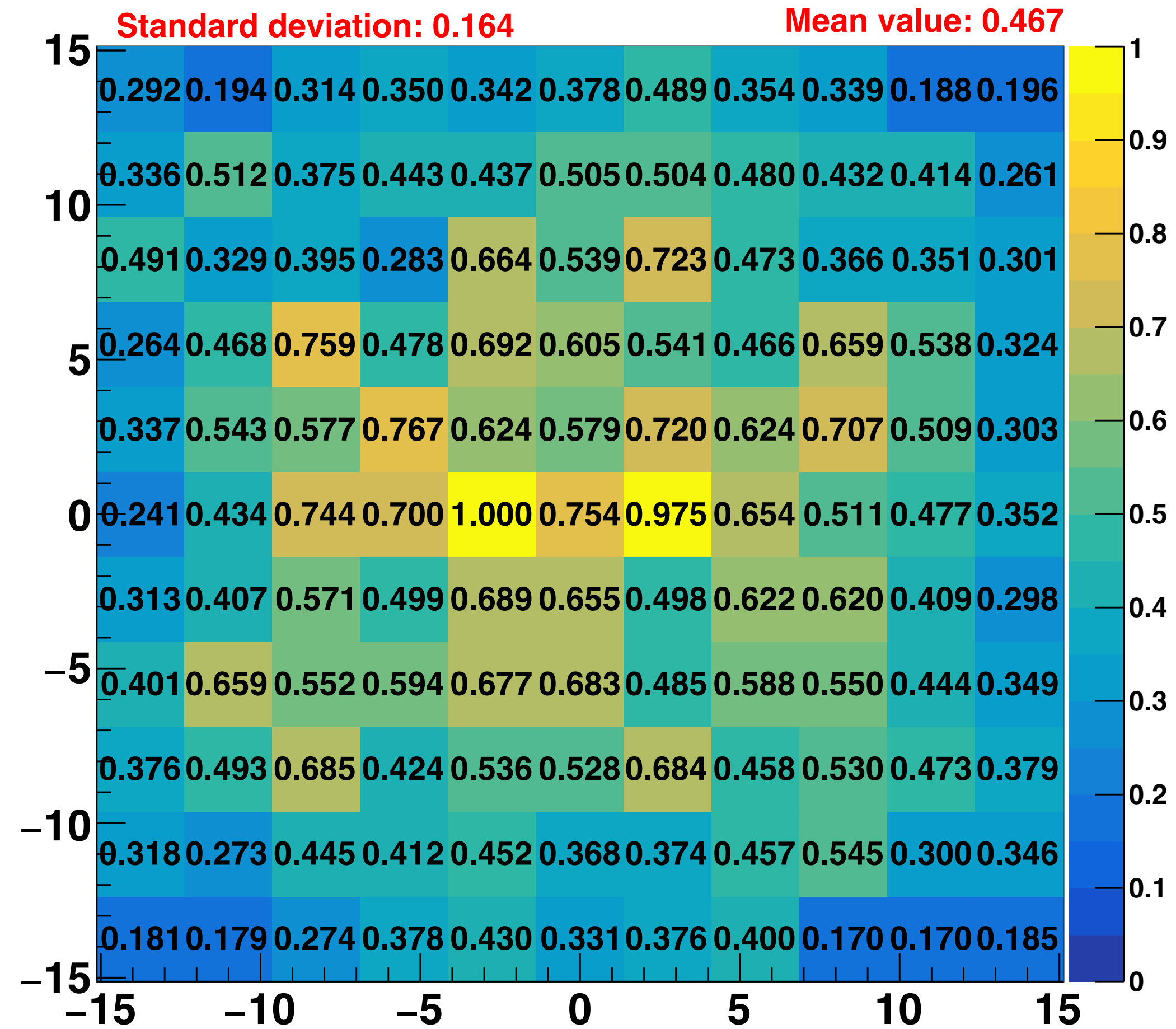

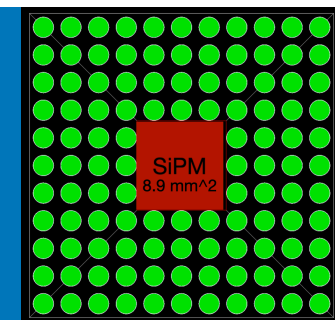

Efficiency - LG - Air - 3cm - base 8.9 mm

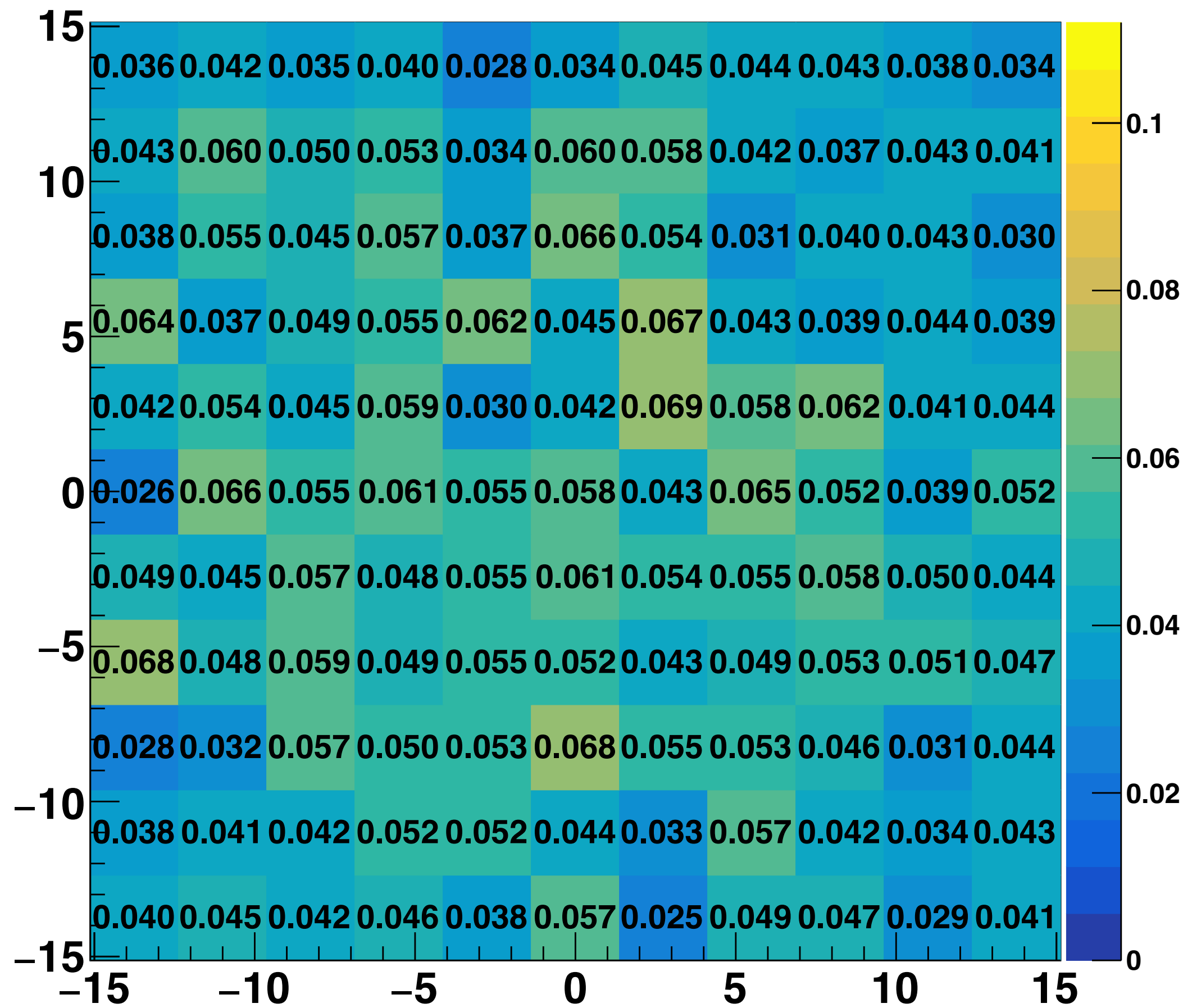

Factor non-uniformity - LG - AIR - 3cm - base 8.9 mm

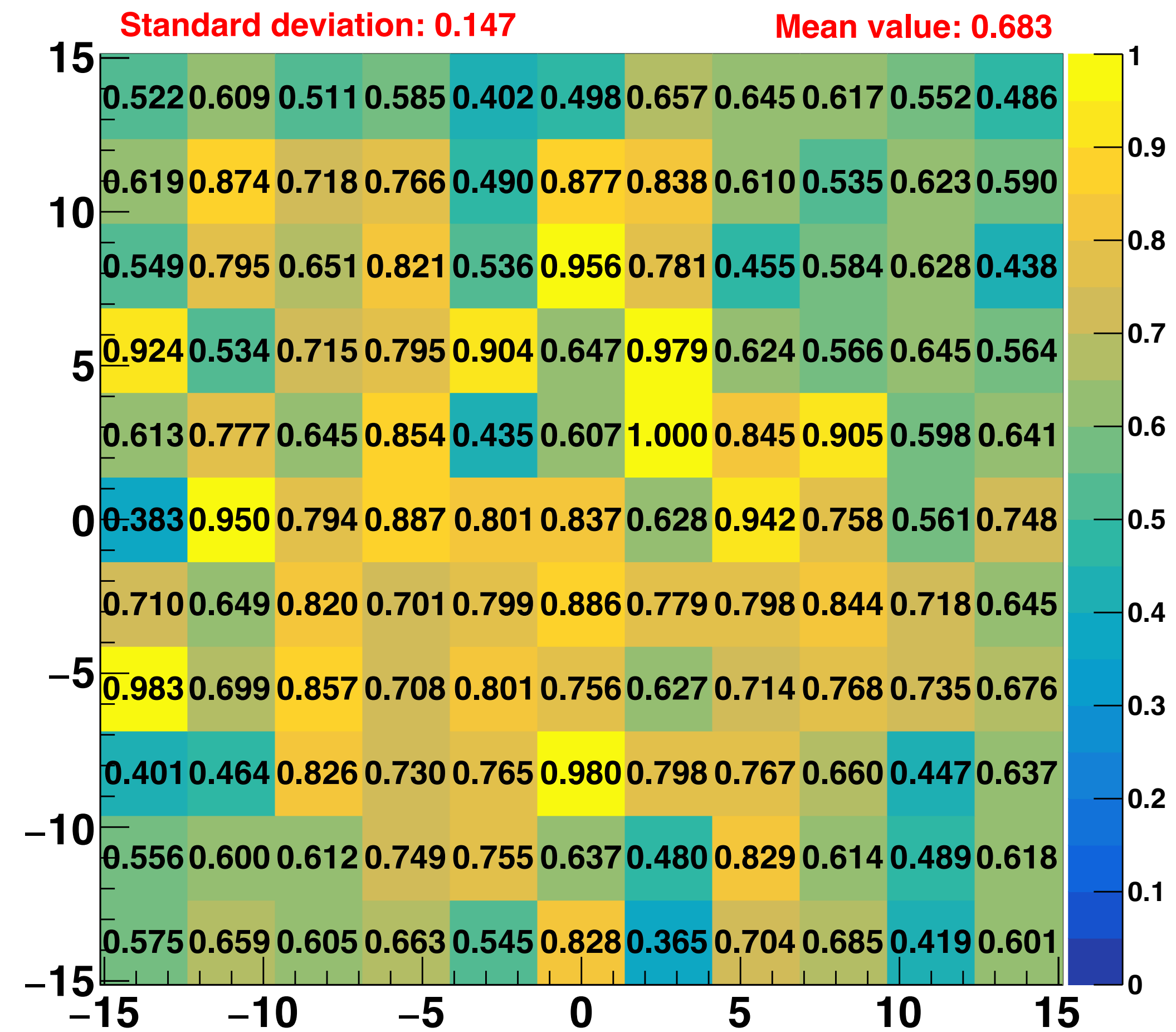

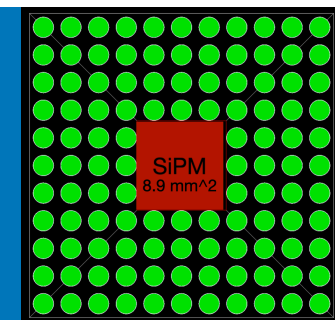

Efficiency - LG - Air - 4cm - base 8.9 mm

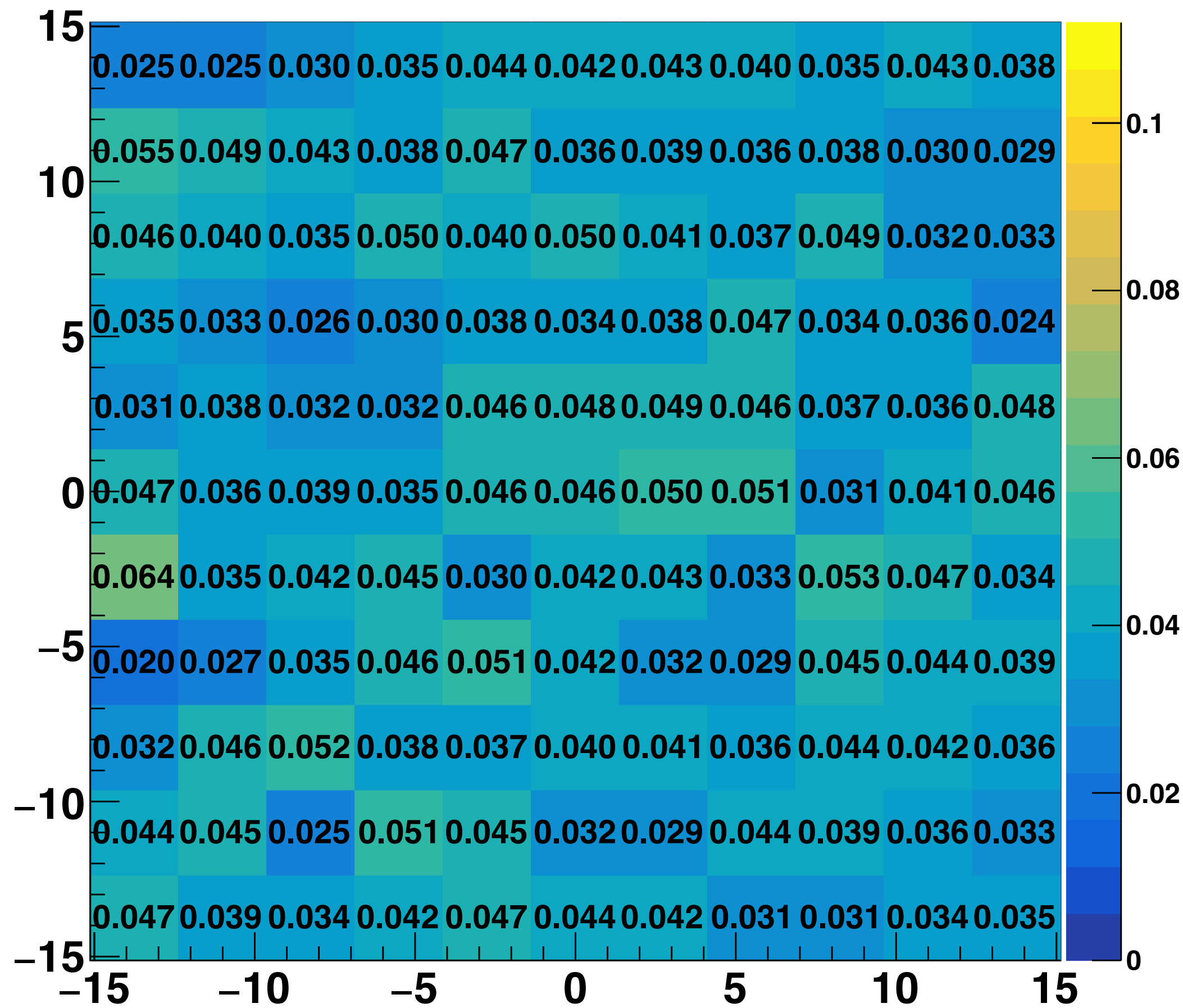

Factor non-uniformity - LG - AIR - 4cm - base 8.9 mm

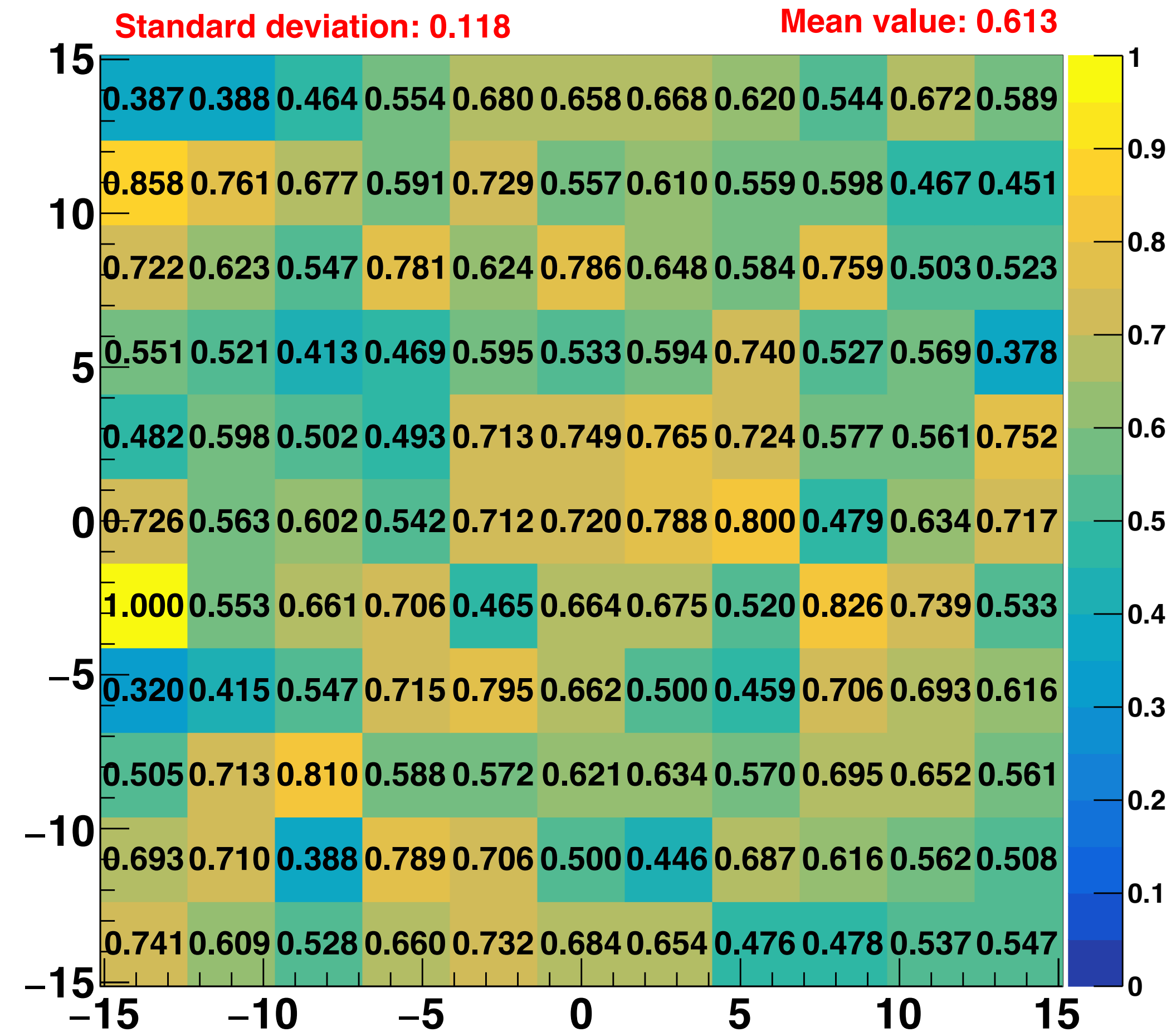

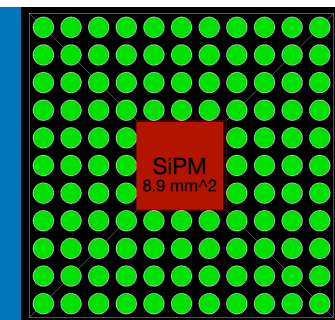

Efficiency - LG - Air - 5cm - base 8.9 mm

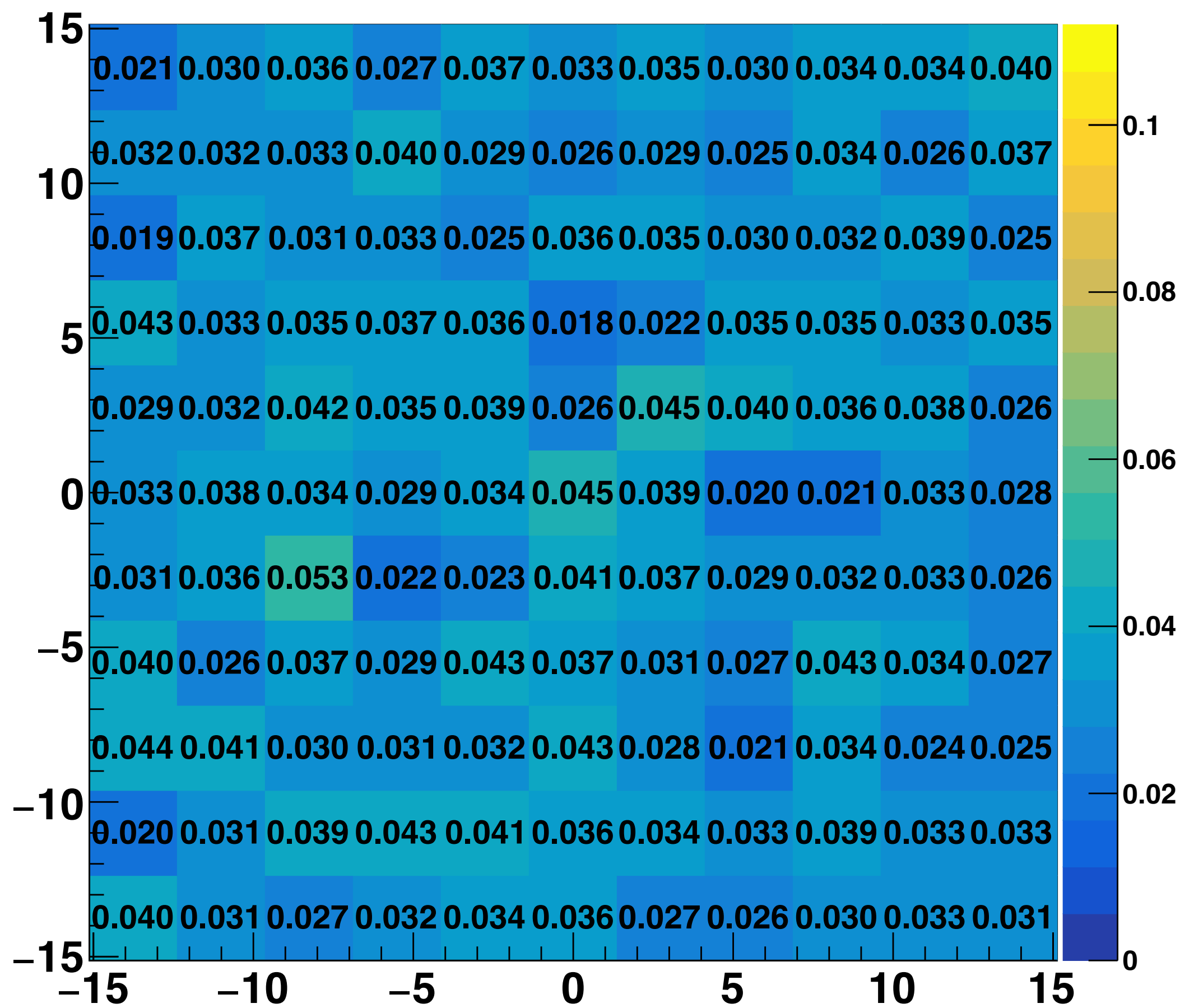

Factor non-uniformity - LG - AIR - 5cm - base 8.9 mm

Standard deviation: 0.121

Mean value: 0.624

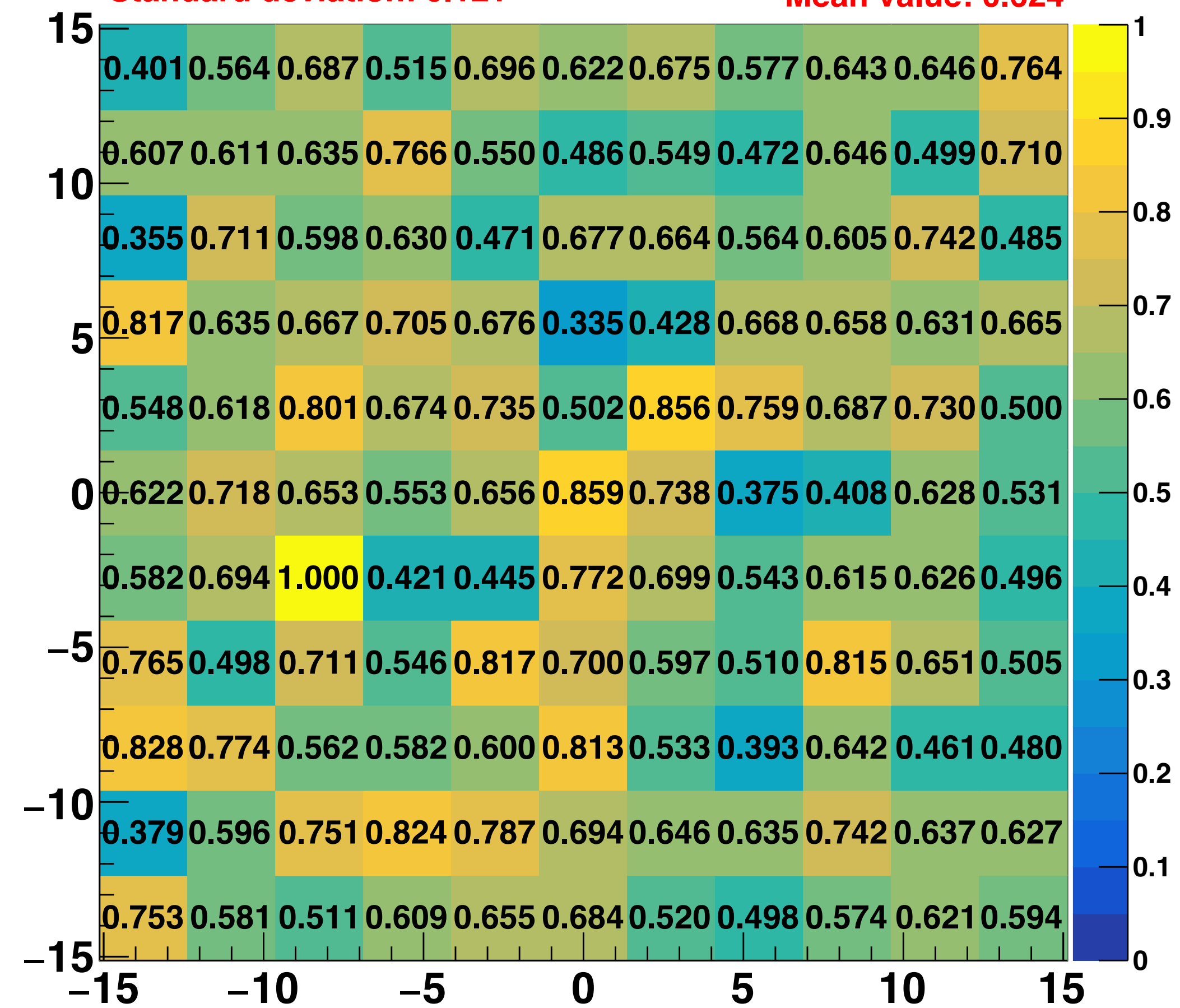

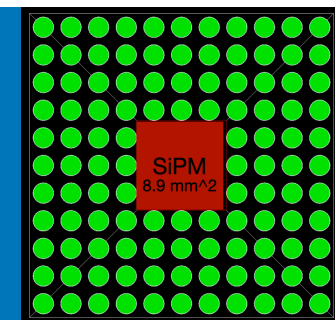

Efficiency - LG - Air - 6cm - base 8.9 mm

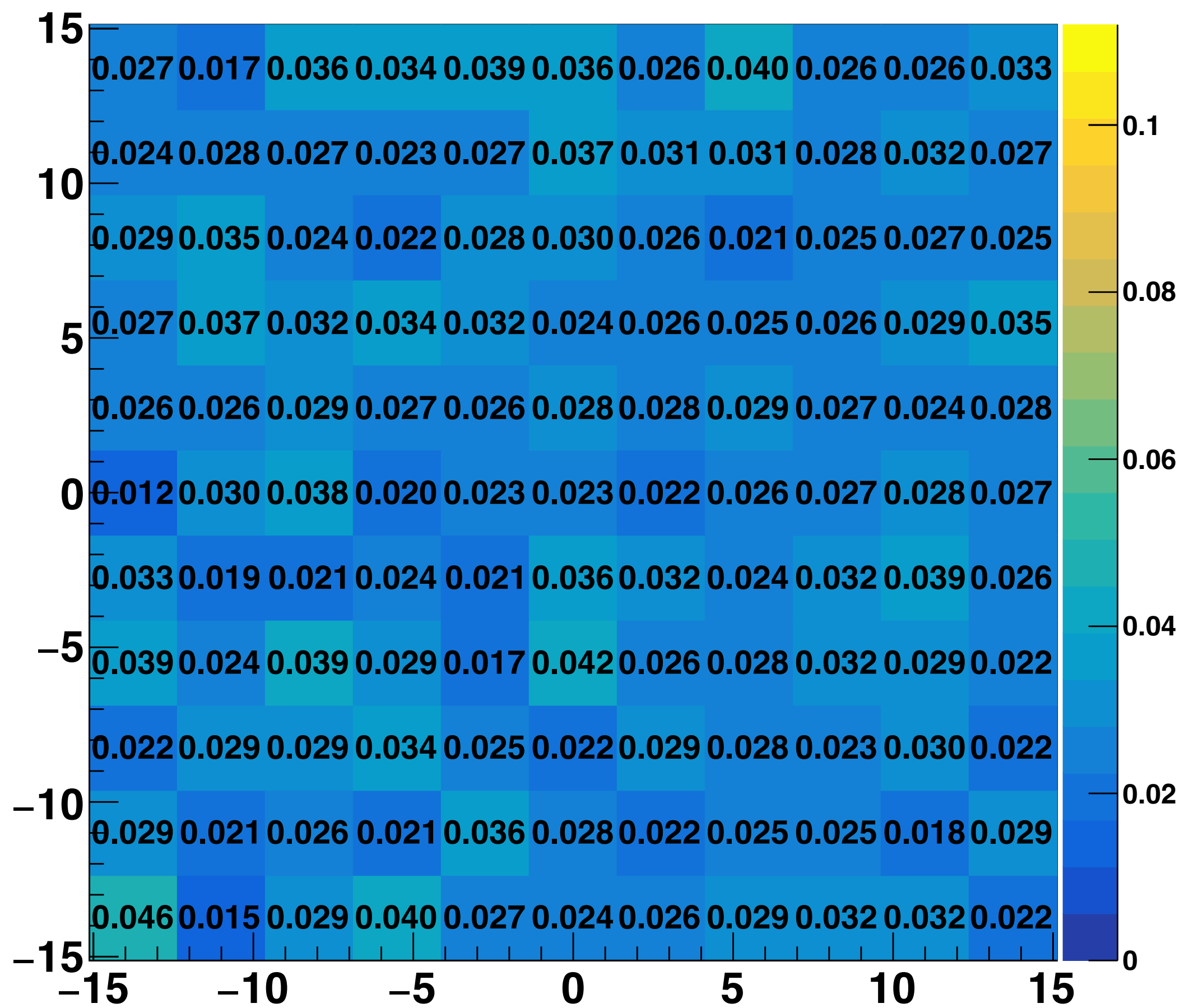

Factor non-uniformity - LG - AIR - 6cm - base 8.9 mm

Standard deviation: 0.124

Mean value: 0.605

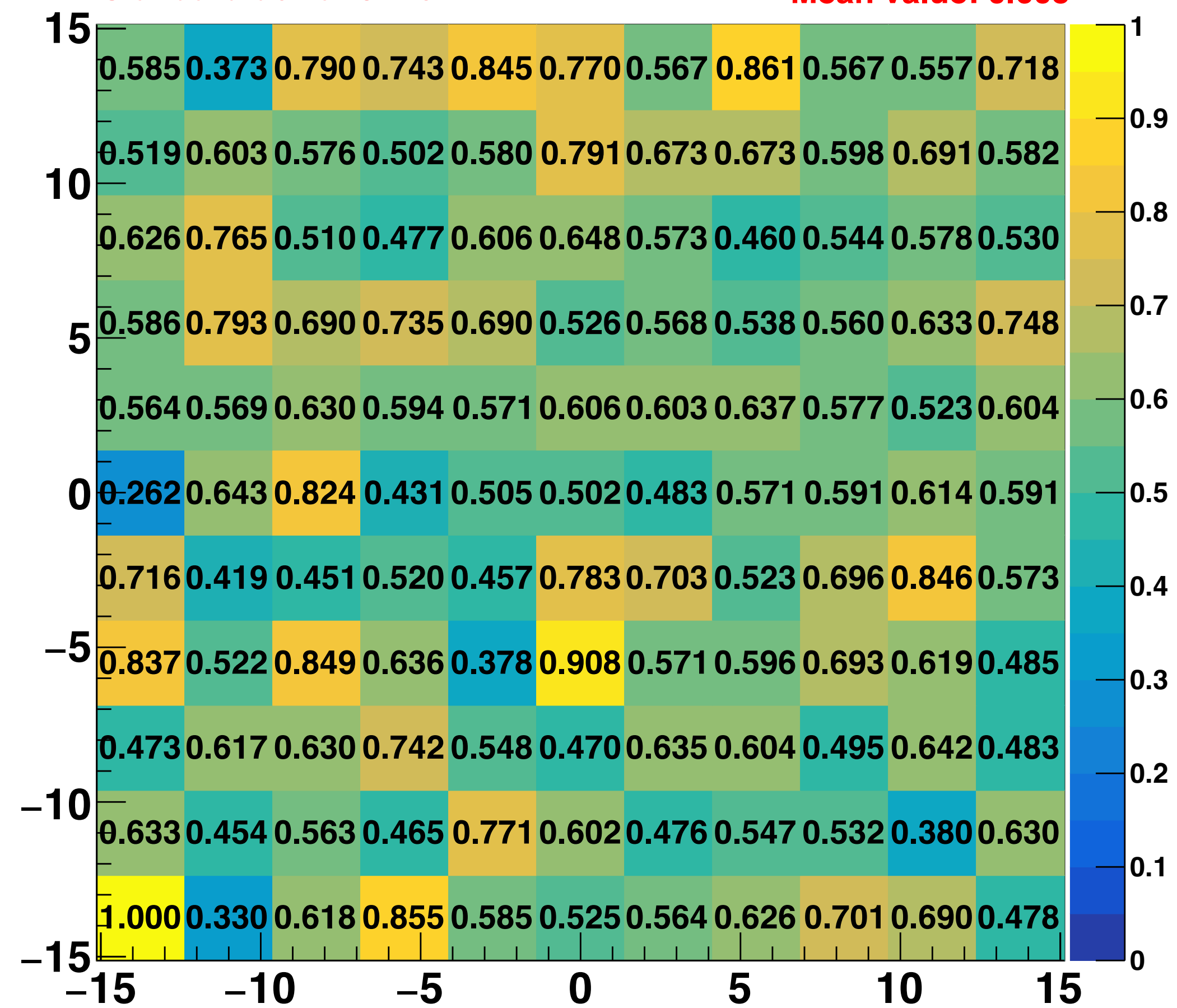

Geometry 1.2 -- PMMA - 8.9mm GI

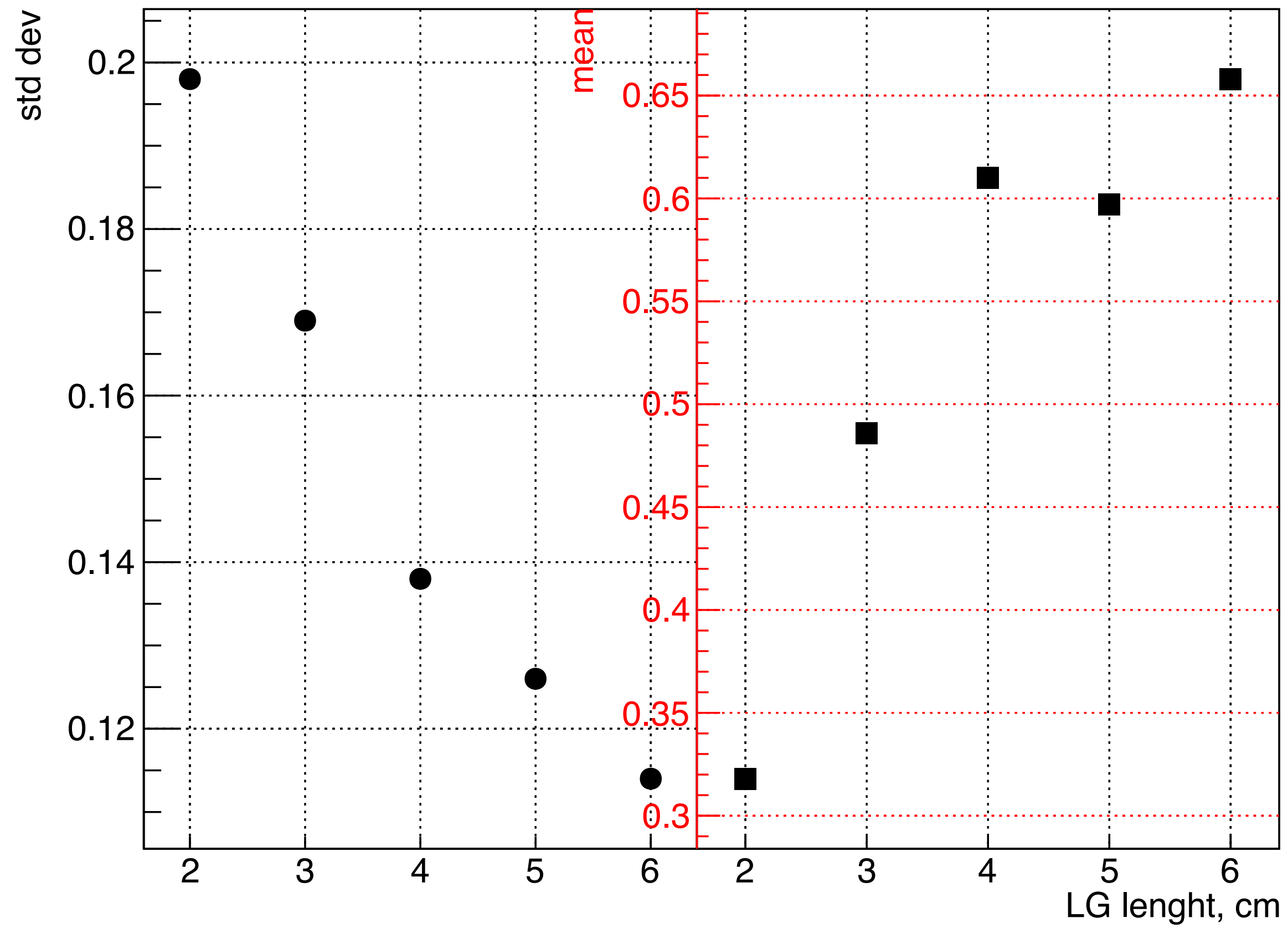

Geometry 1.2 -- AIR - 8.9mm Graph

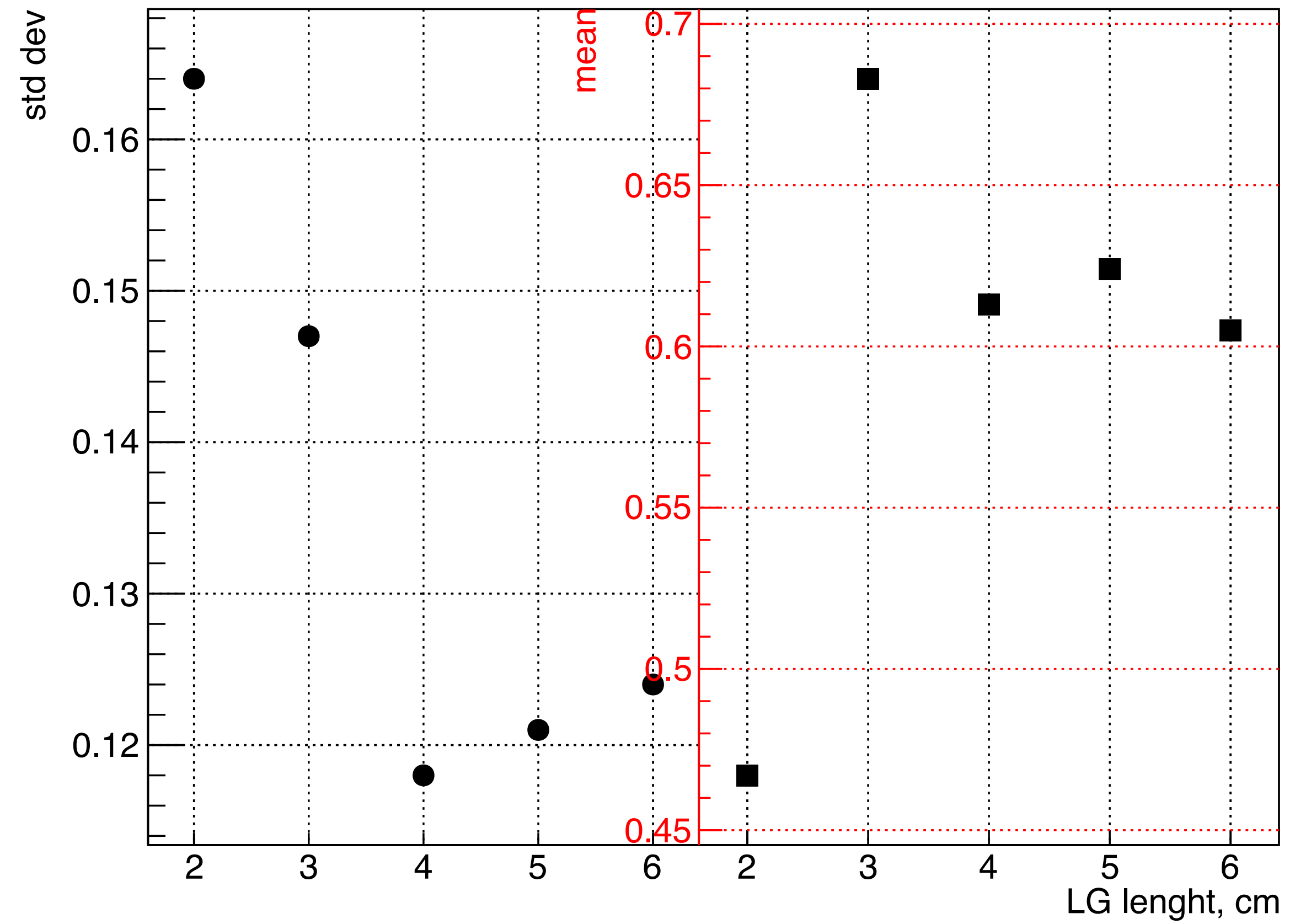

geometry 3

PMMA

Air

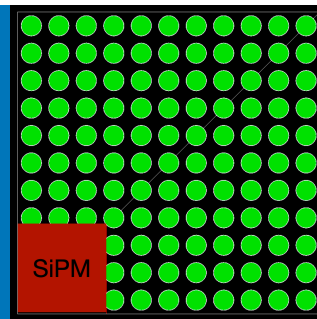

statistic 11.000 - muon 1 GeV

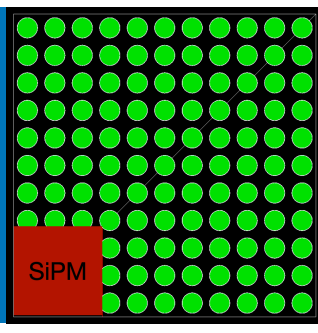

Efficiency - LG - PMMA - 2cm - base 8.9 mm

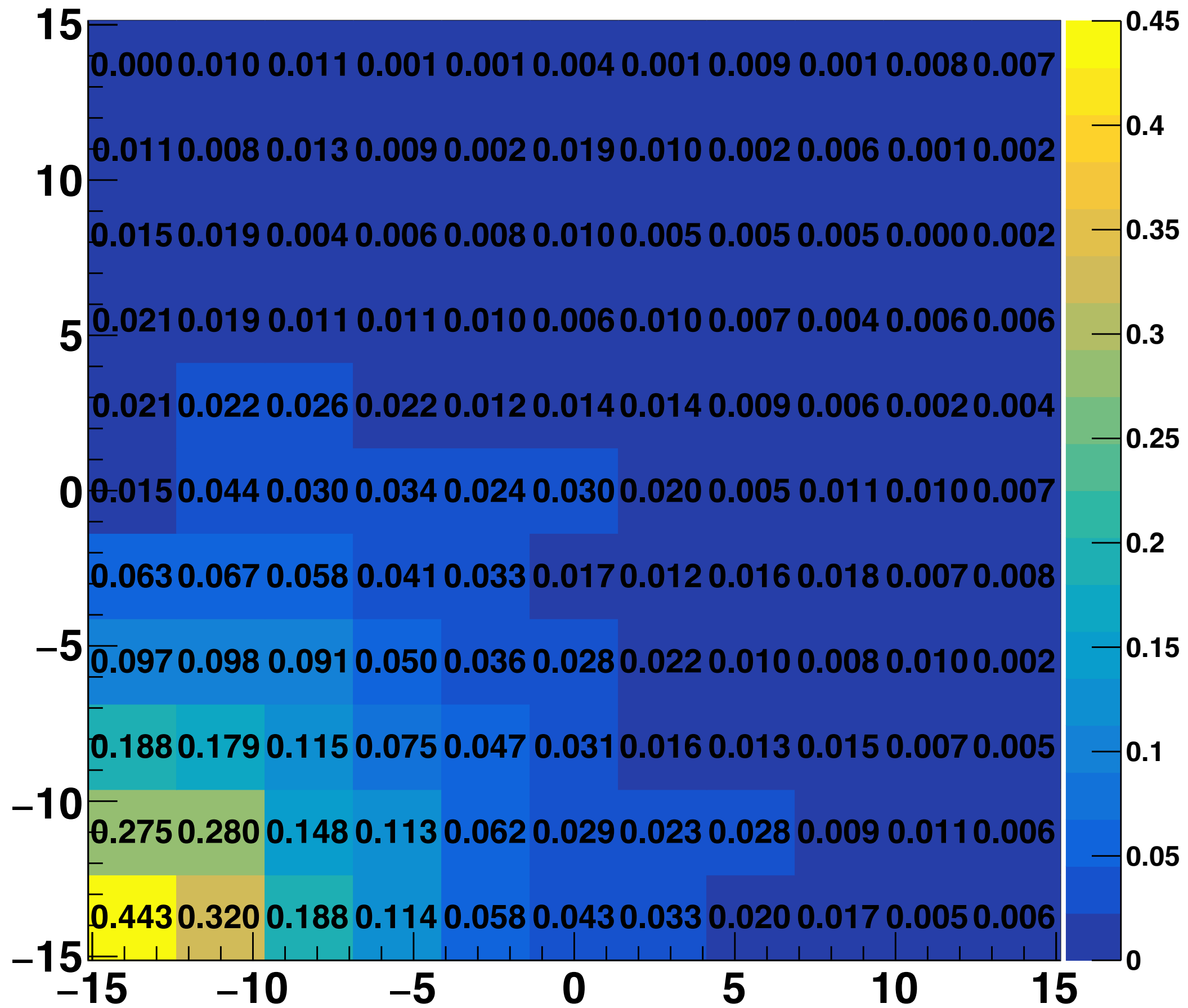

Factor non-uniformity - LG - PMMA - 2cm - base 8.9 mm

Standard deviation: 0.150 Mean value: 0.082

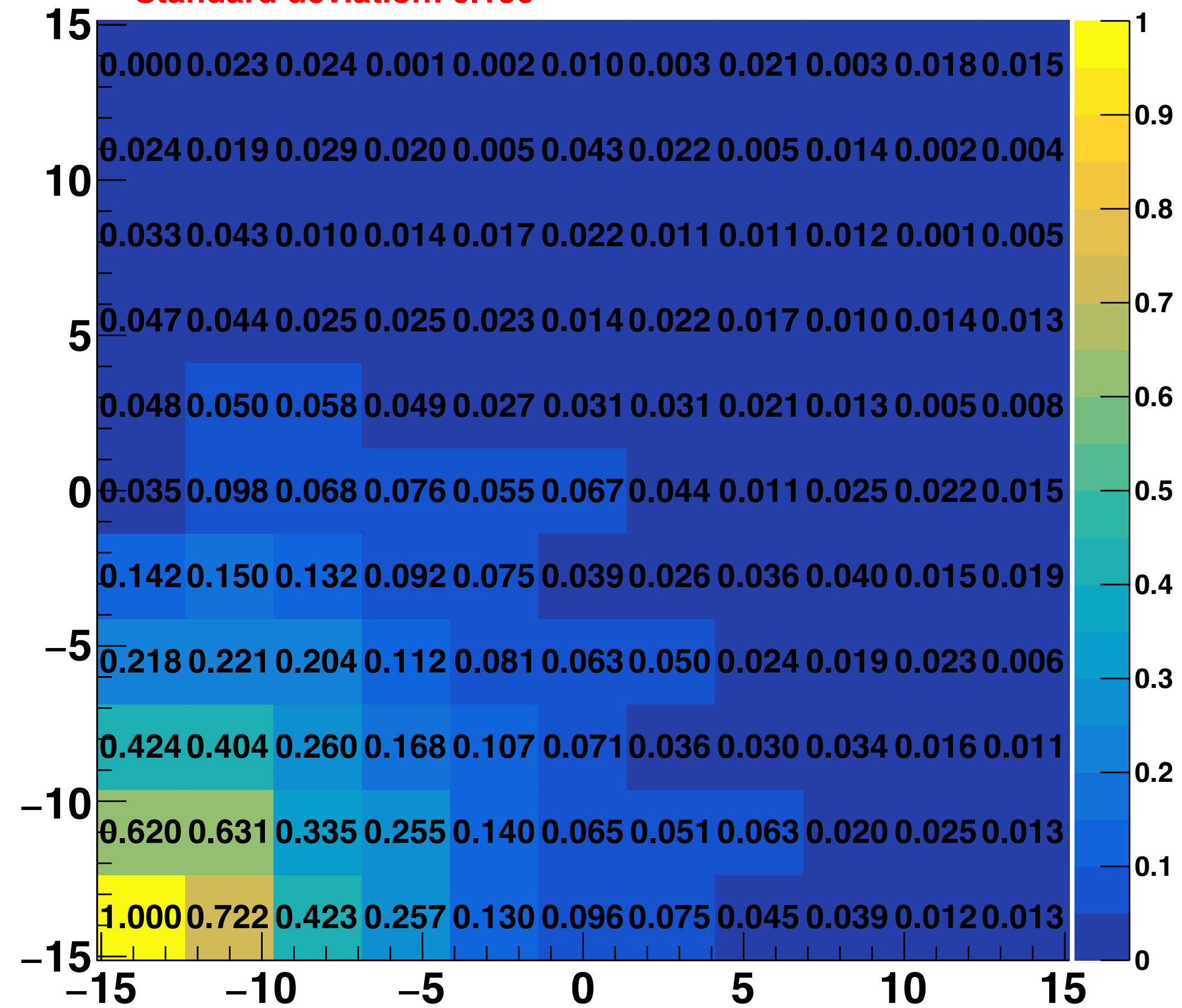

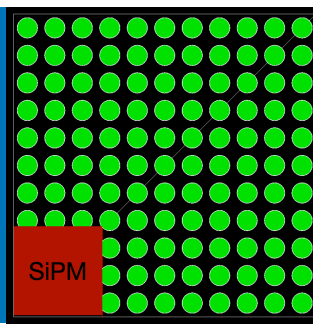

Efficiency - LG - PMMA - 3cm - base 8.9 mm

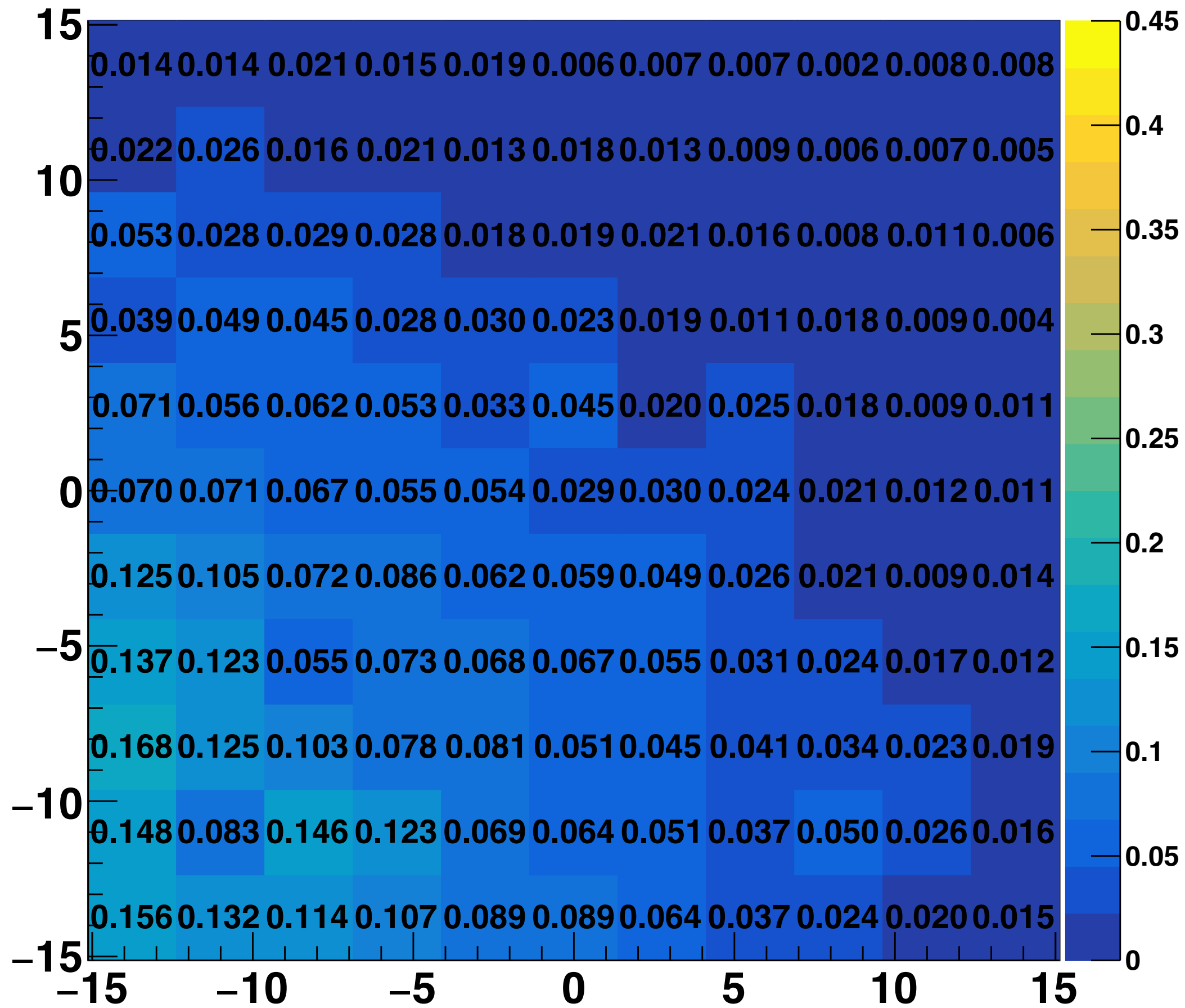

Factor non-uniformity - LG - PMMA - 3cm - base 8.9 mm

Standard deviation: 0.229 Mean value: 0.264

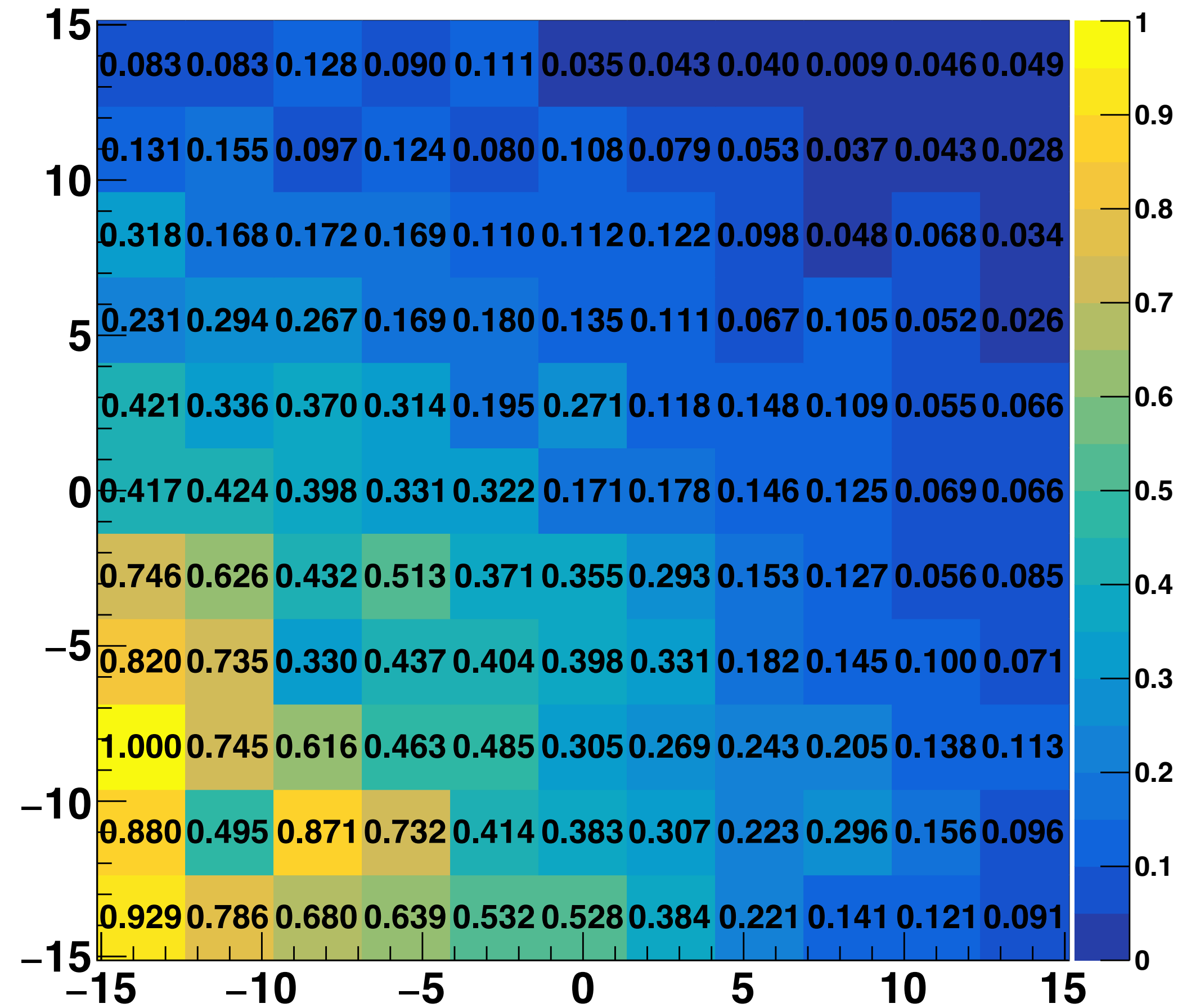

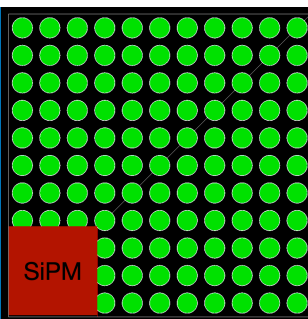

Efficiency - LG - PMMA - 4cm - base 8.9 mm

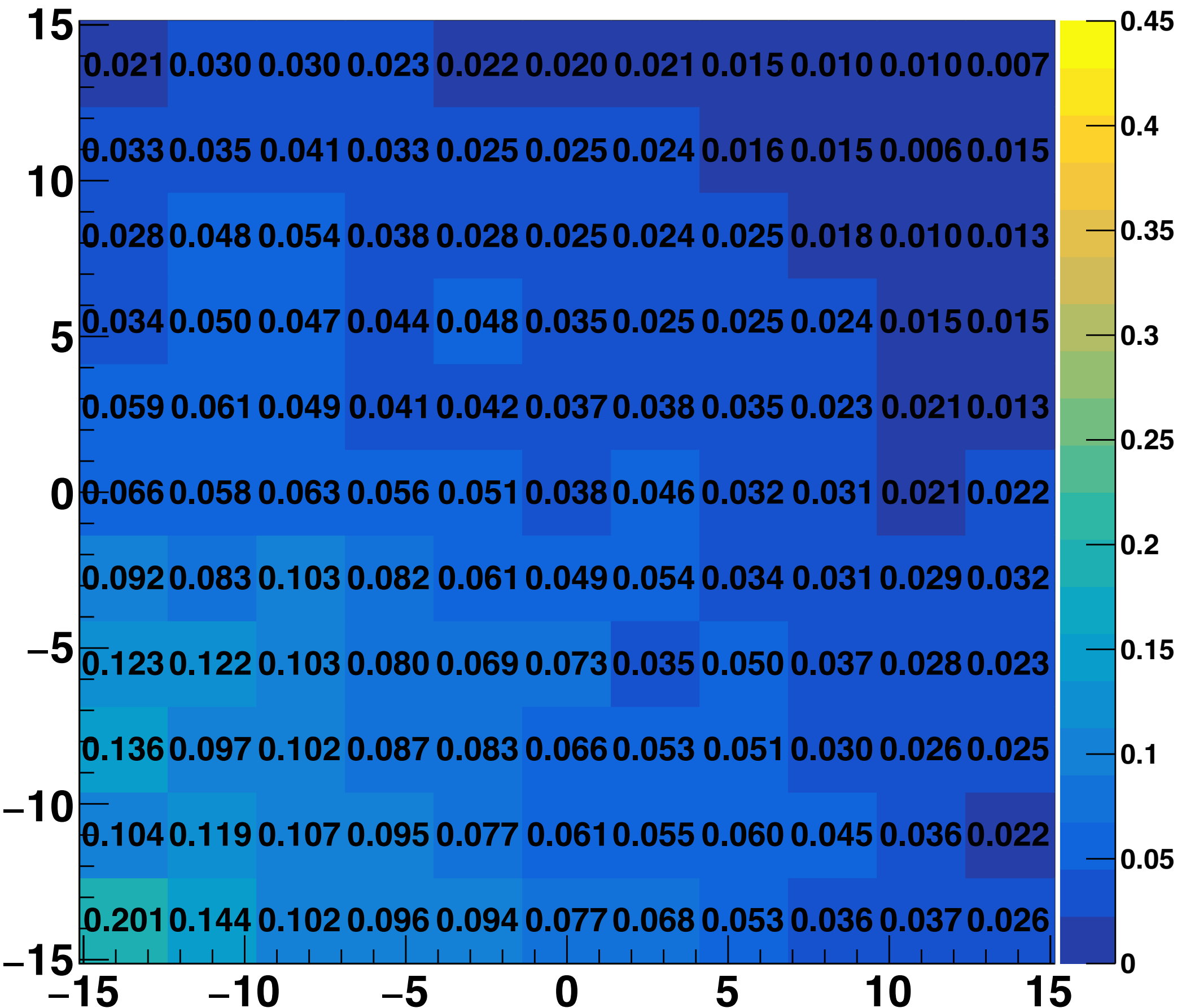

Factor non-uniformity - LG - PMMA - 4cm - base 8.9 mm

Standard deviation: 0.166 Mean value: 0.243

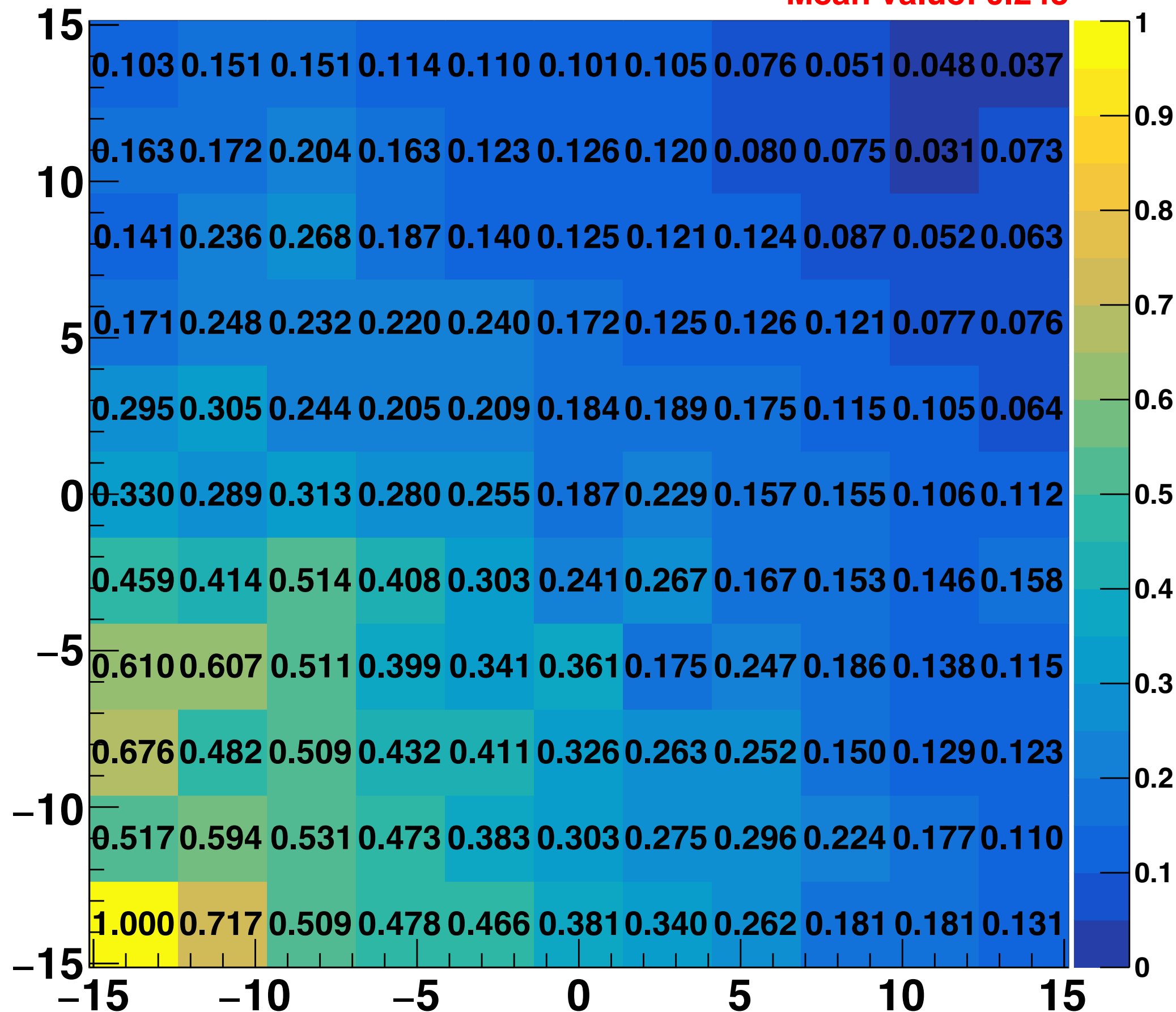

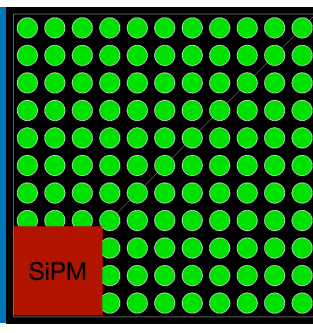

Efficiency - LG - PMMA - 5cm - base 8.9 mm

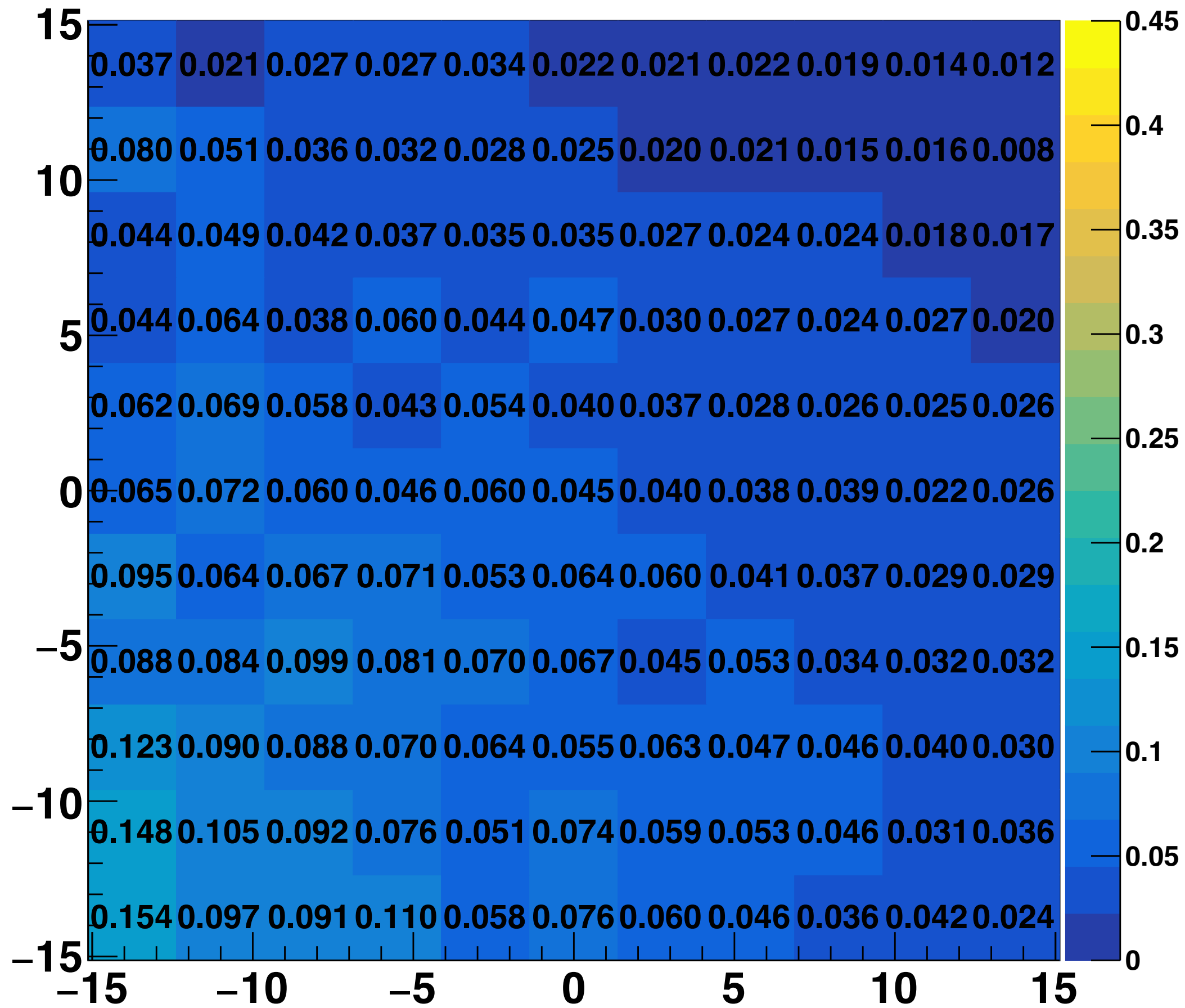

Factor non-uniformity - LG - PMMA - 5cm - base 8.9 mm

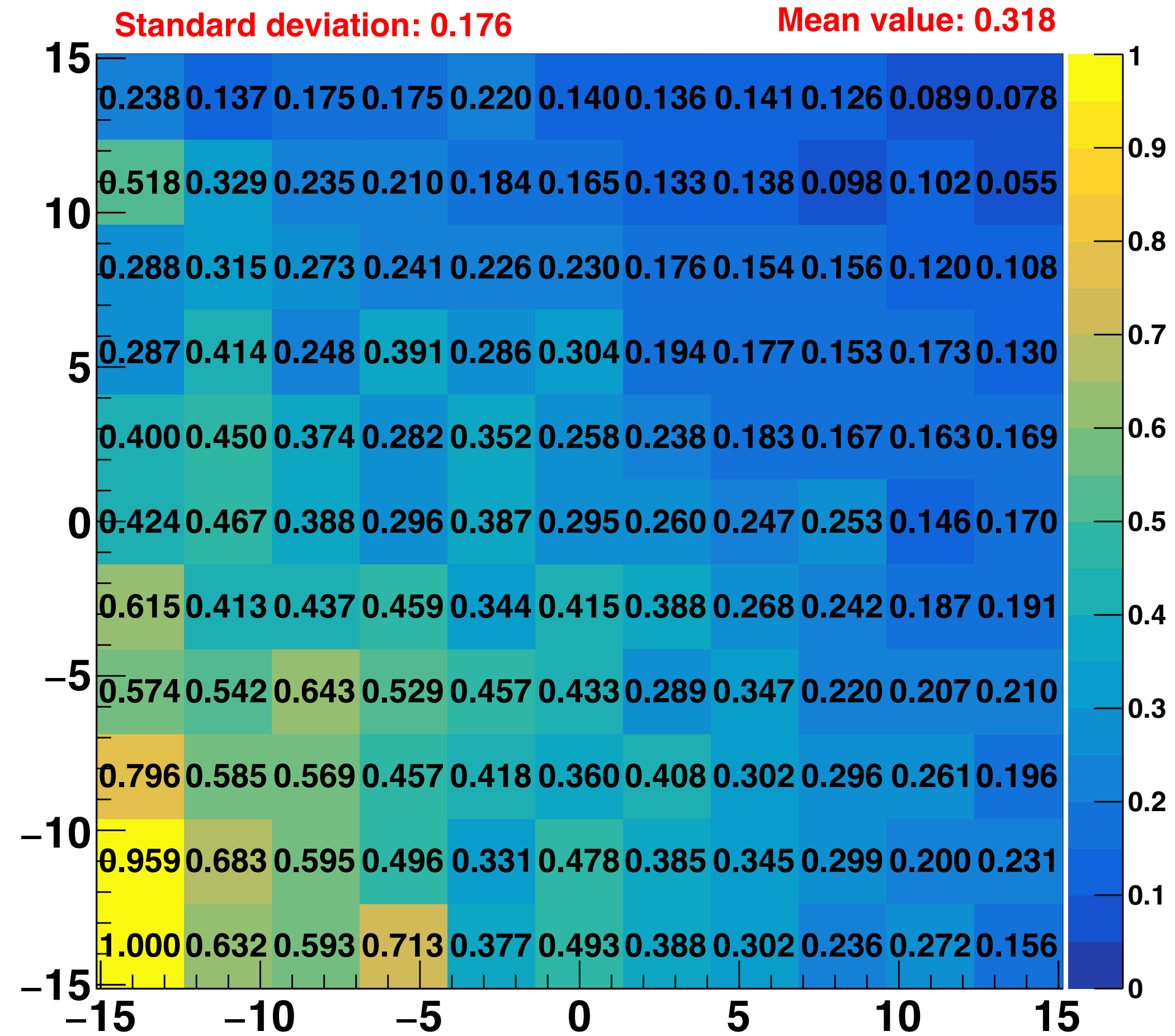

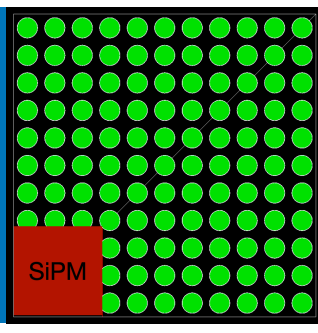

Efficiency - LG - PMMA - 6cm - base 8.9 mm

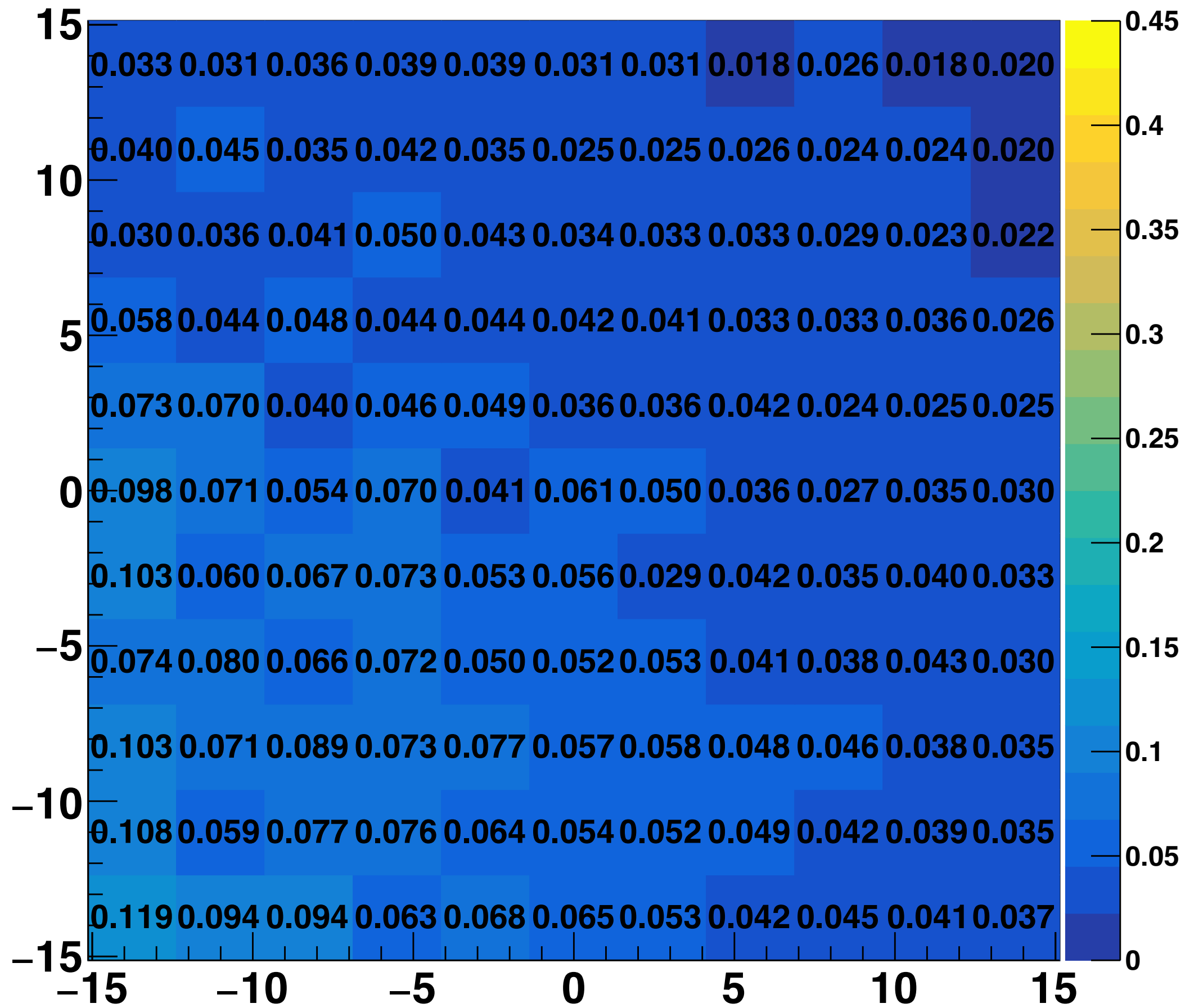

Factor non-uniformity - LG - PMMA - 6cm - base 8.9 mm

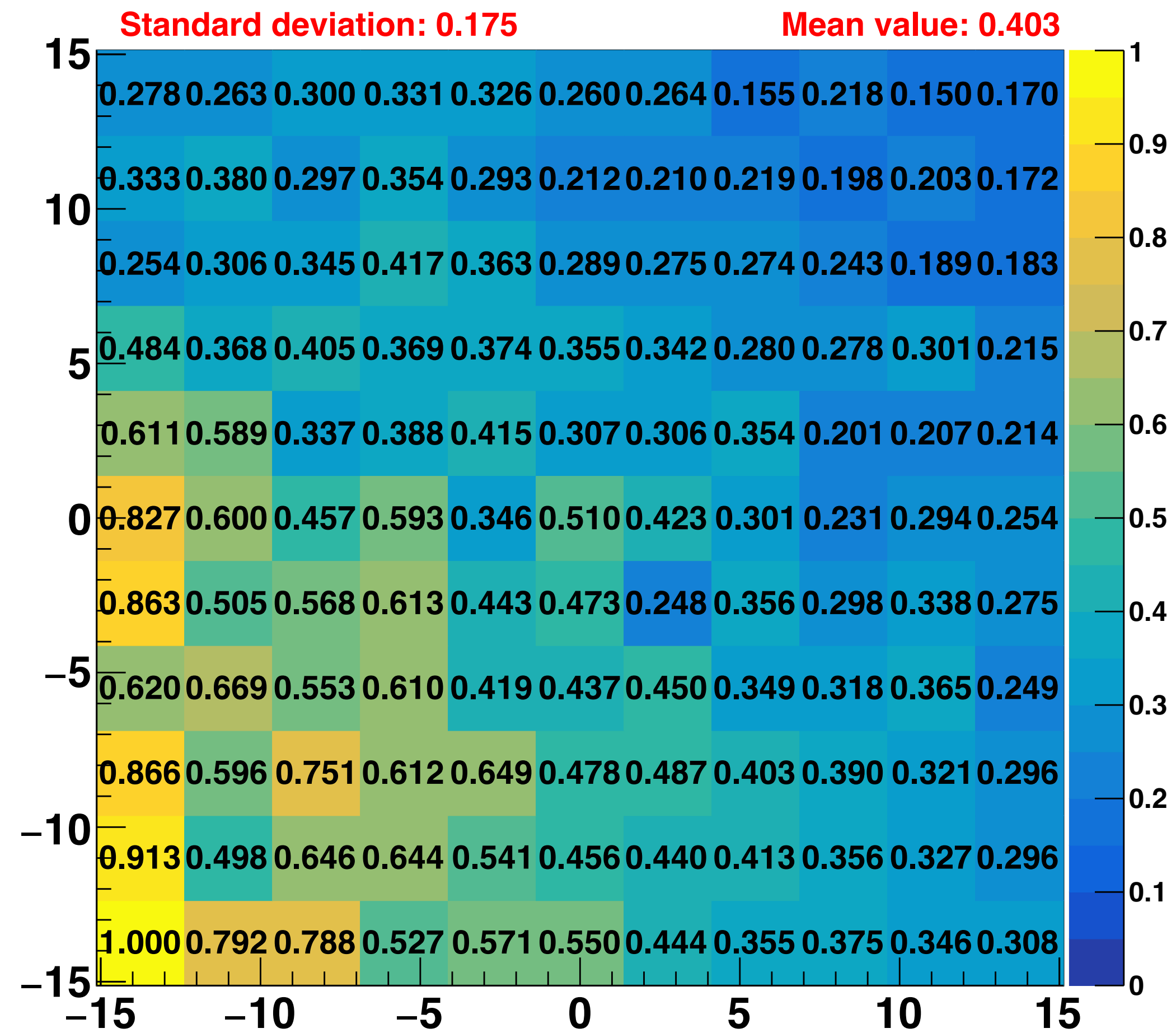

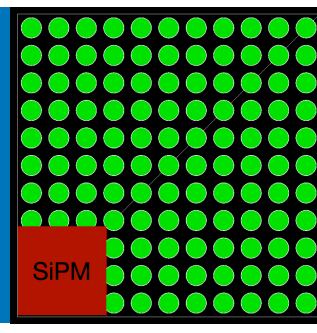

Efficiency - LG - Air - 2cm - base 8.9 mm

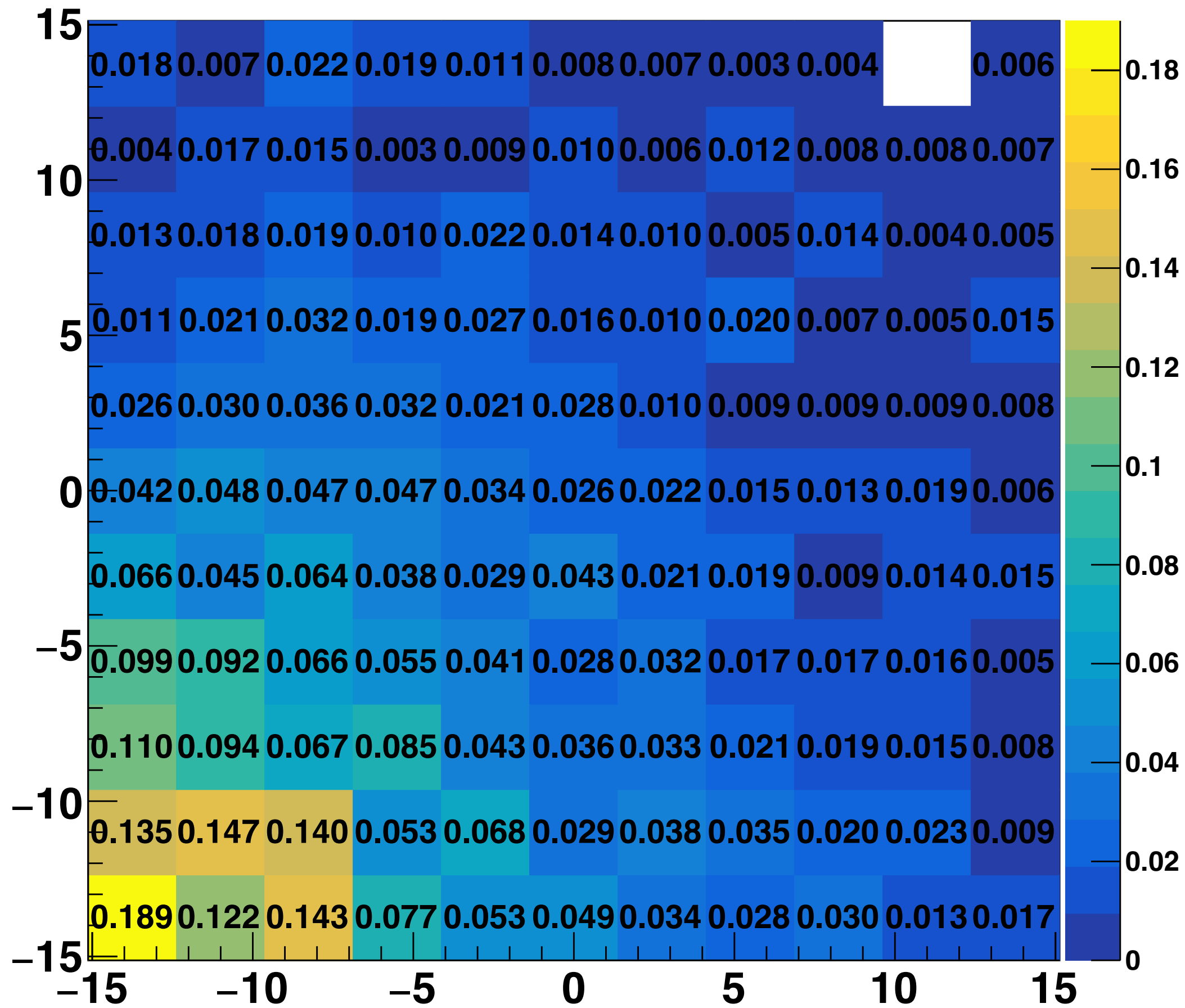

Factor non-uniformity - LG - AIR - 2cm - base 8.9 mm

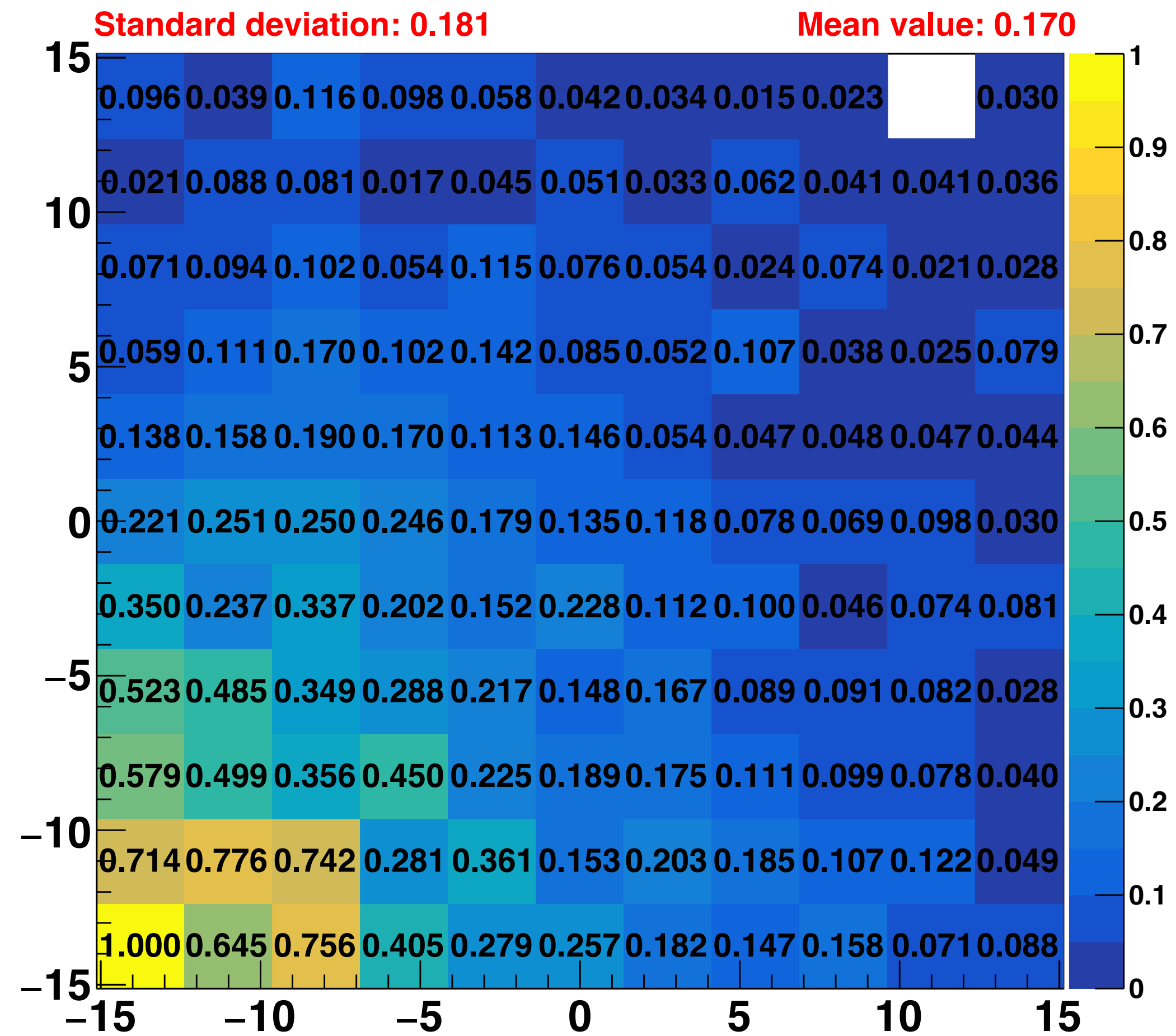

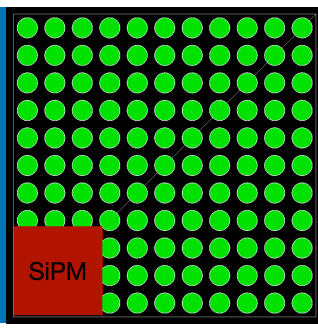

Efficiency - LG - Air - 3cm - base 8.9 mm

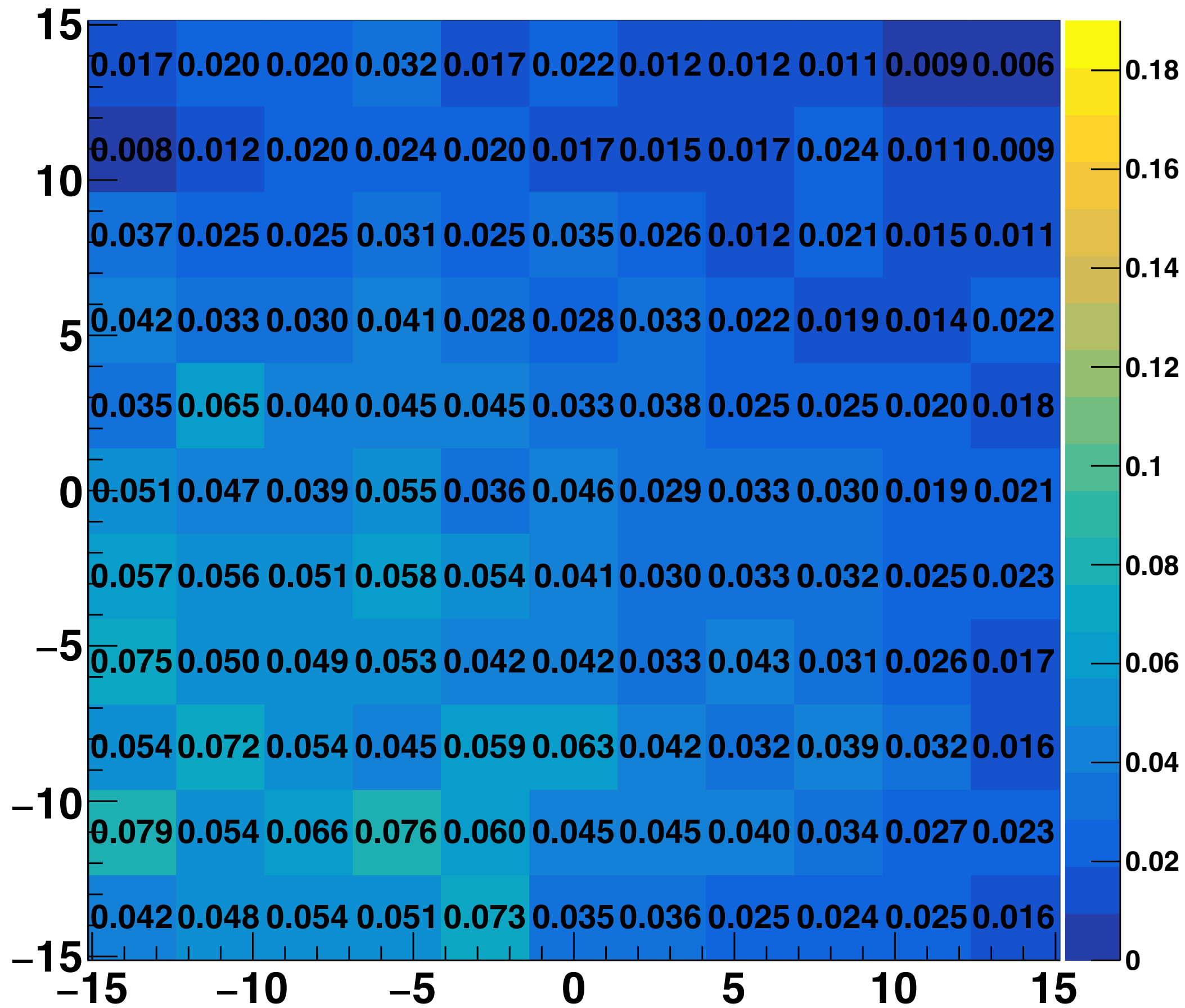

Factor non-uniformity - LG - AIR - 3cm - base 8.9 mm

Standard deviation: 0.210 Mean value: 0.432

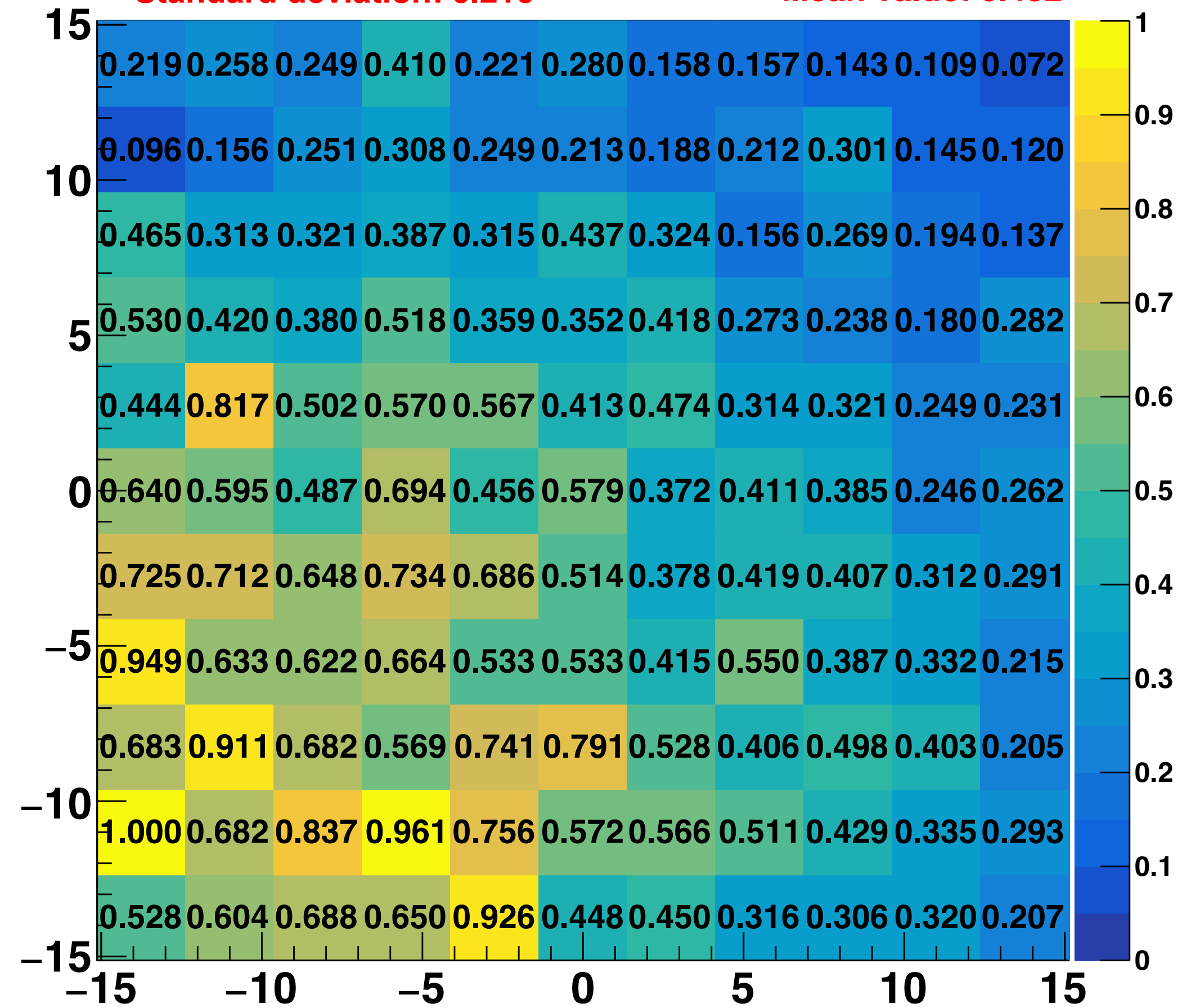

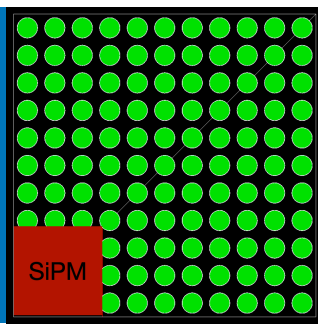

Efficiency - LG - Air - 4cm - base 8.9 mm

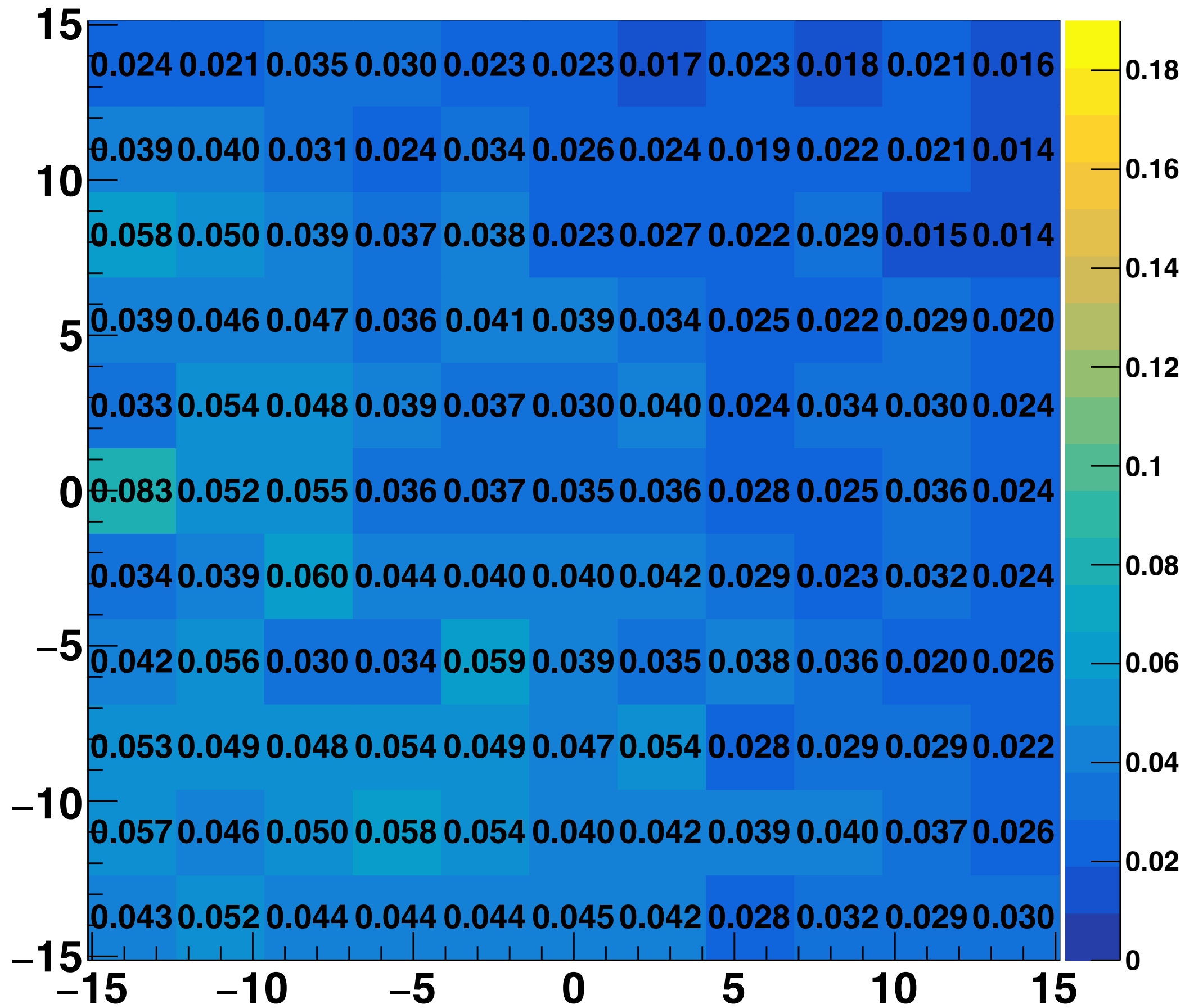

Factor non-uniformity - LG - AIR - 4cm - base 8.9 mm

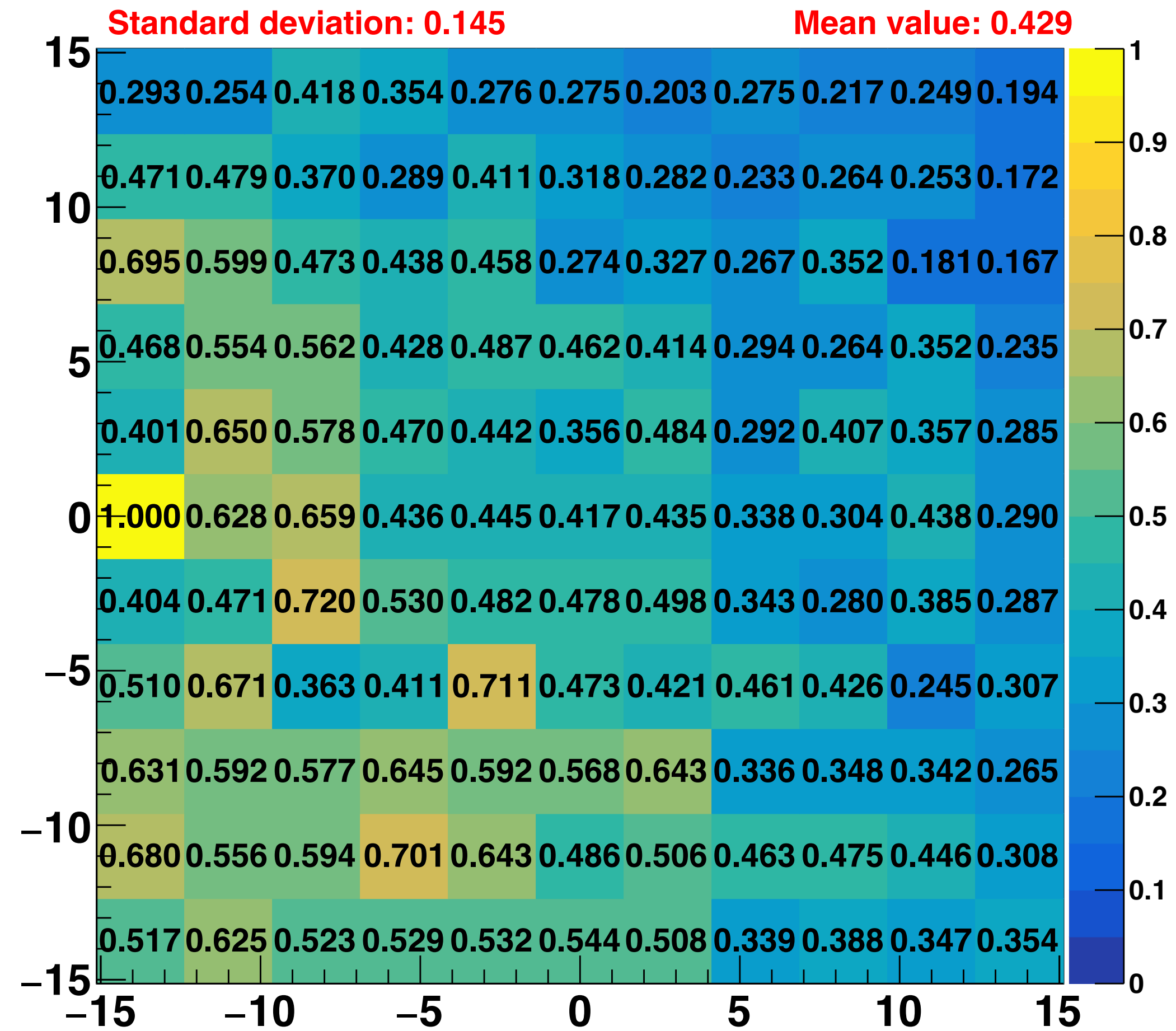

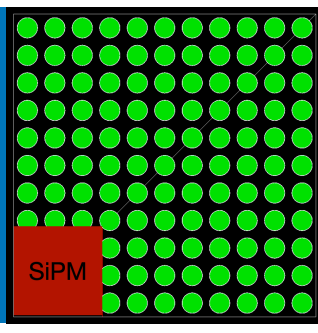

Efficiency - LG - Air - 5cm - base 8.9 mm

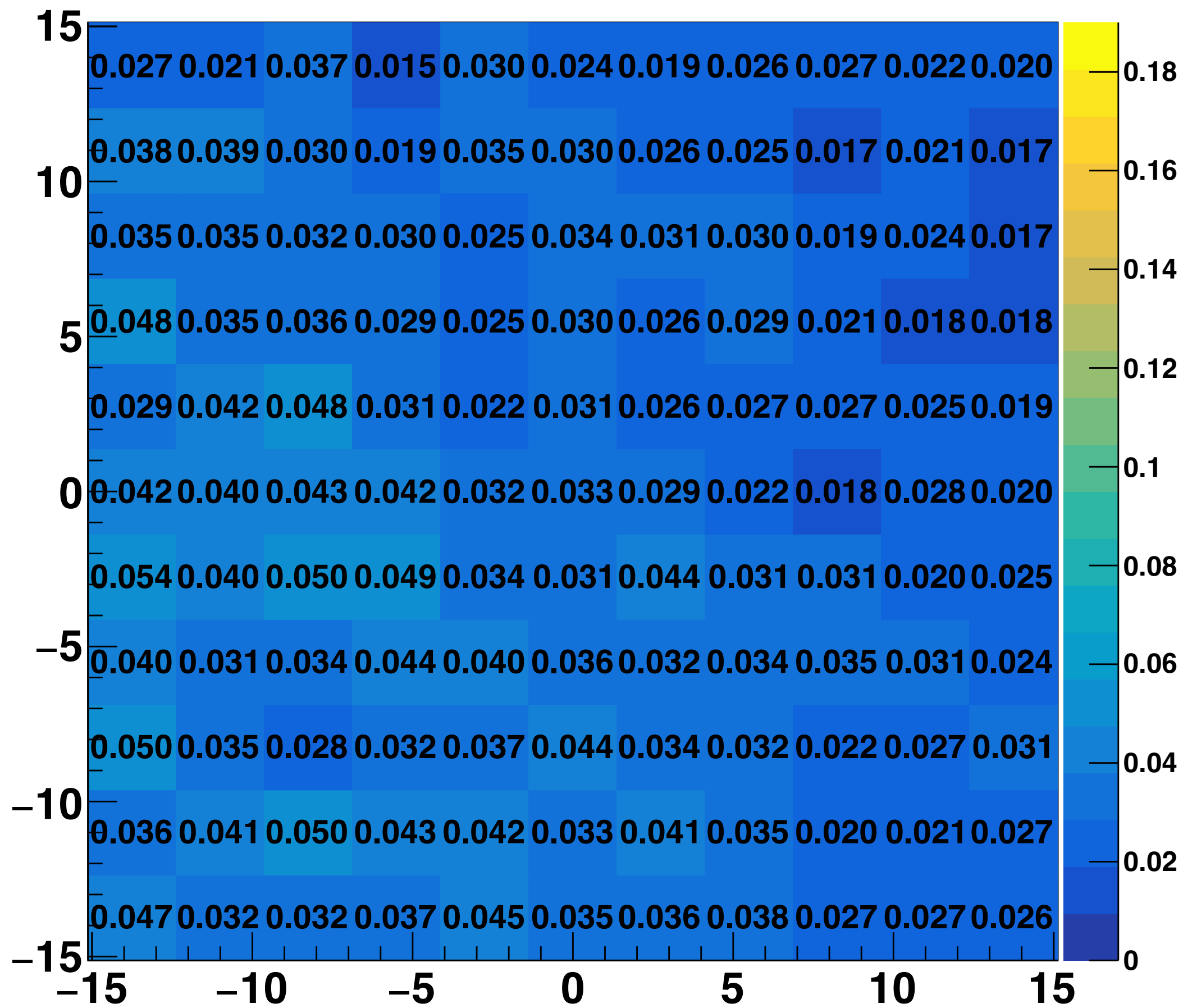

Factor non-uniformity - LG - AIR - 5cm - base 8.9 mm

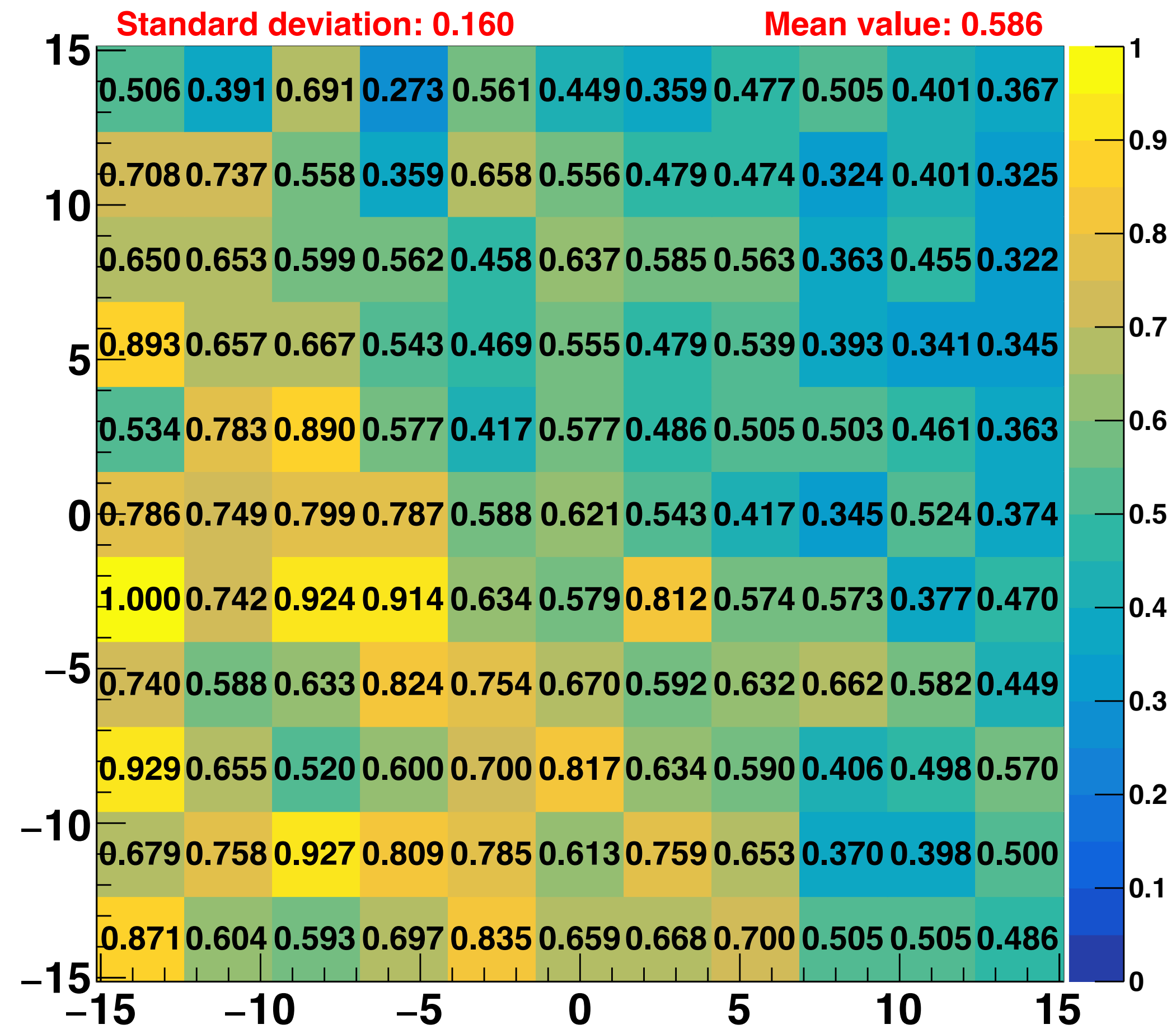

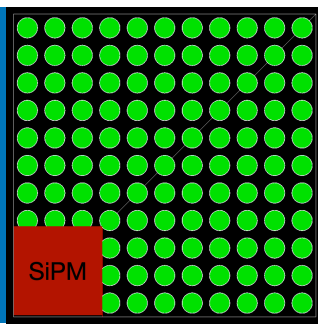

Efficiency - LG - Air - 6cm - base 8.9 mm

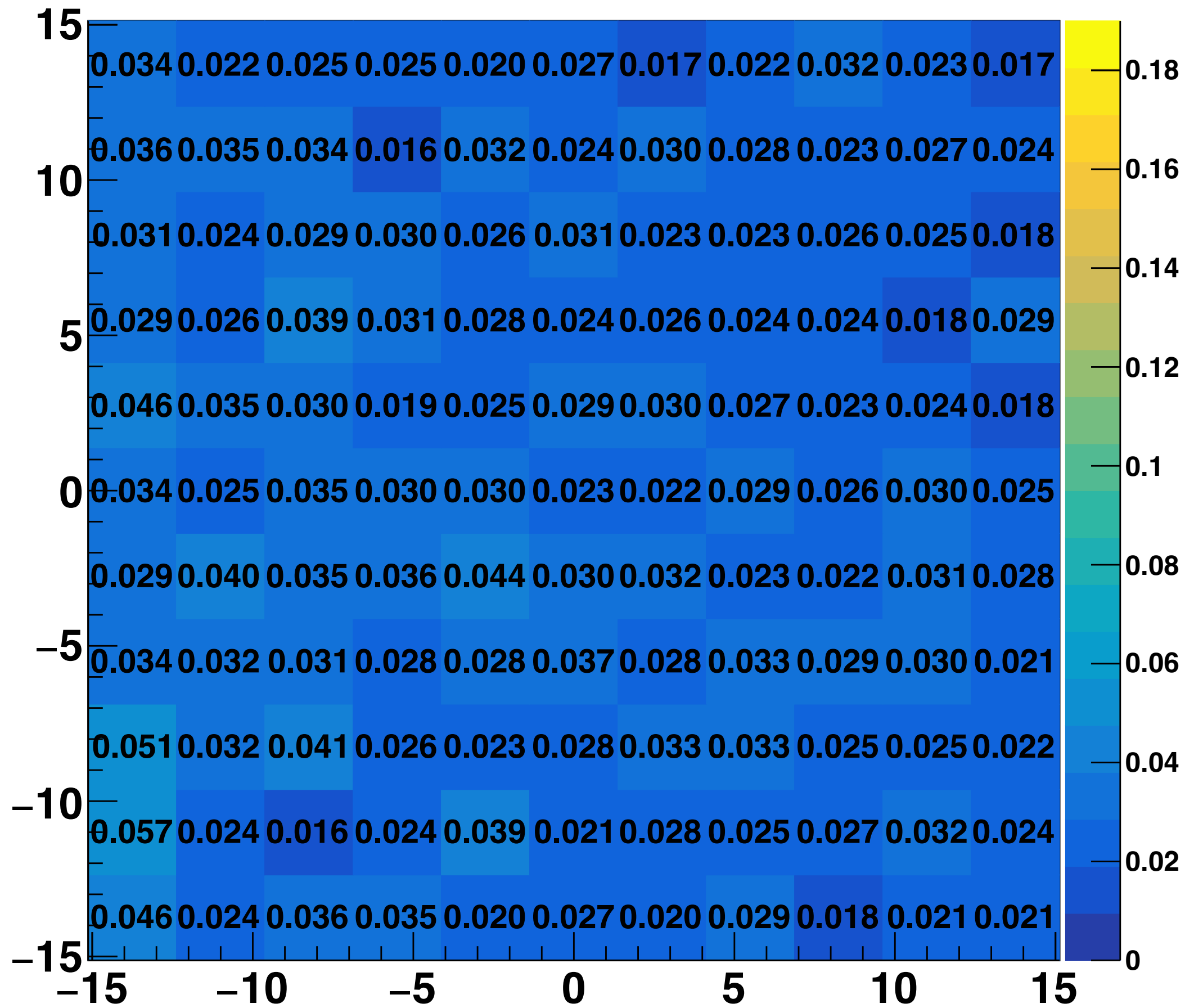

Factor non-uniformity - LG - AIR - 6cm - base 8.9 mm

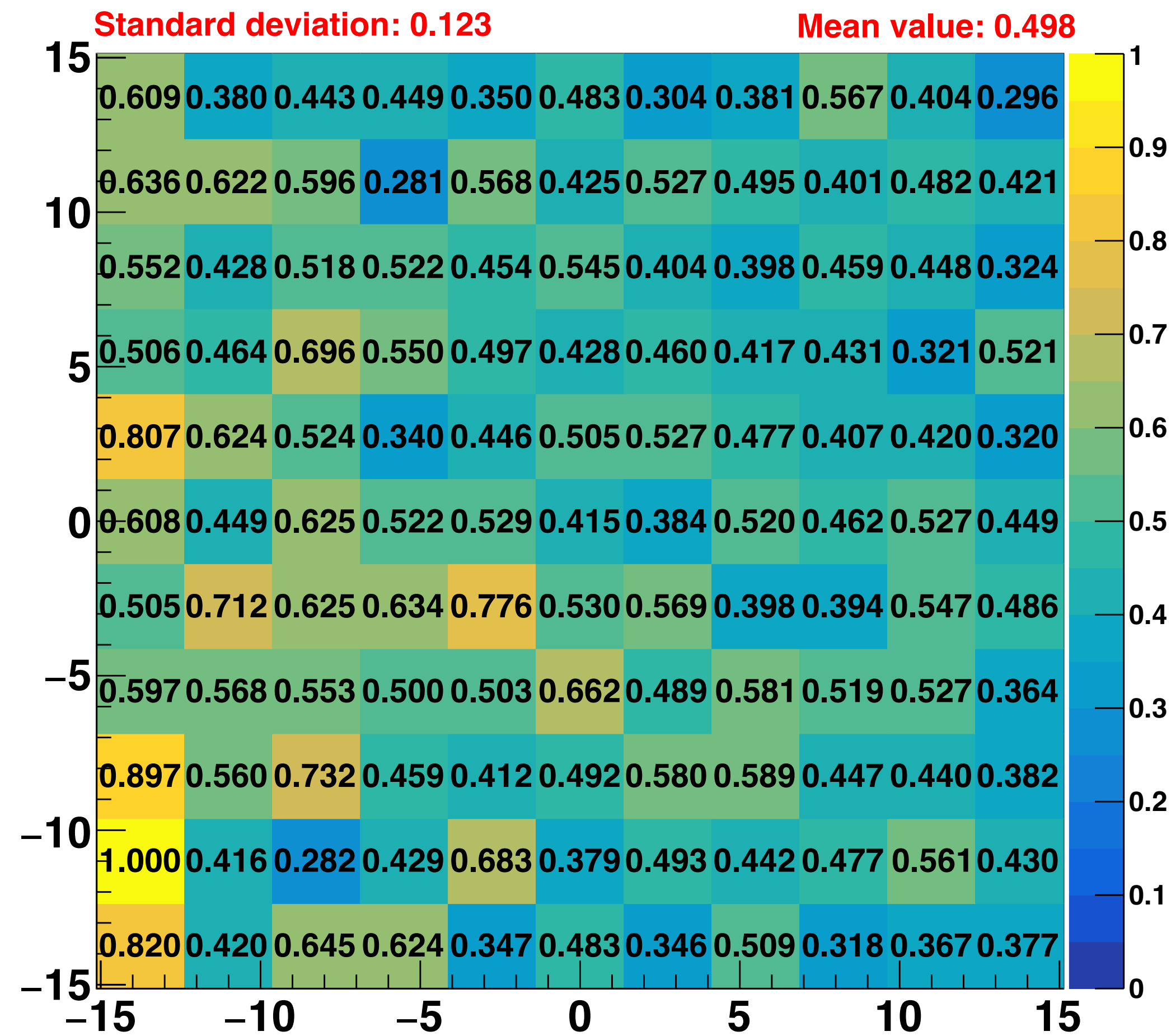

Geometry 3 -- PMMA - 8.9mm GI

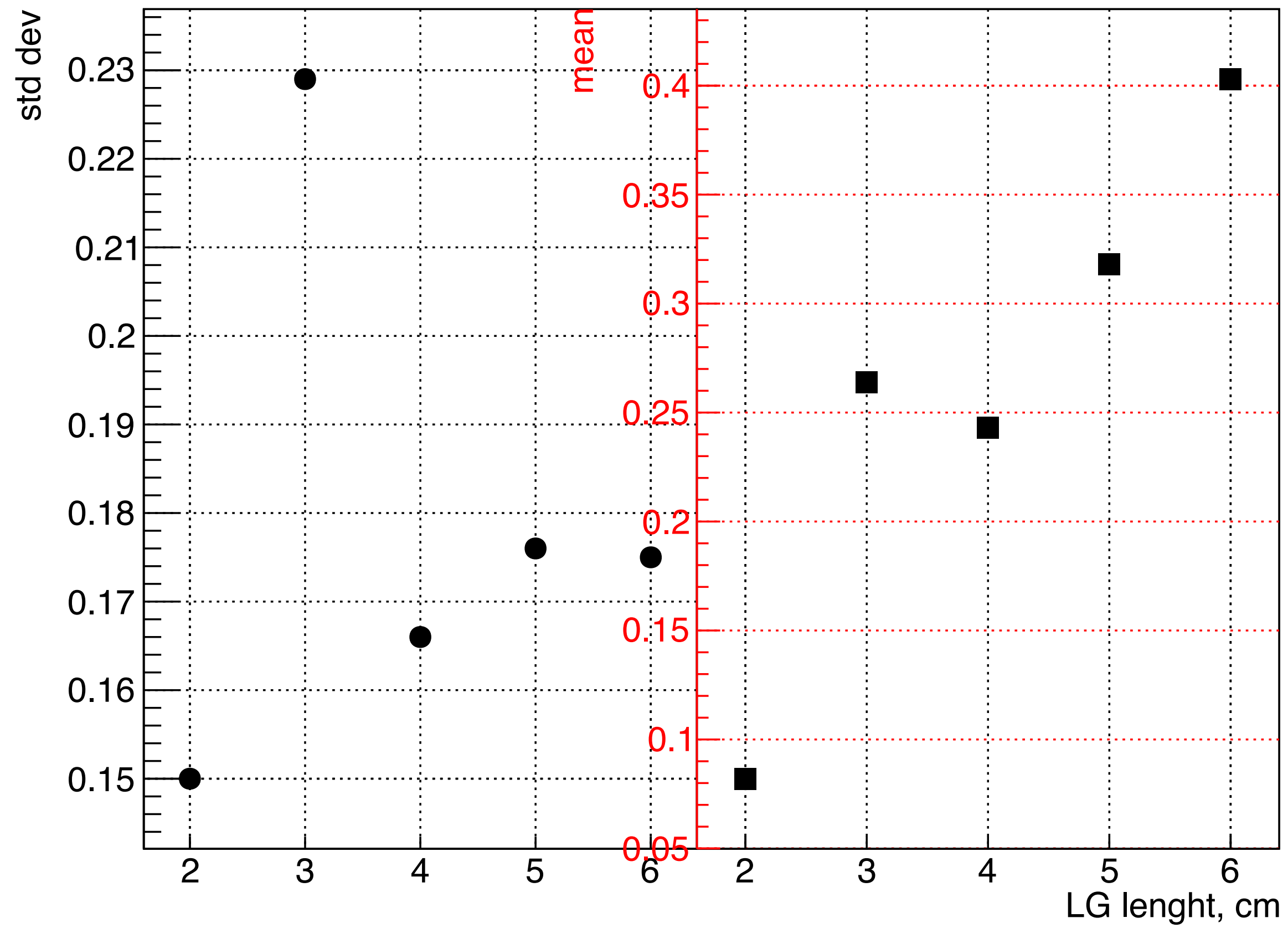

Geometry 3 -- AIR - 8.9mm Graph

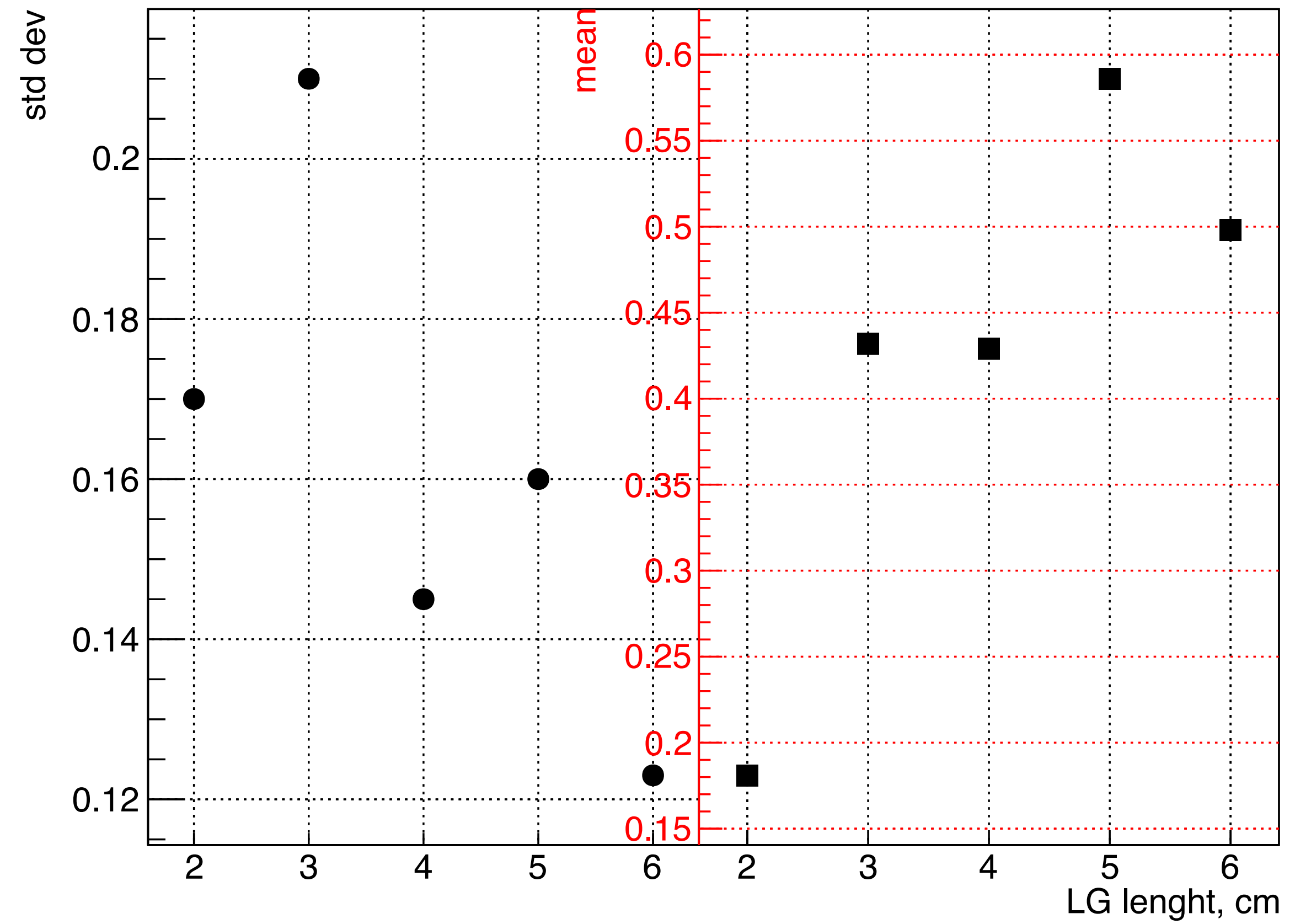

- **Geometry 4.1**

PMMA

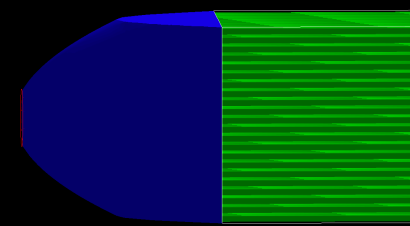

statistic 11.000 - muon 1 GeV

Winstone cone
PMT 4.5

• Geometry 4

PMMA

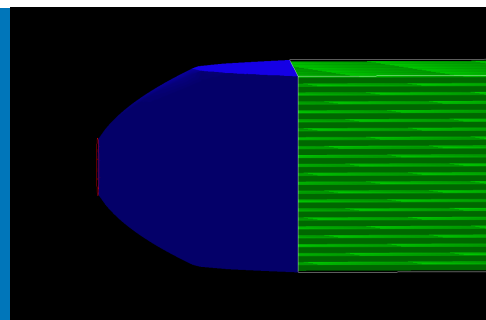

statistic 11.000 - muon 1 GeV

Winstone cone
PMT 4.5

Efficiency - LG - PMMA - 2cm - base round - 4.5 mm

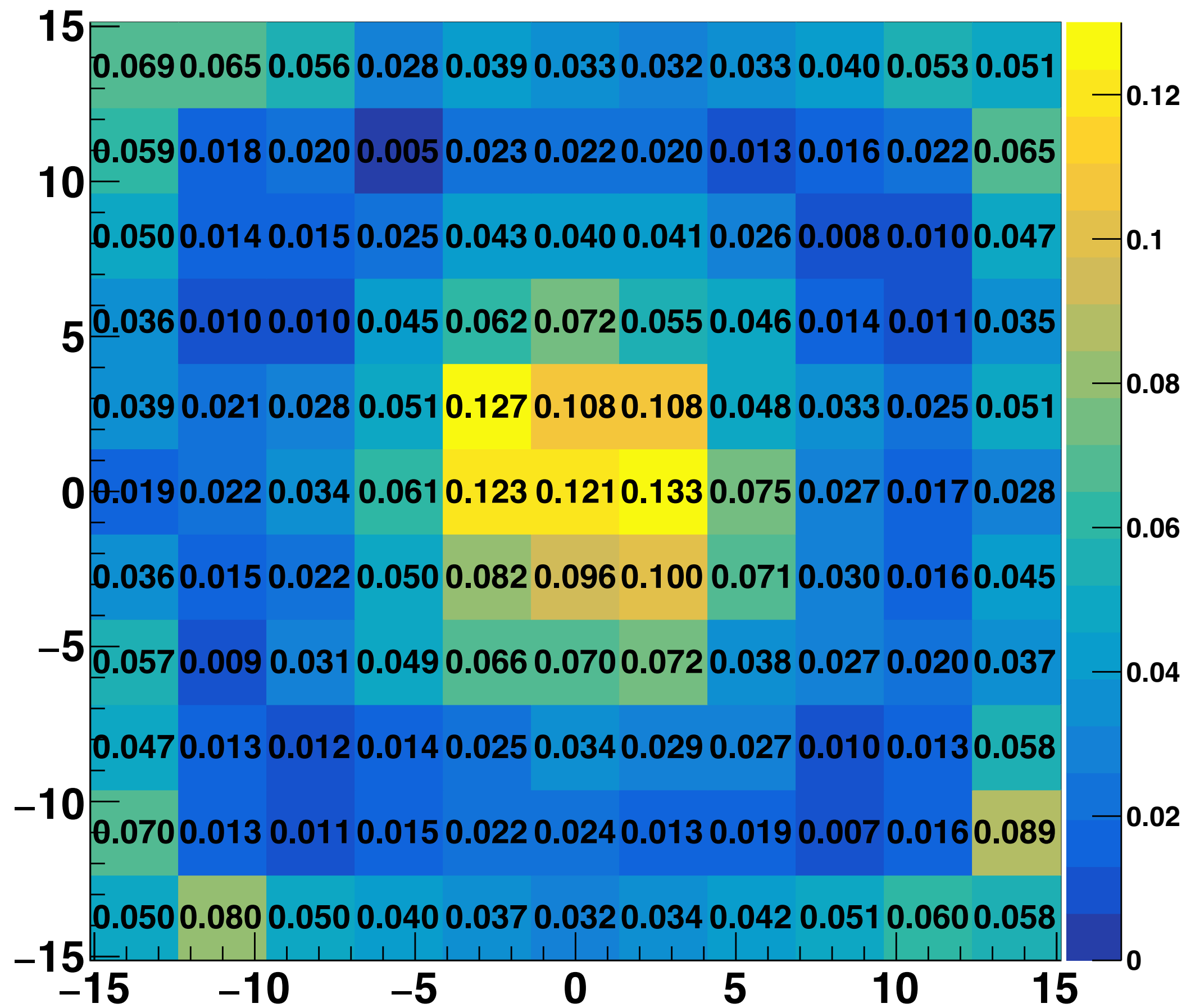

Factor non-uniformity - LG - PMMA - 2cm - base round - 4.5 mm

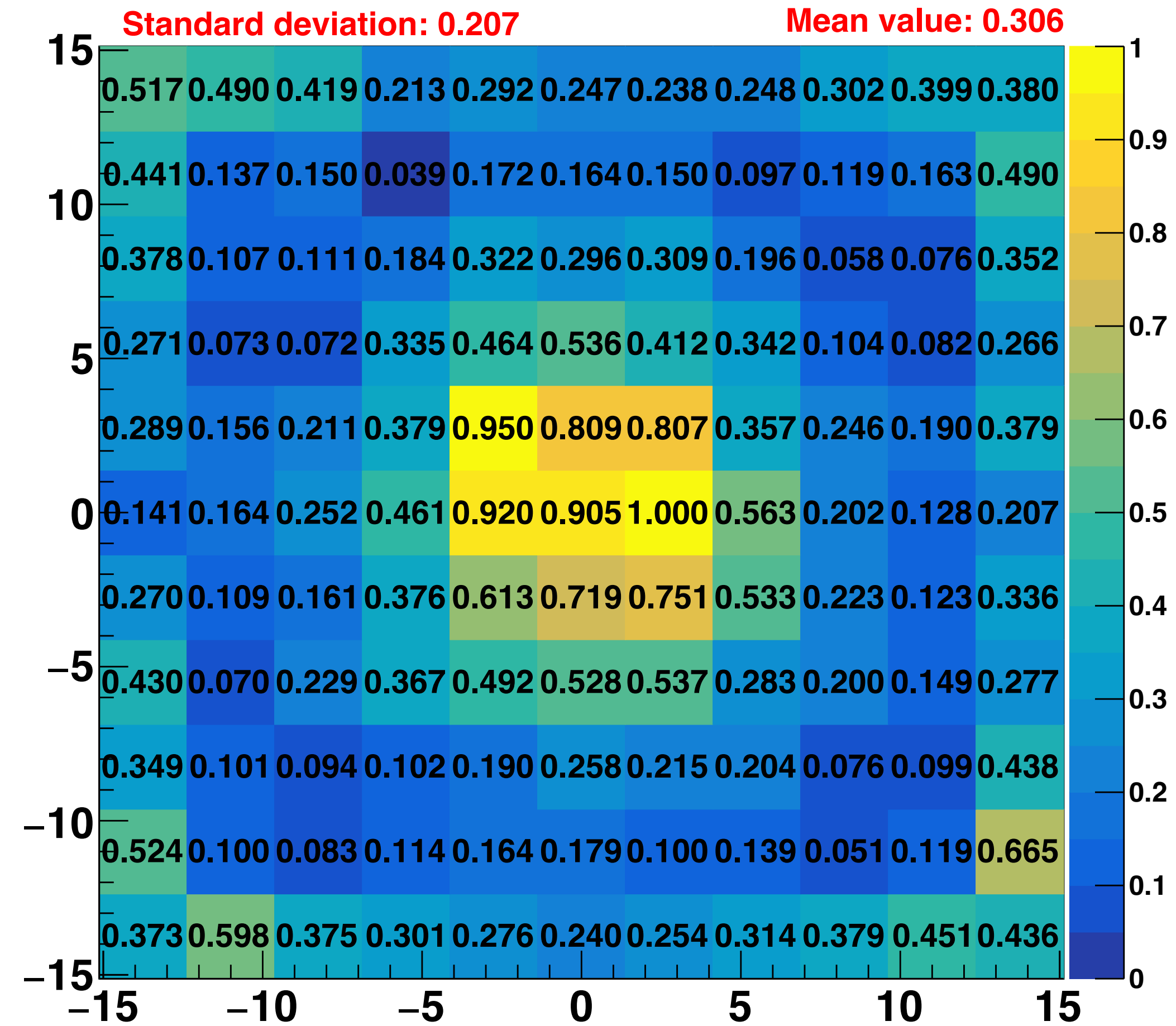

Geometry 4

PMMA

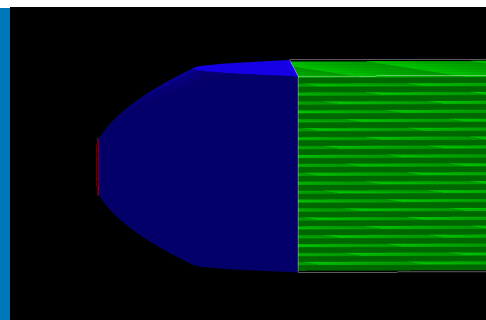

statistic 11.000 - muon 1 GeV

Winstone cone
PMT 4.5

Efficiency - LG - PMMA - 3cm - base round - 4.5 mm

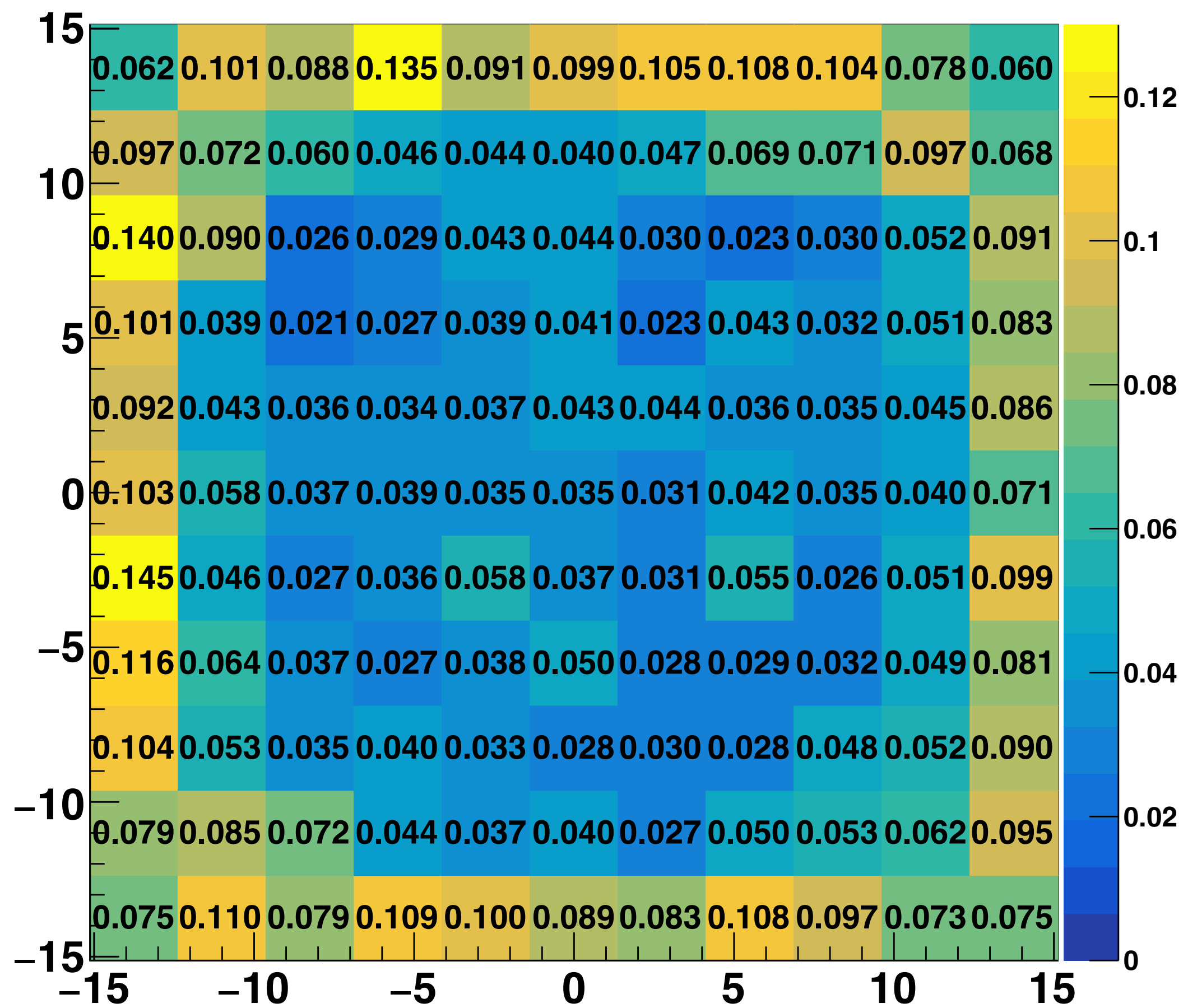

Factor non-uniformity - LG - PMMA - 3cm - base round - 4.5 mm

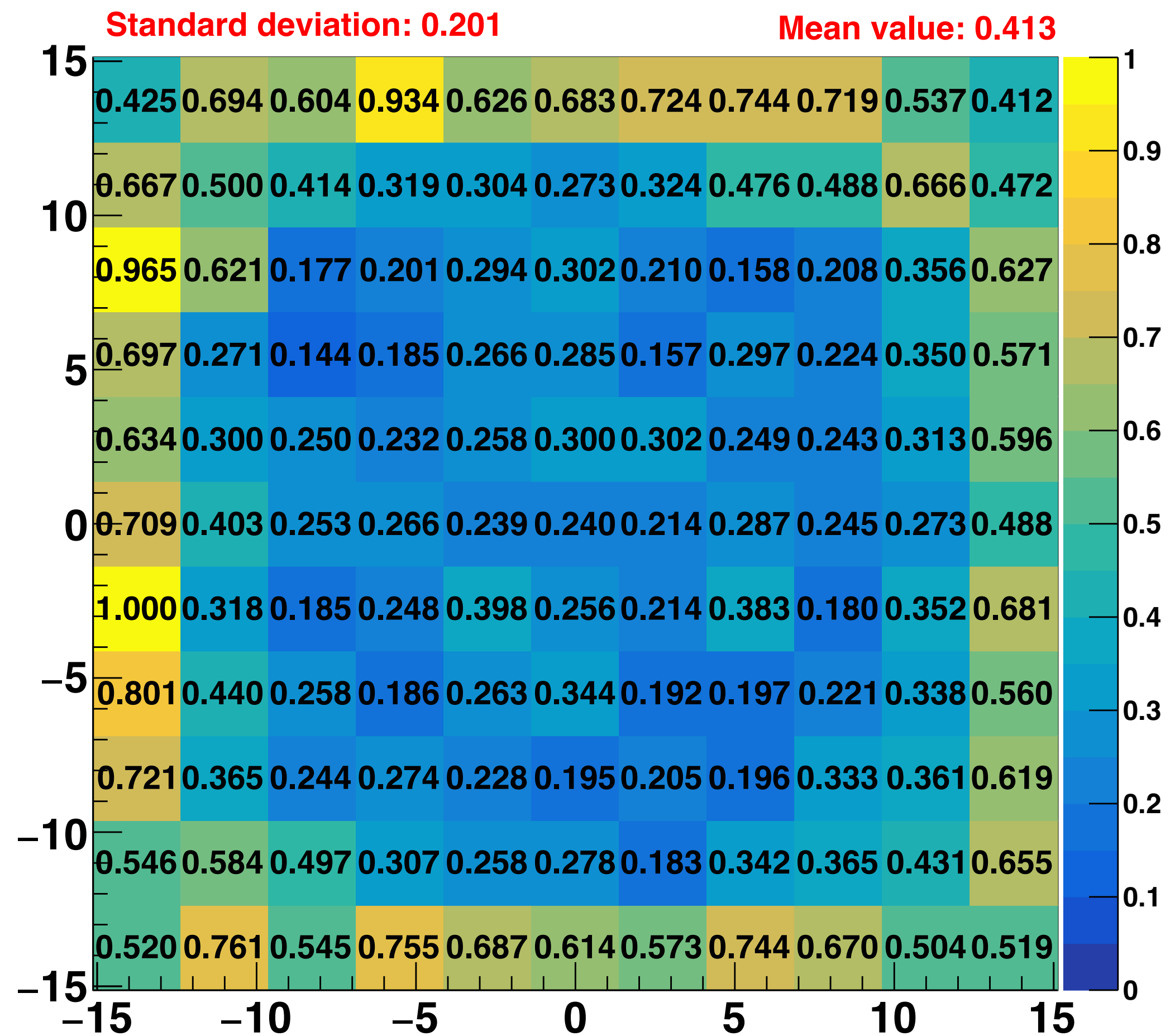

Geometry 4

PMMA

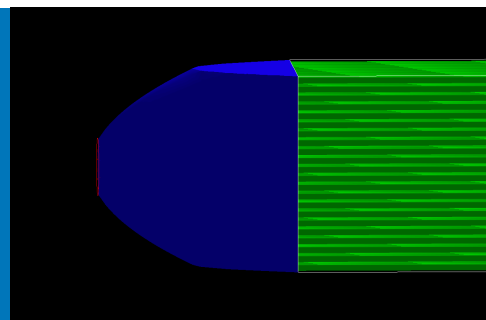

statistic 11.000 - muon 1 GeV

Winstone cone
PMT 4.5

Efficiency - LG - PMMA - 4cm - base round - 4.5 mm

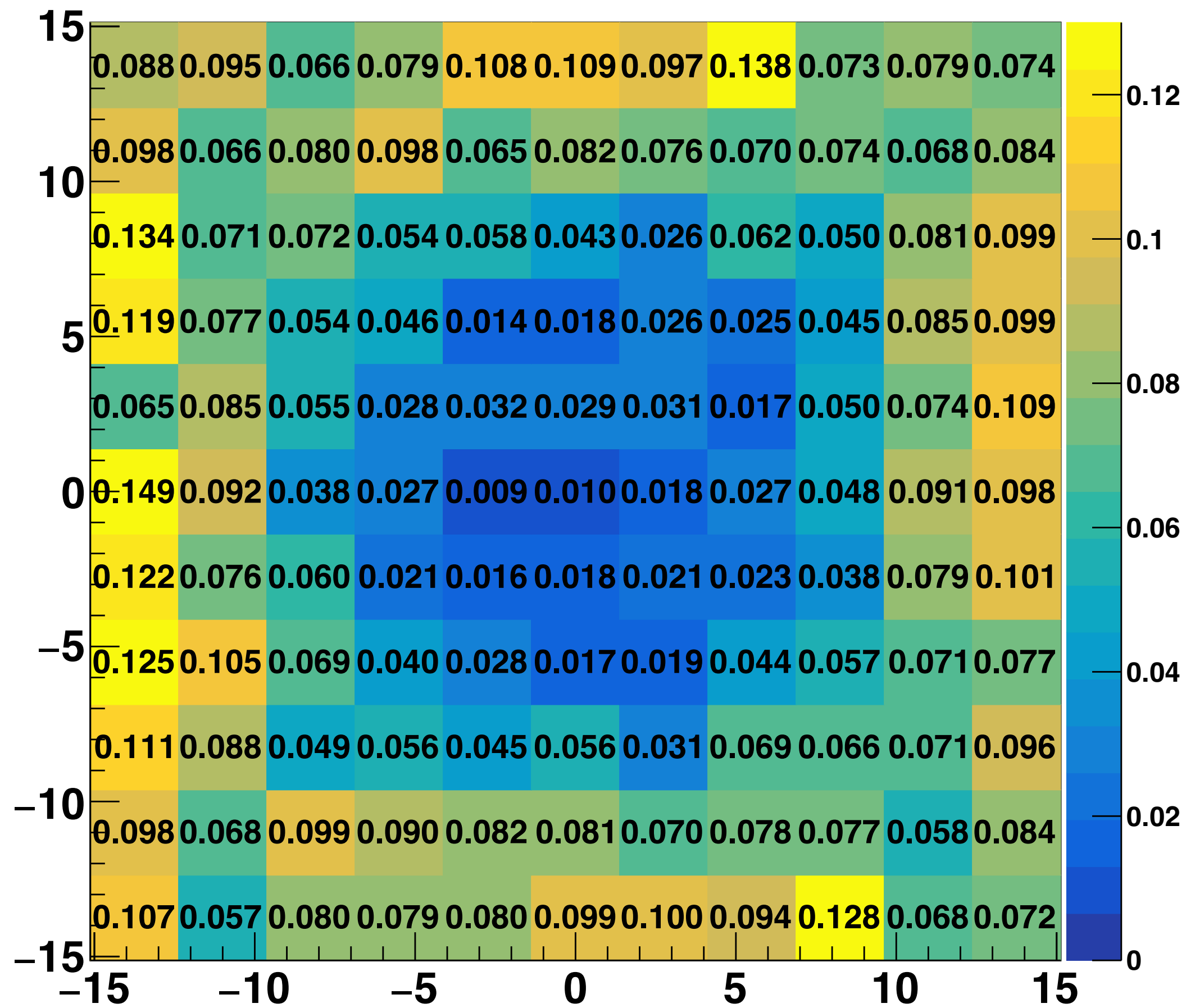

Factor non-uniformity - LG - PMMA - 4cm - base round - 4.5 mm

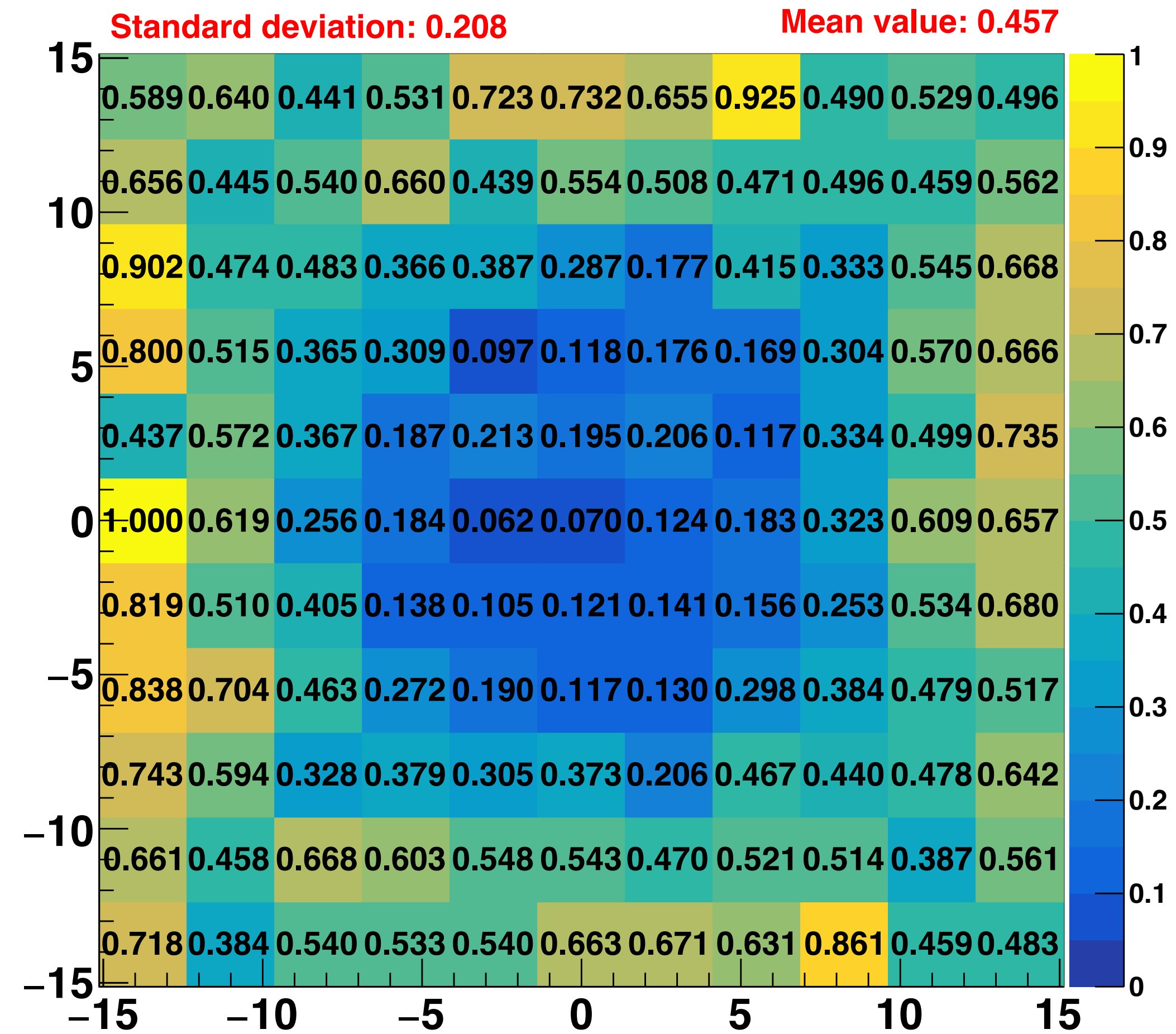

• Geometry 4

PMMA

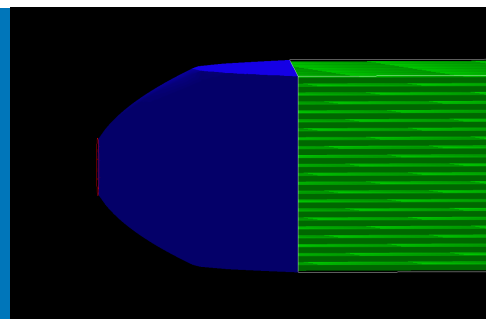

statistic 11.000 - muon 1 GeV

Winstone cone
PMT 4.5

Efficiency - LG - PMMA - 5cm - base round - 4.5 mm

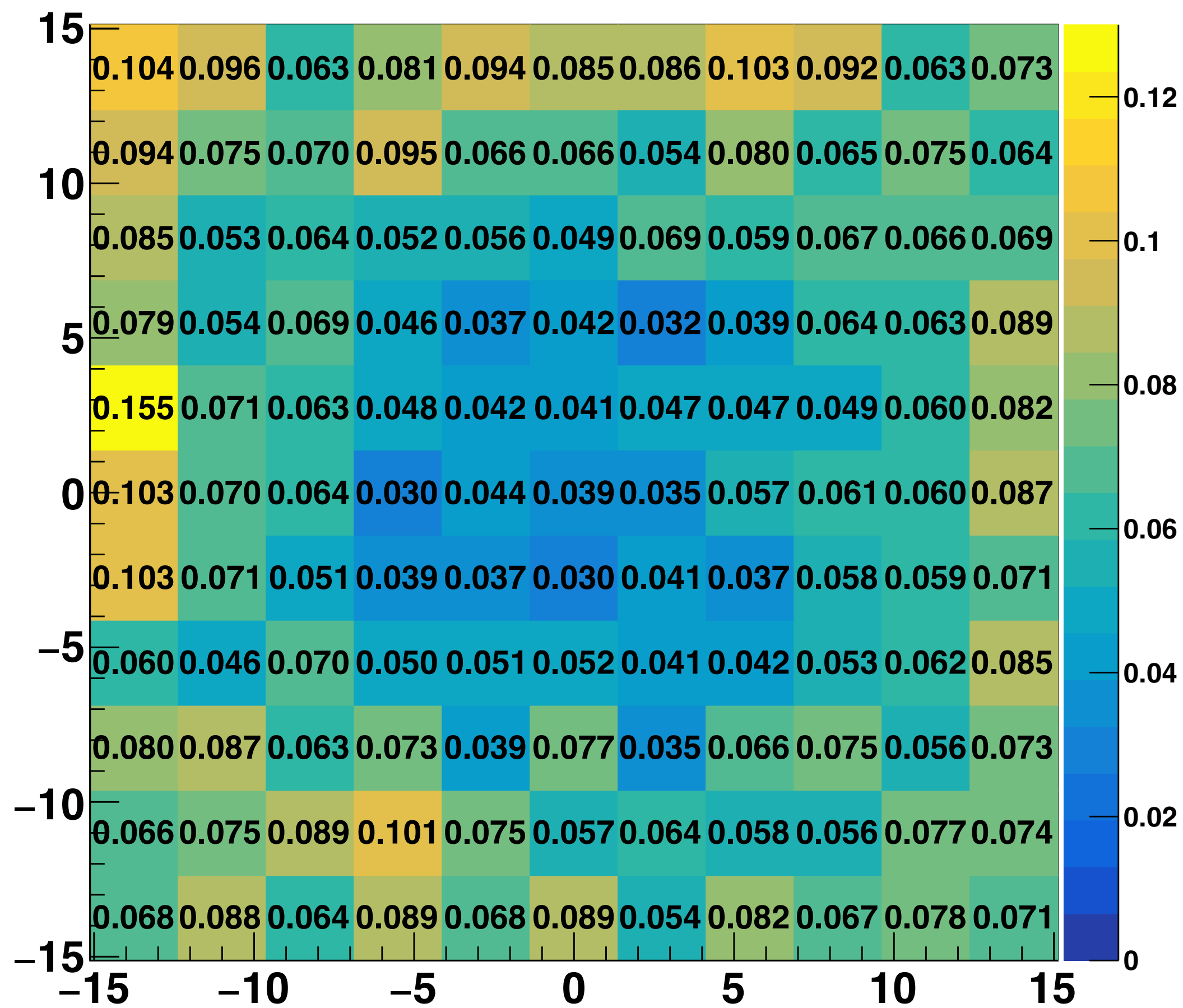

Factor non-uniformity - LG - PMMA - 5cm - base round - 4.5 mm

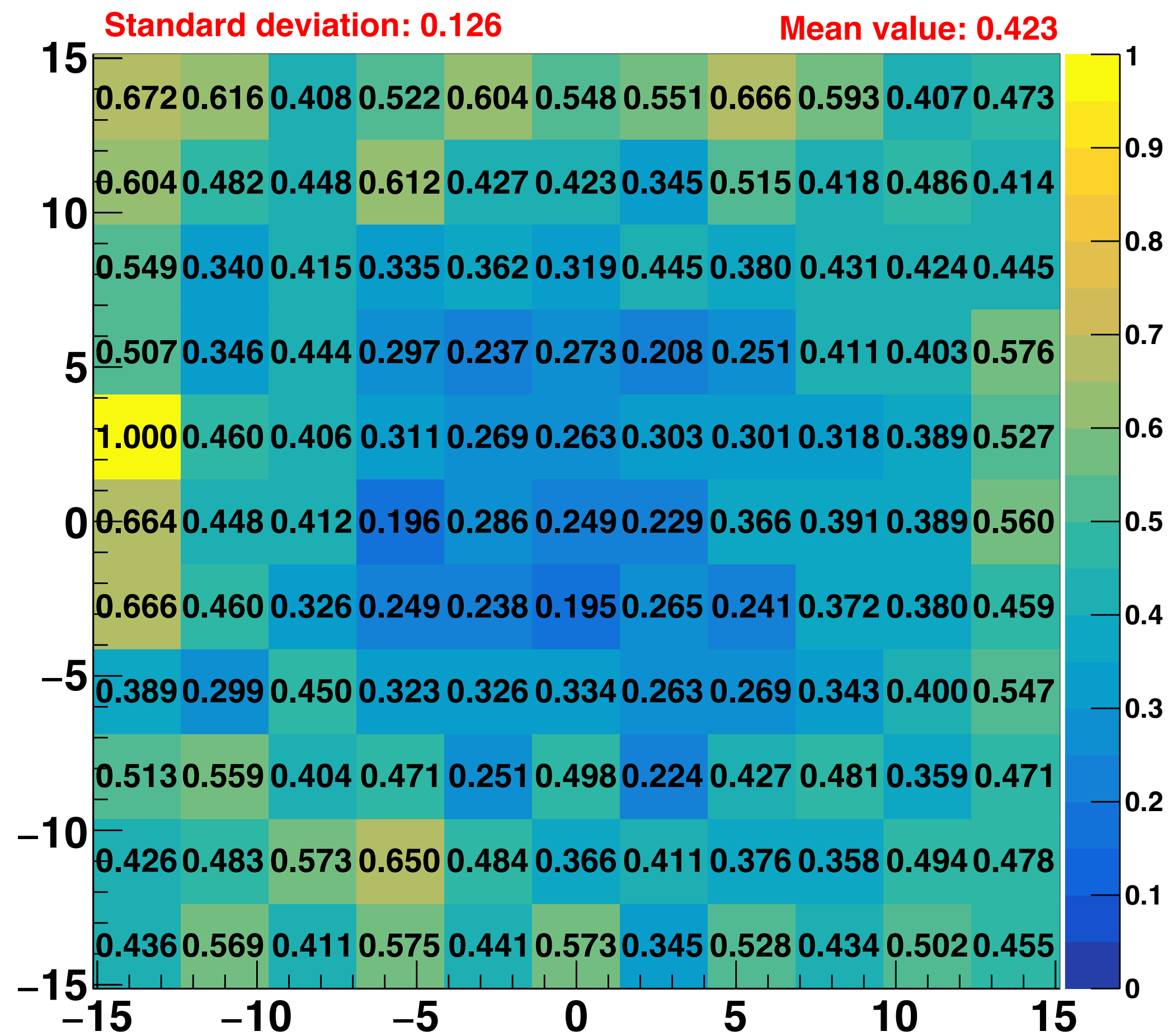

Geometry 4

PMMA

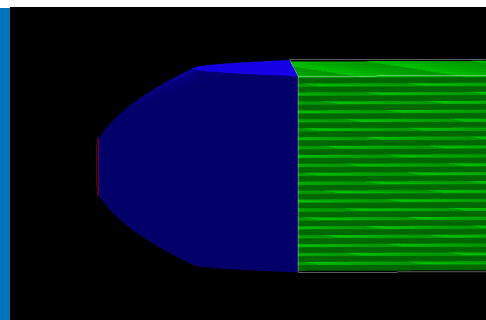

statistic 11.000 - muon 1 GeV

Winstone cone
PMT 4.5

Efficiency - LG - PMMA - 6cm - base round - 4.5 mm

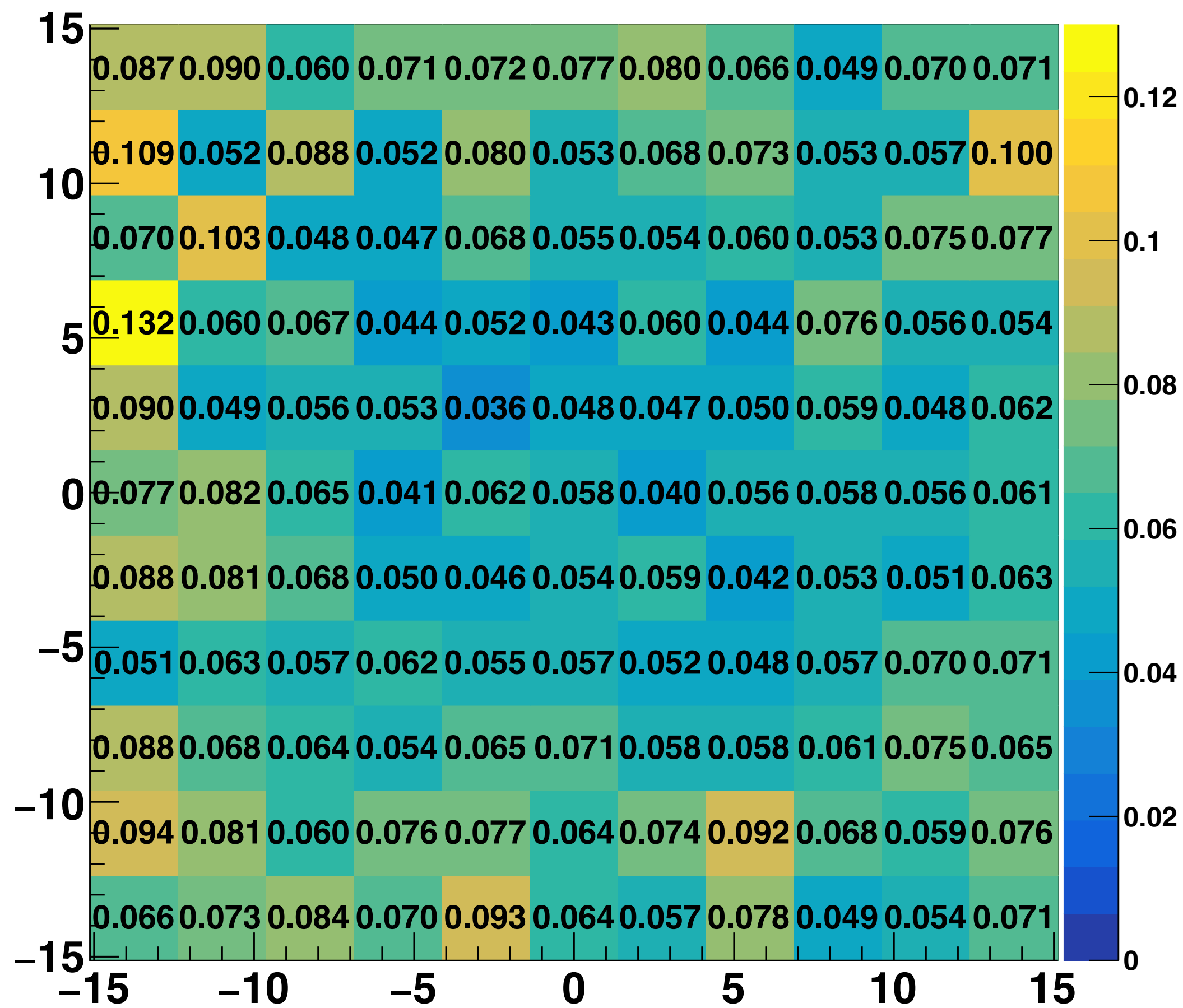

Factor non-uniformity - LG - PMMA - 6cm - base round - 4.5 mm

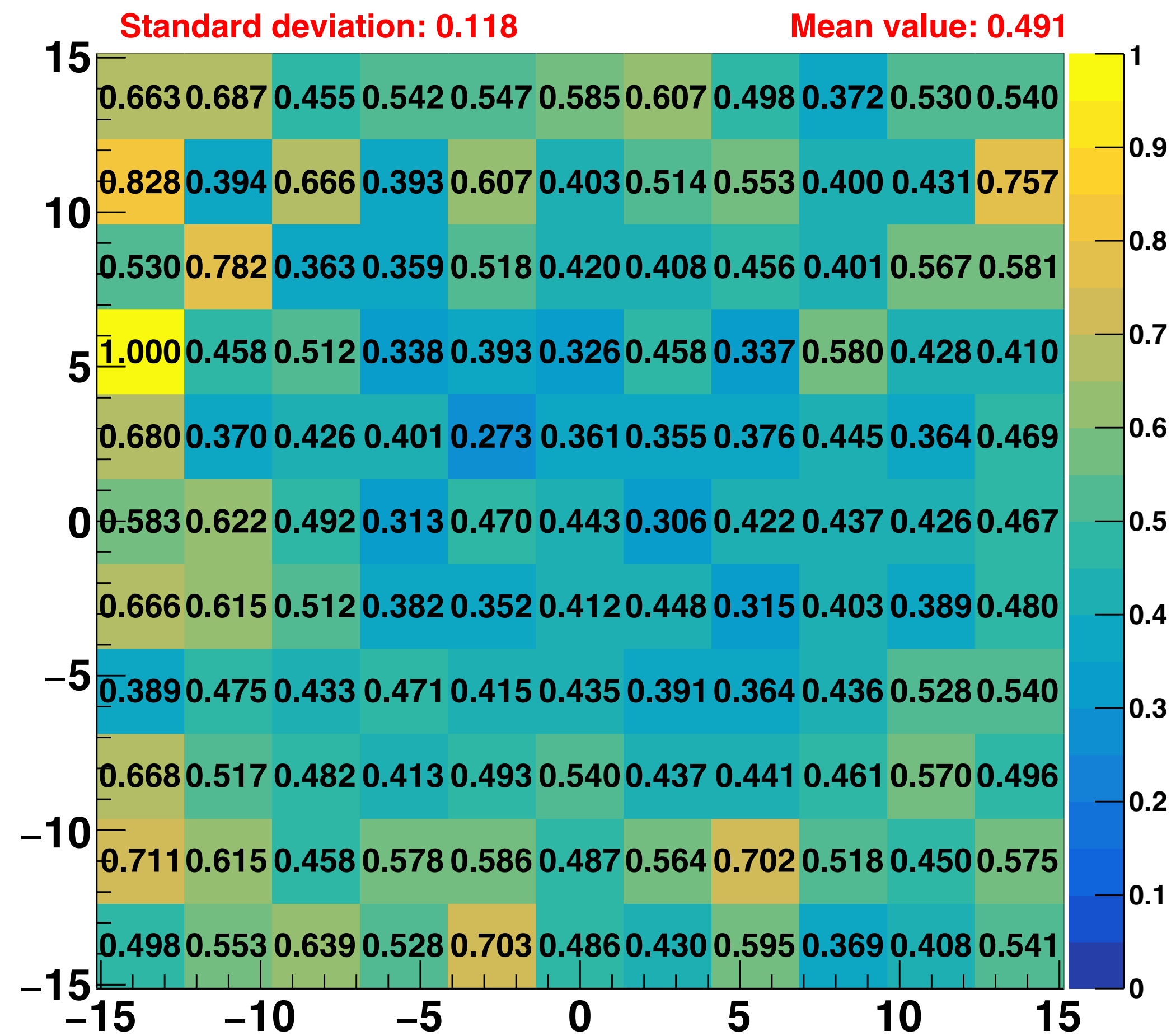

Geometry 4

AIR

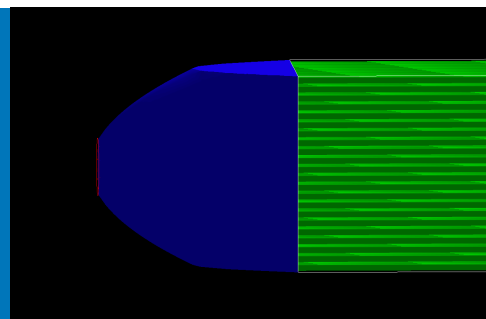

statistic 11.000 - muon 1 GeV

Winstone cone
PMT 4.5

Efficiency - LG - Air - 2cm - base round - 4.5 mm

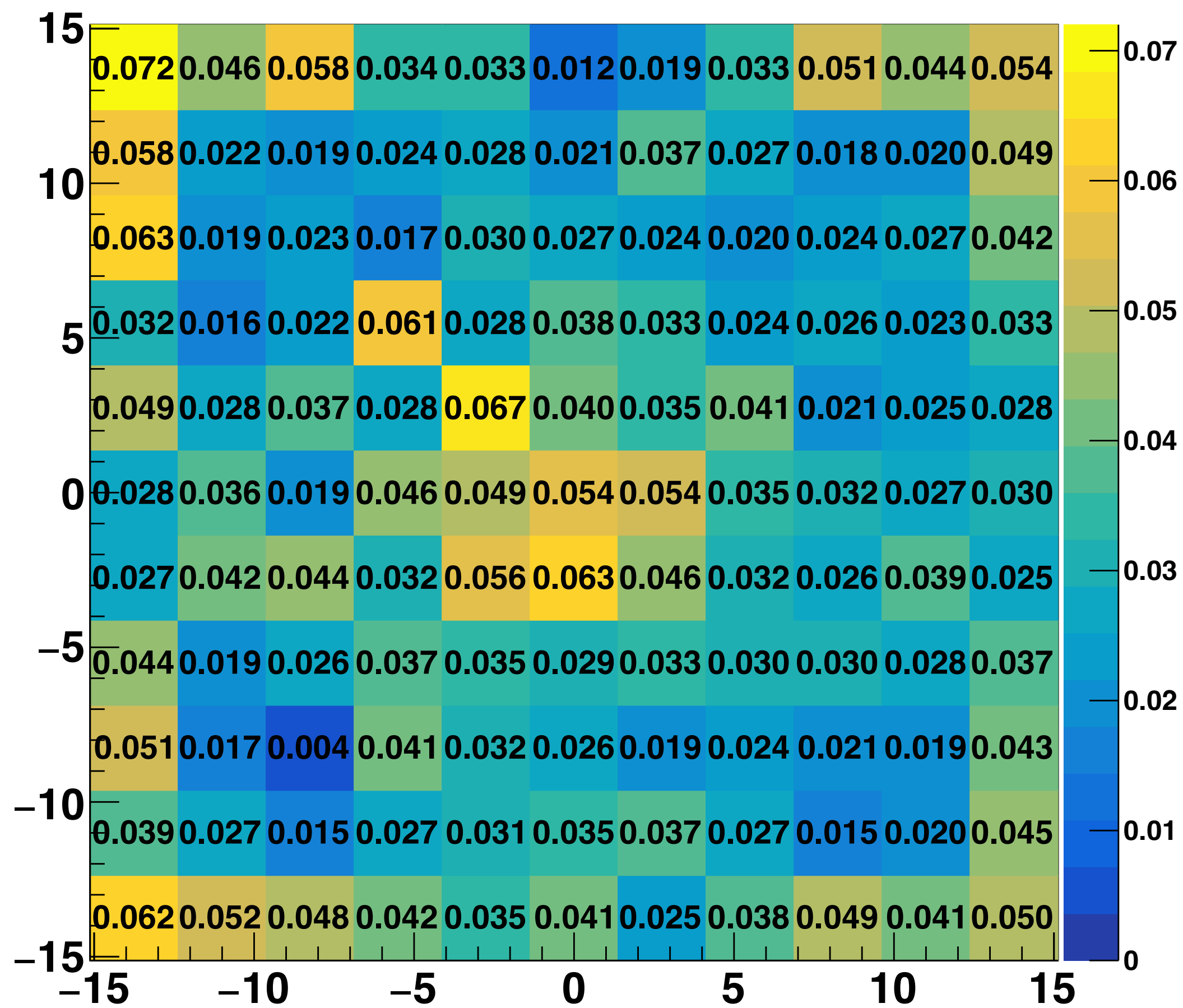

Factor non-uniformity - LG - Air - 2cm - base round - 4.5 mm

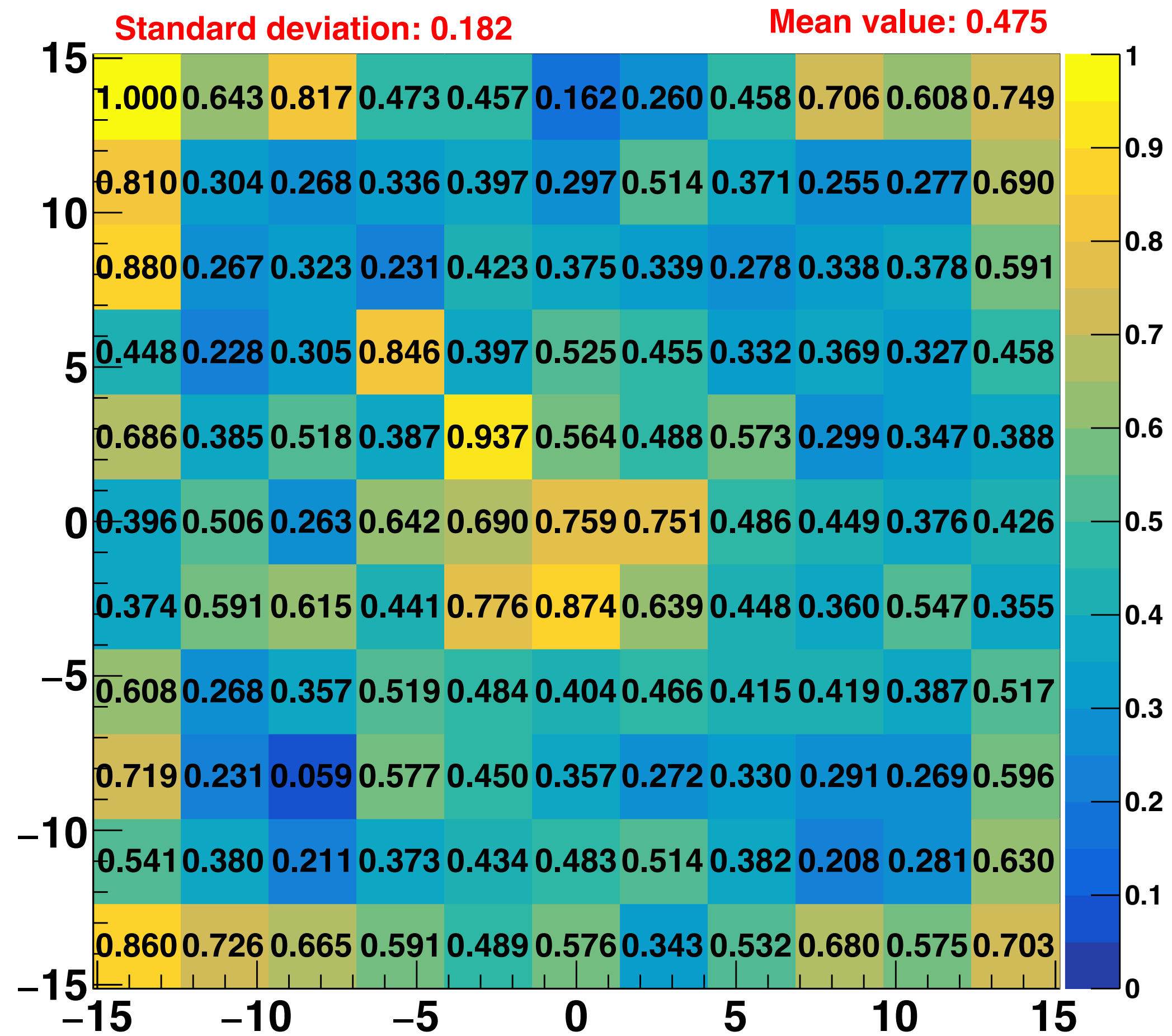

Geometry 4

AIR

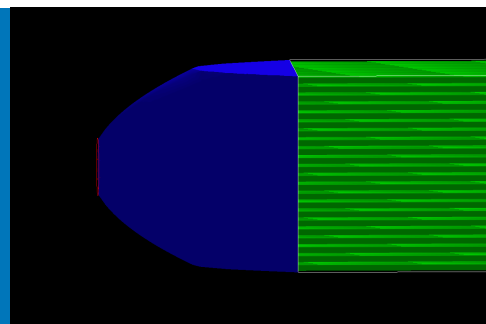

statistic 11.000 - muon 1 GeV

Winstone cone
PMT 4.5

Efficiency - LG - Air - 3cm - base round - 4.5 mm

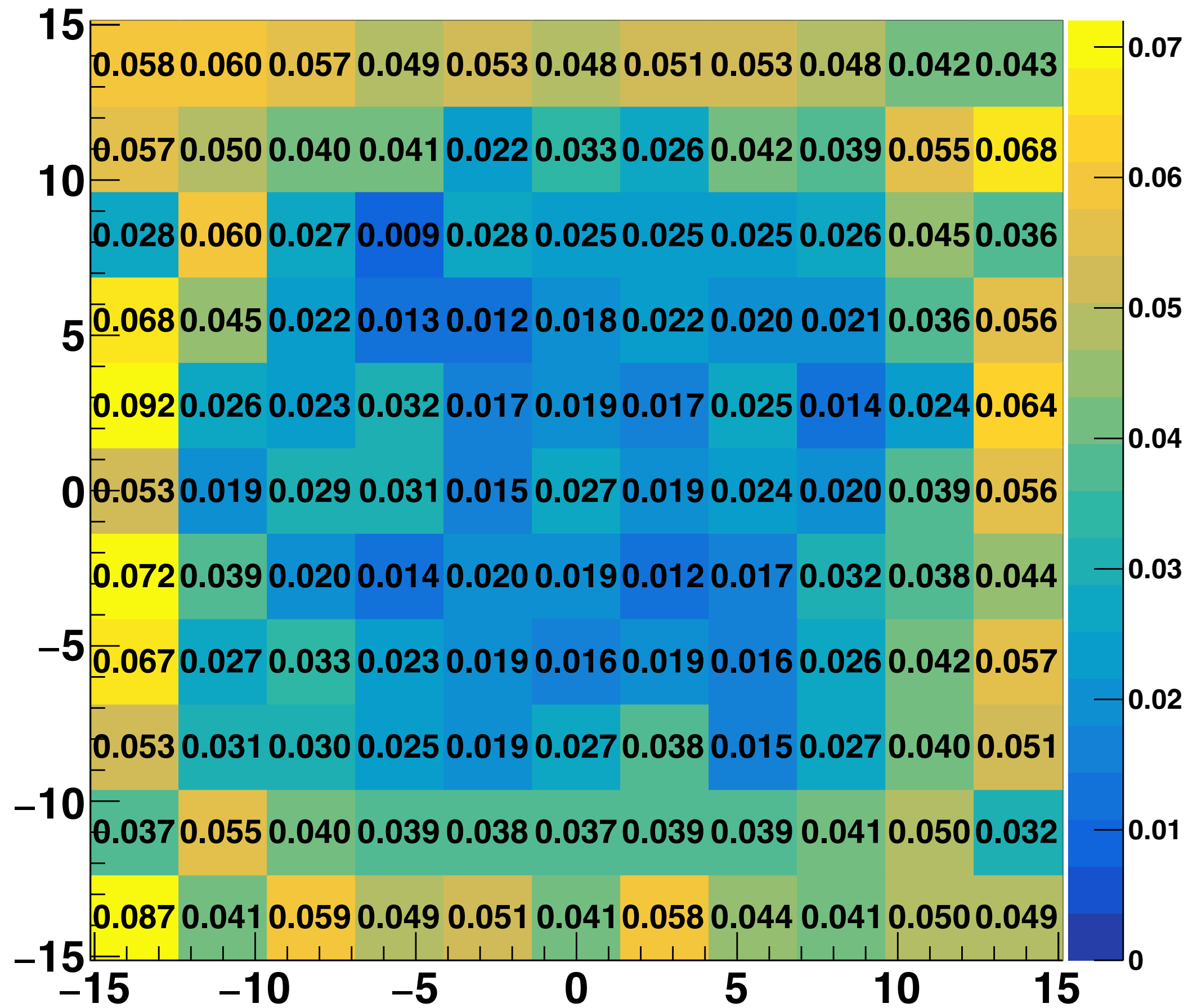

Factor non-uniformity - LG - Air - 3cm - base round - 4.5 mm

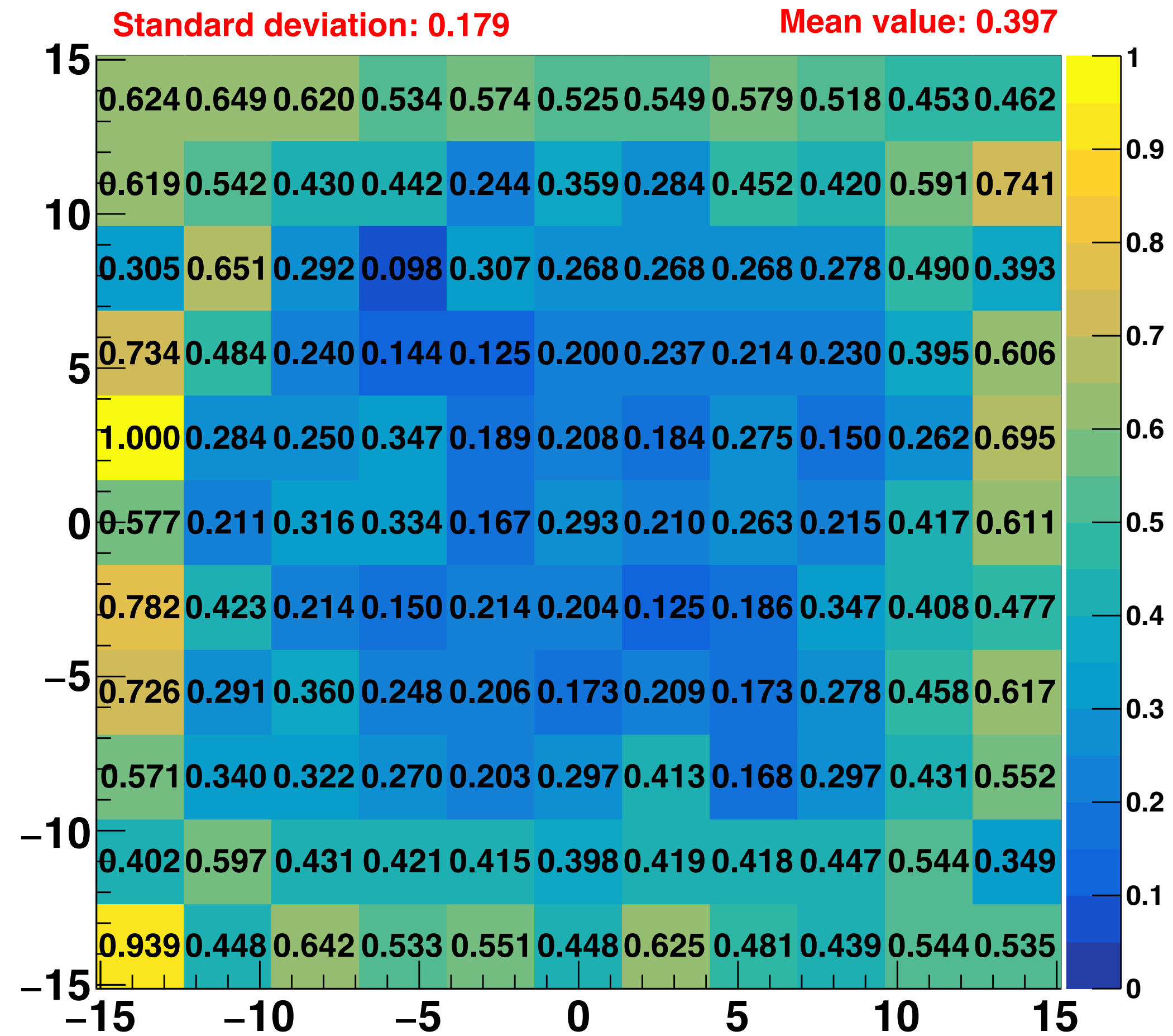

Geometry 4

AIR

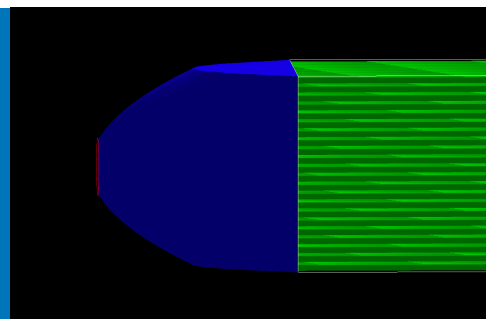

statistic 11.000 - muon 1 GeV

Winstone cone
PMT 4.5

Efficiency - LG - Air - 4cm - base round - 4.5 mm

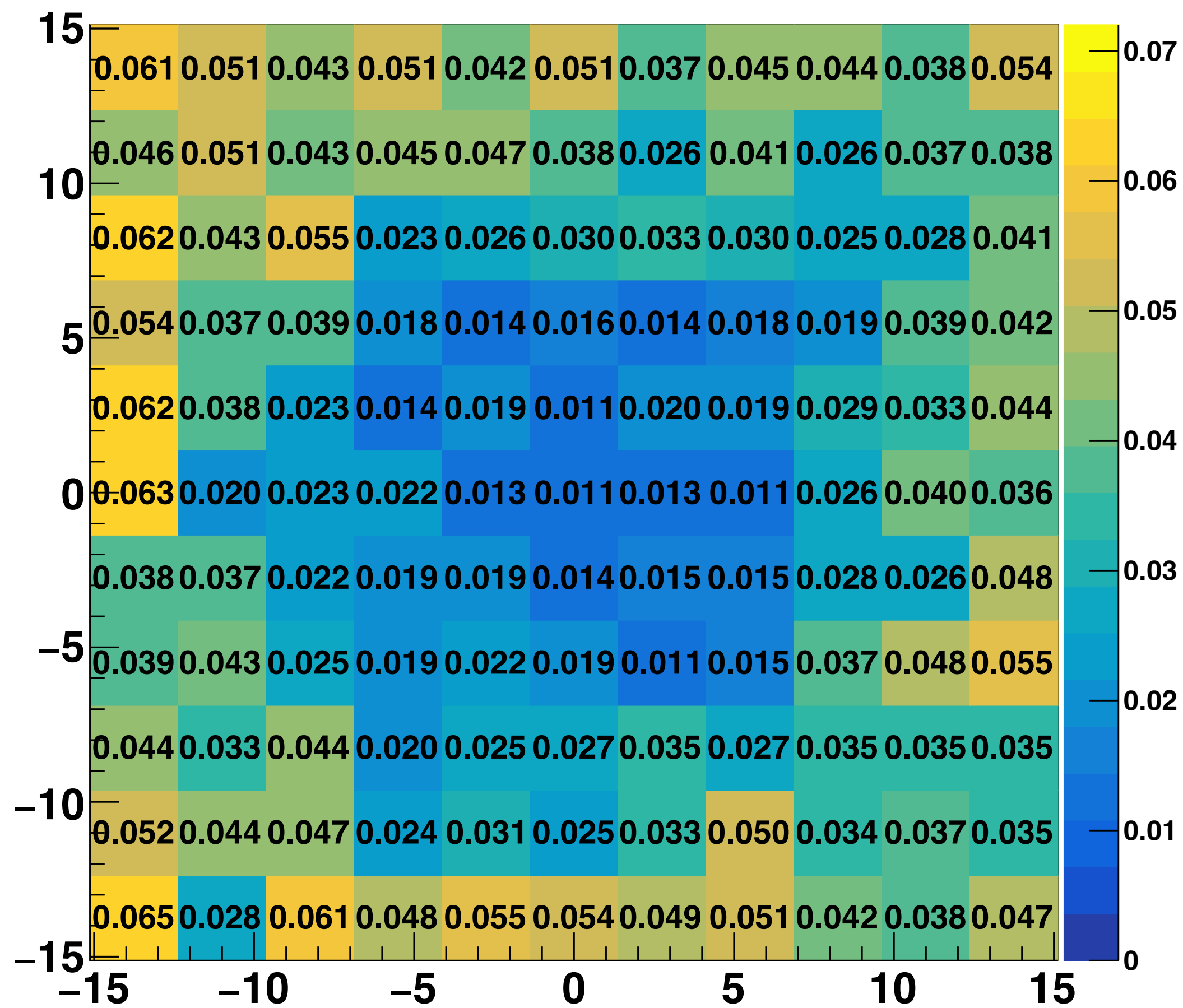

Factor non-uniformity - LG - Air - 4cm - base round - 4.5 mm

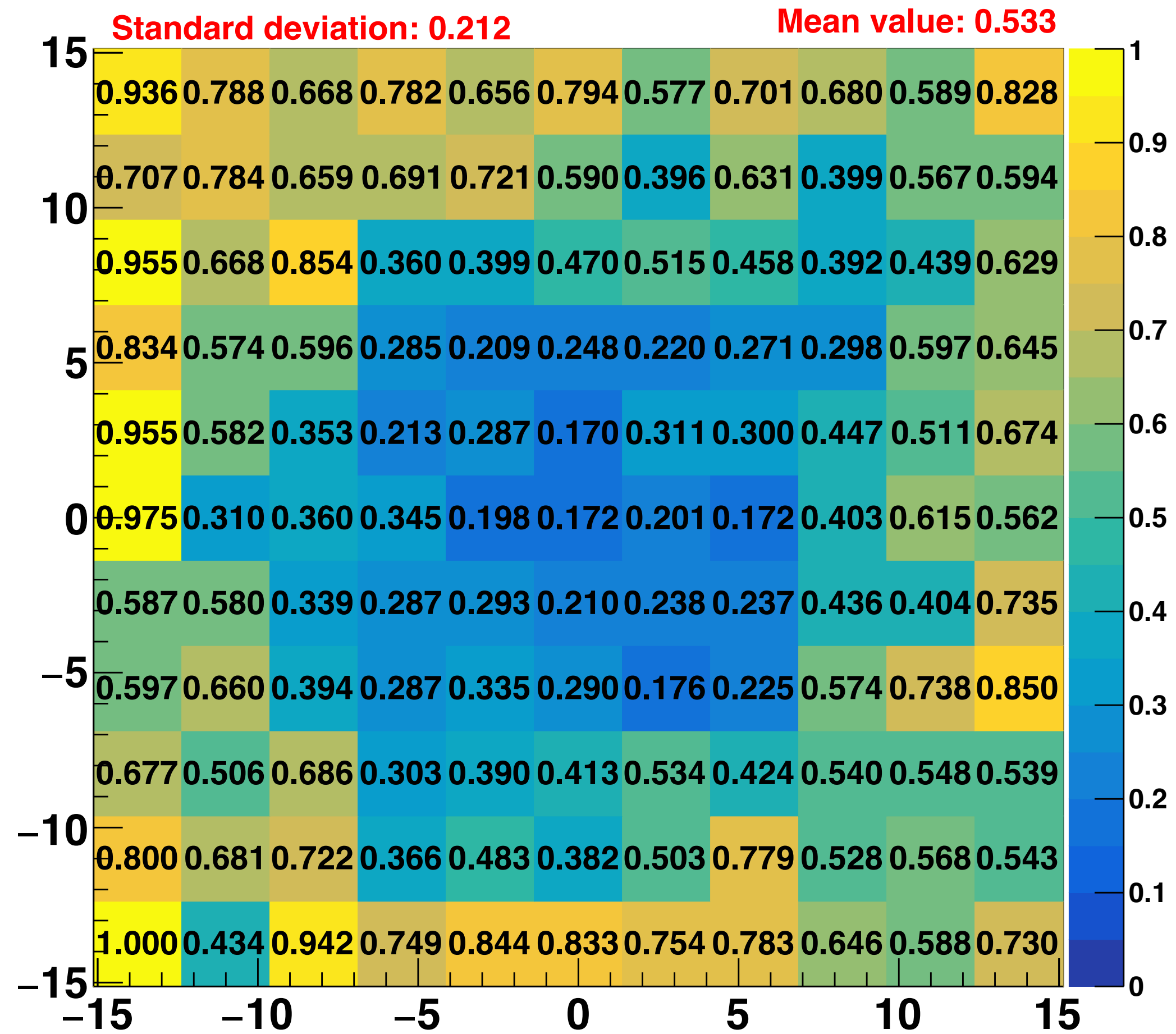

• Geometry 4

AIR

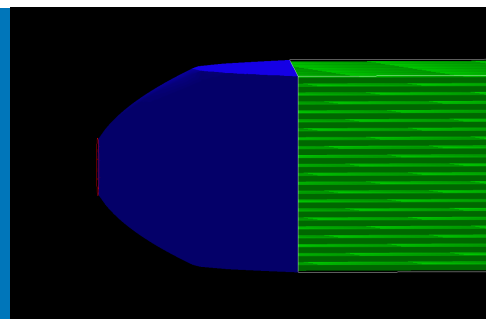

statistic 11.000 - muon 1 GeV

Winstone cone
PMT 4.5

Efficiency - LG - Air - 5cm - base round - 4.5 mm

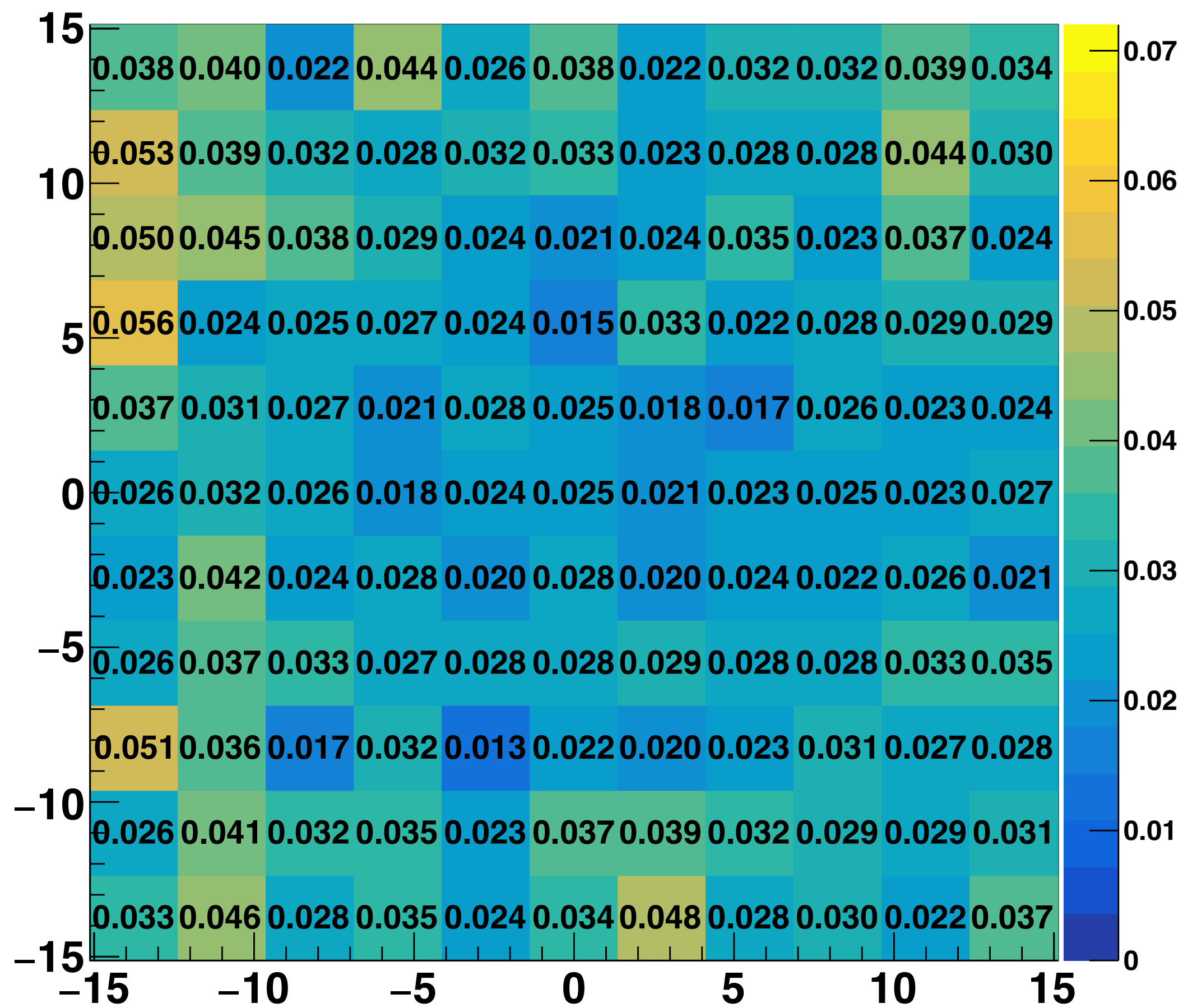

Factor non-uniformity - LG - Air - 5cm - base round - 4.5 mm

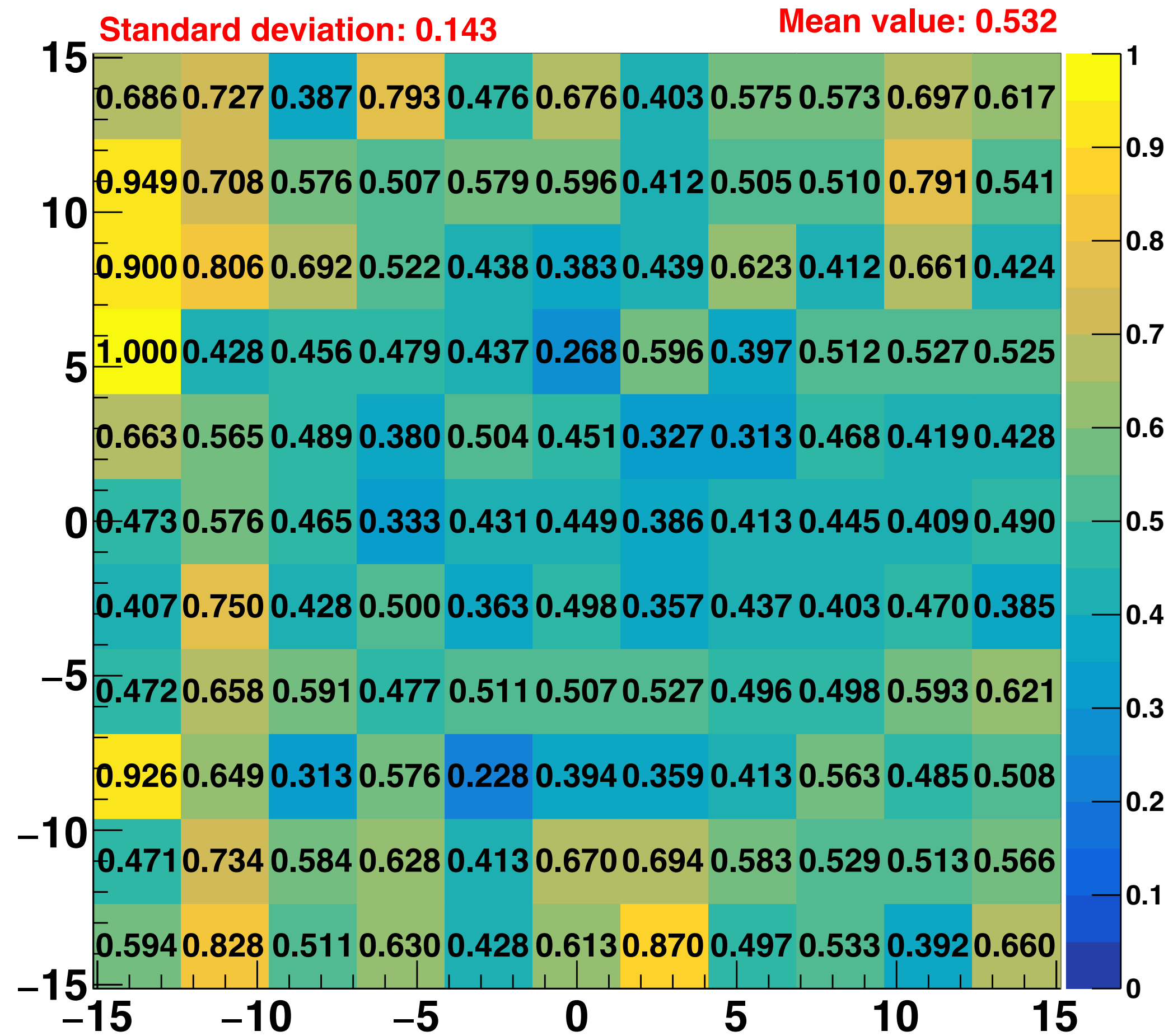

Geometry 4

AIR

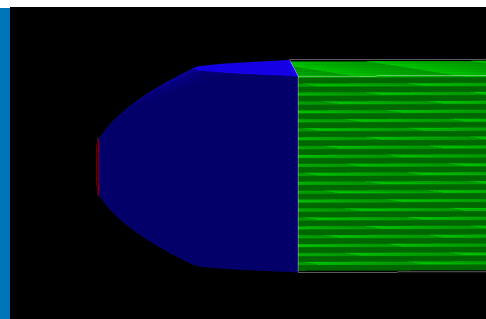

statistic 11.000 - muon 1 GeV

Winstone cone
PMT 4.5

Efficiency - LG - Air - 6cm - base round - 4.5 mm

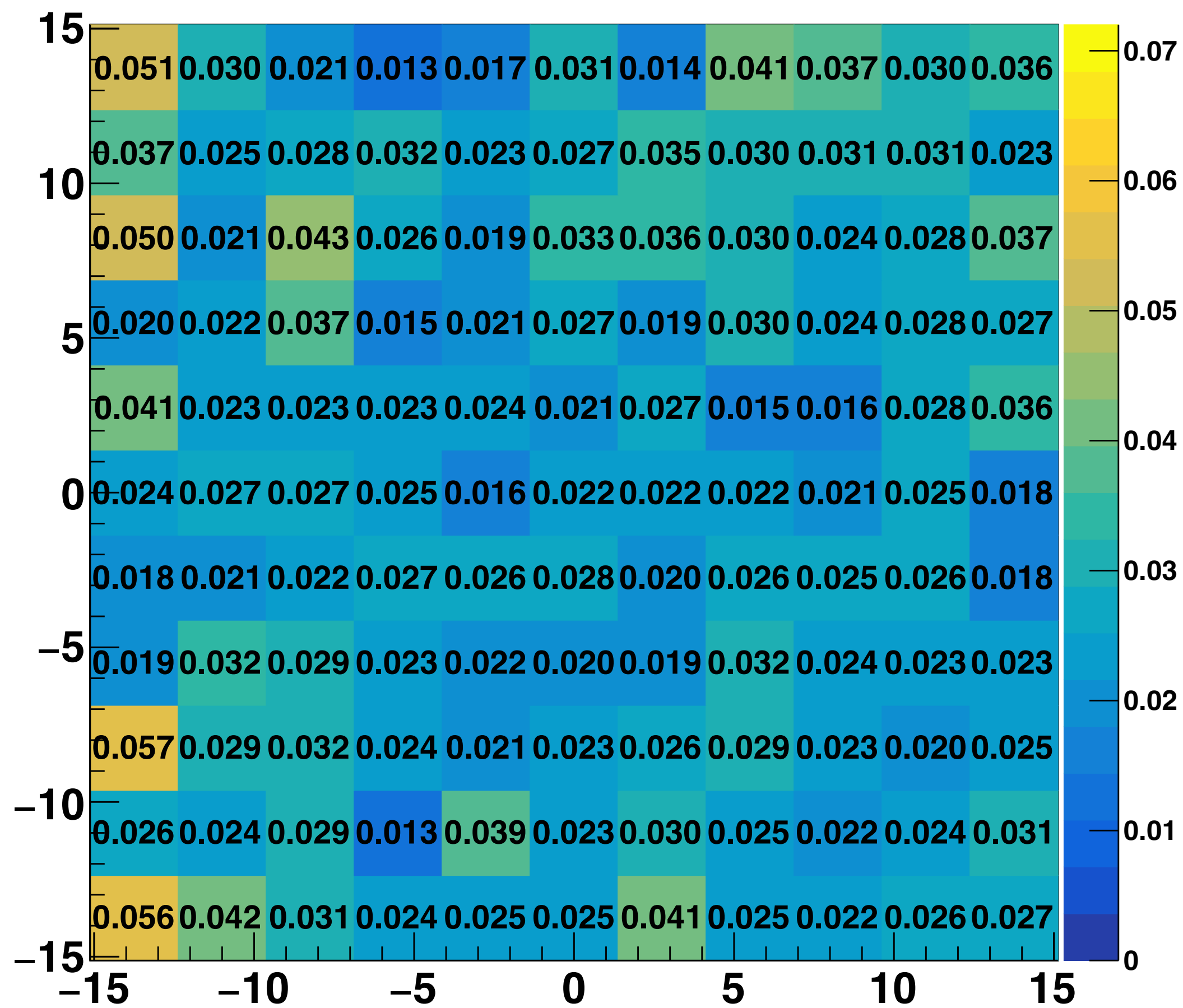

Factor non-uniformity - LG - Air - 6cm - base round - 4.5 mm

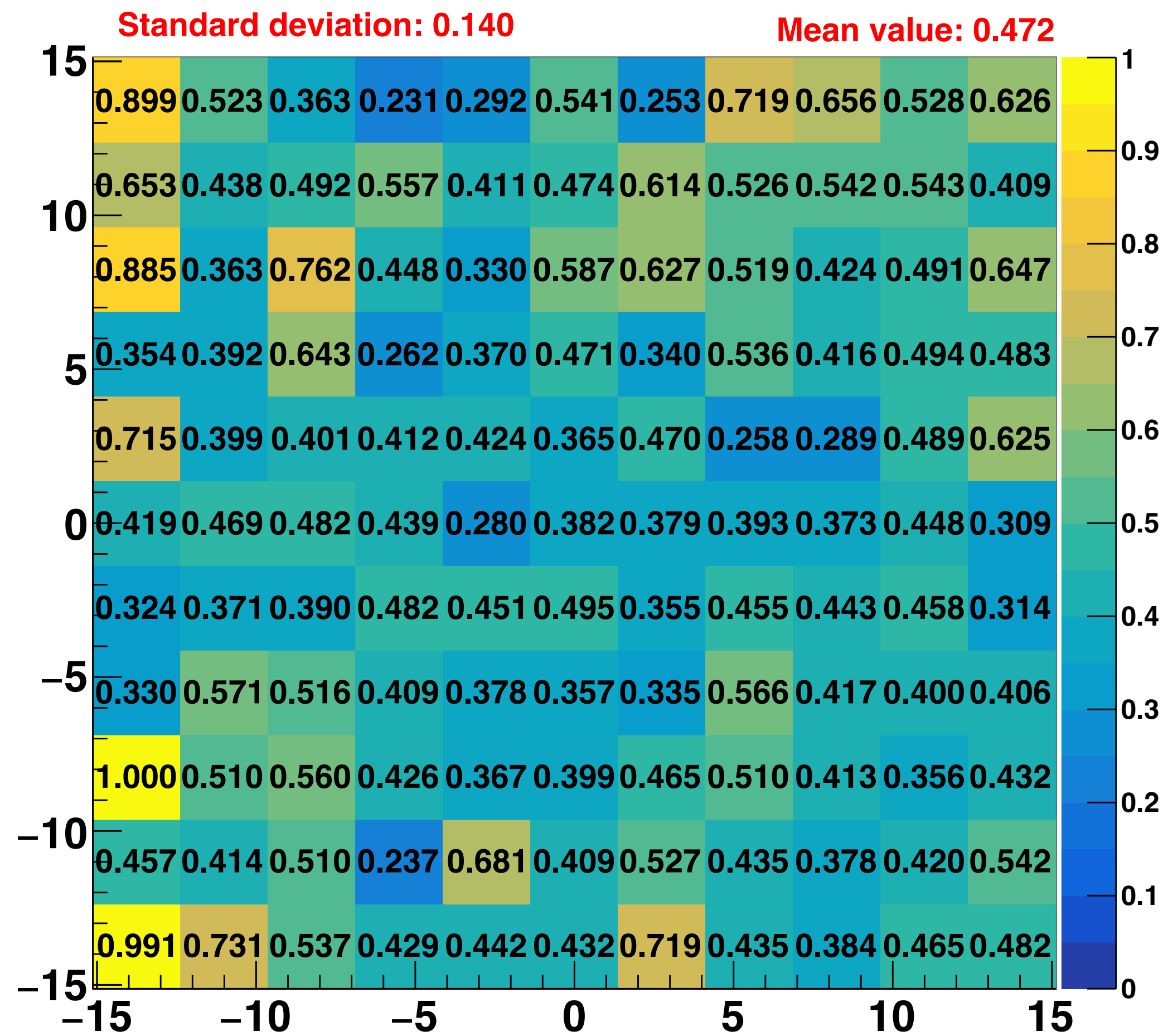

Geometry 4 -- PMMA - WC

Gr

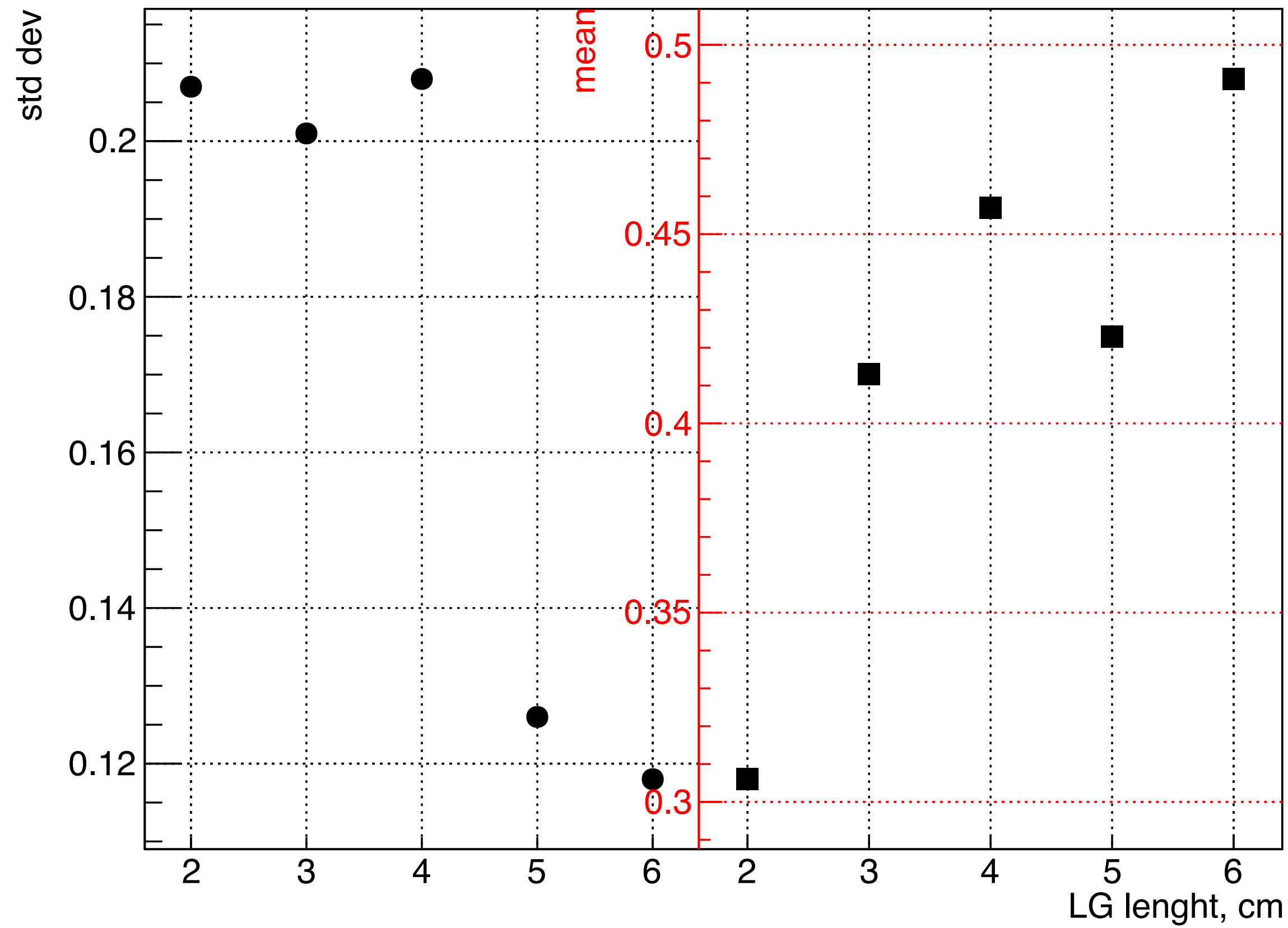

Geometry 4 -- AIR - WC

Graph

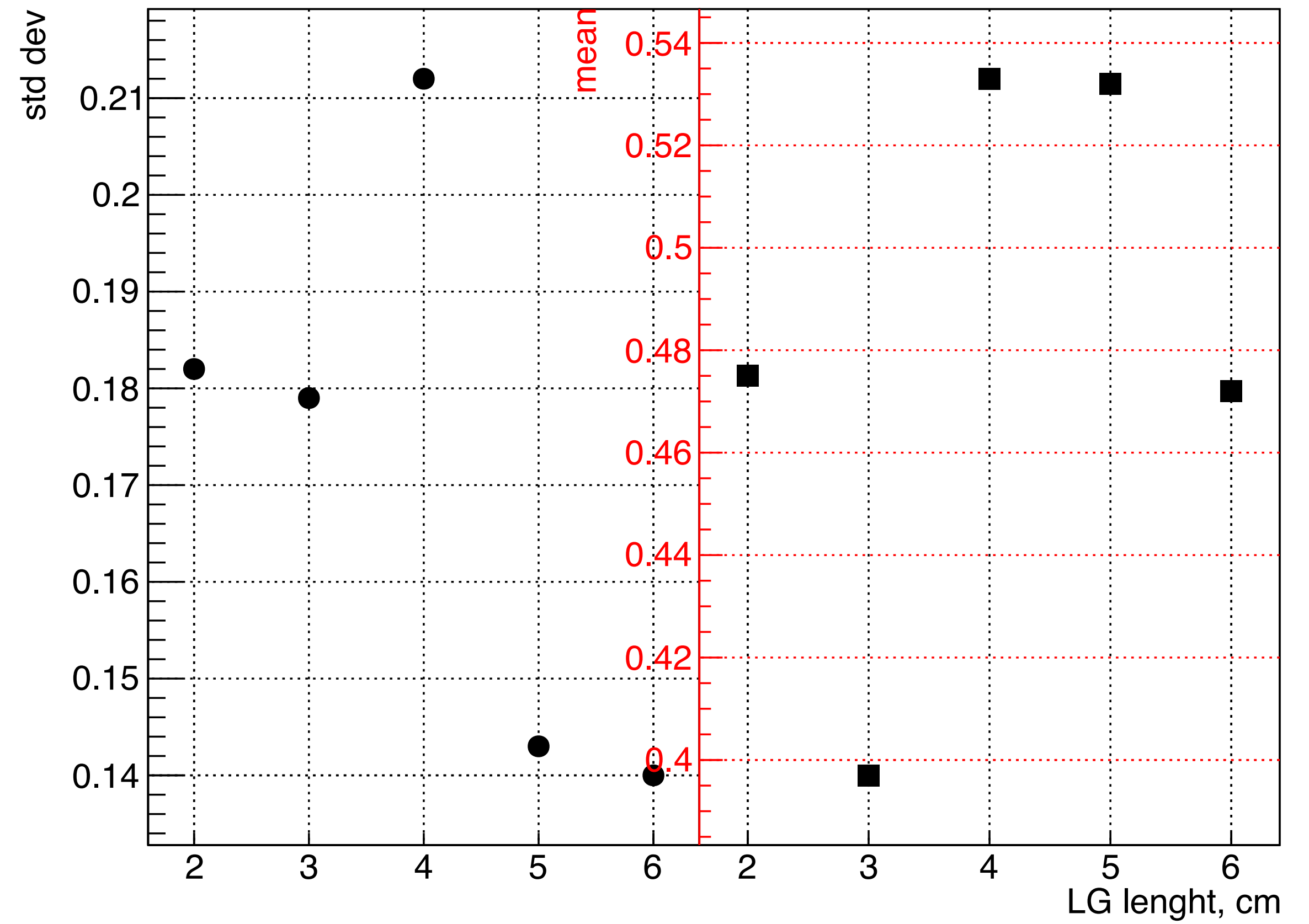

- **Geometry 4.2**

PMMA

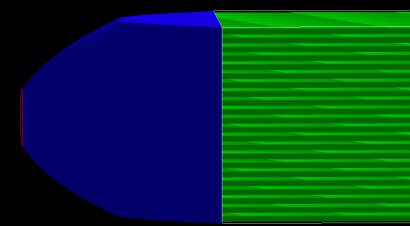

statistic 11.000 - muon 1 GeV

Winstone cone
PMT 11mm

Geometry 4

PMMA

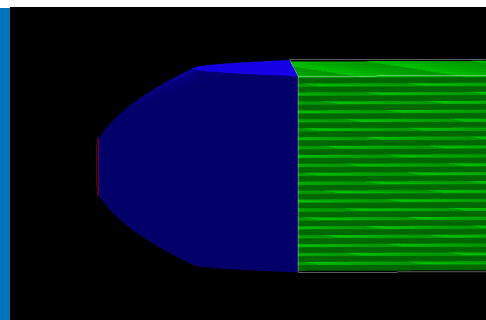

Statistic 11.000 - muon 1 GeV

Winstone cone
PMT 11

Efficiency - LG - PMMA - 2cm - base round - 11. mm

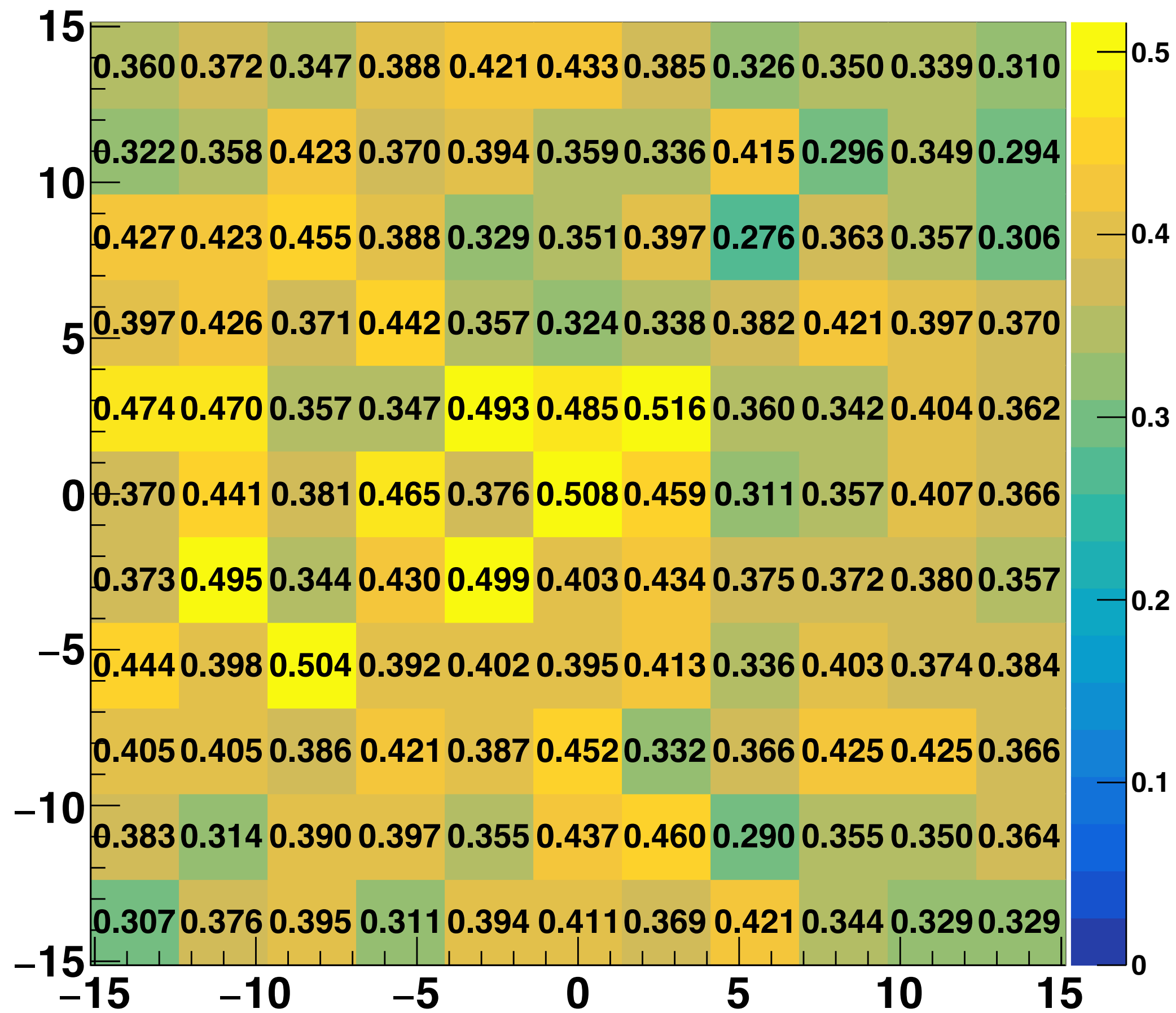

Factor non-uniformity - LG - PMMA - 2cm - base round - 11. mm

Standard deviation: 0.097

Mean value: 0.748

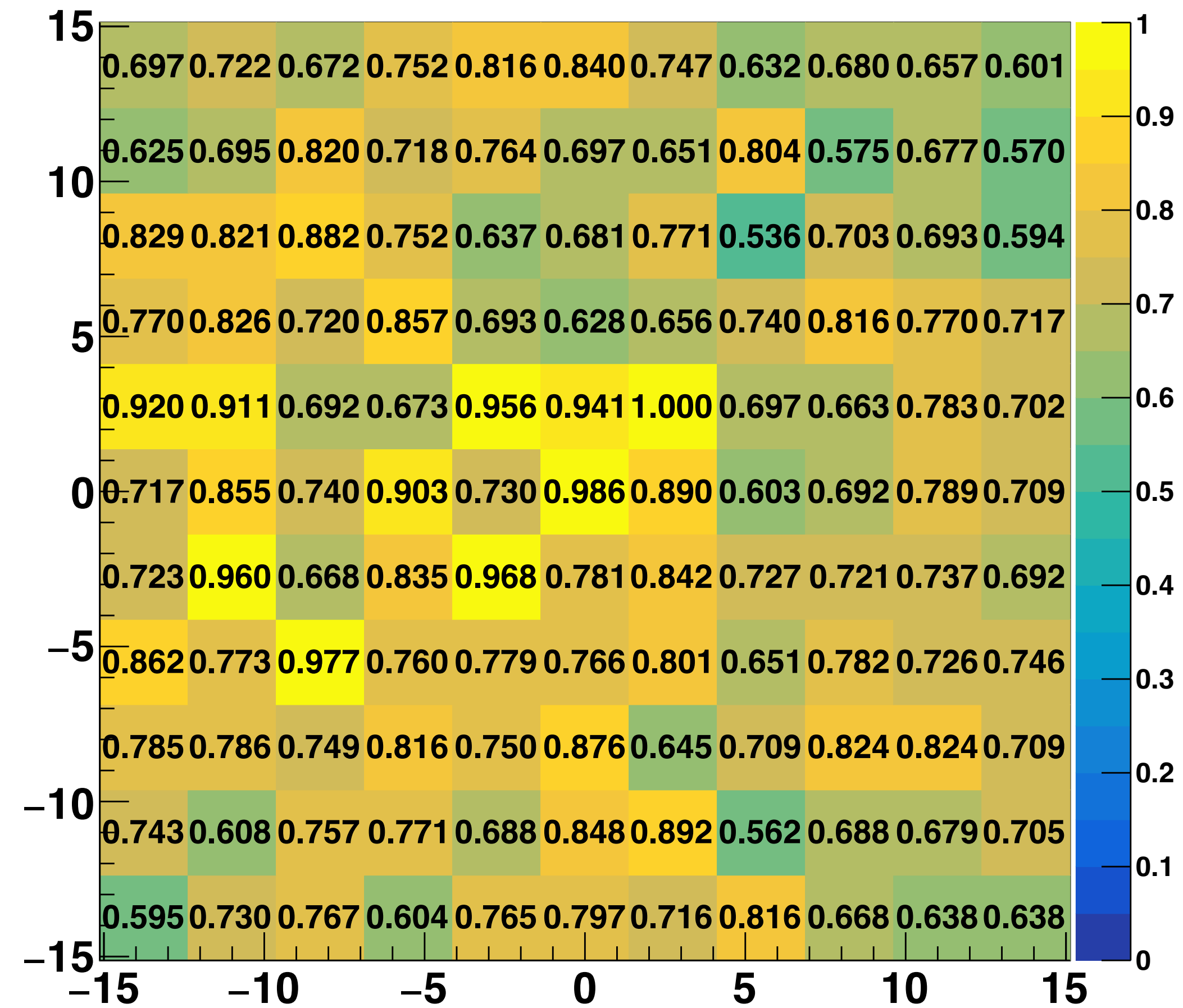

Geometry 4

PMMA

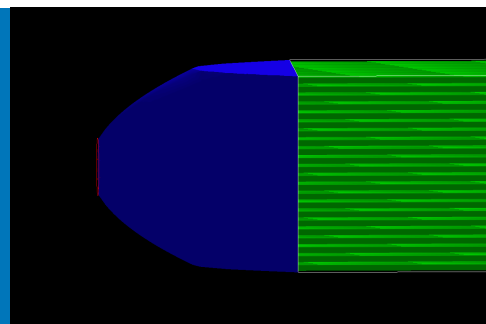

statistic 11.000 - muon 1 GeV

Winstone cone
PMT 11

Efficiency - LG - PMMA - 3cm - base round - 11. mm

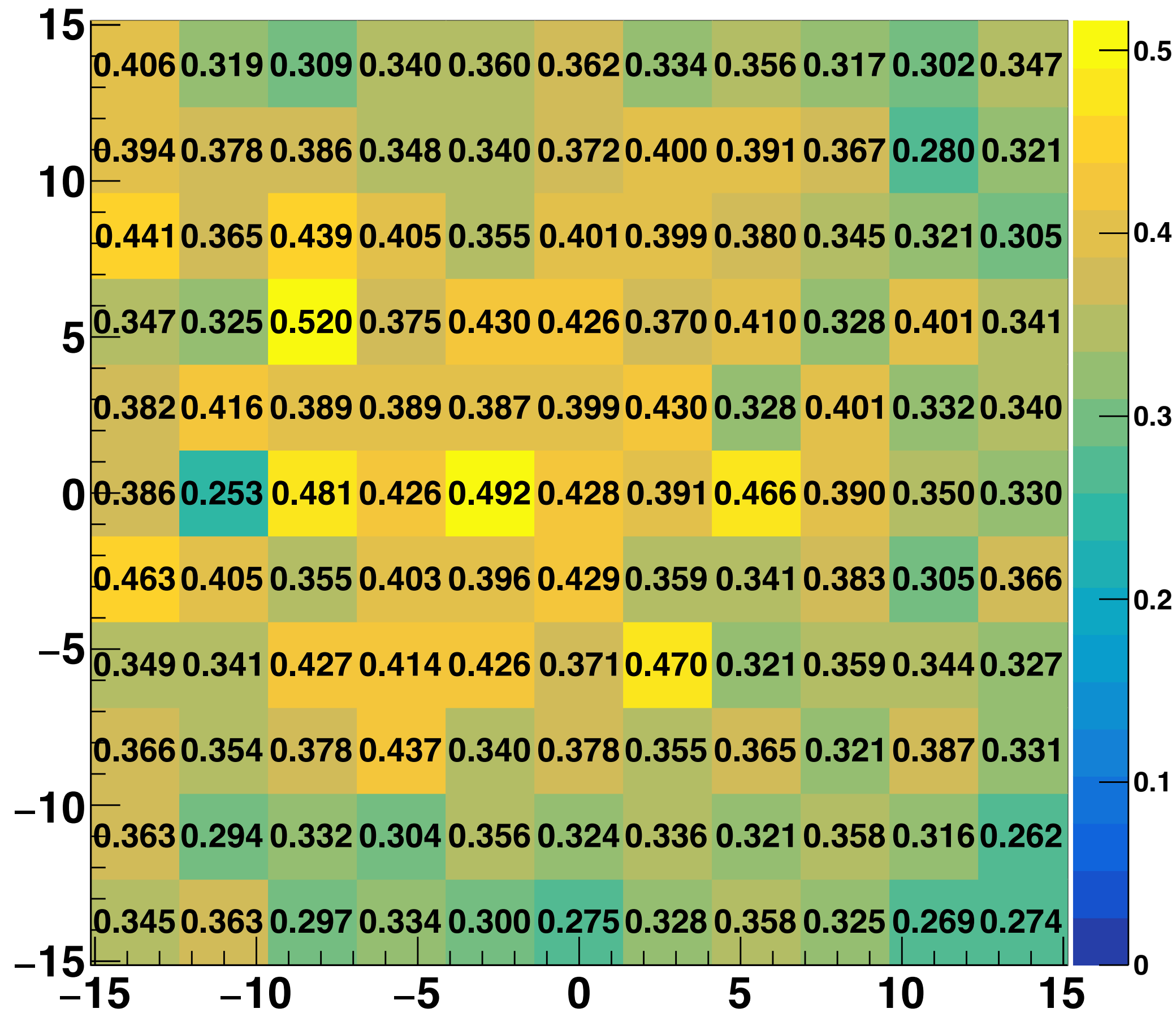

Factor non-uniformity - LG - PMMA - 3cm - base round - 11. mm

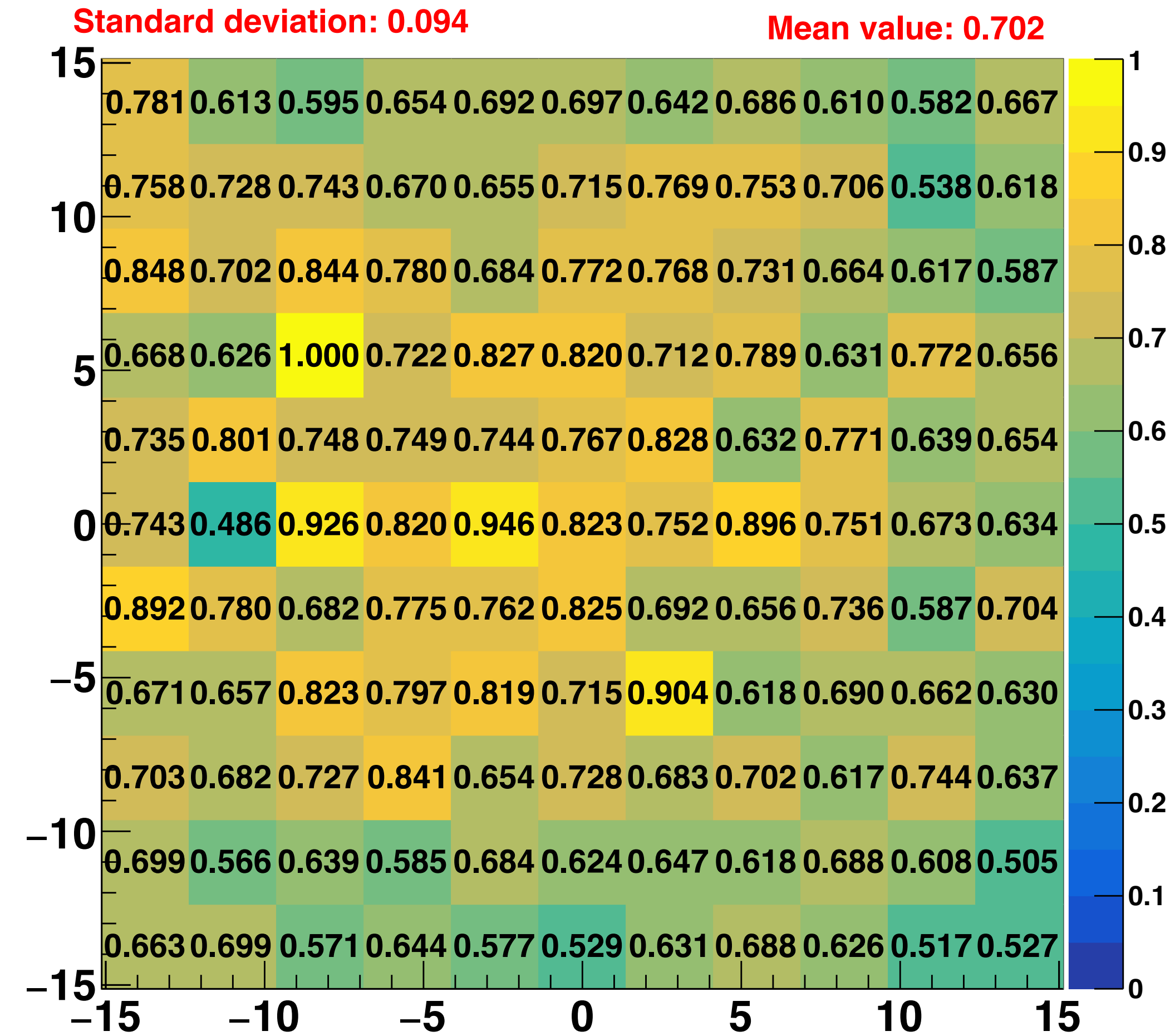

Geometry 4

PMMA

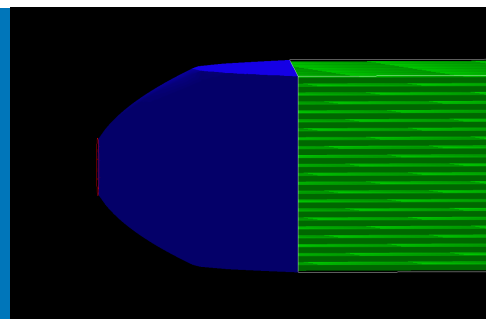

Statistic 11.000 - muon 1 GeV

Winstone cone
PMT 11

Efficiency - LG - PMMA - 4cm - base round - 11. mm

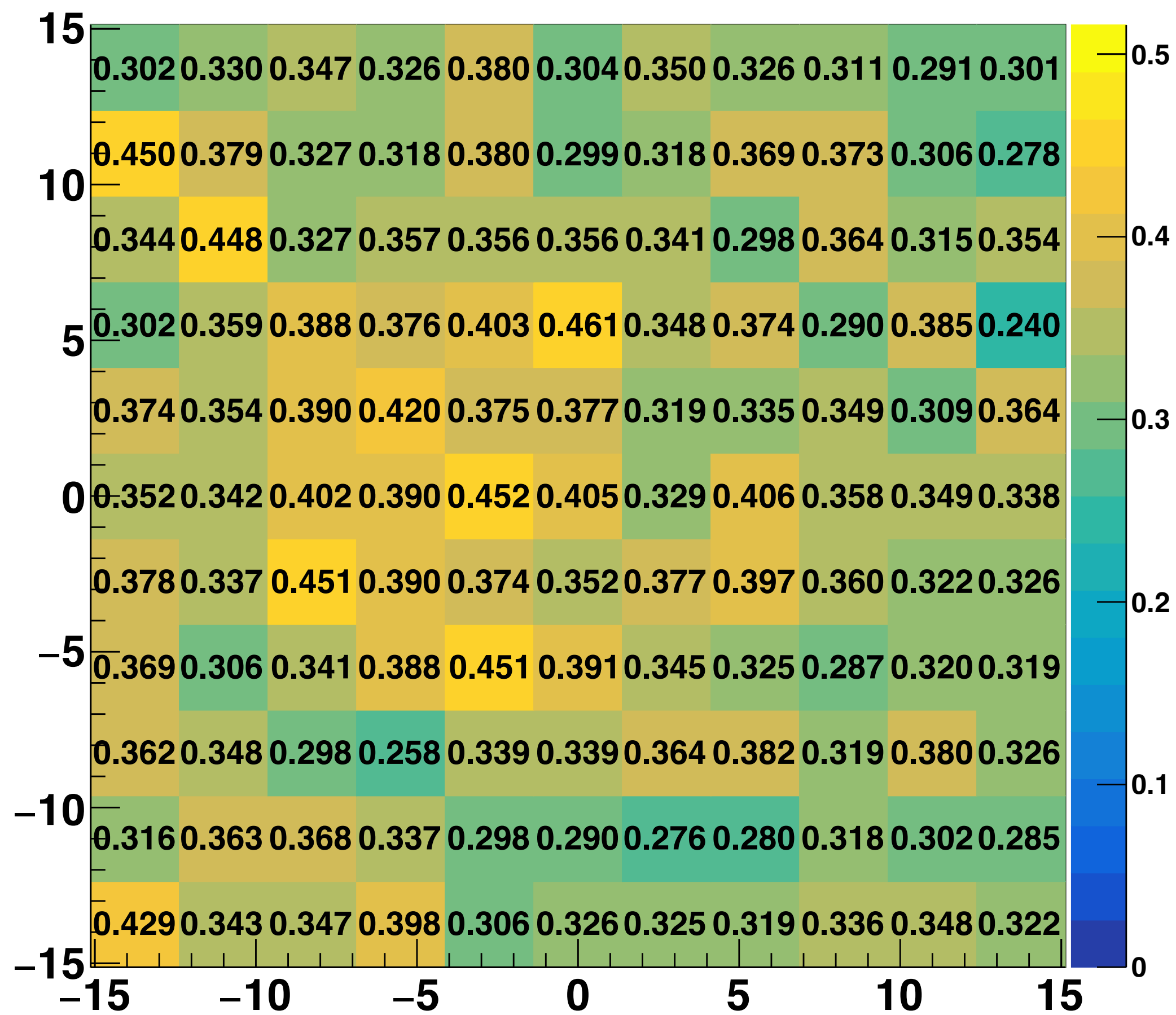

Factor non-uniformity - LG - PMMA - 4cm - base round - 11. mm

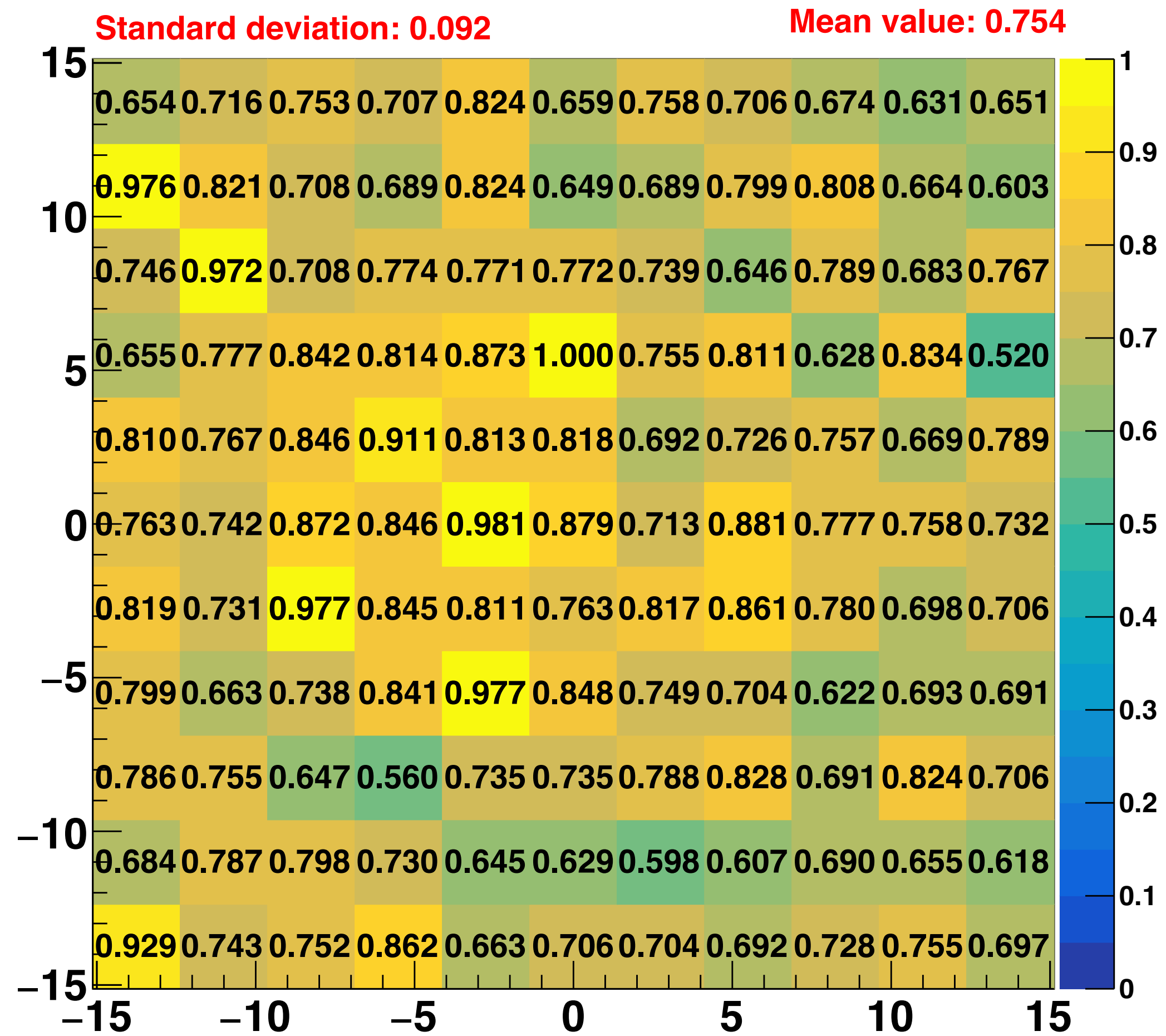

Geometry 4

PMMA

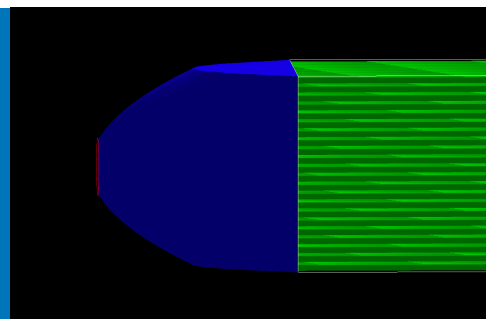

Statistic 11.000 - muon 1 GeV

Winstone cone
PMT 11

Efficiency - LG - PMMA - 5cm - base round - 11. mm

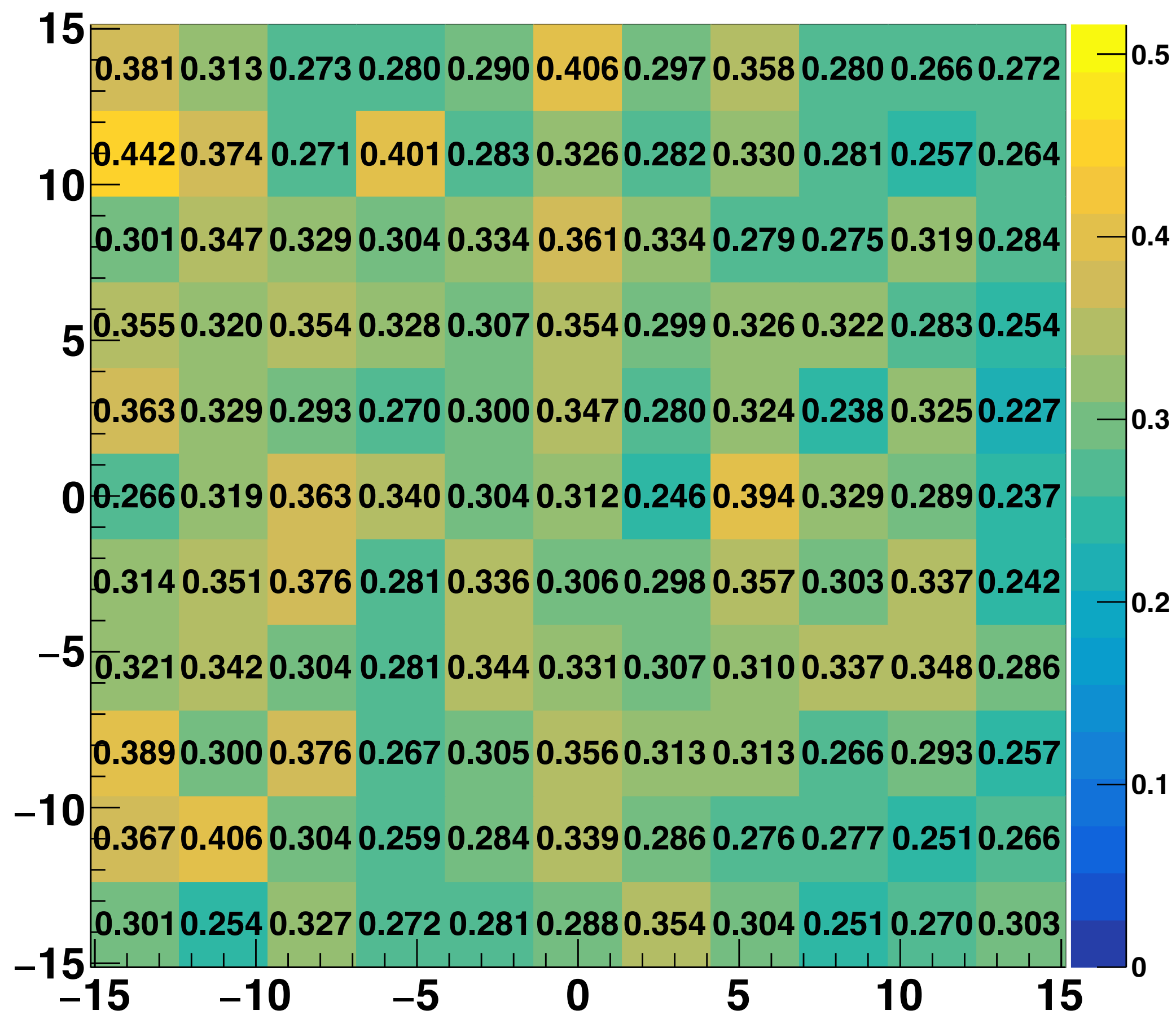

Factor non-uniformity - LG - PMMA - 5cm - base round - 11. mm

Standard deviation: 0.093

Mean value: 0.702

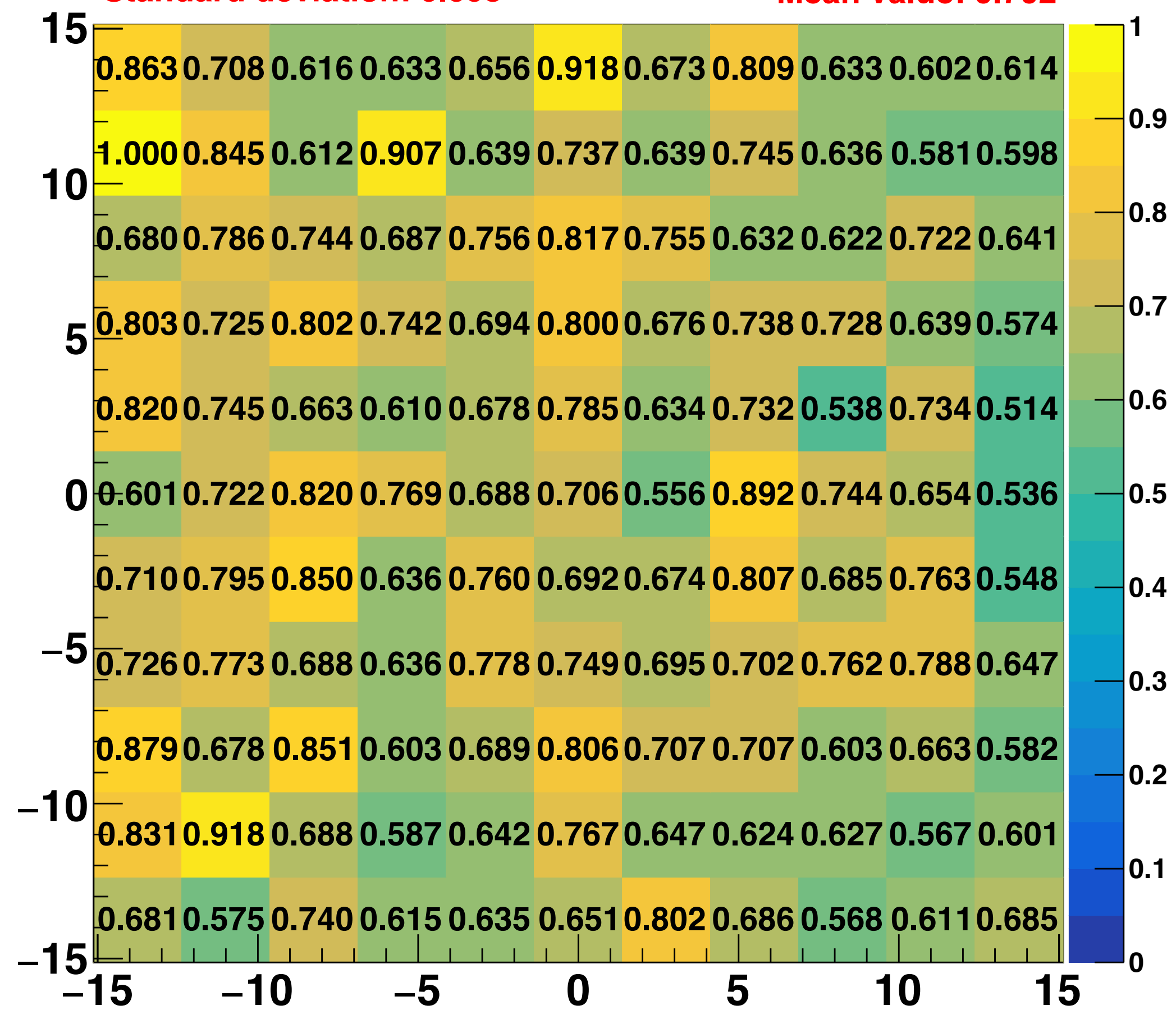

Geometry 4

PMMA

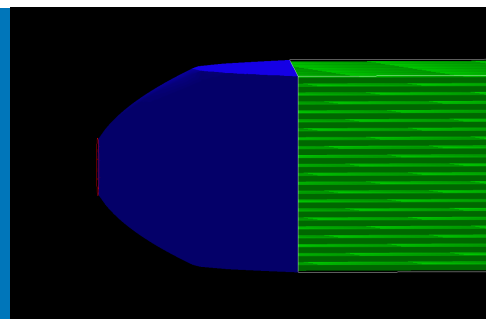

Statistic 11.000 - muon 1 GeV

Winstone cone
PMT 11

Efficiency - LG - PMMA - 6cm - base round - 11. mm

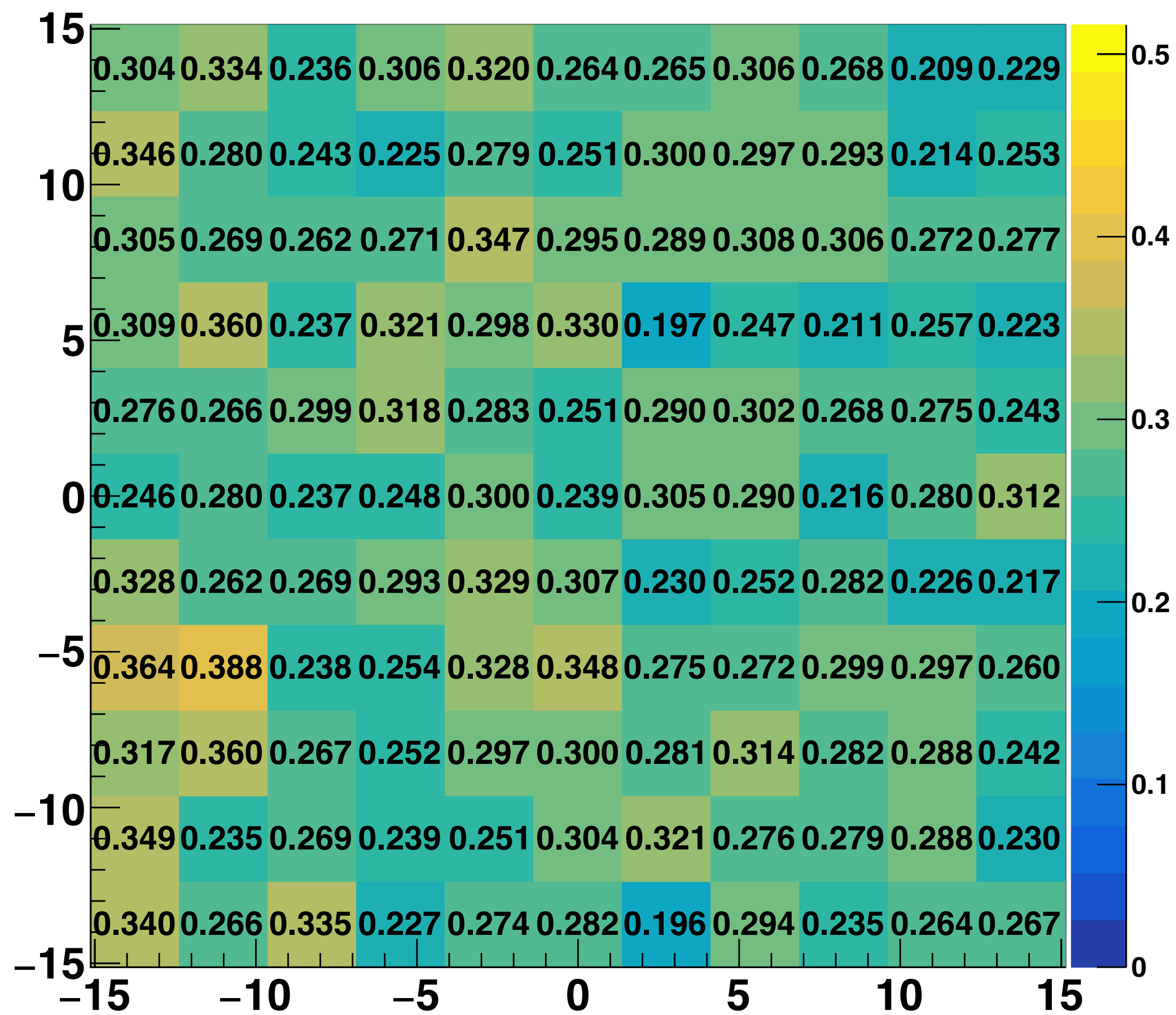

Factor non-uniformity - LG - PMMA - 6cm - base round - 11. mm

Standard deviation: 0.099

Mean value: 0.719

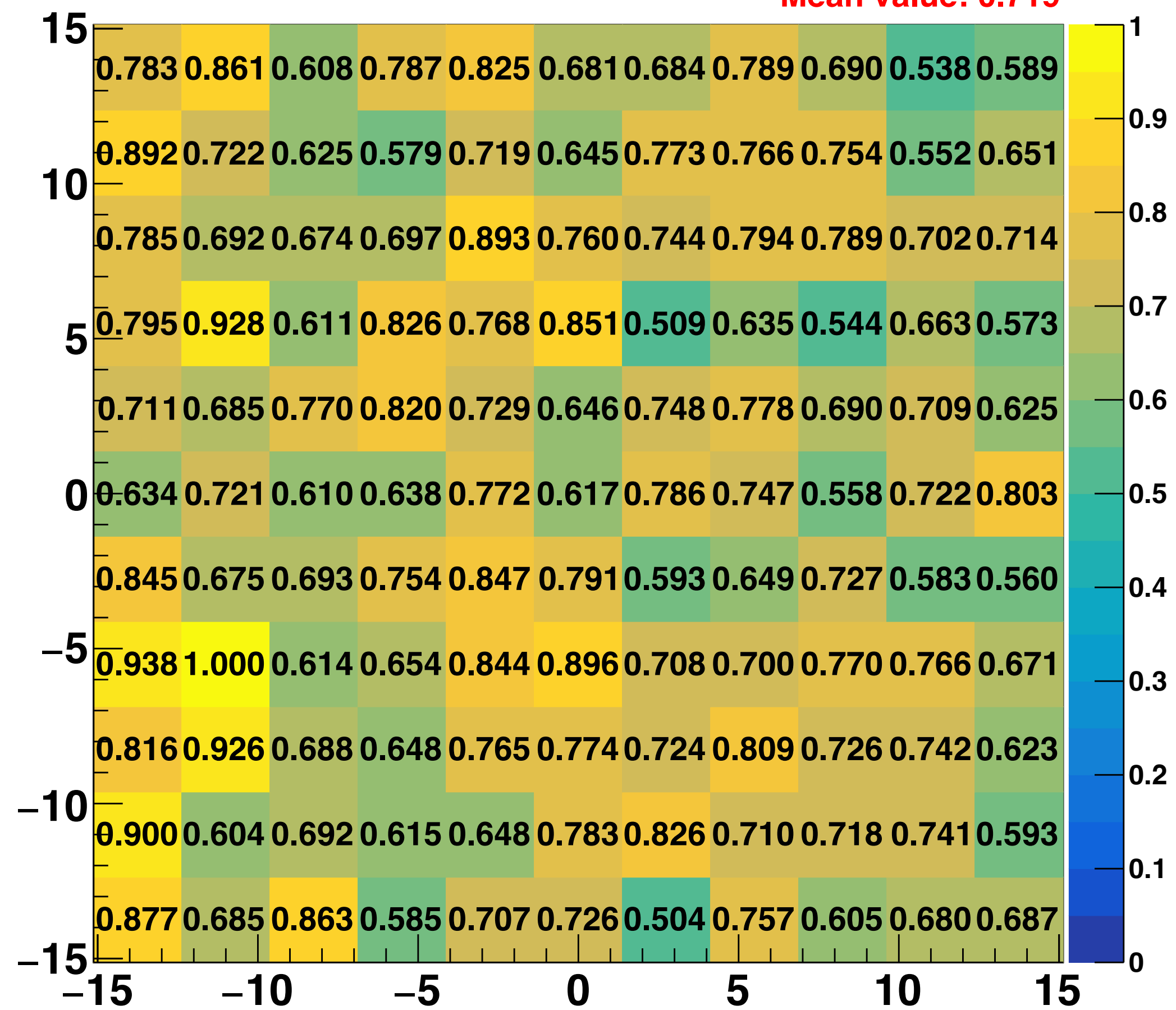

Geometry 4

AIR

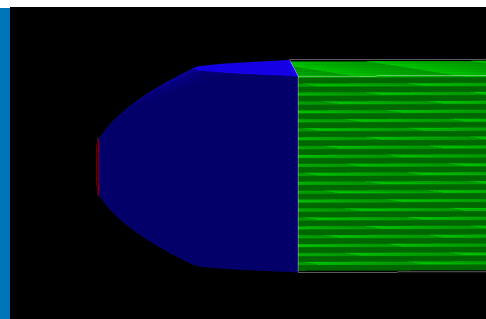

statistic 11.000 - muon 1 GeV

Winstone cone
PMT 11

Efficiency - LG - Air - 2cm - base round - 11. mm

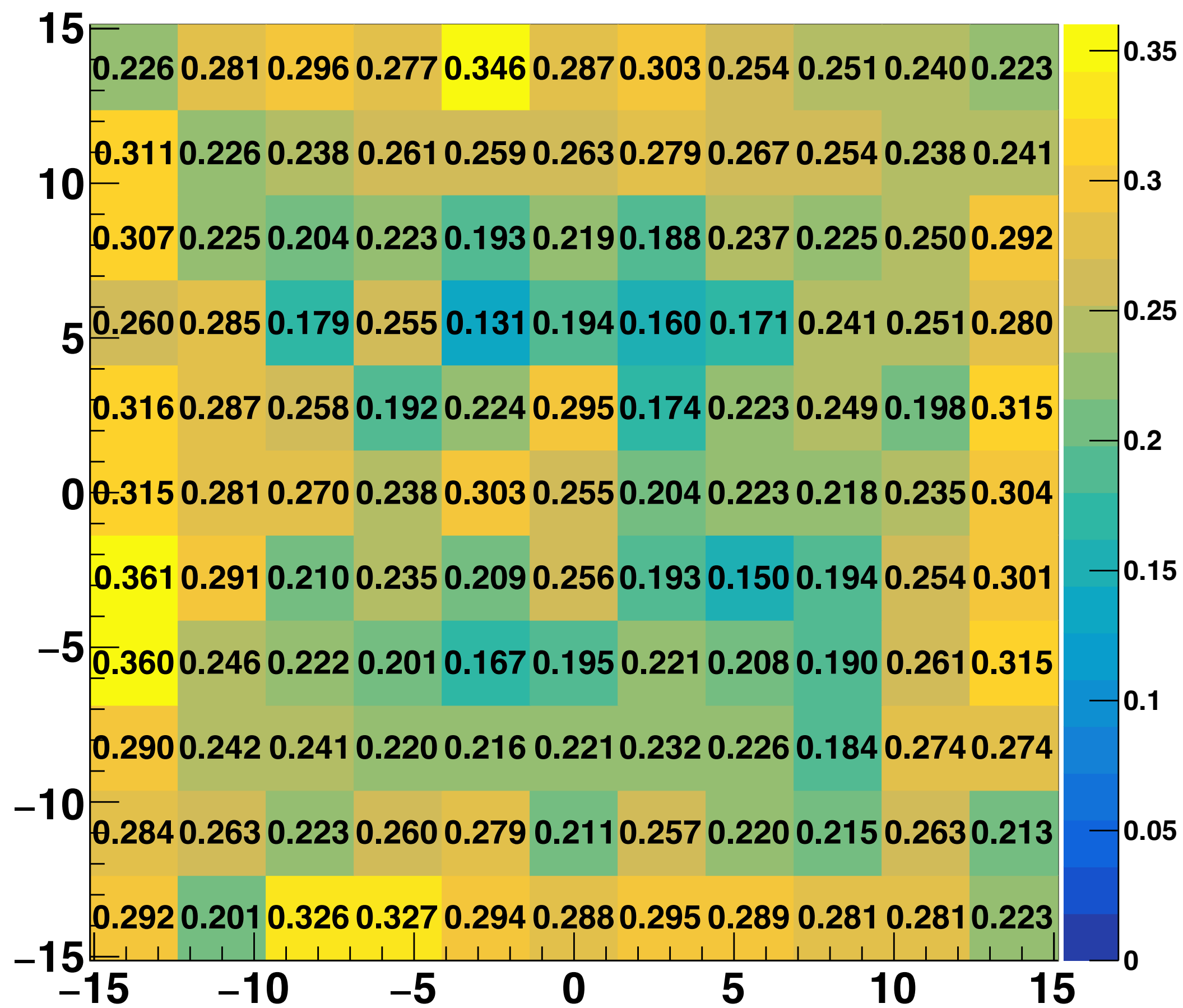

Factor non-uniformity - LG - Air - 2cm - base round - 11. mm

Standard deviation: 0.123

Mean value: 0.687

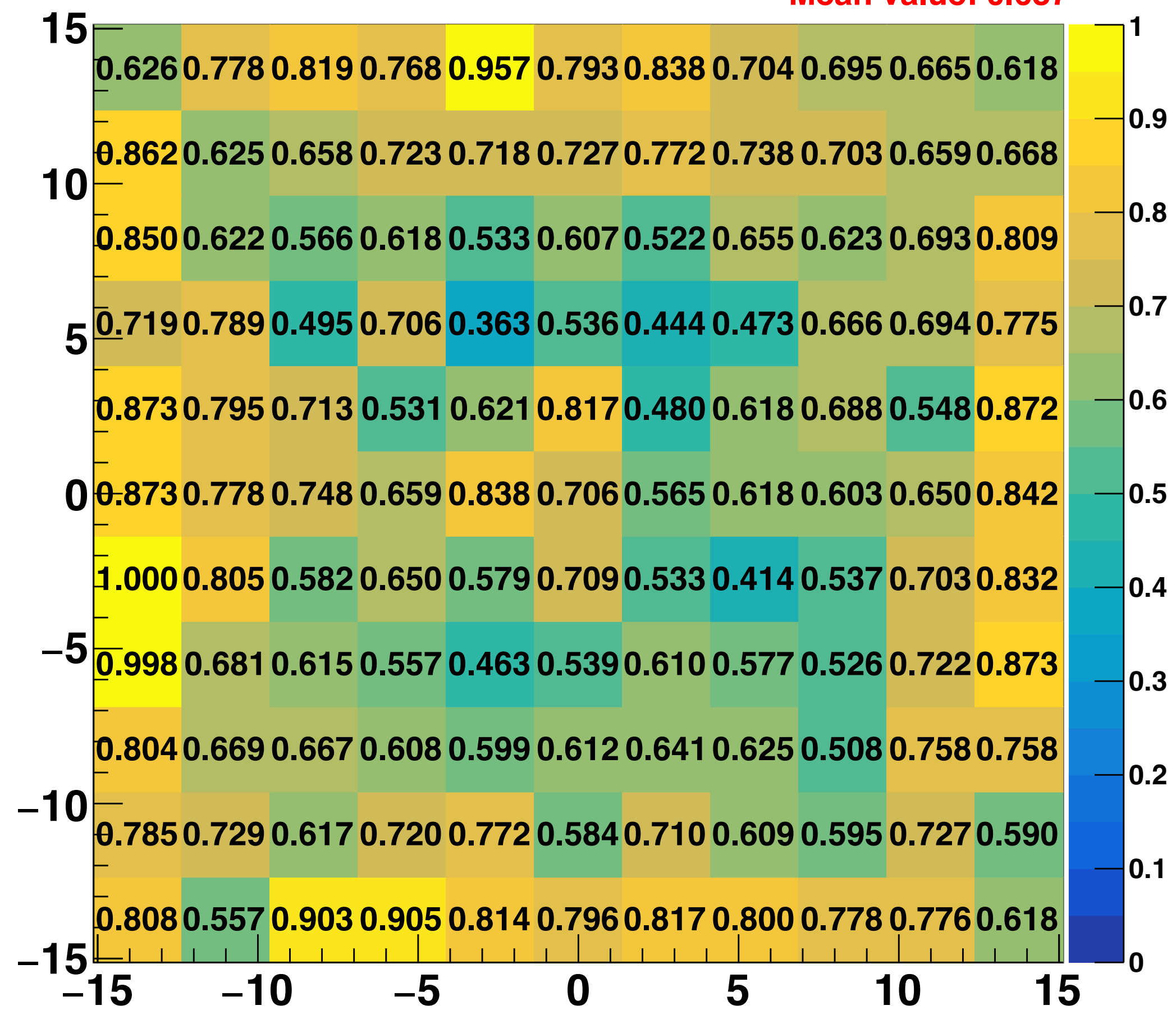

Geometry 4

AIR

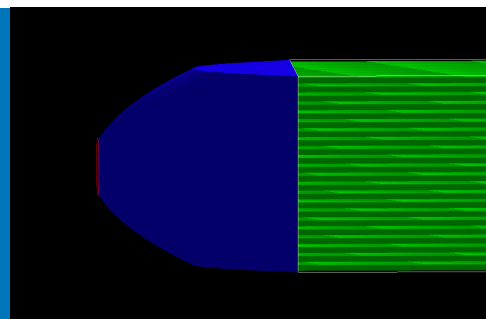

statistic 11.000 - muon 1 GeV

Winstone cone
PMT 11

Efficiency - LG - Air - 3cm - base round - 11. mm

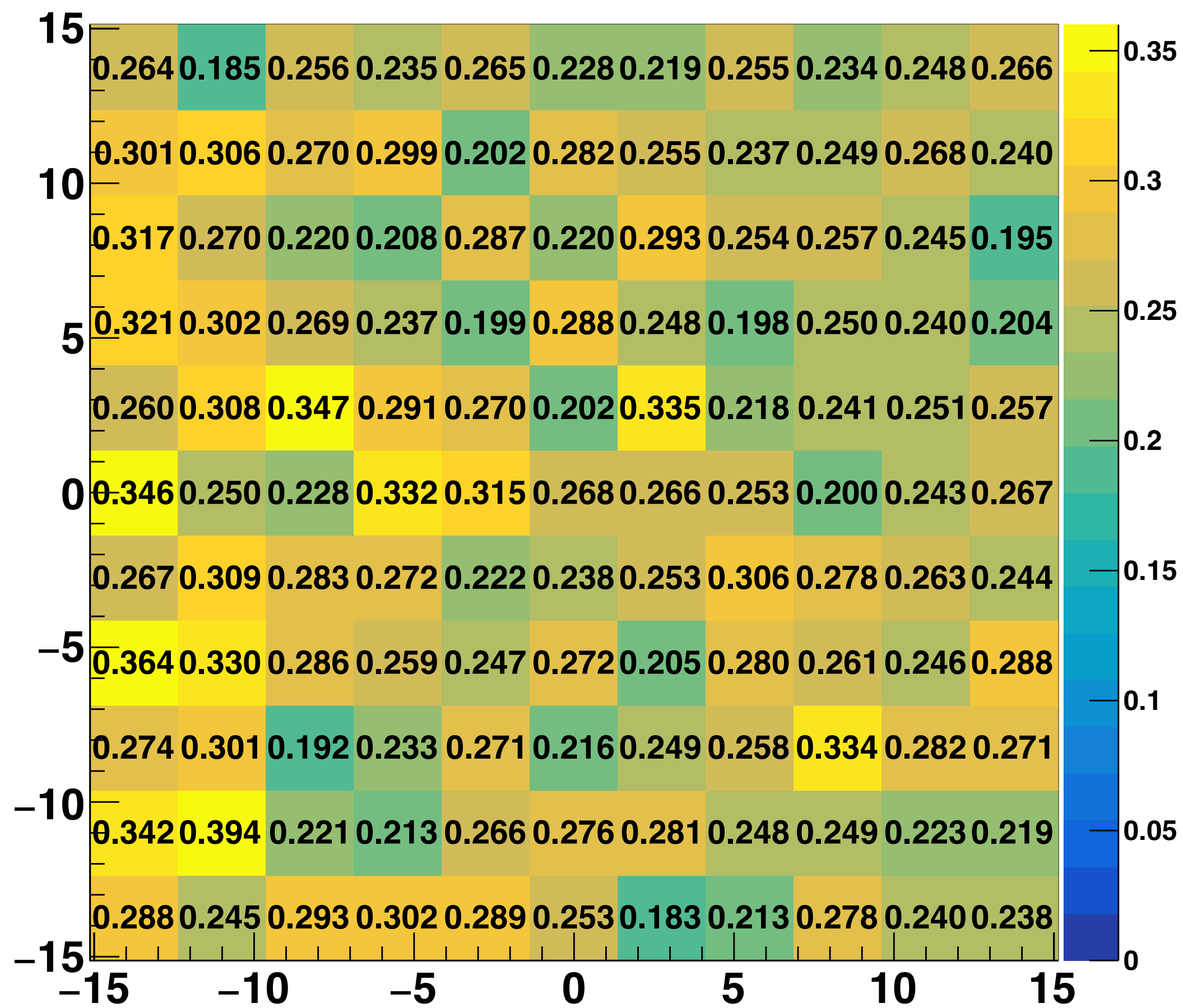

Factor non-uniformity - LG - Air - 3cm - base round - 11. mm

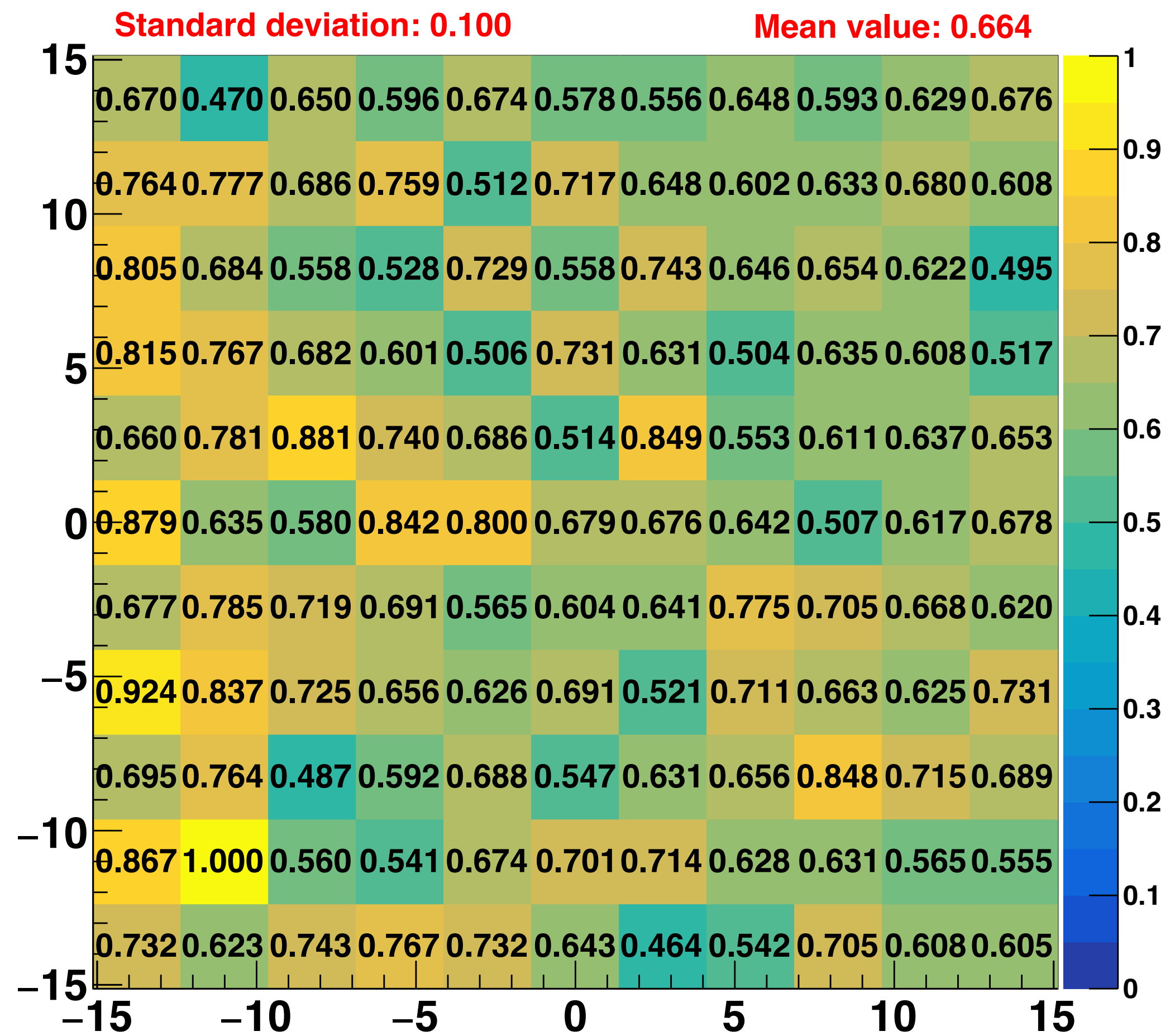

• Geometry 4

AIR

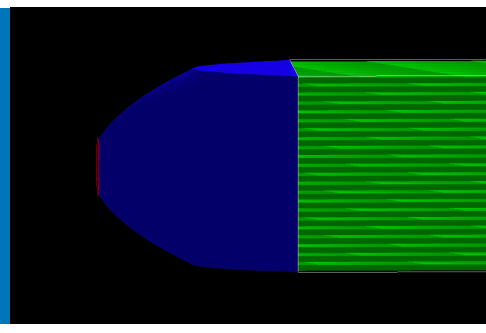

statistic 11.000 - muon 1 GeV

Winstone cone
PMT 11

Efficiency - LG - Air - 4cm - base round - 11. mm

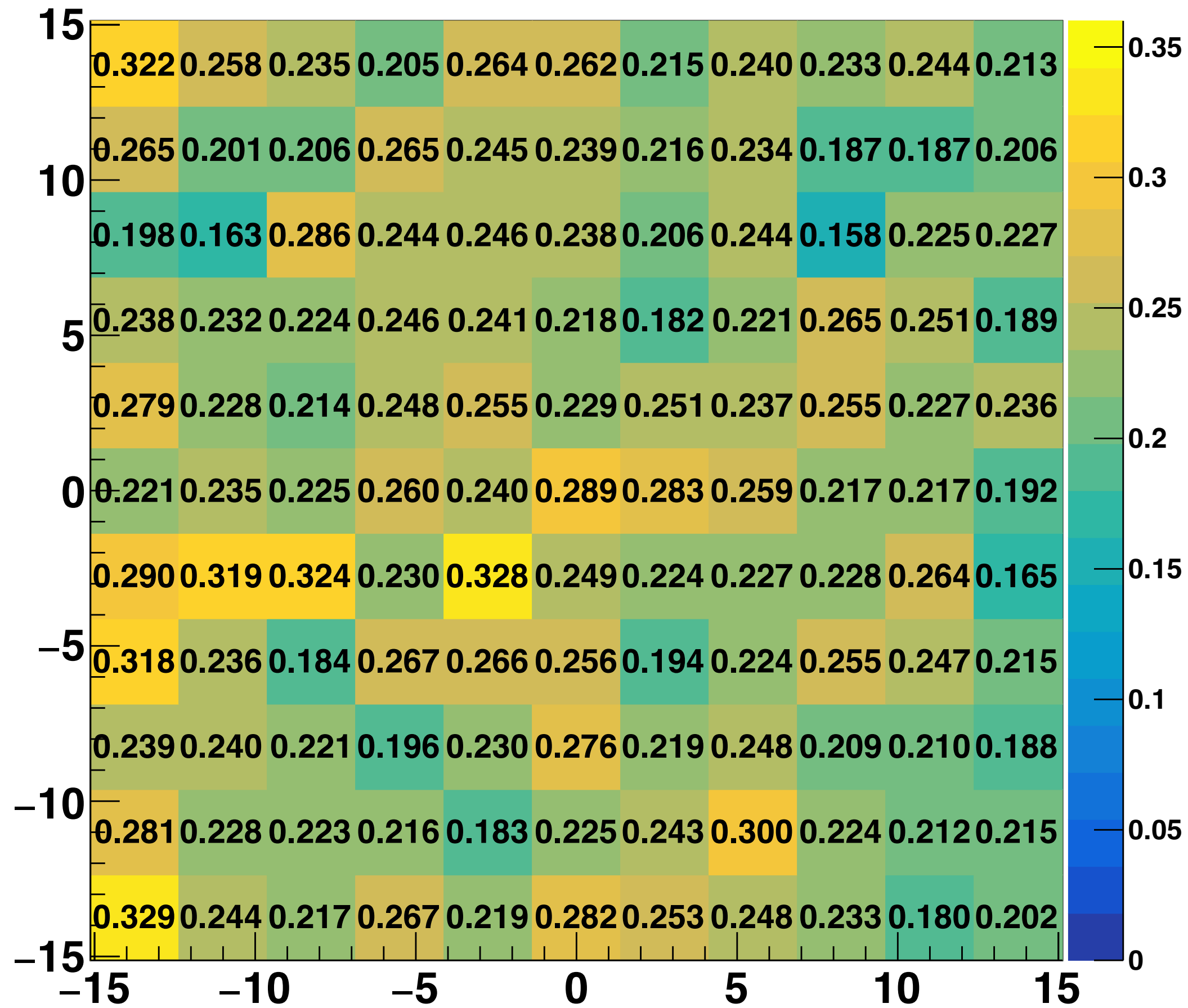

Factor non-uniformity - LG - Air - 4cm - base round - 11. mm

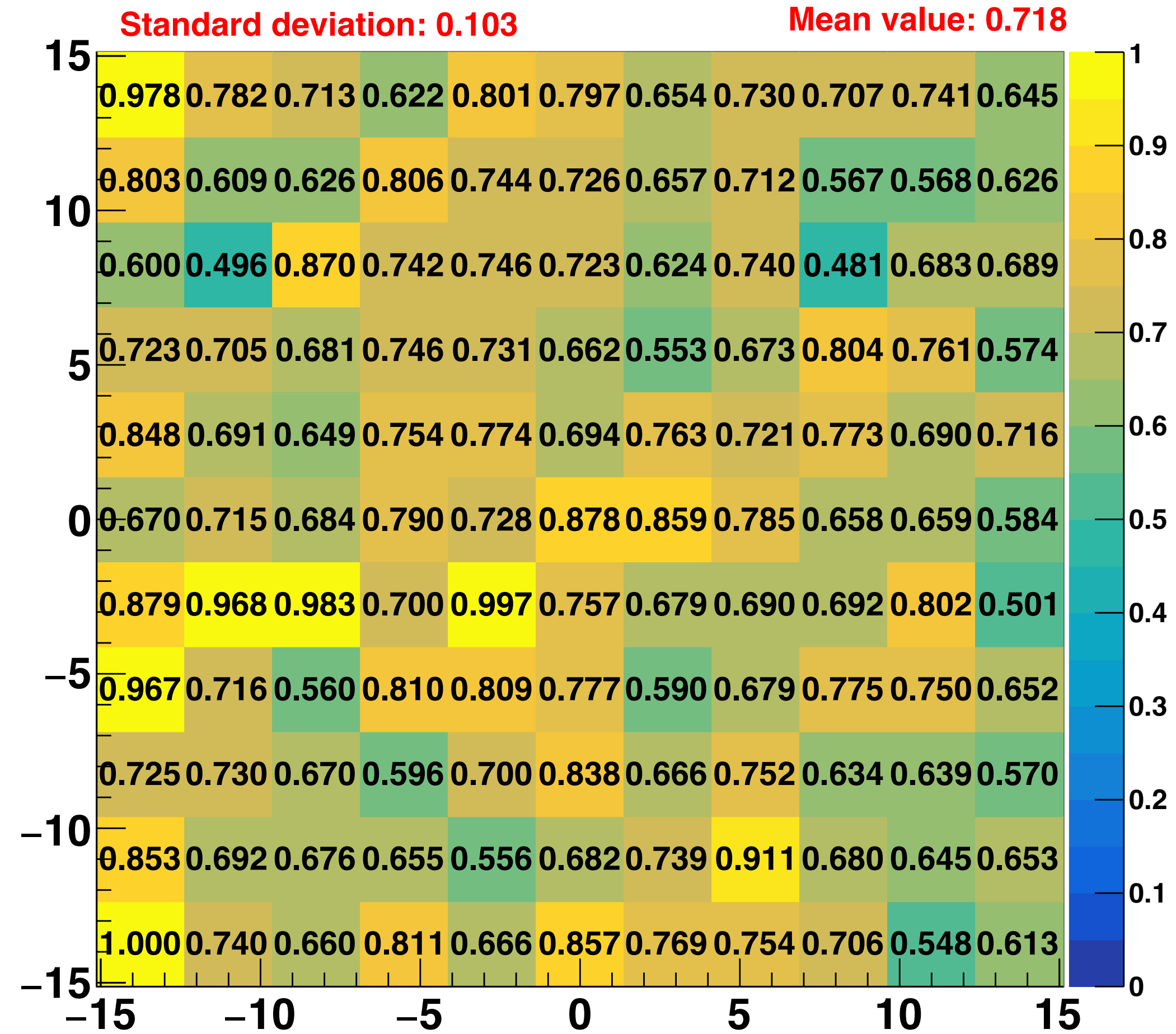

Geometry 4

AIR

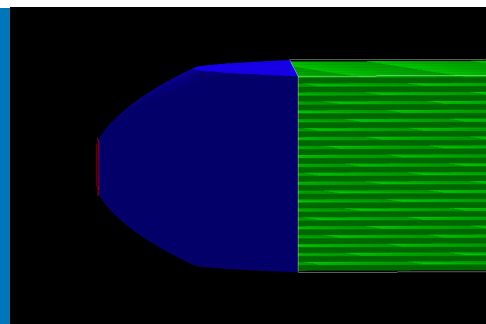

statistic 11.000 - muon 1 GeV

Winstone cone
PMT 11

Efficiency - LG - Air - 5cm - base round - 11. mm

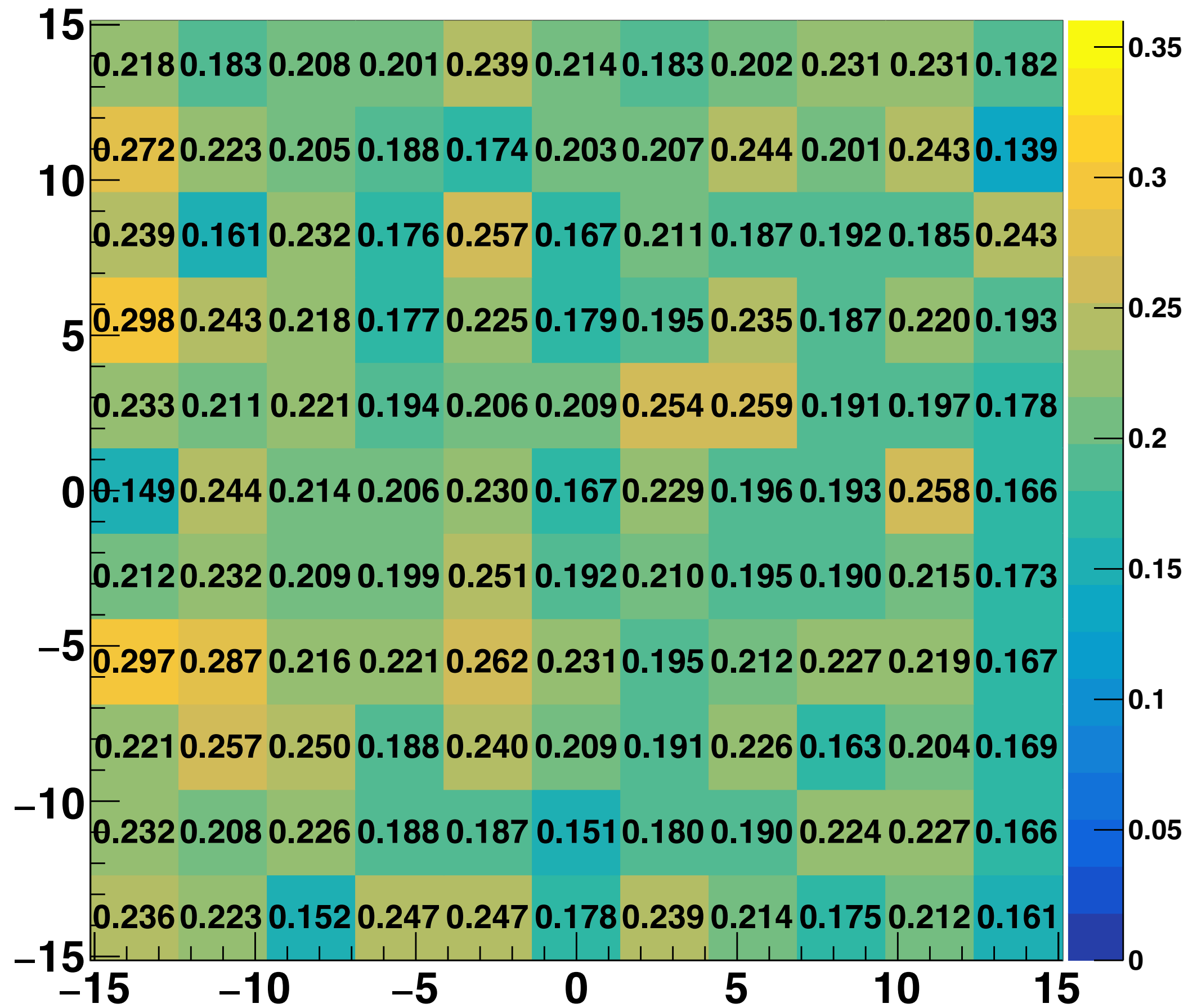

Factor non-uniformity - LG - Air - 5cm - base round - 11. mm

Standard deviation: 0.104

Mean value: 0.704

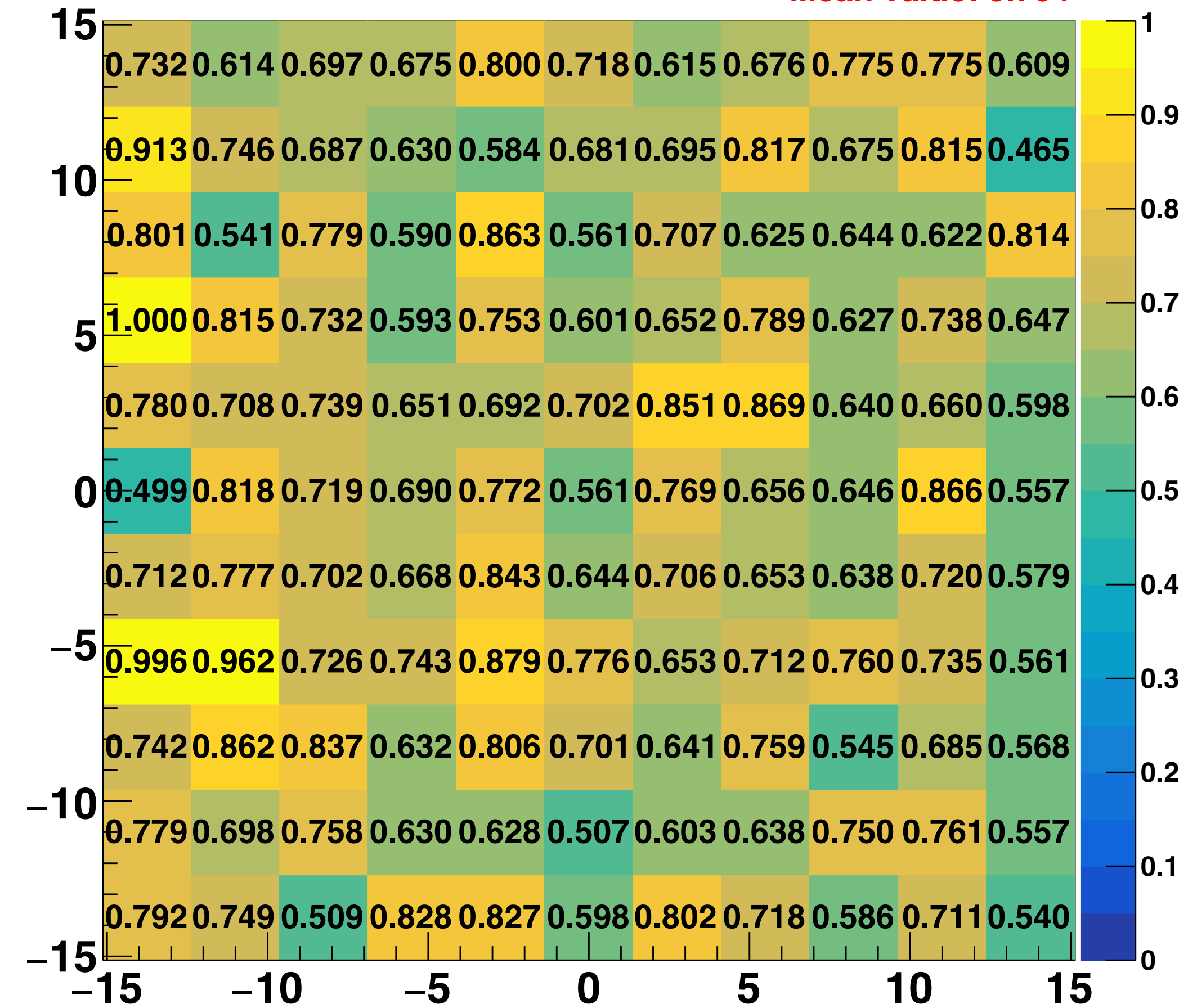

Geometry 4

AIR

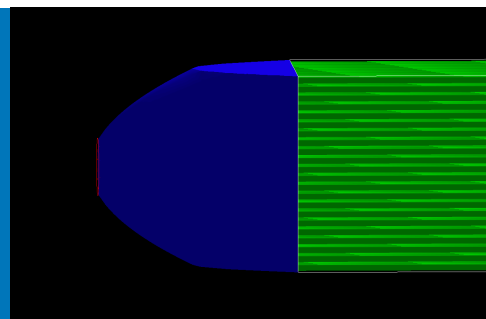

statistic 11.000 - muon 1 GeV

Winstone cone
PMT 11

Efficiency - LG - Air - 6cm - base round - 11. mm

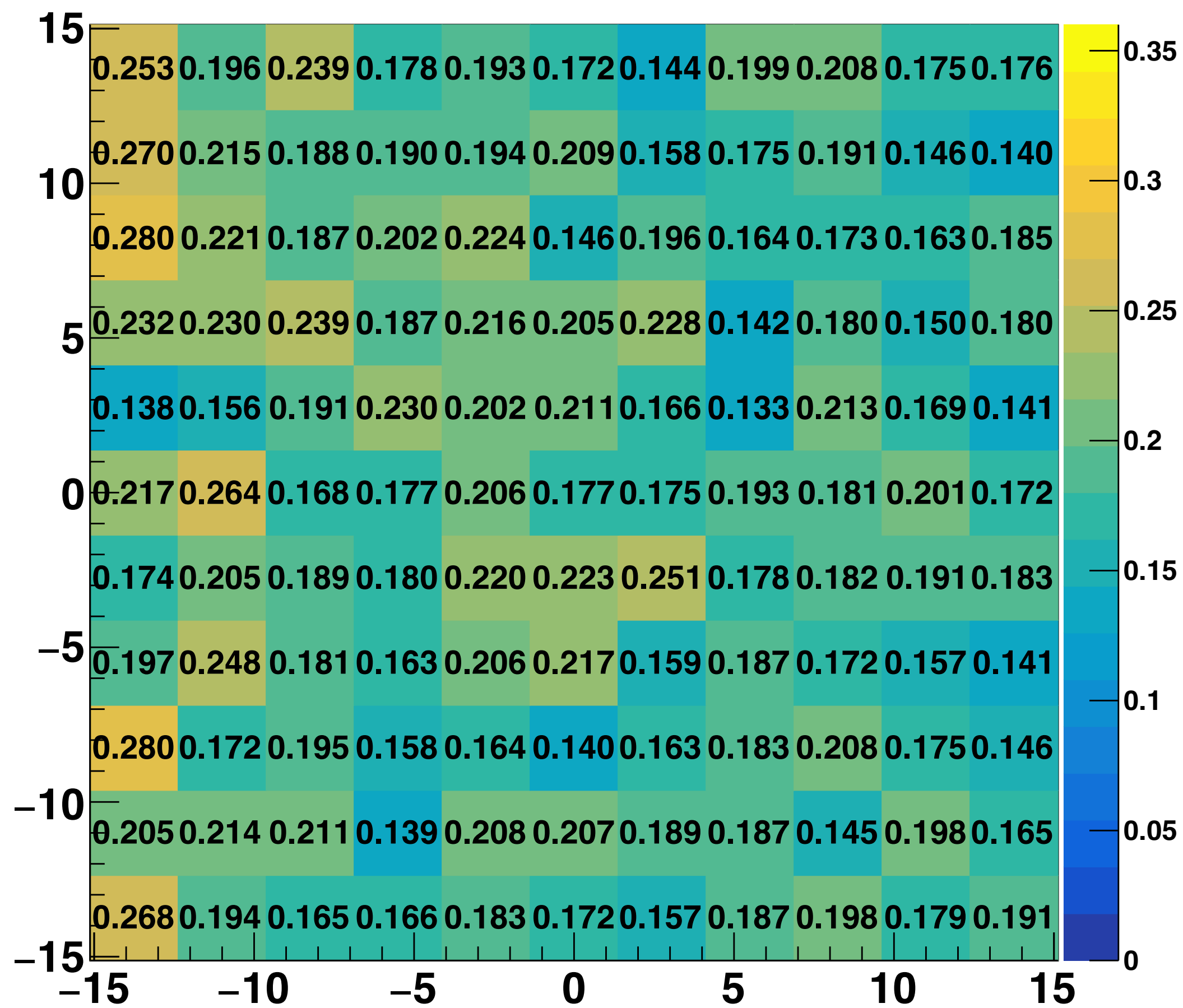

Factor non-uniformity - LG - Air - 6cm - base round - 11. mm

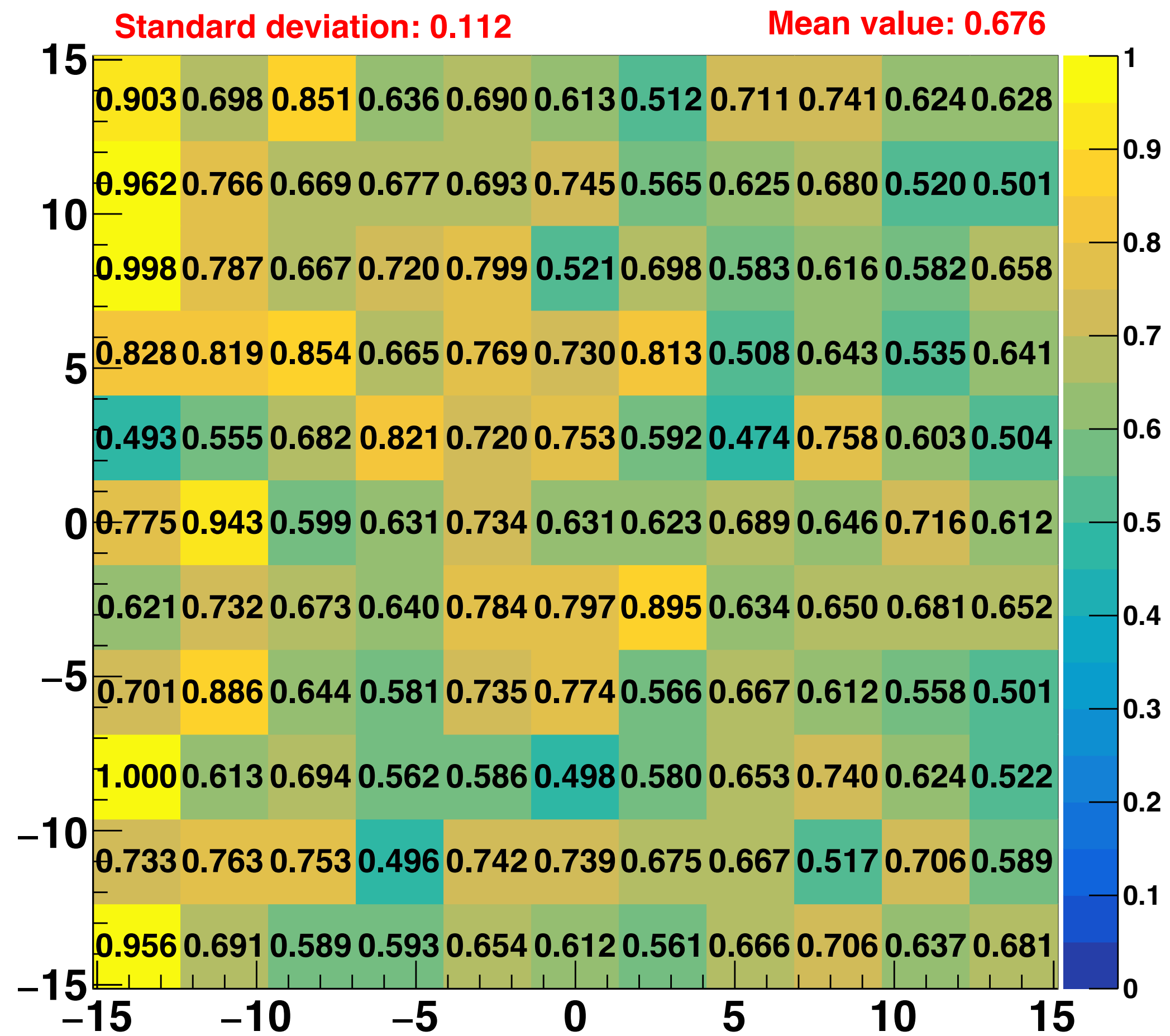

- **Geometry 5**

PMMA

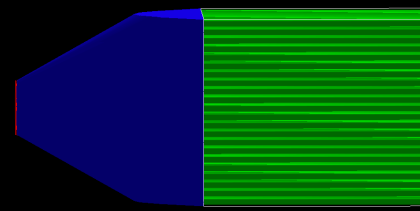

statistic 11.000 - muon 1 GeV

FISH TAIL
PMT 4.5

Geometry 5

PMMA

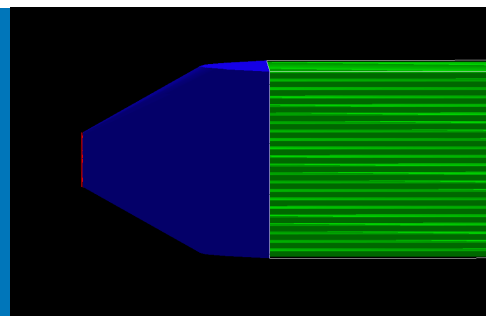

statistic 11.000 - muon 1 GeV

FISH TAIL
PMT 4.5

Efficiency - LG - PMMA - 2cm - base round - 4.5 mm

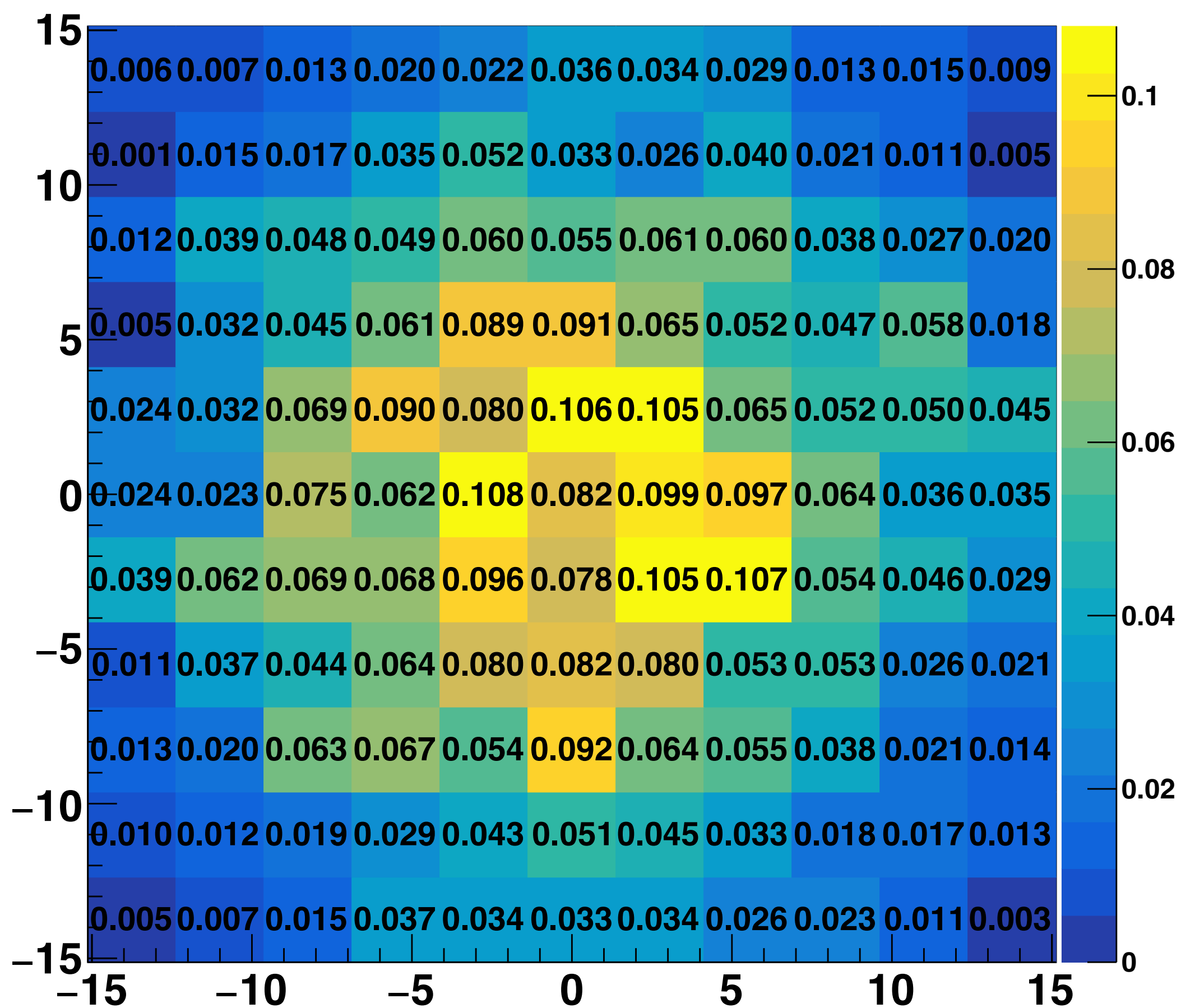

Factor non-uniformity - LG - PMMA - 2cm - base round - 4.5 mm

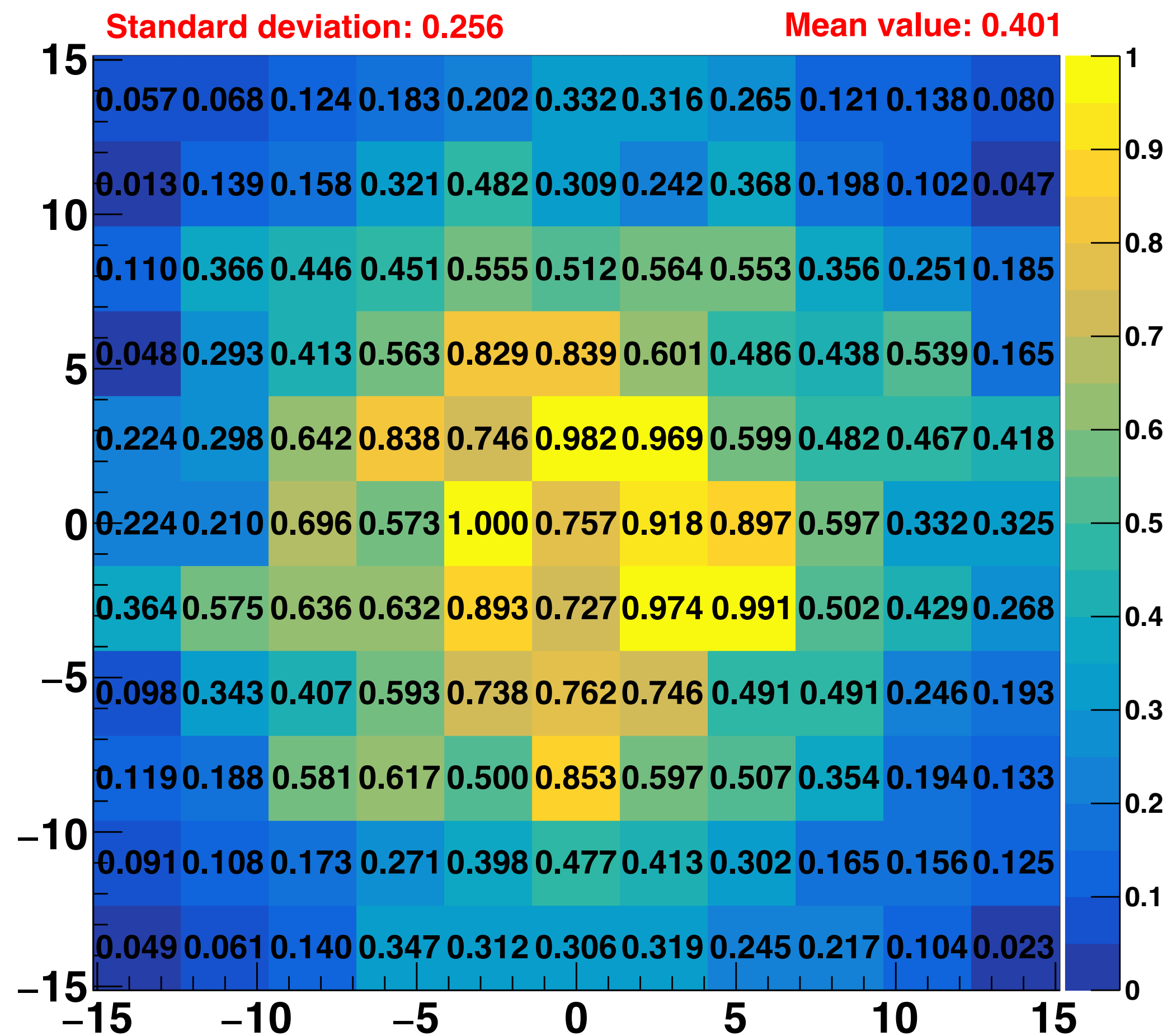

Geometry 5

PMMA

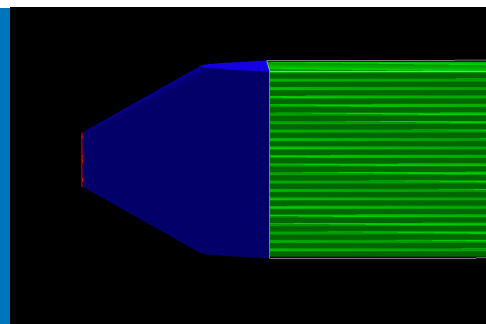

statistic 11.000 - muon 1 GeV

FISH TAIL
PMT 4.5

Efficiency - LG - PMMA - 3cm - base round - 4.5 mm

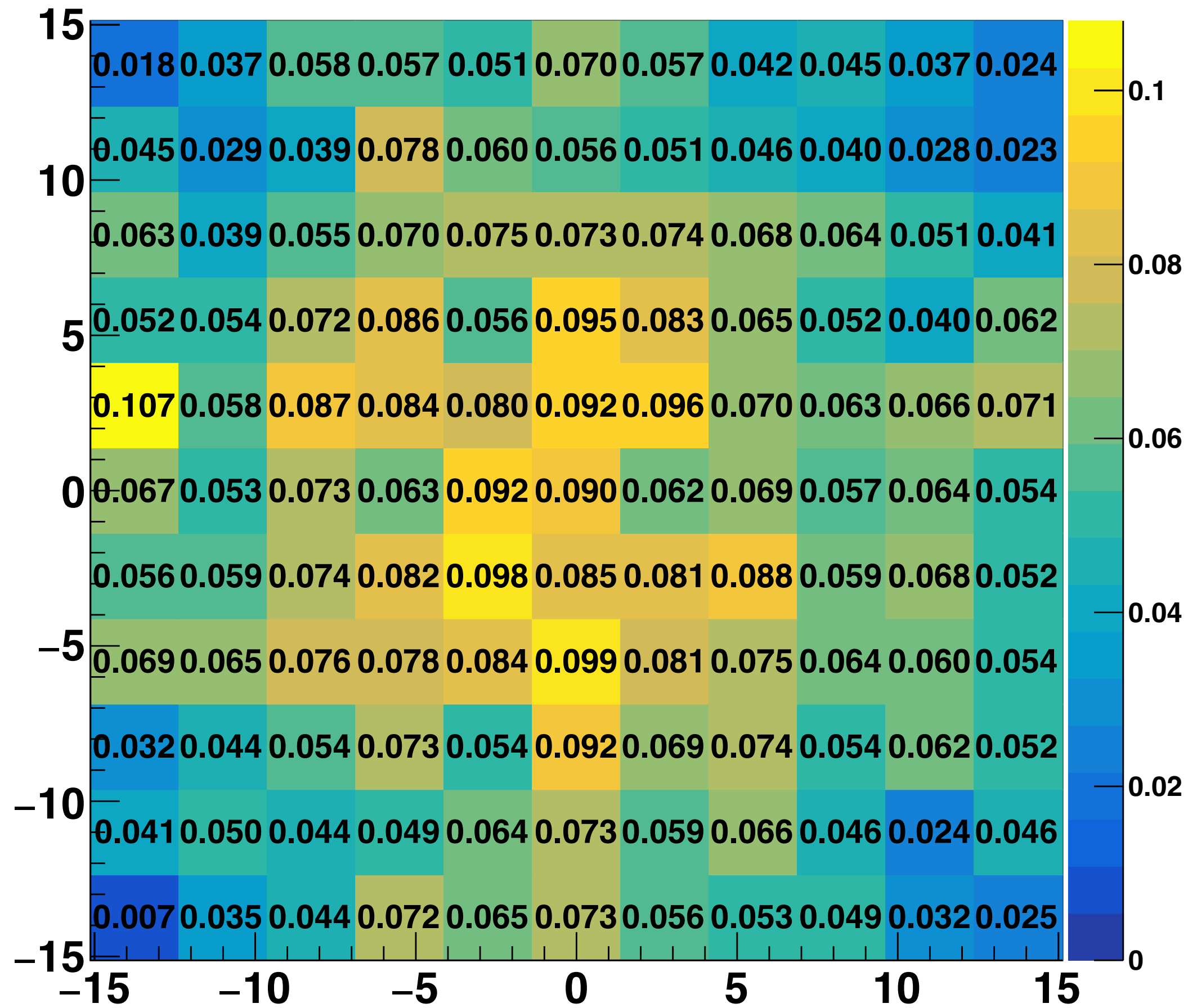

Factor non-uniformity - LG - PMMA - 3cm - base round - 4.5 mm

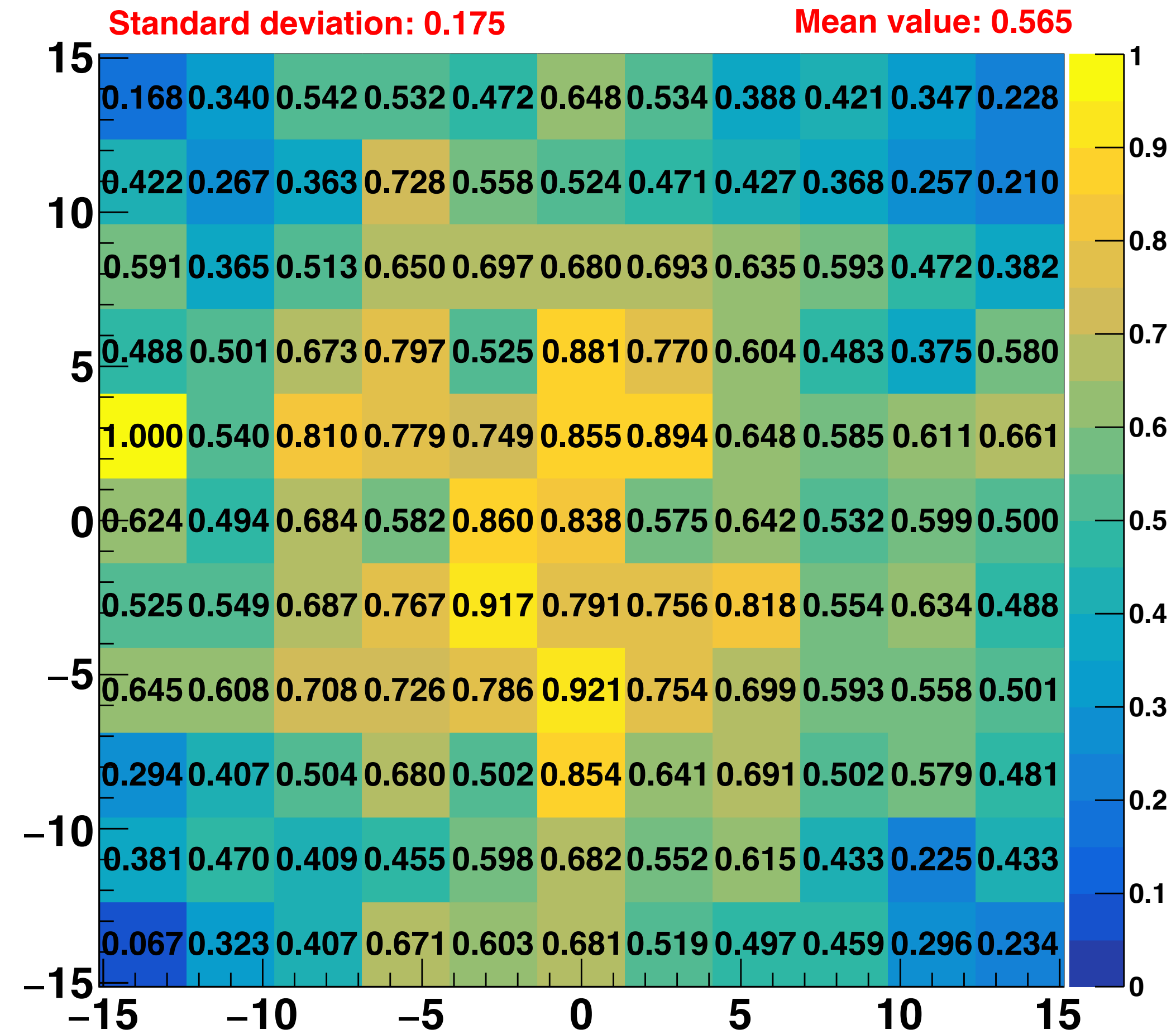

Geometry 5

PMMA

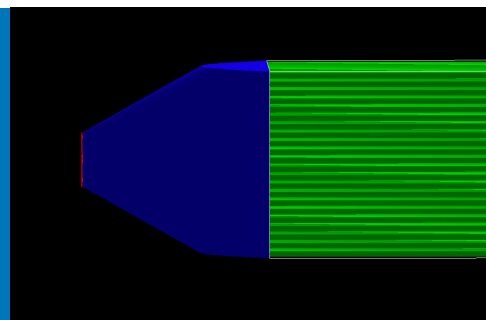

statistic 11.000 - muon 1 GeV

FISH TAIL
PMT 4.5

Efficiency - LG - PMMA - 4cm - base round - 4.5 mm

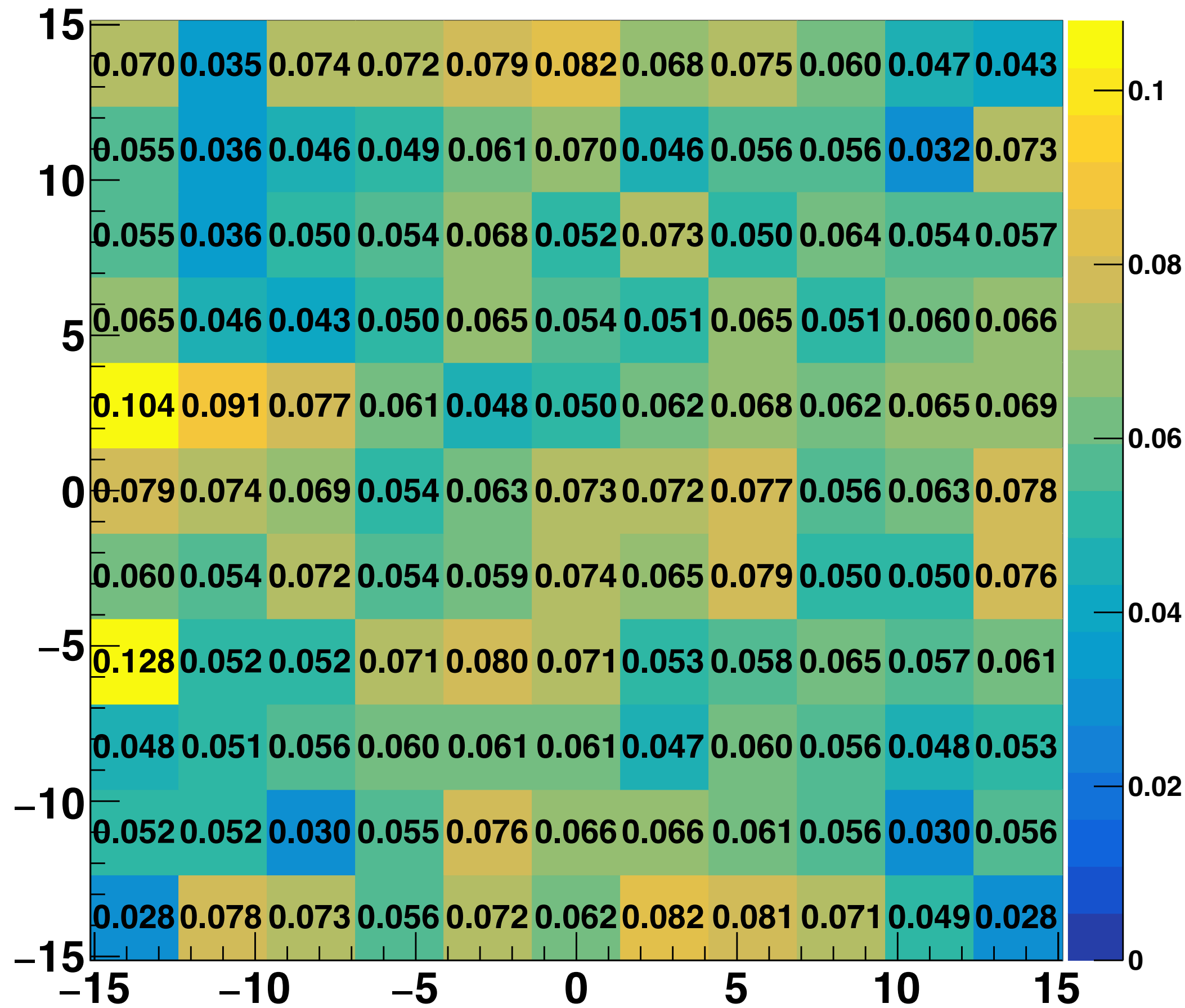

Factor non-uniformity - LG - PMMA - 4cm - base round - 4.5 mm

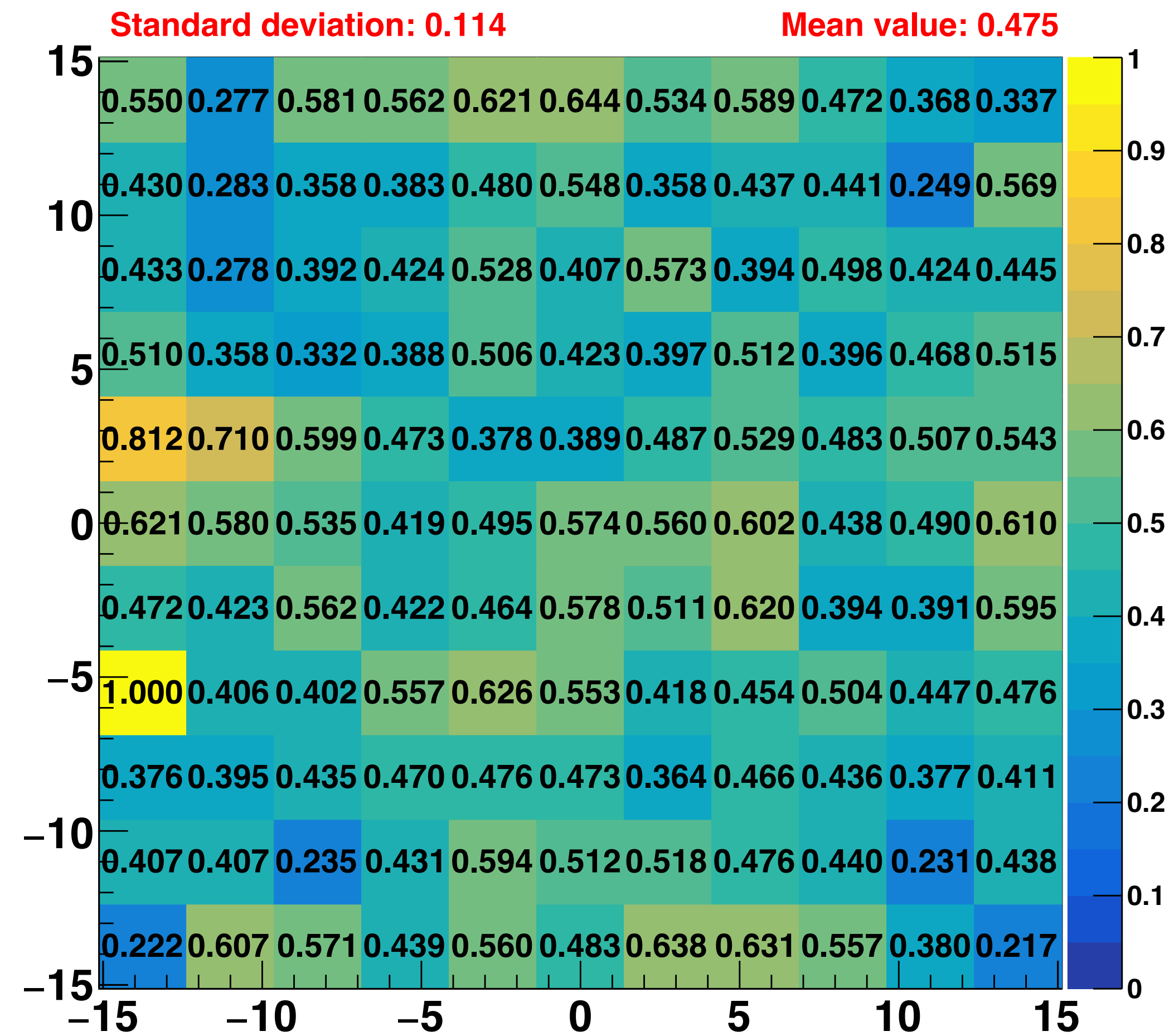

Geometry 5

PMMA

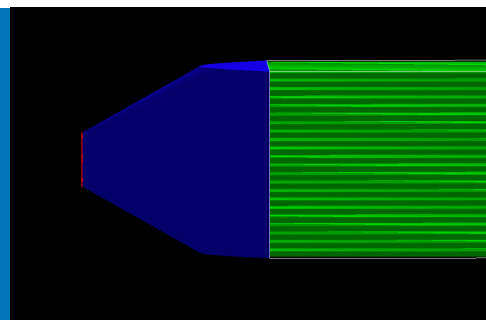

statistic 11.000 - muon 1 GeV

FISH TAIL
PMT 4.5

Efficiency - LG - PMMA - 5cm - base round - 4.5 mm

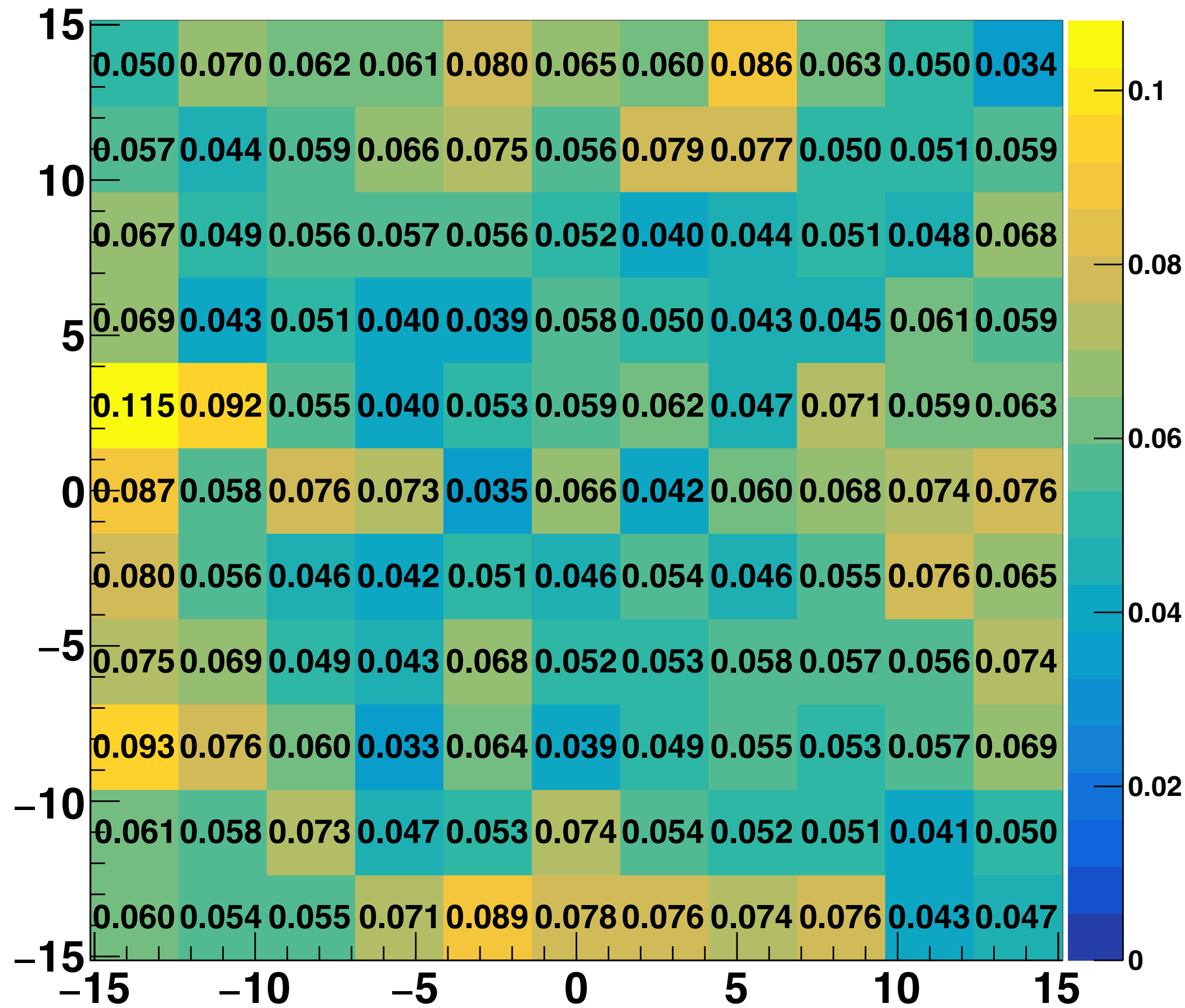

Factor non-uniformity - LG - PMMA - 5cm - base round - 4.5 mm

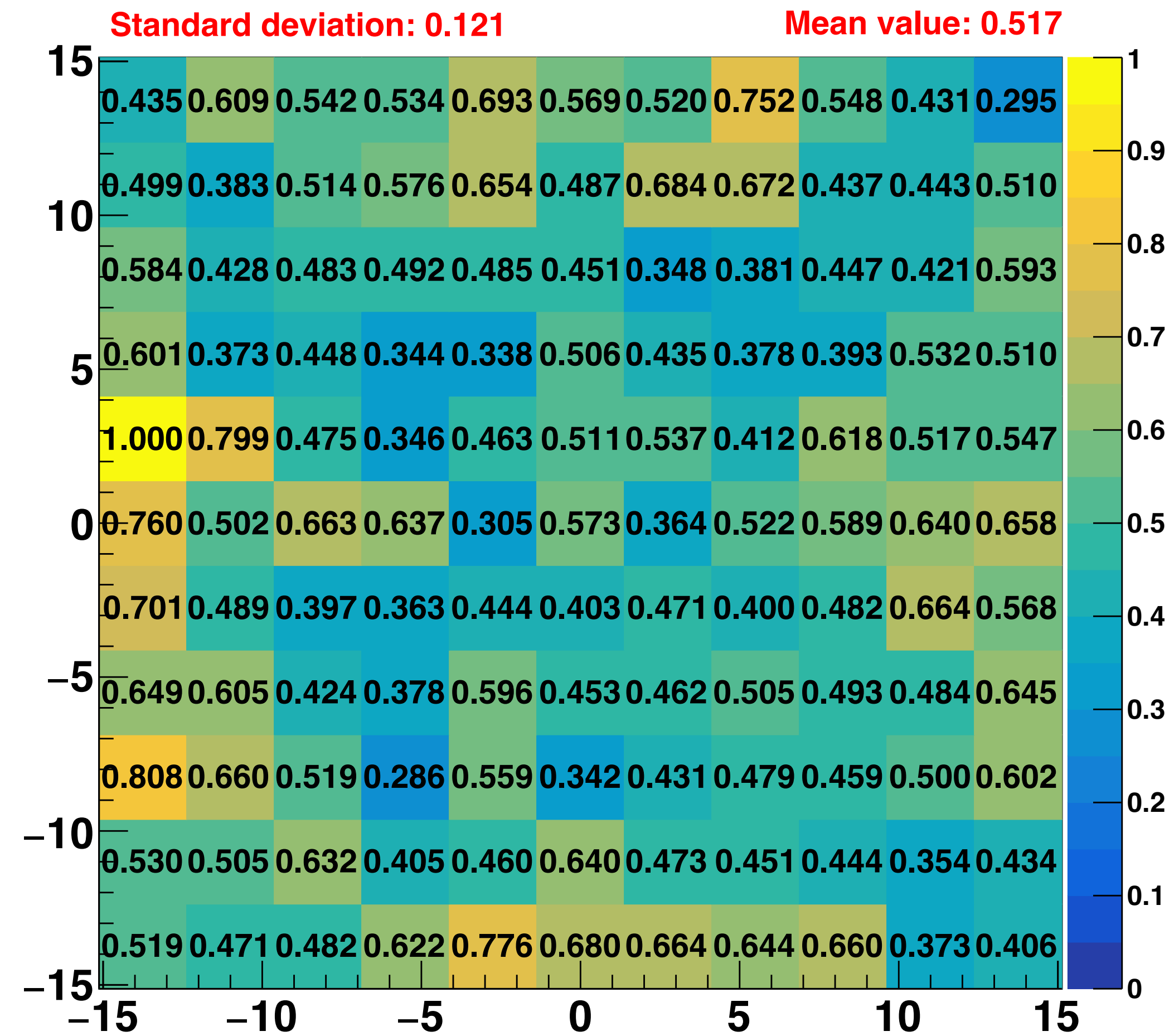

Geometry 5

PMMA

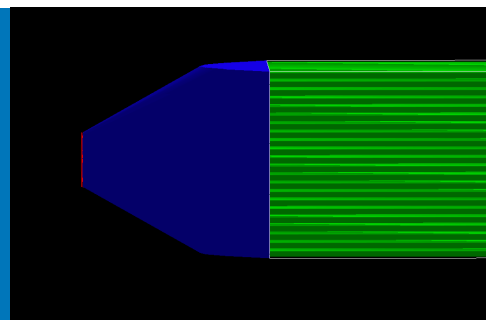

statistic 11.000 - muon 1 GeV

FISH TAIL
PMT 4.5

Efficiency - LG - PMMA - 6cm - base round - 4.5 mm

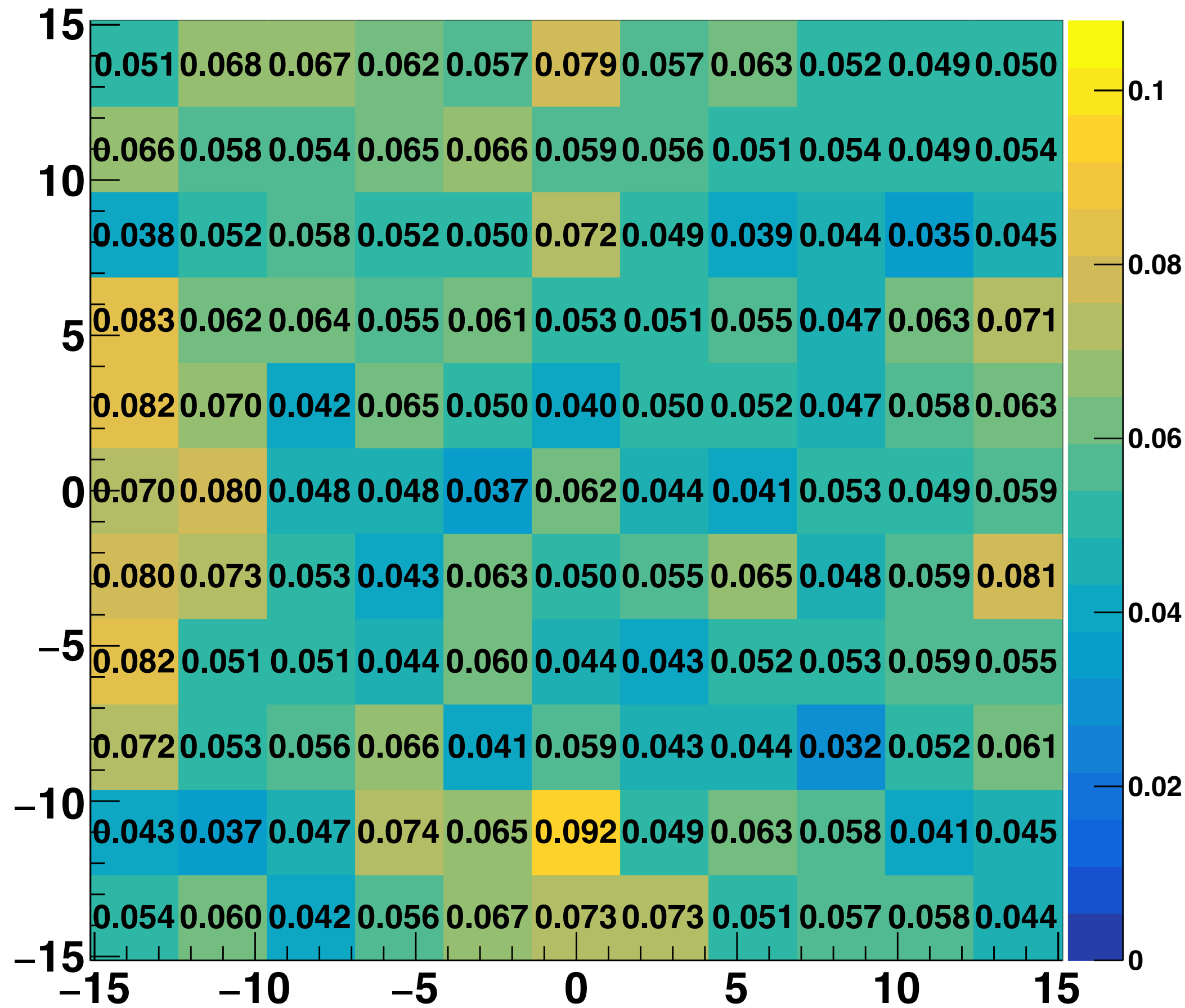

Factor non-uniformity - LG - PMMA - 6cm - base round - 4.5 mm

Standard deviation: 0.126

Mean value: 0.611

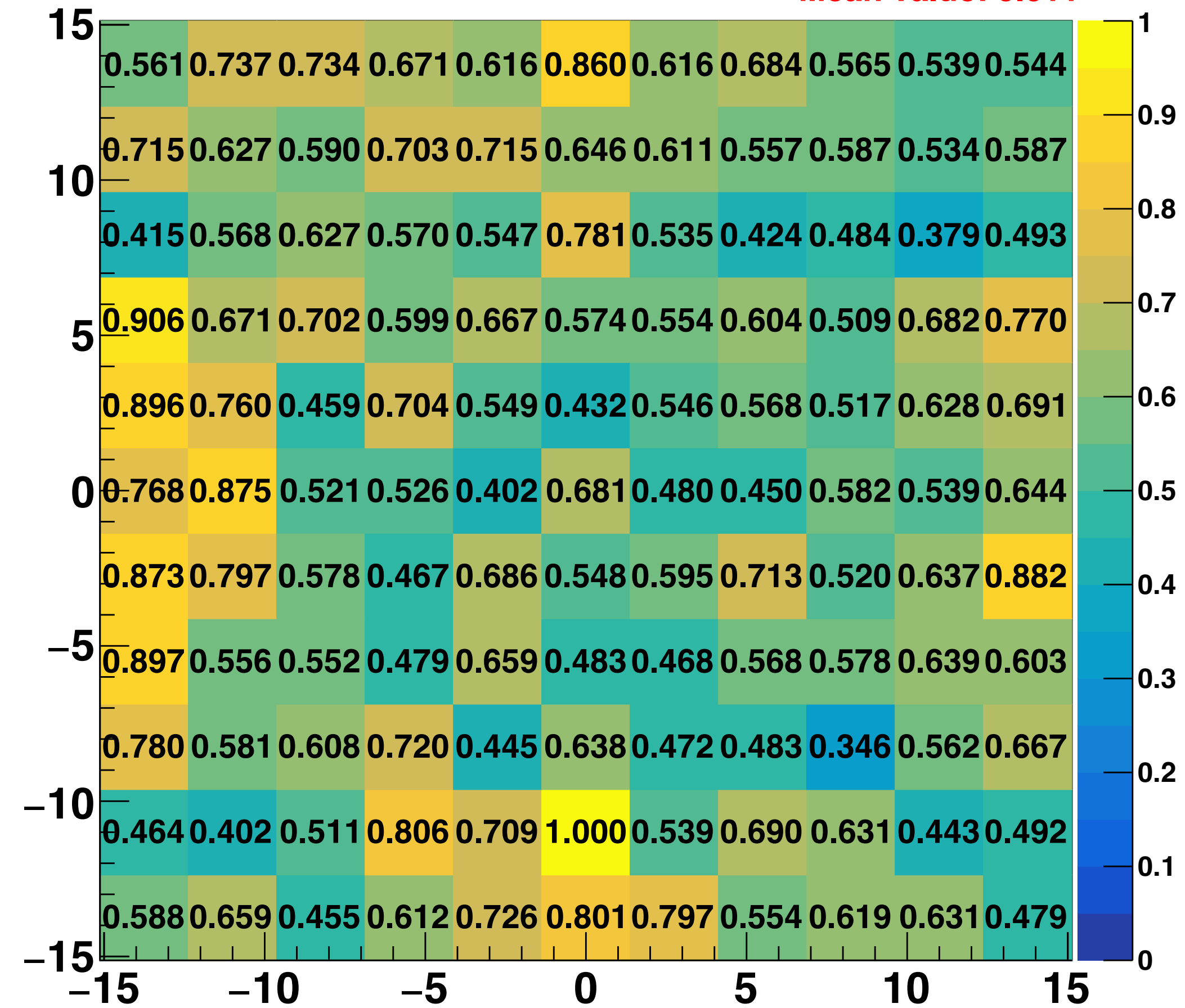

Geometry 5

AIR

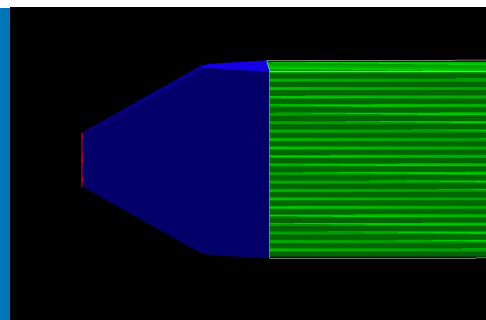

statistic 11.000 - muon 1 GeV

FISH TAIL
PMT 4.5

Efficiency - LG - Air - 2cm - base round - 4.5 mm

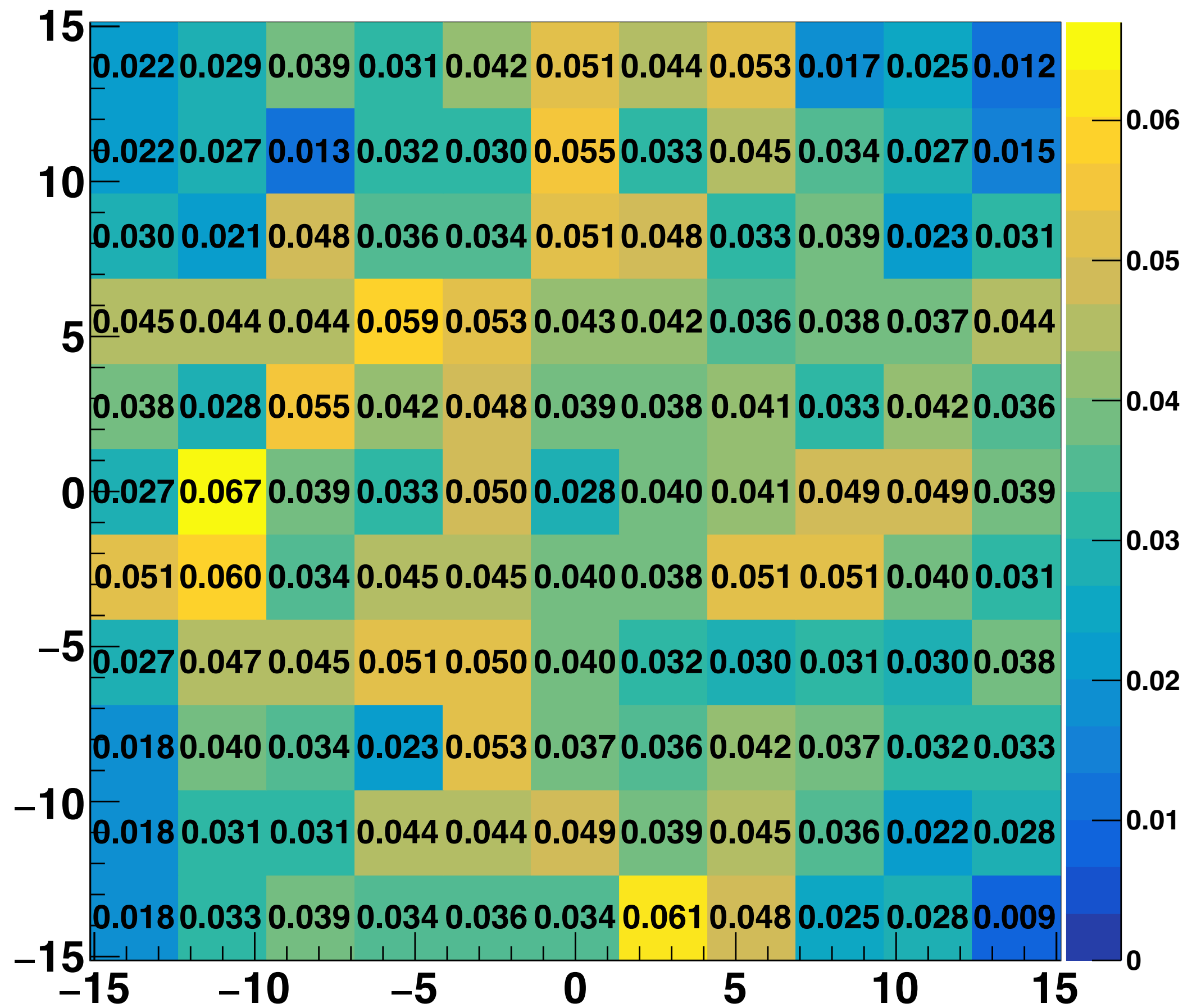

Factor non-uniformity - LG - Air - 2cm - base round - 4.5 mm

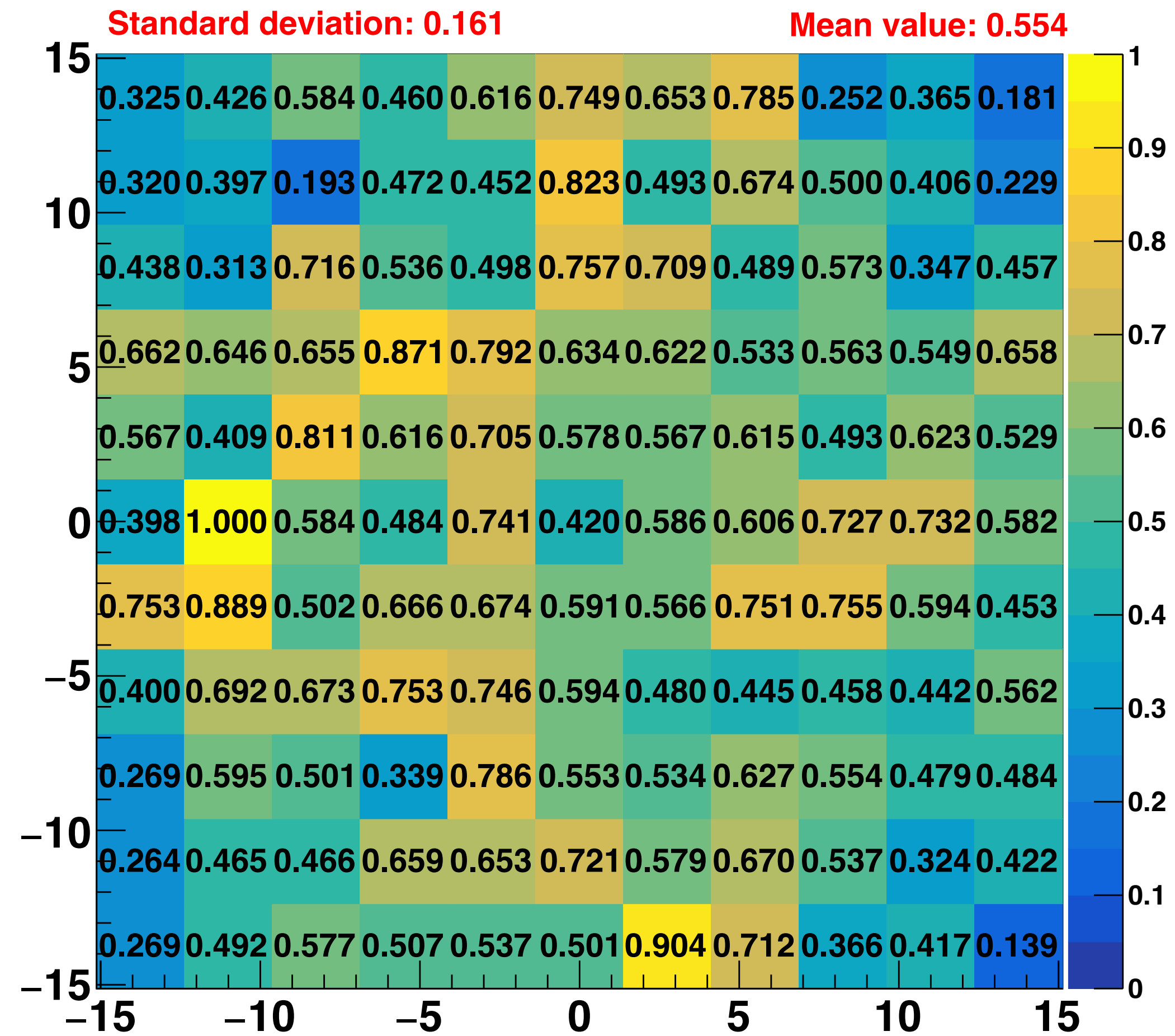

Geometry 5

AIR

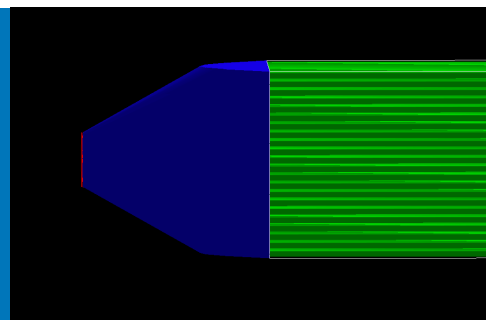

statistic 11.000 - muon 1 GeV

FISH TAIL
PMT 4.5

Efficiency - LG - Air - 3cm - base round - 4.5 mm

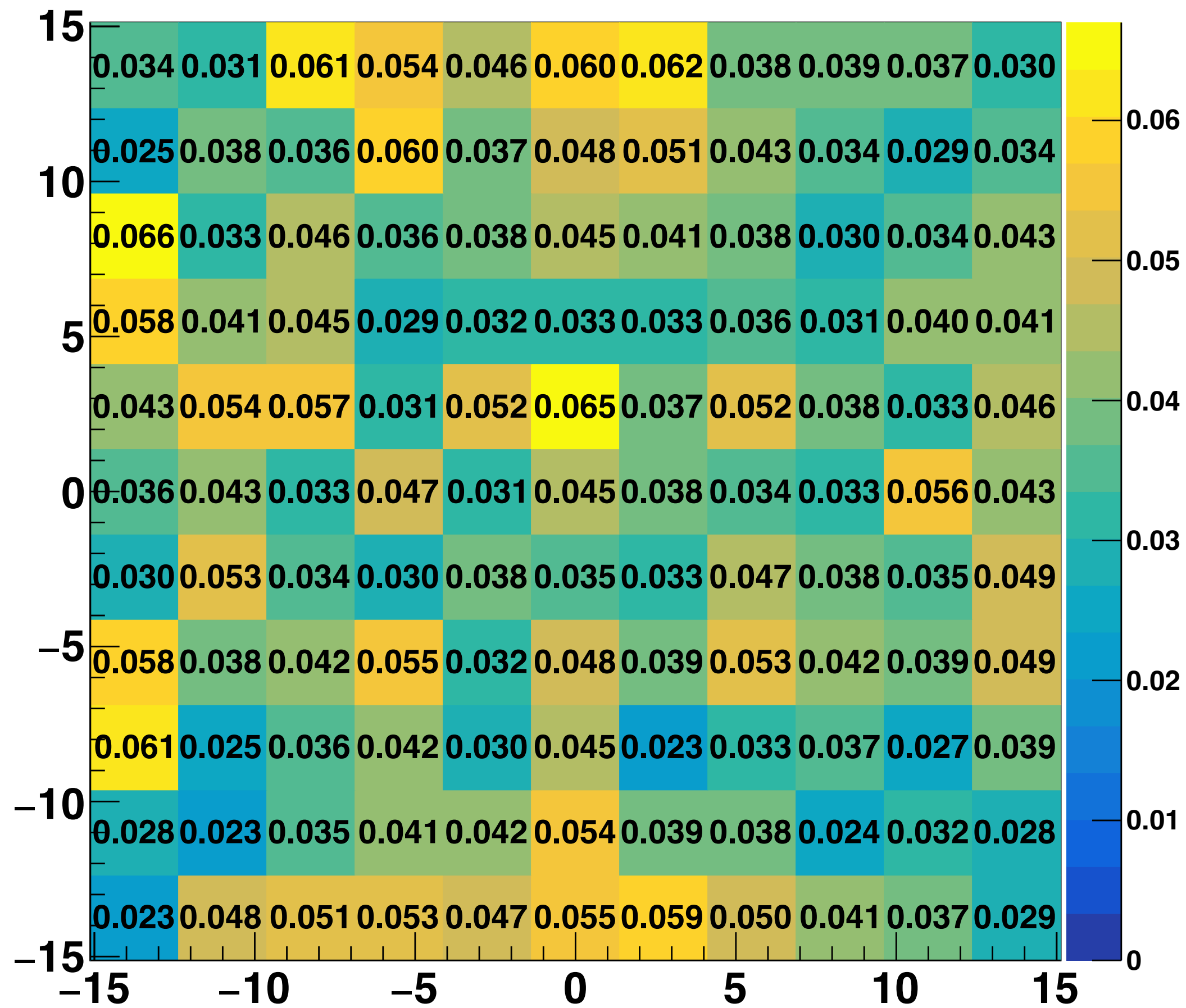

Factor non-uniformity - LG - Air - 3cm - base round - 4.5 mm

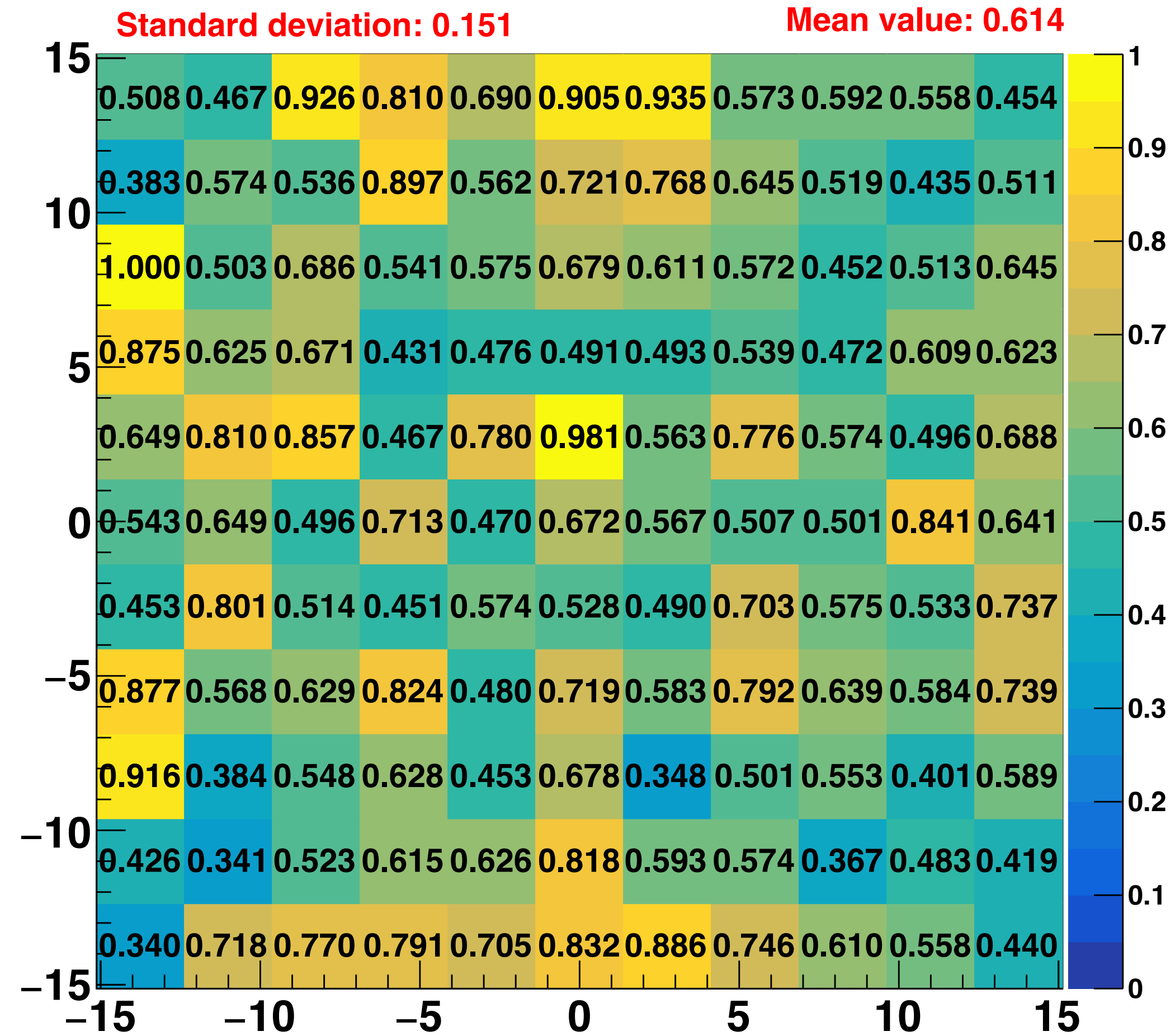

• Geometry 5

AIR

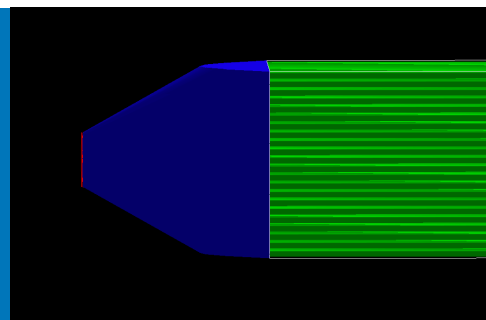

statistic 11.000 - muon 1 GeV

FISH TAIL
PMT 4.5

Efficiency - LG - Air - 4cm - base round - 4.5 mm

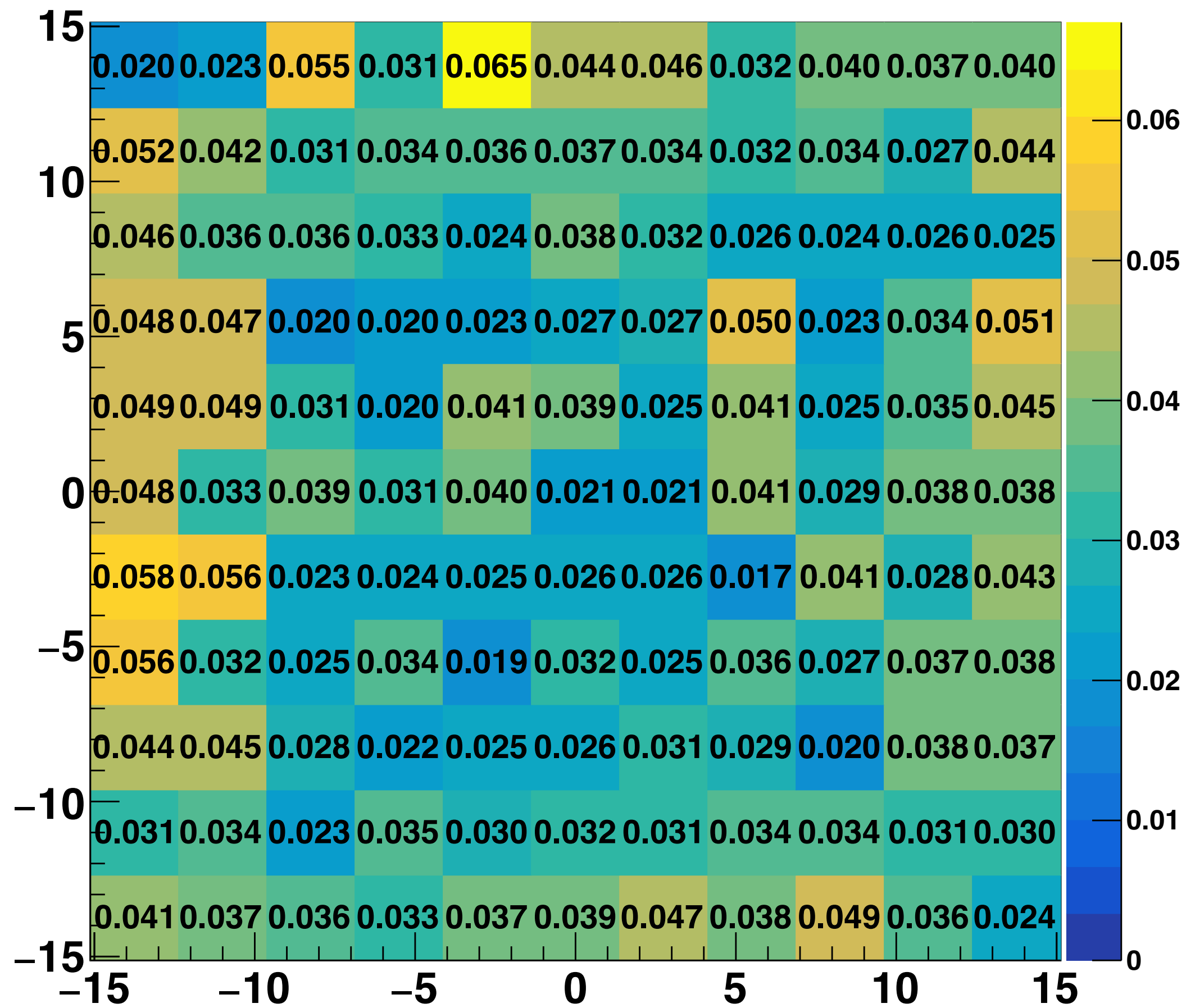

Factor non-uniformity - LG - Air - 4cm - base round - 4.5 mm

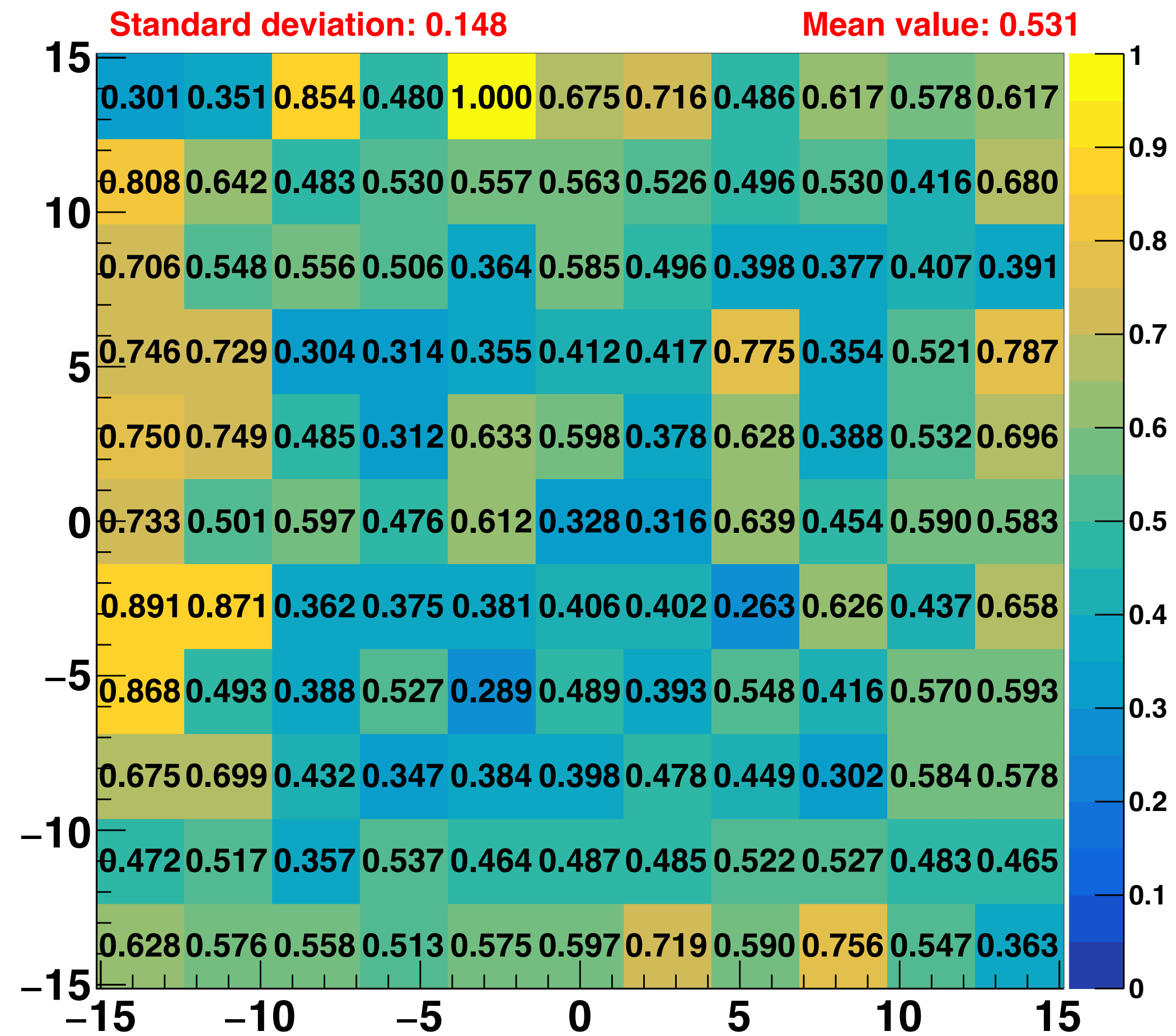

Geometry 5

AIR

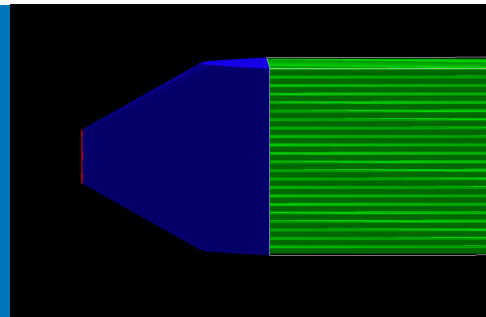

statistic 11.000 - muon 1 GeV

FISH TAIL
PMT 4.5

Efficiency - LG - Air - 5cm - base round - 4.5 mm

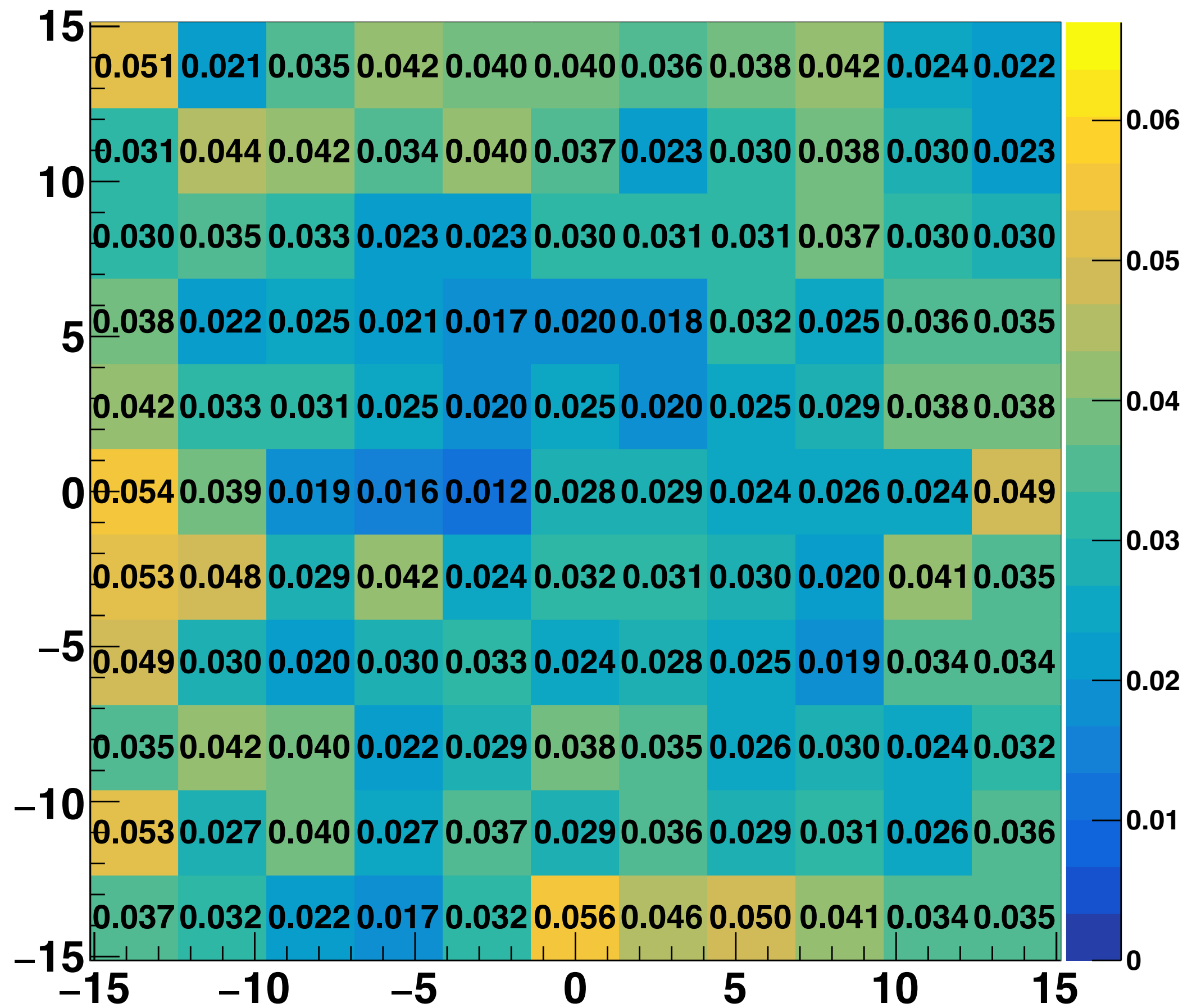

Factor non-uniformity - LG - Air - 5cm - base round - 4.5 mm

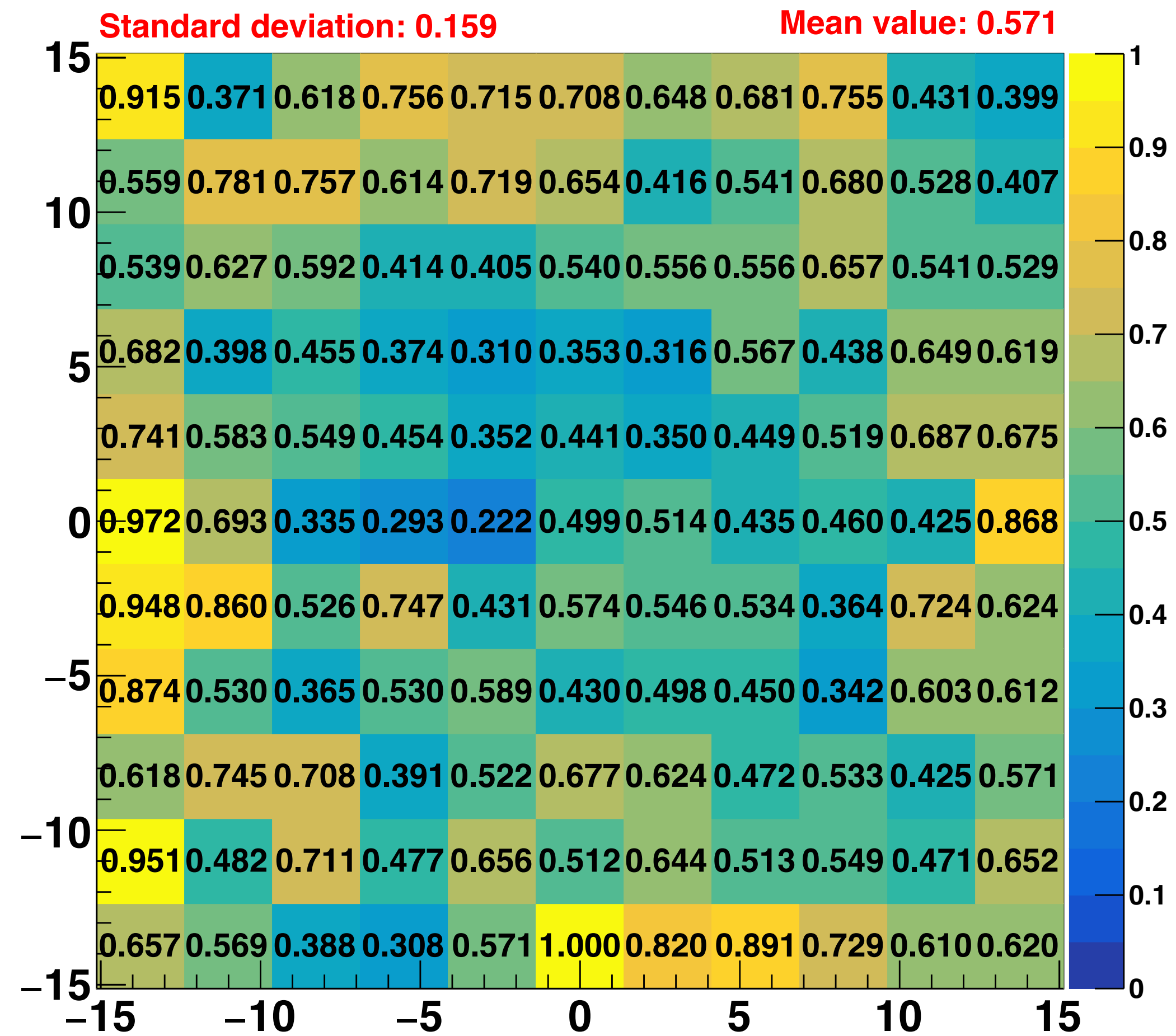

• Geometry 5

AIR

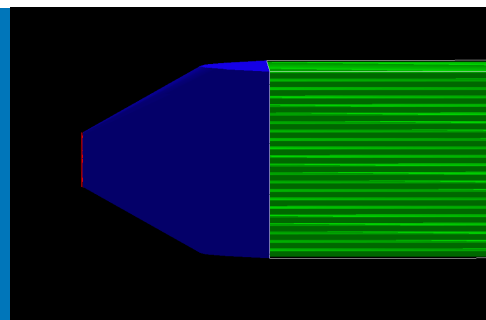

statistic 11.000 - muon 1 GeV

FISH TAIL
PMT 4.5

Efficiency - LG - Air - 6cm - base round - 4.5 mm

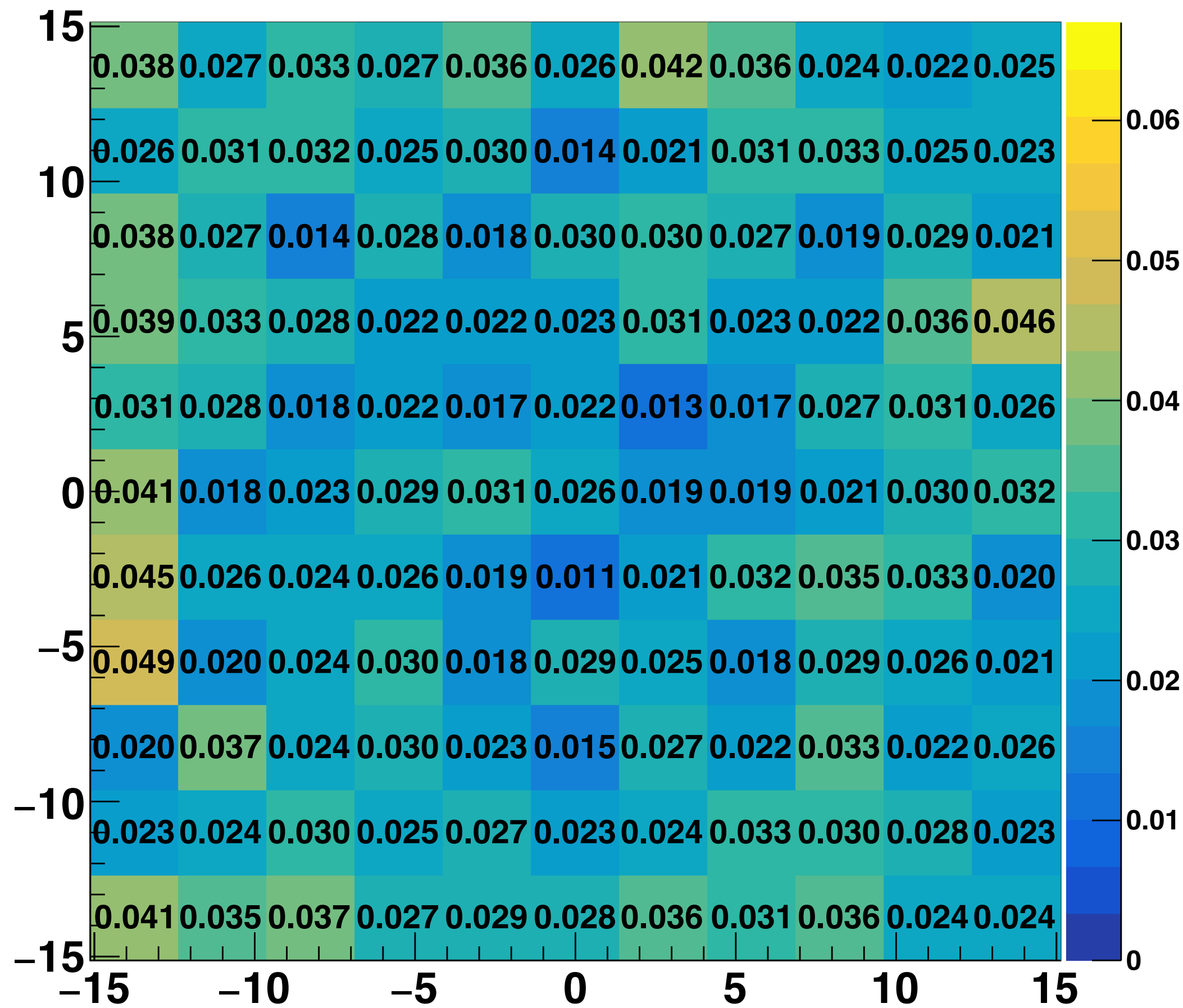

Factor non-uniformity - LG - Air - 6cm - base round - 4.5 mm

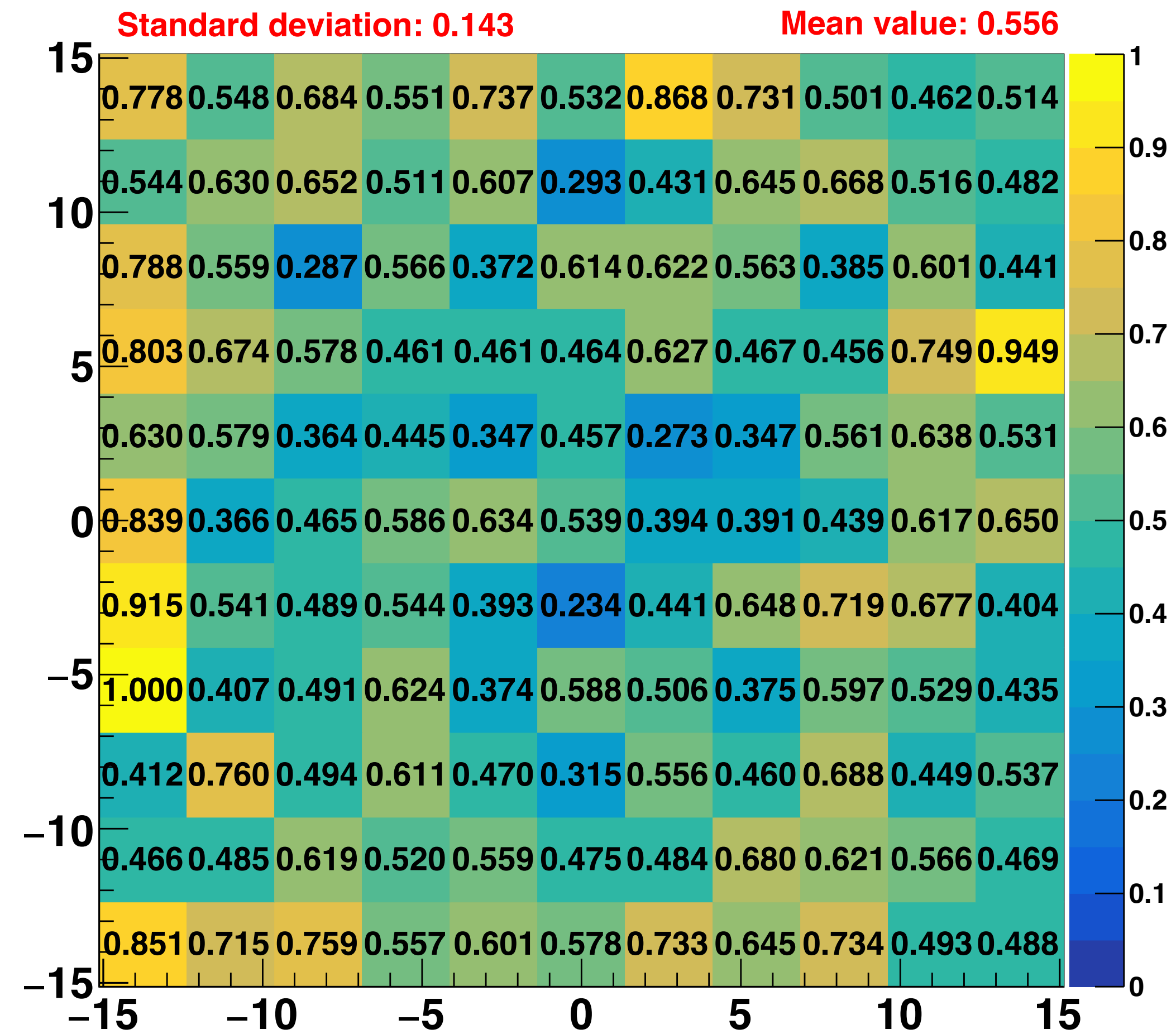

Geometry 5 -- PMMA - FT

Graph

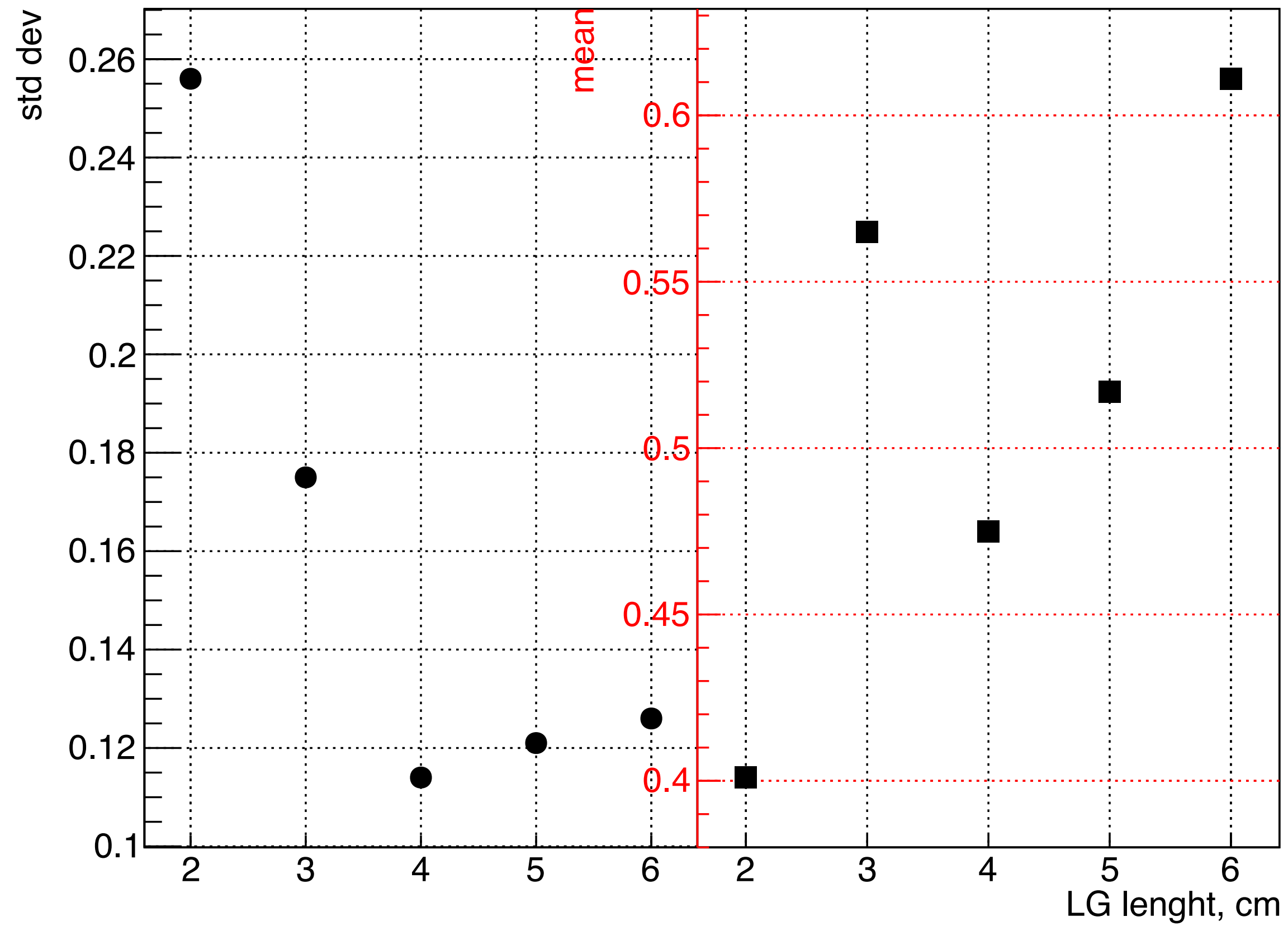

Geometry 5 -- AIR - FT

Graph

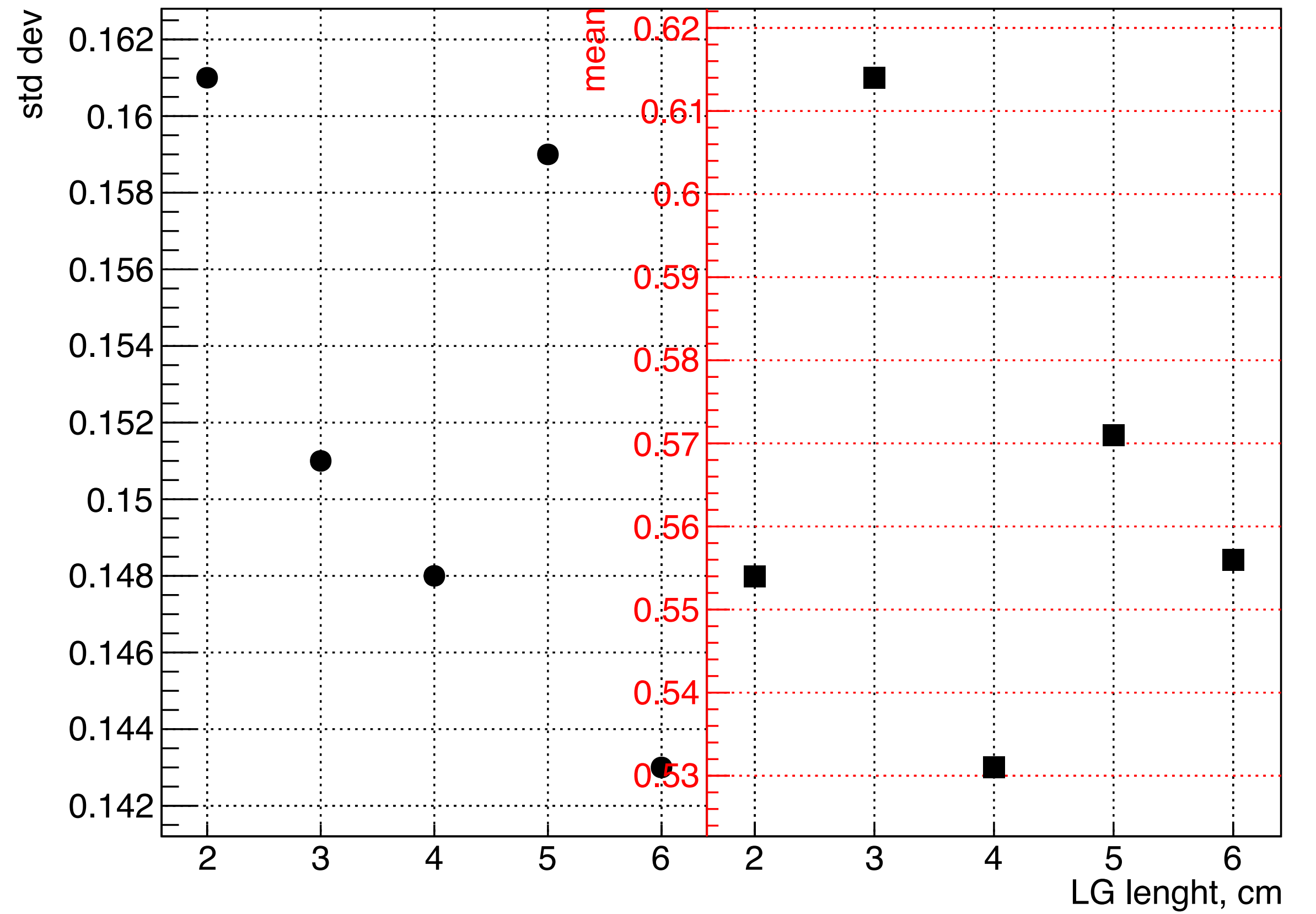

- **Geometry 6**

PMMA

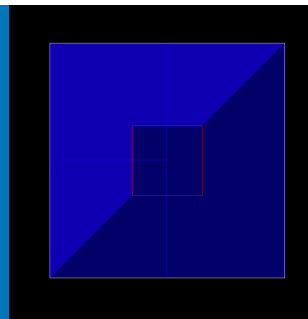

22x22 – Trap – 18 mm

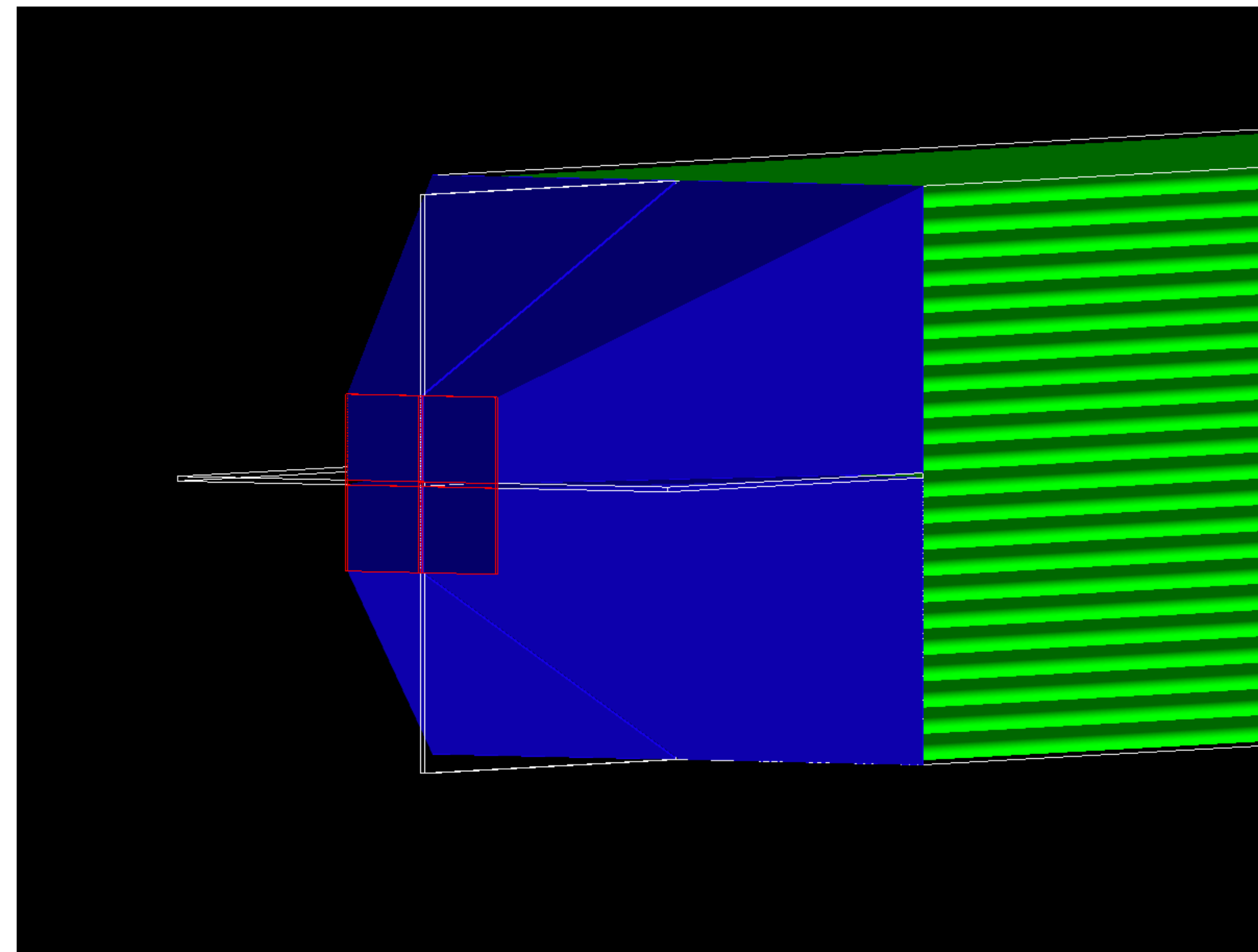
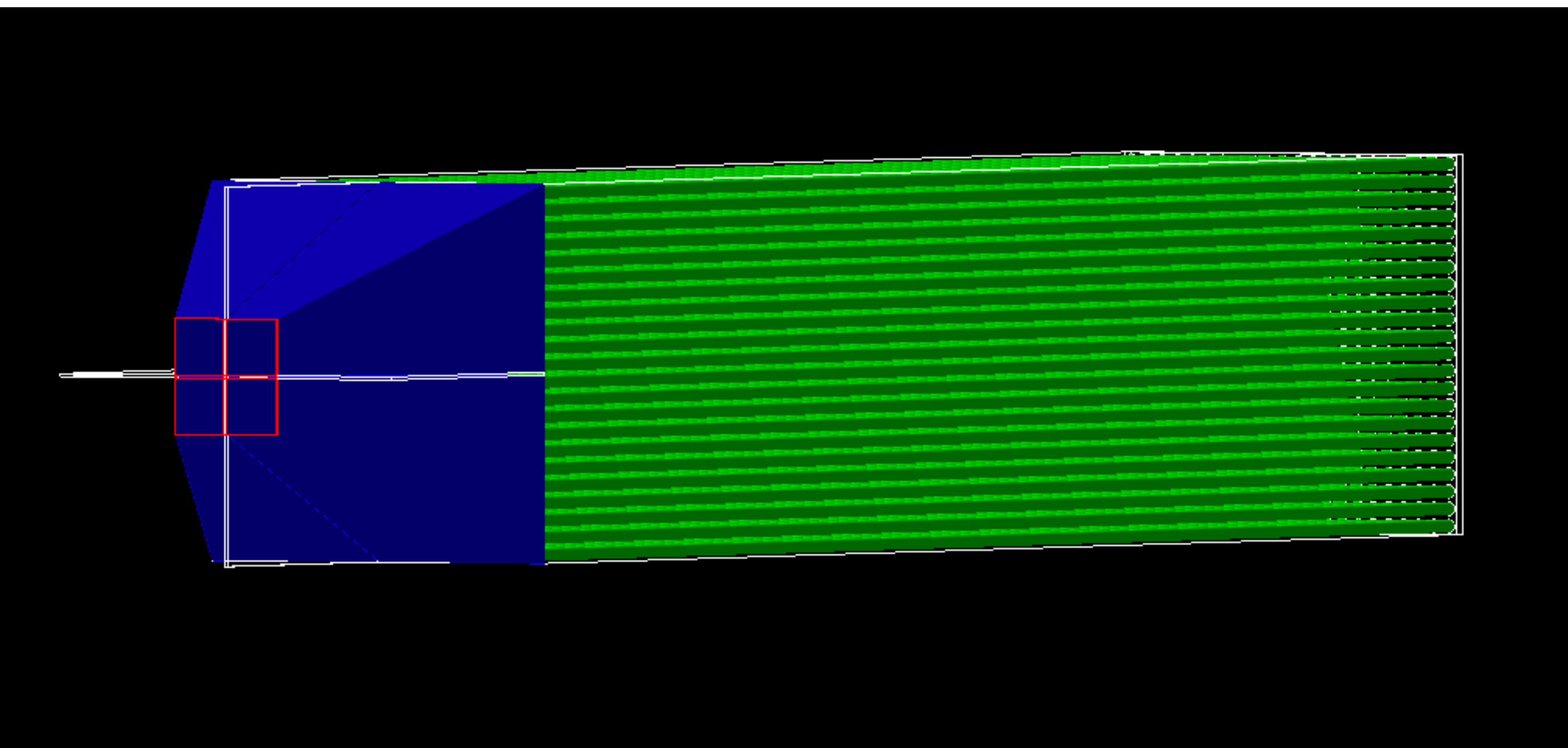
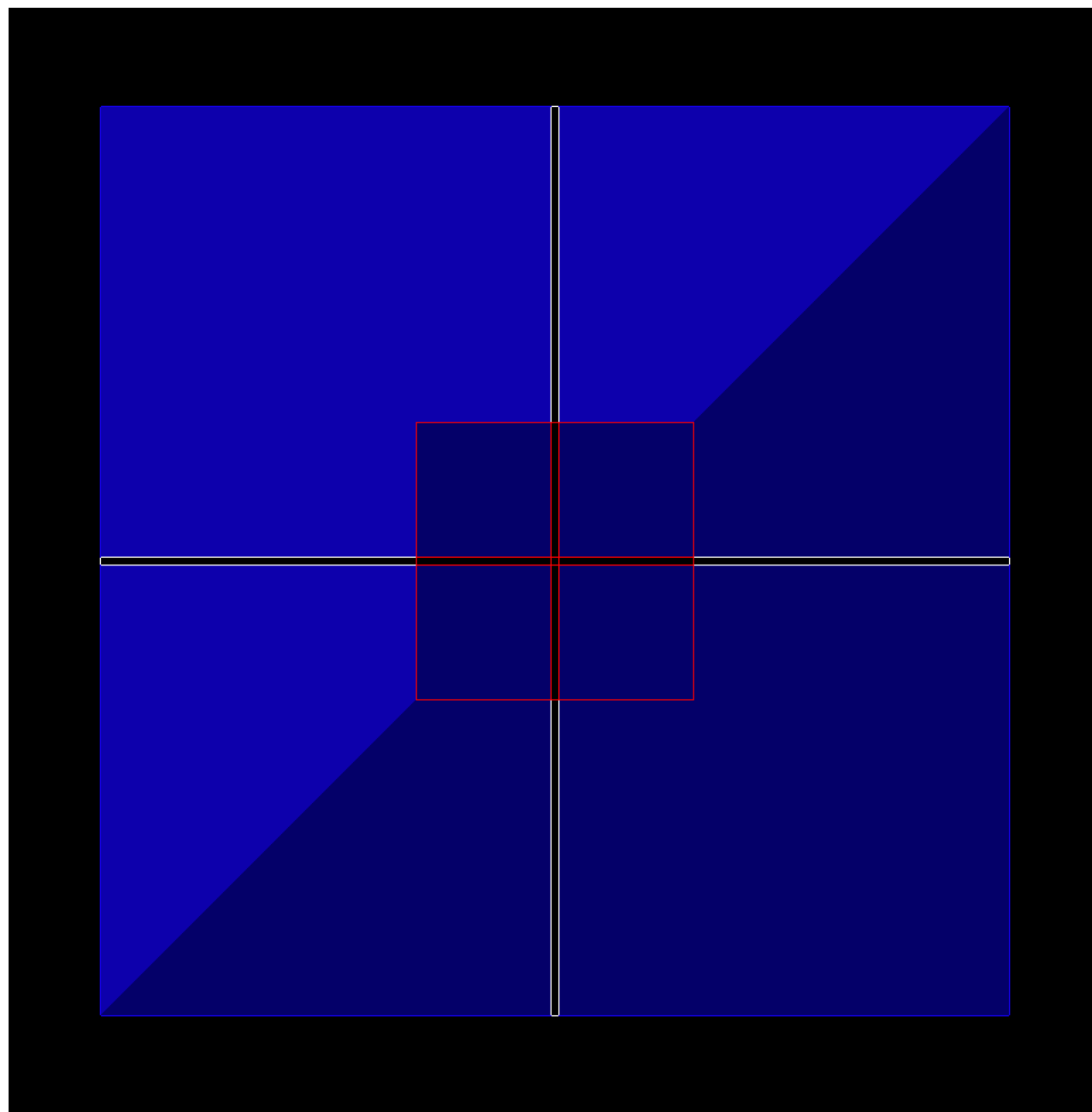

Geometry 6

PMMA

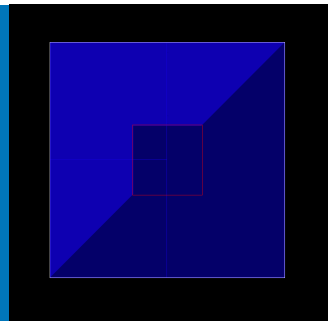

22x22 – Trap – 18 mm

Efficiency - LG - PMMA - 2cm - 22x22 - 18. mm

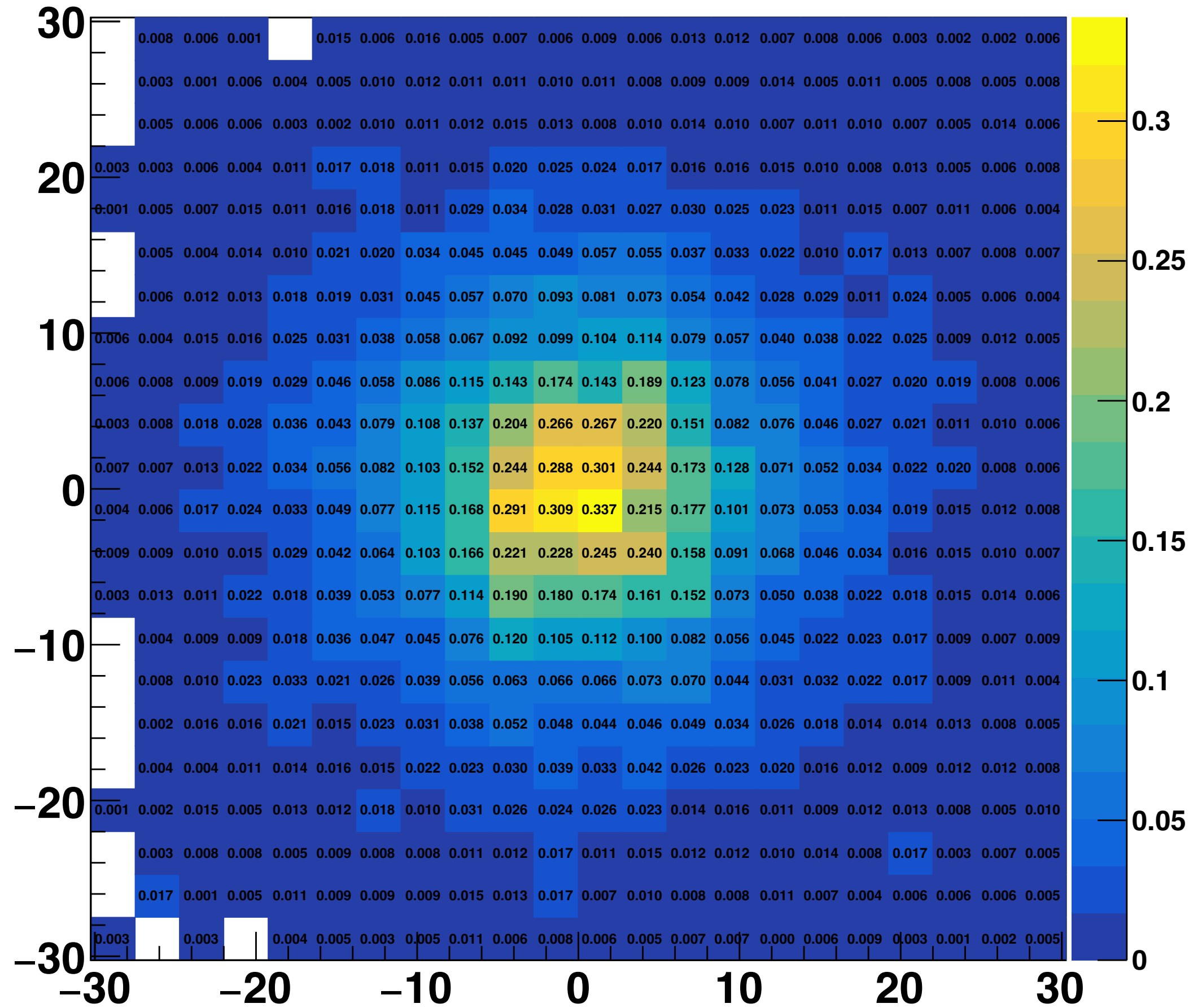

Factor non-uniformity - LG - PMMA - 2cm - 22x22 - 18. mm

Standard deviation: 0.164

Mean value: 0.110

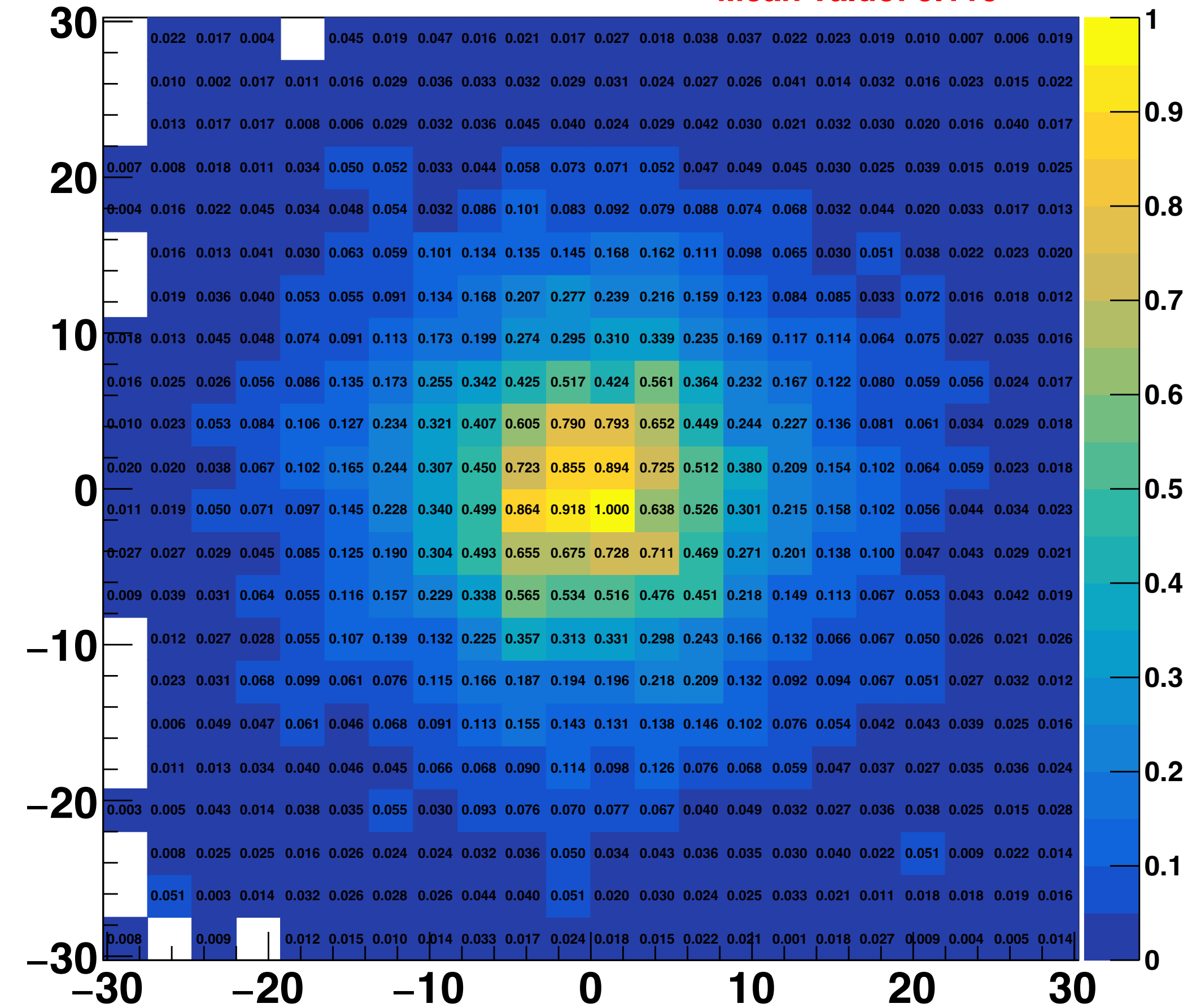

• Geometry 6

PMMA

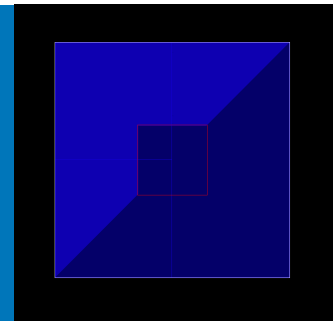

22x22 – Trap – 18 mm

Efficiency - LG - PMMA - 3cm - 22x22 - 18. mm

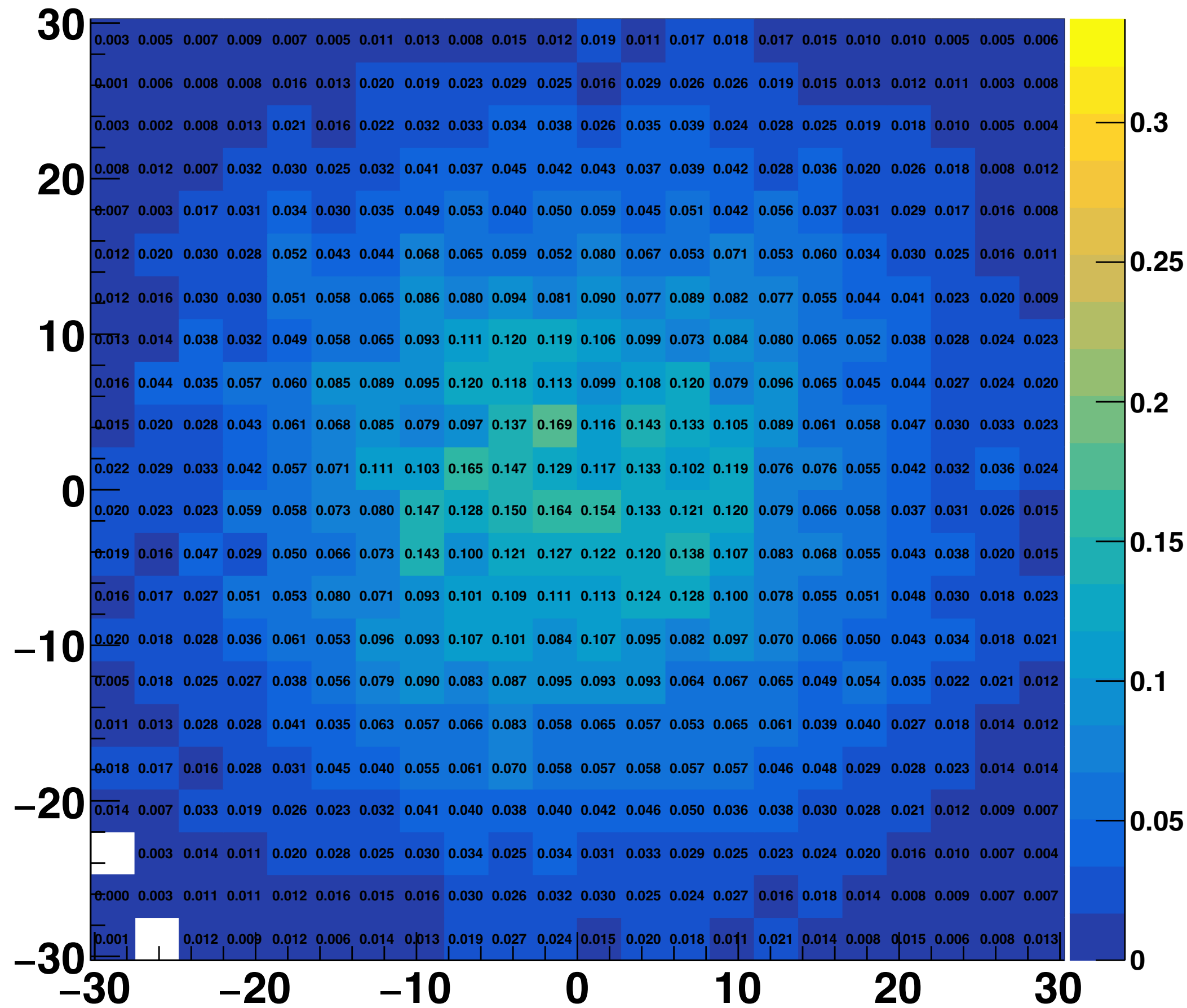

Factor non-uniformity - LG - PMMA - 3cm - 22x22 - 18. mm

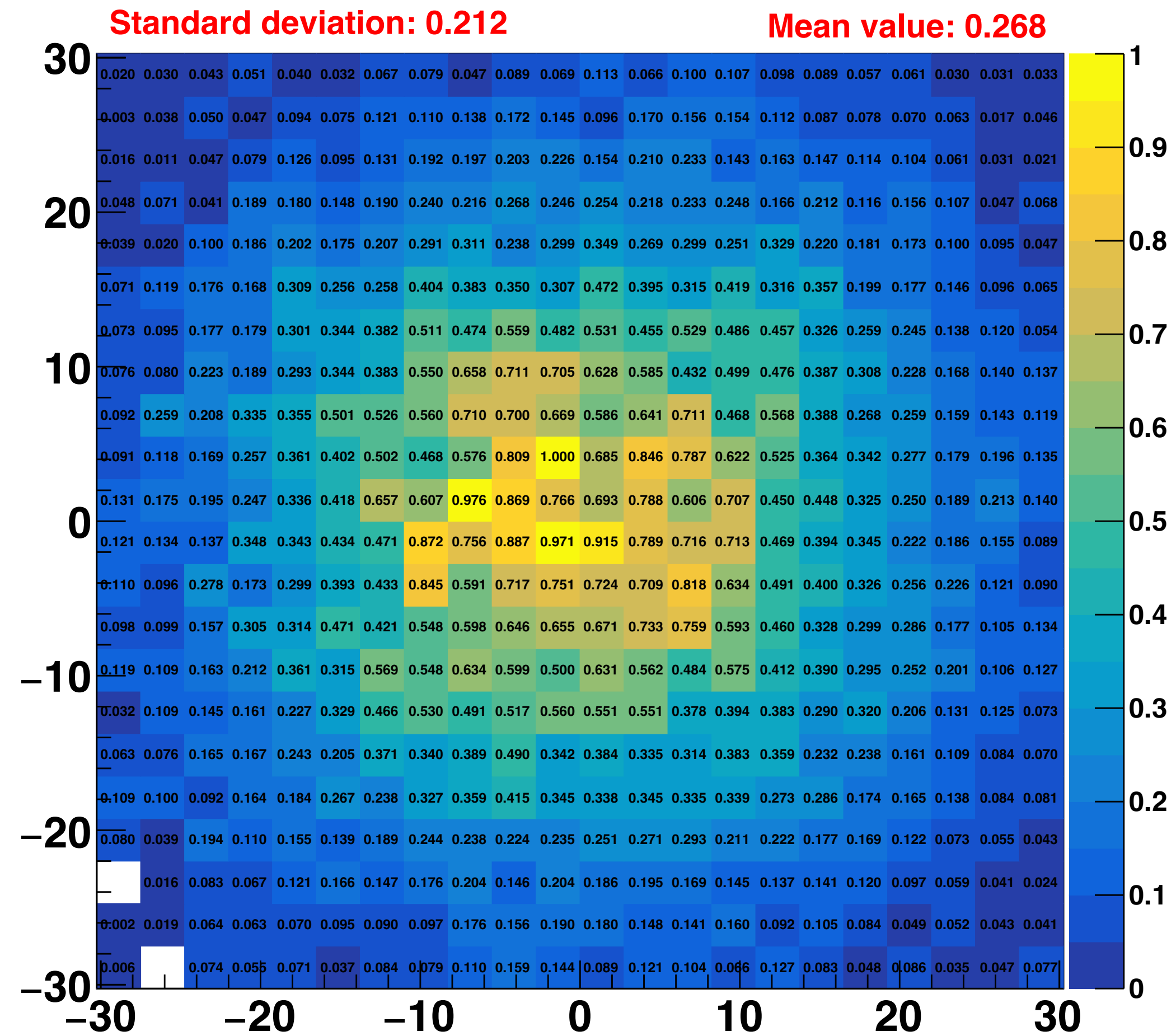

• Geometry 6

PMMA

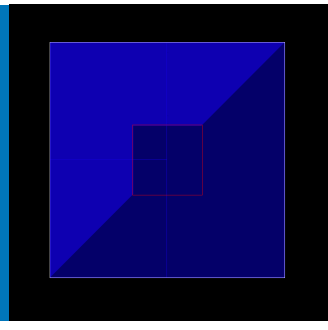

22x22 – Trap – 18 mm

Efficiency - LG - PMMA - 4cm - 22x22 - 18. mm

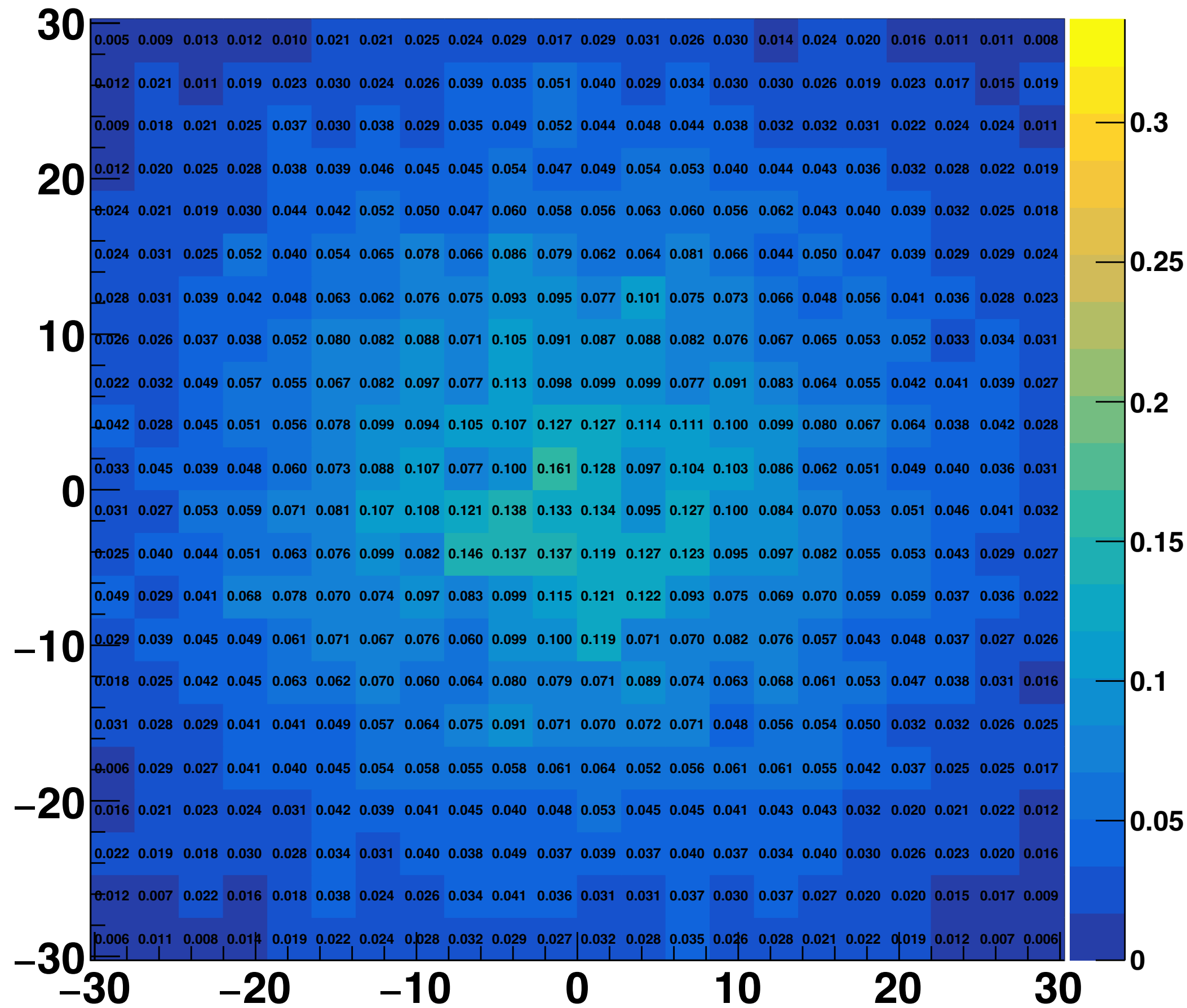

Factor non-uniformity - LG - PMMA - 4cm - 22x22 - 18. mm

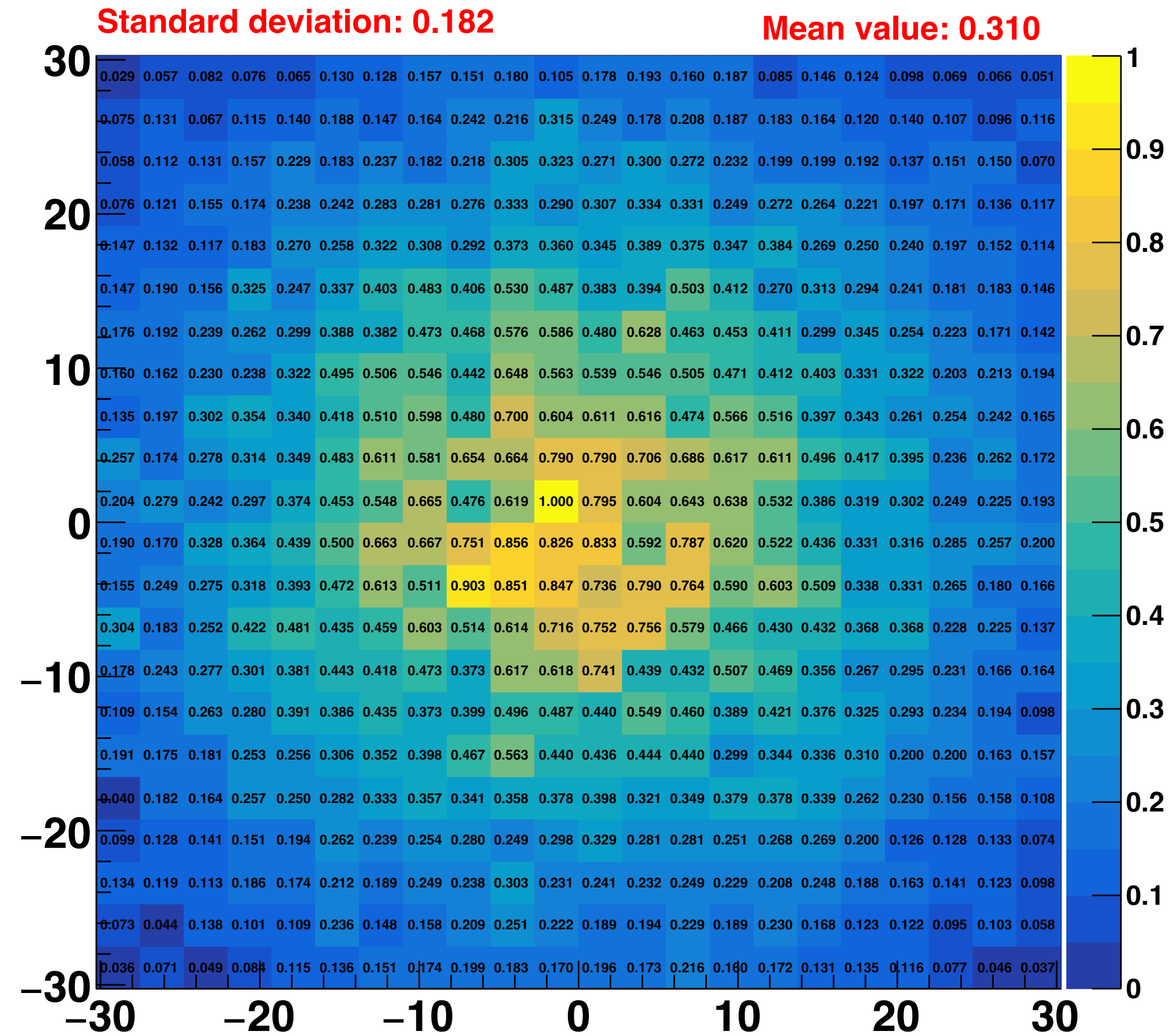

• Geometry 6

PMMA

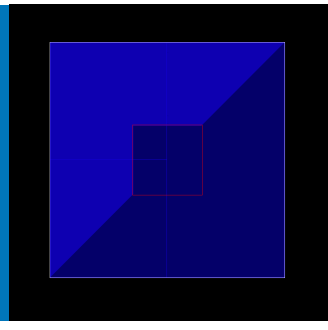

22x22 – Trap – 18 mm

Efficiency - LG - PMMA - 5cm - 22x22 - 18. mm

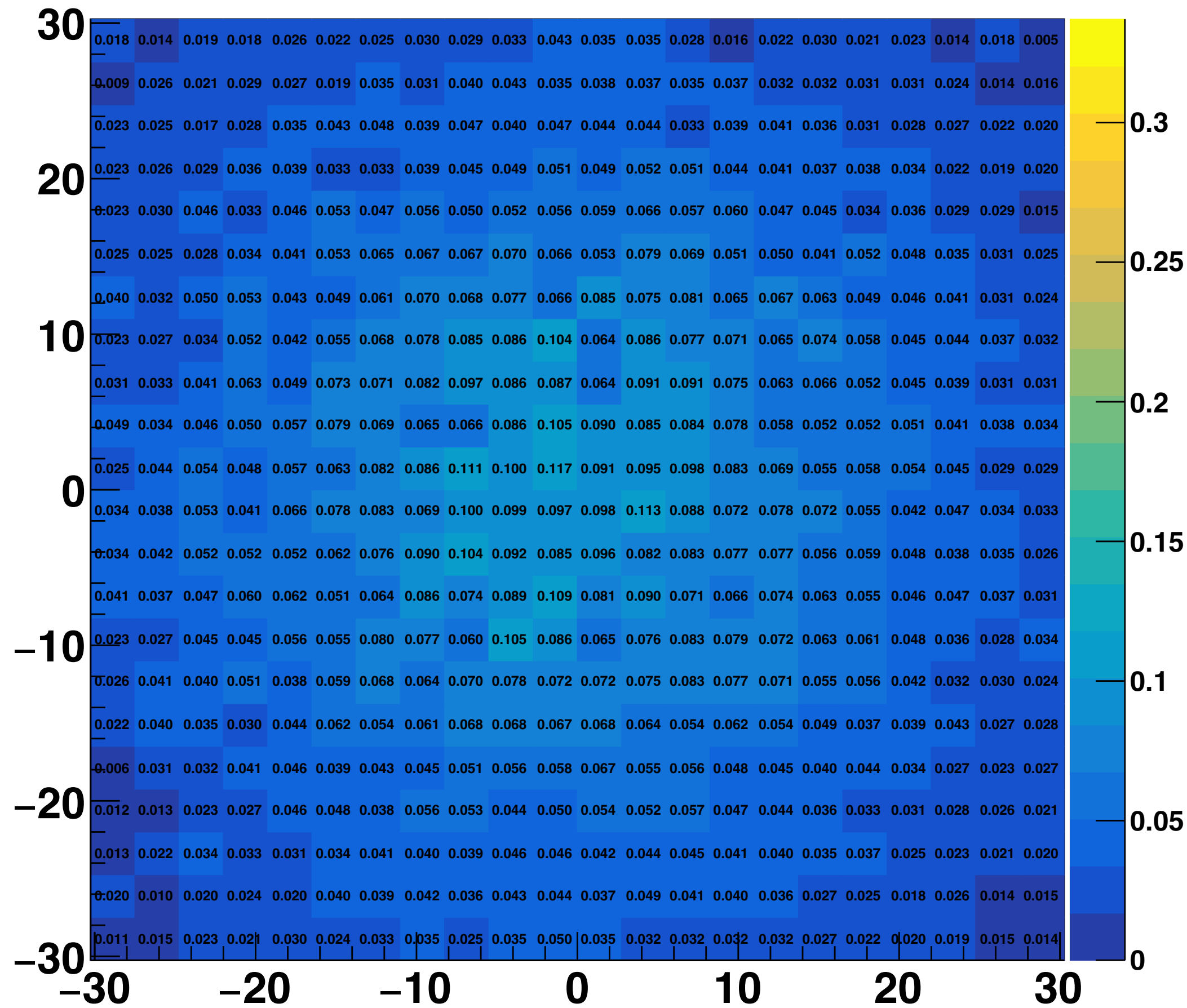

Factor non-uniformity - LG - PMMA - 5cm - 22x22 - 18. mm

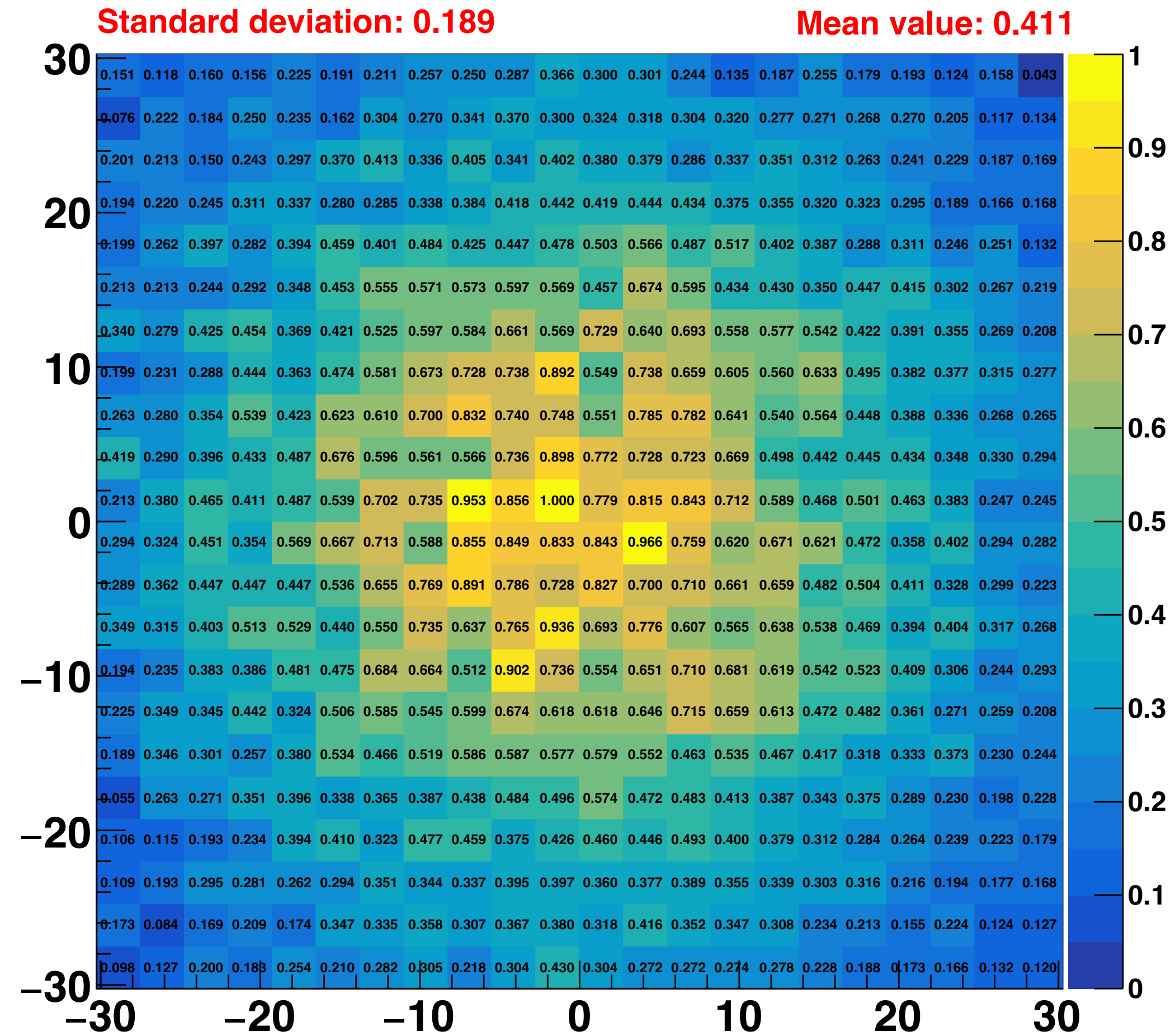

• Geometry 6

PMMA

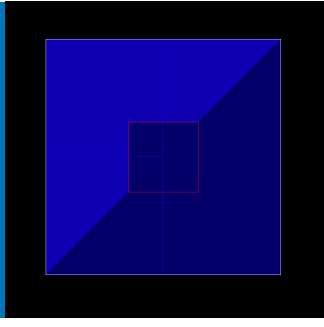

22x22 – Trap – 18 mm

Efficiency - LG - PMMA - 6cm - 22x22 - 18. mm

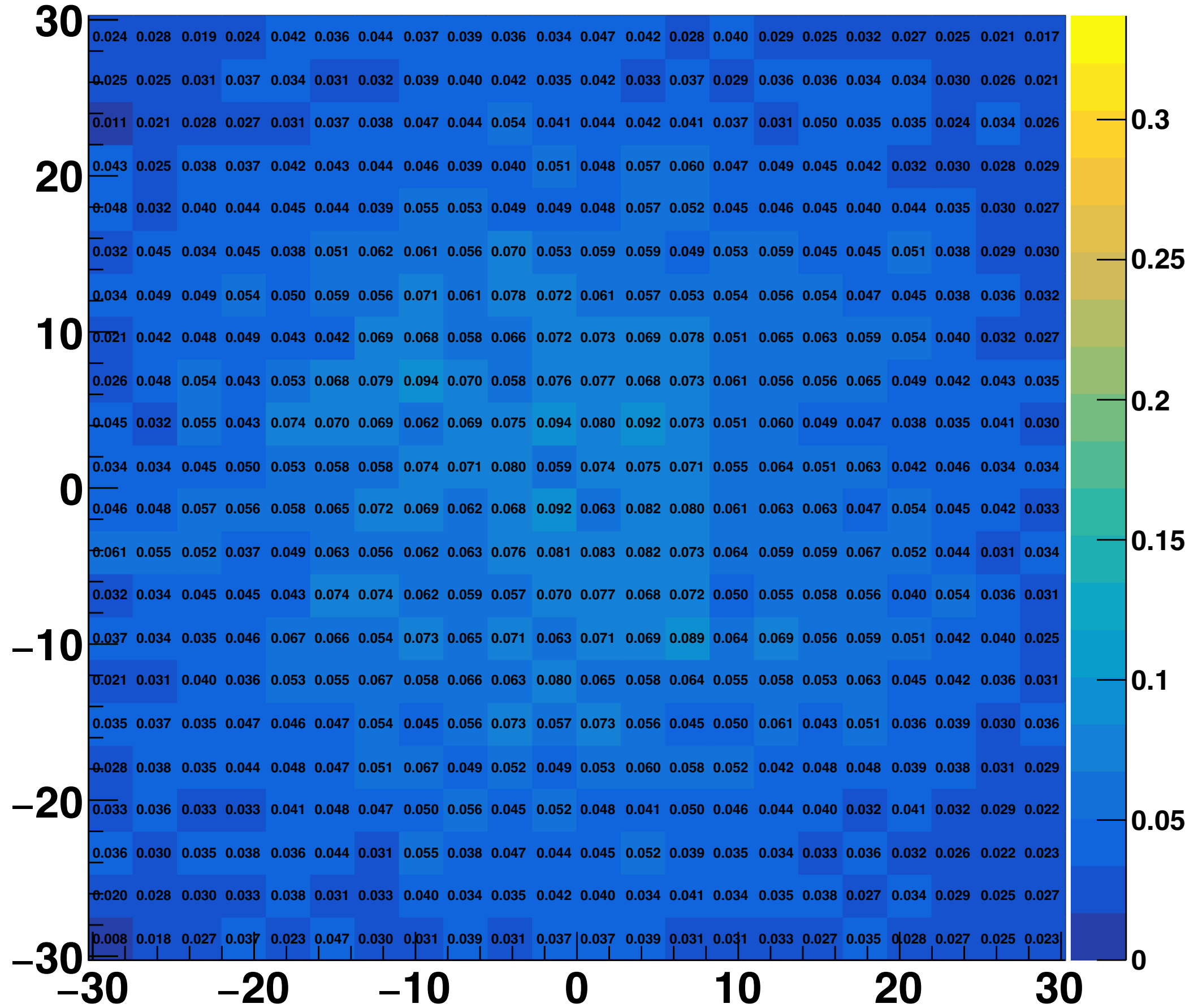

Factor non-uniformity - LG - PMMA - 6cm - 22x22 - 18. mm

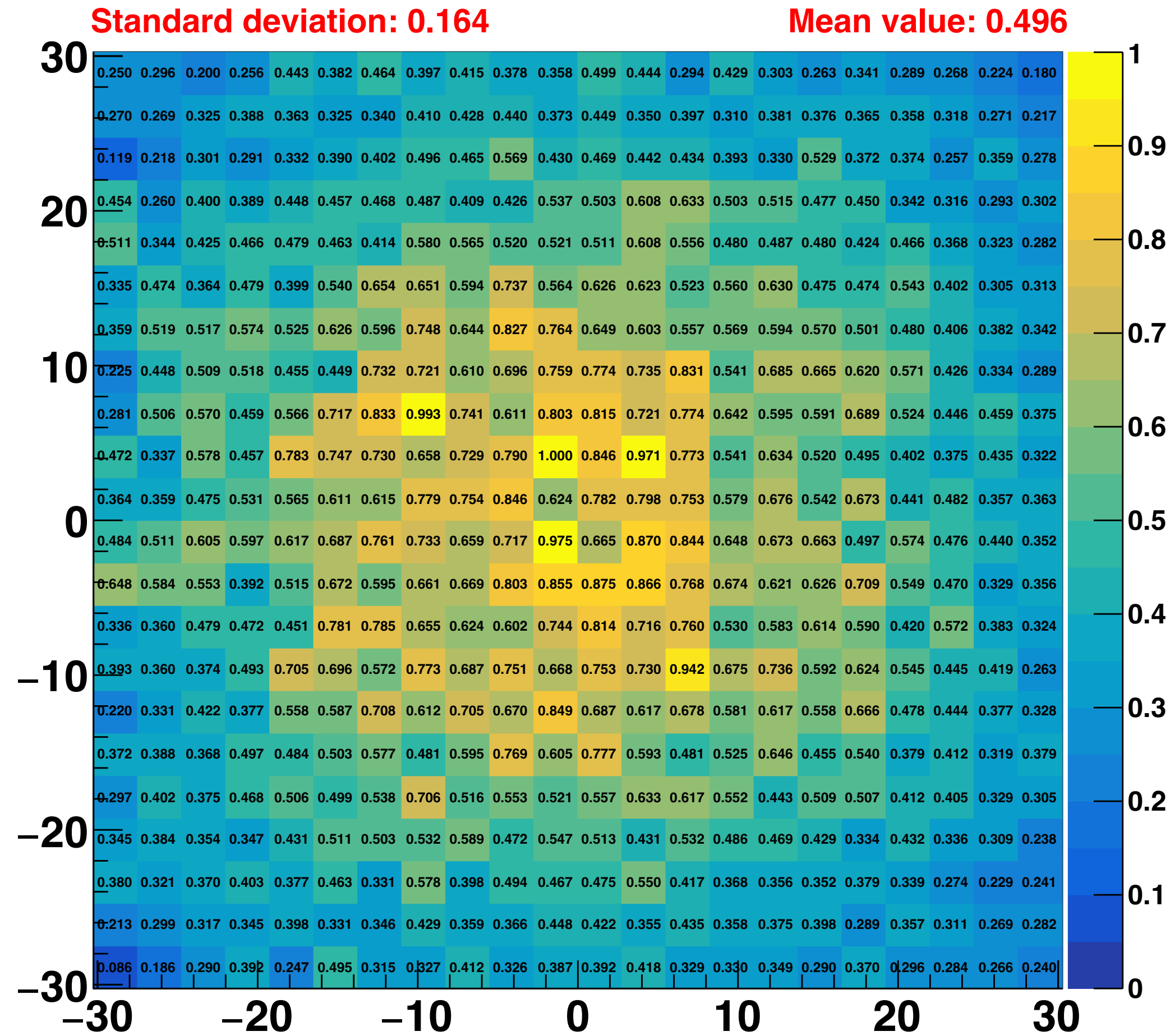

• Geometry 6

Air

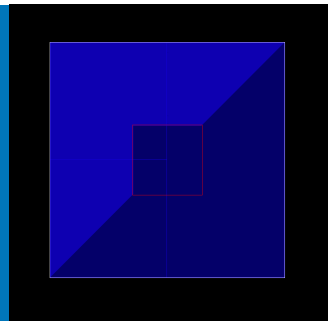

22x22 – Trap – 18 mm

Efficiency - LG - AIR - 2cm - 22x22 - 18. mm

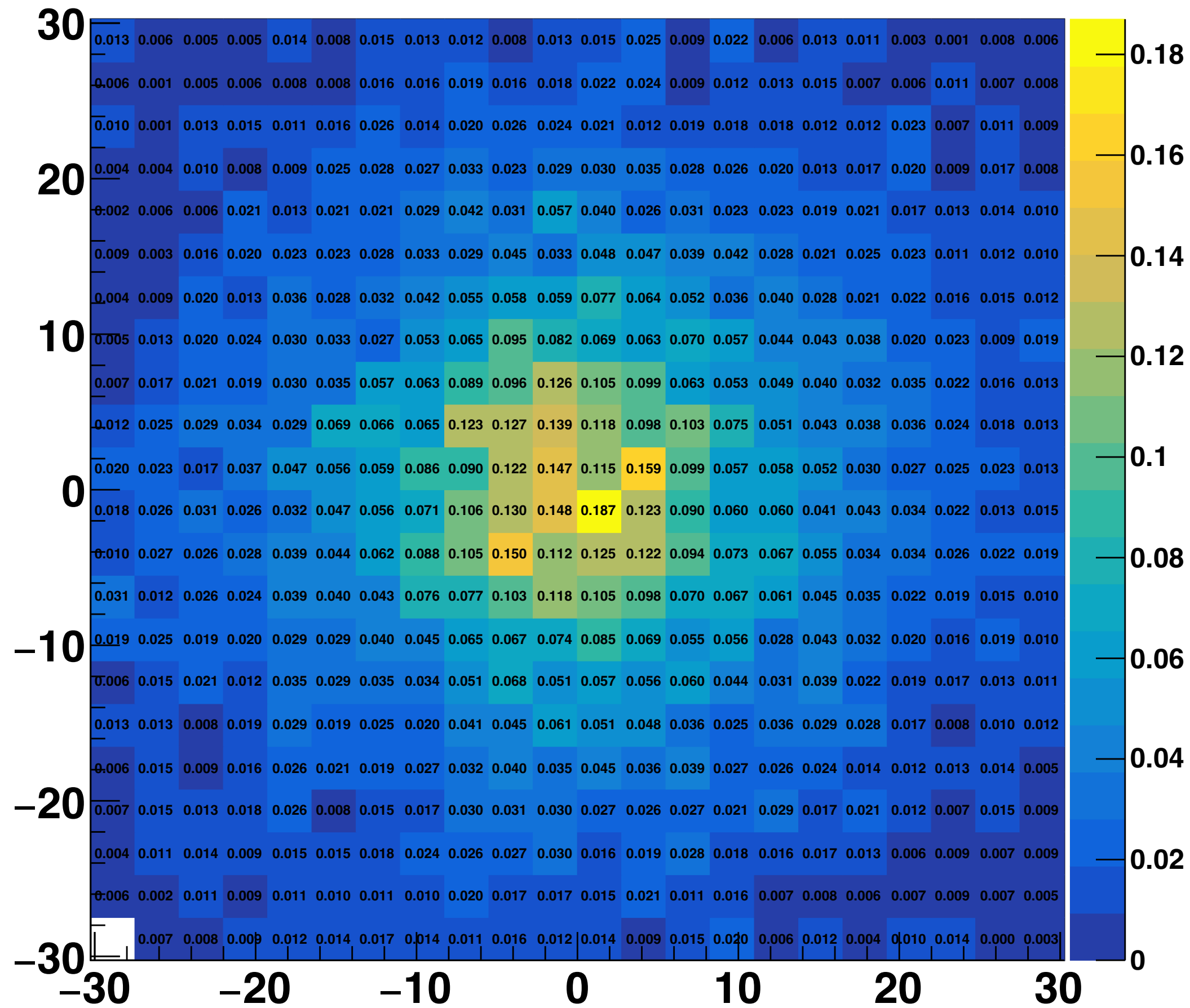

Factor non-uniformity - LG - Air - 2cm - 22x22 - 18. mm

Standard deviation: 0.159 **Mean value: 0.172**

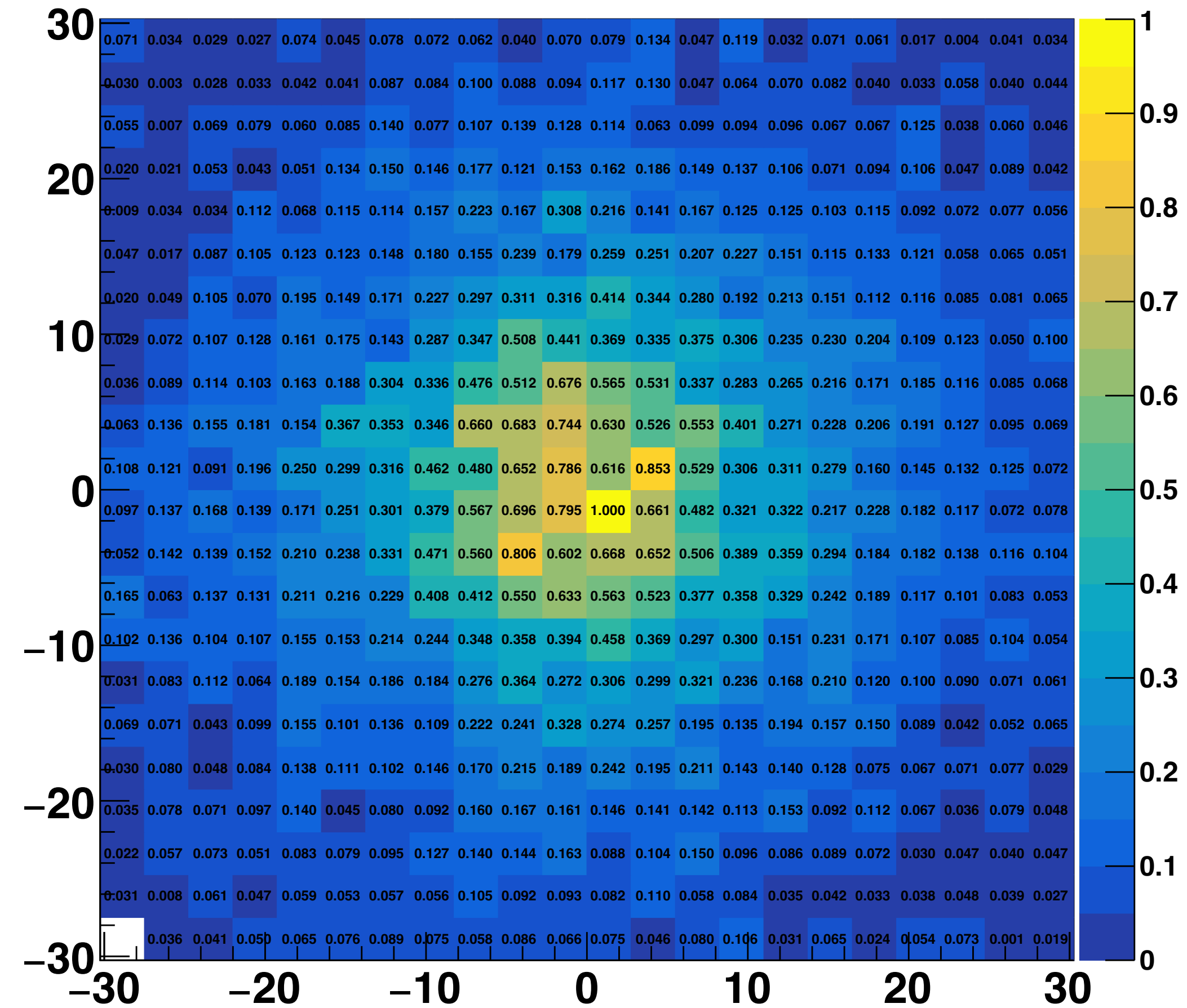

• Geometry 6

Air

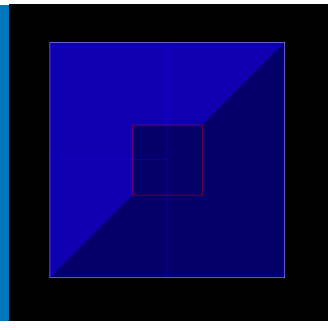

22x22 – Trap – 18 mm

Efficiency - LG - AIR - 3cm - 22x22 - 18. mm

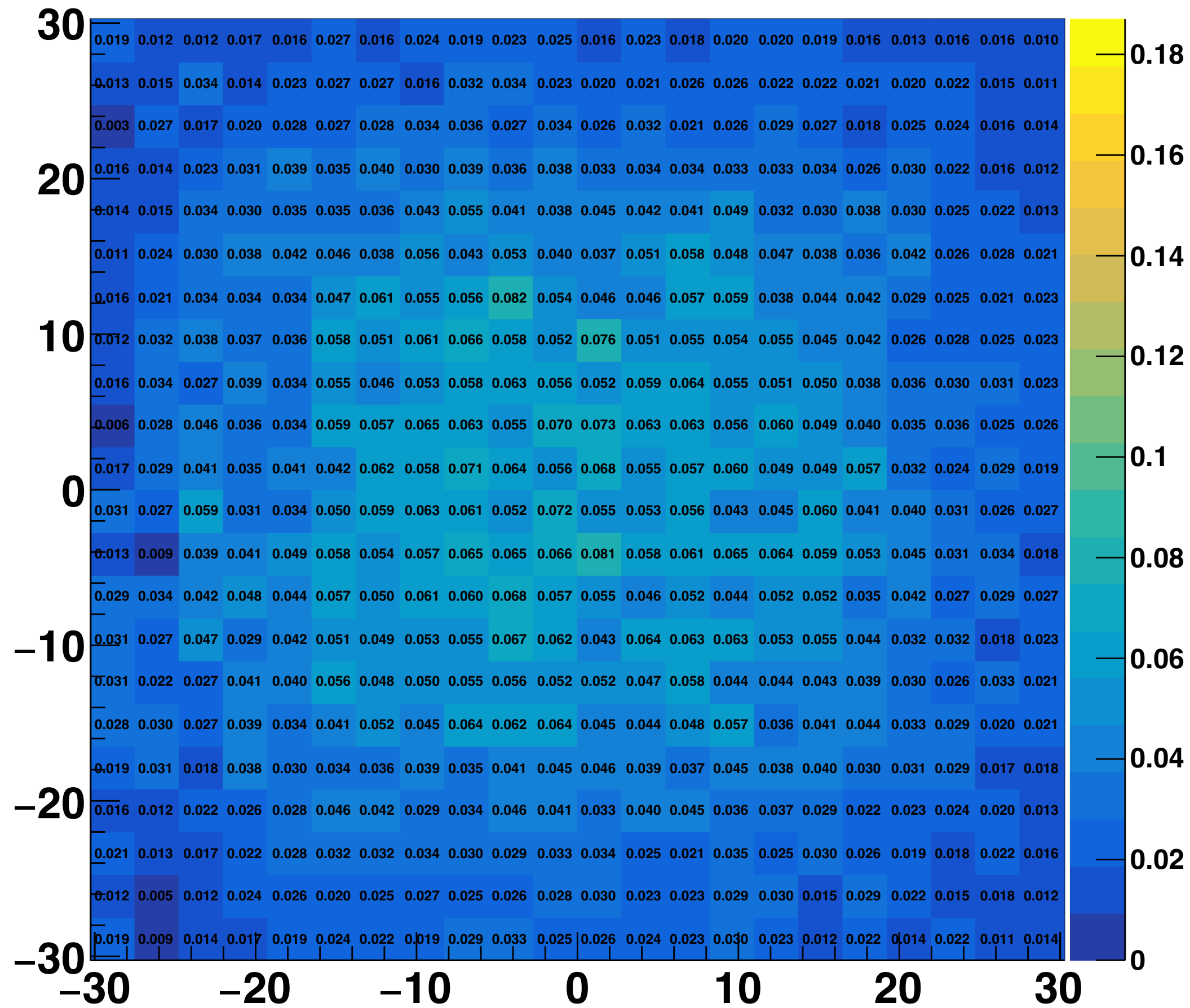

Factor non-uniformity - LG - Air - 3cm - 22x22 - 18. mm

Standard deviation: 0.191

Mean value: 0.441

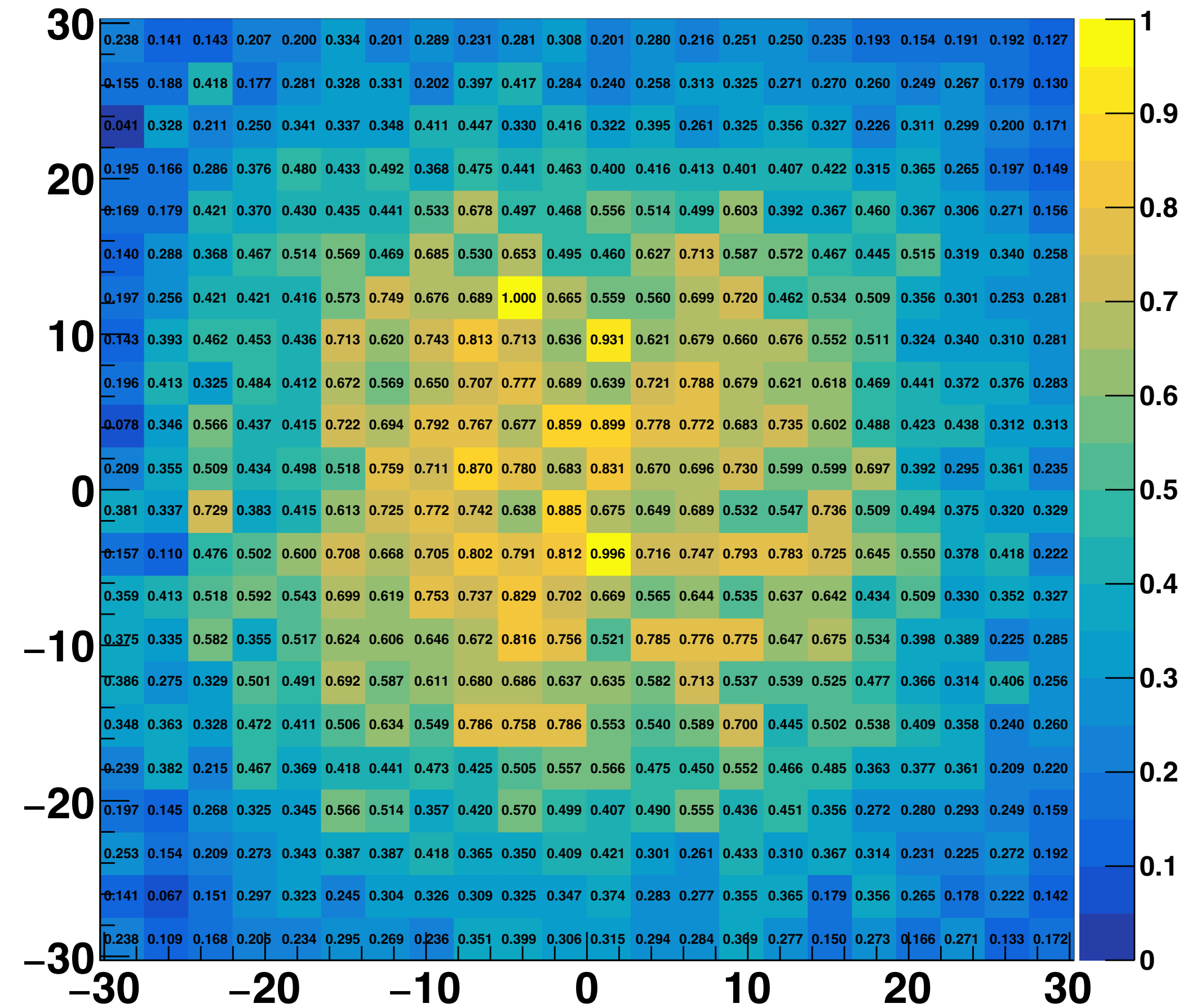

- Geometry 6

Air

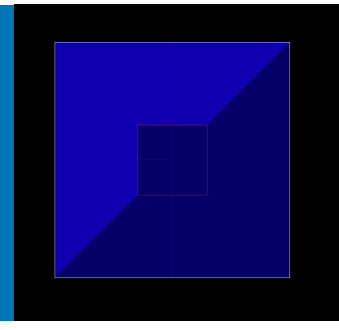

22x22 – Trap – 18 mm

Efficiency - LG - AIR - 4cm - 22x22 - 18. mm

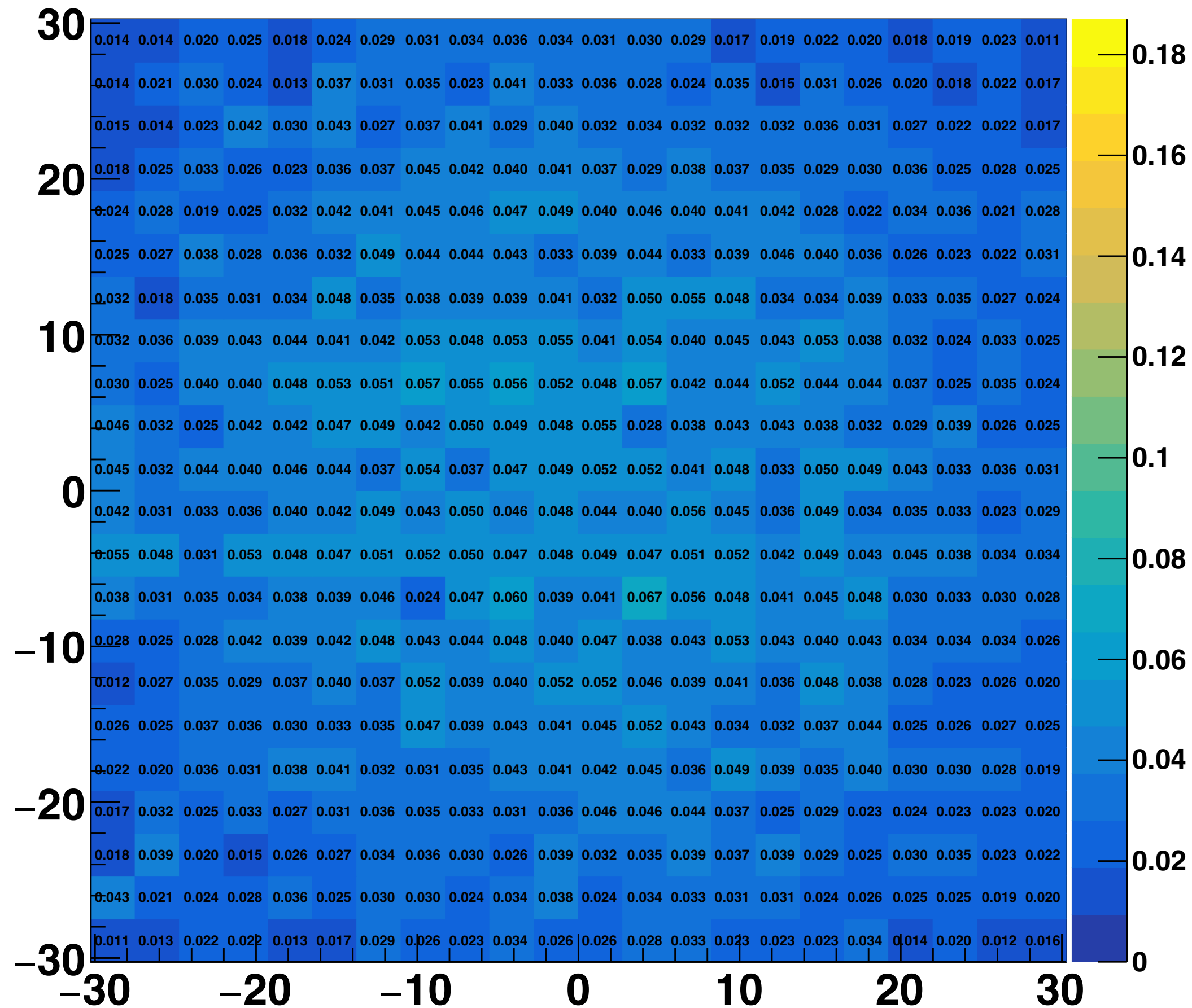

Factor non-uniformity - LG - Air - 4cm - 22x22 - 18. mm

Standard deviation: 0.154 **Mean value: 0.520**

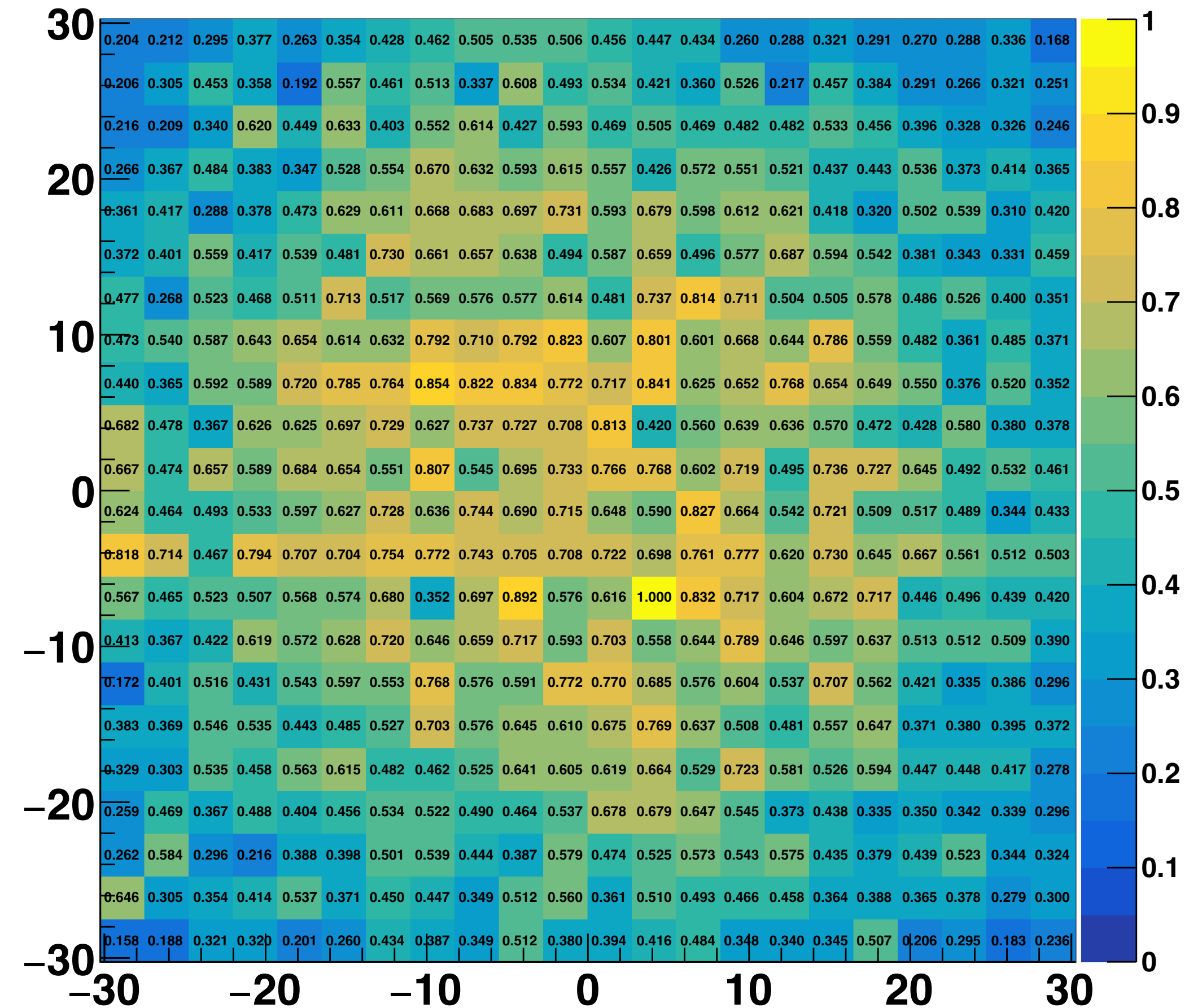

Geometry 6

Air

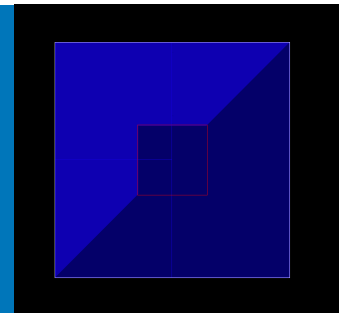

22x22 – Trap – 18 mm

Efficiency - LG - AIR - 5cm - 22x22 - 18. mm

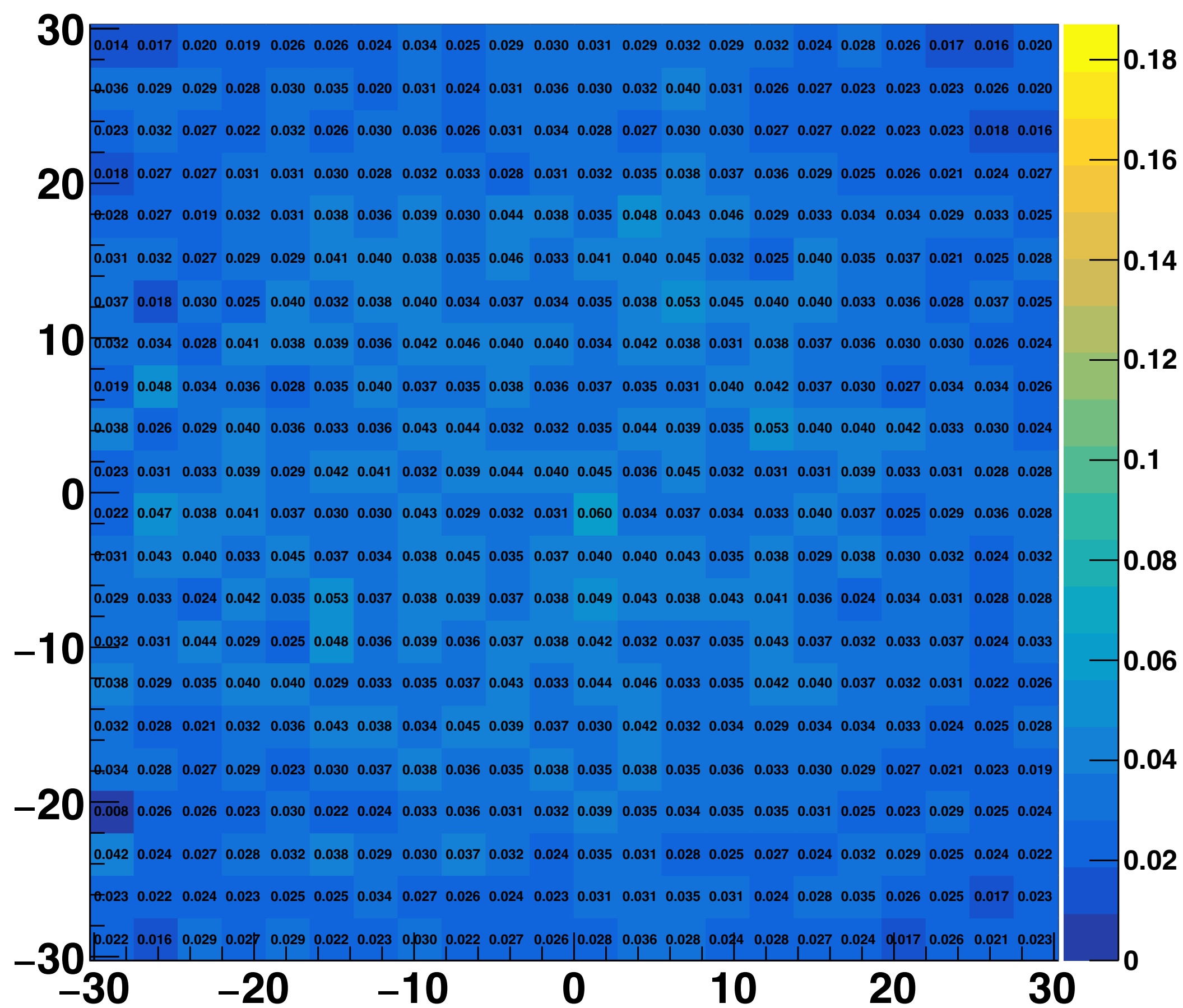

Factor non-uniformity - LG - Air - 5cm - 22x22 - 18. mm
Standard deviation: 0.118
Mean value: 0.536

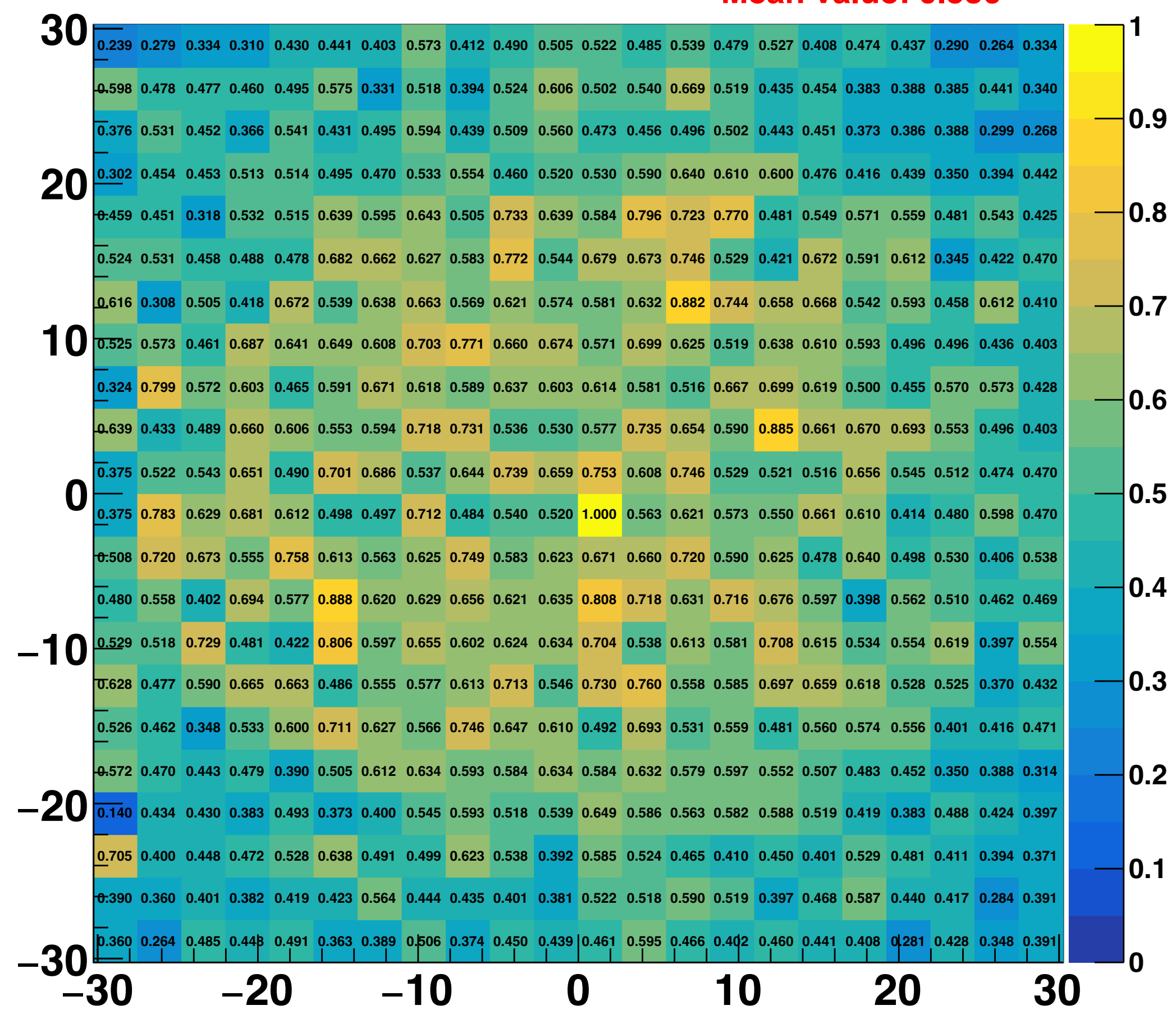

• Geometry 6

Air

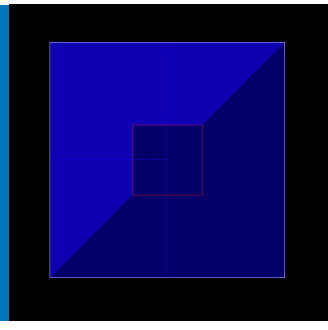

22x22 – Trap – 18 mm

Efficiency - LG - AIR - 6cm - 22x22 - 18. mm

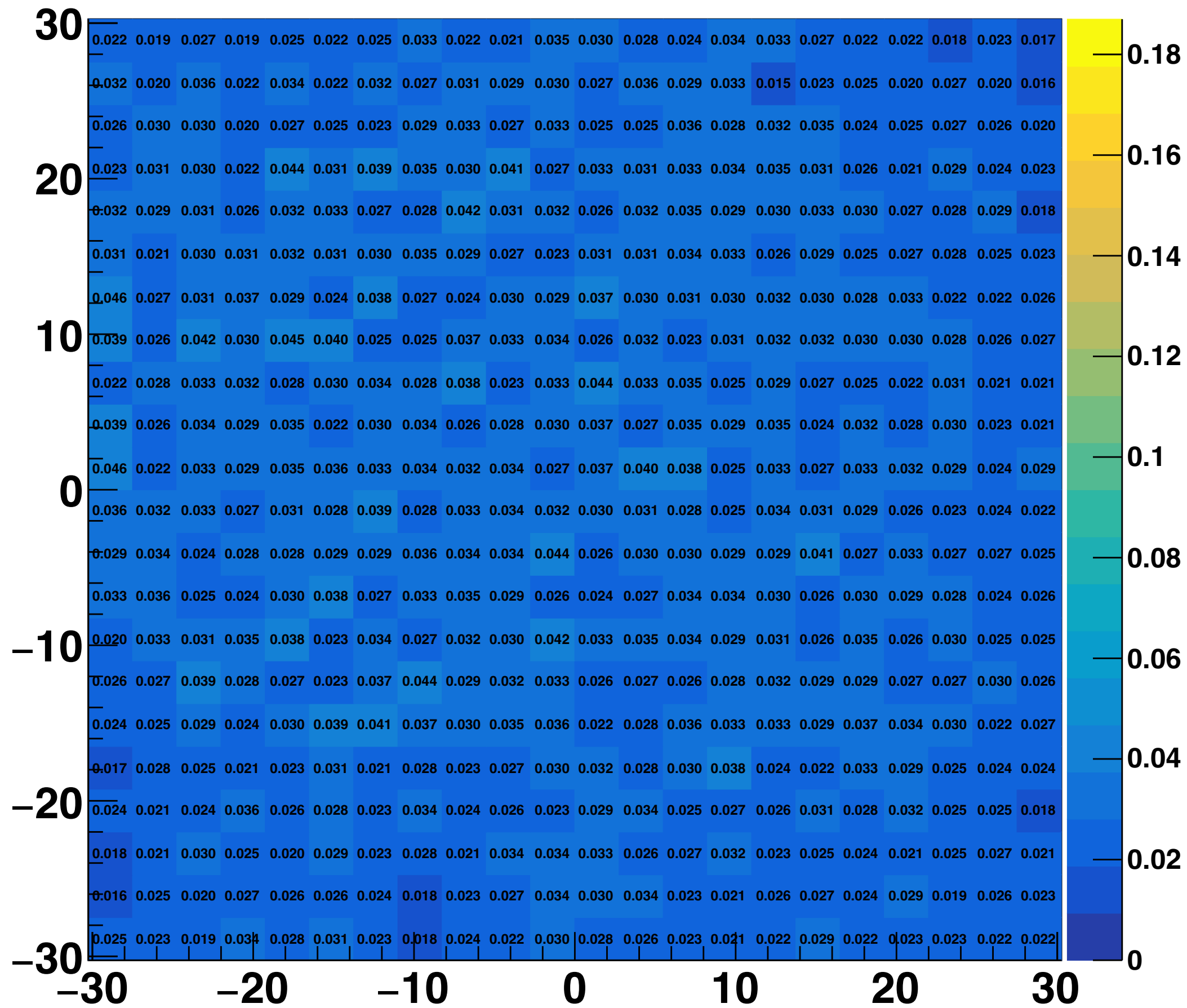

Factor non-uniformity - LG - Air - 6cm - 22x22 - 18. mm

Standard deviation: 0.118

Mean value: 0.624

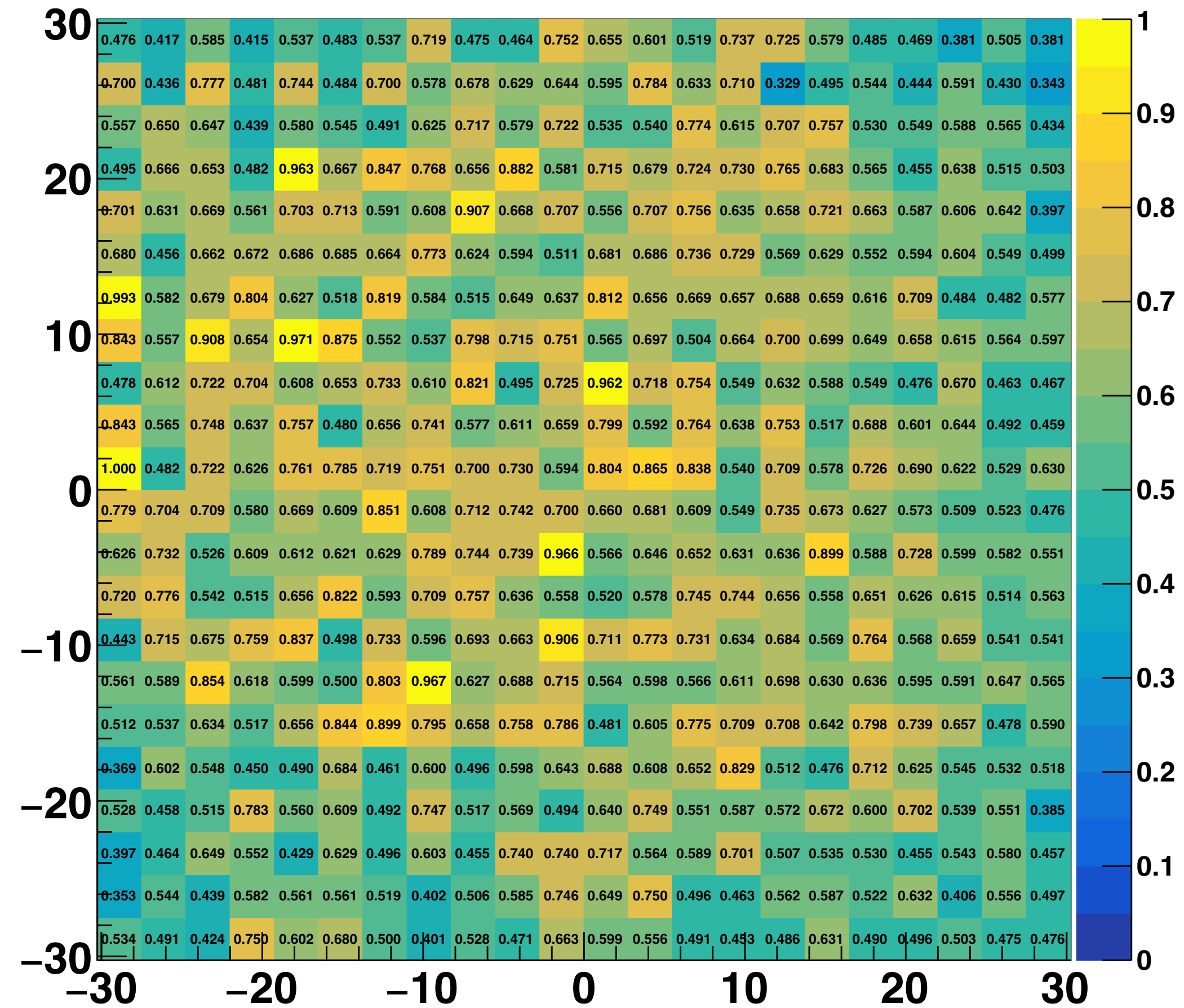

Geometry 6 -- PMMA - 22x22

Graph

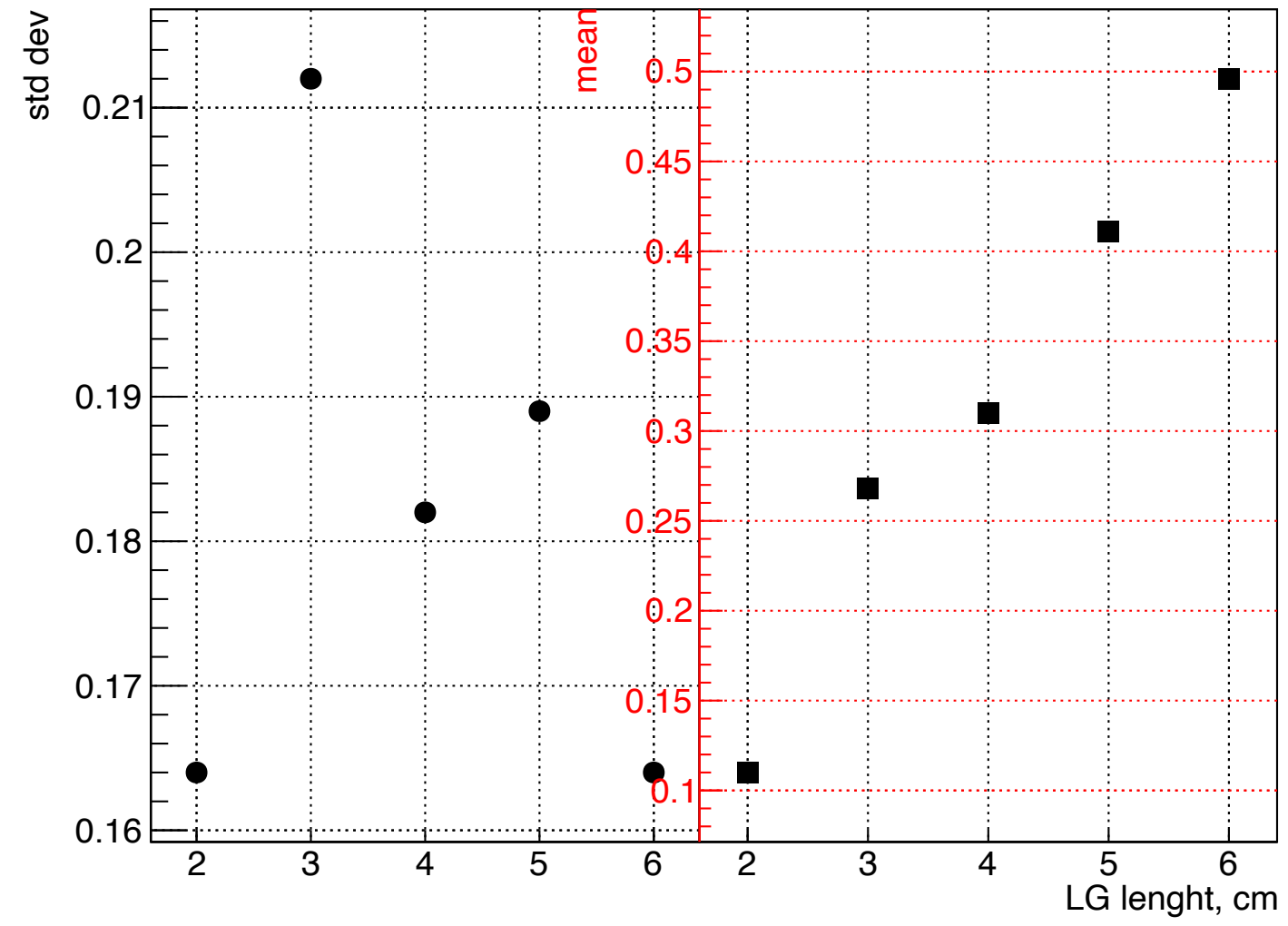

Geometry 1.1 -- PMMA - 18mm

Graph

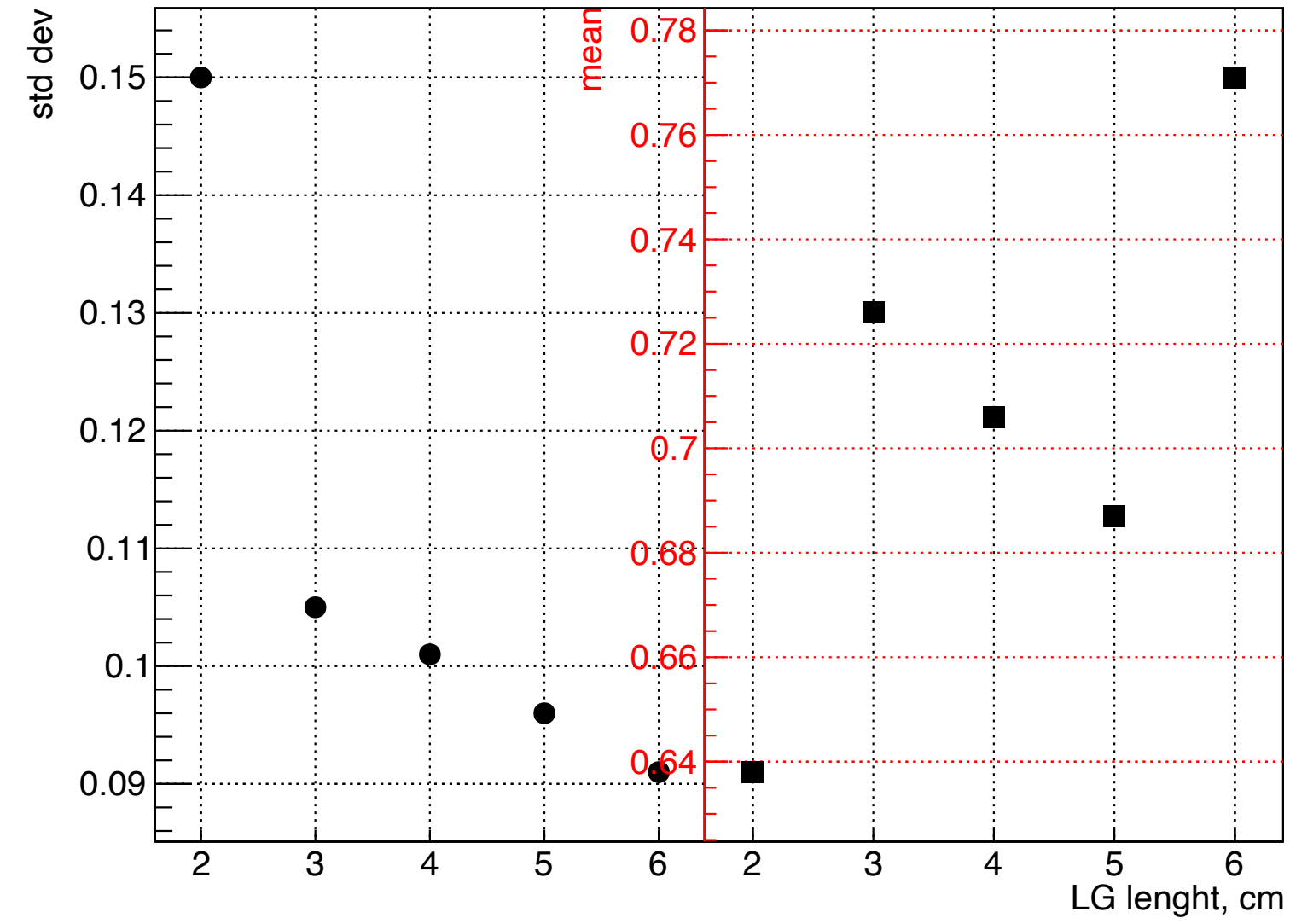

Geometry 4 -- PMMA - WC

Graph

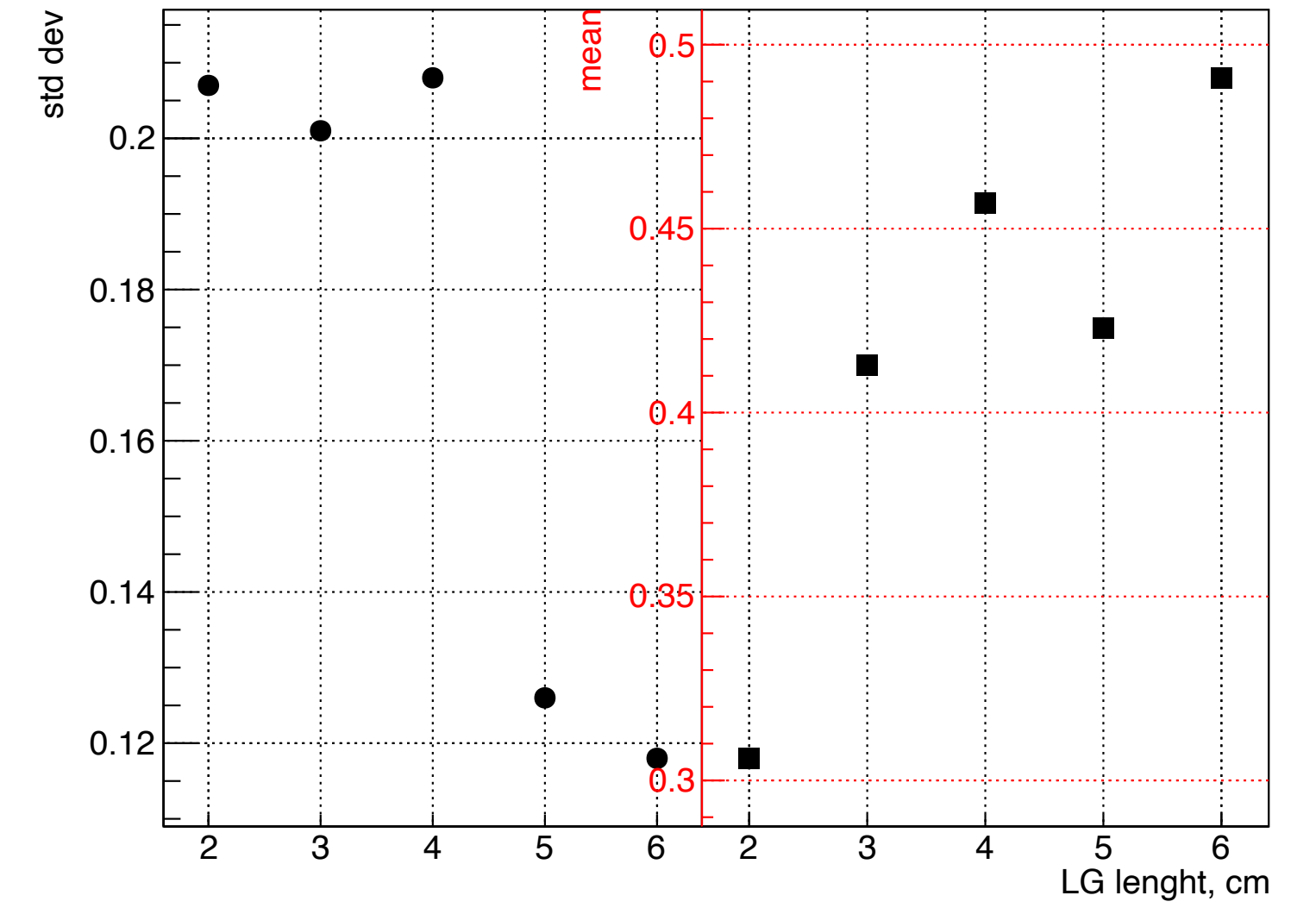

Geometry 6 -- AIR - 22x22

Graph

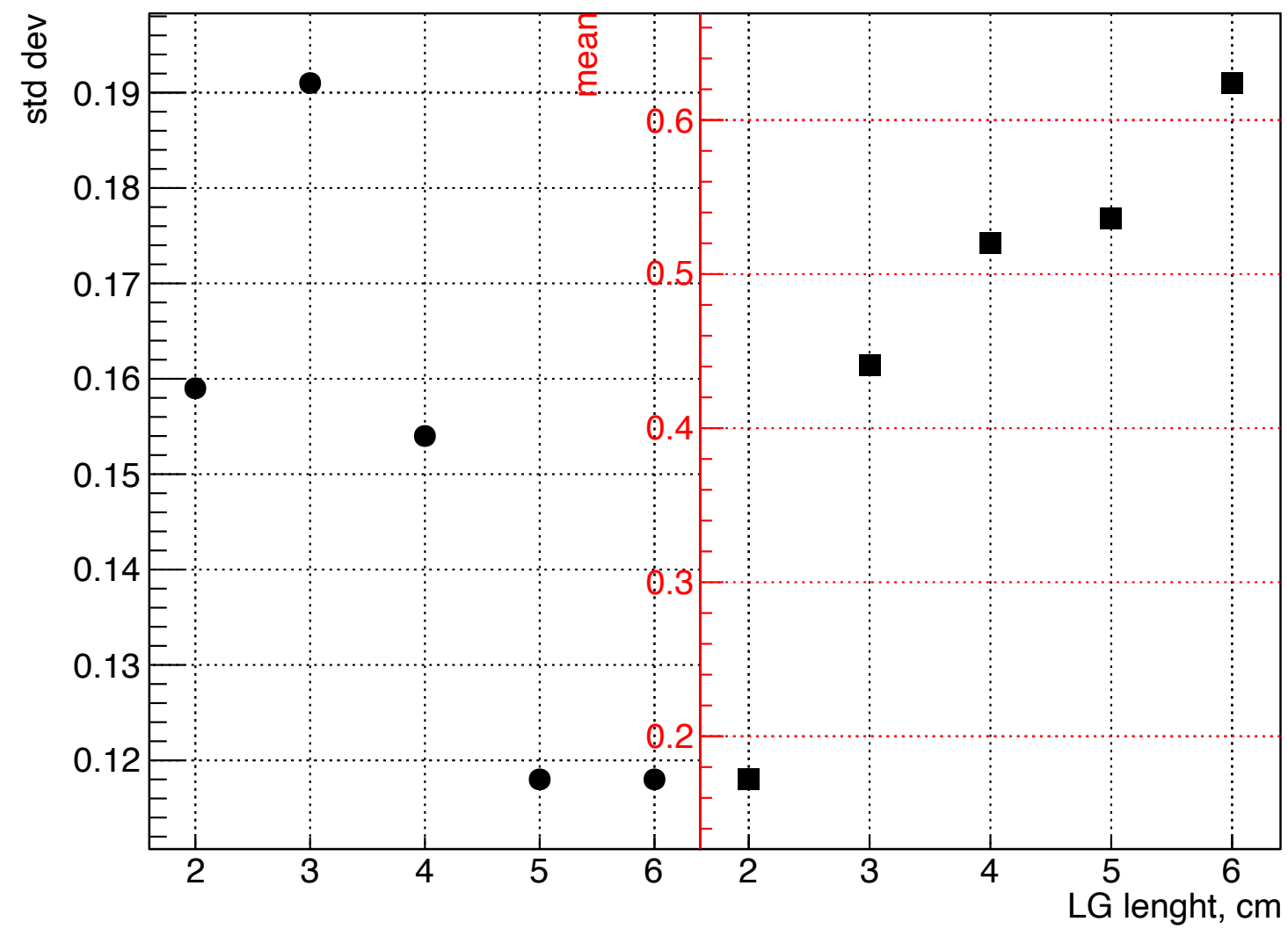

Geometry 1.1 -- AIR - 18mm

Graph

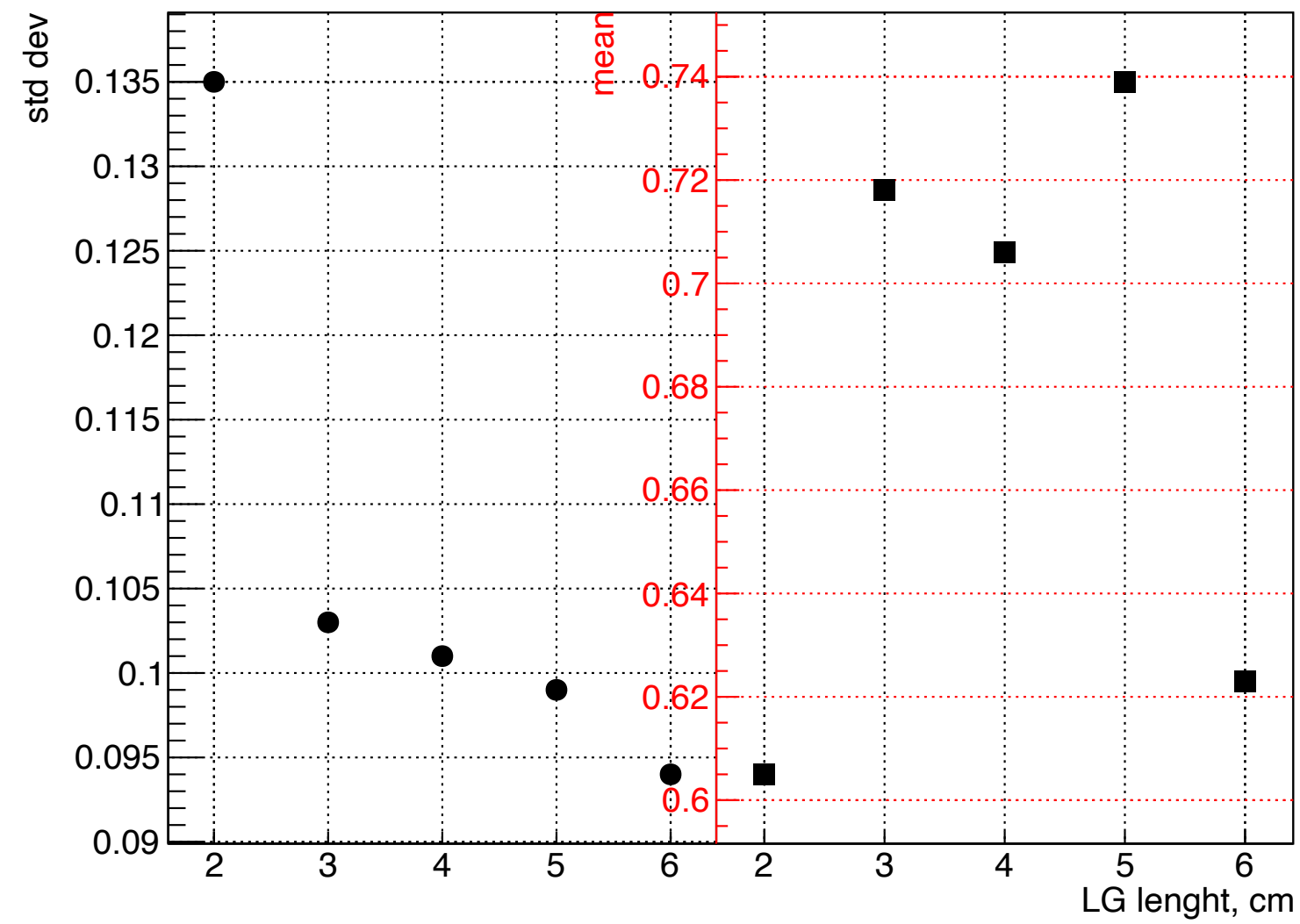

Geometry 4 -- AIR - WC

Graph

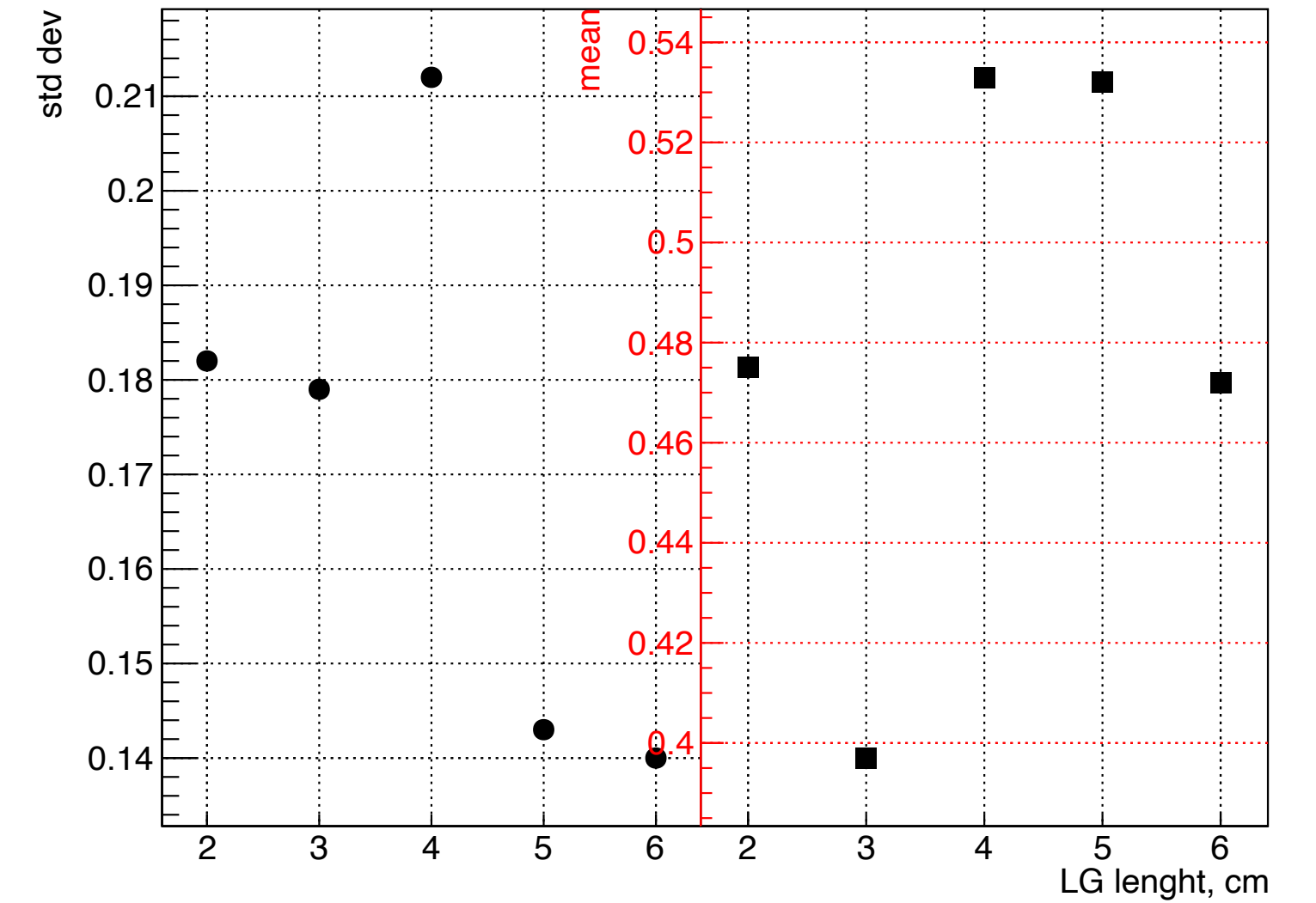

Geometry 1.1 -- PMMA - 18mm GI

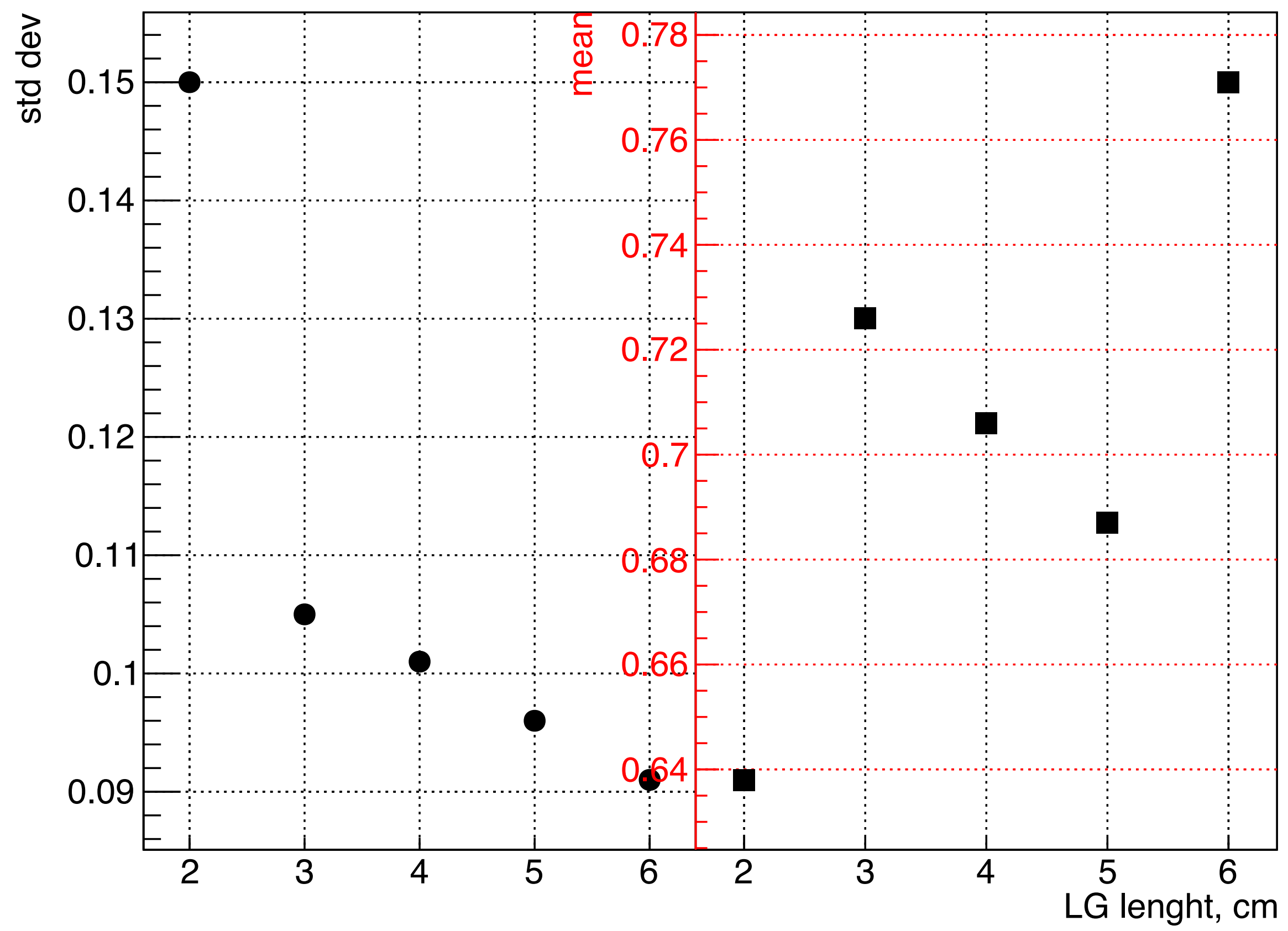

Geometry 1.1 -- AIR - 18mm Graph

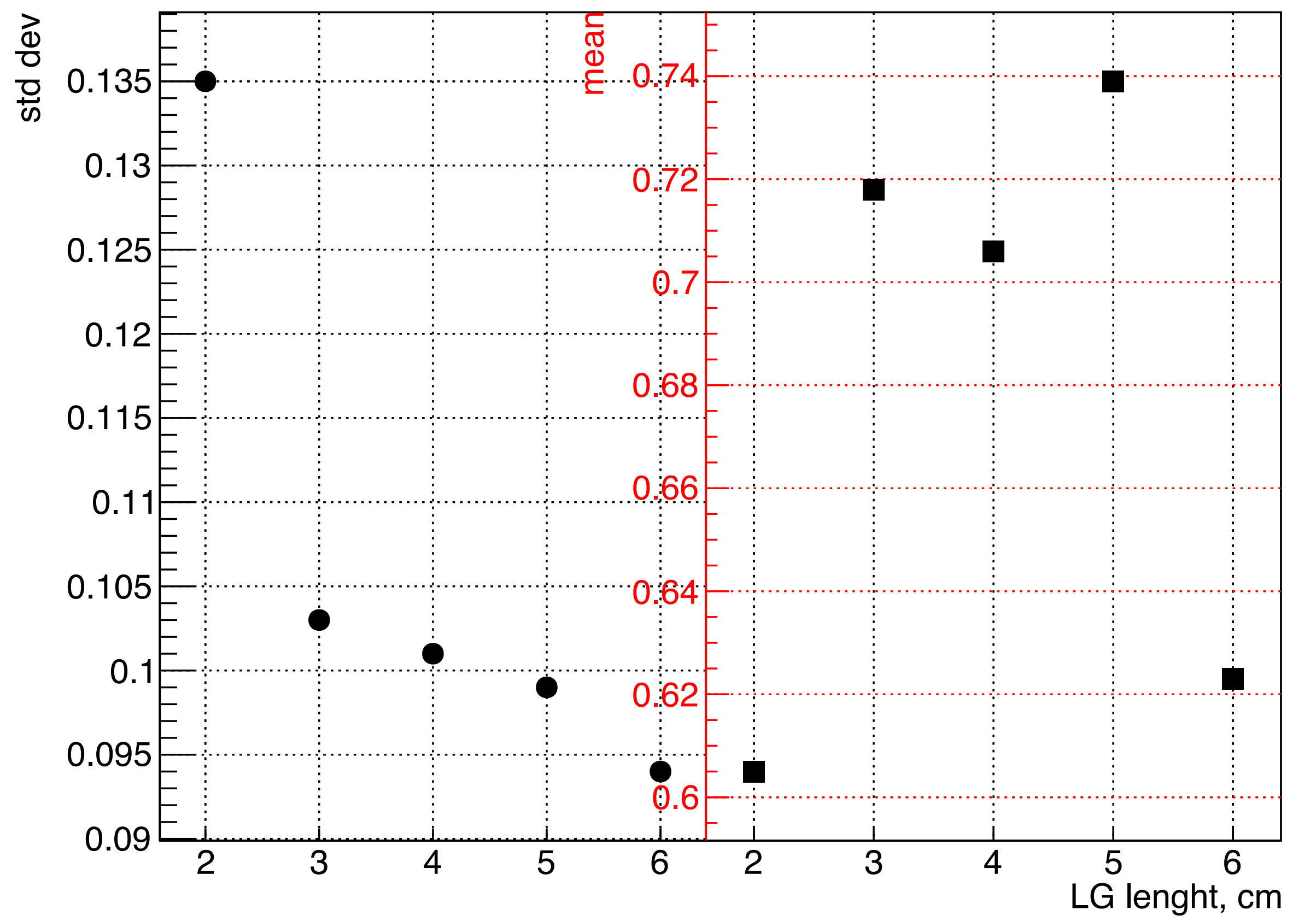

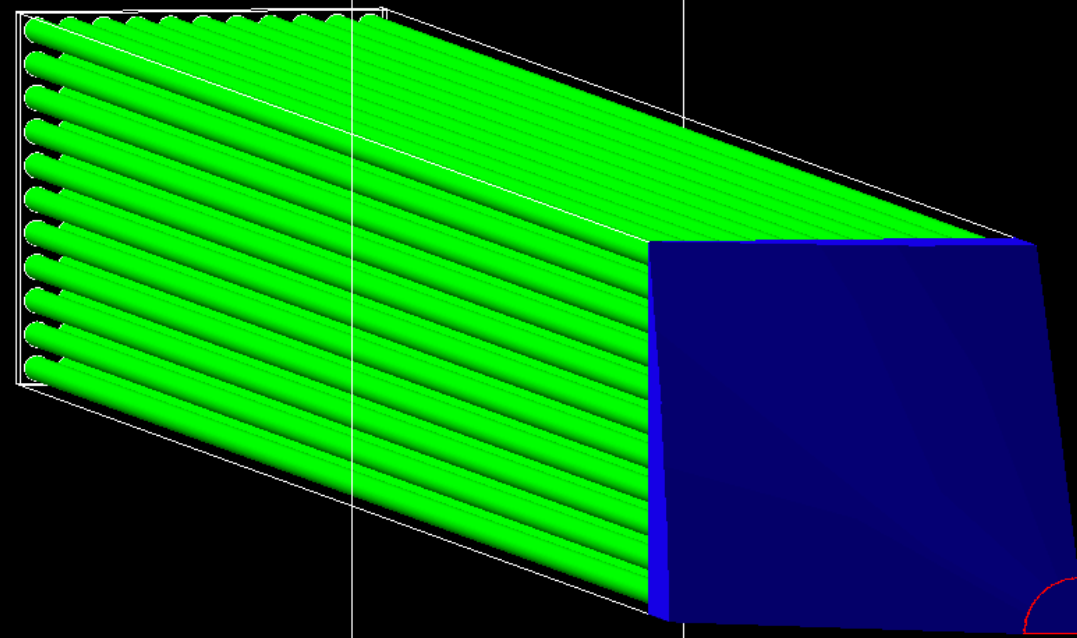

- **Geometry 7**

11x11 – FISH TAIL – 4.5 mm

PMTRad = 4.5 mm

Geometry7

PMMA

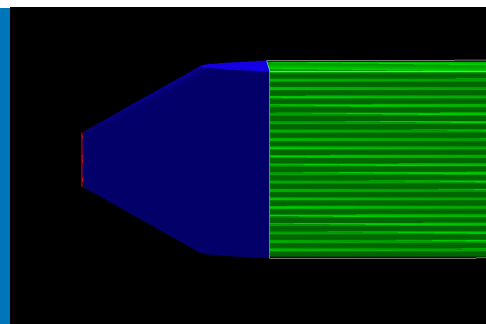

statistic 11.000 - muon 1 GeV

FISH TAIL
PMT 4.5

Efficiency - LG - PMMA - 2cm - base round - 4.5 mm

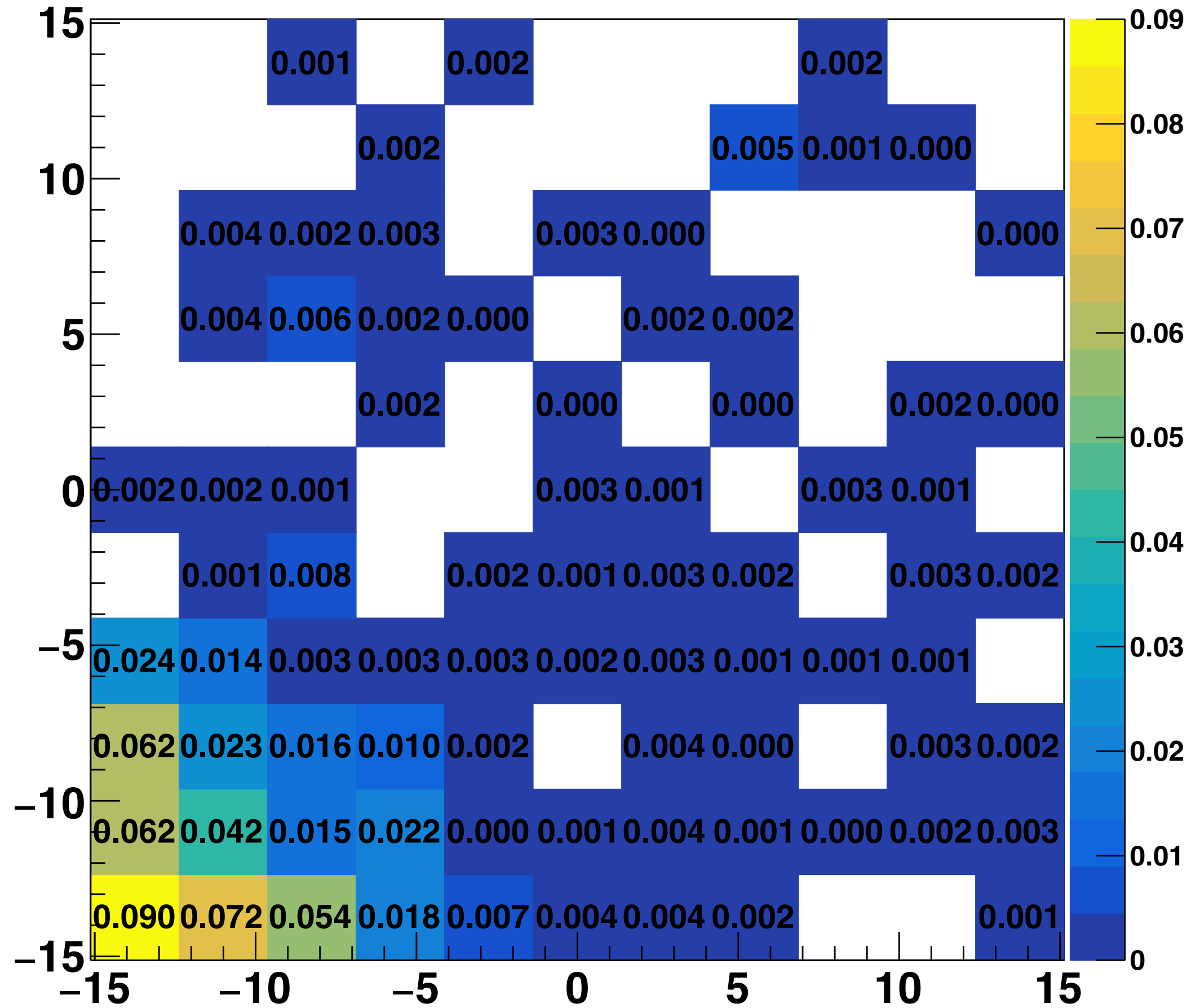

Factor non-uniformity - LG - PMMA - 2cm - base round - 4.5 mm

Standard deviation: 0.192

Mean value: 0.094

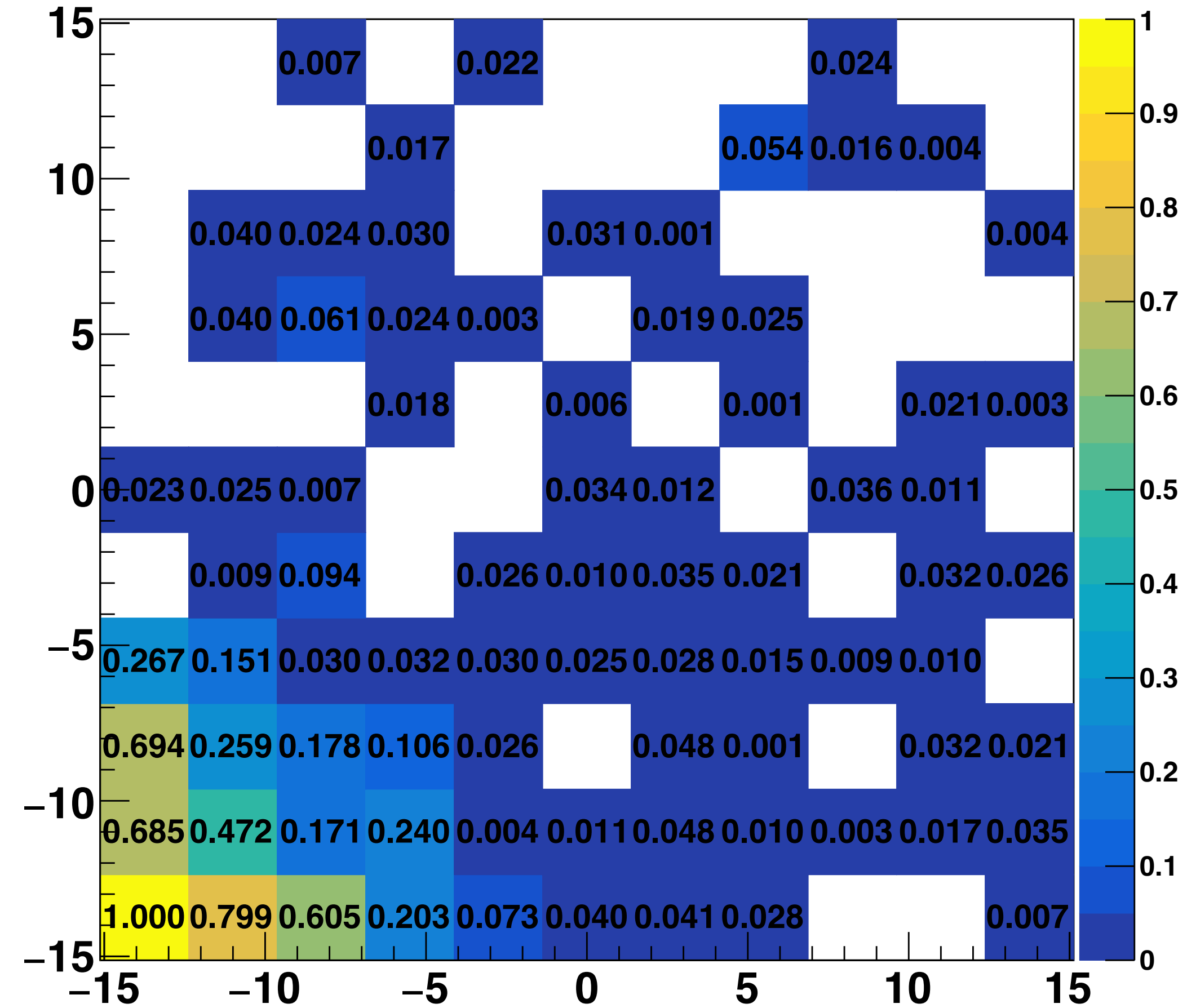

Geometry7

PMMA

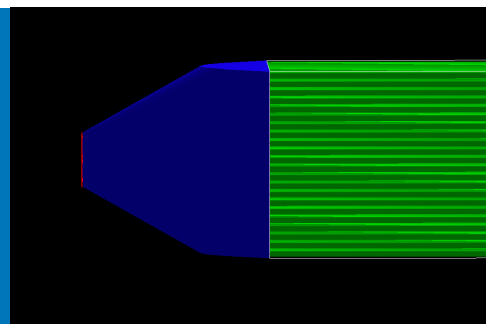

statistic 11.000 - muon 1 GeV

FISH TAIL
PMT 4.5

Efficiency - LG - PMMA - 3cm - base round - 4.5 mm

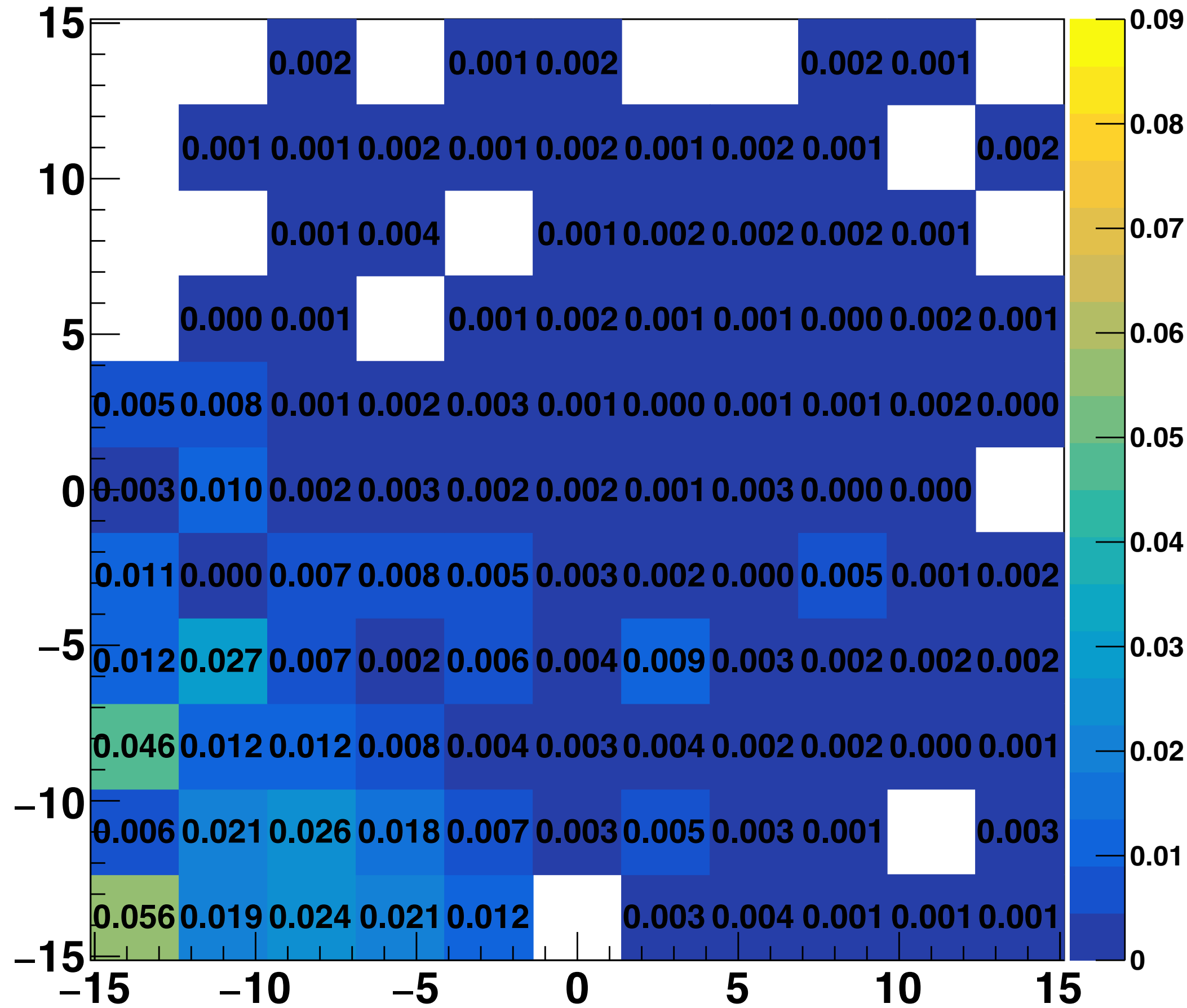

Factor non-uniformity - LG - PMMA - 3cm - base round - 4.5 mm

Standard deviation: 0.153

Mean value: 0.093

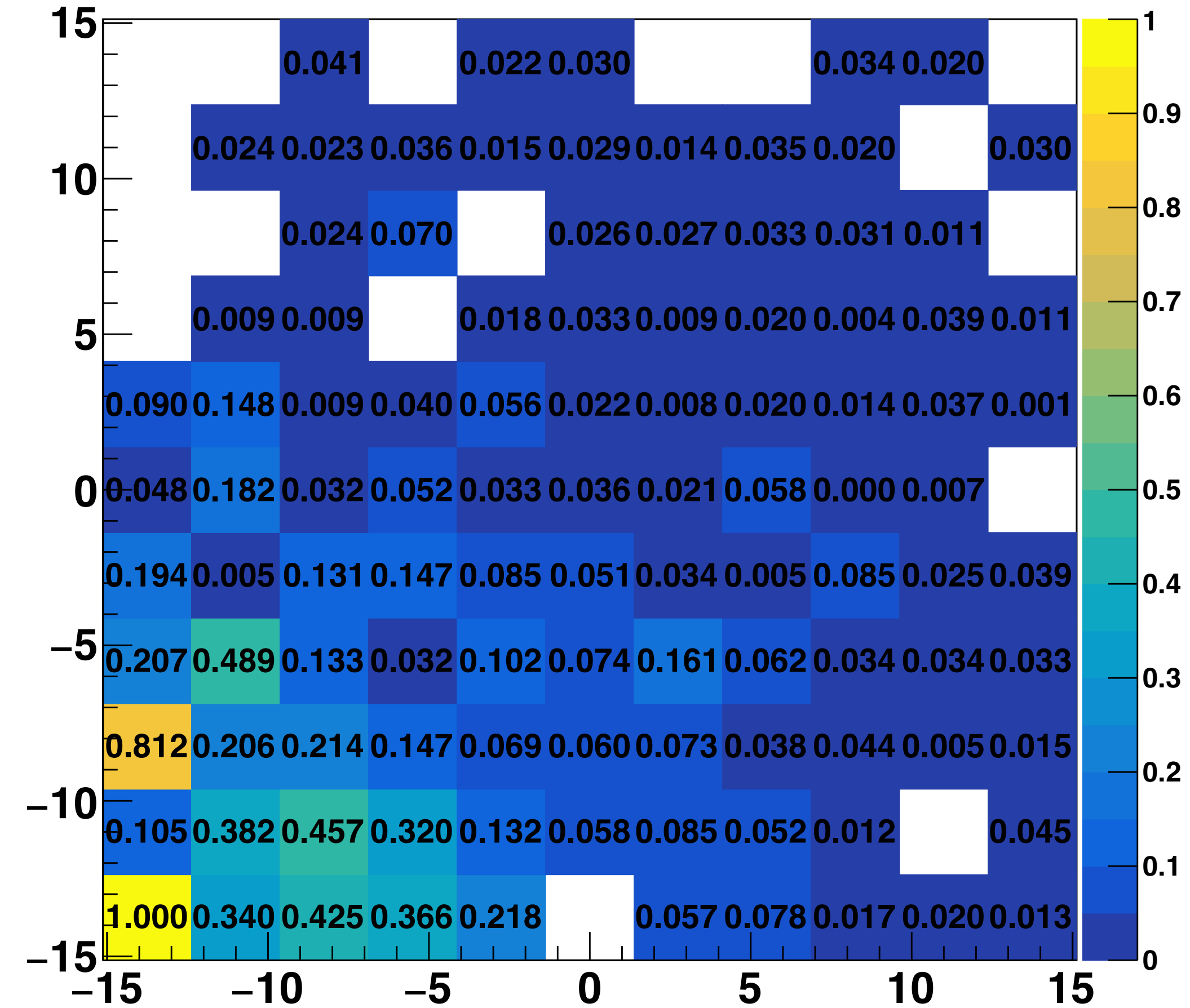

Geometry7

PMMA

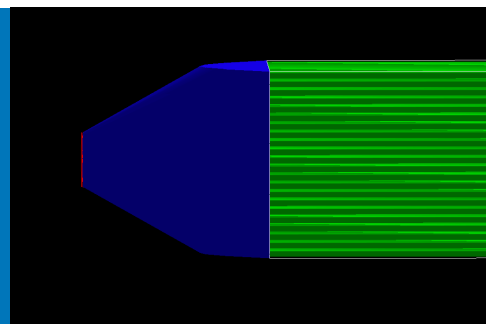

statistic 11.000 - muon 1 GeV

FISH TAIL
PMT 4.5

Efficiency - LG - PMMA - 4cm - base round - 4.5 mm

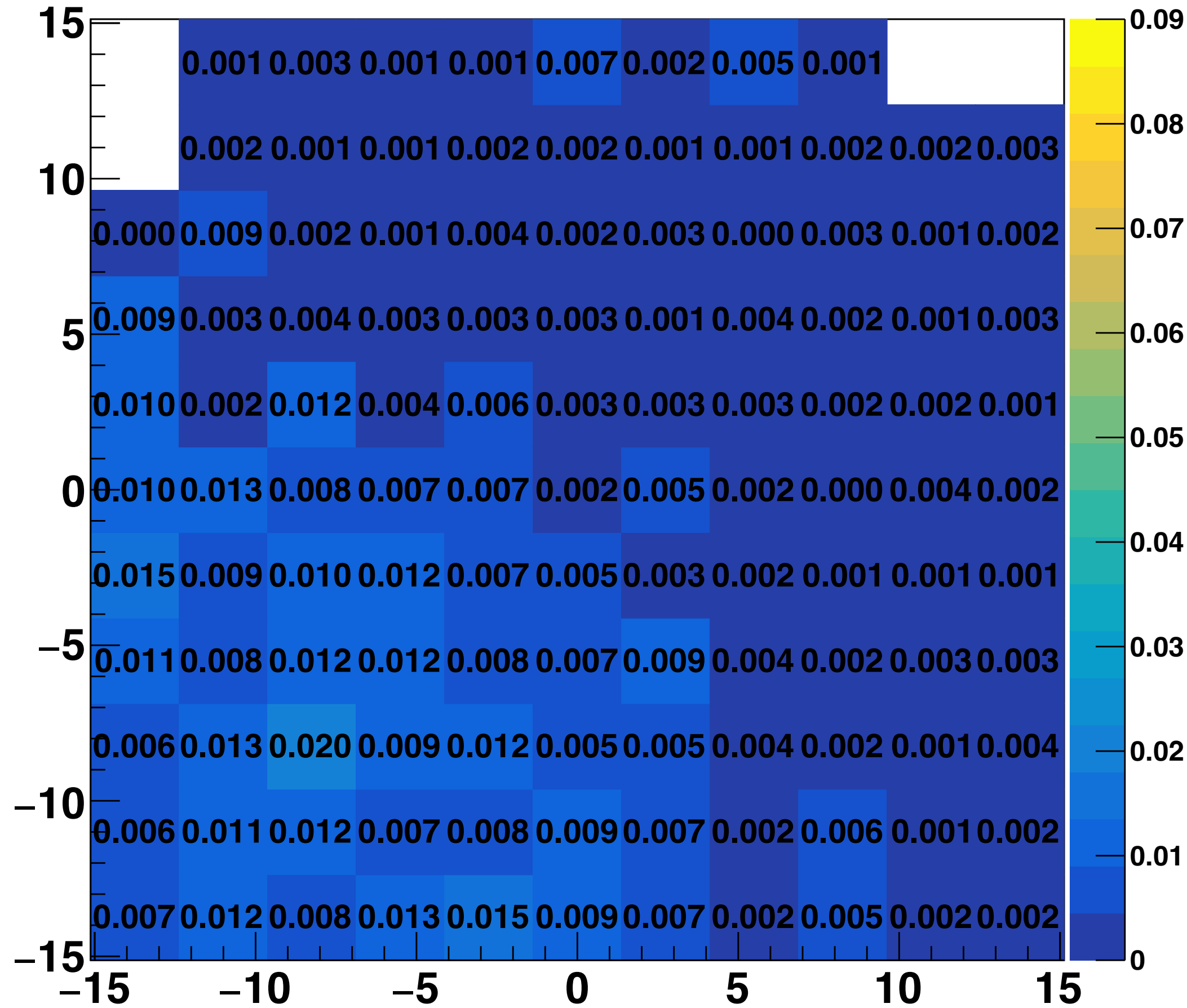

Factor non-uniformity - LG - PMMA - 4cm - base round - 4.5 mm

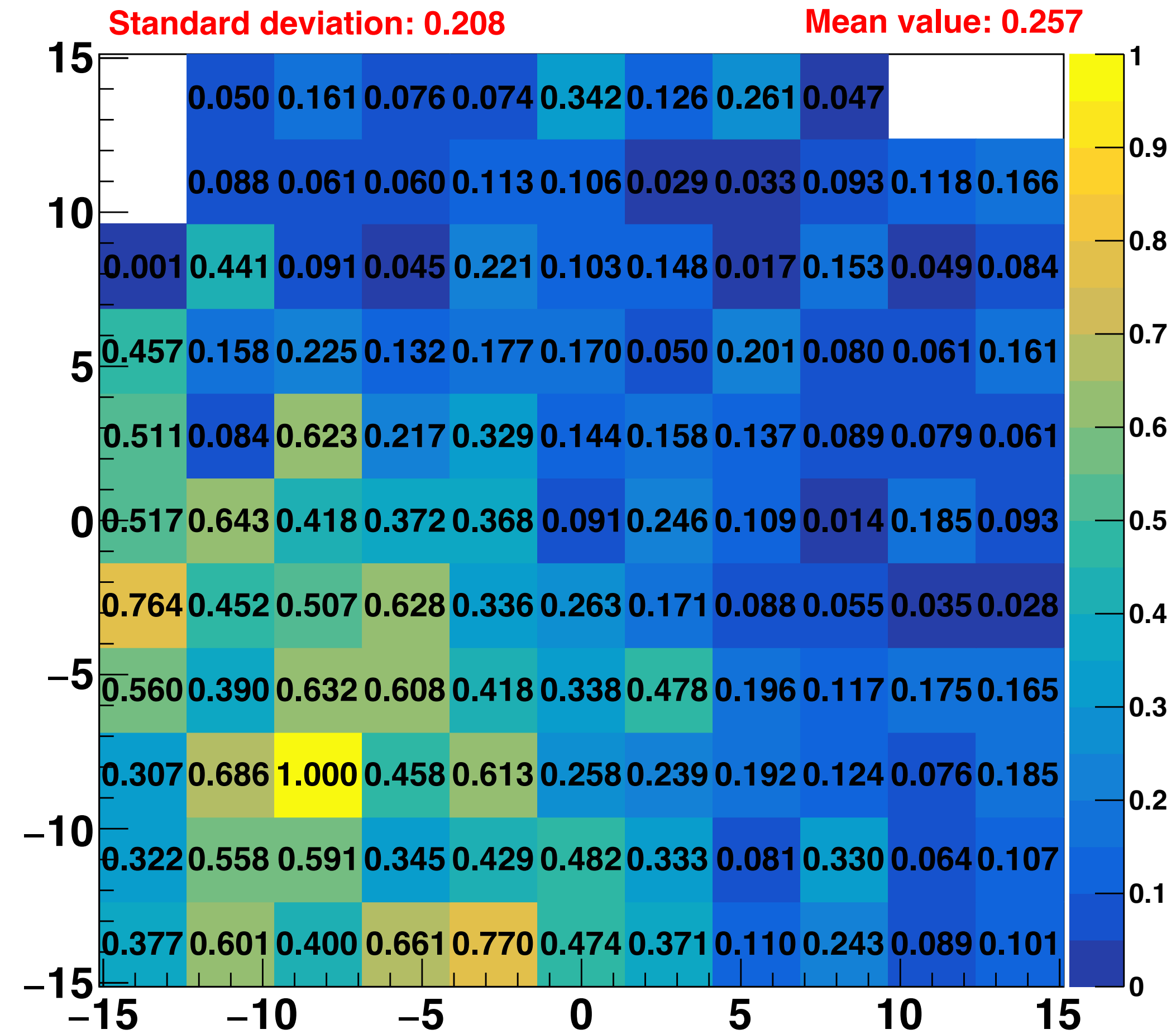

Geometry7

PMMA

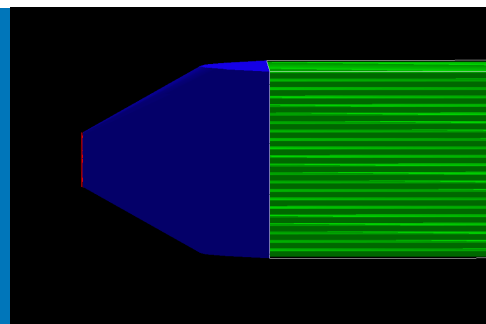

statistic 11.000 - muon 1 GeV

FISH TAIL
PMT 4.5

Efficiency - LG - PMMA - 5cm - base round - 4.5 mm

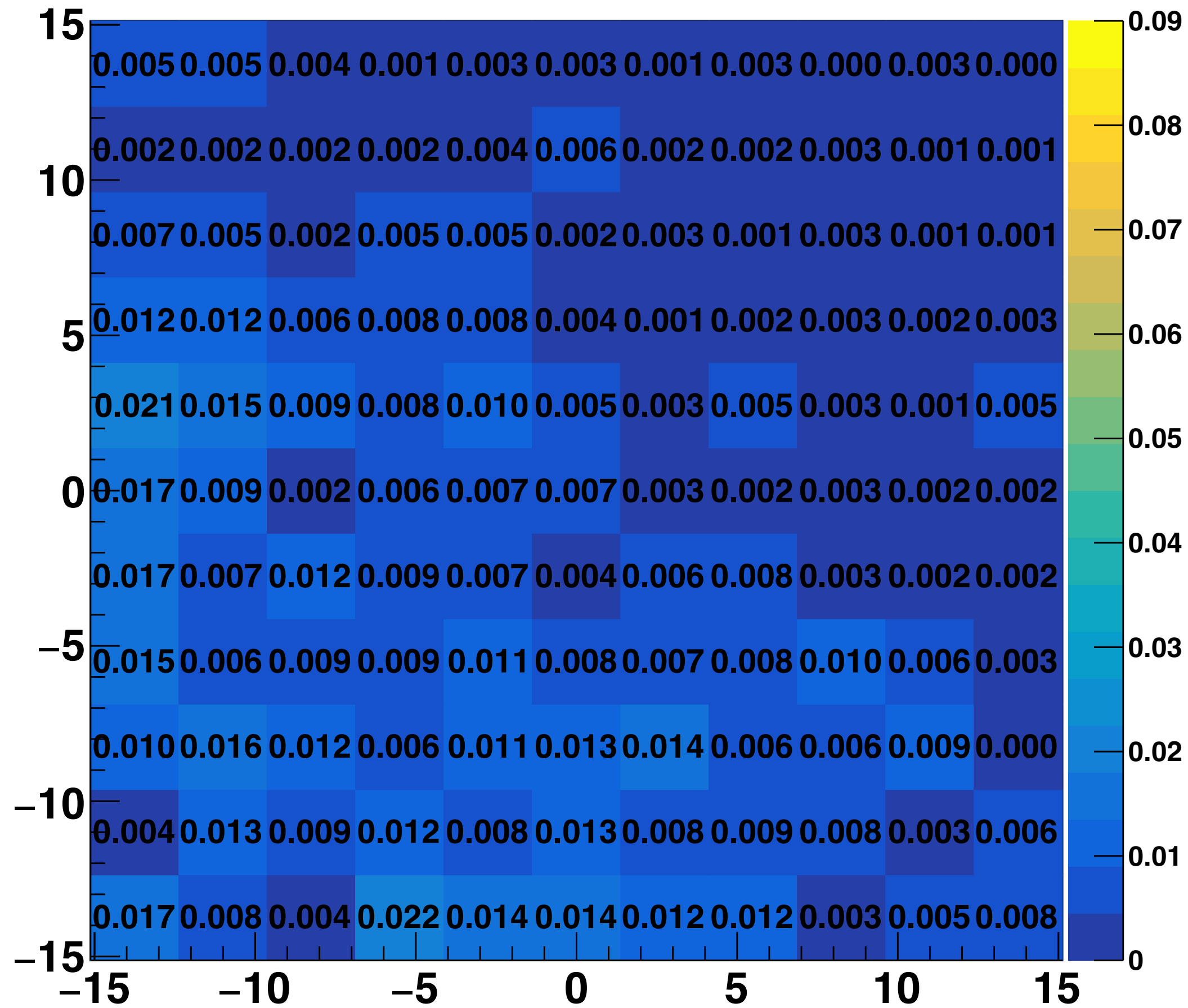

Factor non-uniformity - LG - PMMA - 5cm - base round - 4.5 mm

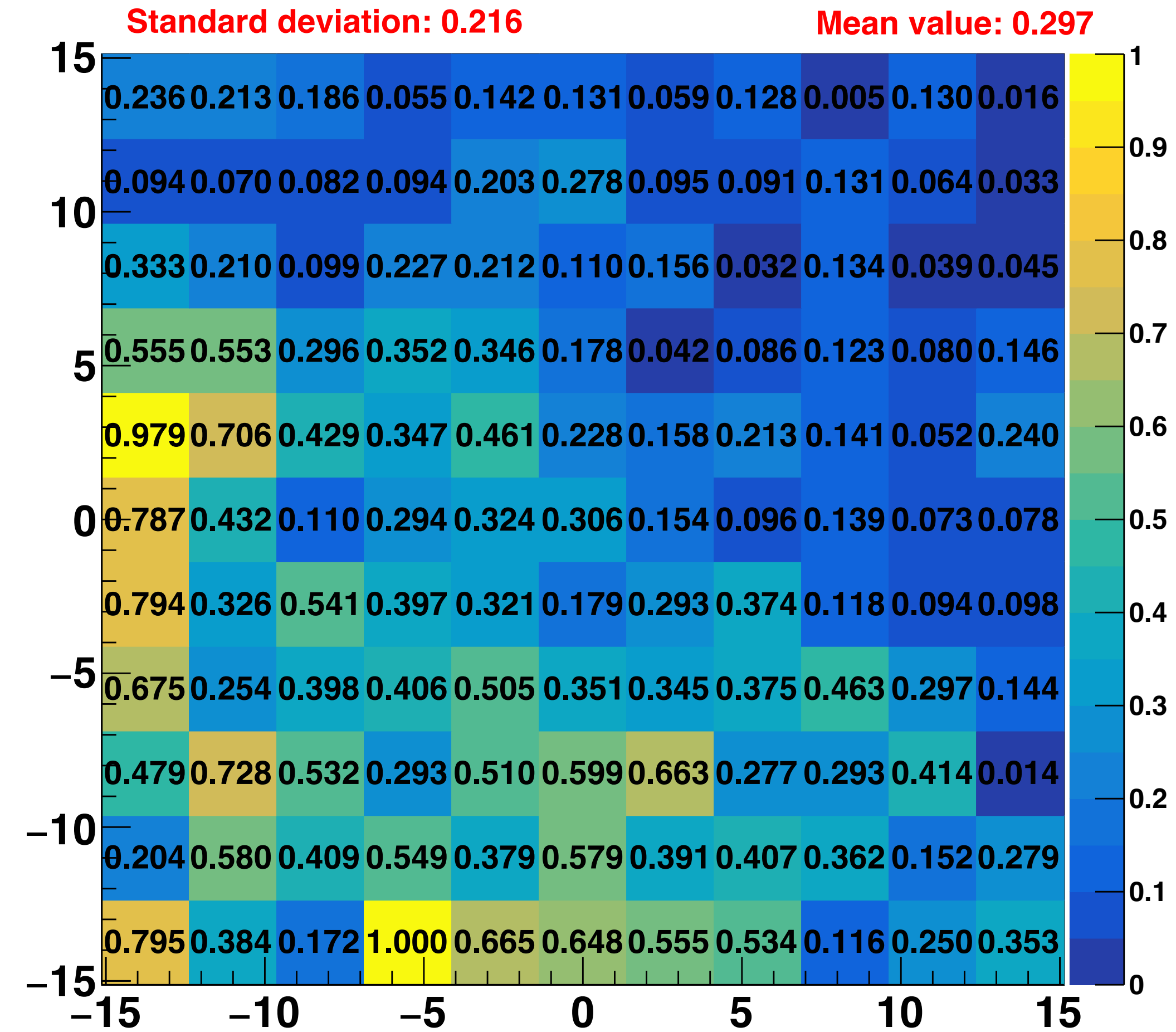

Geometry7

PMMA

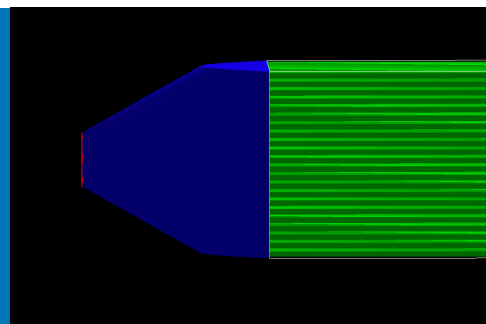

statistic 11.000 - muon 1 GeV

FISH TAIL
PMT 4.5

Efficiency - LG - PMMA - 6cm - base round - 4.5 mm

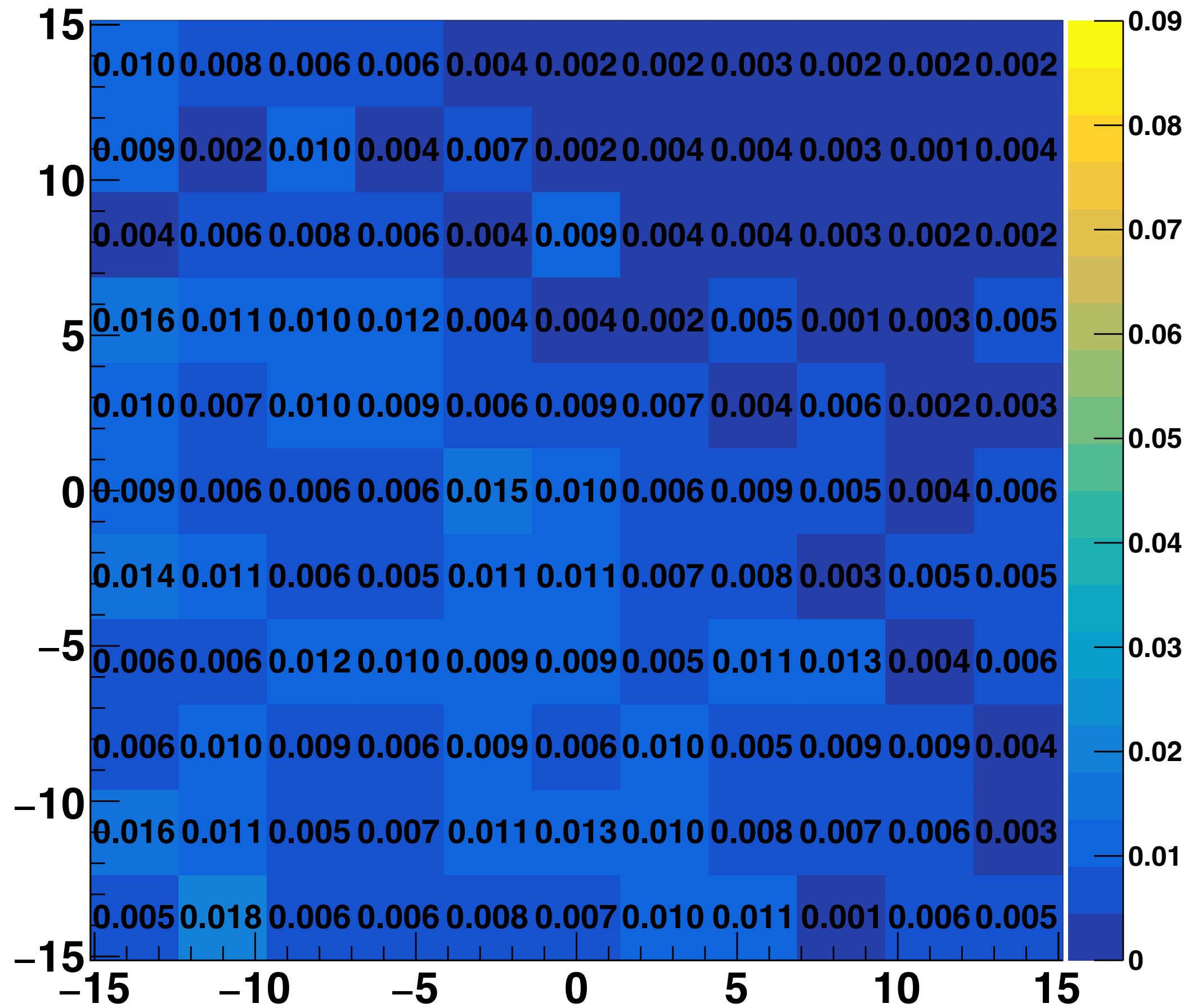

Factor non-uniformity - LG - PMMA - 6cm - base round - 4.5 mm

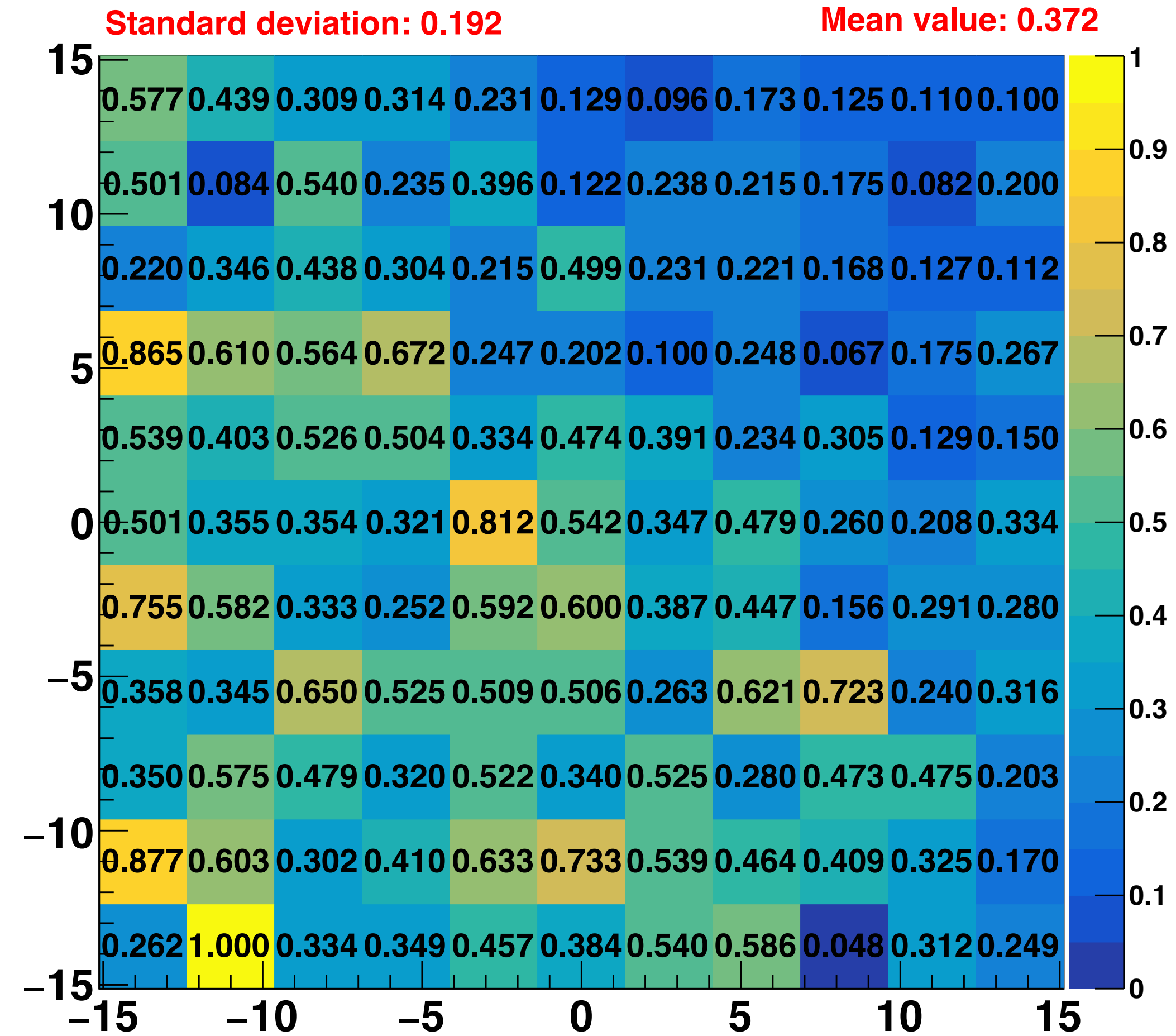

Geometry7

AIR

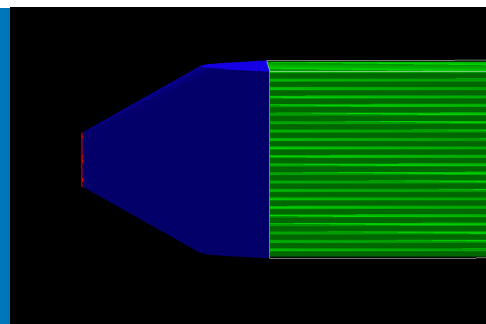

statistic 11.000 - muon 1 GeV

FISH TAIL
PMT 4.5

Efficiency - LG - Air - 2cm - base round - 4.5 mm

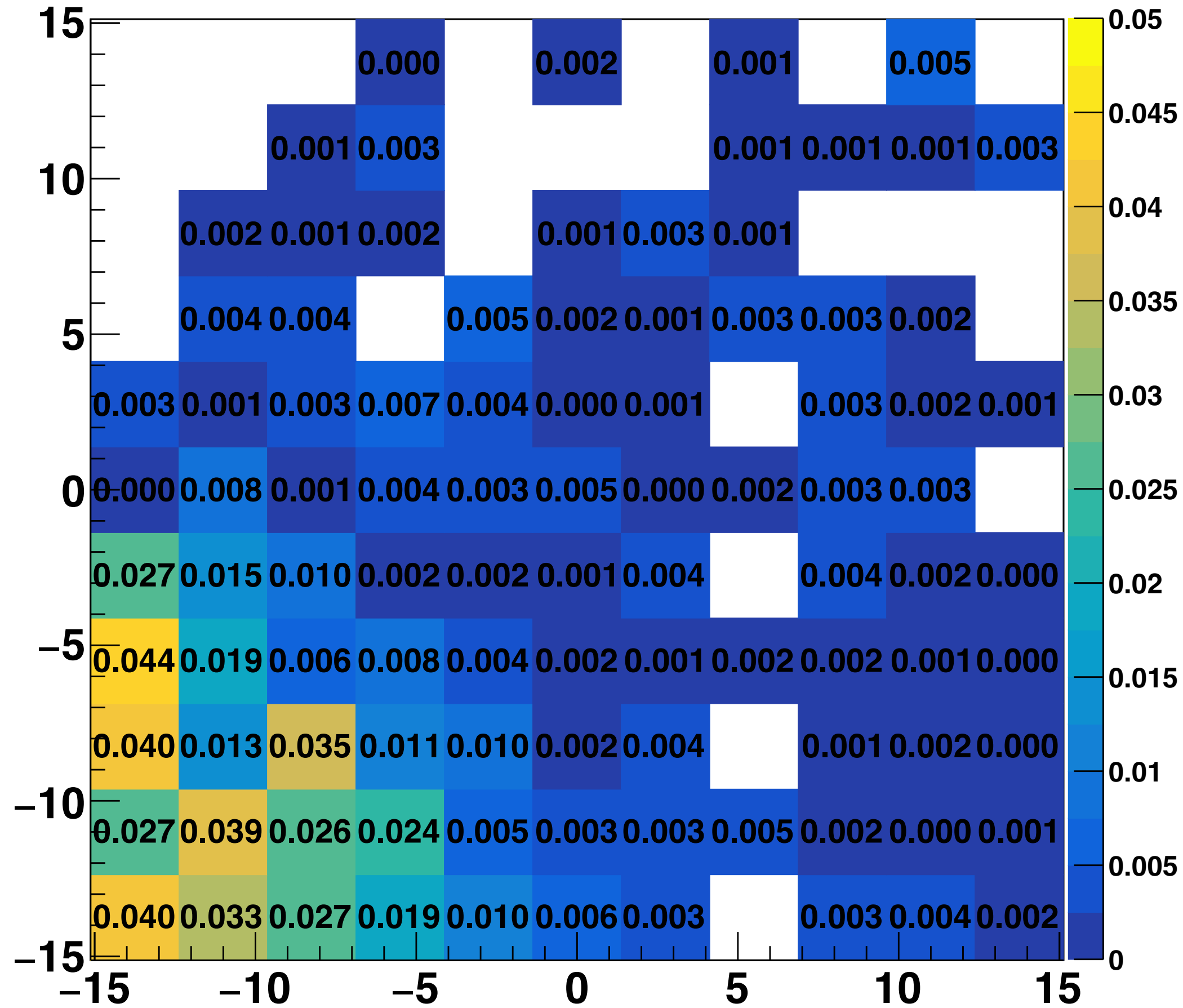

Factor non-uniformity - LG - Air - 2cm - base round - 4.5 mm

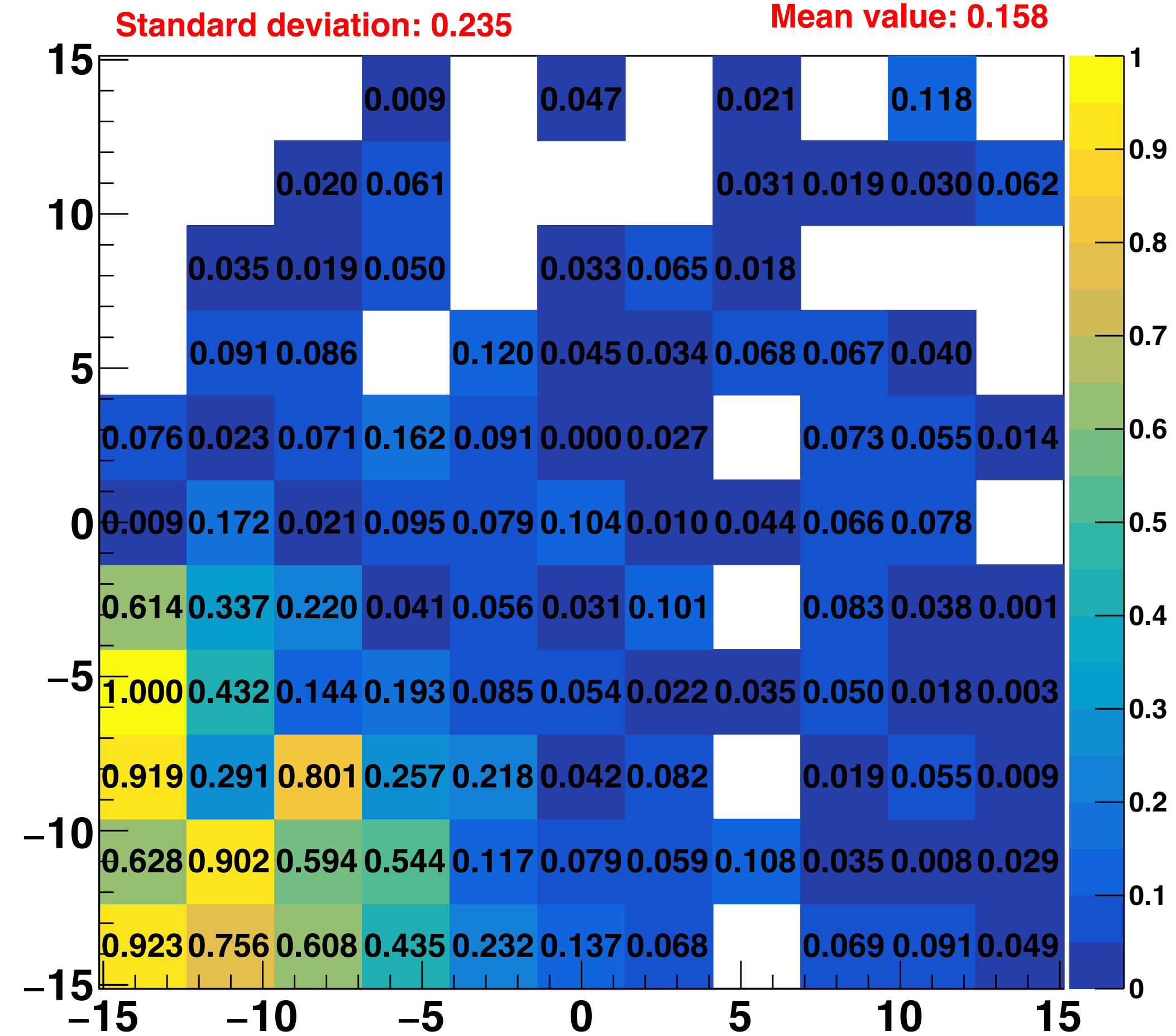

Geometry7

AIR

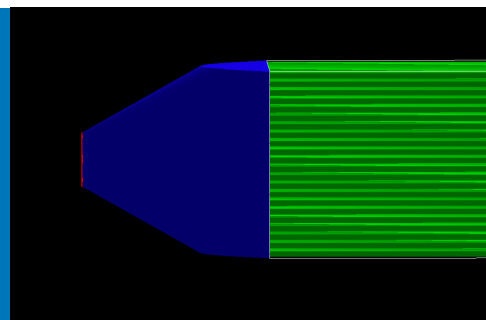

statistic 11.000 - muon 1 GeV

FISH TAIL
PMT 4.5

Efficiency - LG - Air - 3cm - base round - 4.5 mm

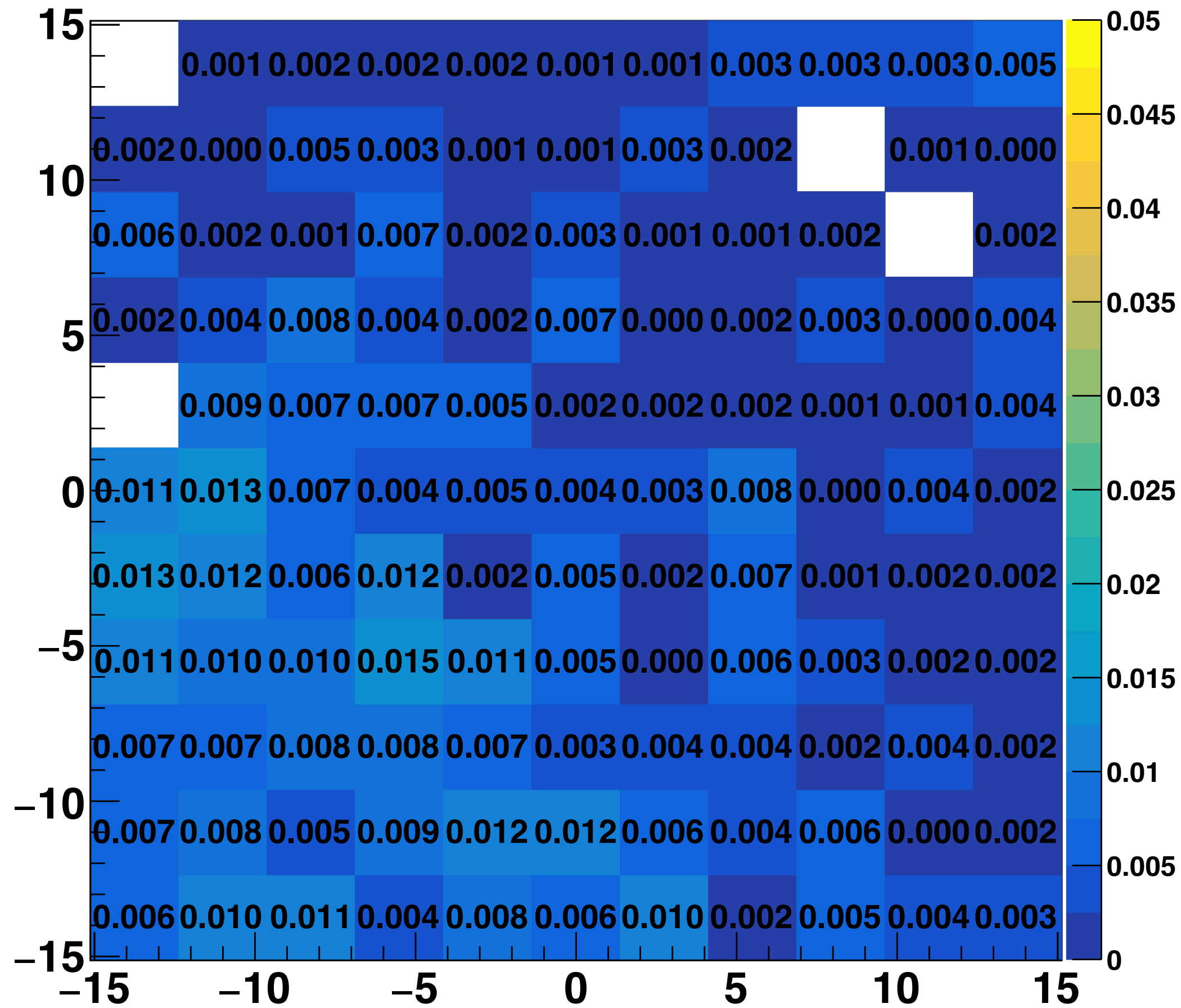

Factor non-uniformity - LG - Air - 3cm - base round - 4.5 mm

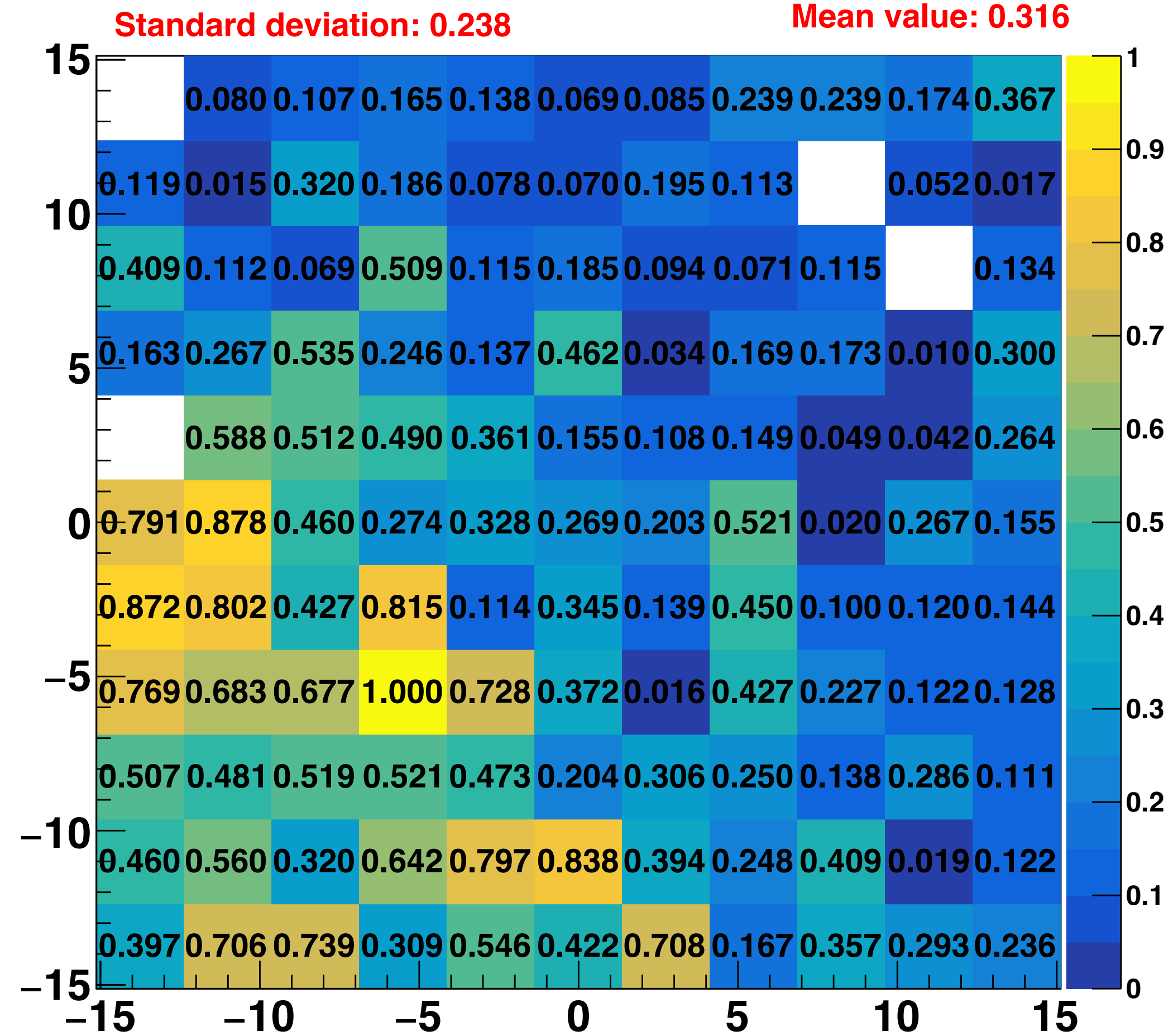

Geometry7

AIR

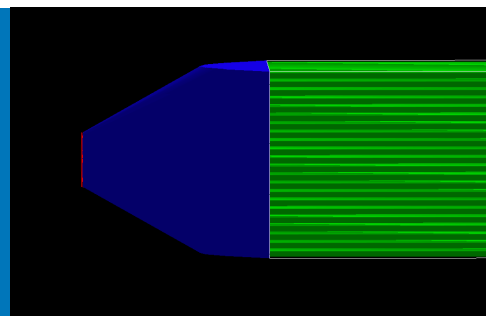

statistic 11.000 - muon 1 GeV

FISH TAIL
PMT 4.5

Efficiency - LG - Air - 4cm - base round - 4.5 mm

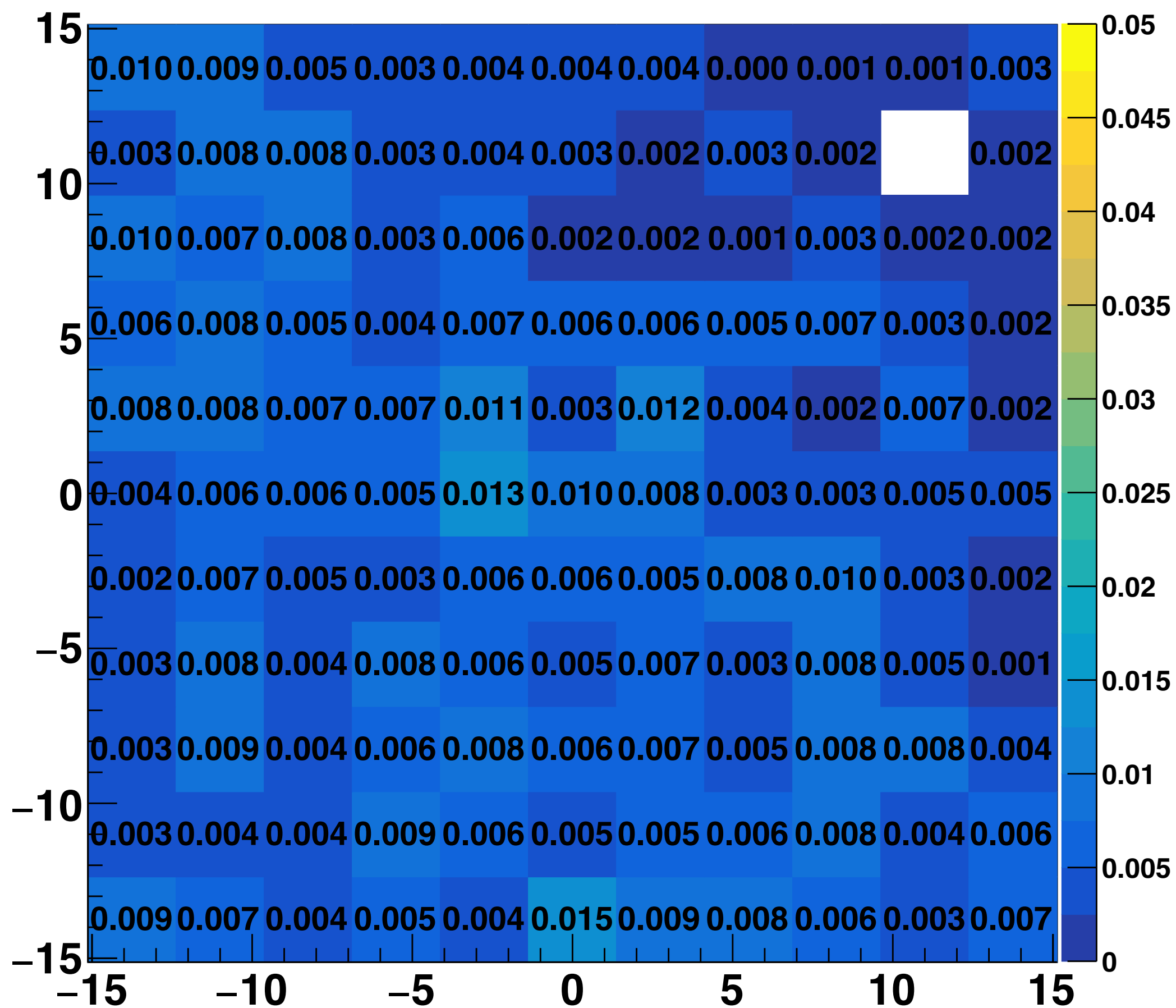

Factor non-uniformity - LG - Air - 4cm - base round - 4.5 mm

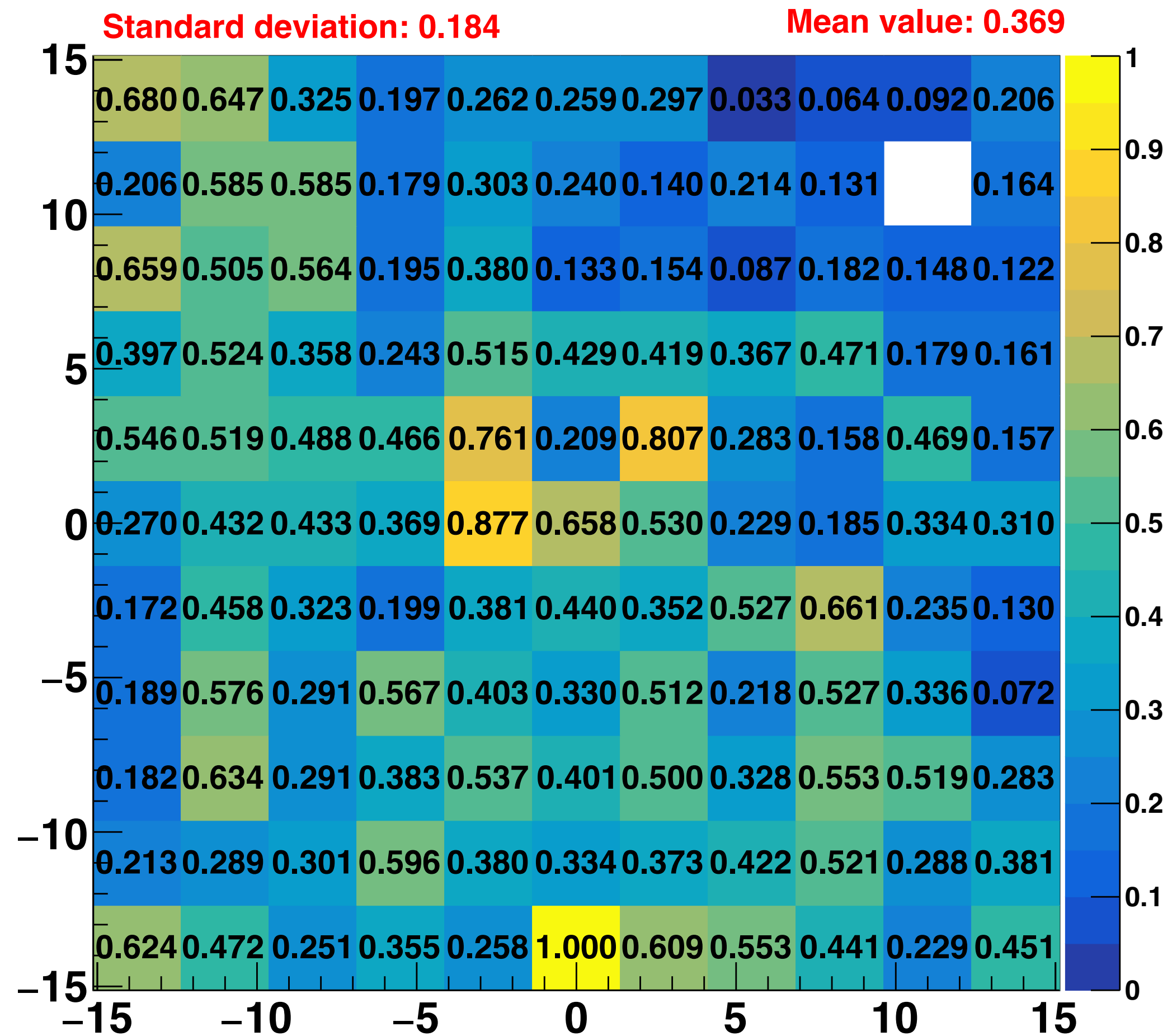

Geometry7

AIR

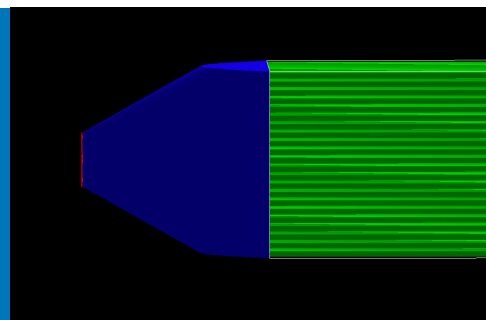

statistic 11.000 - muon 1 GeV

FISH TAIL
PMT 4.5

Efficiency - LG - Air - 5cm - base round - 4.5 mm

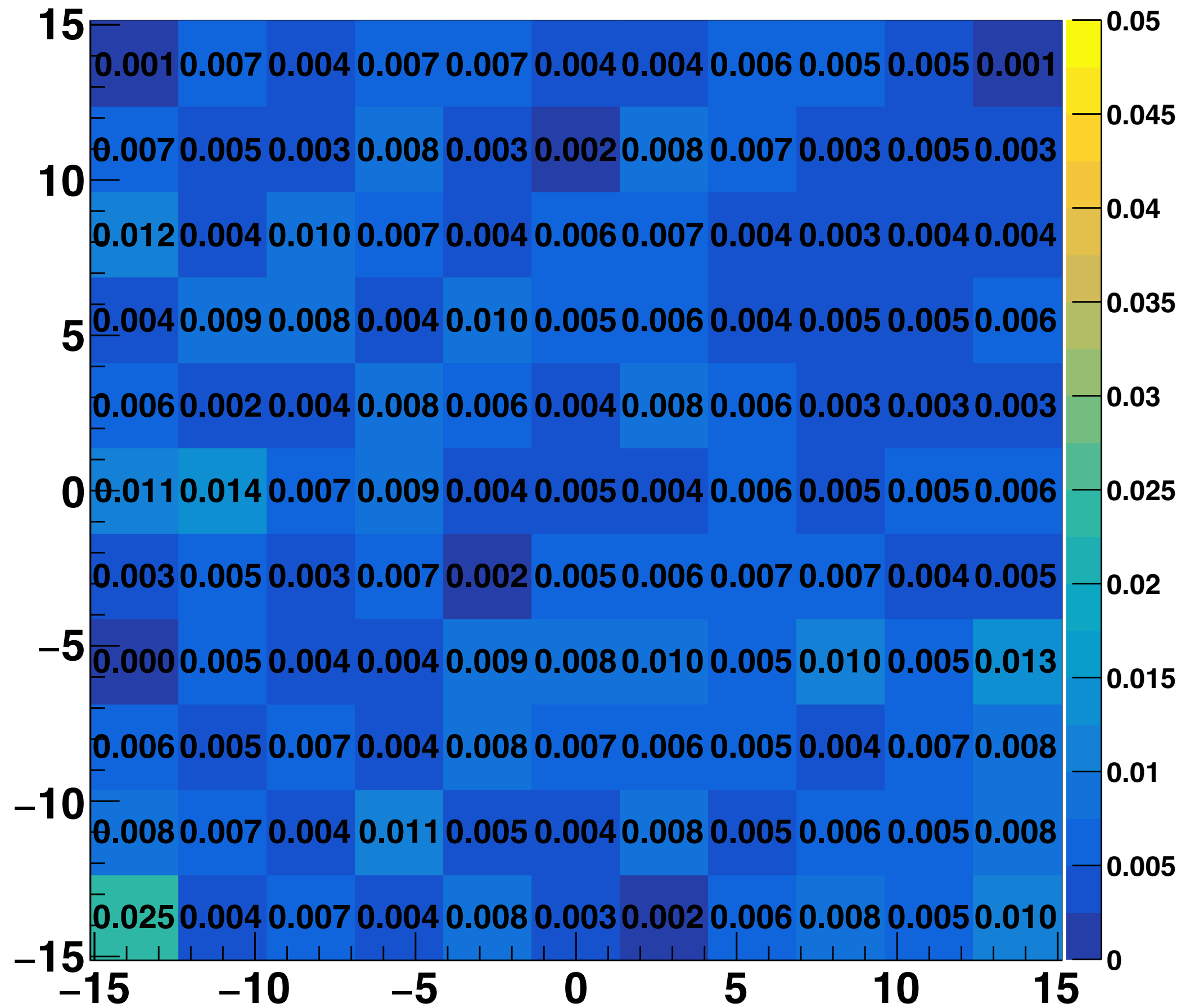

Factor non-uniformity - LG - Air - 5cm - base round - 4.5 mm

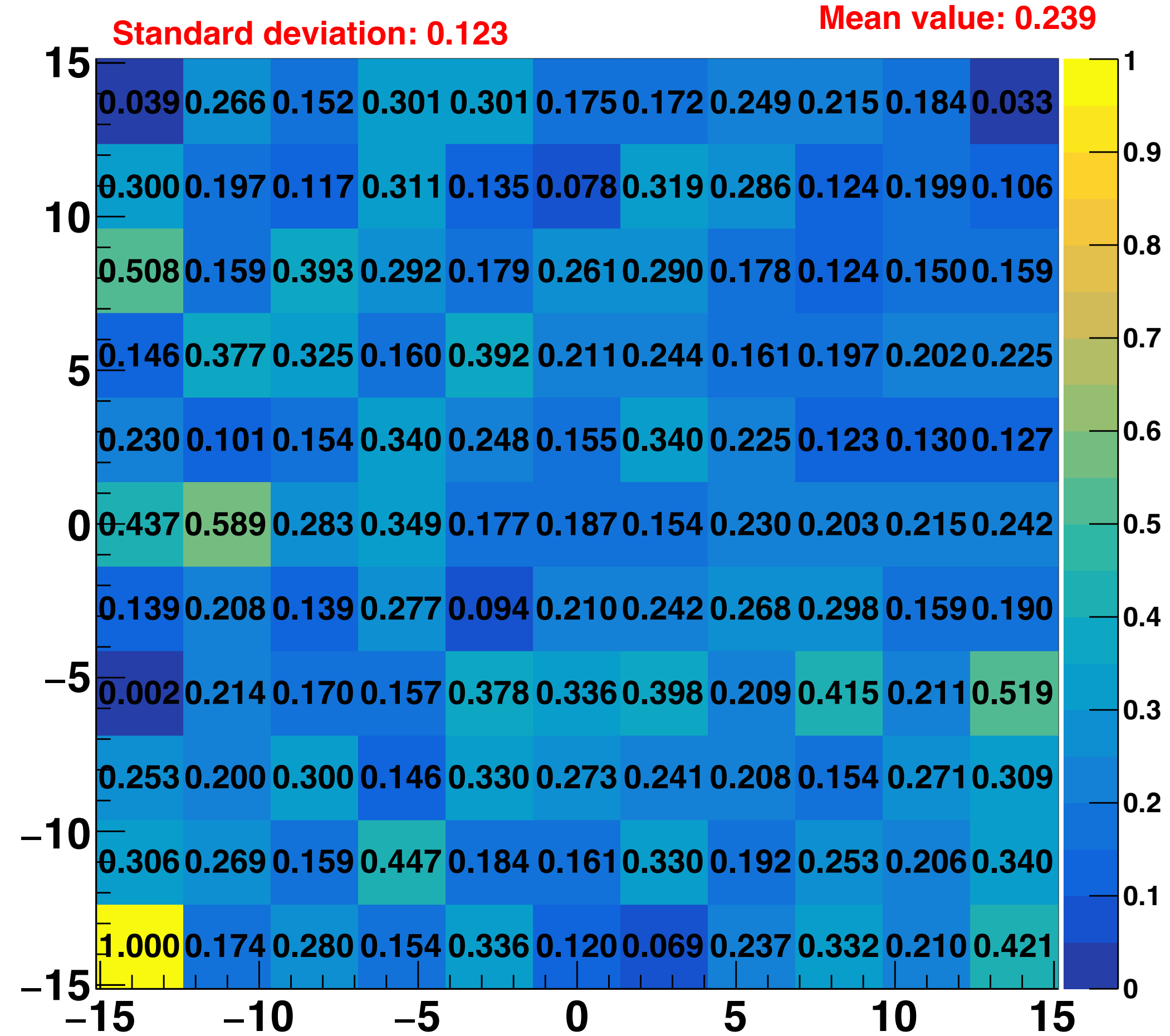

Geometry7

AIR

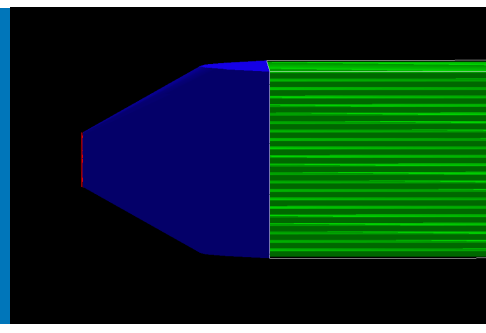

statistic 11.000 - muon 1 GeV

FISH TAIL
PMT 4.5

Efficiency - LG - Air - 6cm - base round - 4.5 mm

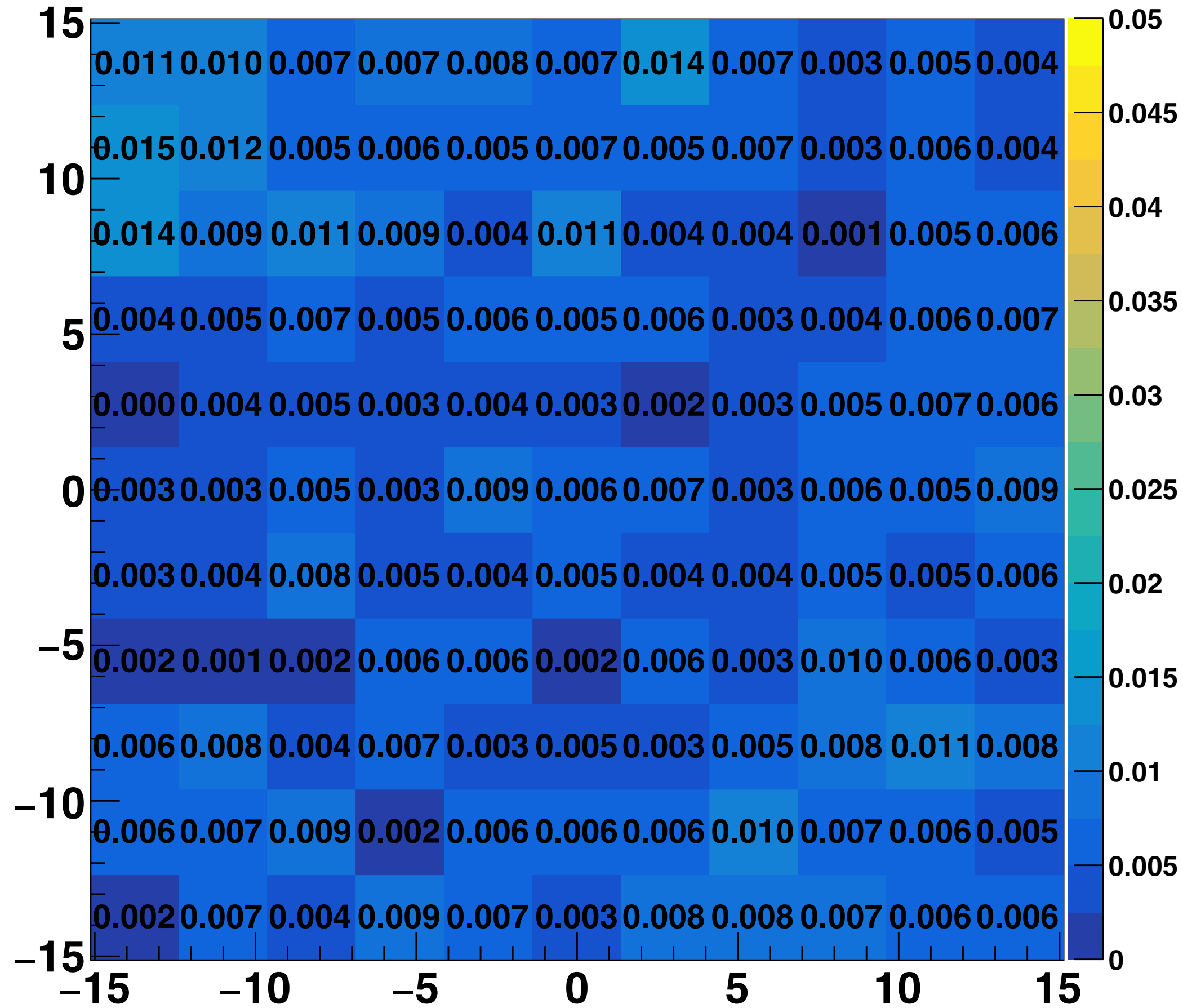

Factor non-uniformity - LG - Air - 6cm - base round - 4.5 mm

Standard deviation: 0.184

Mean value: 0.393

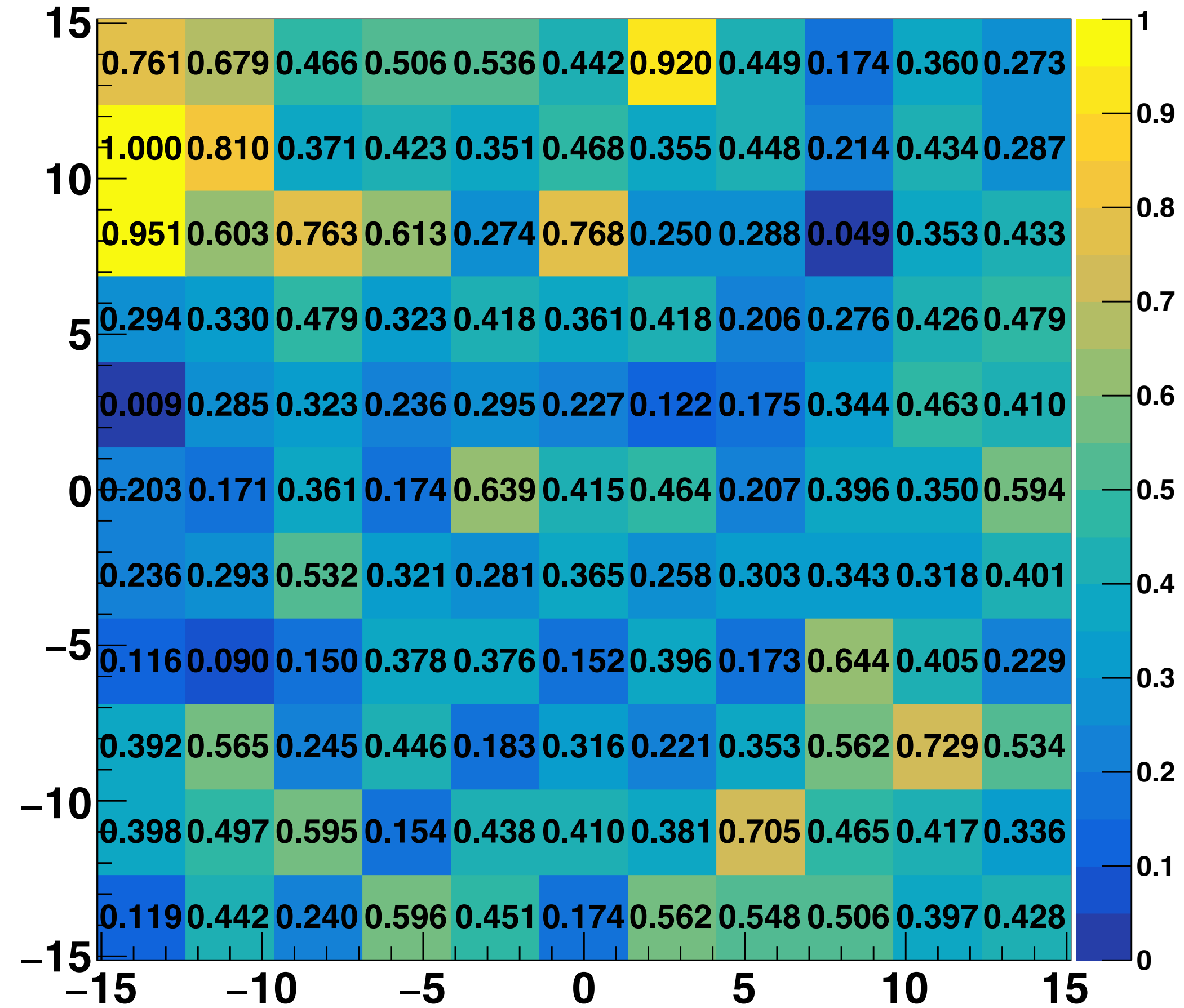

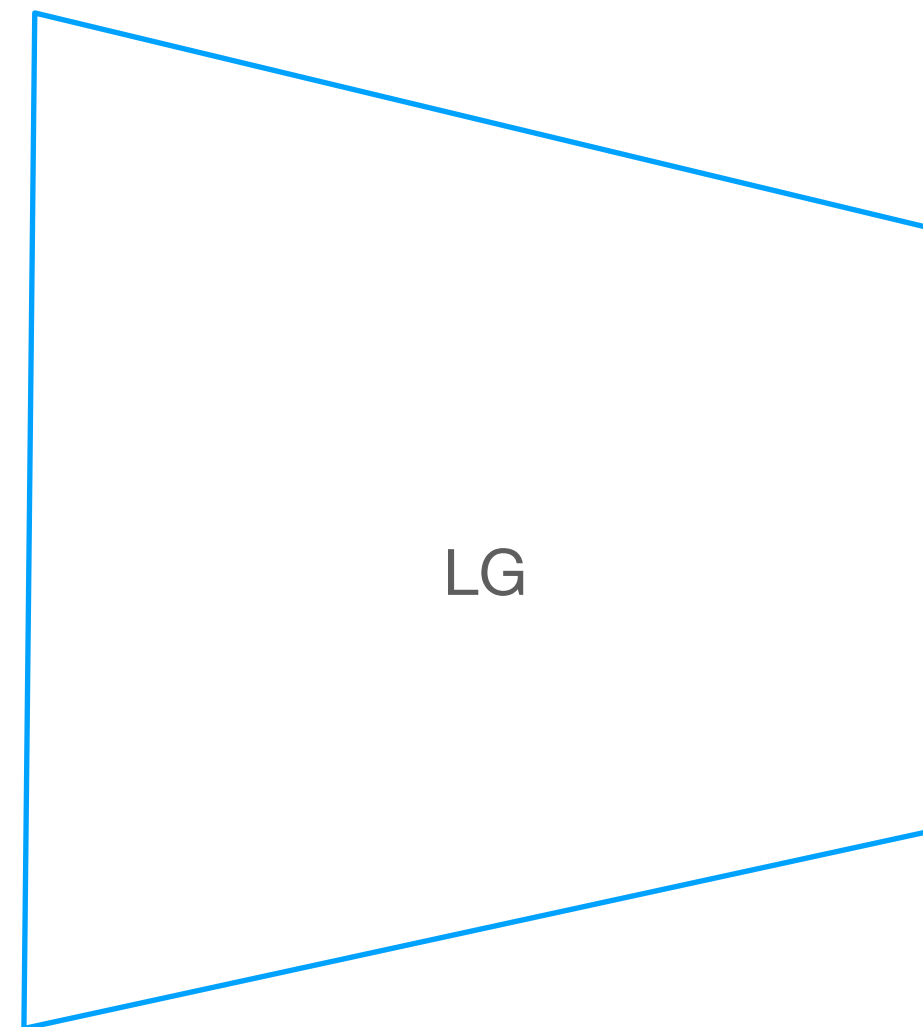
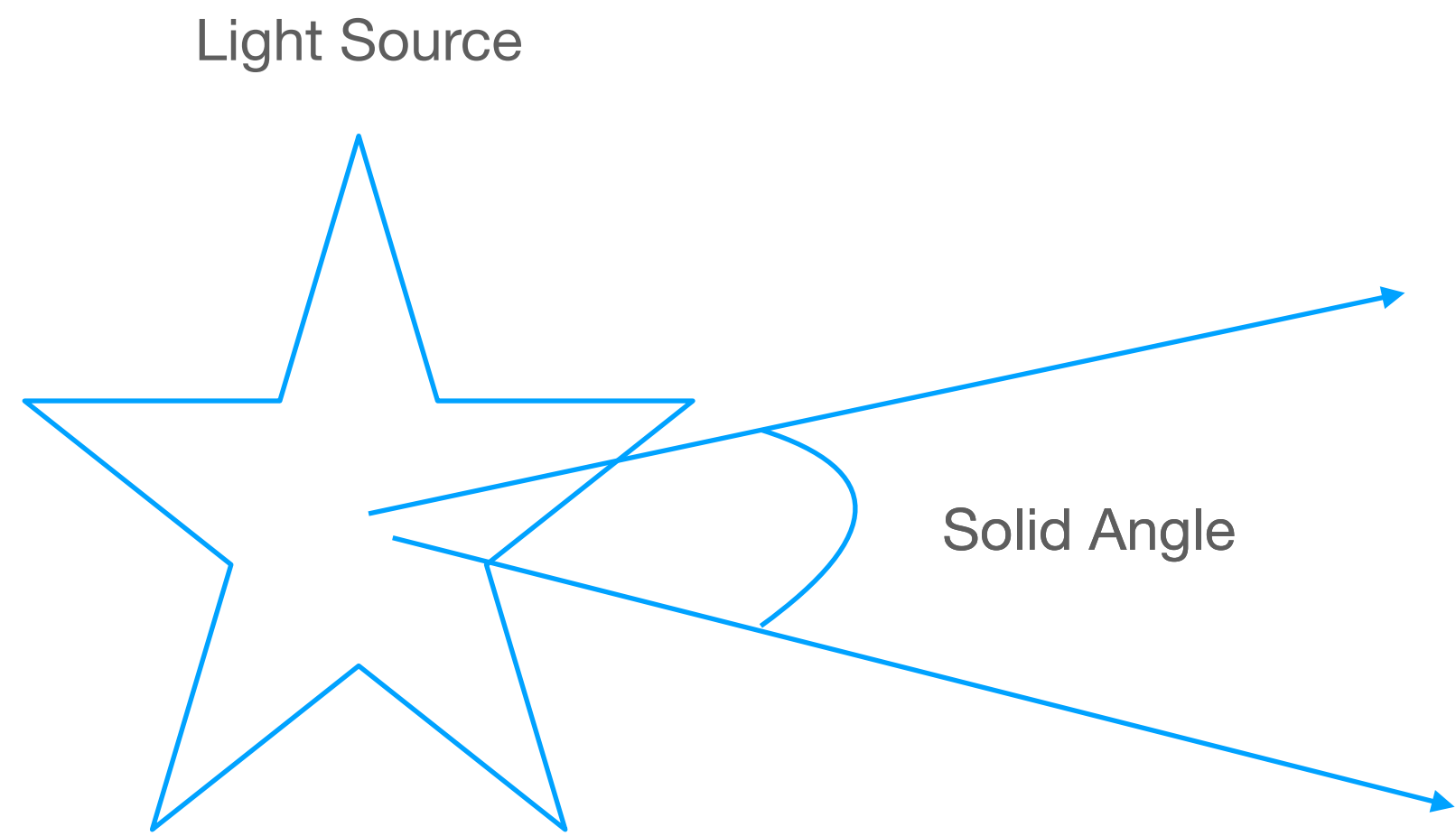

VARY?

OLD

• Geometry 6

PMMA

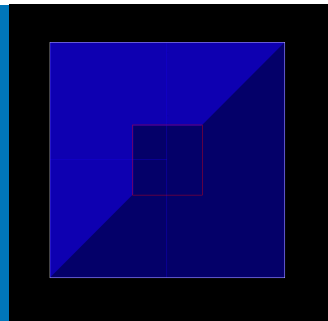

22x22 – Trap – 18 mm

Efficiency - LG - PMMA - 2cm - 22x22 - 18. mm

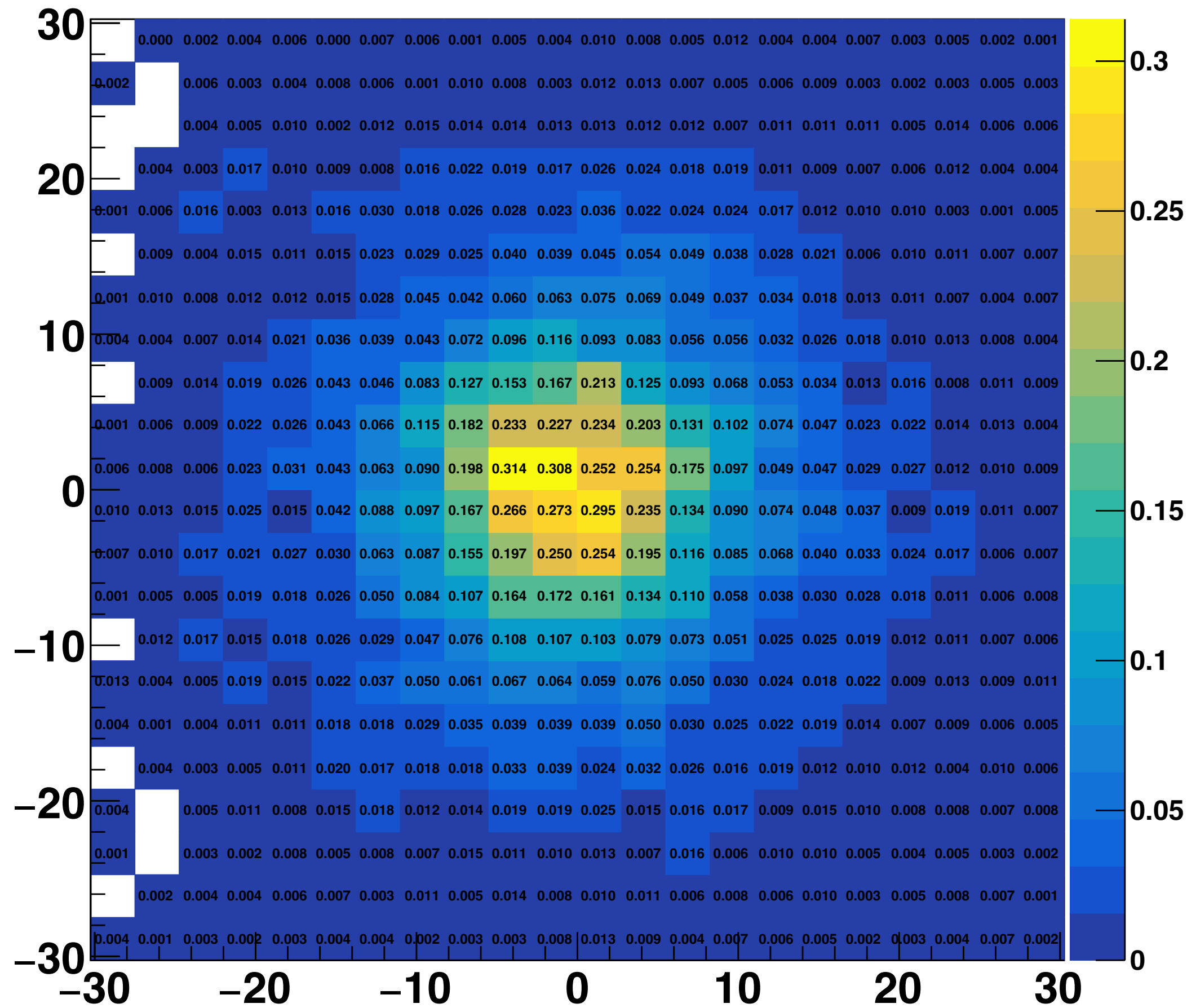

Factor non-uniformity - LG - PMMA - 2cm - 22x22 - 18. mm

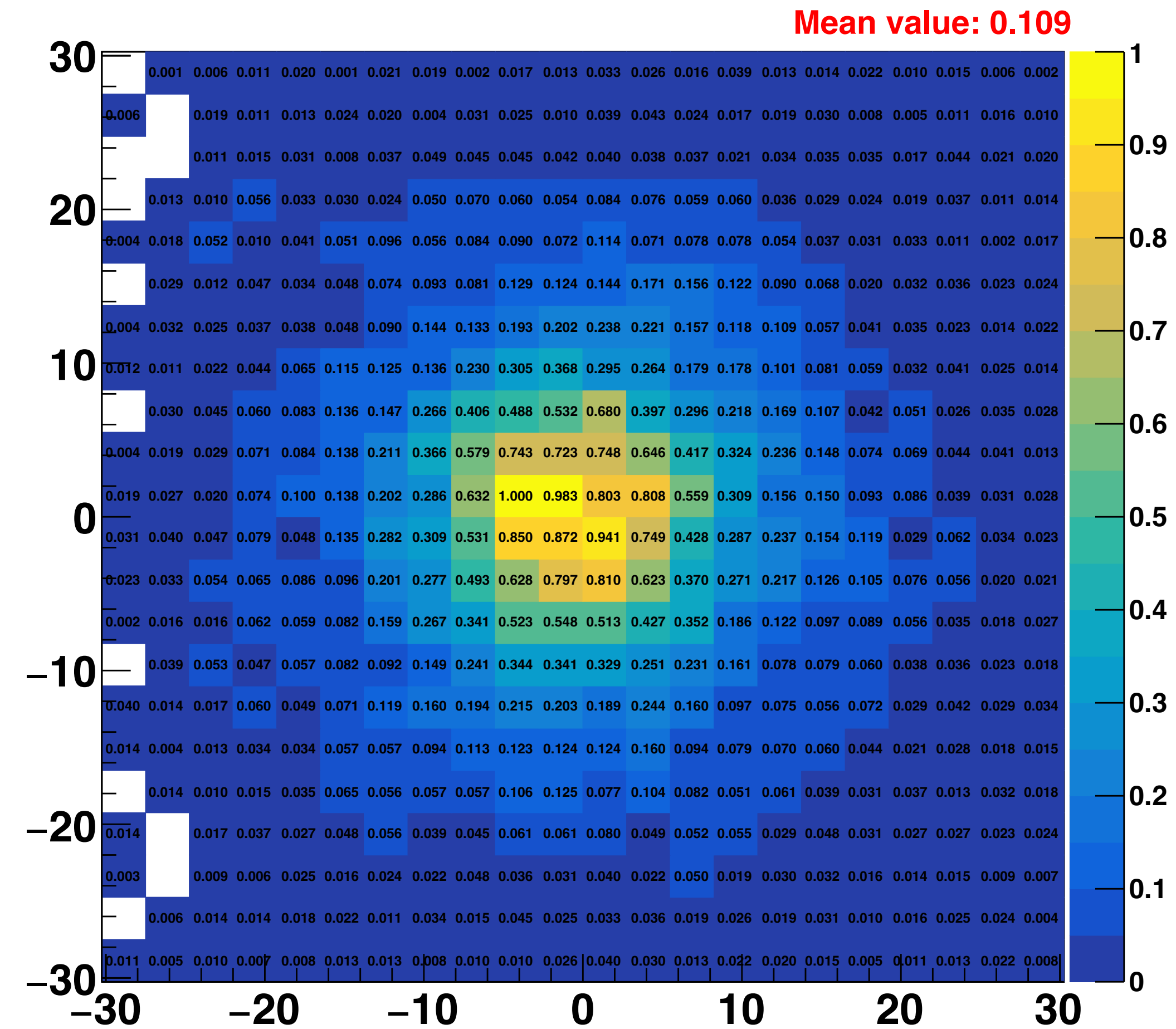

• Geometry 6

PMMA

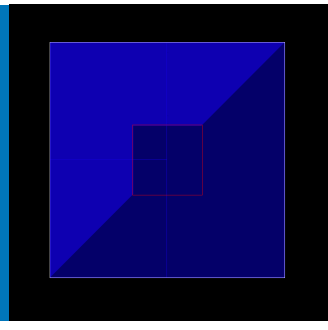

22x22 – Trap – 18 mm

Efficiency - LG - PMMA - 3cm - 22x22 - 18. mm

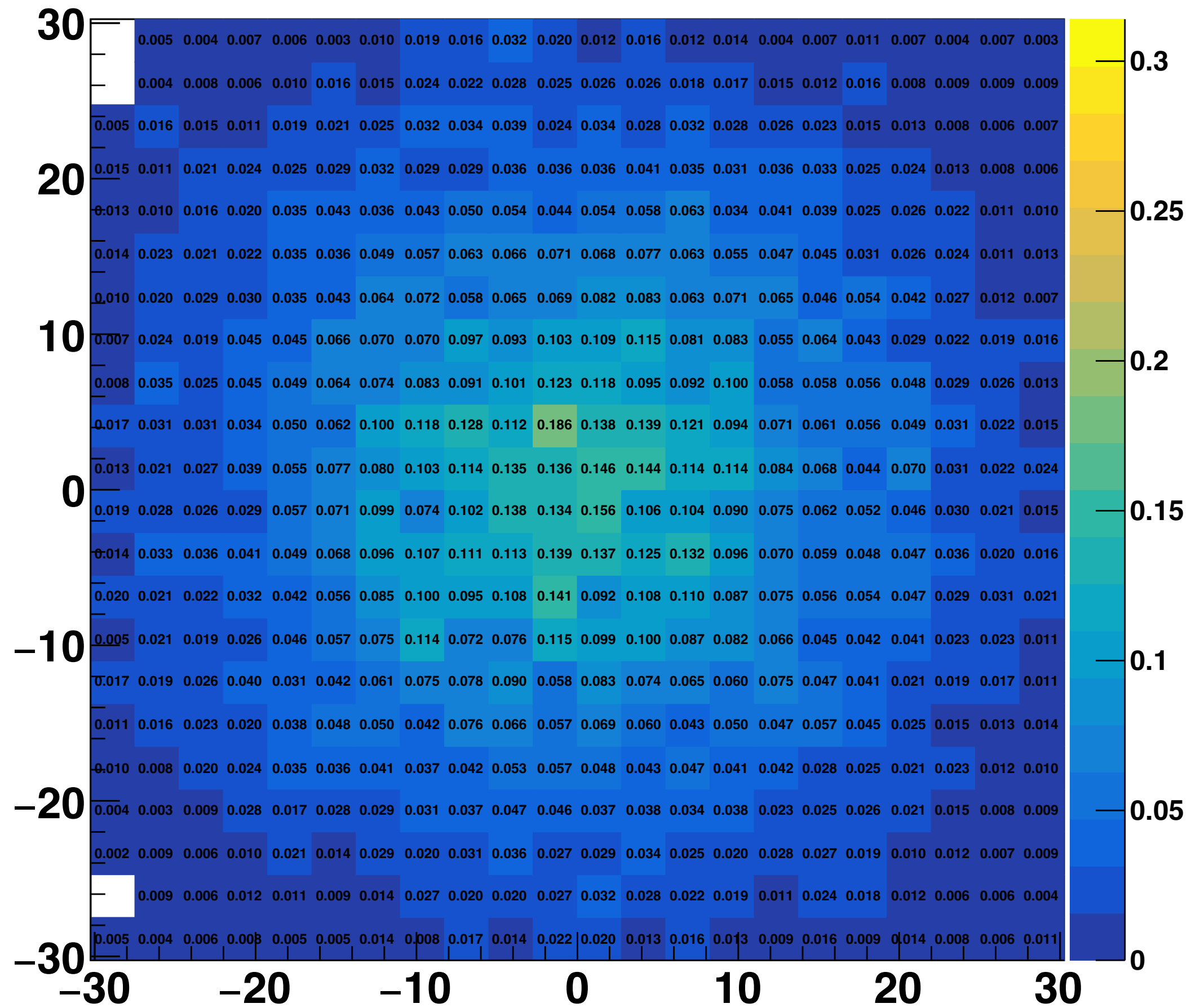

Factor non-uniformity - LG - PMMA - 3cm - 22x22 - 18. mm

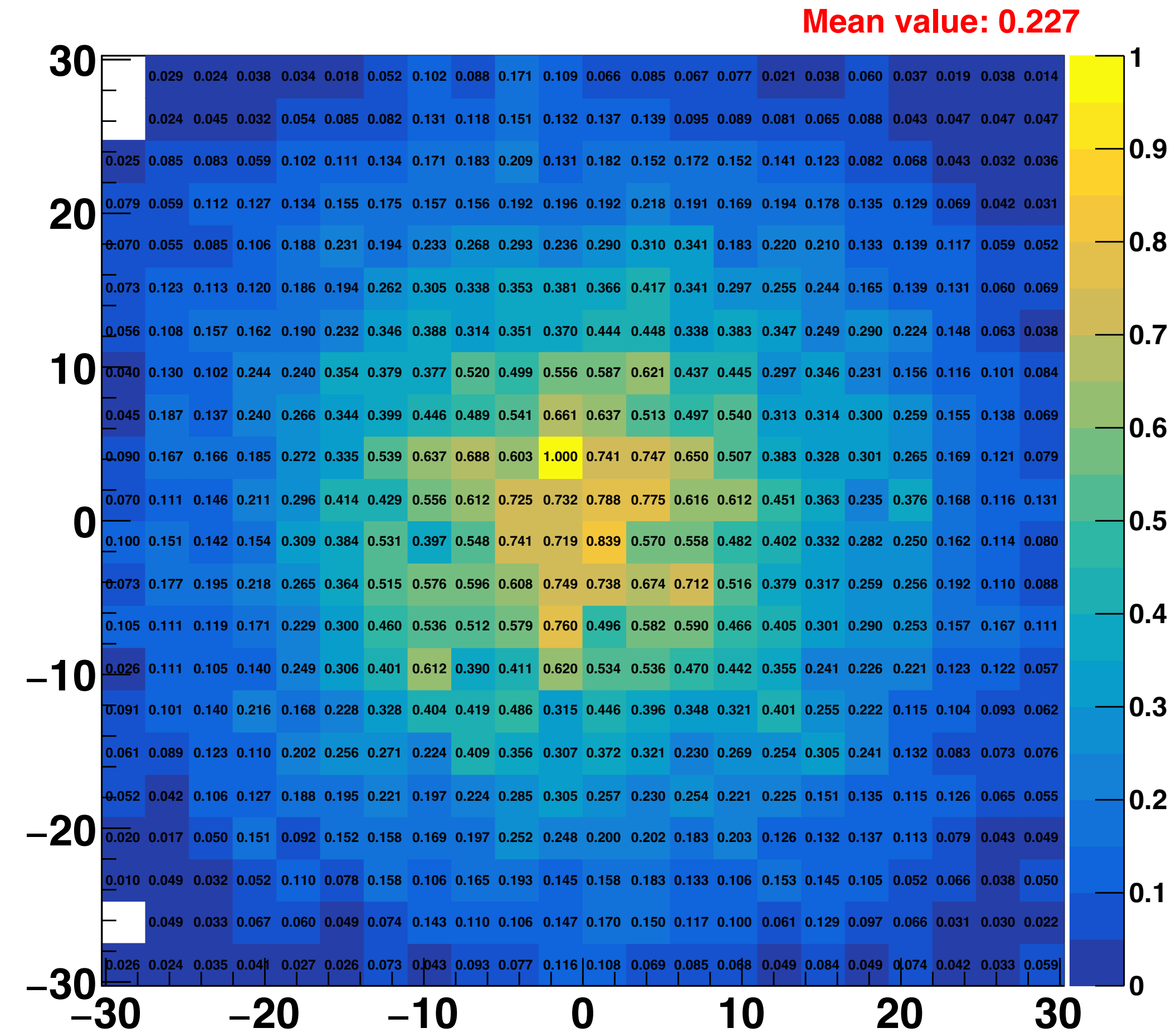

Geometry 6

PMMA

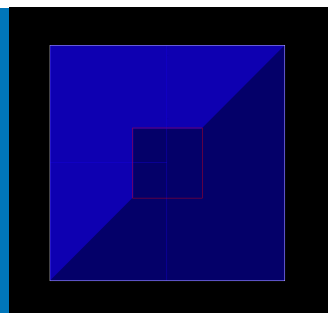

22x22 – Trap – 18 mm

Efficiency - LG - PMMA - 4cm - 22x22 - 18. mm

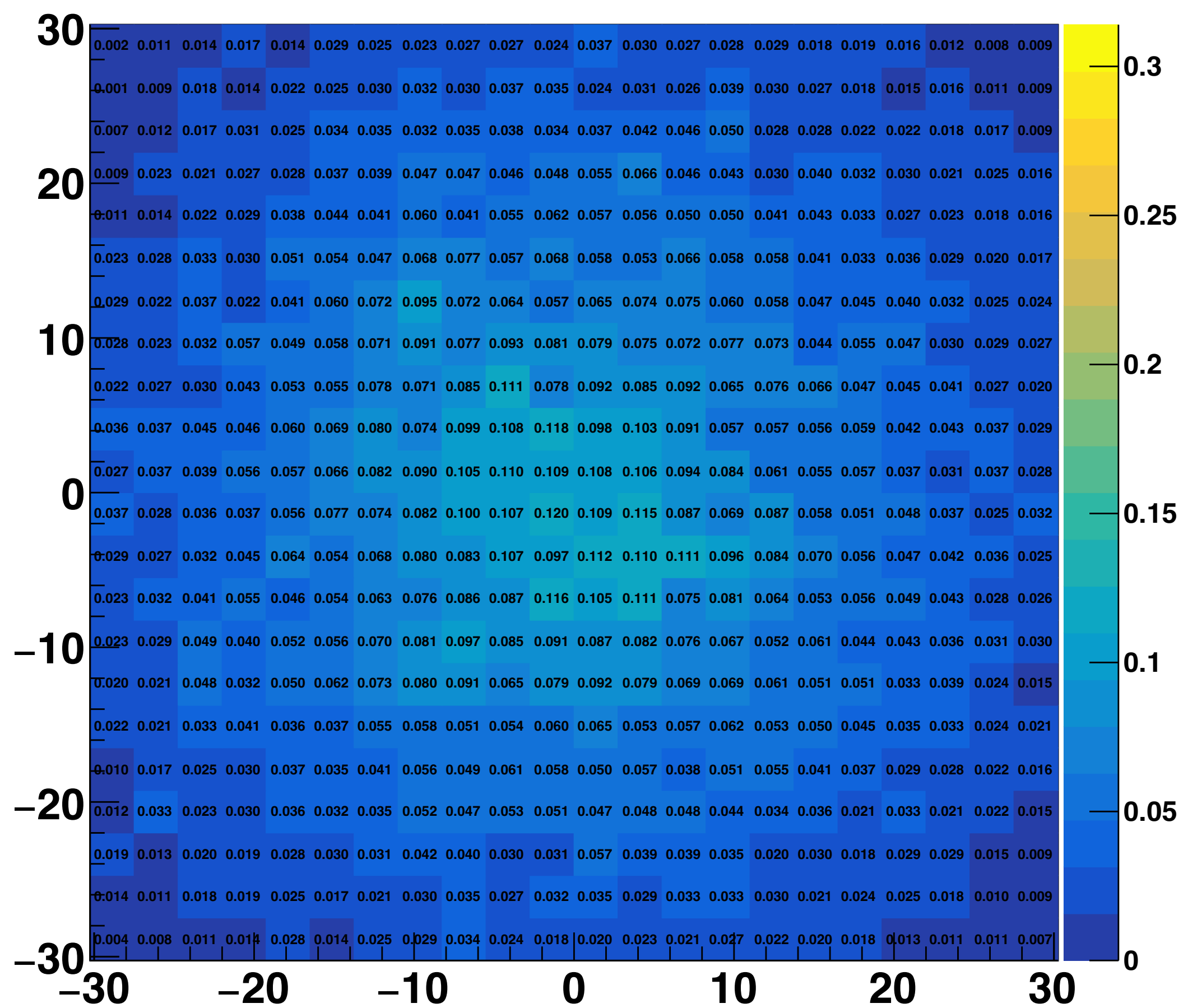

Factor non-uniformity - LG - PMMA - 4cm - 22x22 - 18. mm

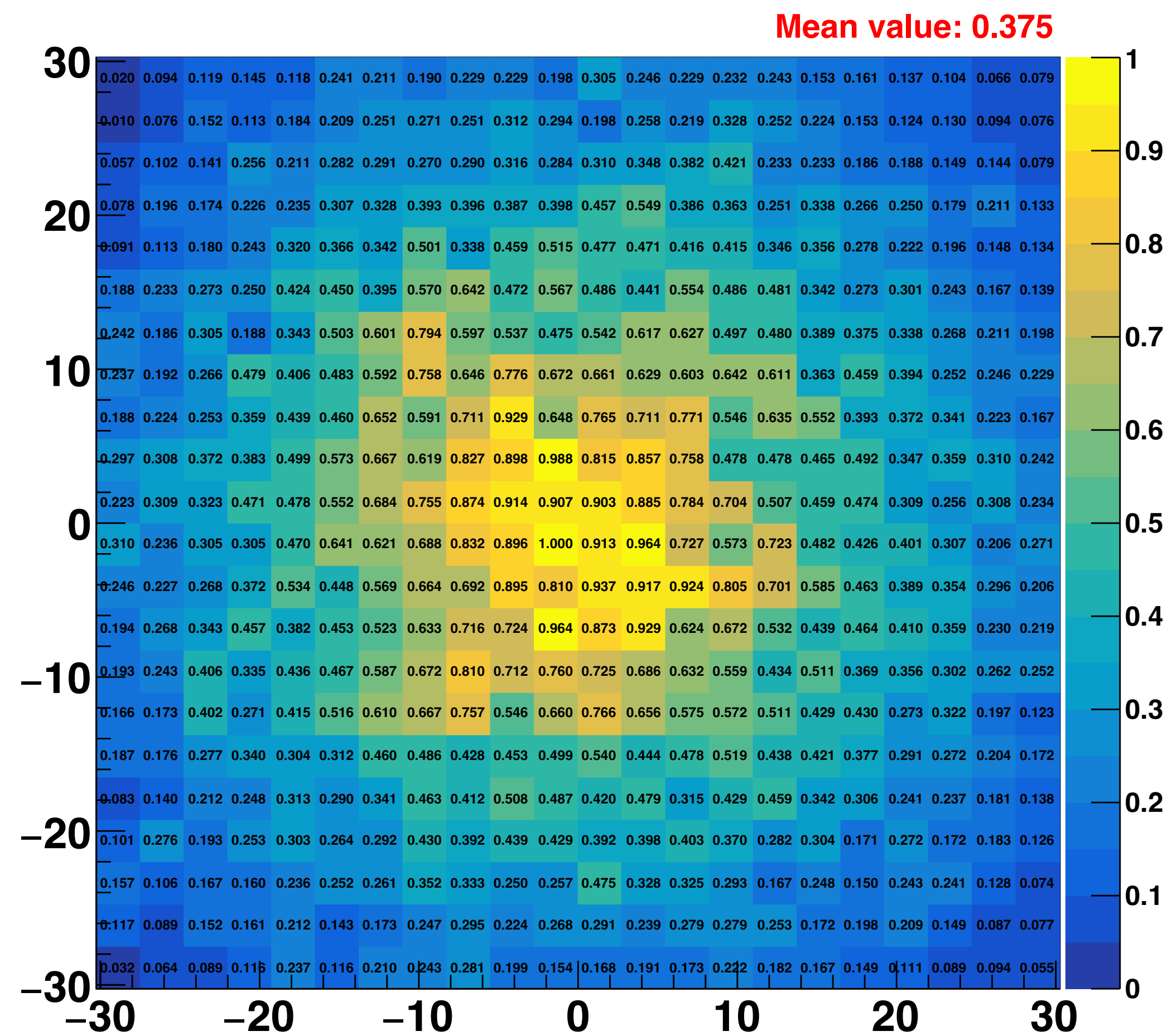

• Geometry 6

PMMA

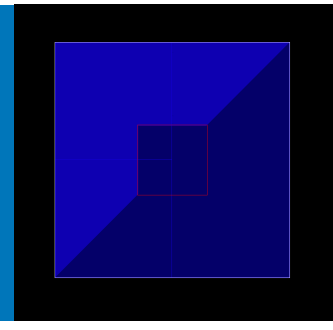

22x22 – Trap – 18 mm

Efficiency - LG - PMMA - 5cm - 22x22 - 18. mm

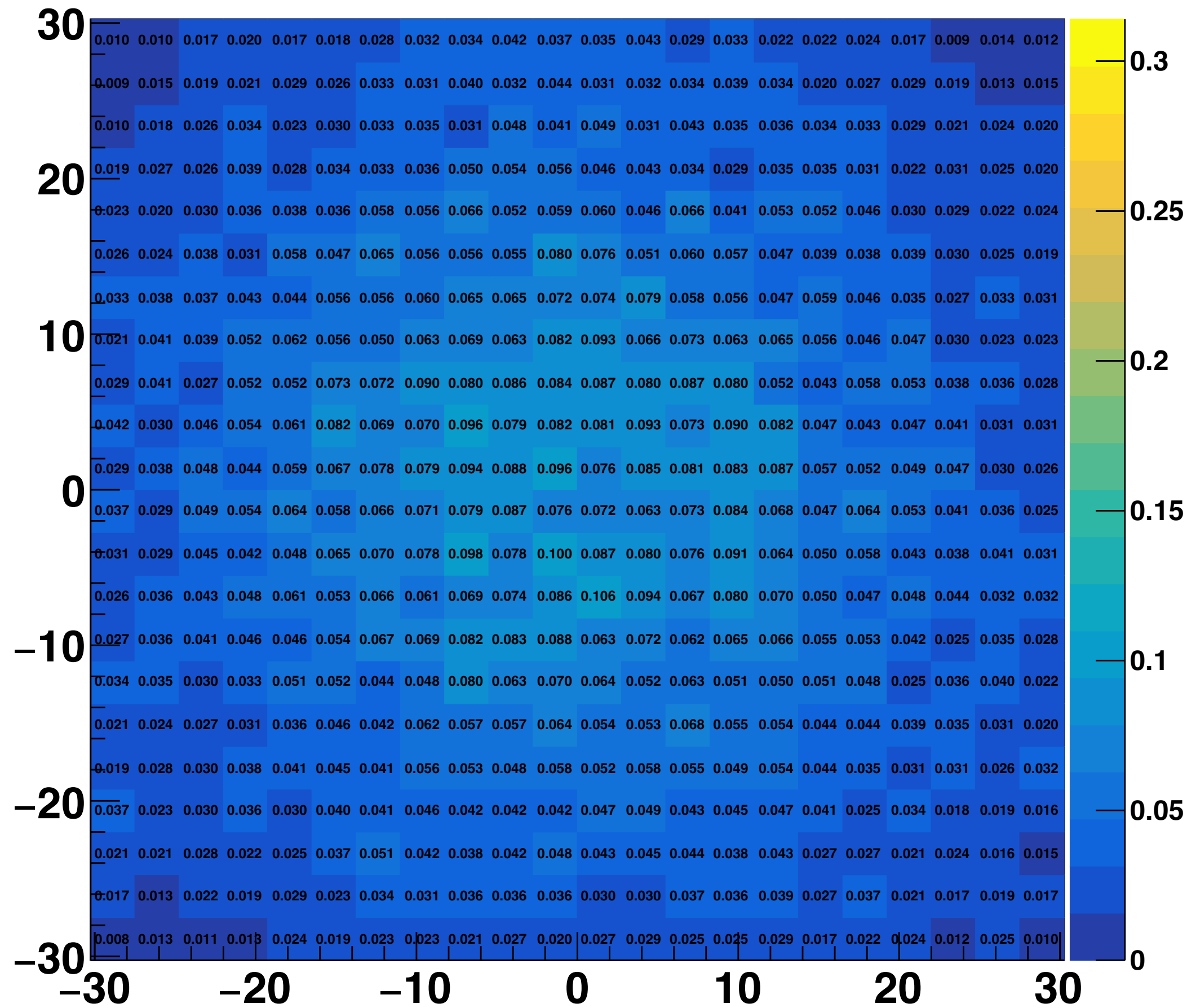

Factor non-uniformity - LG - PMMA - 5cm - 22x22 - 18. mm

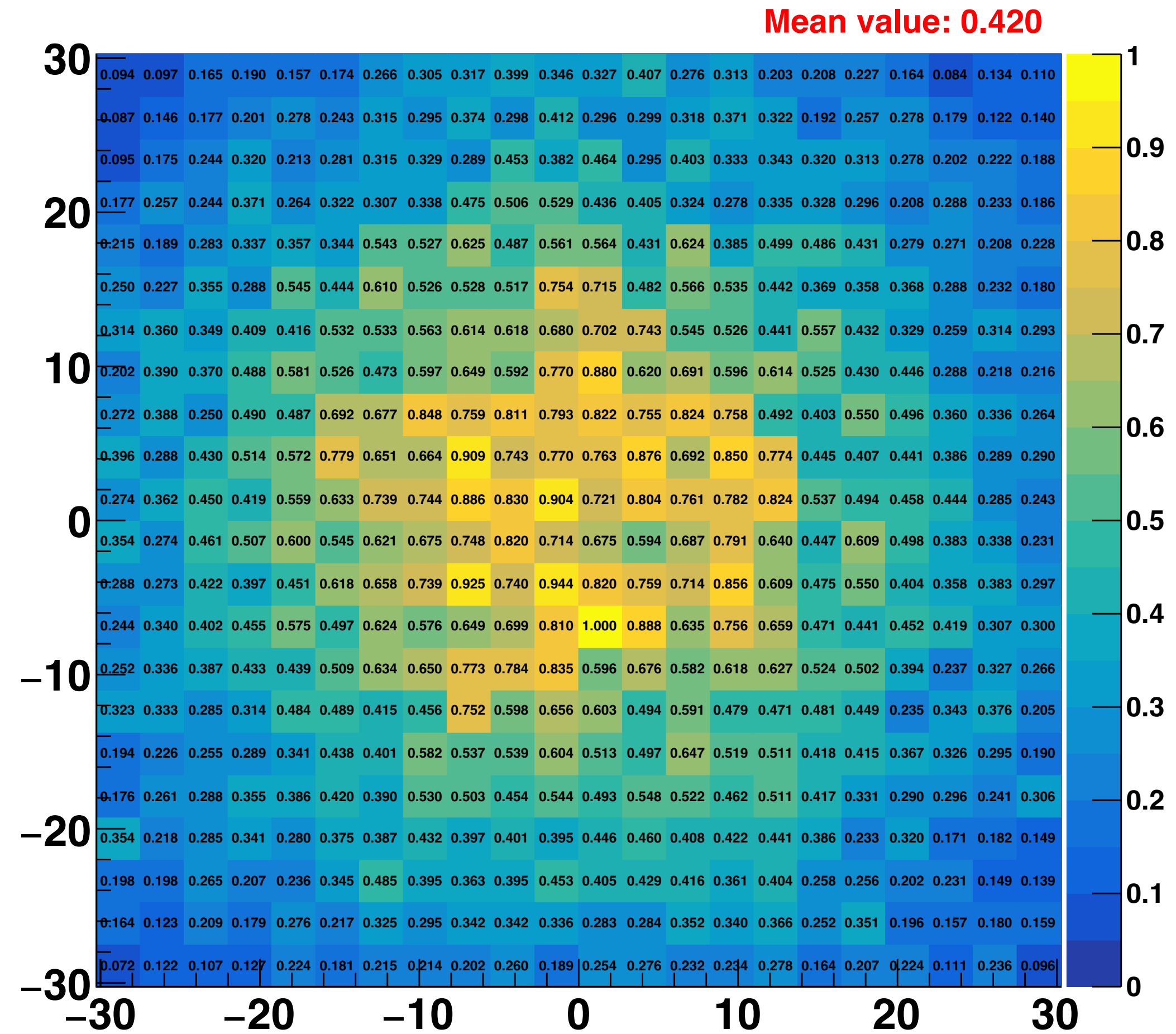

• Geometry 6

PMMA

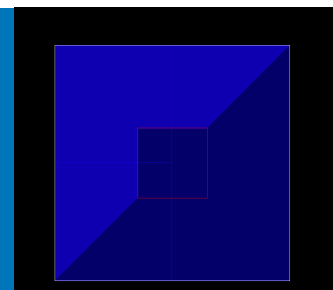

22x22 – Trap – 18 mm

Efficiency - LG - PMMA - 6cm - 22x22 - 18. mm

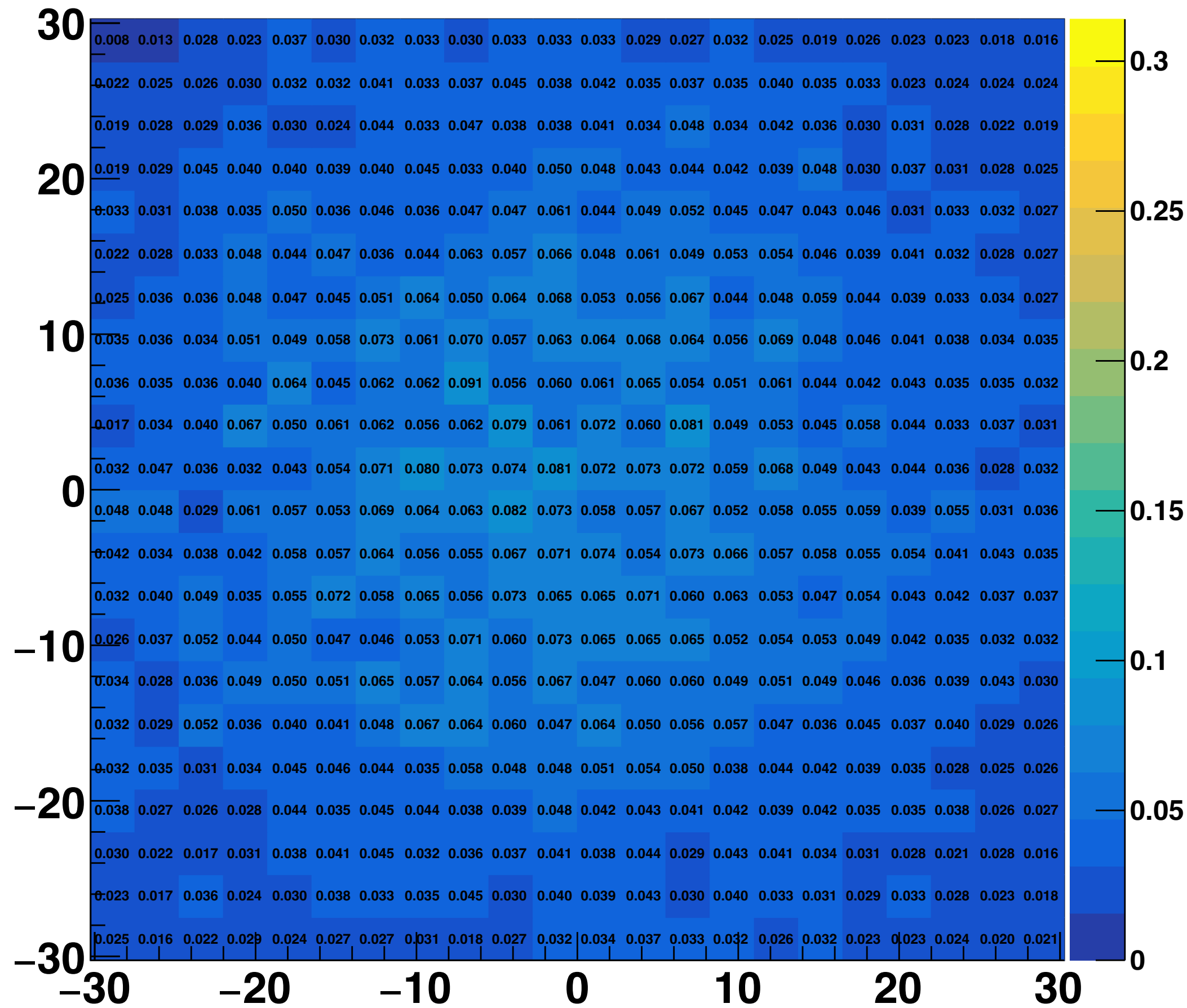

Factor non-uniformity - LG - PMMA - 6cm - 22x22 - 18. mm

Mean value: 0.471

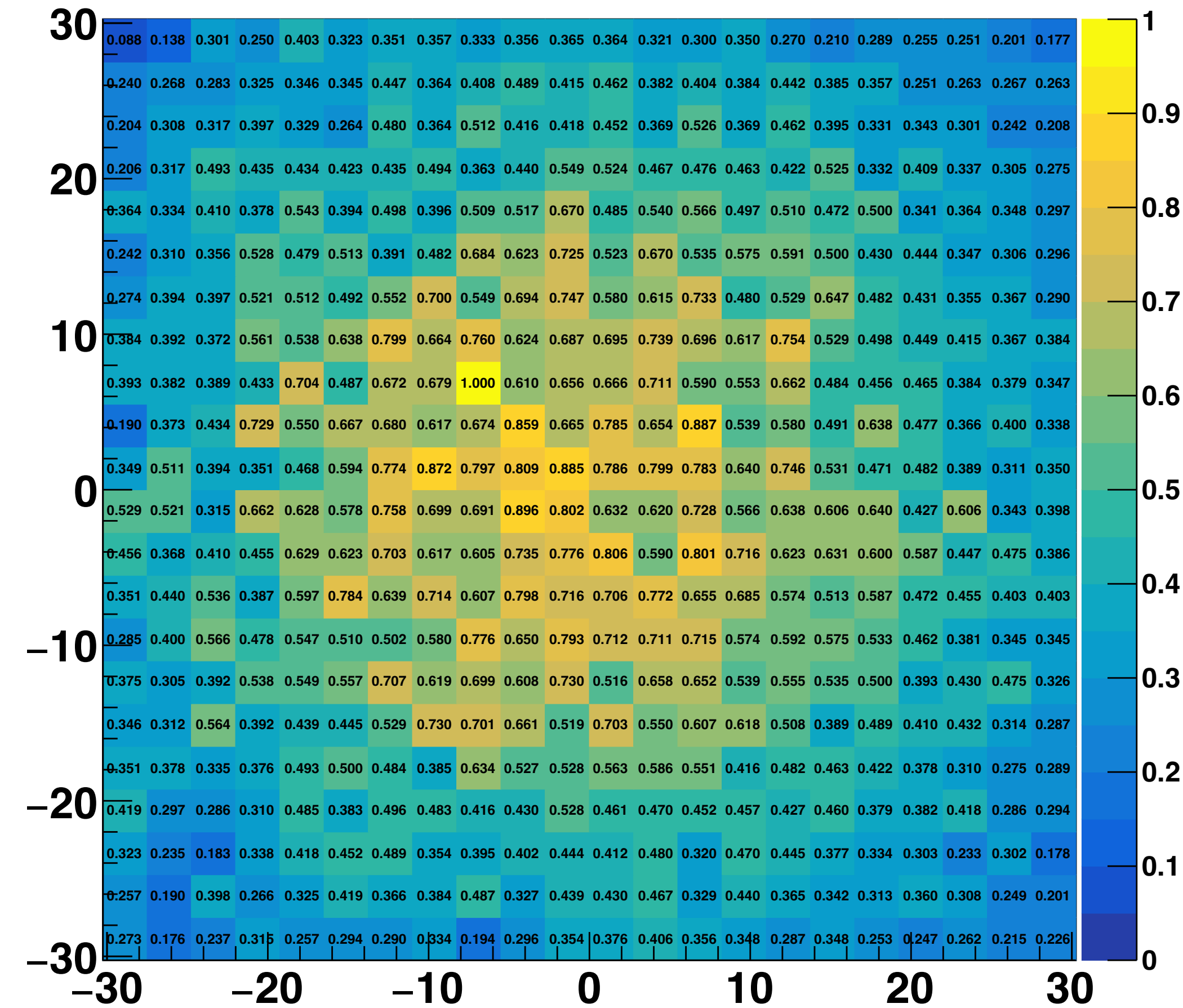

• Geometry 6

AIR

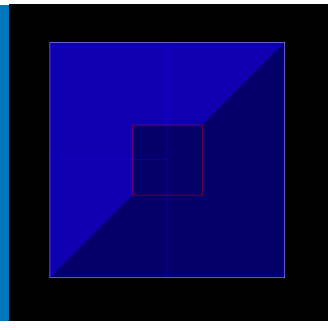

22x22 – Trap – 18 mm

Efficiency - LG - Air - 2cm - 22x22 - 18. mm

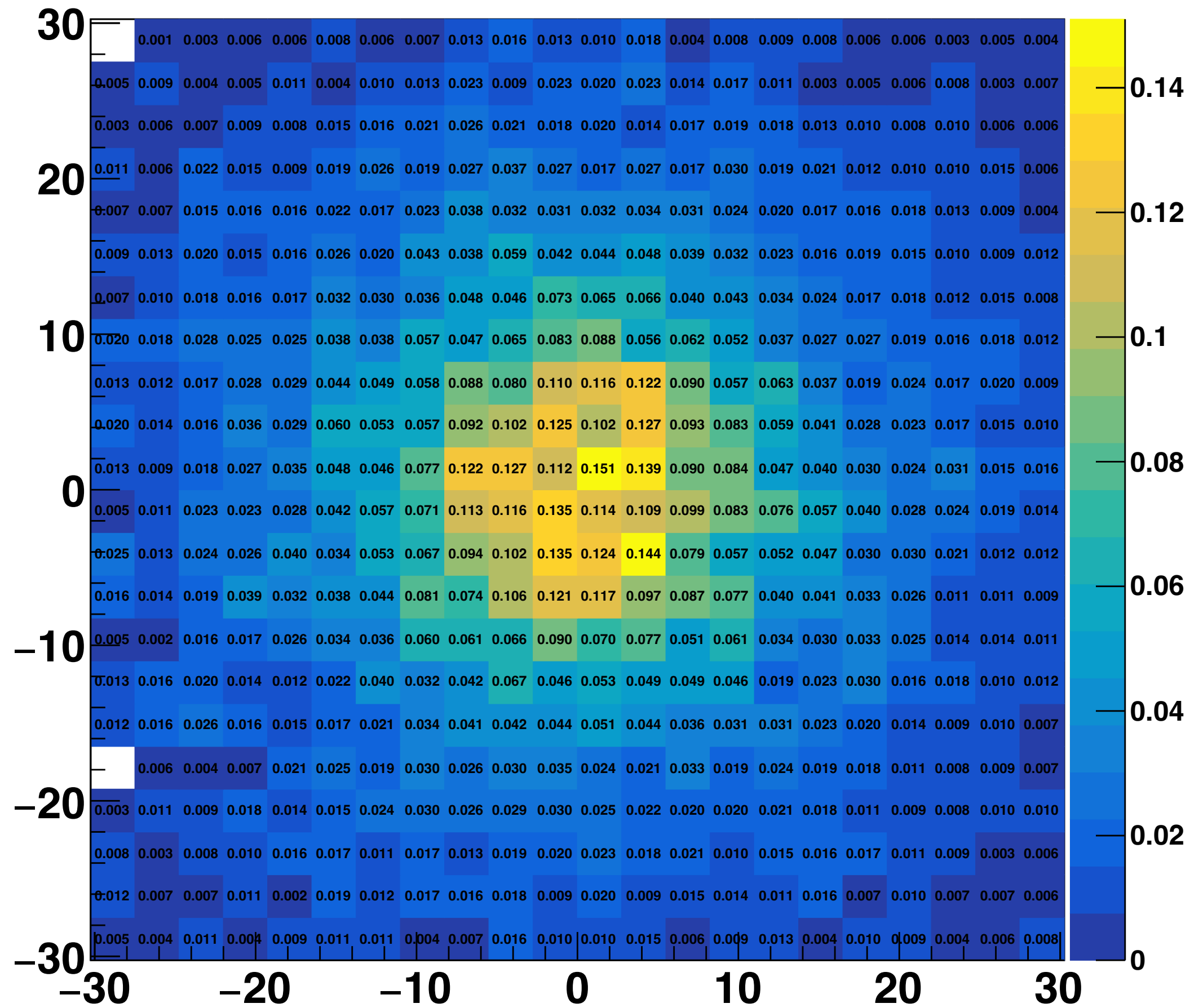

Factor non-uniformity - LG - Air - 2cm - 22x22 - 18. mm

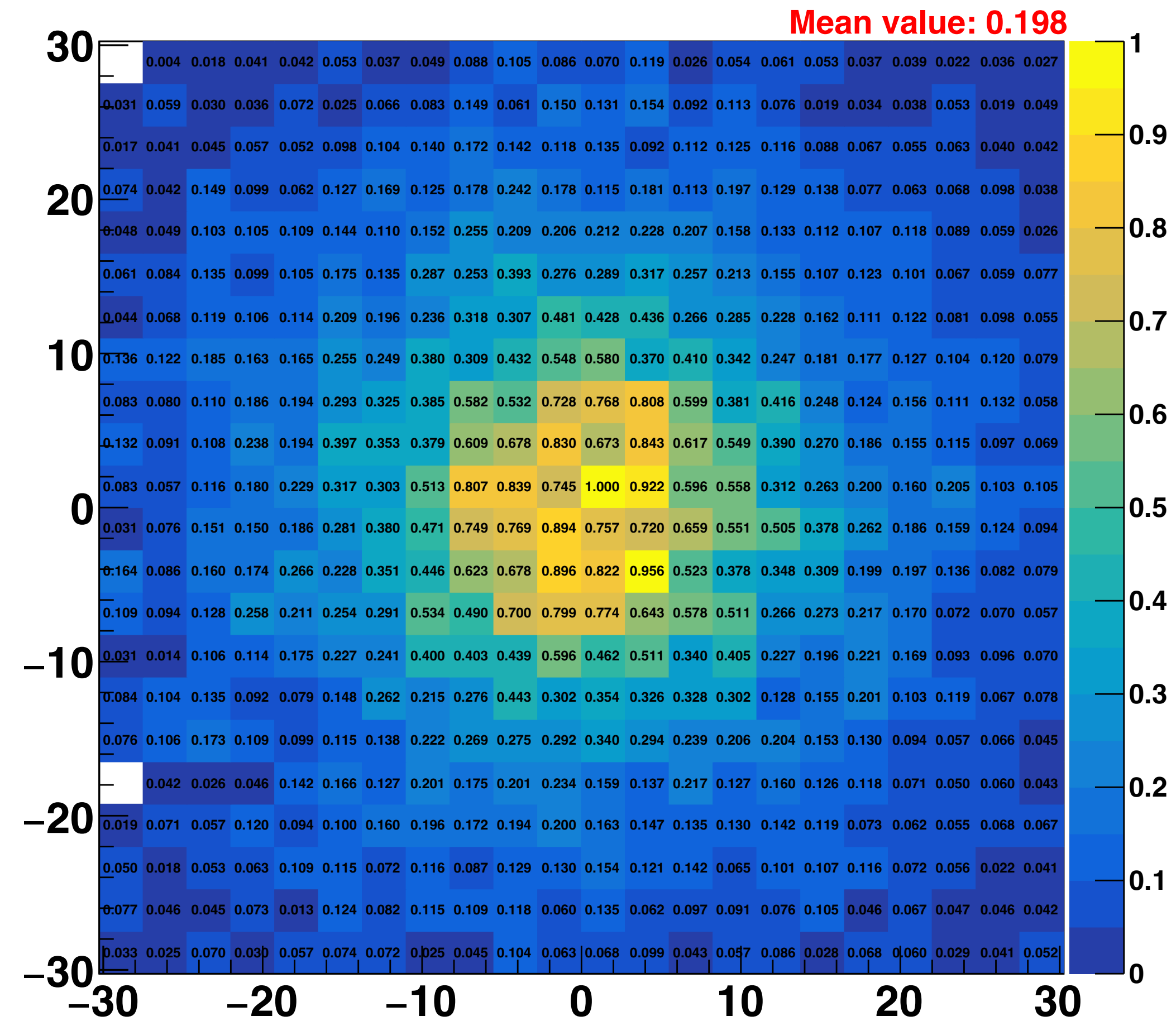

• Geometry 6

AIR

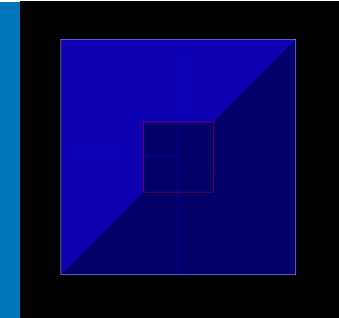

22x22 – Trap – 18 mm

Efficiency - LG - Air - 3cm - 22x22 - 18. mm

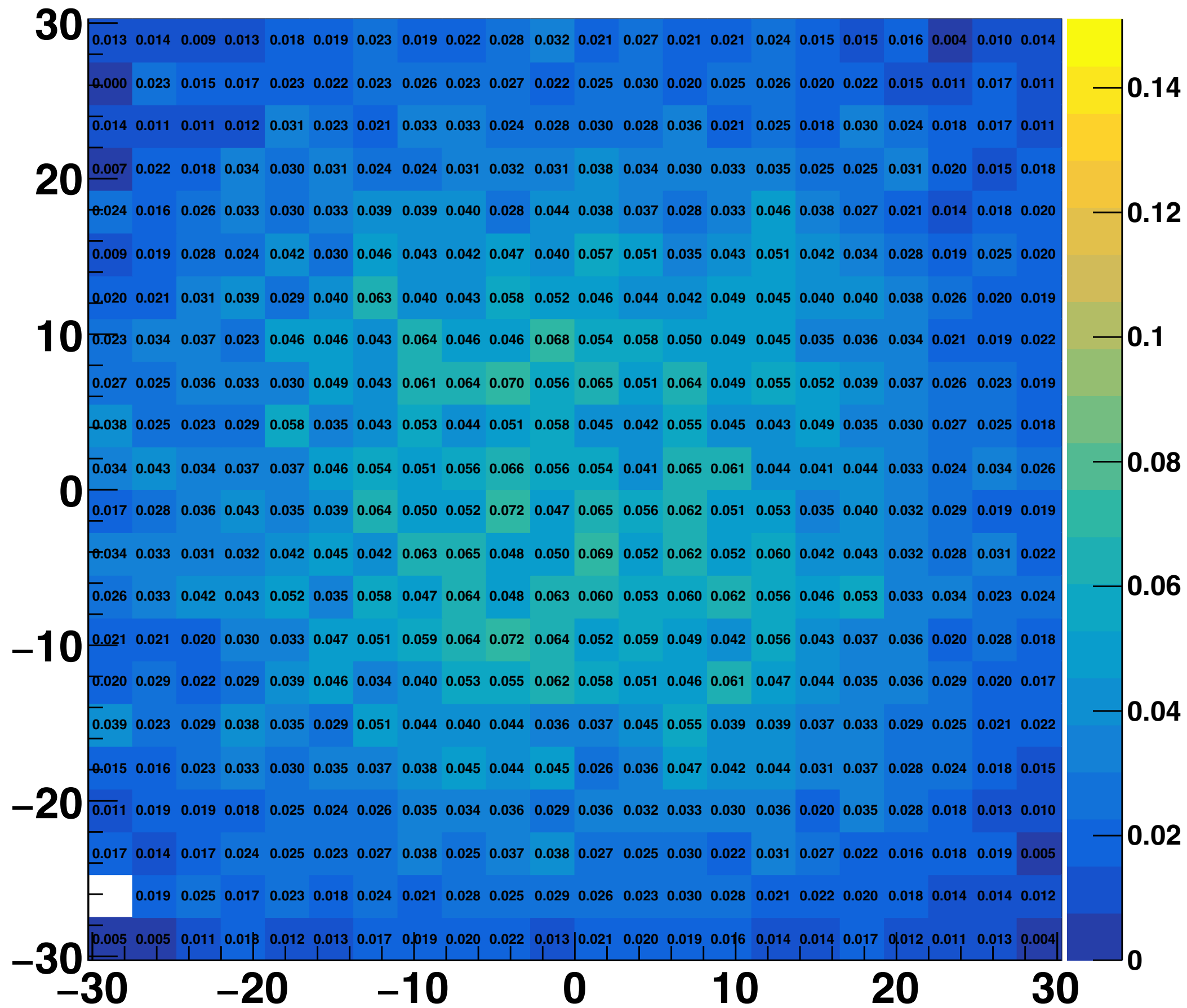

Factor non-uniformity - LG - Air - 3cm - 22x22 - 18. mm

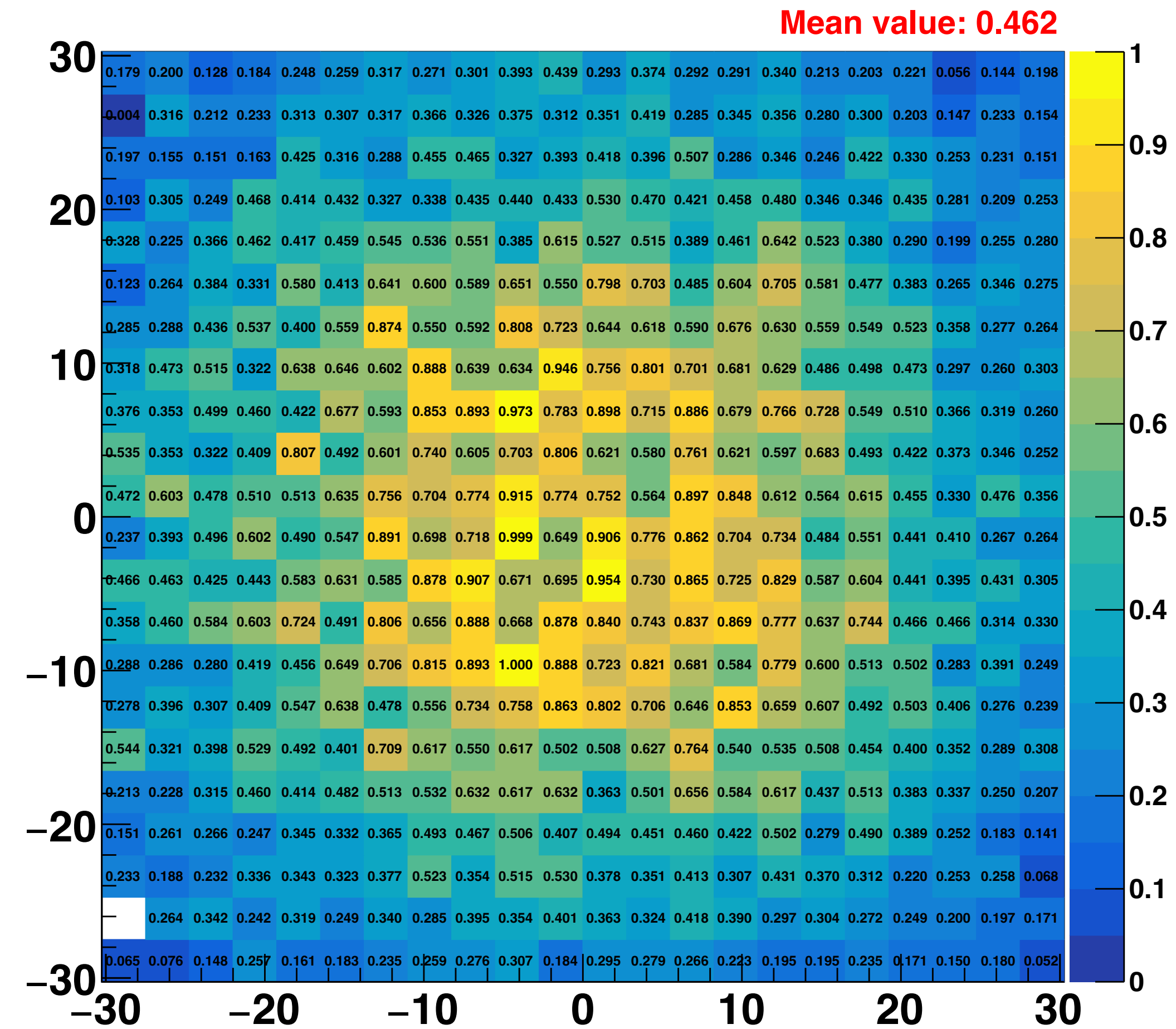

• Geometry 6

AIR

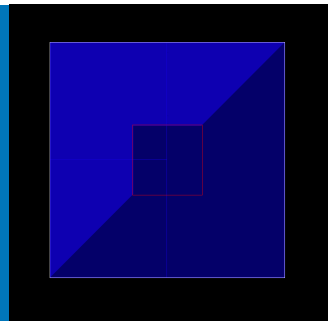

22x22 – Trap – 18 mm

Efficiency - LG - Air - 4cm - 22x22 - 18. mm

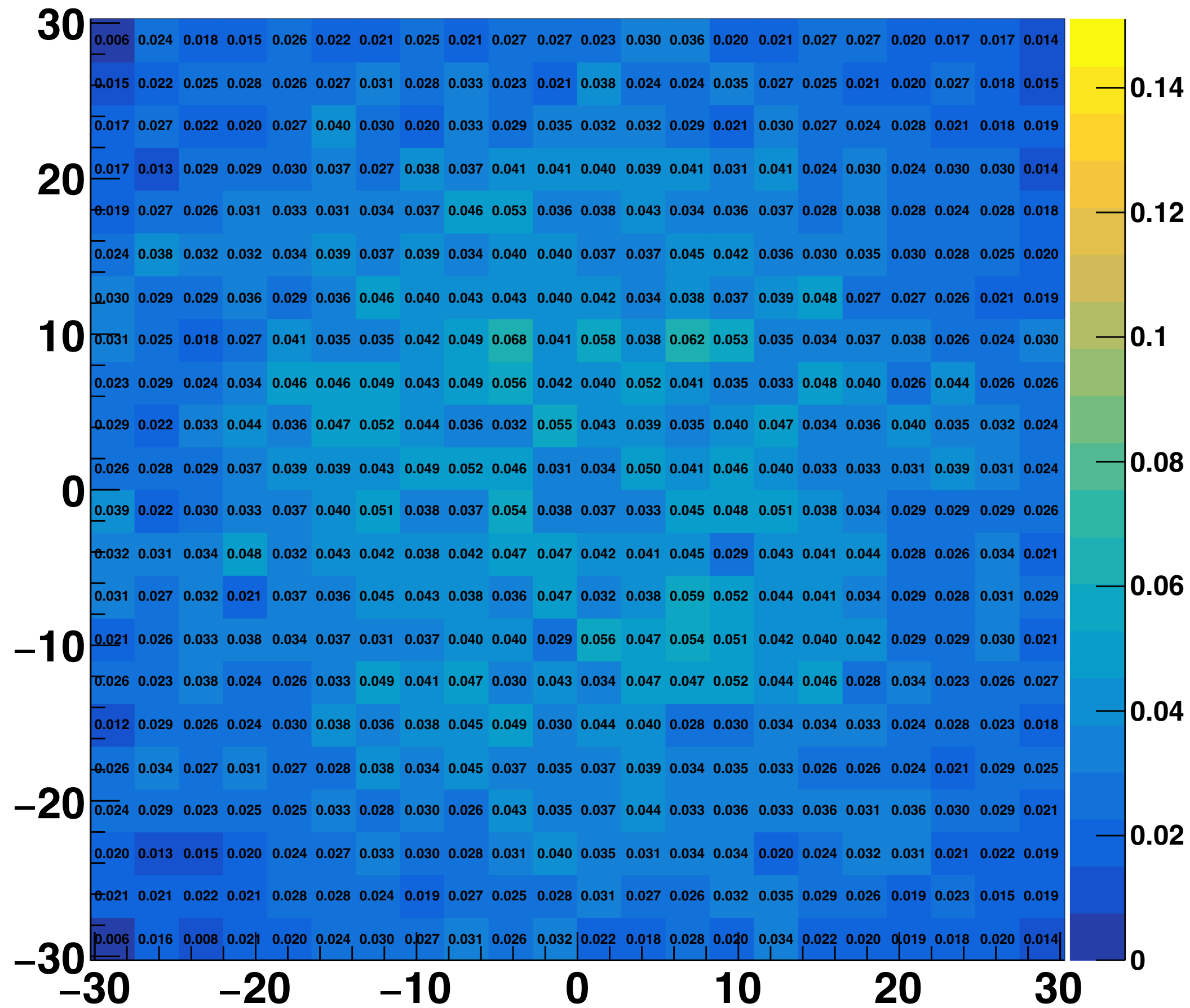

Factor non-uniformity - LG - Air - 4cm - 22x22 - 18. mm

Mean value: 0.477

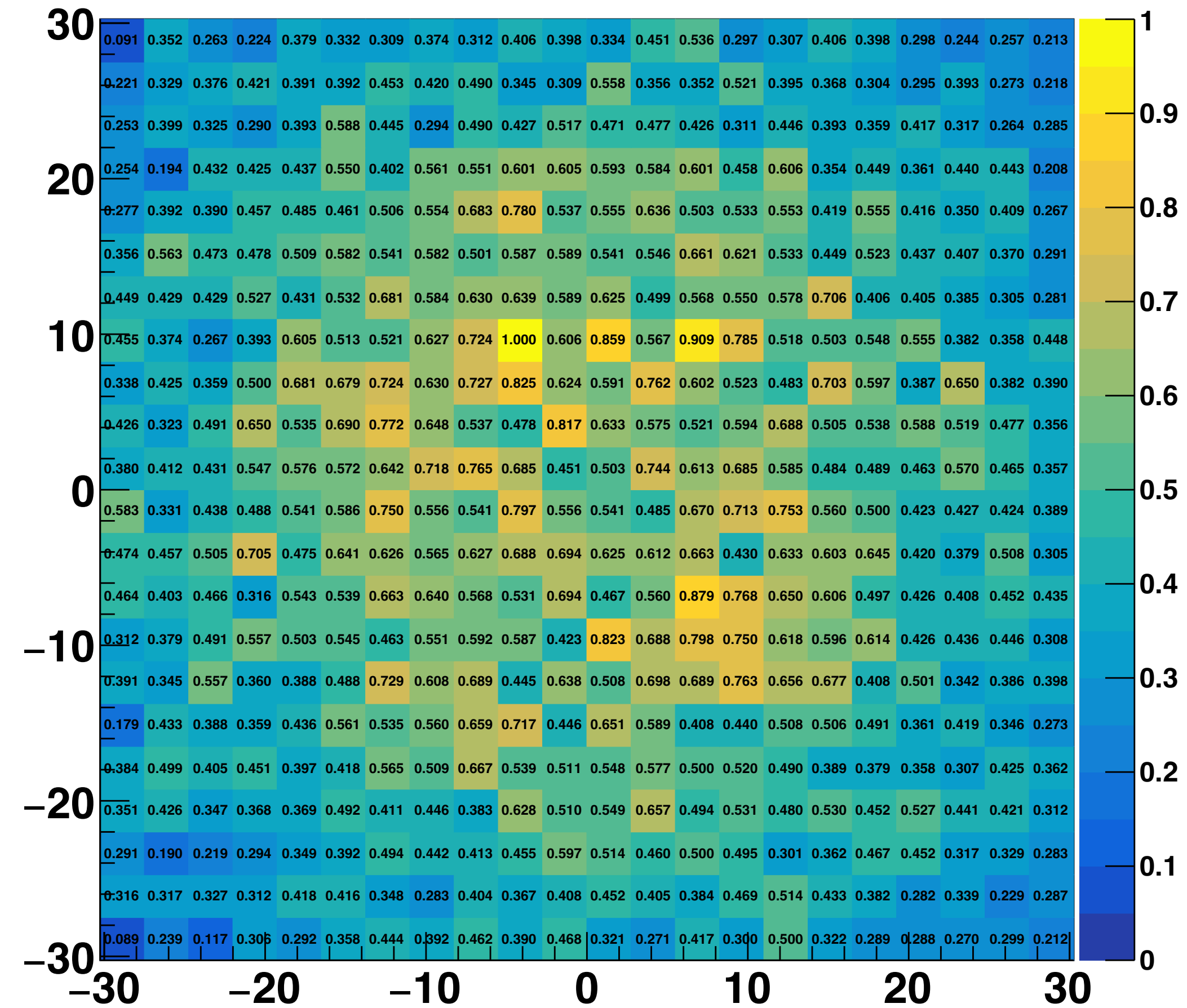

• Geometry 6

AIR

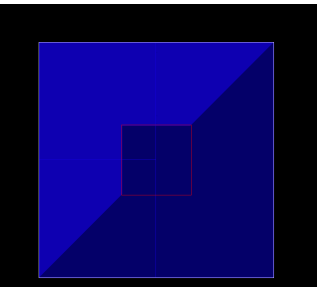

22x22 – Trap – 18 mm

Efficiency - LG - Air - 5cm - 22x22 - 18. mm

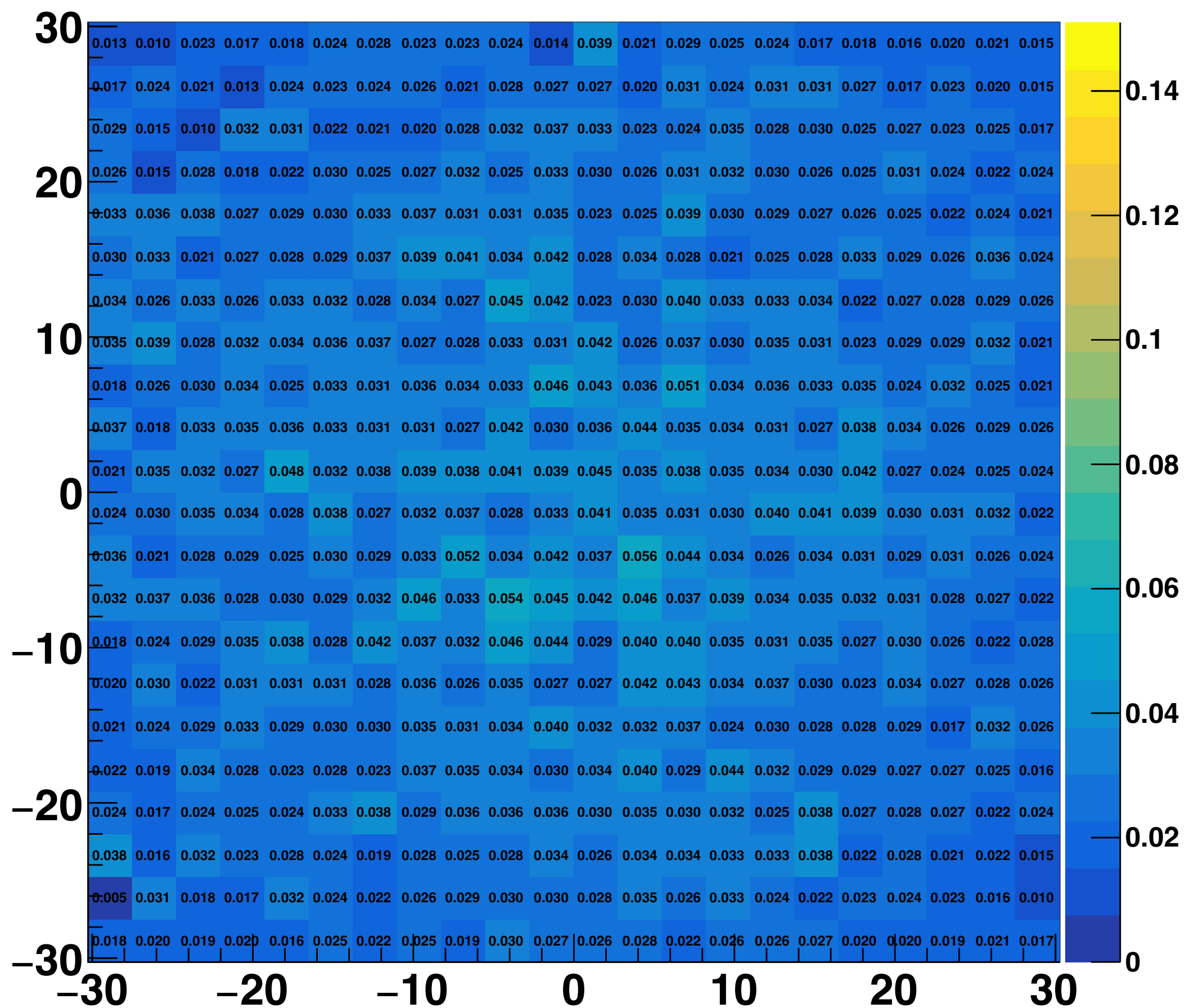

Factor non-uniformity - LG - Air - 5cm - 22x22 - 18. mm

Mean value: 0.527

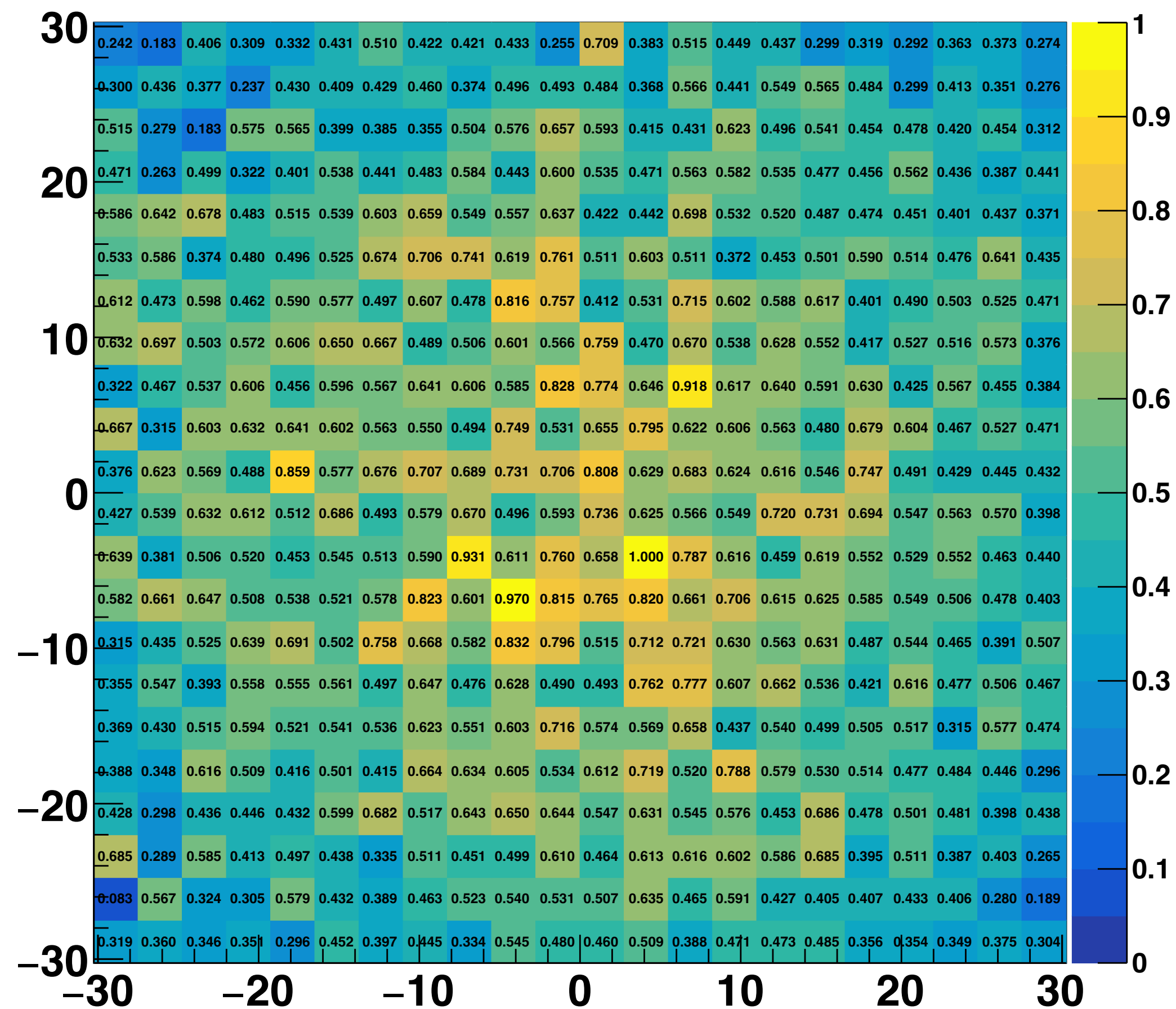

• Geometry 6

AIR

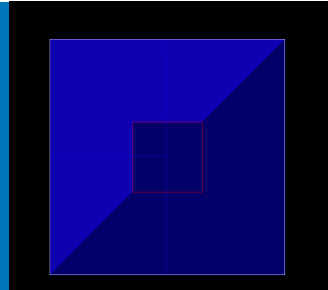

22x22 – Trap – 18 mm

Efficiency - LG - Air - 6cm - 22x22 - 18. mm

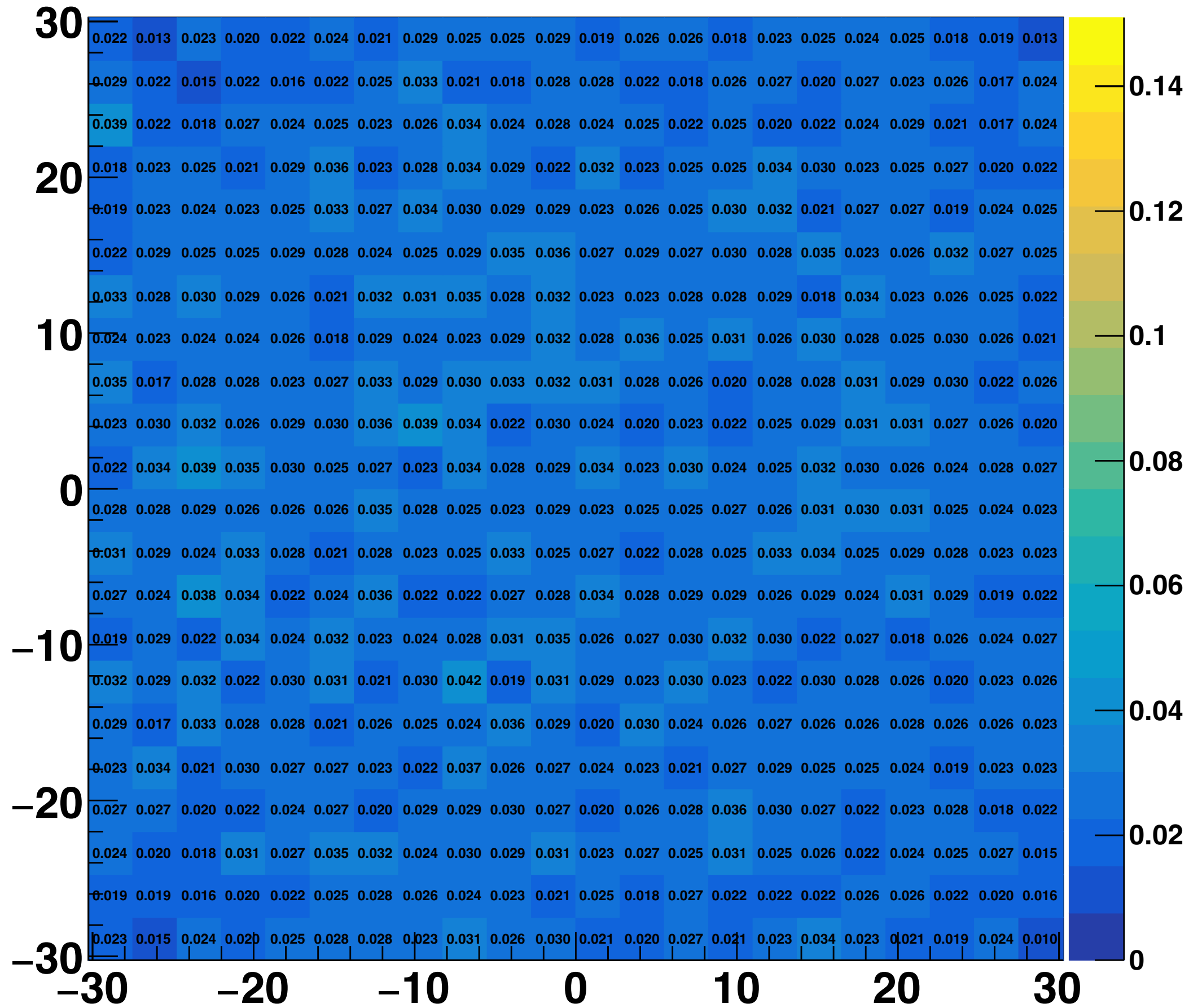

Factor non-uniformity - LG - Air - 6cm - 22x22 - 18. mm

Mean value: 0.615

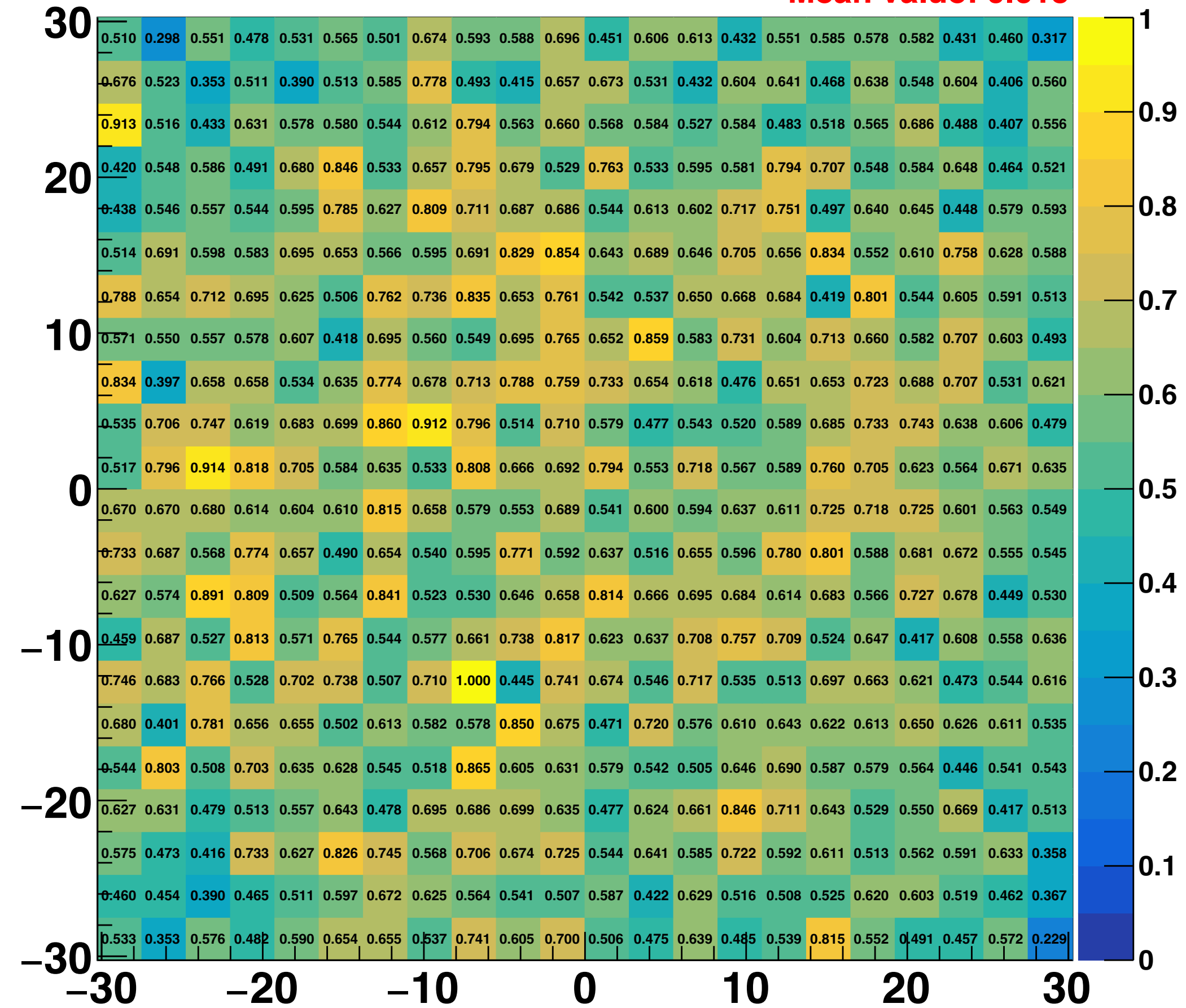

back up slides

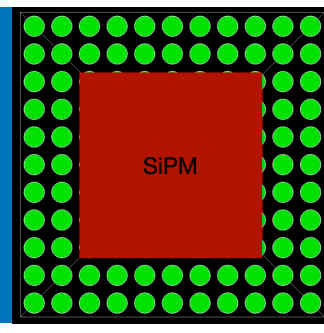

Efficiency - LG - PMMA - 2cm - base 18. mm

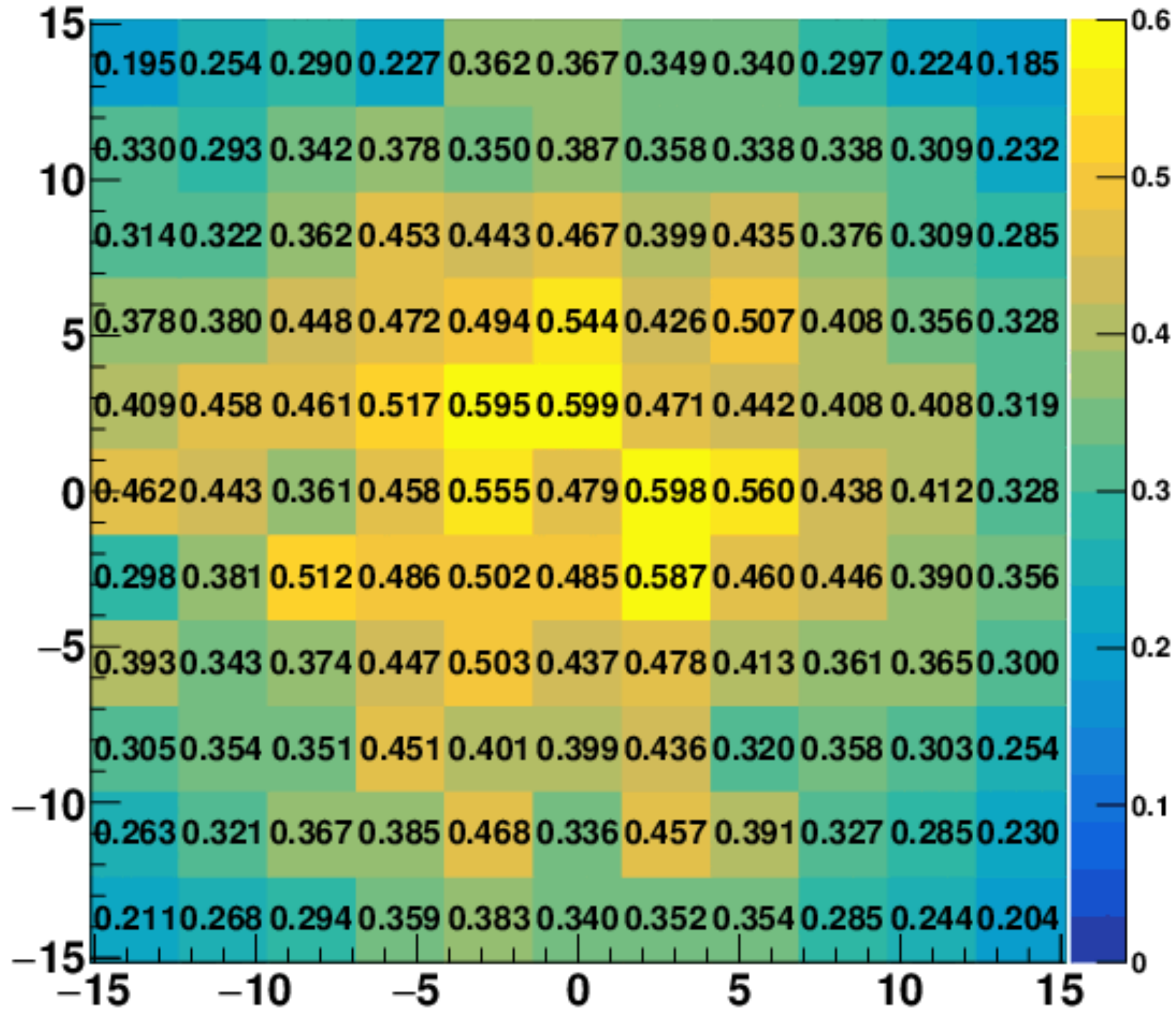

Factor non-uniformity - LG - PMMA - 2cm - base 18. mm

Mean value: 0.638

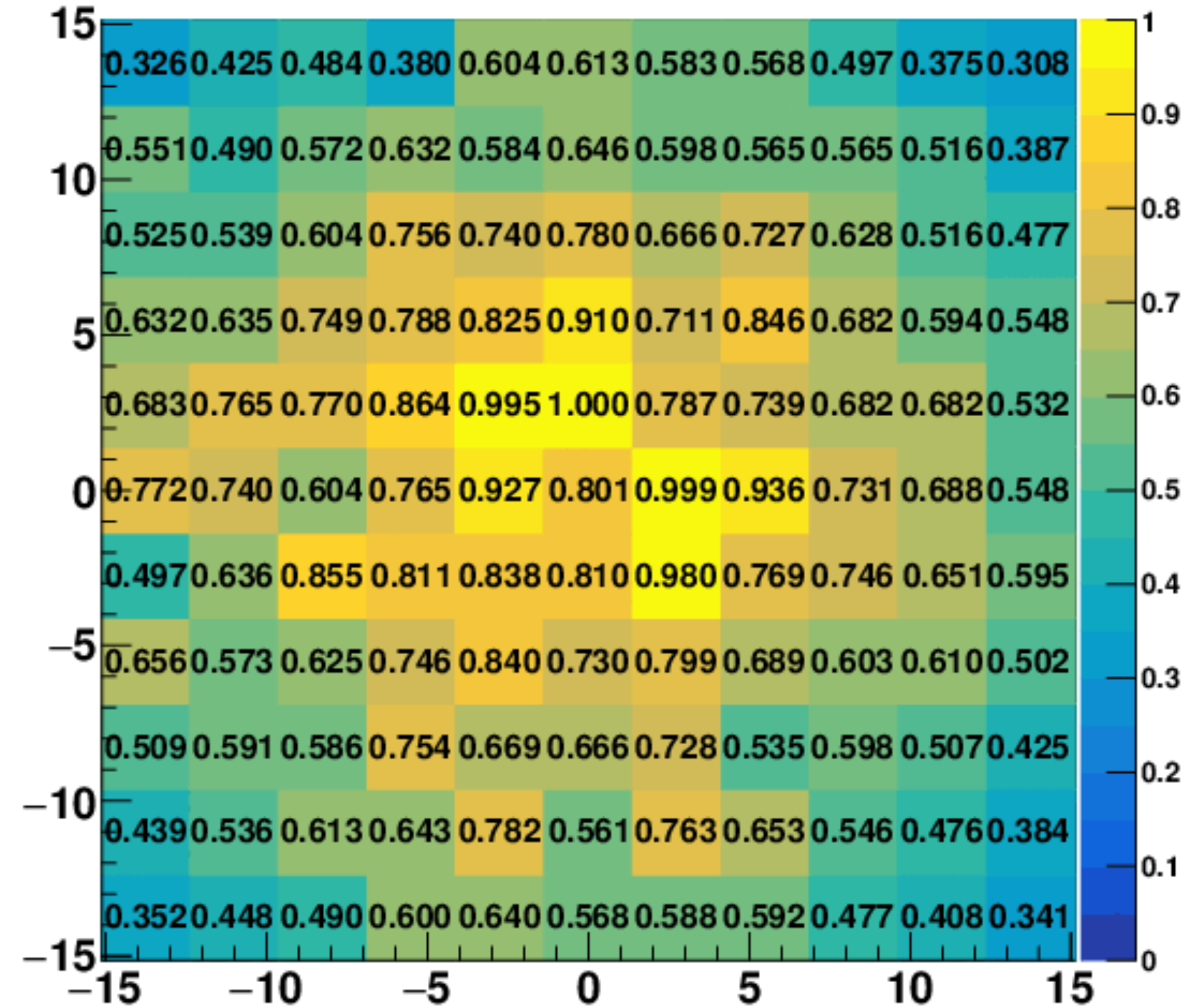

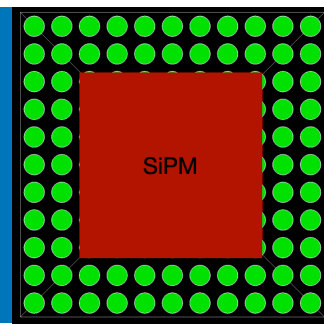

Efficiency - LG - Air - 2cm - base 18. mm

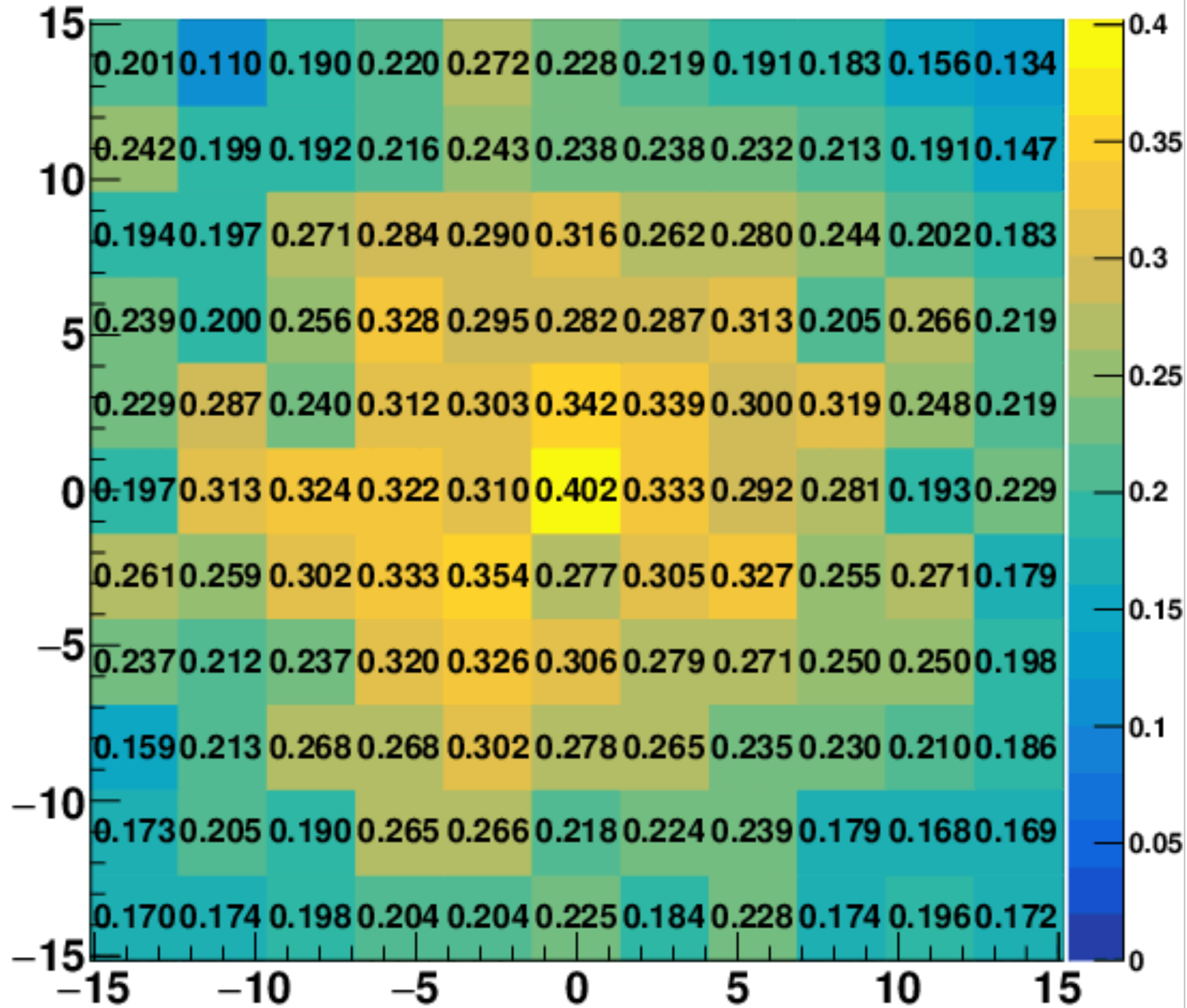

Factor non-uniformity - LG - AIR - 2cm - base 18. mm

Mean value: 0.606

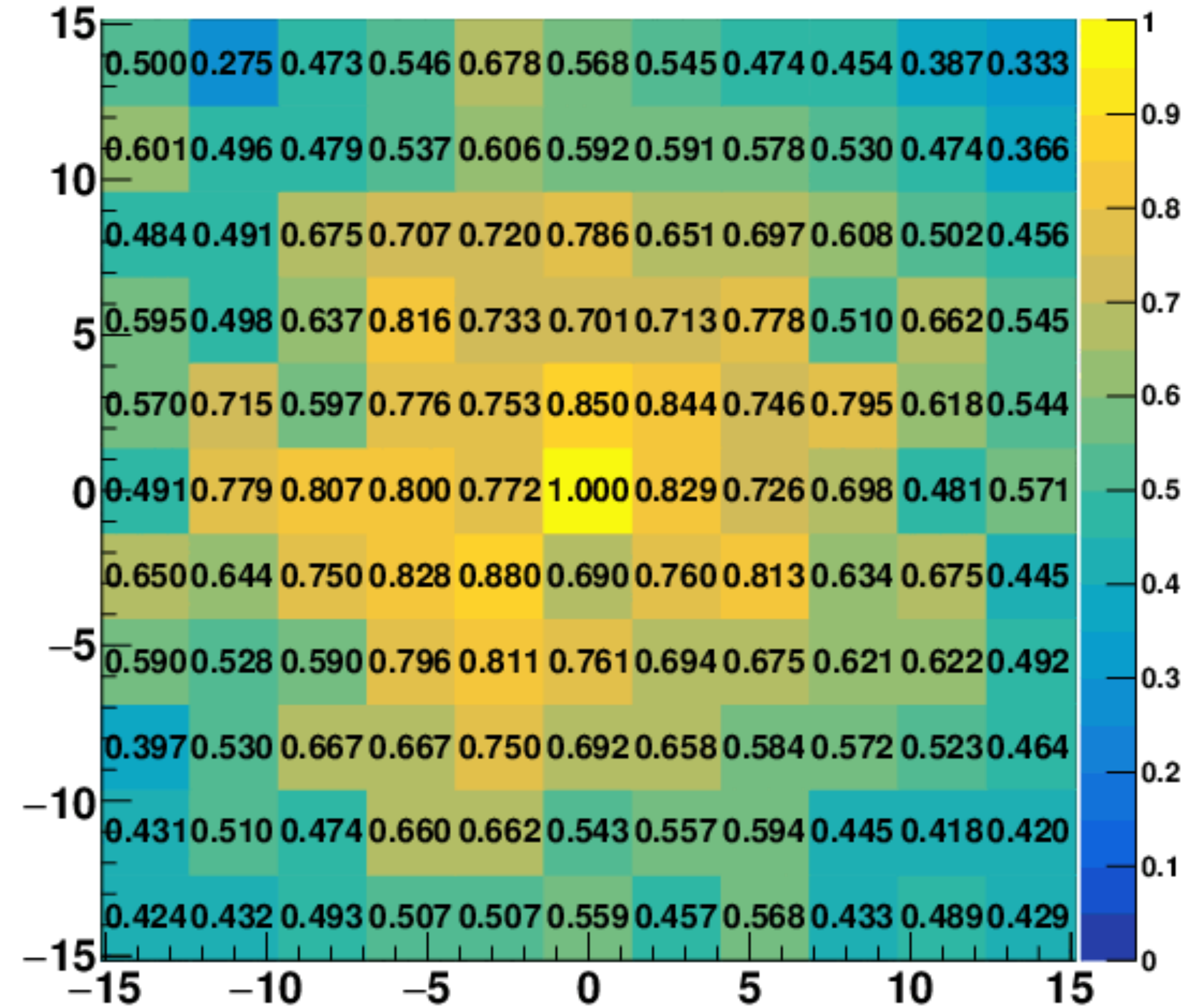

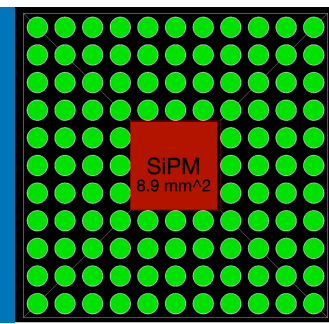

Efficiency - LG - PMMA - 2cm - base 8.9 mm

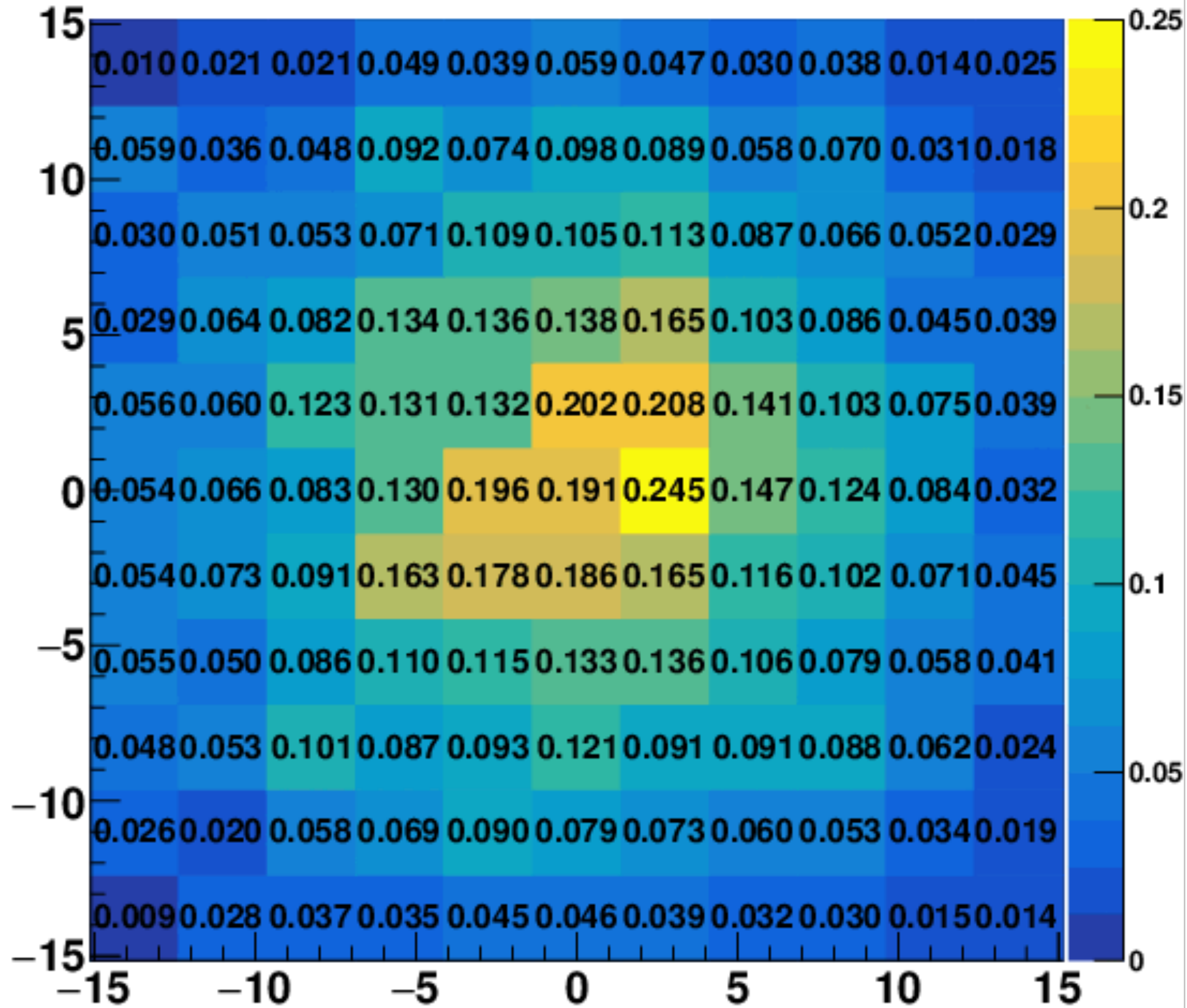

Factor non-uniformity - LG - PMMA - 2cm - base 8.9 mm

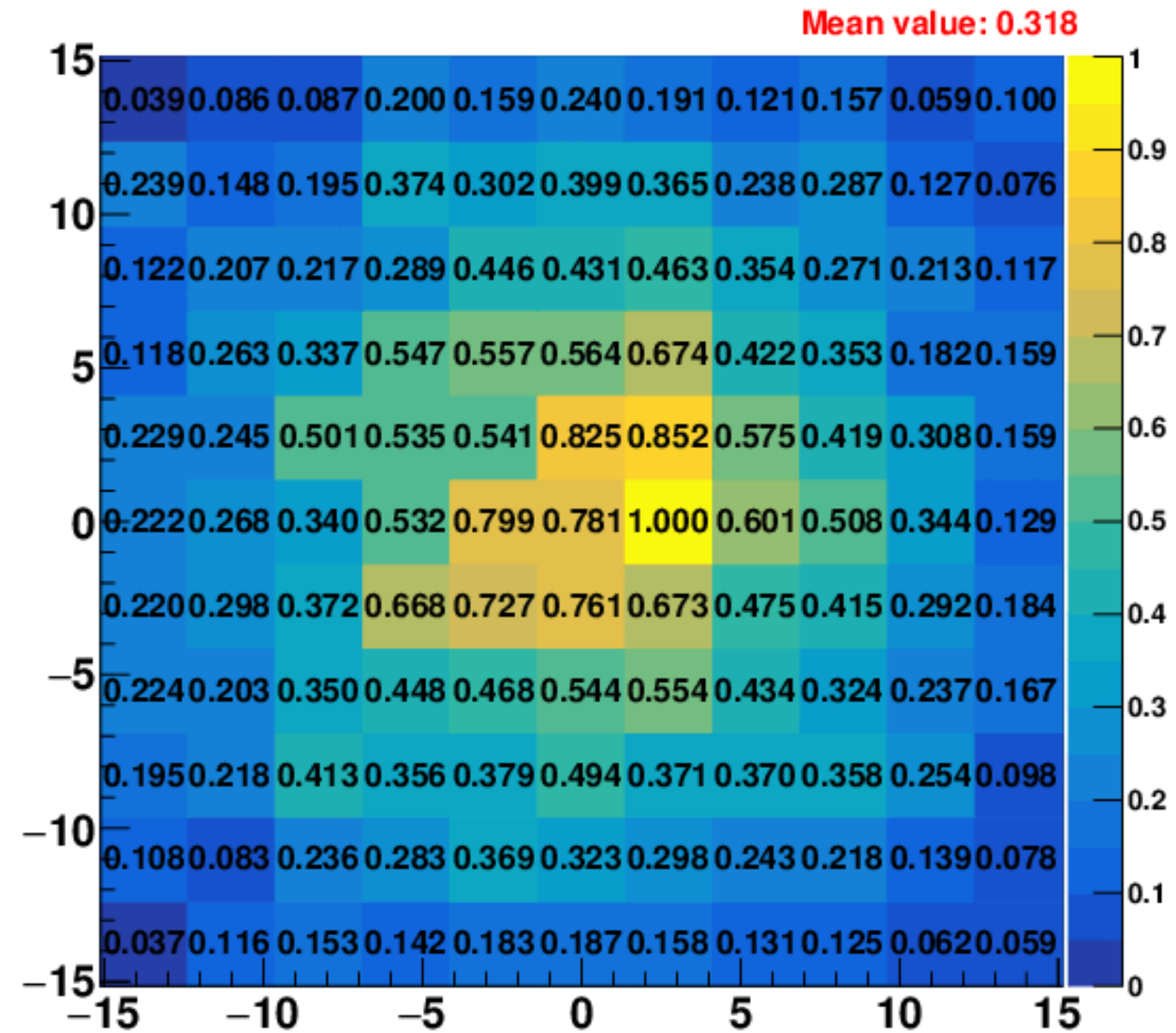

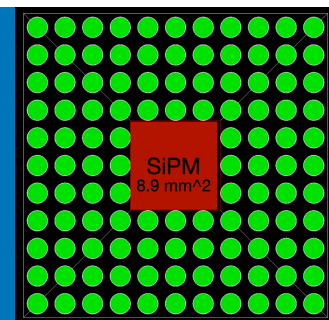

Efficiency - LG - Air - 2cm - base 8.9 mm

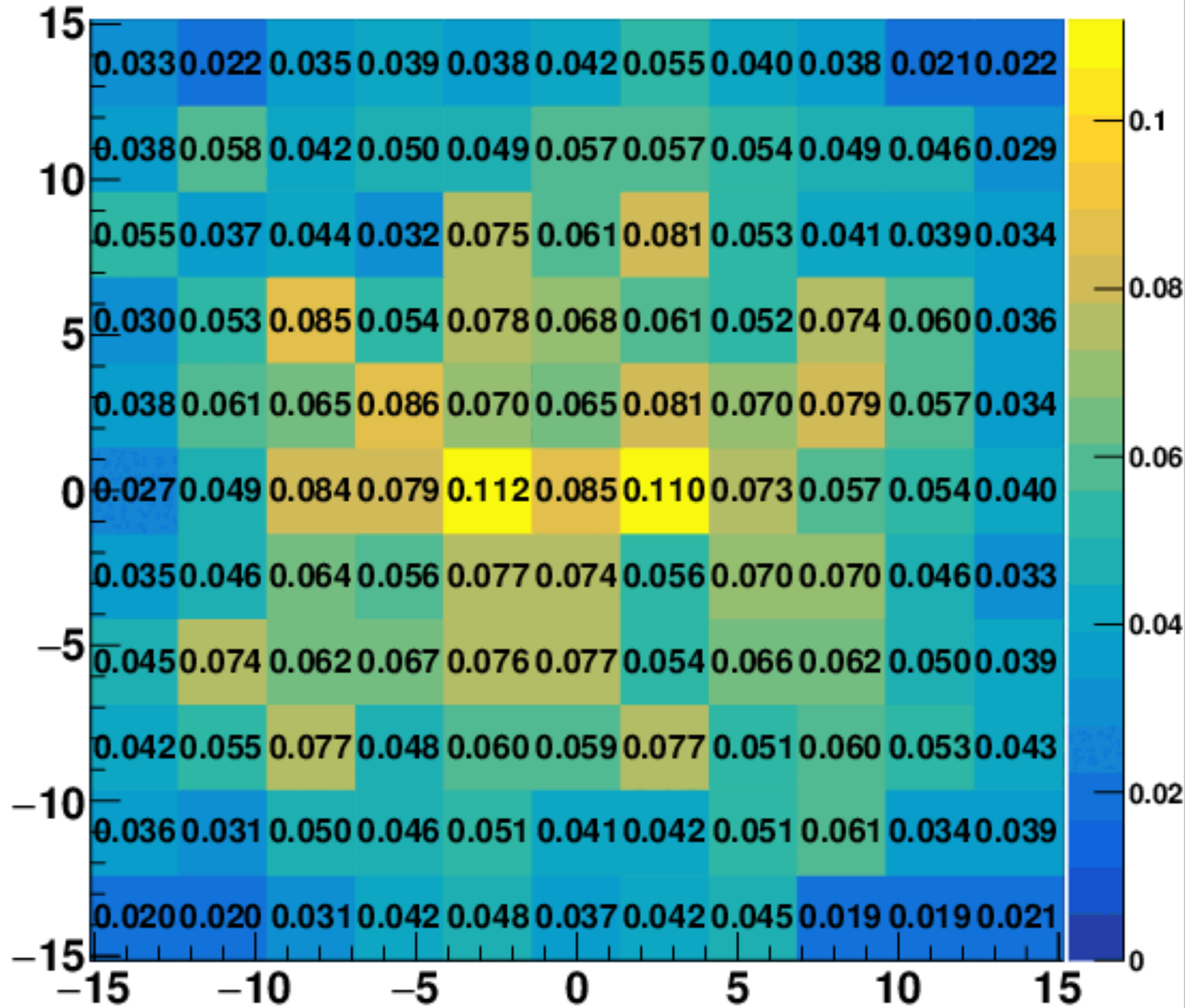

Factor non-uniformity - LG - AIR - 2cm - base 8.9 mm

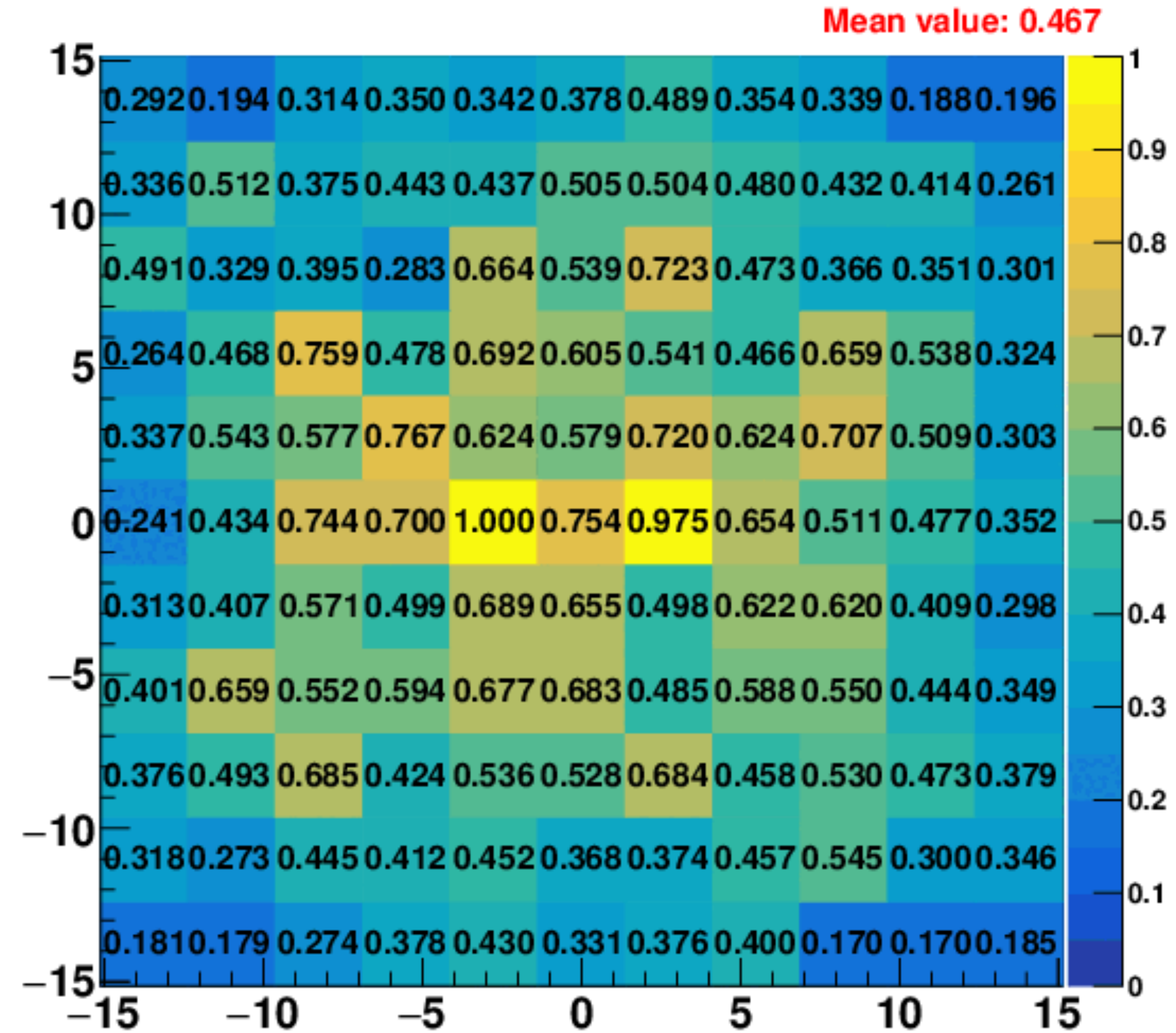

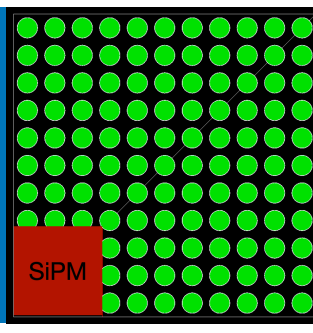

Efficiency - LG - PMMA - 2cm - base 8.9 mm

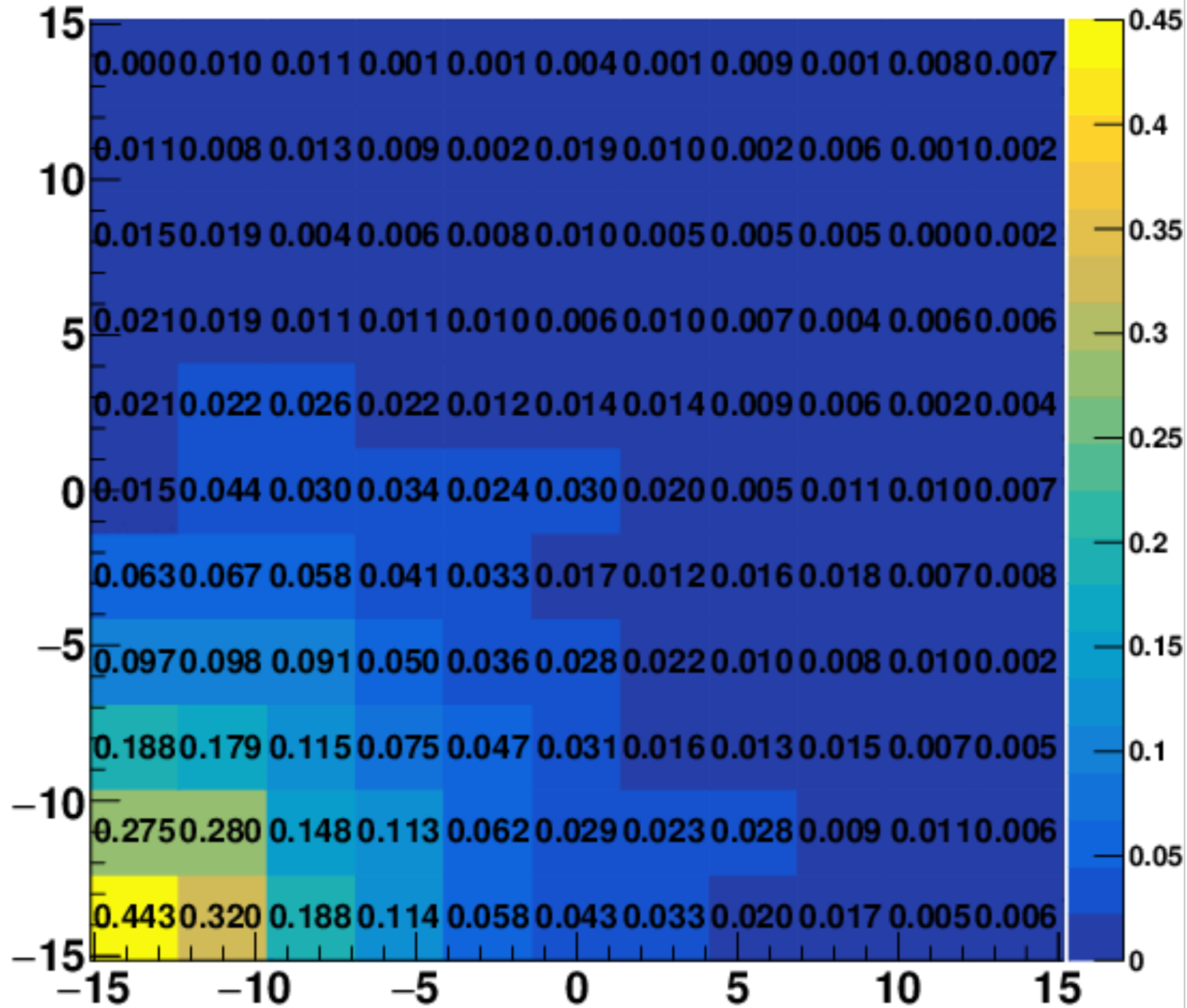

Factor non-uniformity - LG - PMMA - 2cm - base 8.9 mm

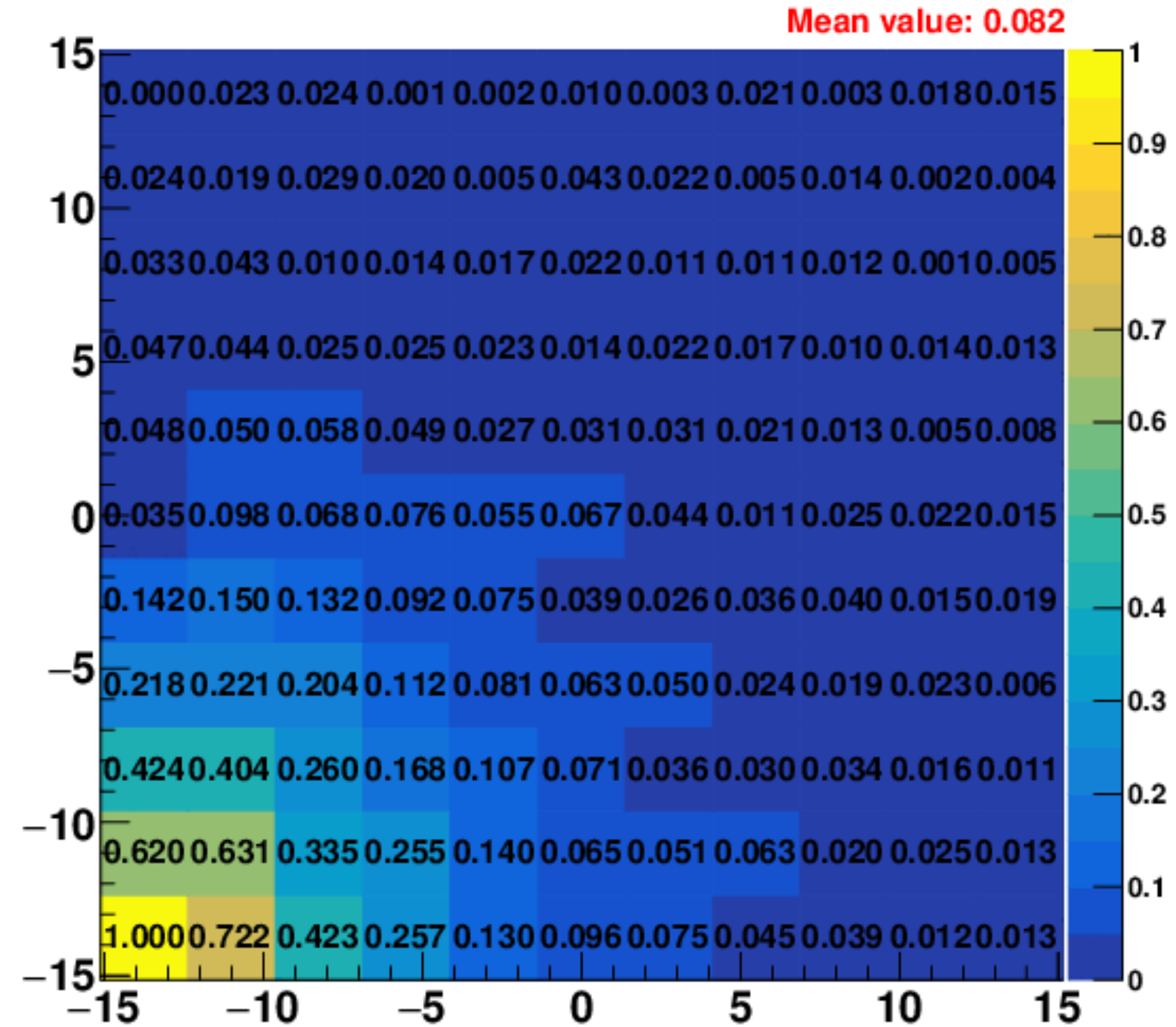

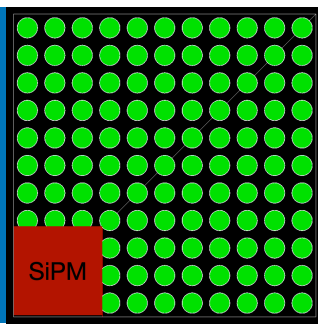

Efficiency - LG - Air - 2cm - base 8.9 mm

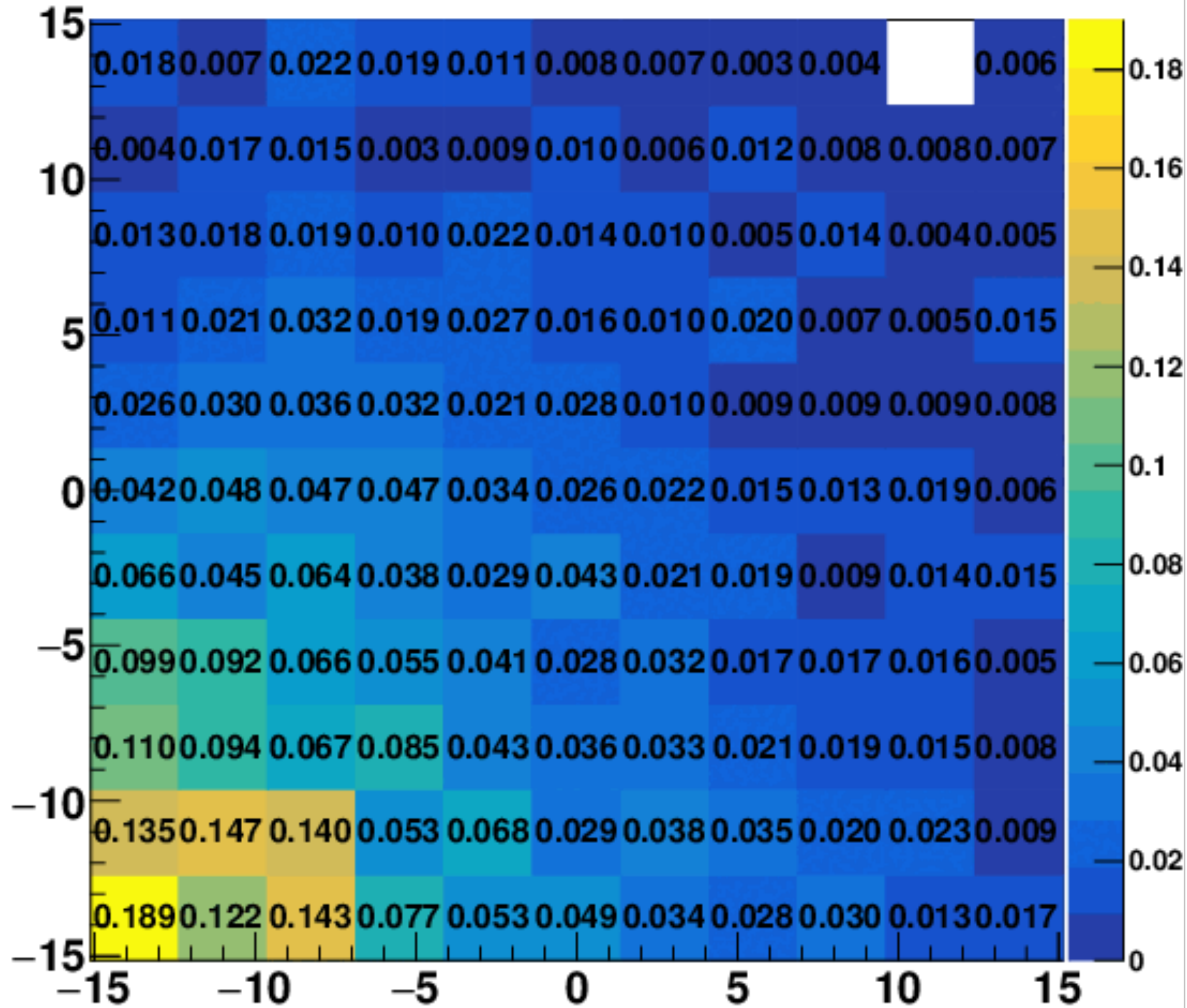

Factor non-uniformity - LG - AIR - 2cm - base 8.9 mm

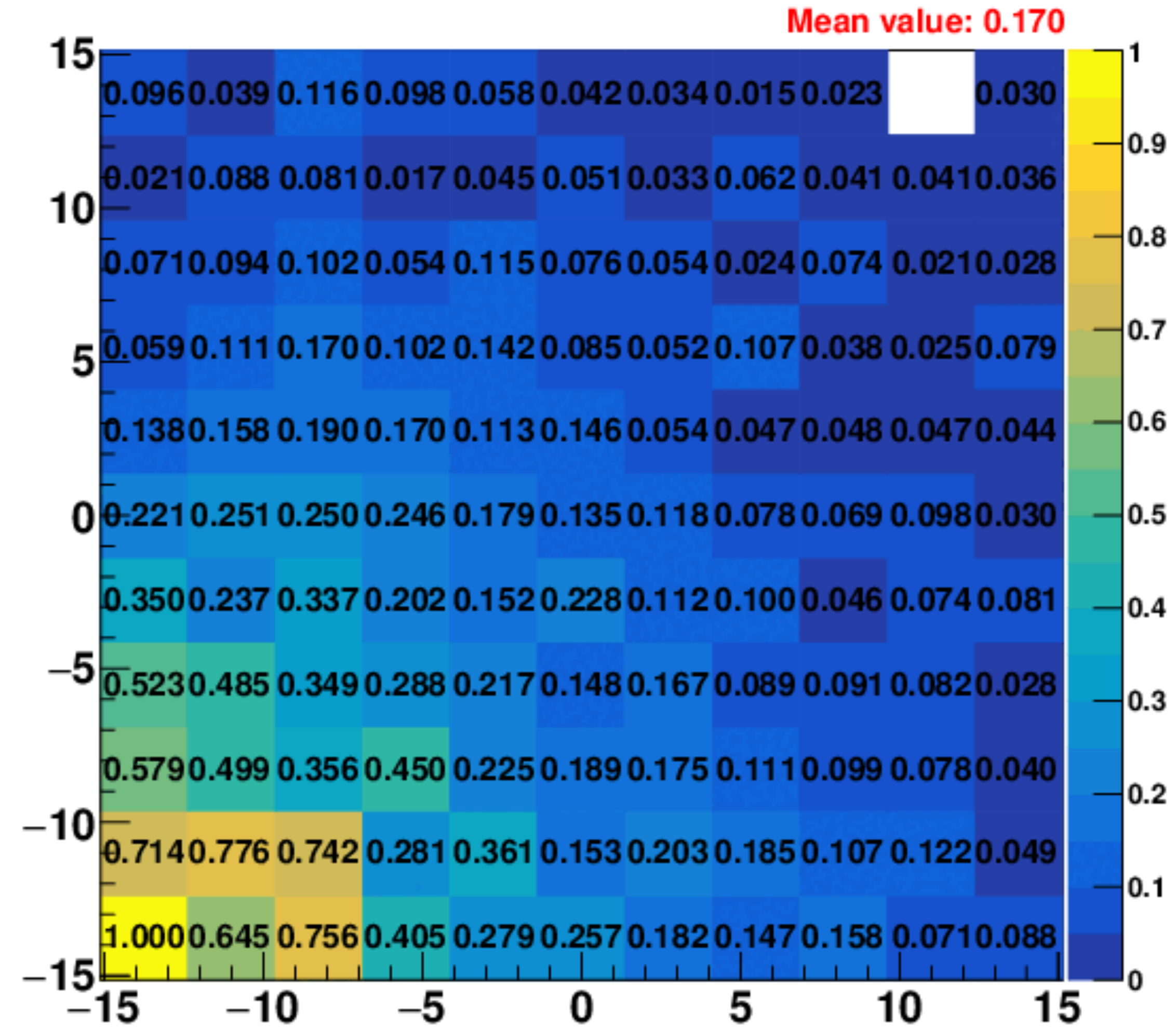

Geometry 4

AIR

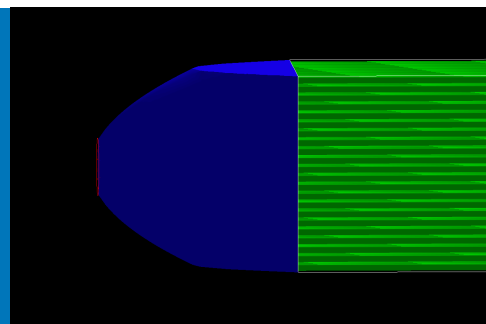

statistic 11.000 - muon 1 GeV

```
G4VSolid* coneS = new G4Paraboloid
("aPara", 0.5*PLEX_depth,PMT_radius,
0.5*sqrt(2)*(lguide_edge-2.0*airGap));
```

Winstone cone
PMT 4.5

Efficiency - LG - Air - 2cm - base round - 4.5 mm

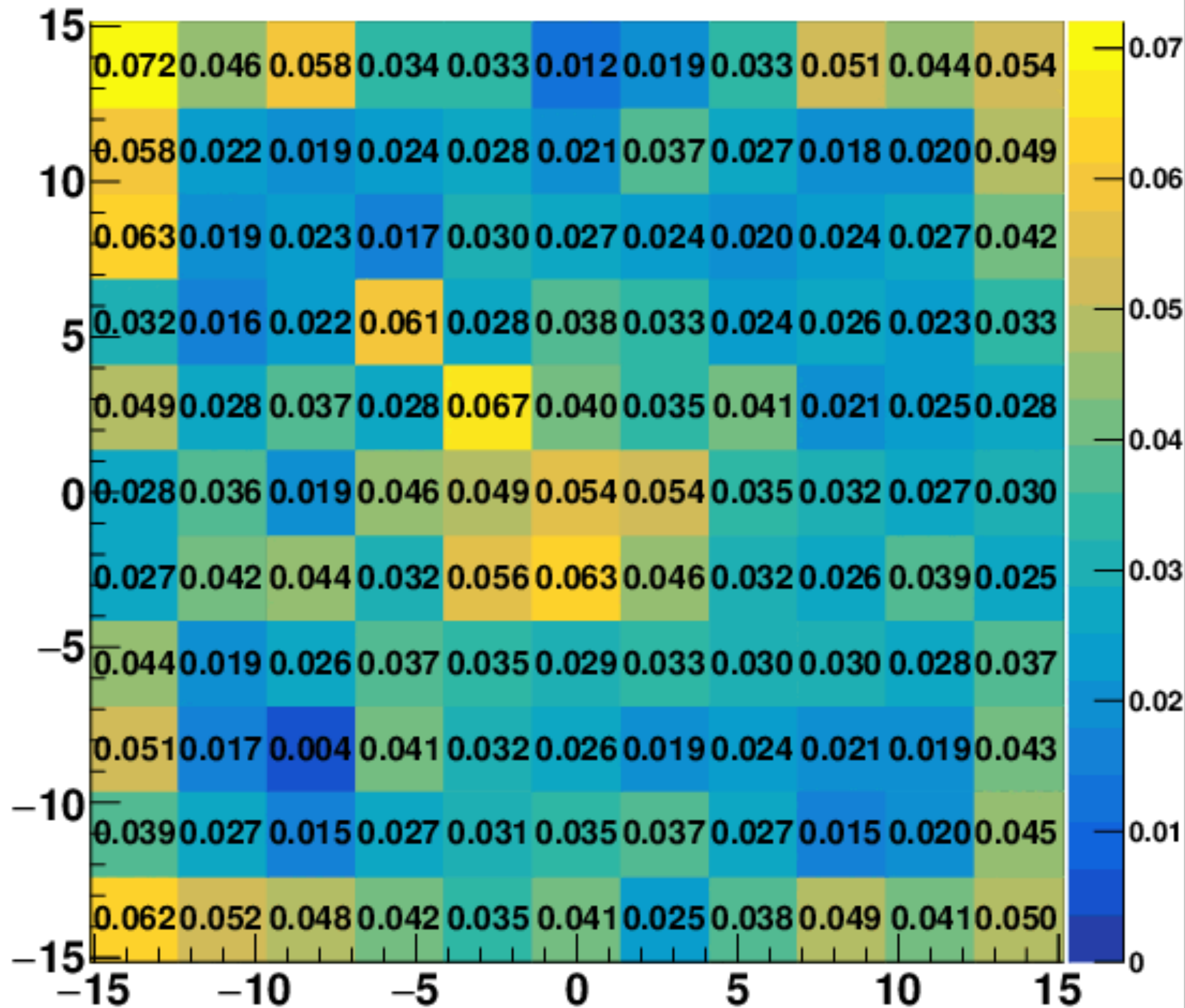

Factor non-uniformity - LG - Air - 2cm - base round - 4.5 mm

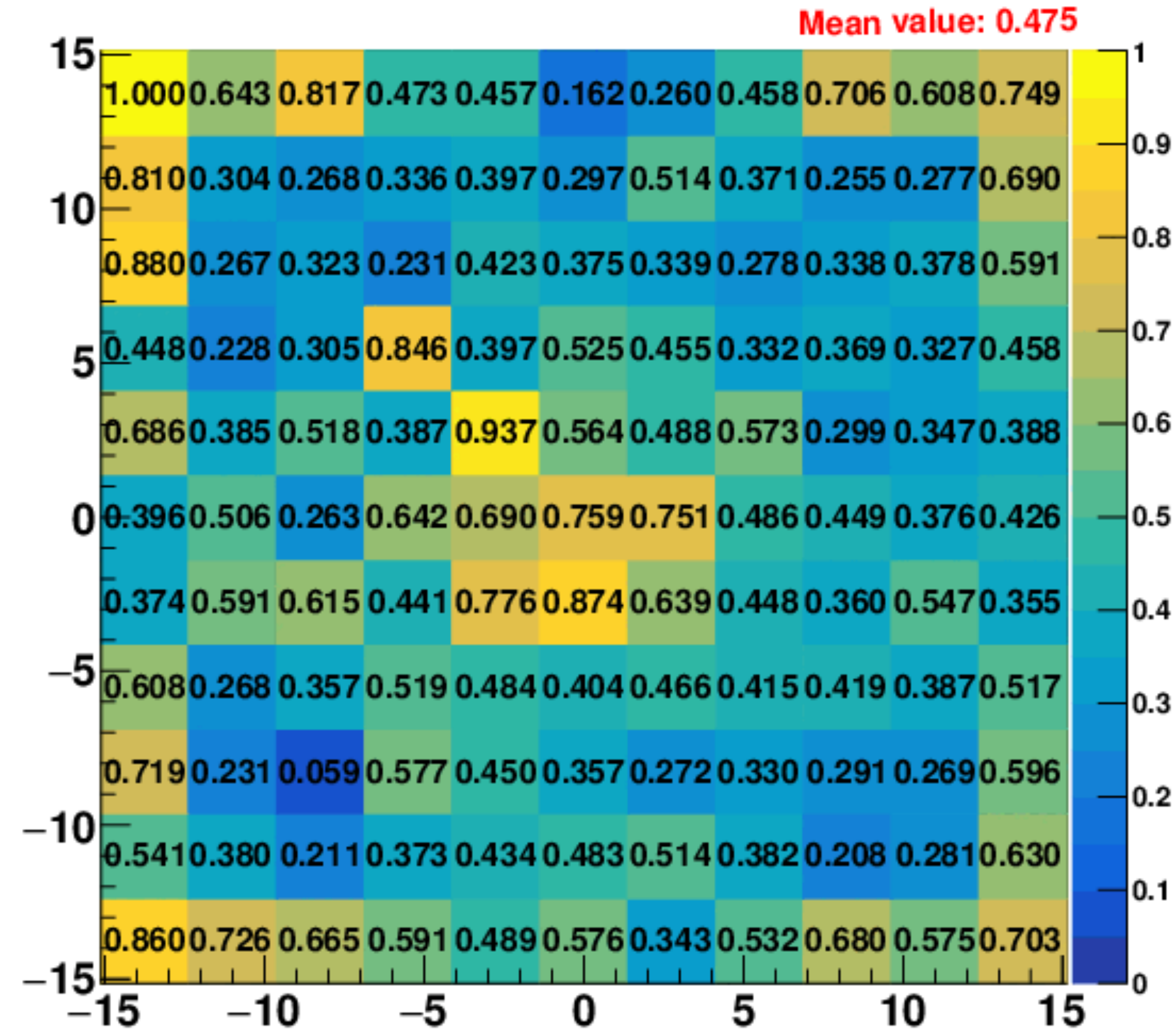

Geometry 5

PMMA

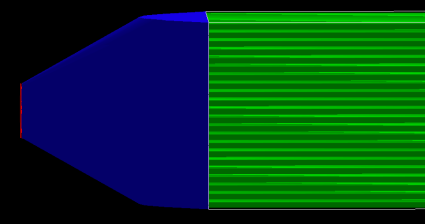

statistic 11.000 - muon 1 GeV

```
G4VSolid* coneS = new G4Paraboloid
("aPara", 0.5*PLEX_depth,PMT_radius,
0.5*sqrt(2)*(lguide_edge-2.0*airGap));
```

FISH TAIL
PMT 4.5

Efficiency - LG - PMMA - 2cm - base round - 4.5 mm

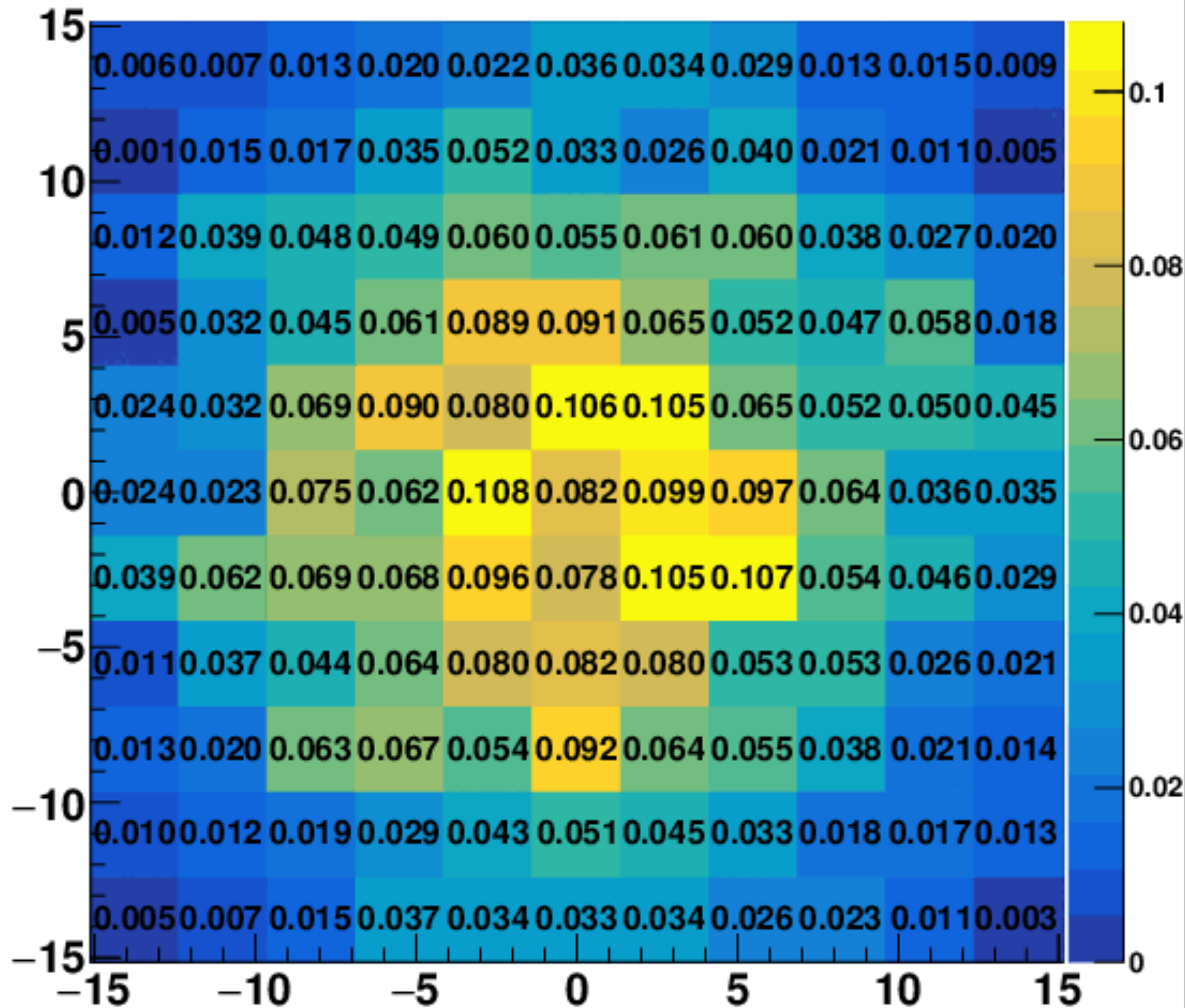

Factor non-uniformity - LG - PMMA - 2cm - base round - 4.5 mm

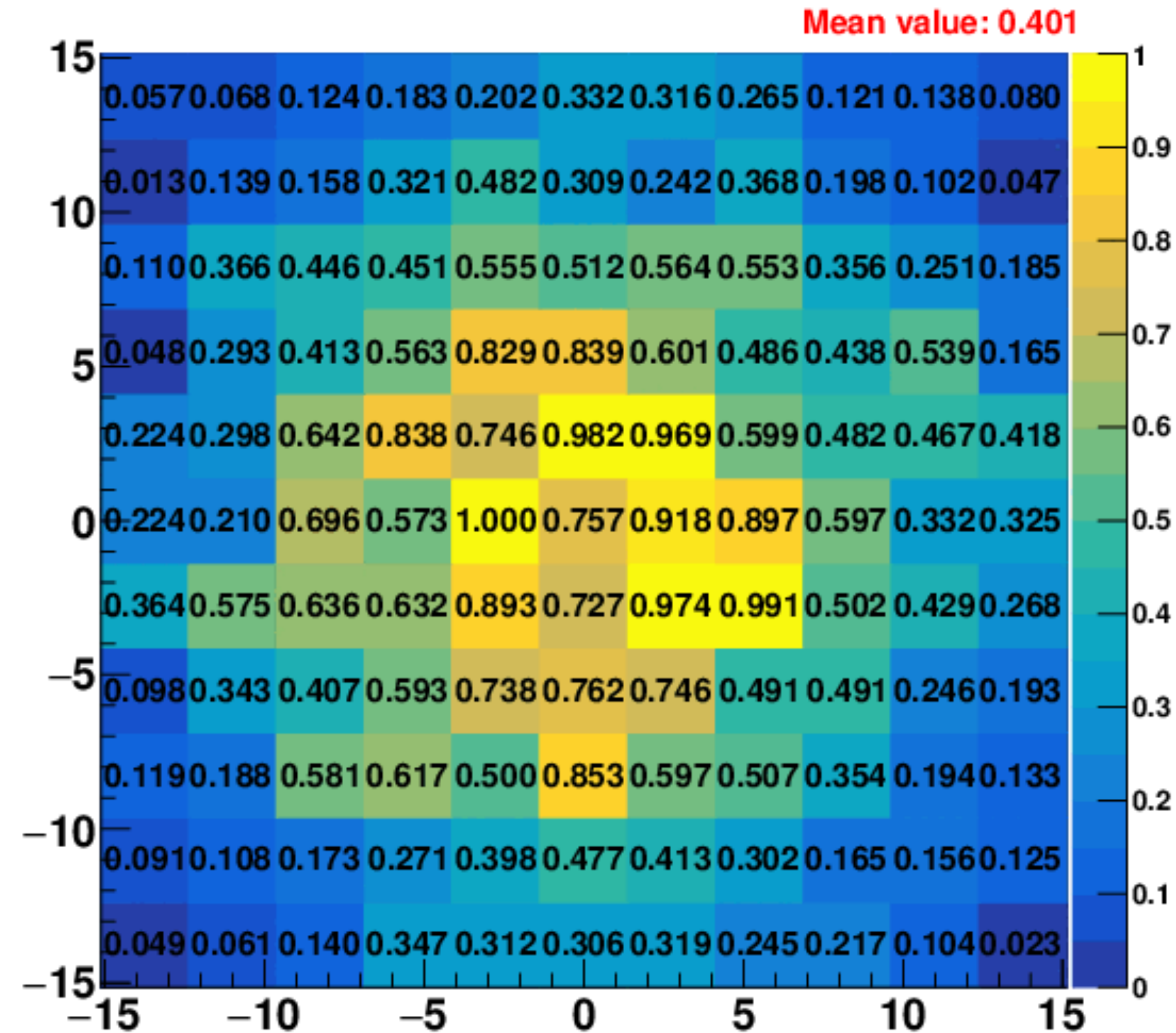

Geometry 5

AIR

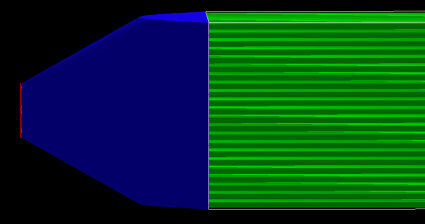

statistic 11.000 - muon 1 GeV

```
G4VSolid* coneS = new G4Paraboloid
("aPara", 0.5*PLEX_depth,PMT_radius,
0.5*sqrt(2)*(lguide_edge-2.0*airGap));
```

FISH TAIL
PMT 4.5

Efficiency - LG - Air - 2cm - base round - 4.5 mm

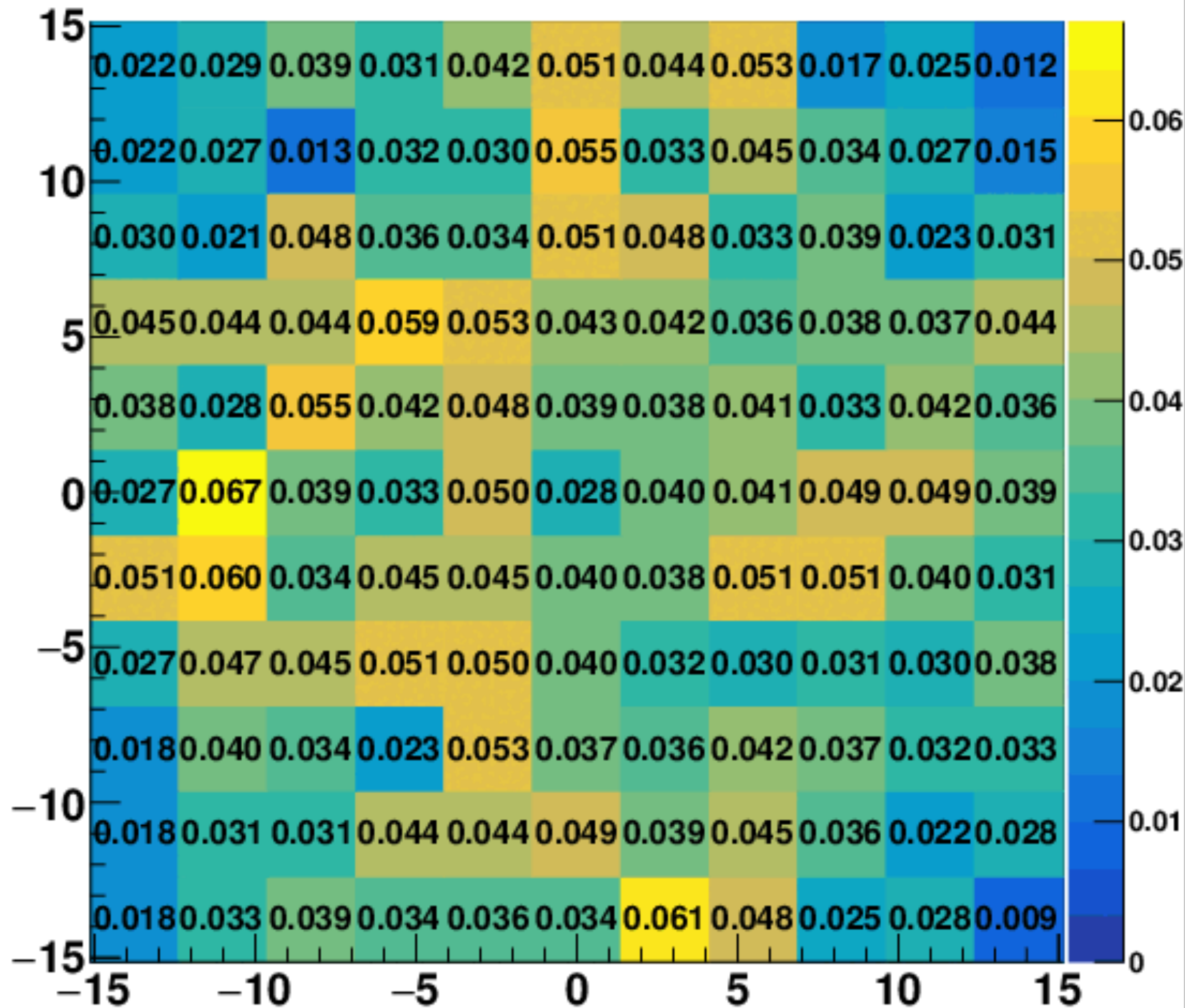

Factor non-uniformity - LG - Air - 2cm - base round - 4.5 mm

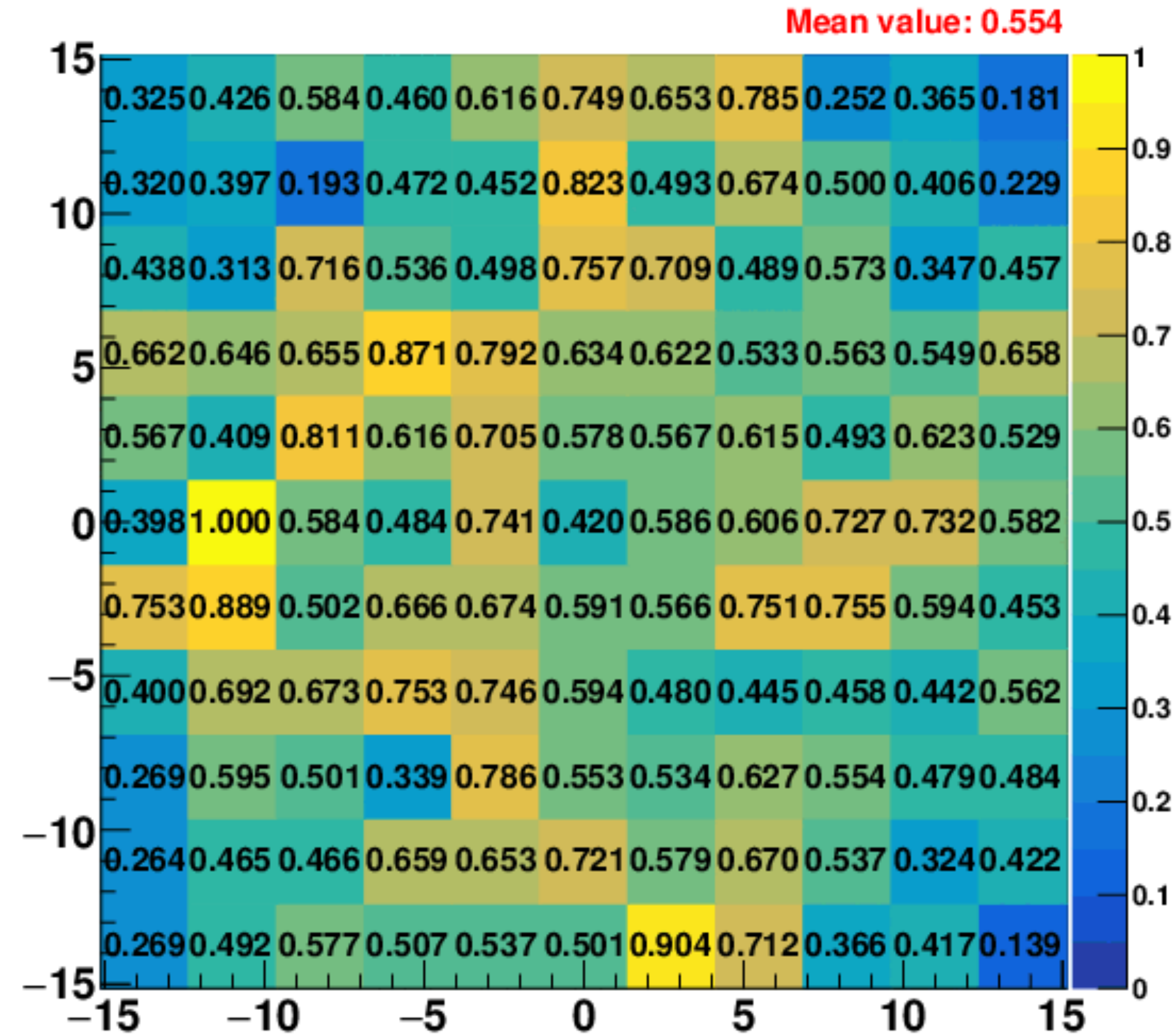

- **Geometry 6**

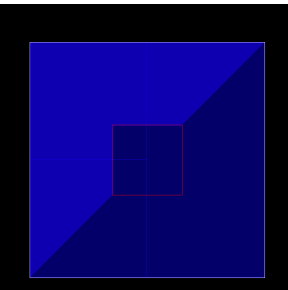

22x22 – Trap – 18 mm

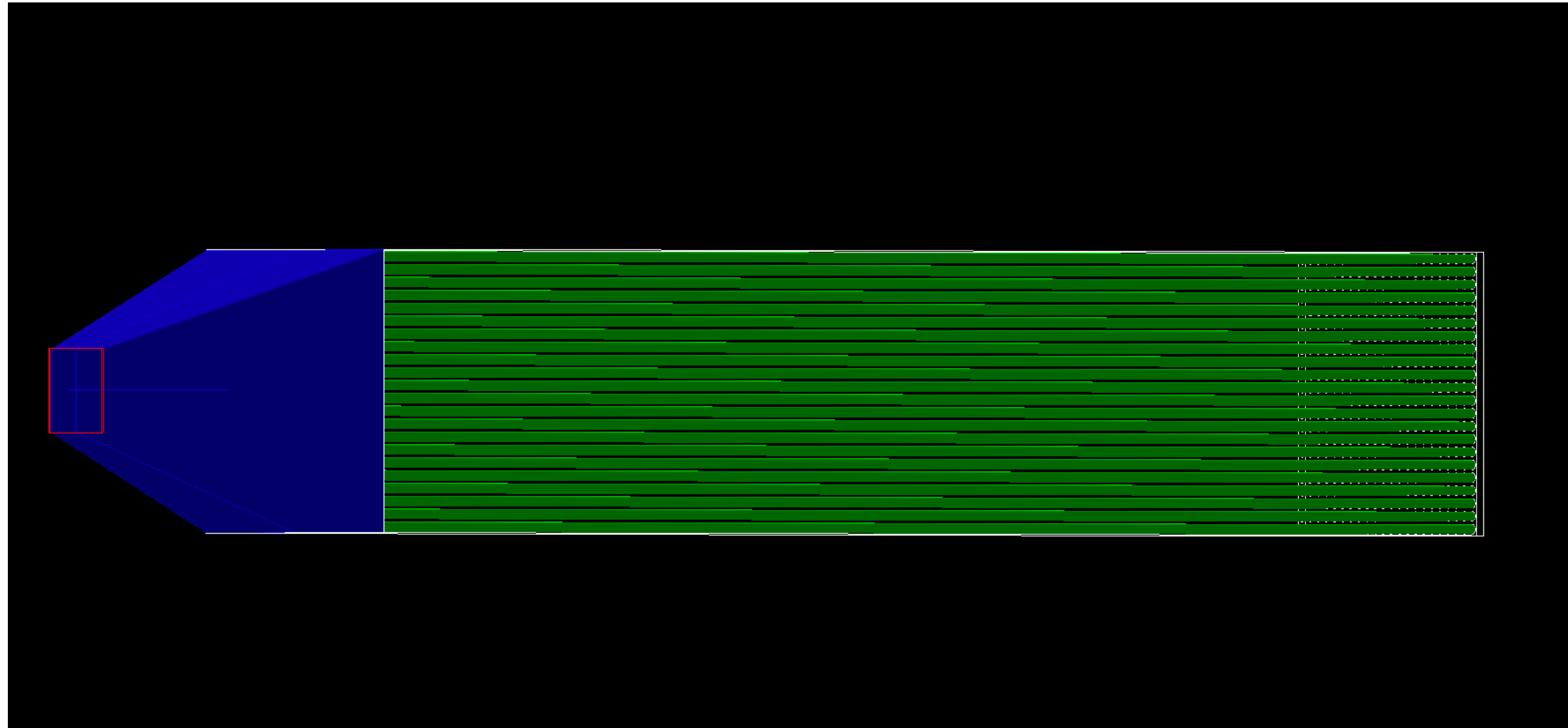
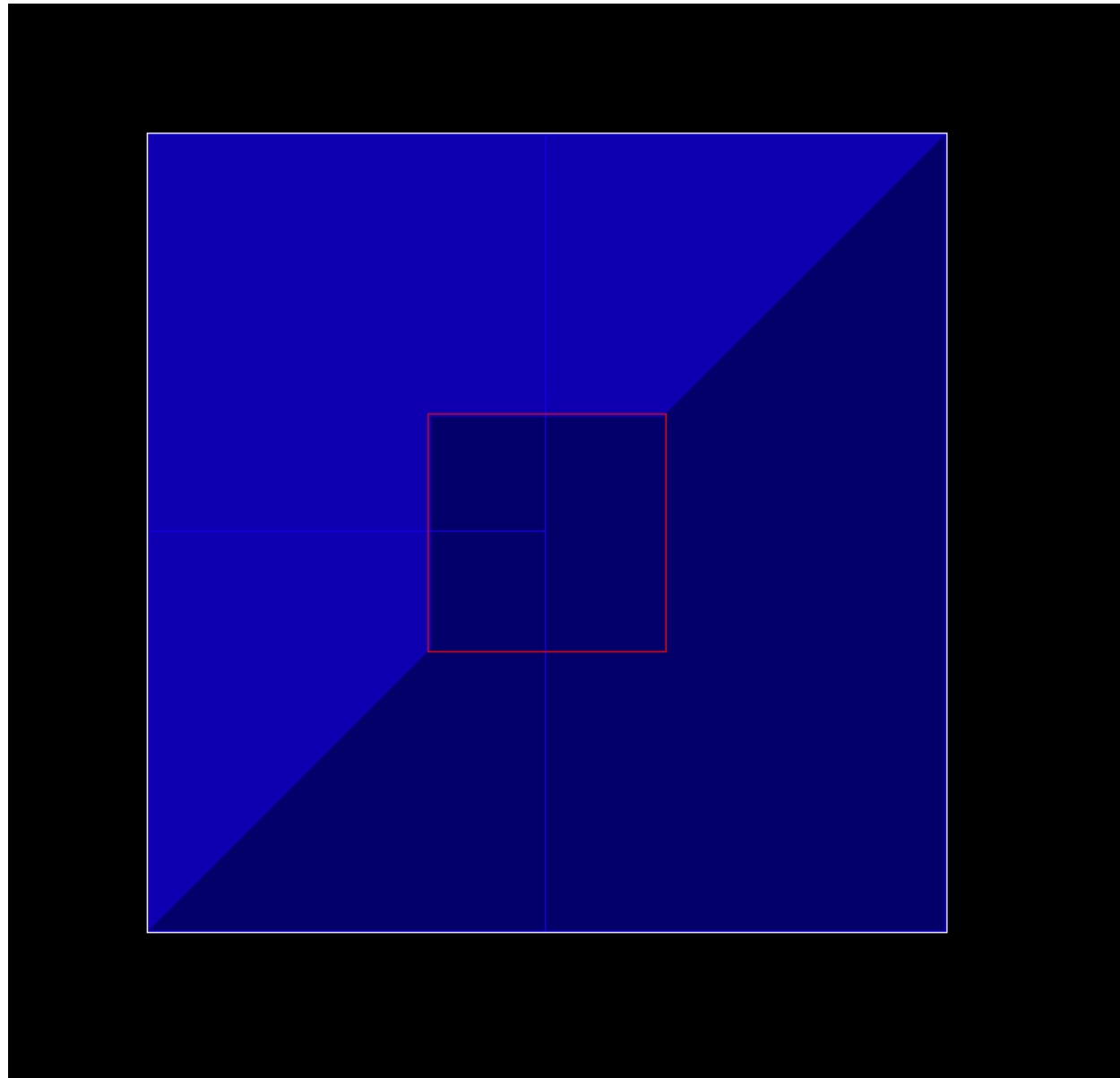

• Geometry 6

PMMA

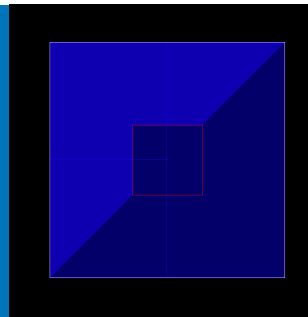

22x22 – Trap – 18 mm

Efficiency - LG - PMMA - 2cm - 22x22 - 18. mm

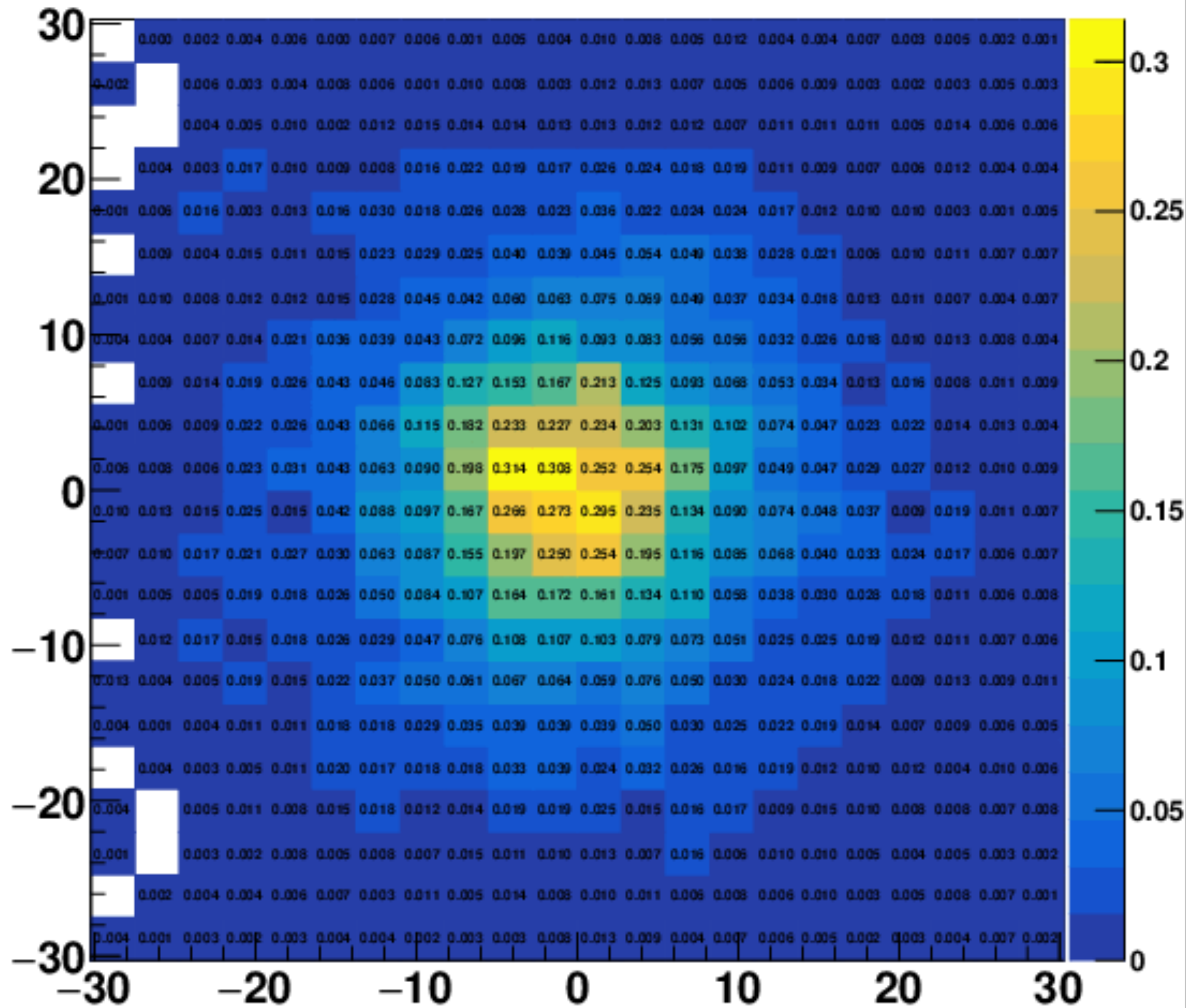

Factor non-uniformity - LG - PMMA - 2cm - 22x22 - 18. mm

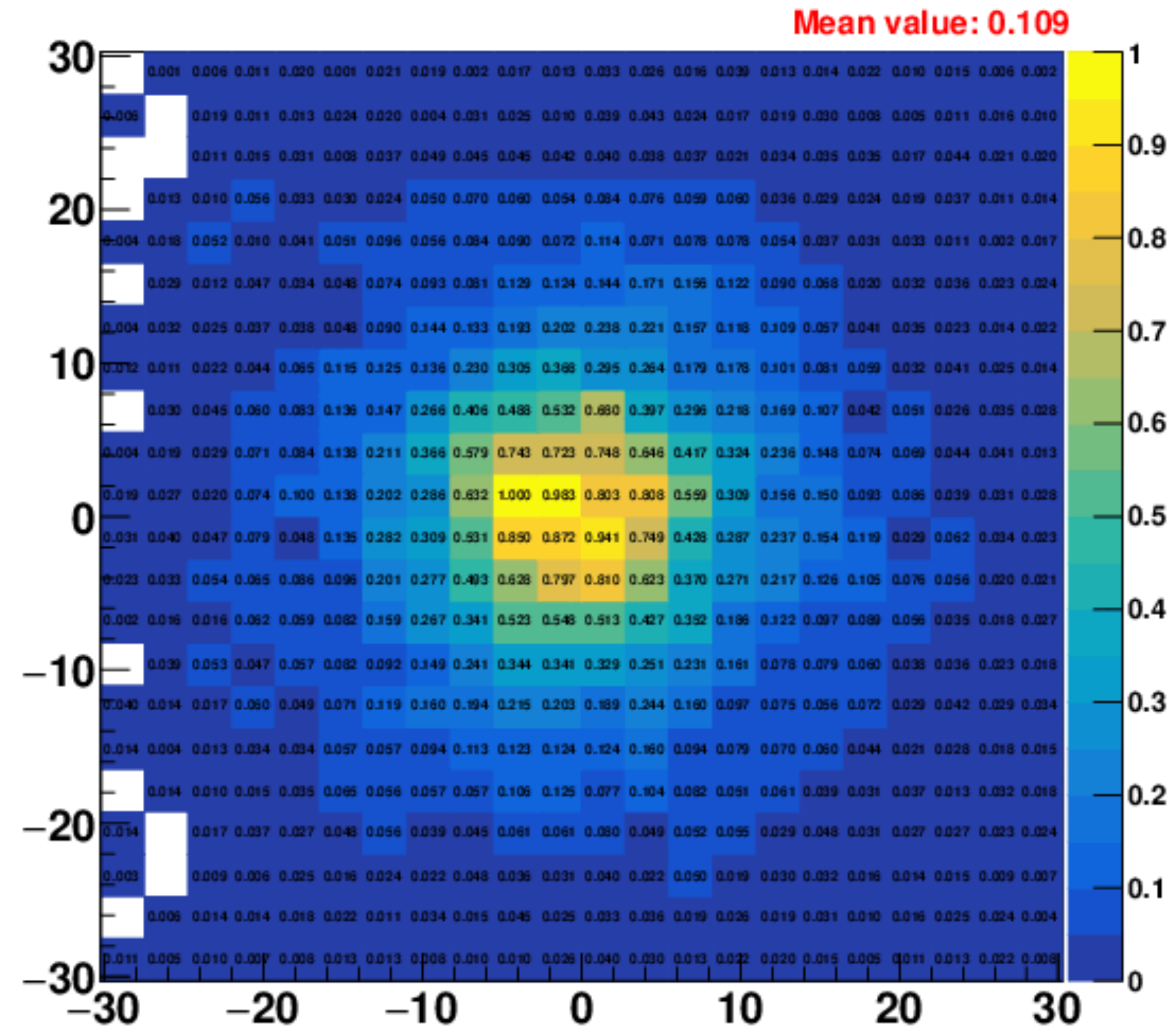

• Geometry 6

AIR

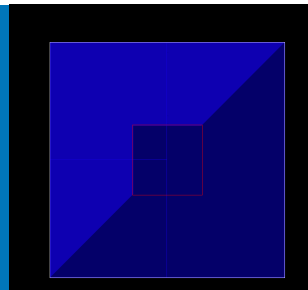

22x22 – Trap – 18 mm

Efficiency - LG - Air - 2cm - 22x22 - 18. mm

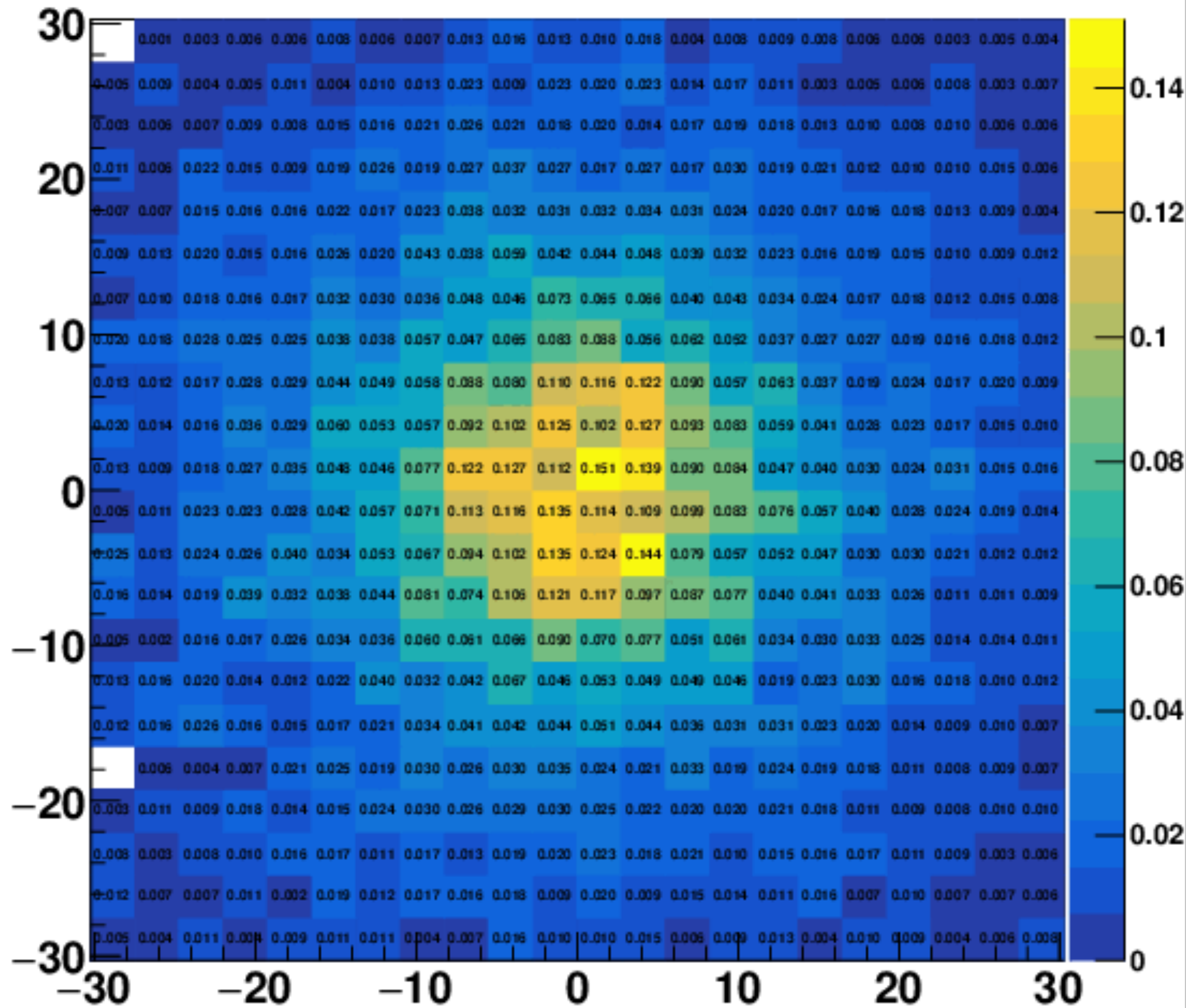

Factor non-uniformity - LG - Air - 2cm - 22x22 - 18. mm

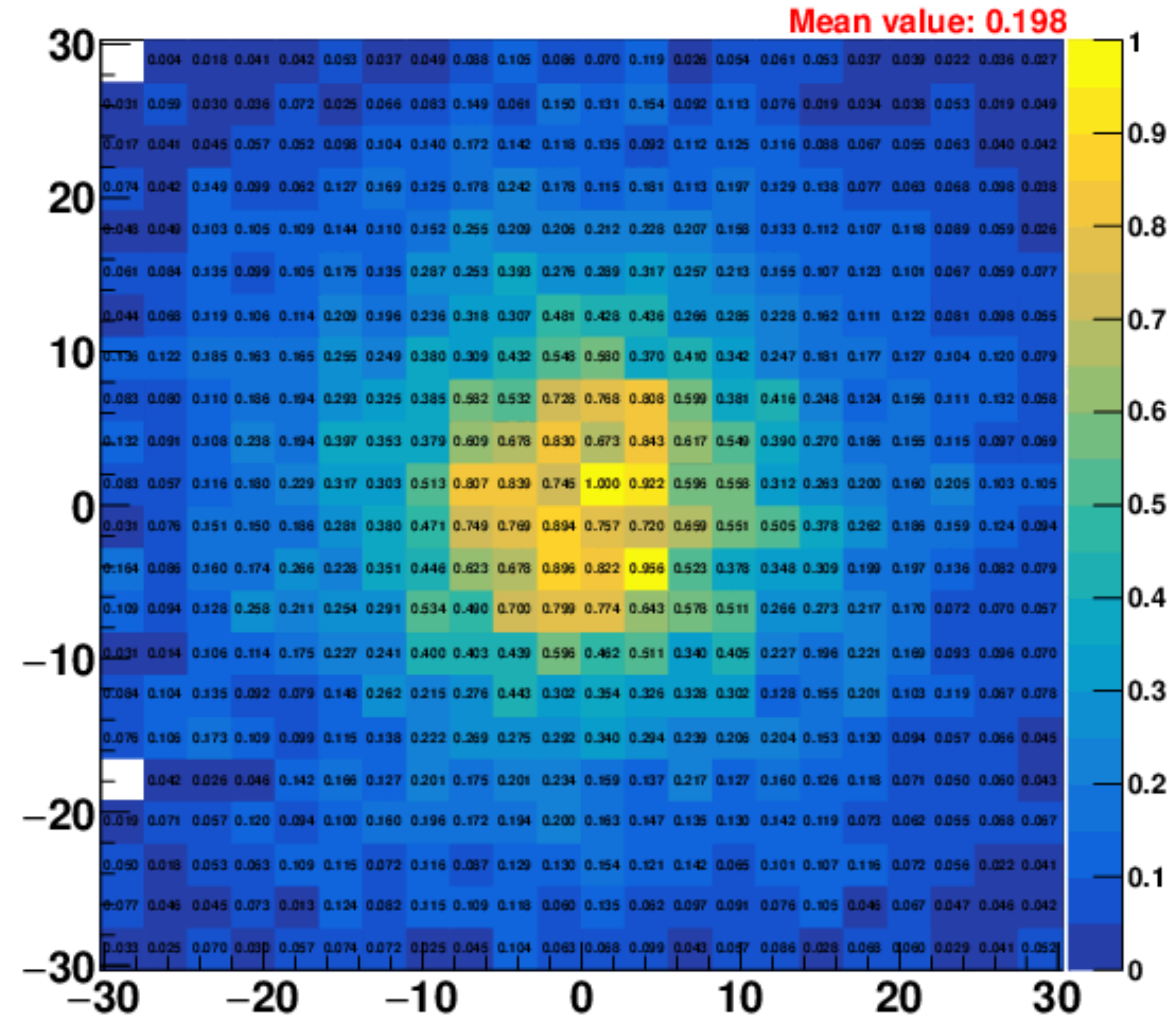

old slides

КОЛИЧЕСТВО

Fiber 1 Energy Deposition

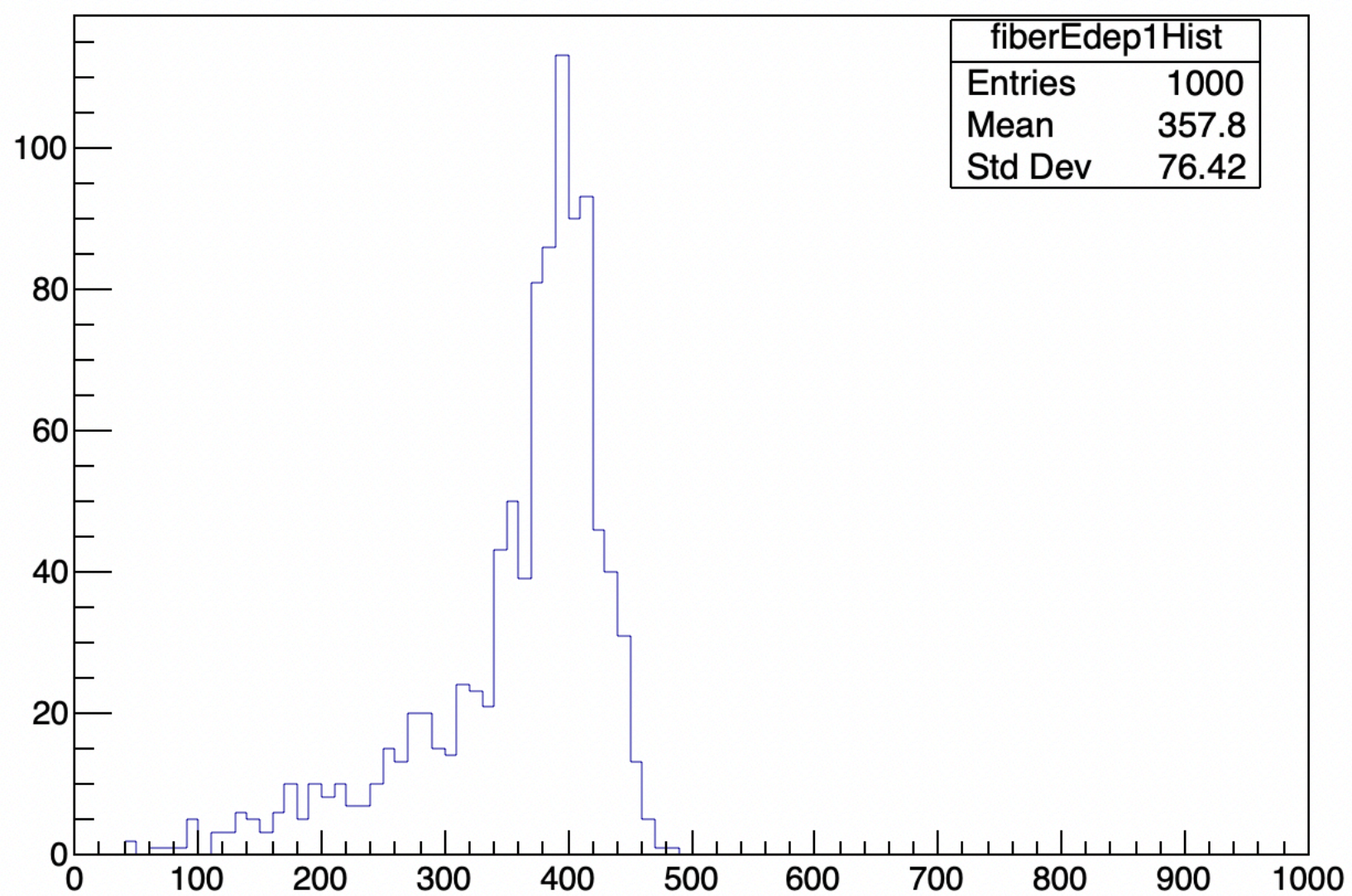

Fiber 2 Energy Deposition

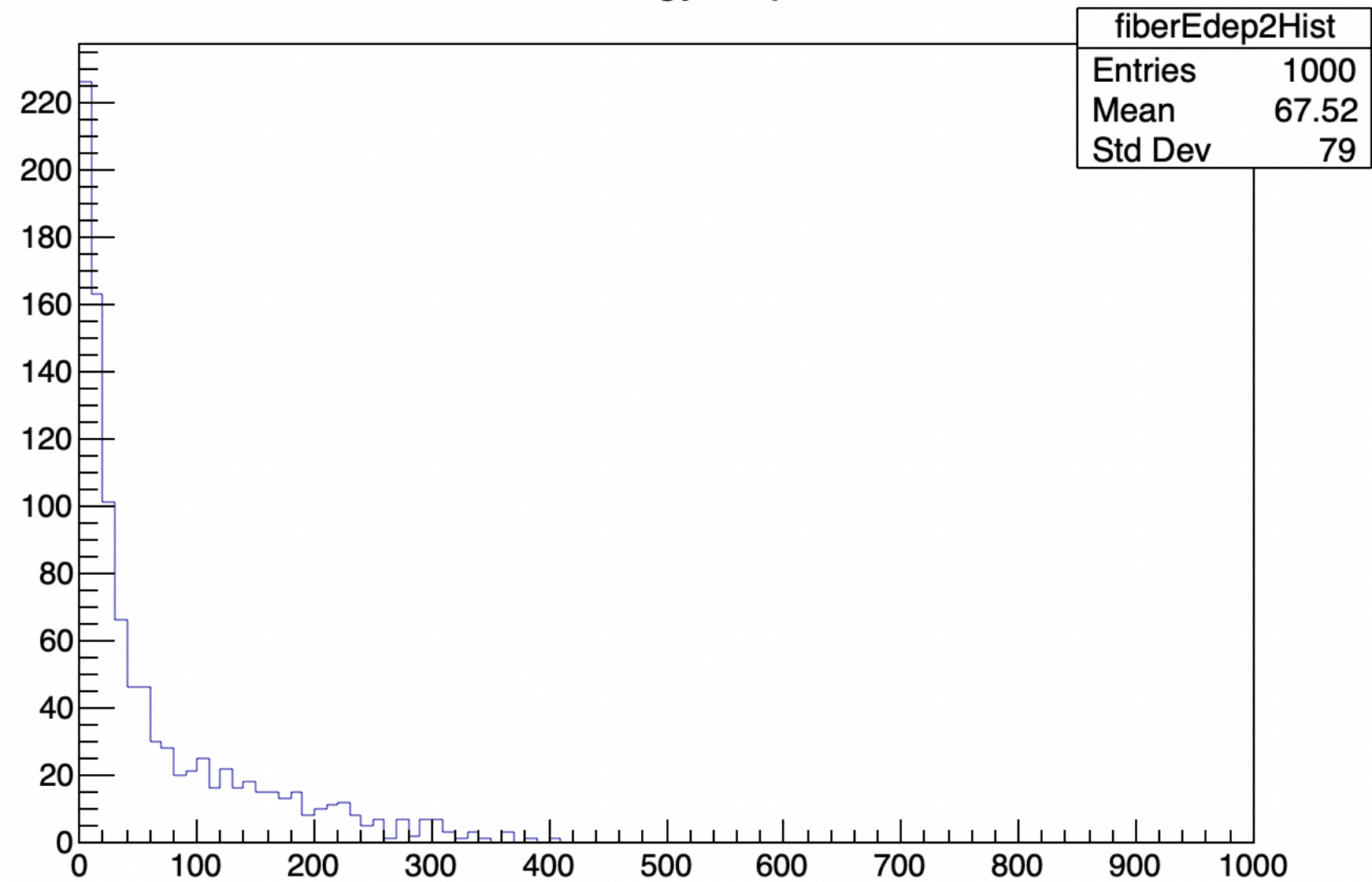

10 GeV electron

electrons
pions

Absorber 1 Energy Deposition

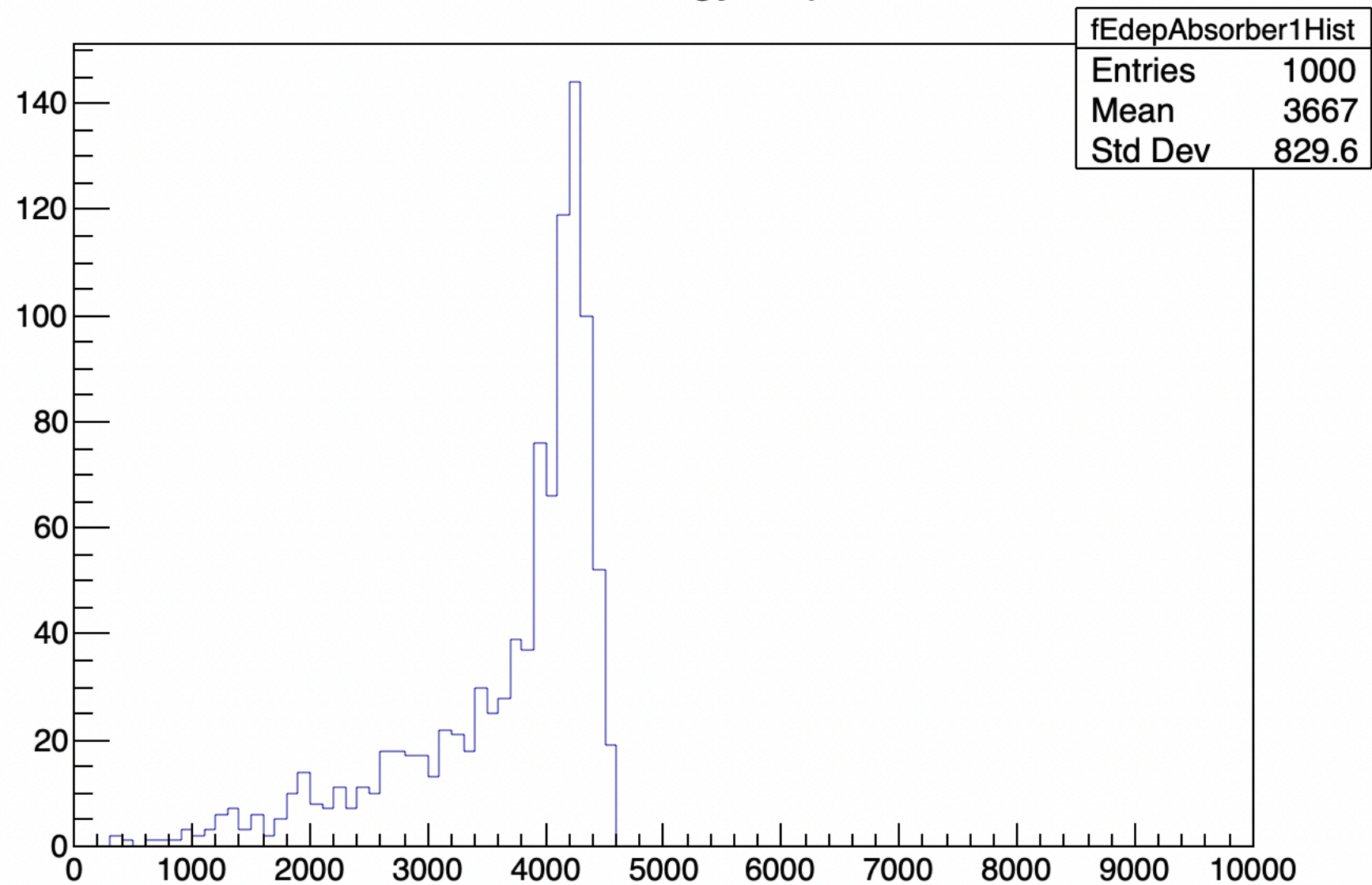

Absorber 2 Energy Deposition

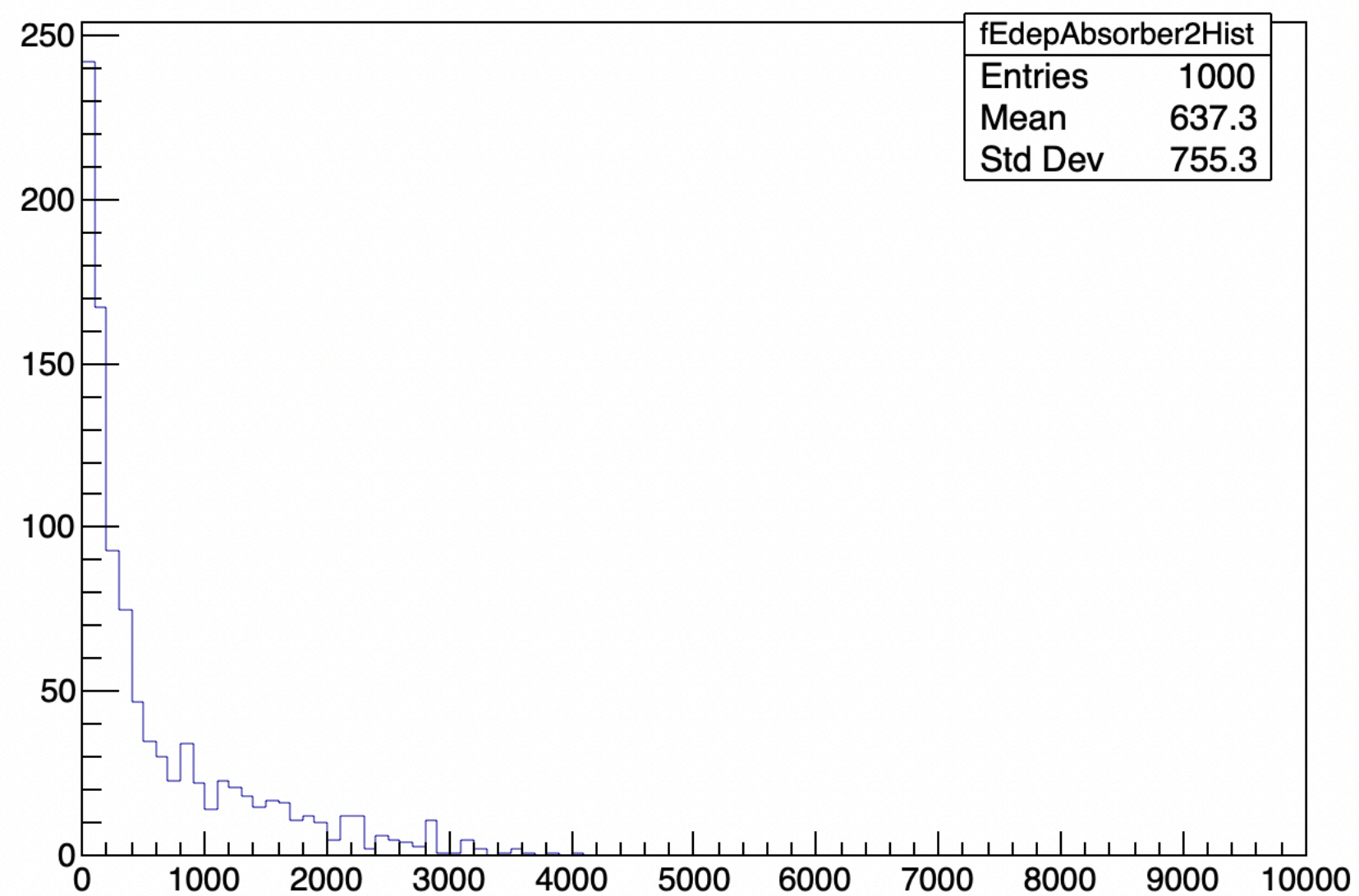

Fiber 1 Number of photons that reached PMT1

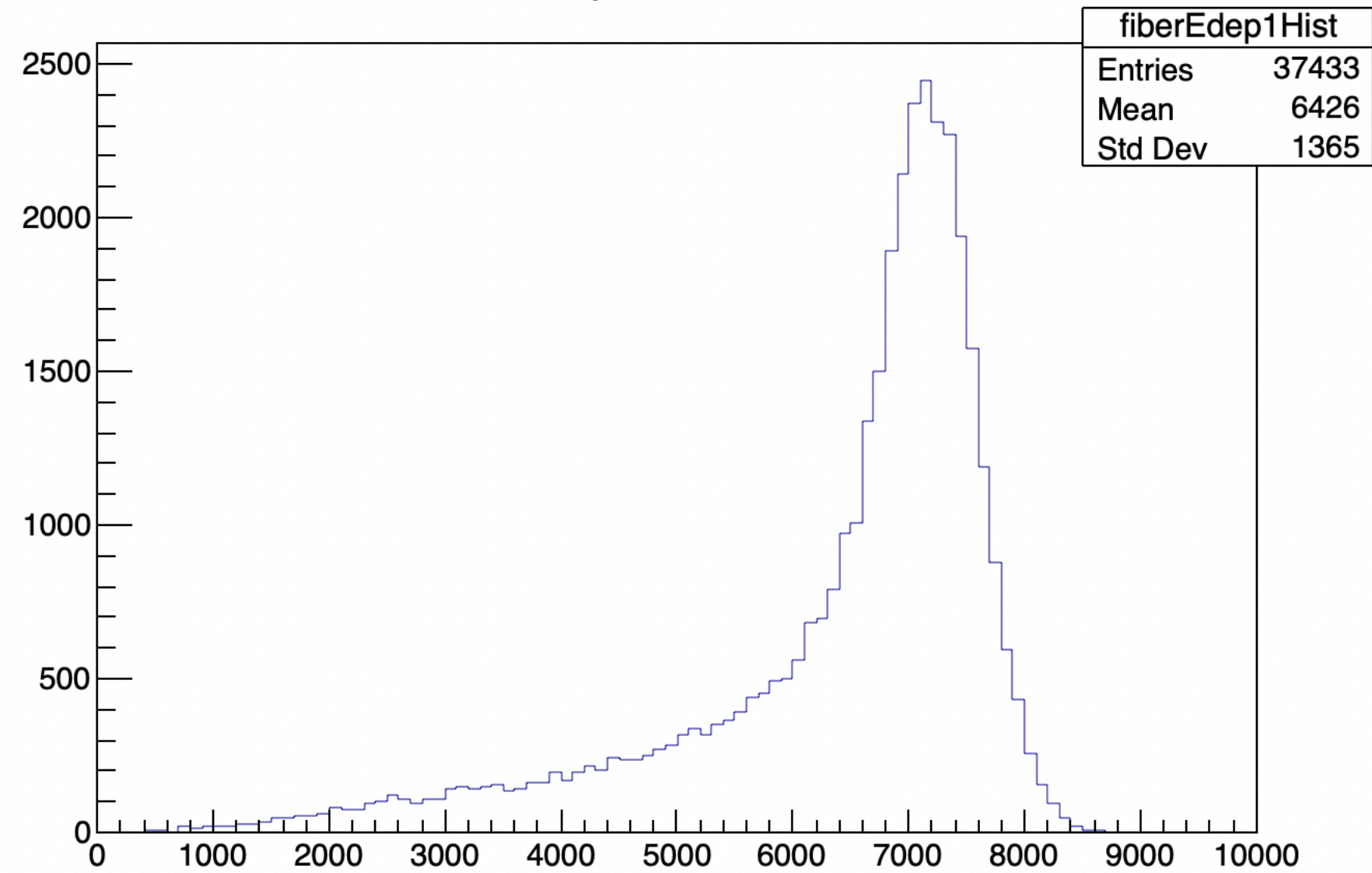

Fiber 2 Number of photons that reached PMT2

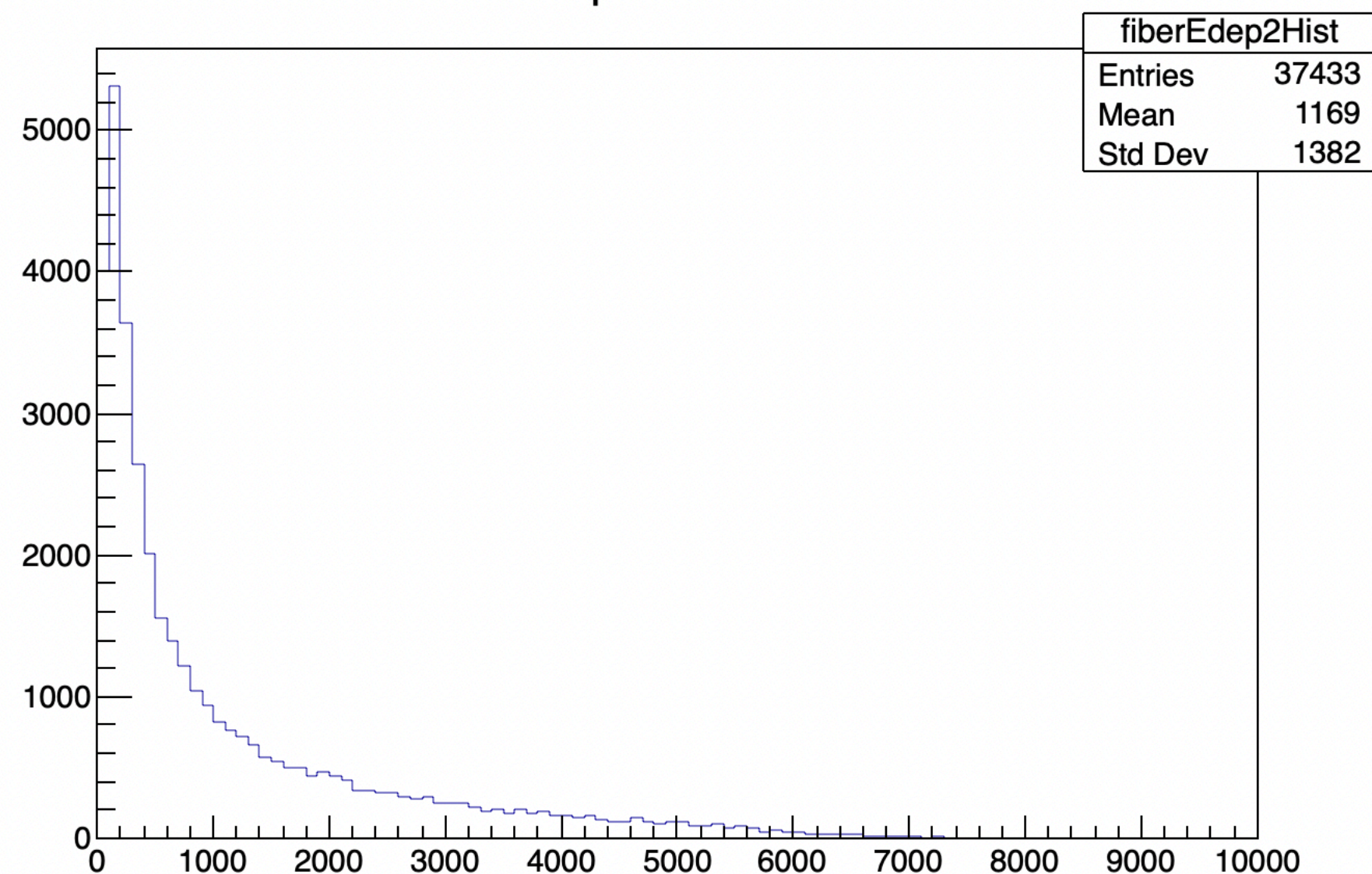

10 GeV electron

Absorber 1 Energy Deposition

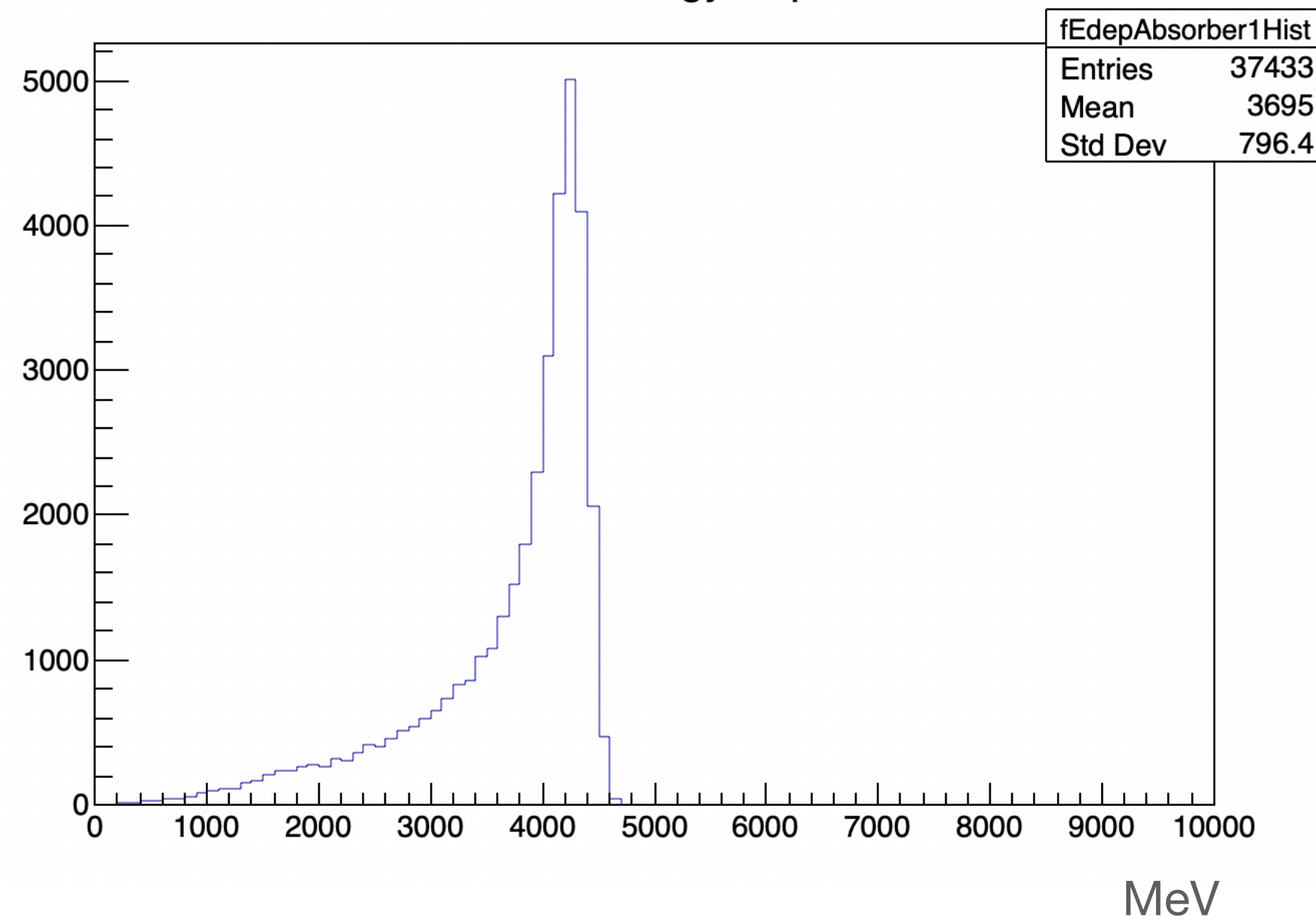

Absorber 2 Energy Deposition

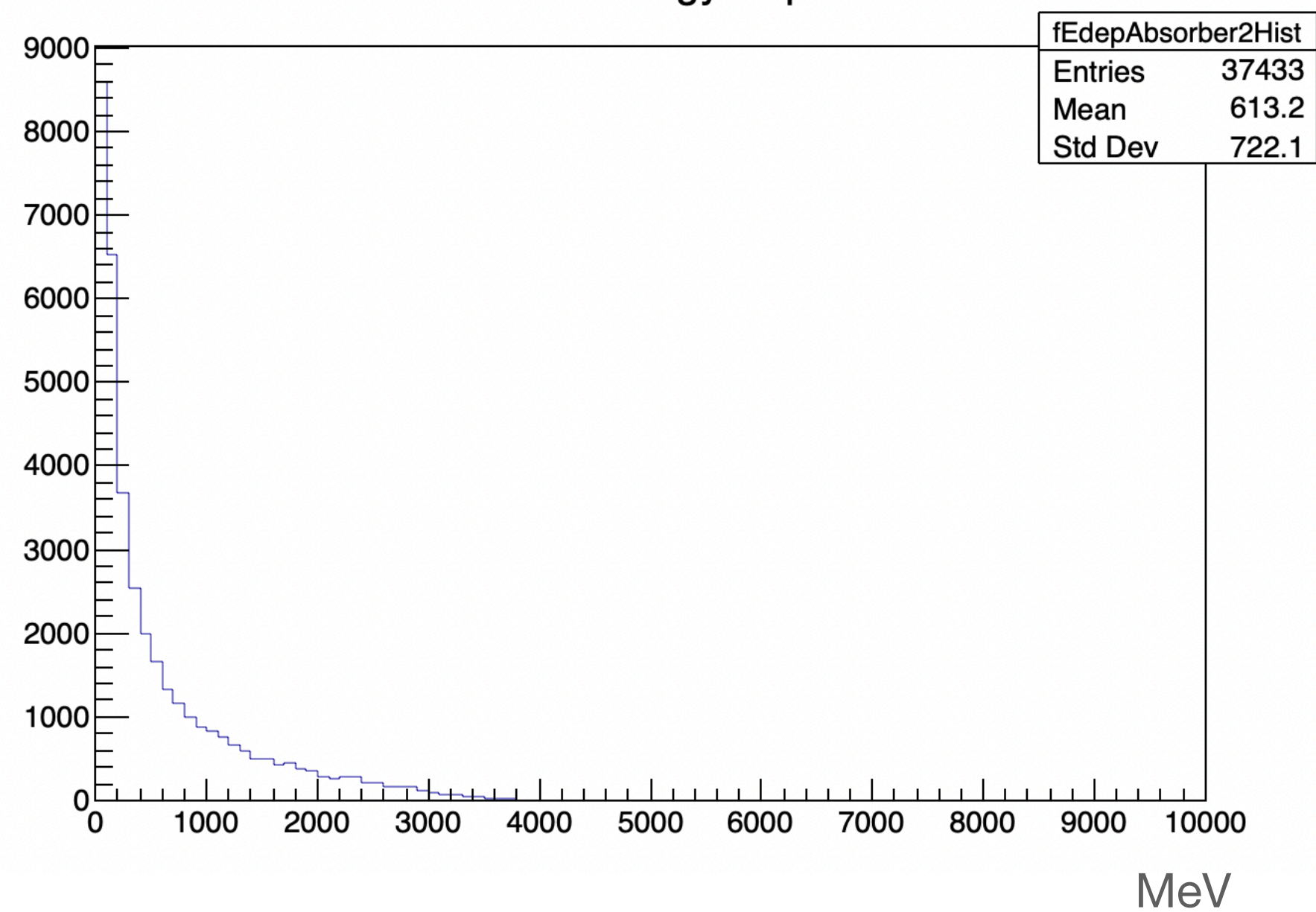

Fiber 1 Number of photons that reached PMT1

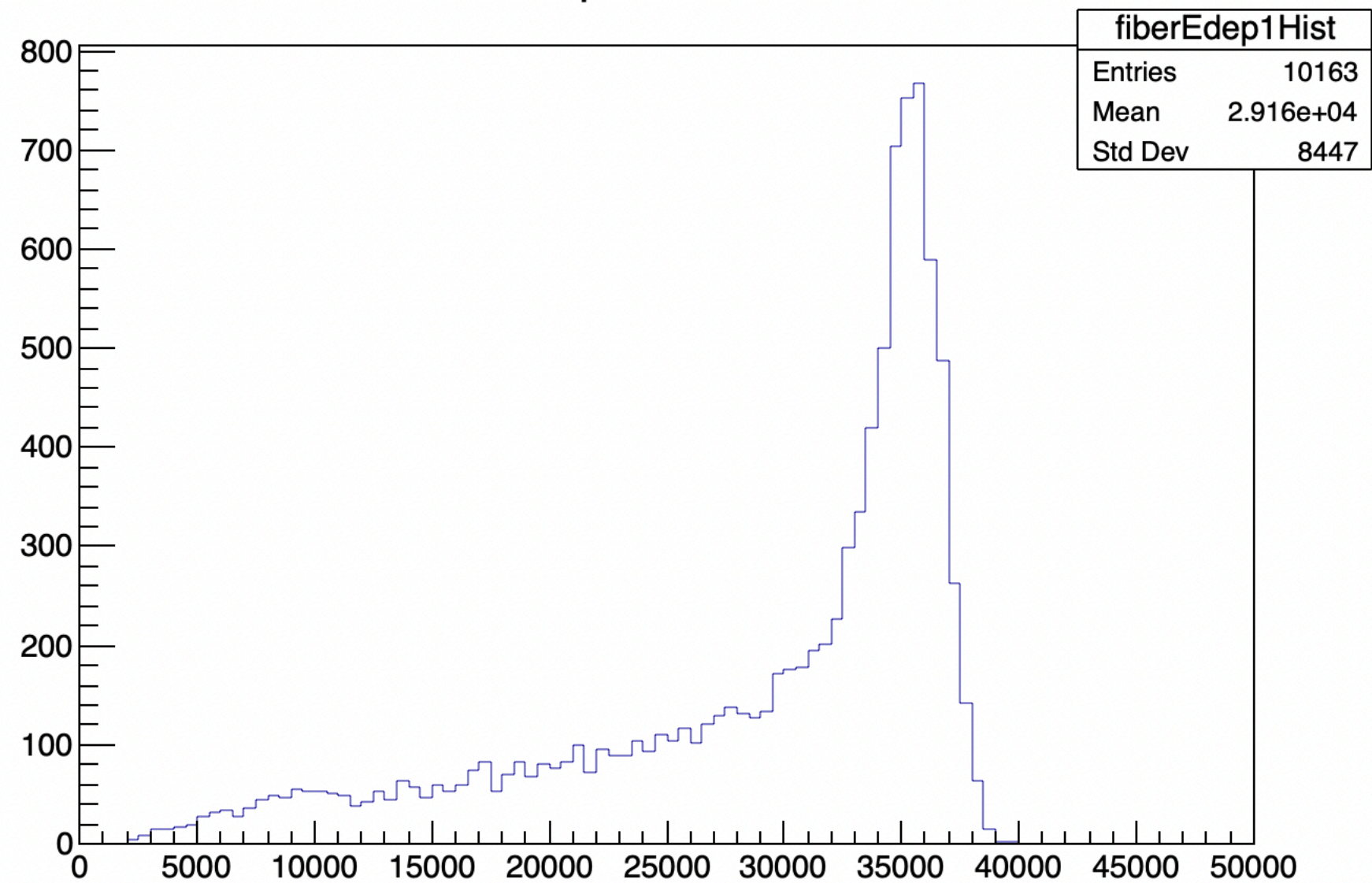

Fiber 2 Number of photons that reached PMT2

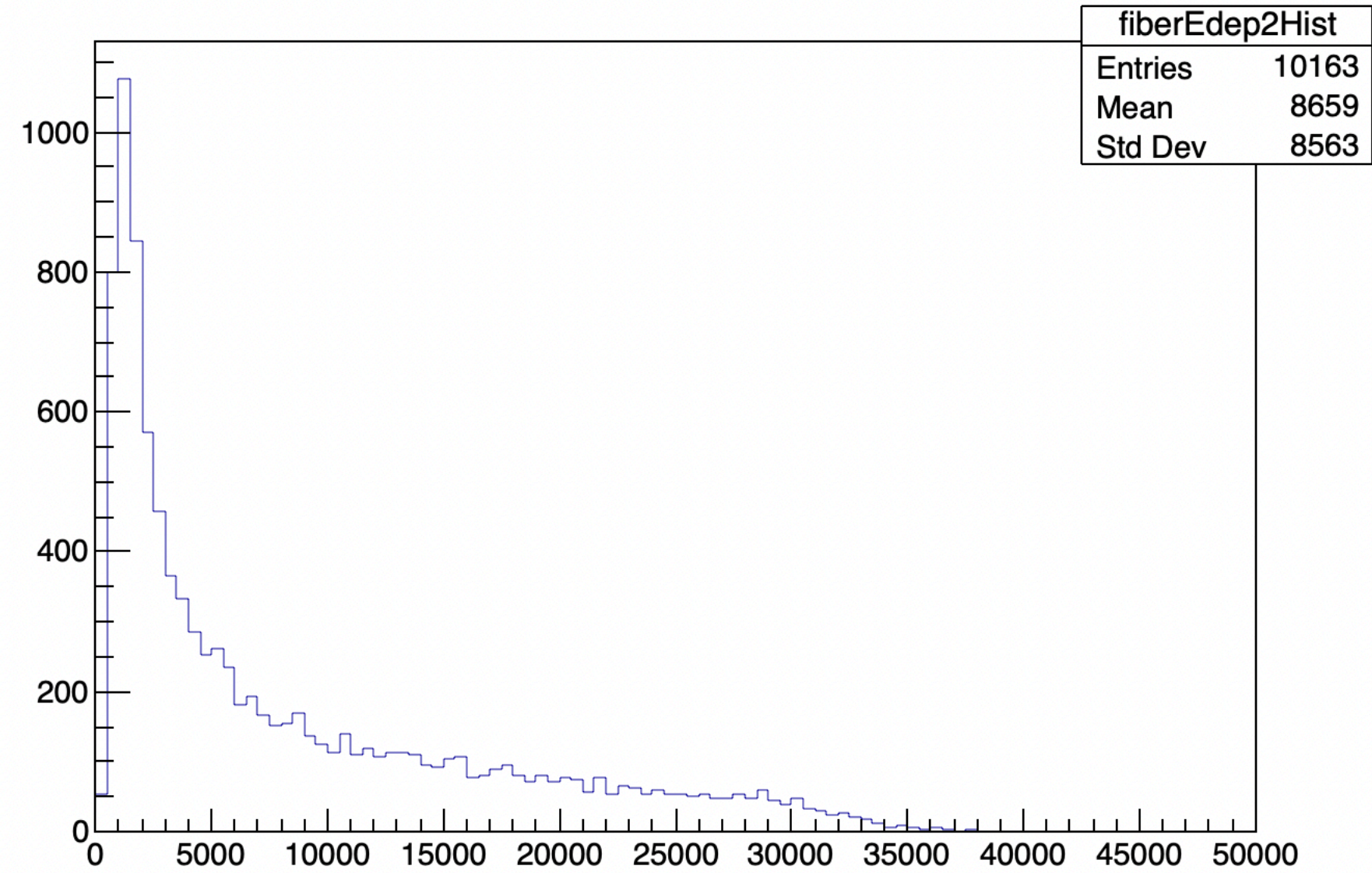

50 GeV electron

Absorber 1 Energy Deposition

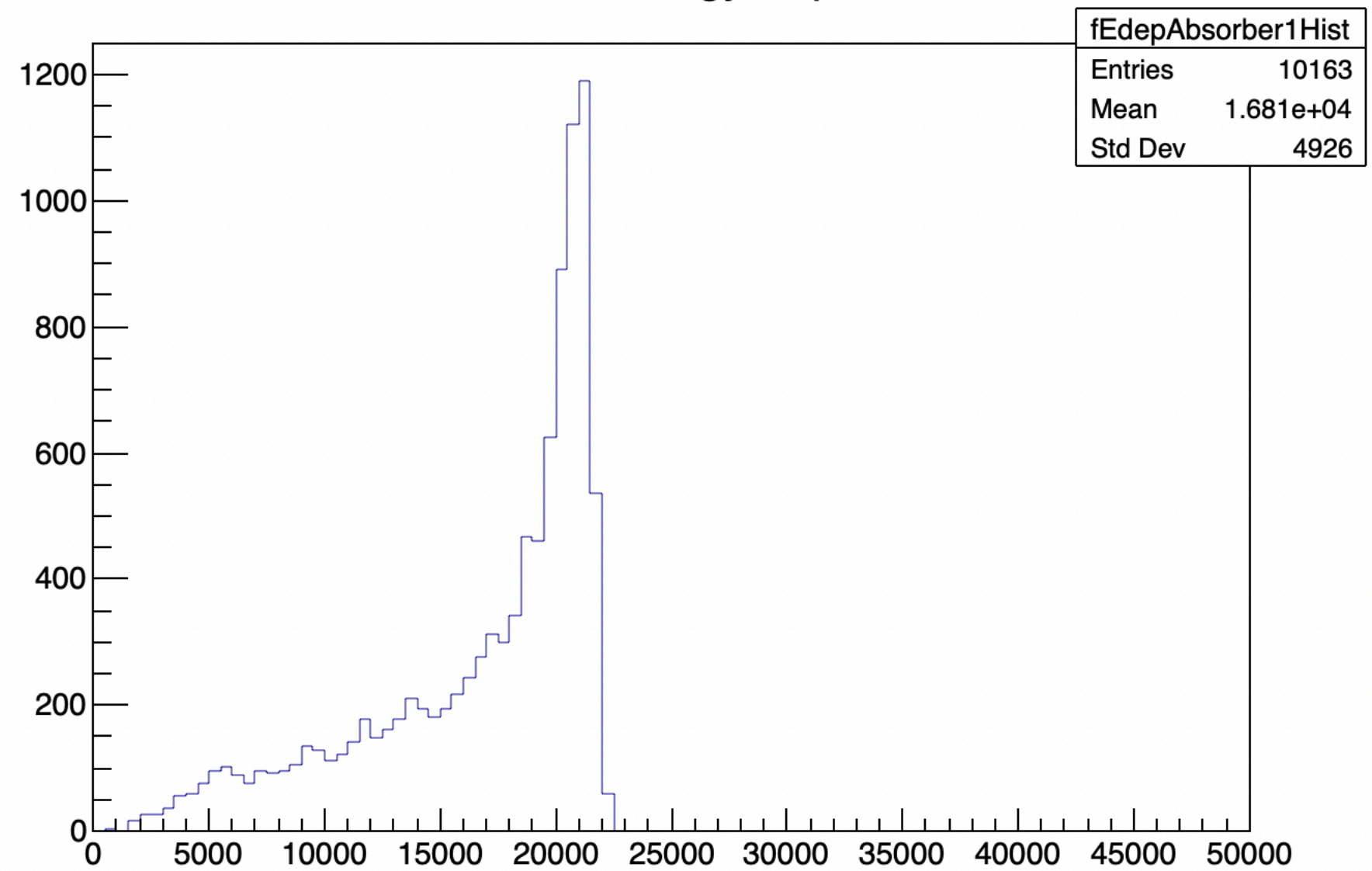

MeV

Absorber 2 Energy Deposition

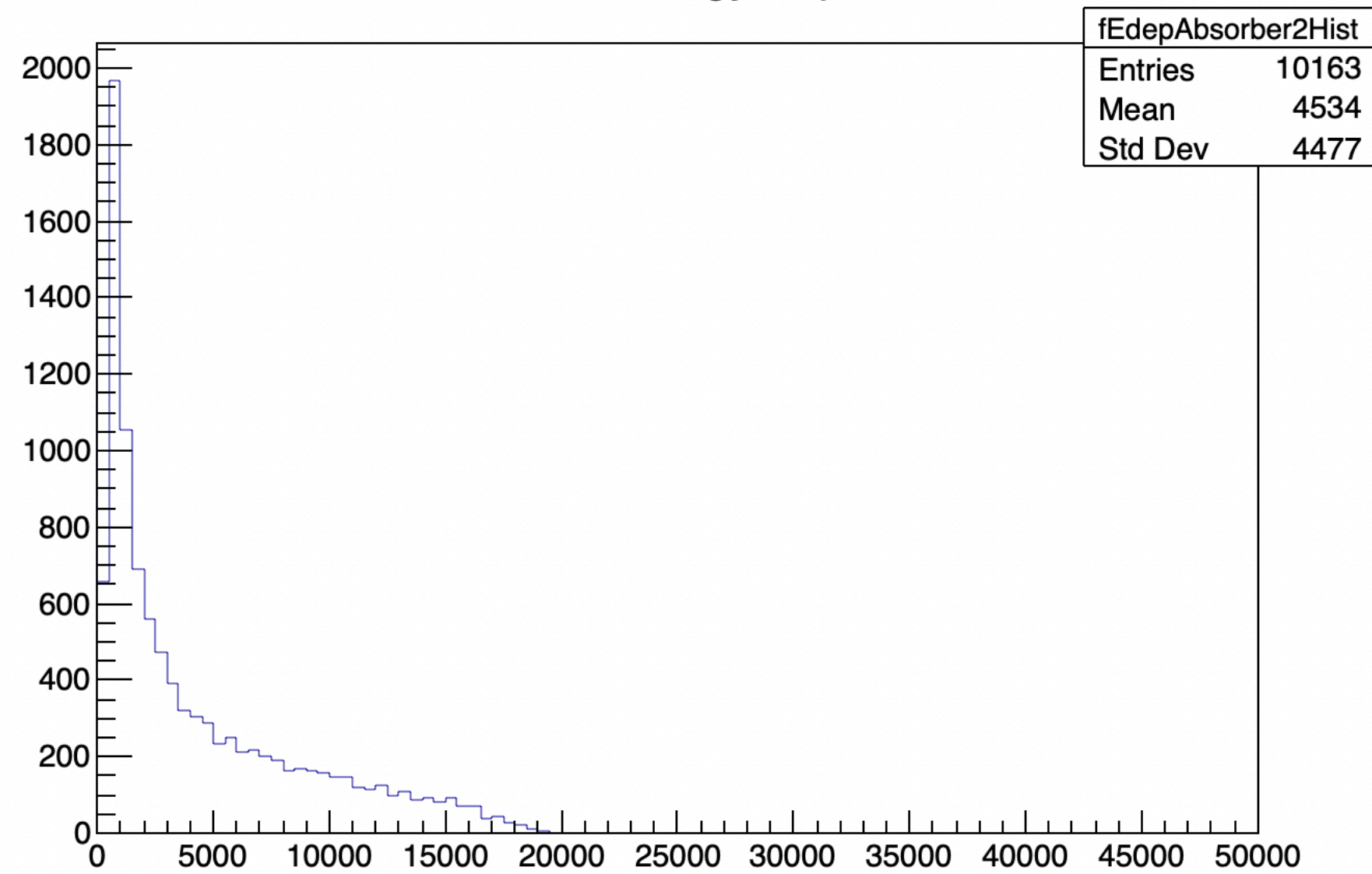

MeV

Graph

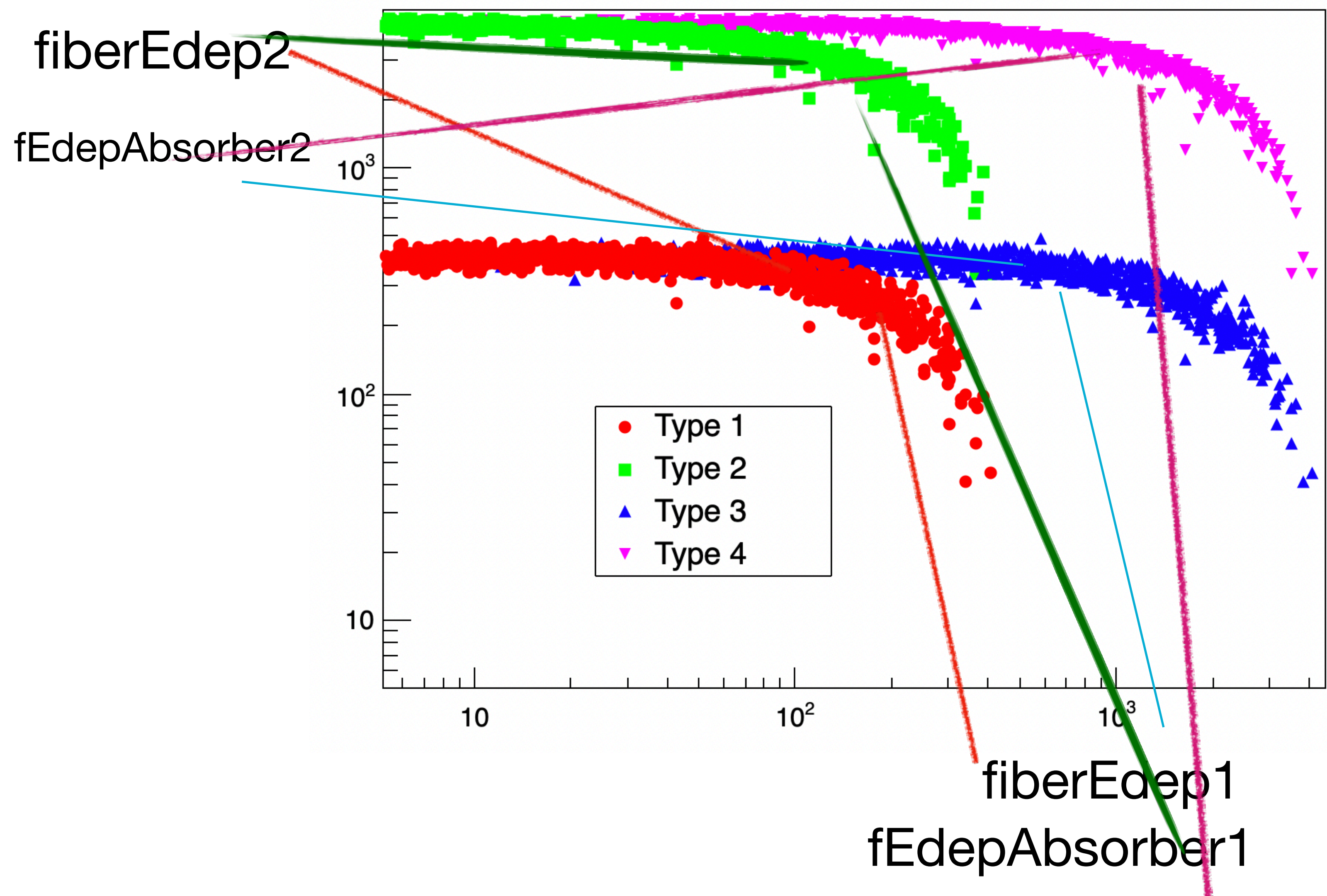

```
graph1>SetPoint( fiberEdep1,  
fiberEdep2);
```

```
graph2>SetPoint(fEdepAbsor  
ber1, fiberEdep2);
```

```
graph3>SetPoint( fiberEdep1,  
fEdepAbsorber2);
```

```
graph4>SetPoint( fEdepAbsor  
ber1, fEdepAbsorber2);
```

Graph

- Type 1
- Type 2
- Type 3
- Type 4

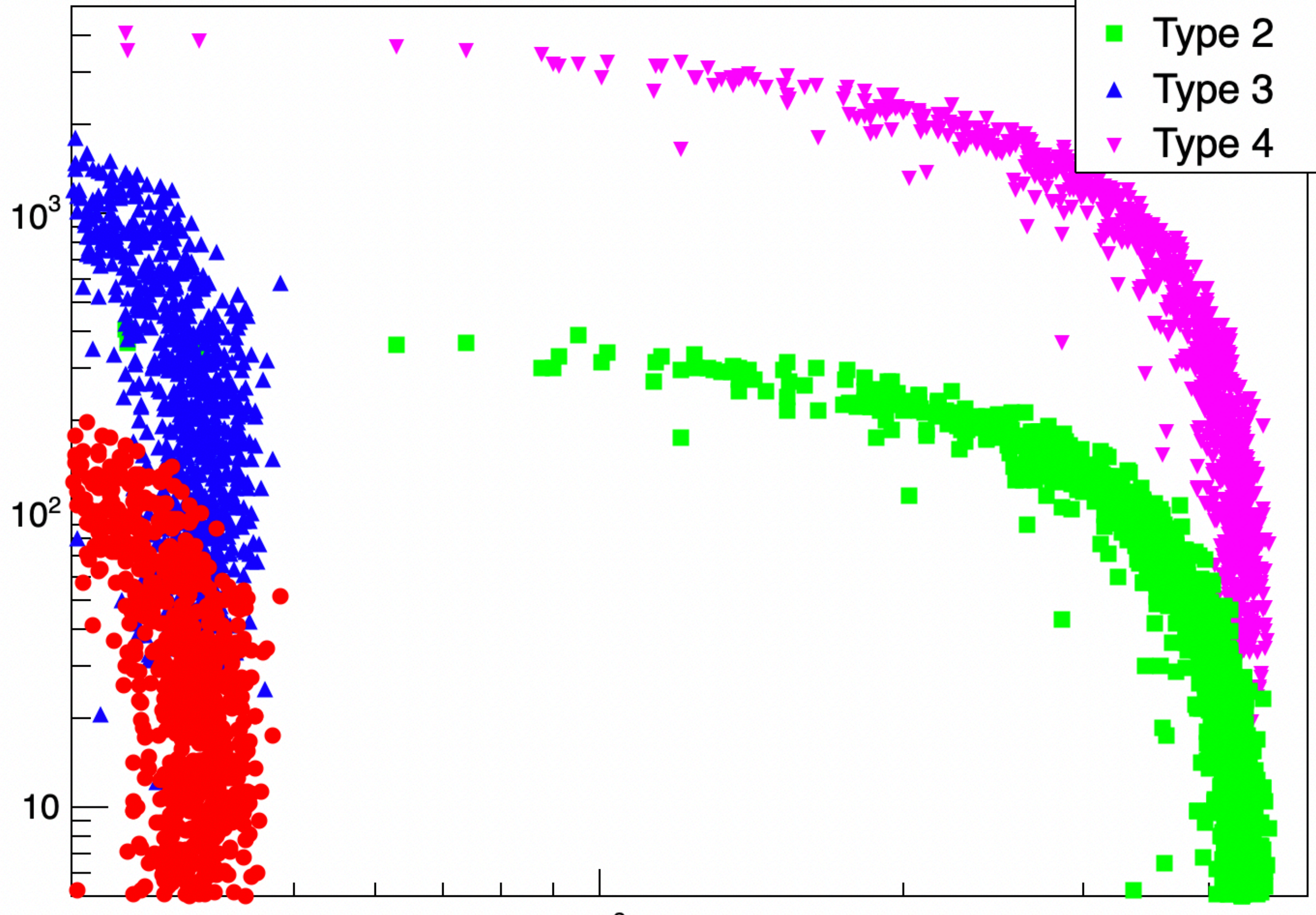

fiberEdep2

fEdepAbsorber2

10^3

fiberEdep1
fEdepAbsorber1

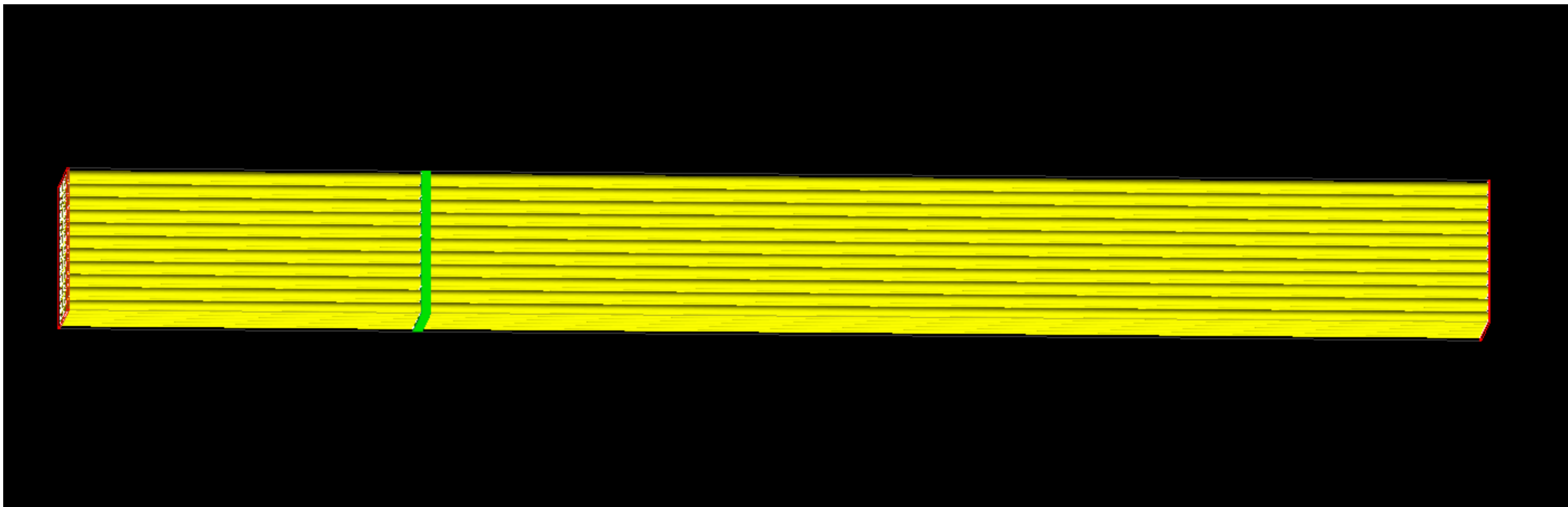
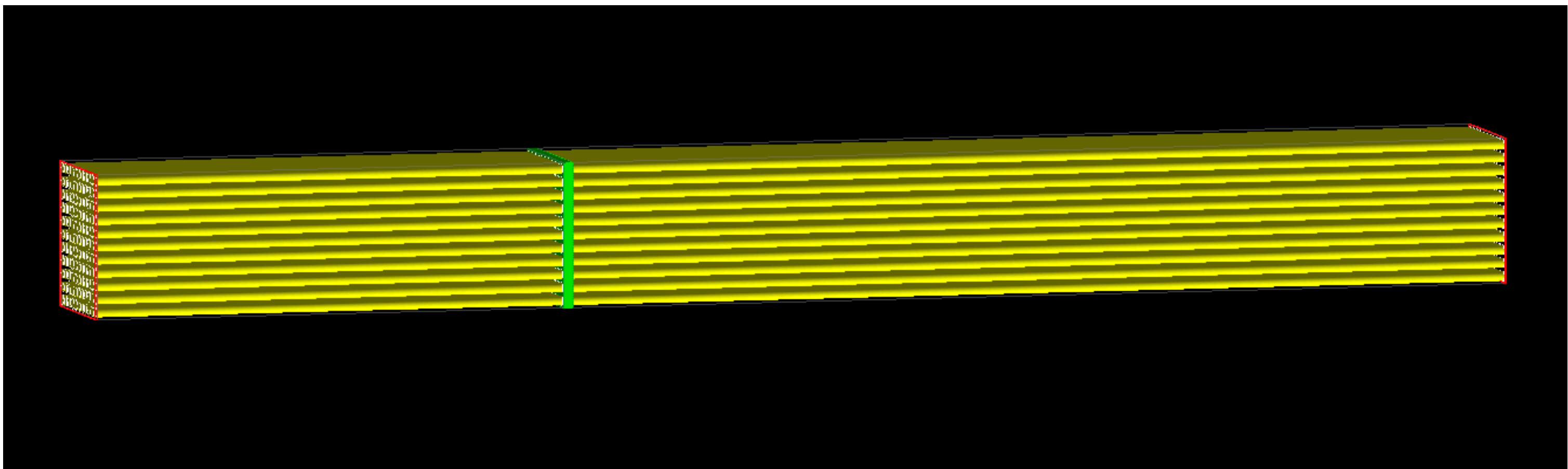

Mirror SpaCal - middle - e - 10GeV

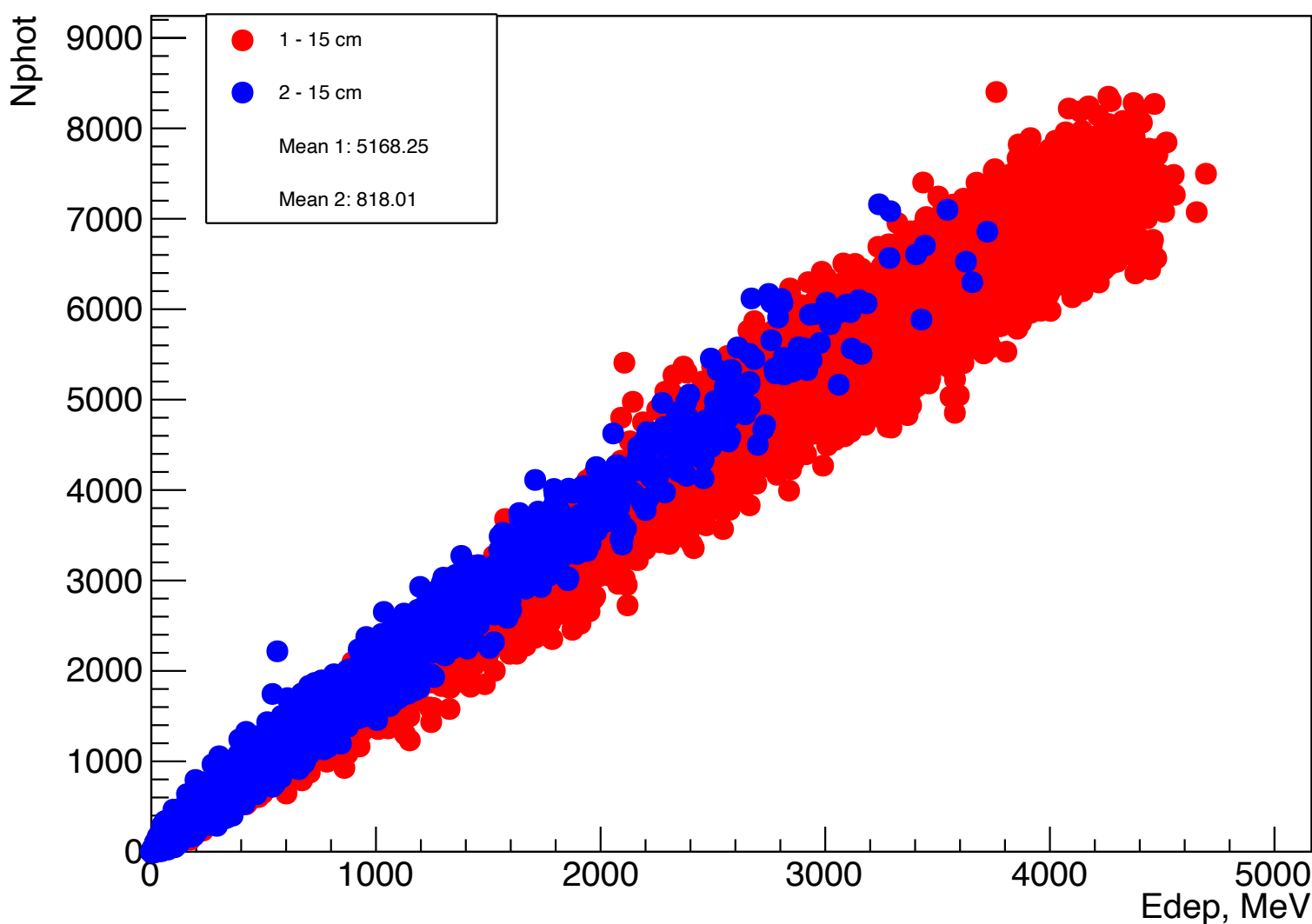

Mirror SpaCal - third - e - 10GeV

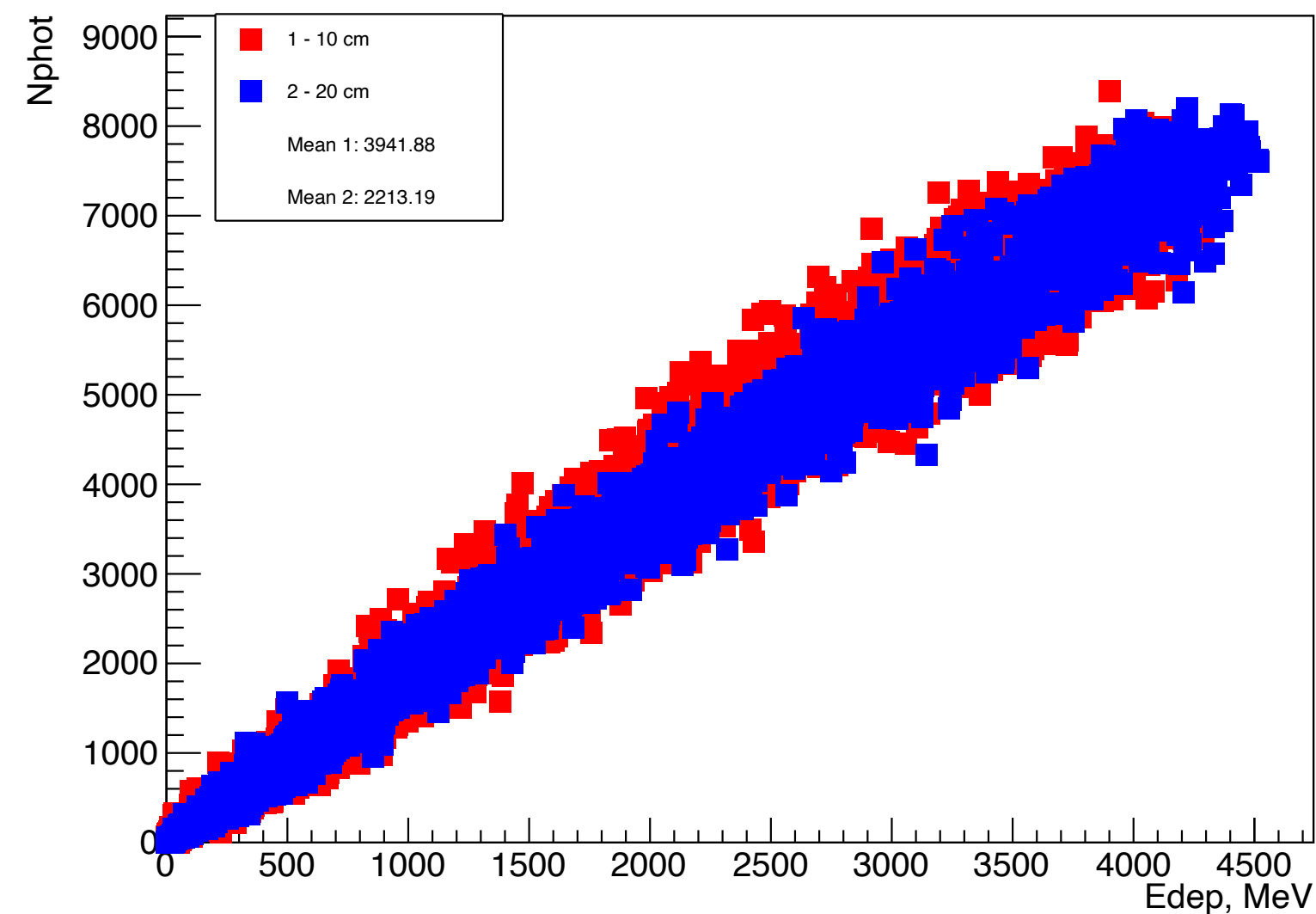

Mirror SpaCal - fourth - e - 10GeV

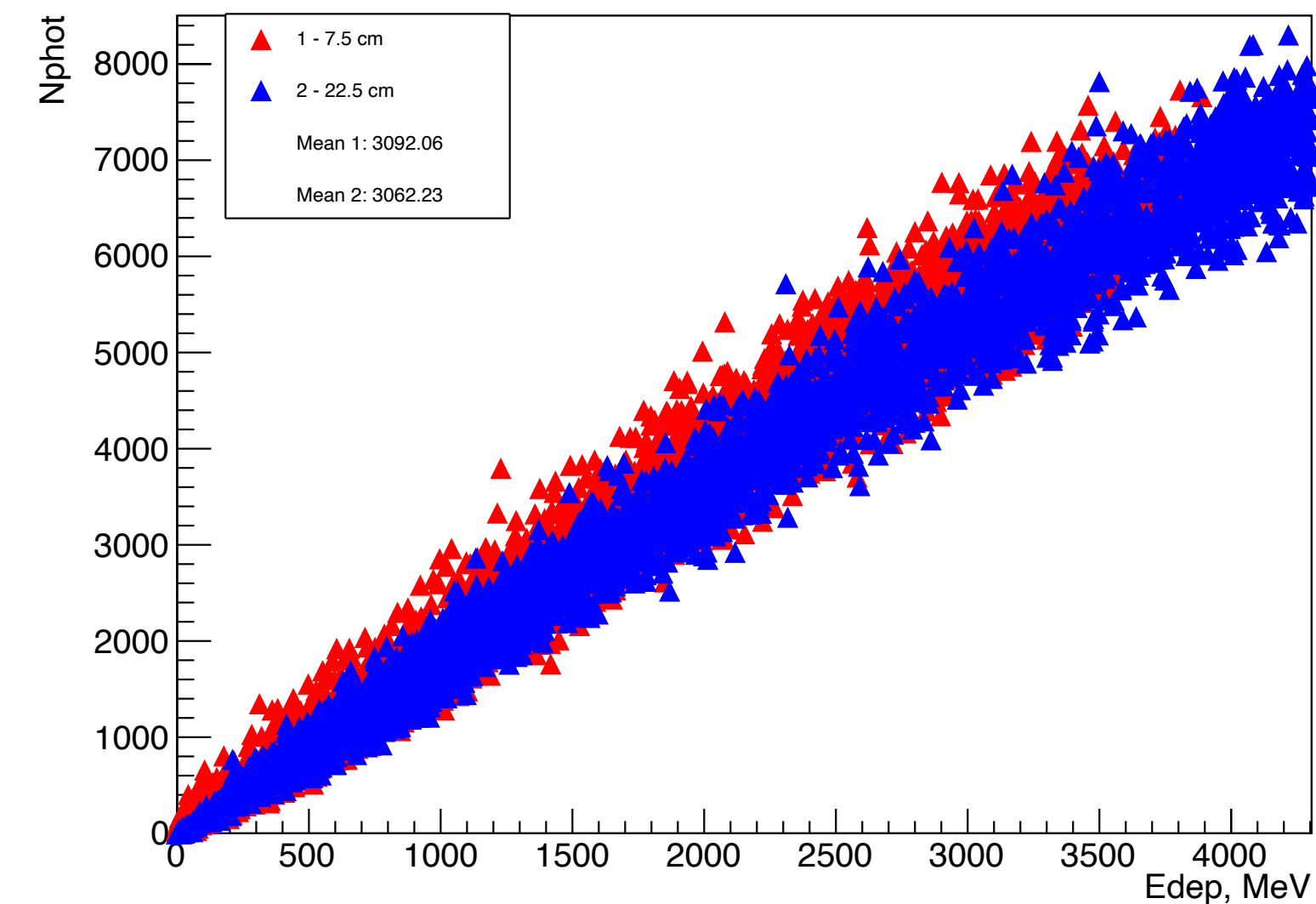

Mirror SpaCal - middle - pi - 10GeV

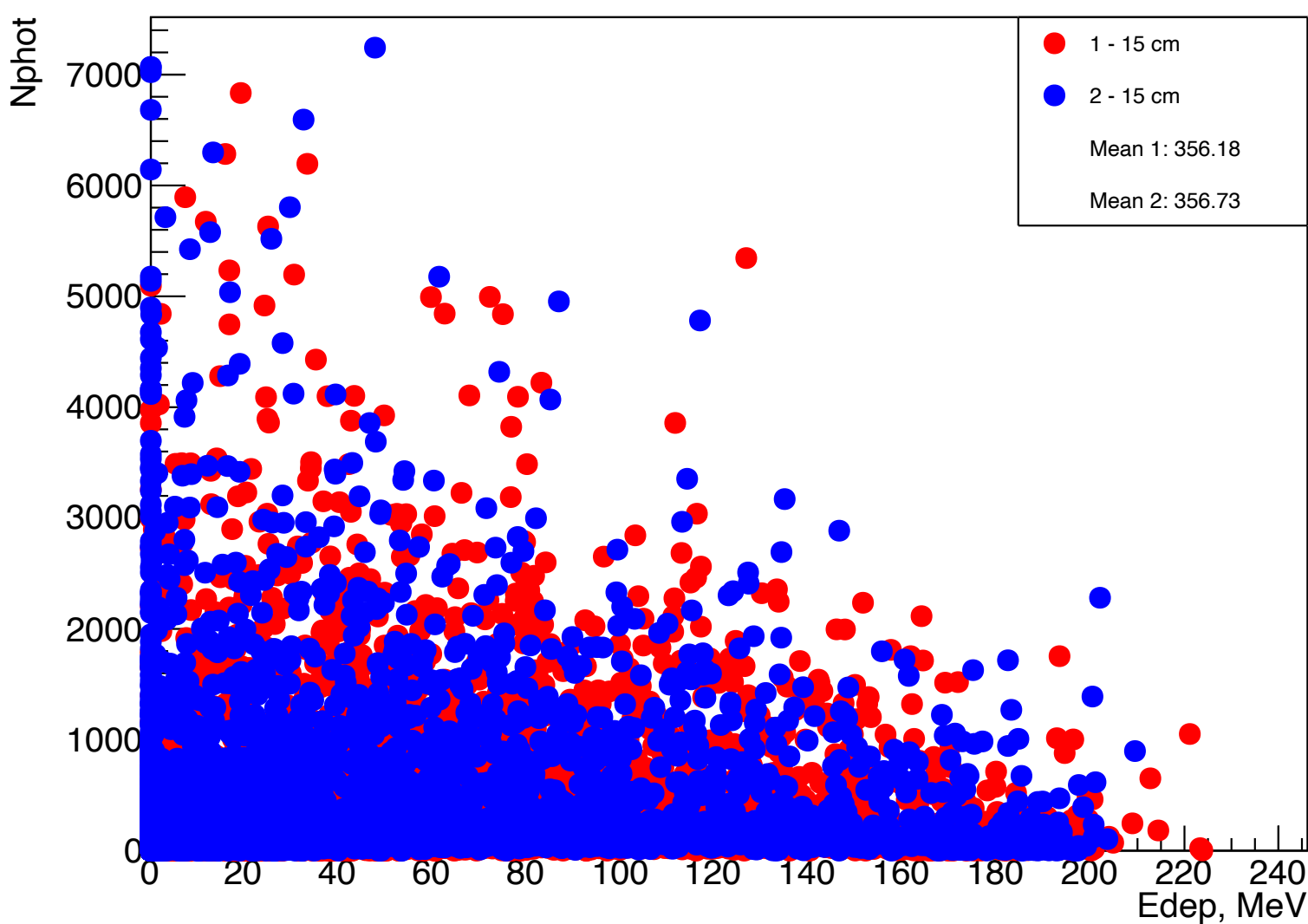

Mirror SpaCal - third - pi - 10GeV

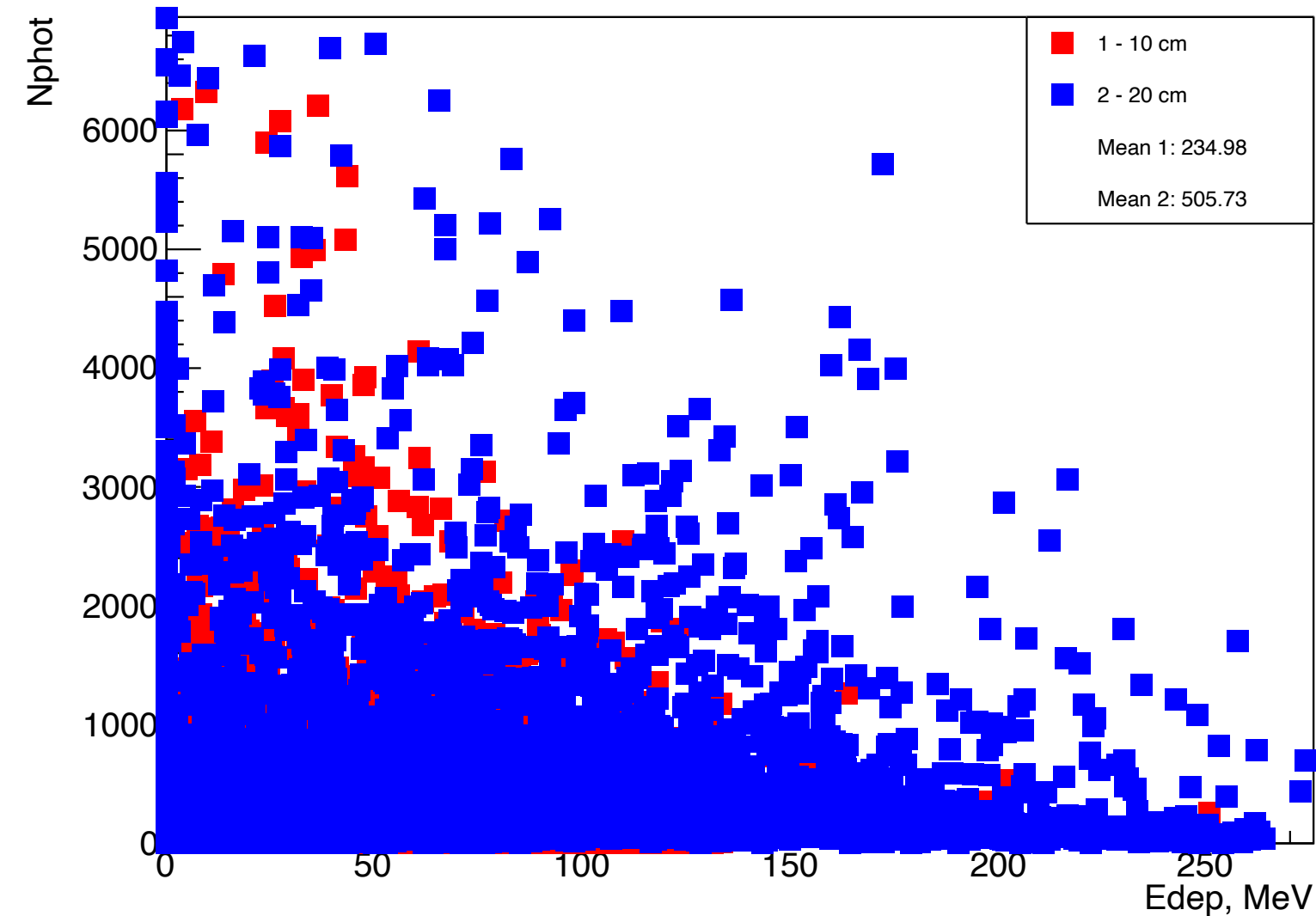

Mirror SpaCal - fourth - pi - 10GeV

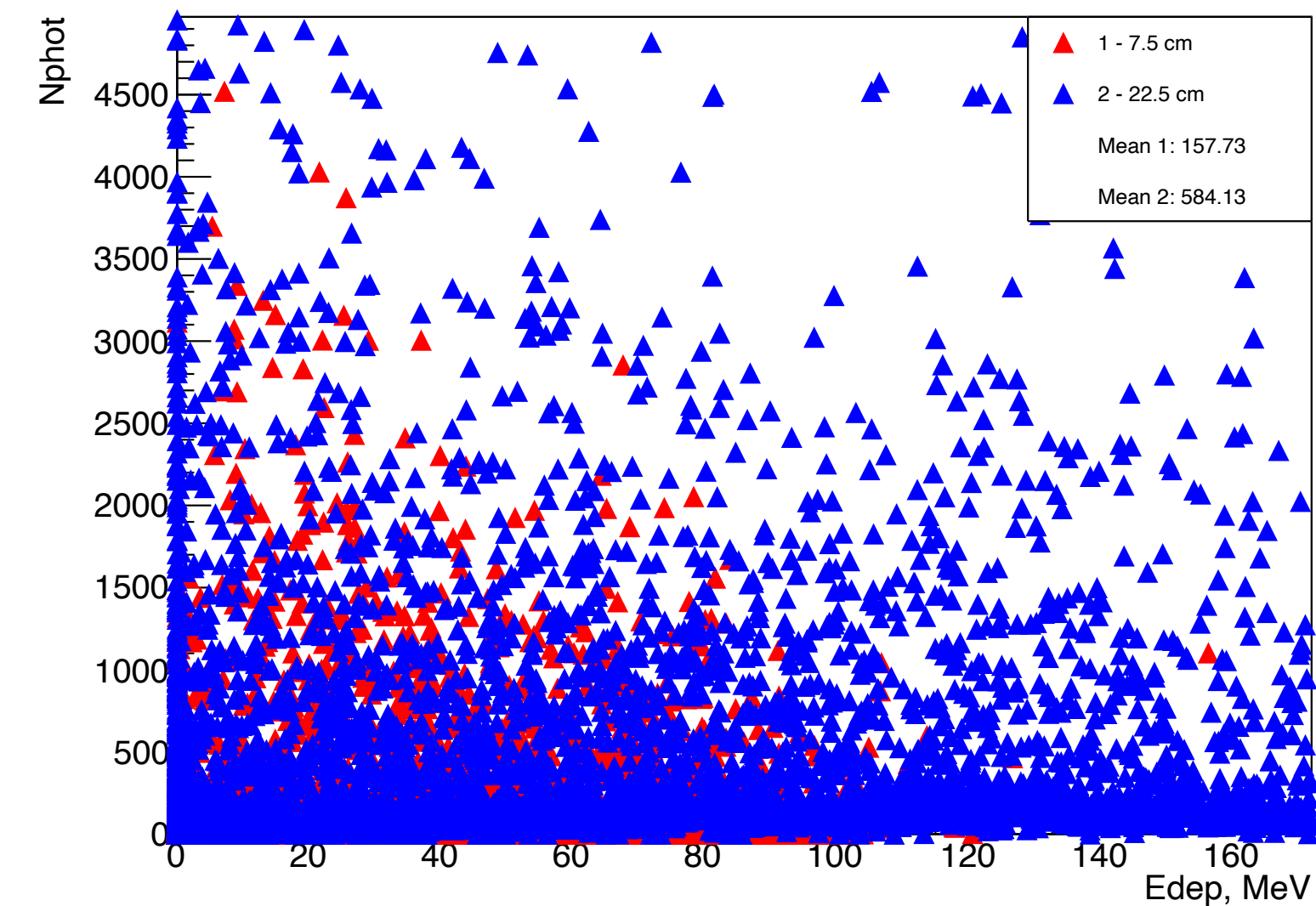

Mirror SpaCal - middle - gamma - 10GeV

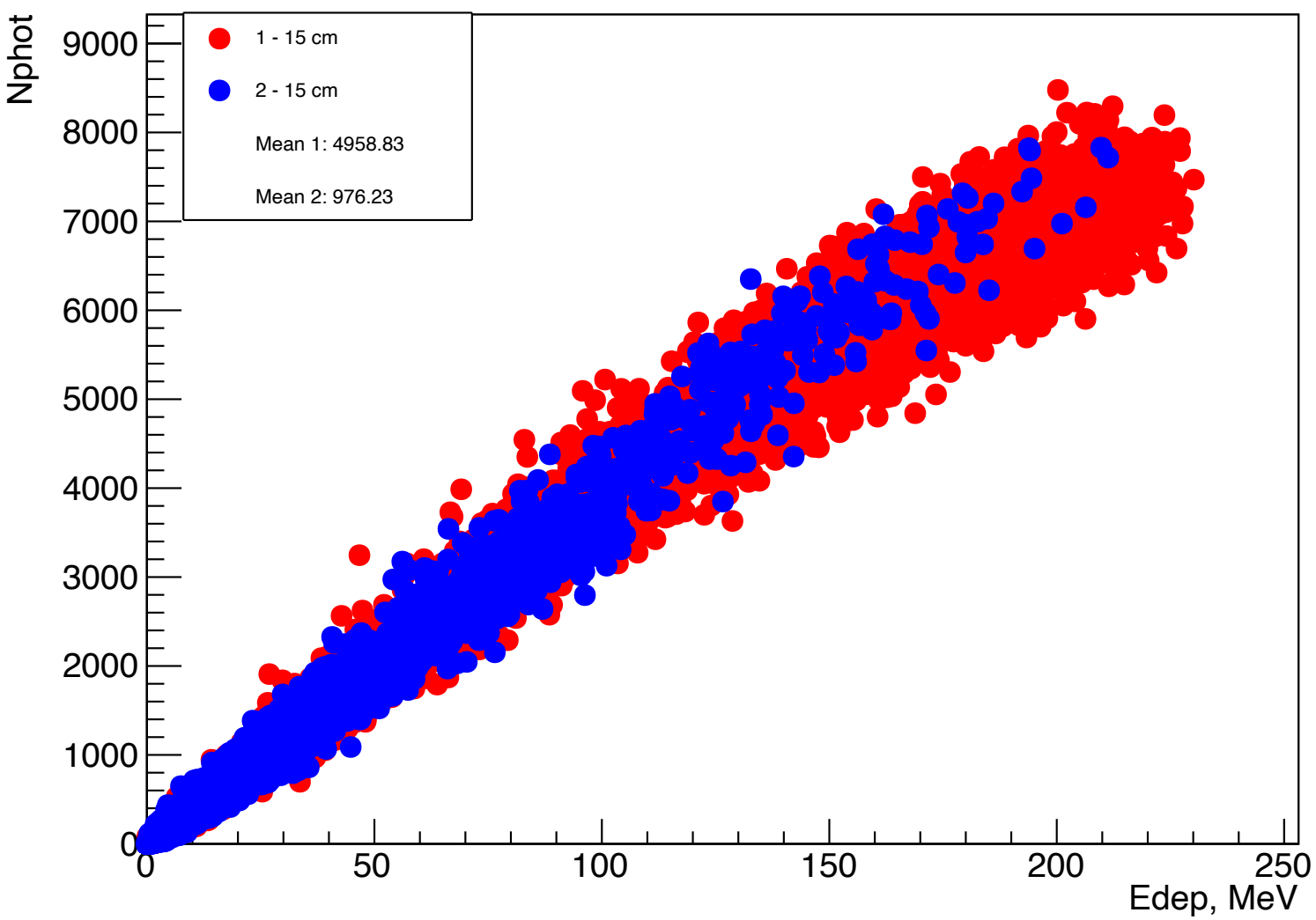

Mirror SpaCal - third - gamma - 10GeV

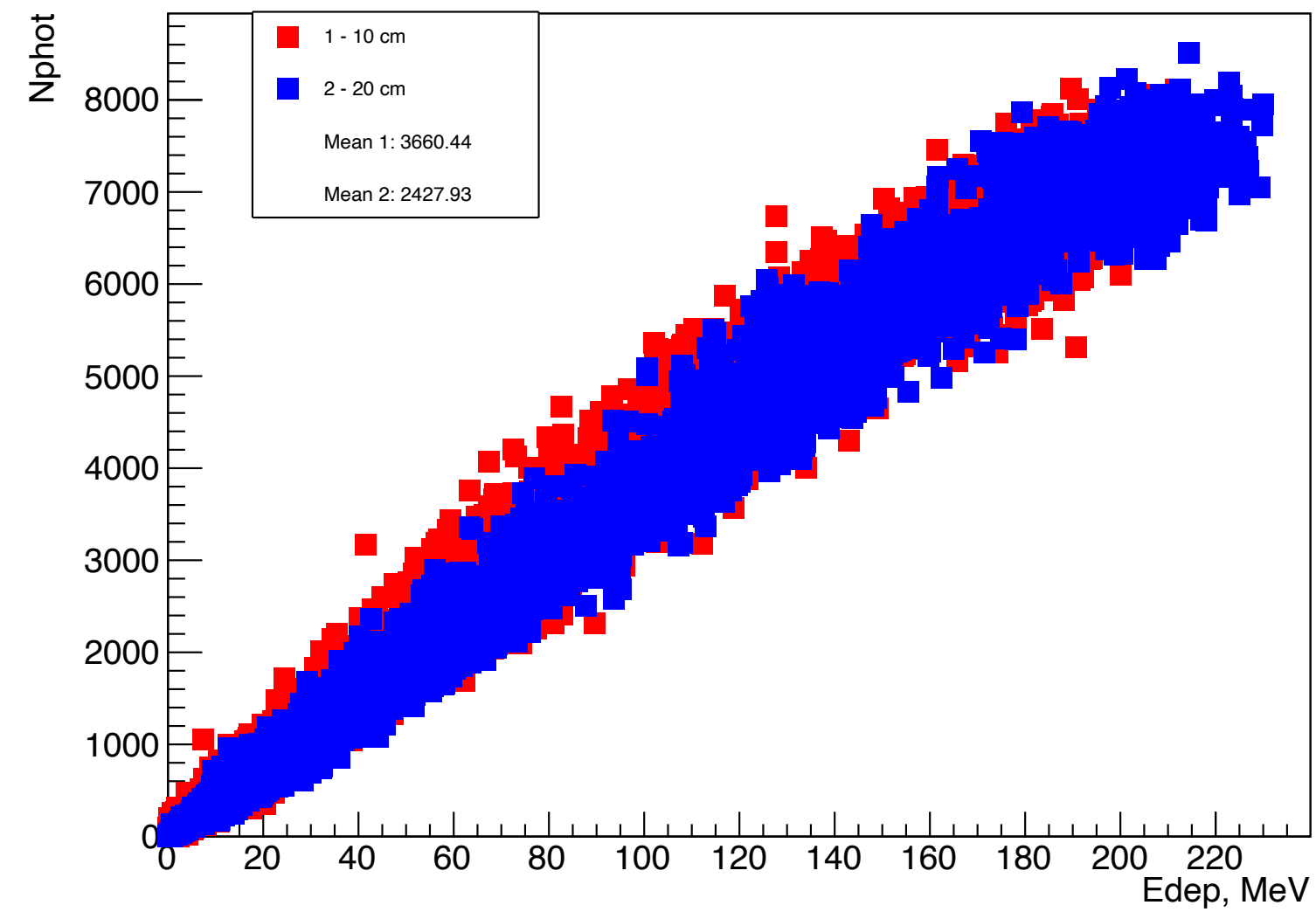

Mirror SpaCal - fourth - gamma - 10GeV

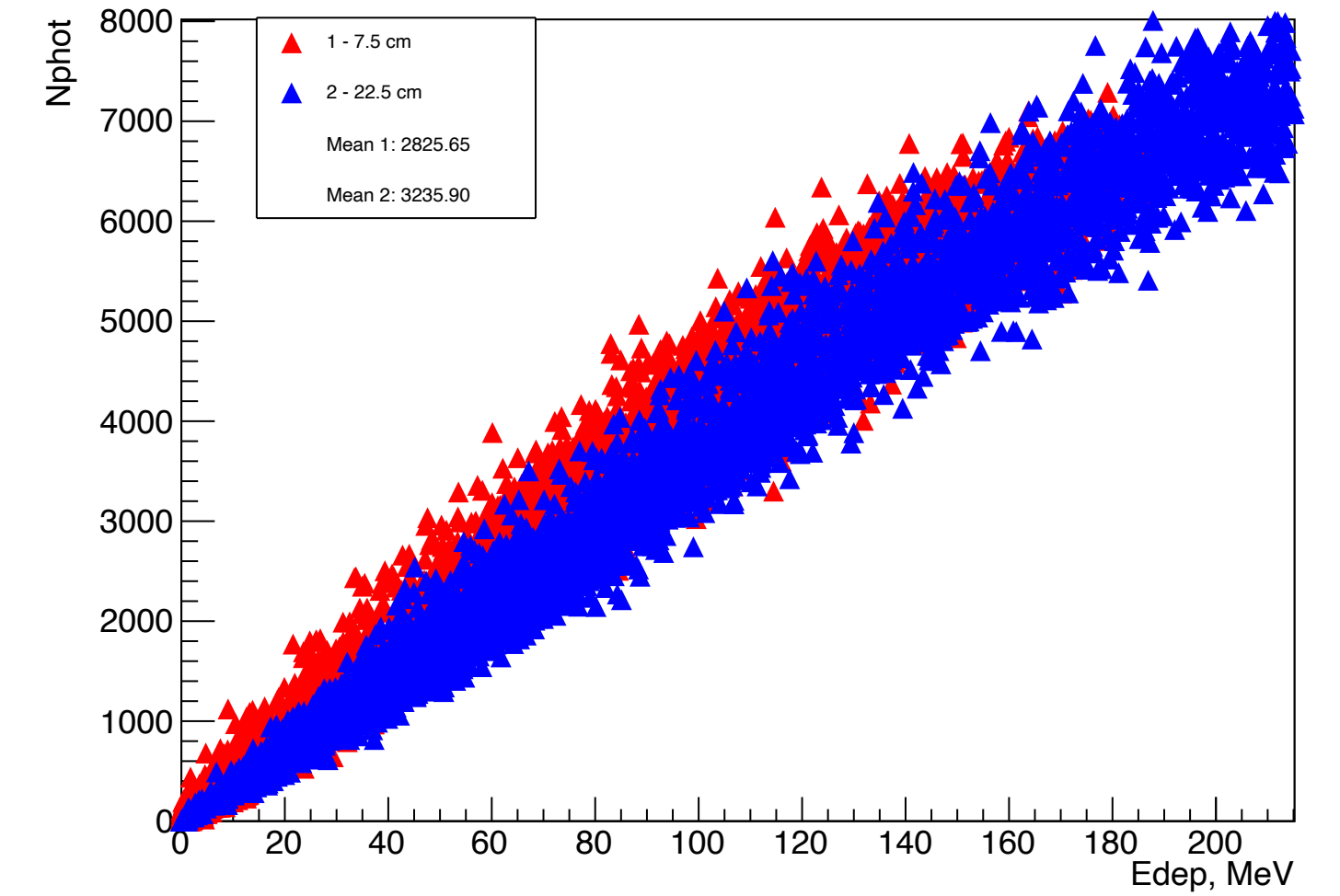

Mirror SpaCal - middle - 10GeV

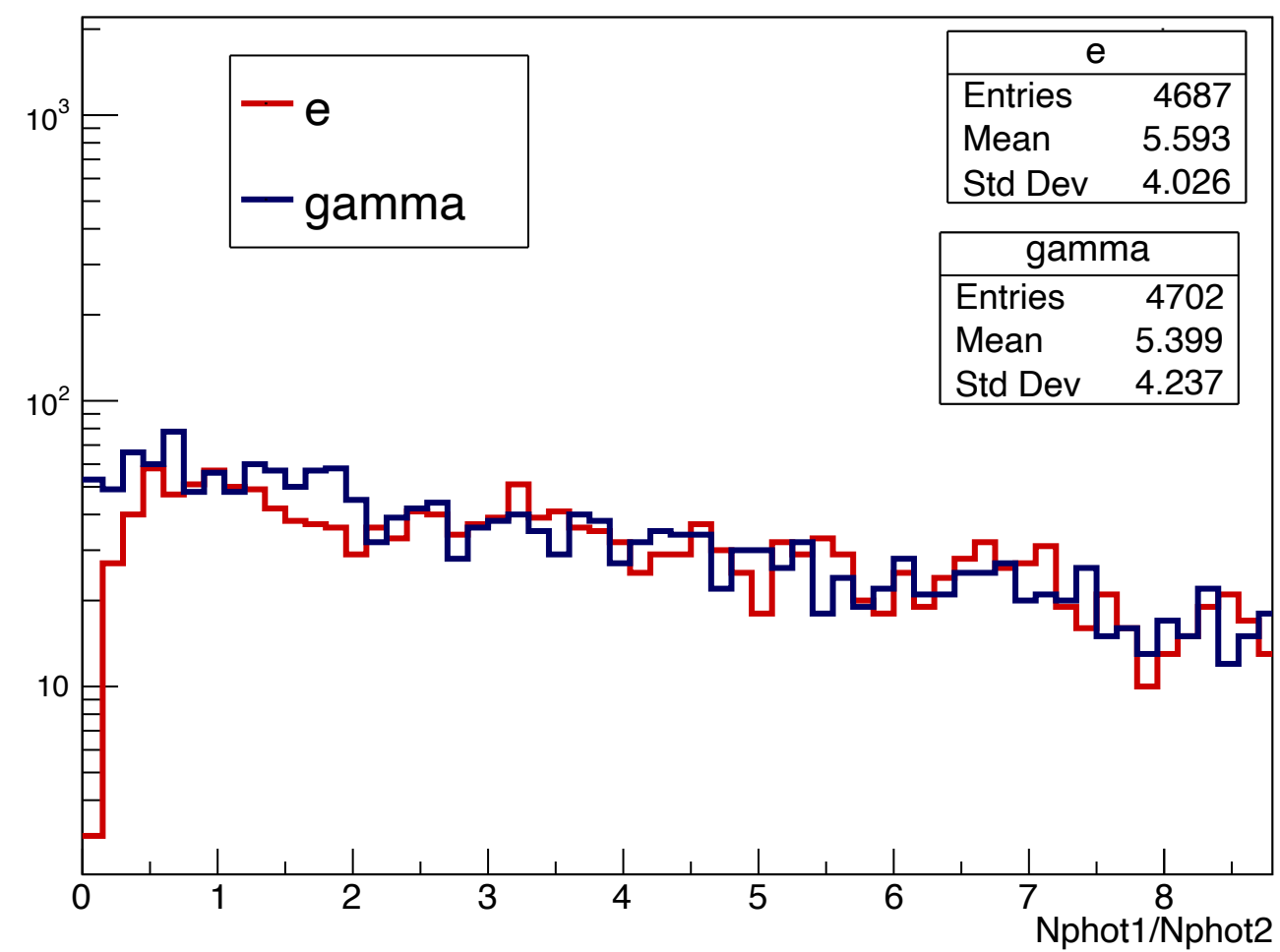

Mirror SpaCal - third - 10GeV

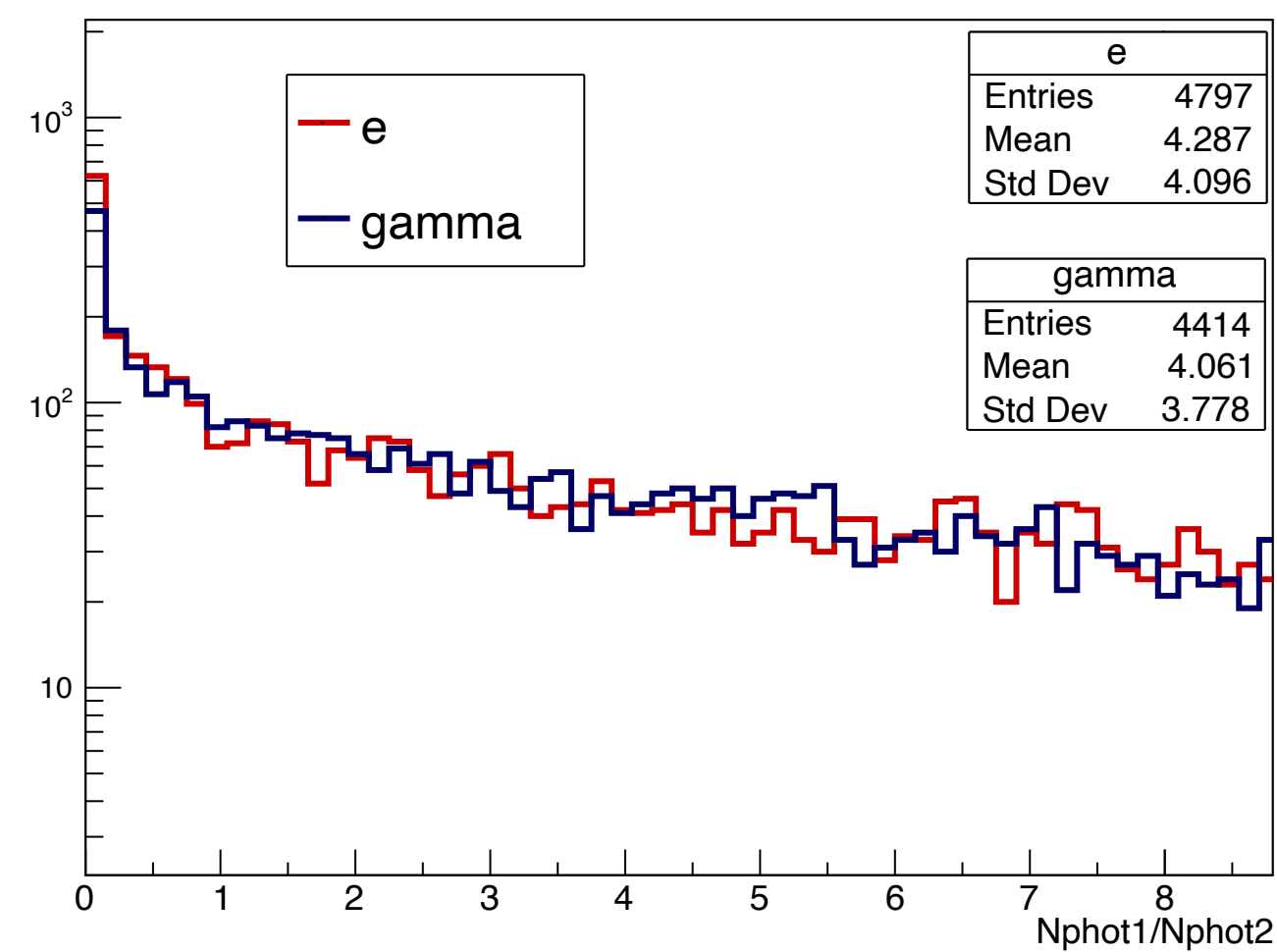

Mirror SpaCal - fourth - 10GeV

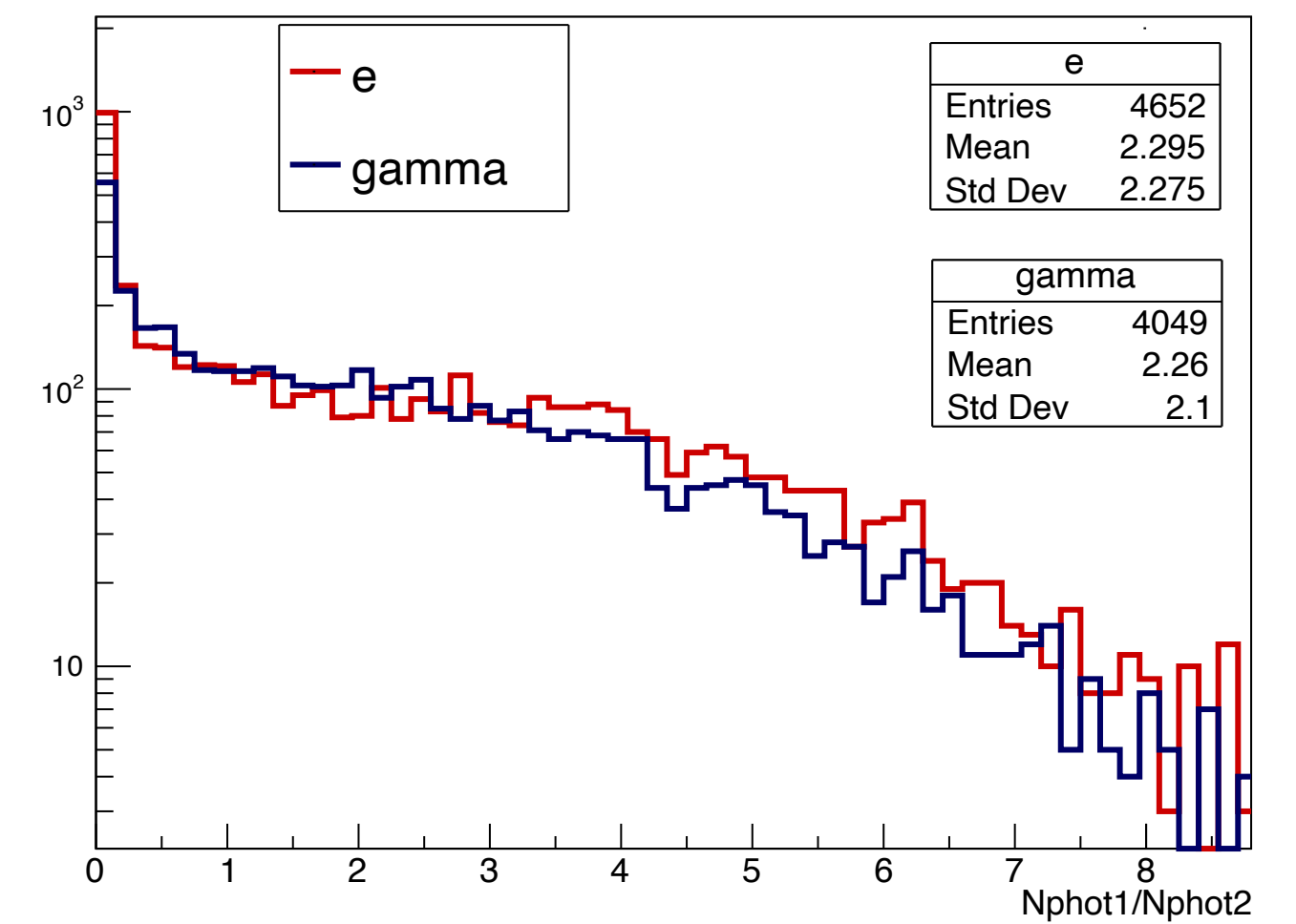

Mirror SpaCal - middle - e - 10GeV

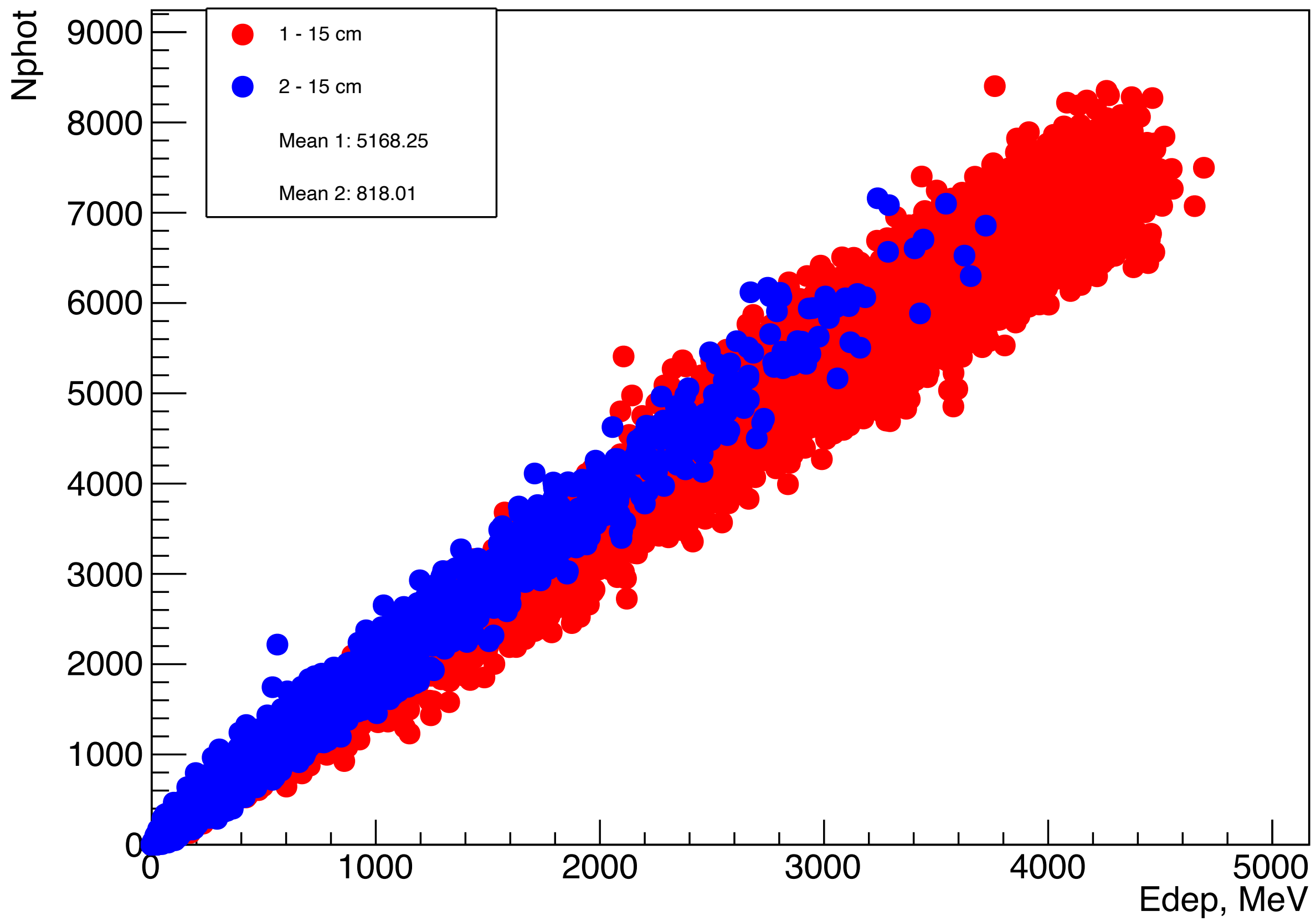

Mirror SpaCal - middle - pi - 10GeV

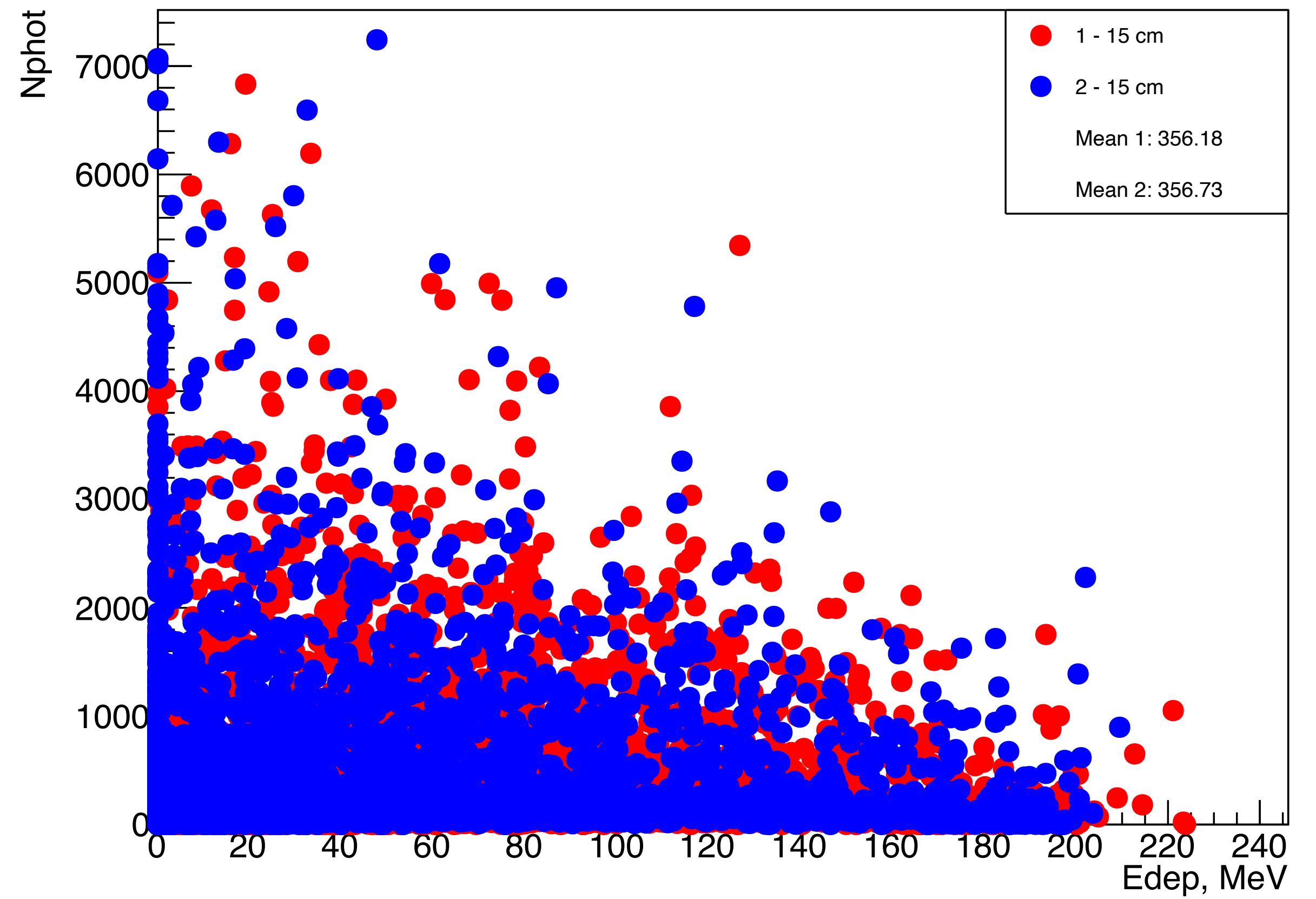

Mirror SpaCal - third - e - 10GeV

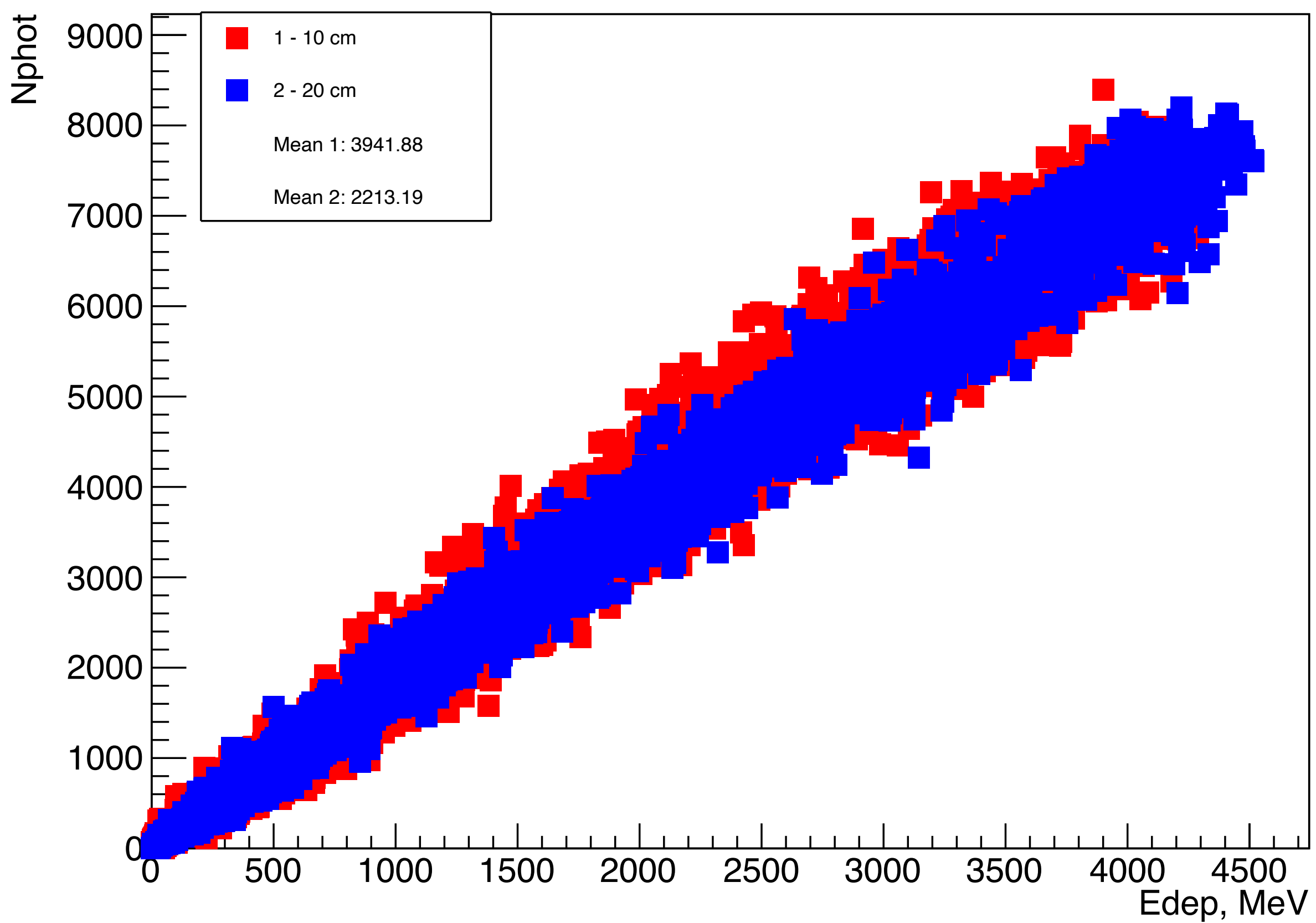

Mirror SpaCal - third - pi - 10GeV

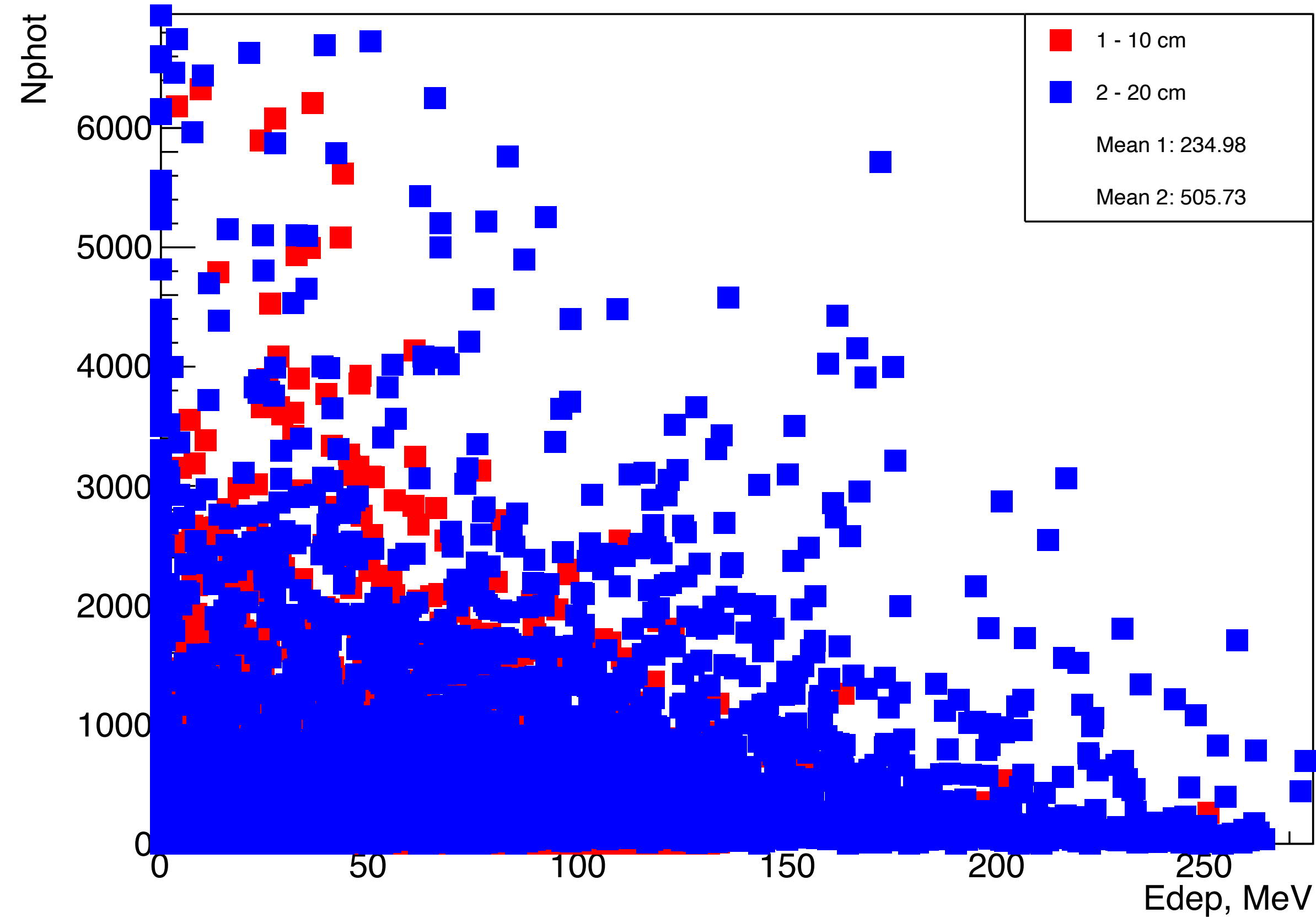

Mirror SpaCal - fourth - e - 10GeV

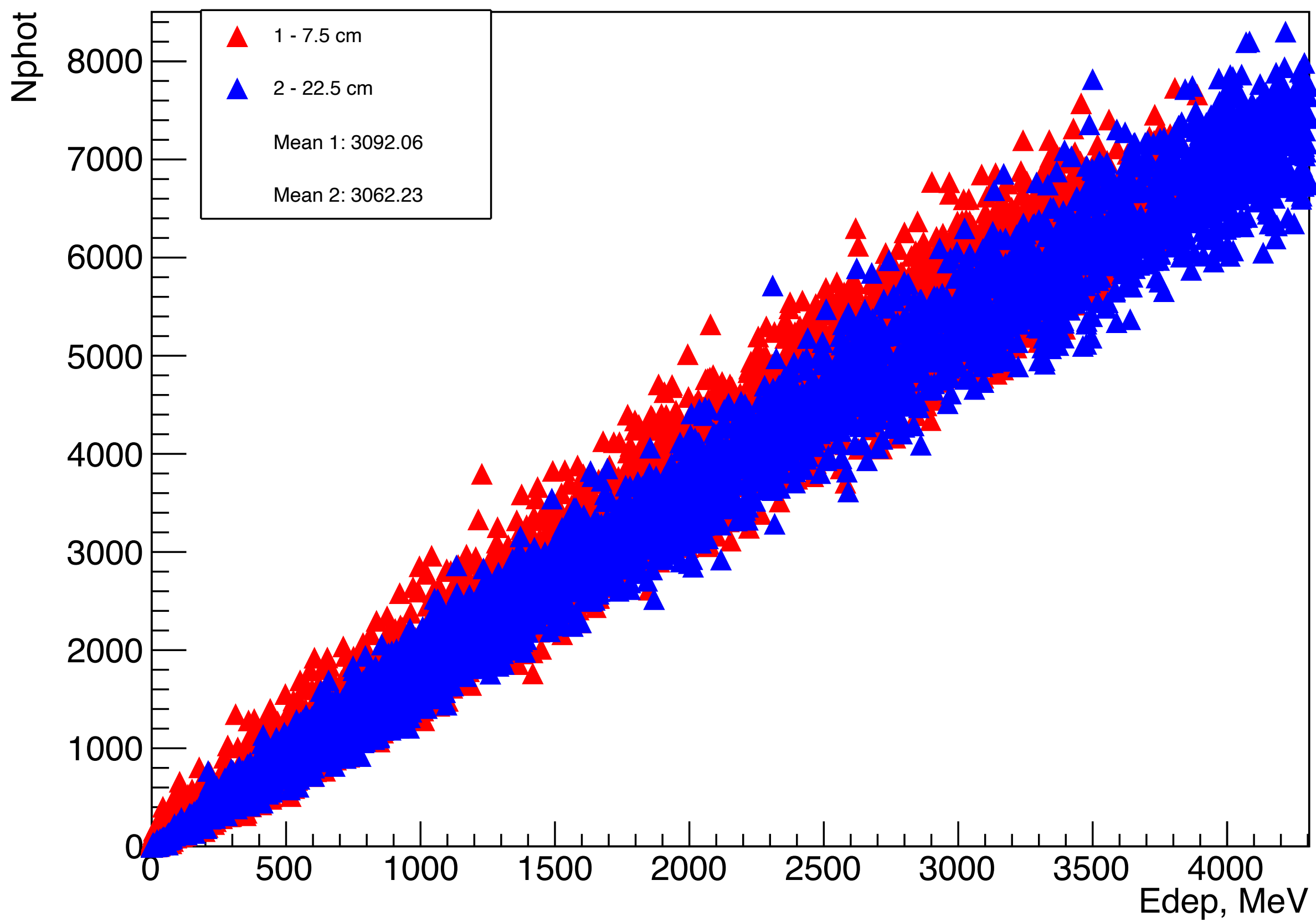

Mirror SpaCal - fourth - pi - 10GeV

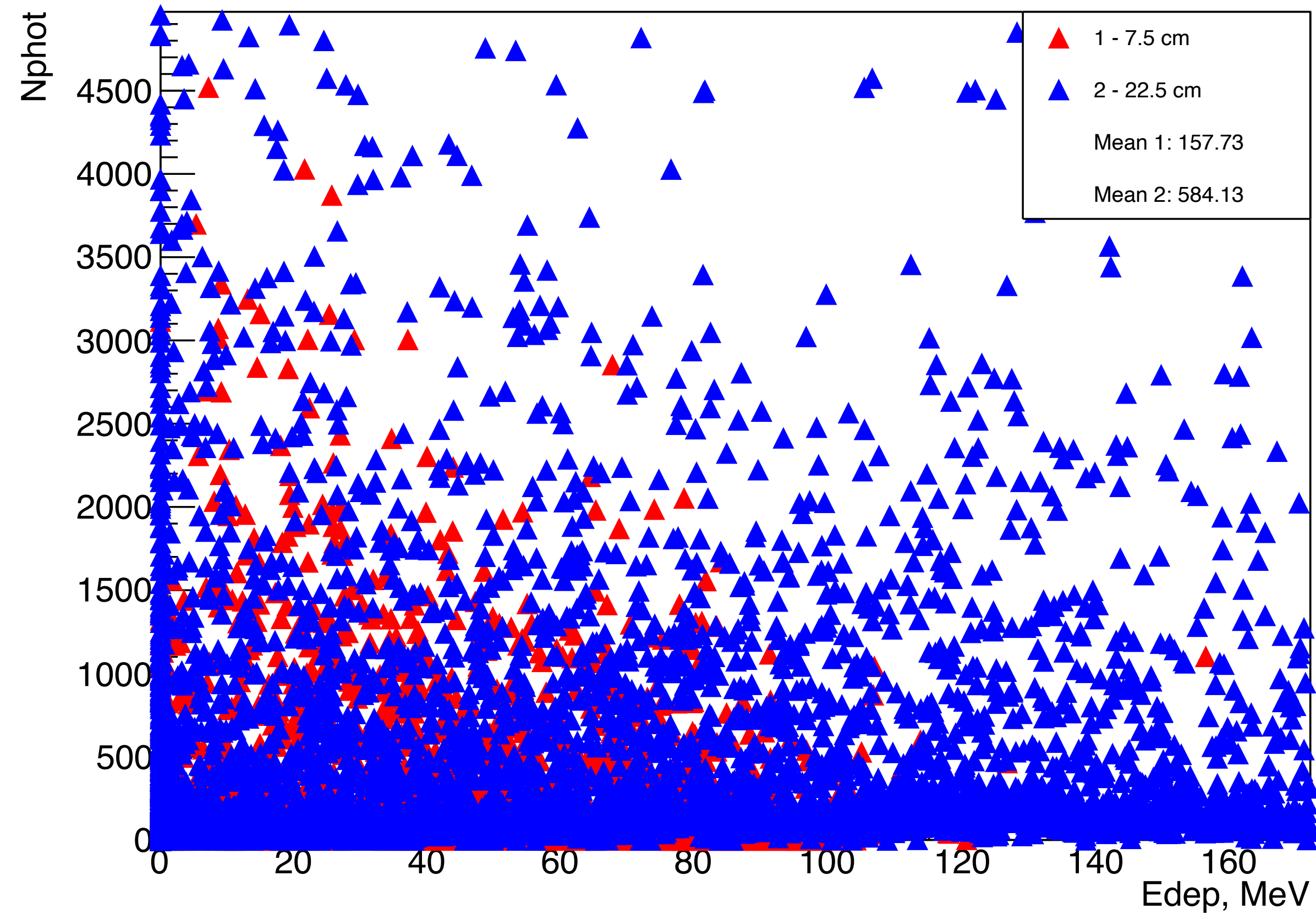

Mirror SpaCal - middle - e - 10GeV

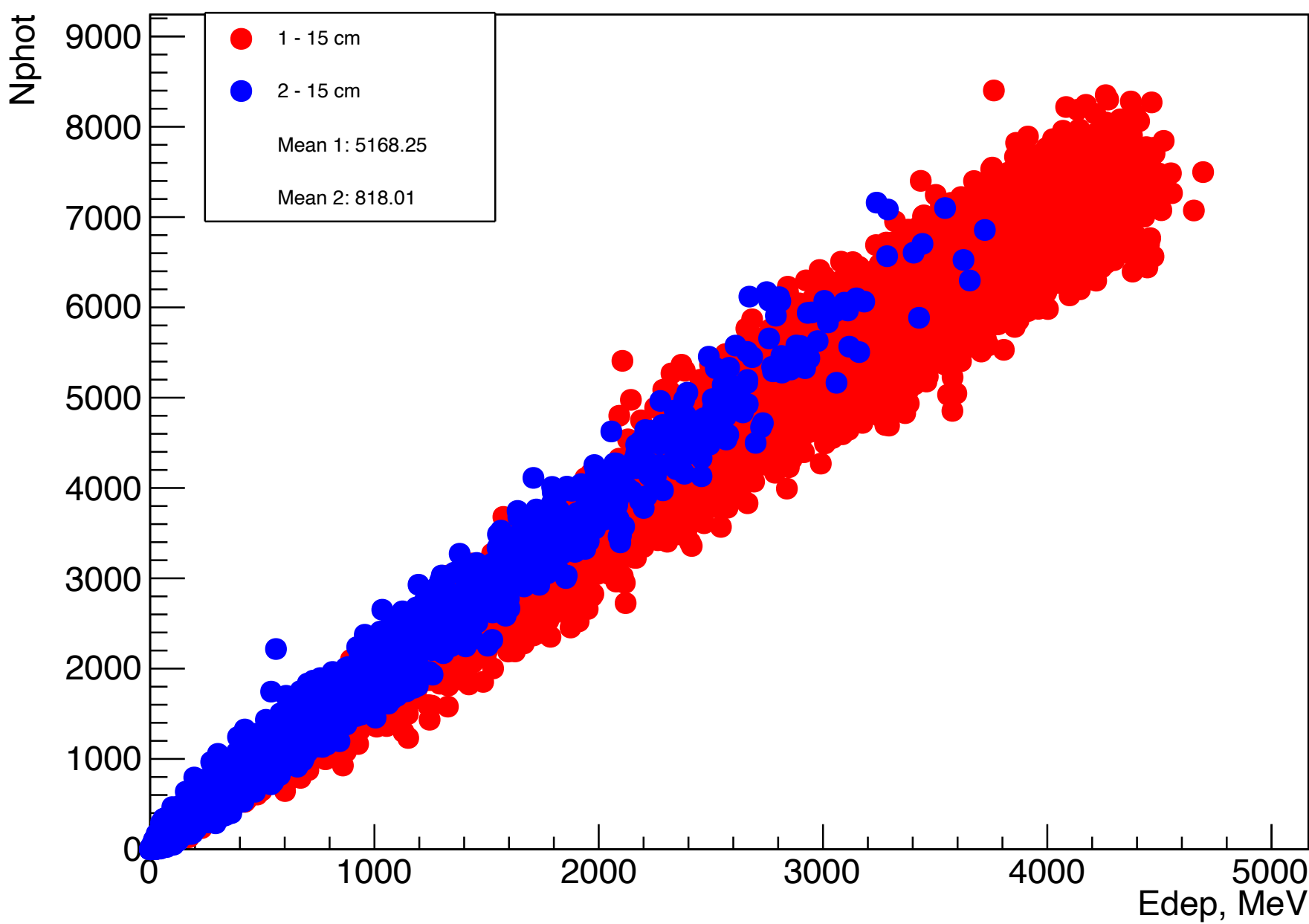

Mirror SpaCal - middle - pi - 10GeV

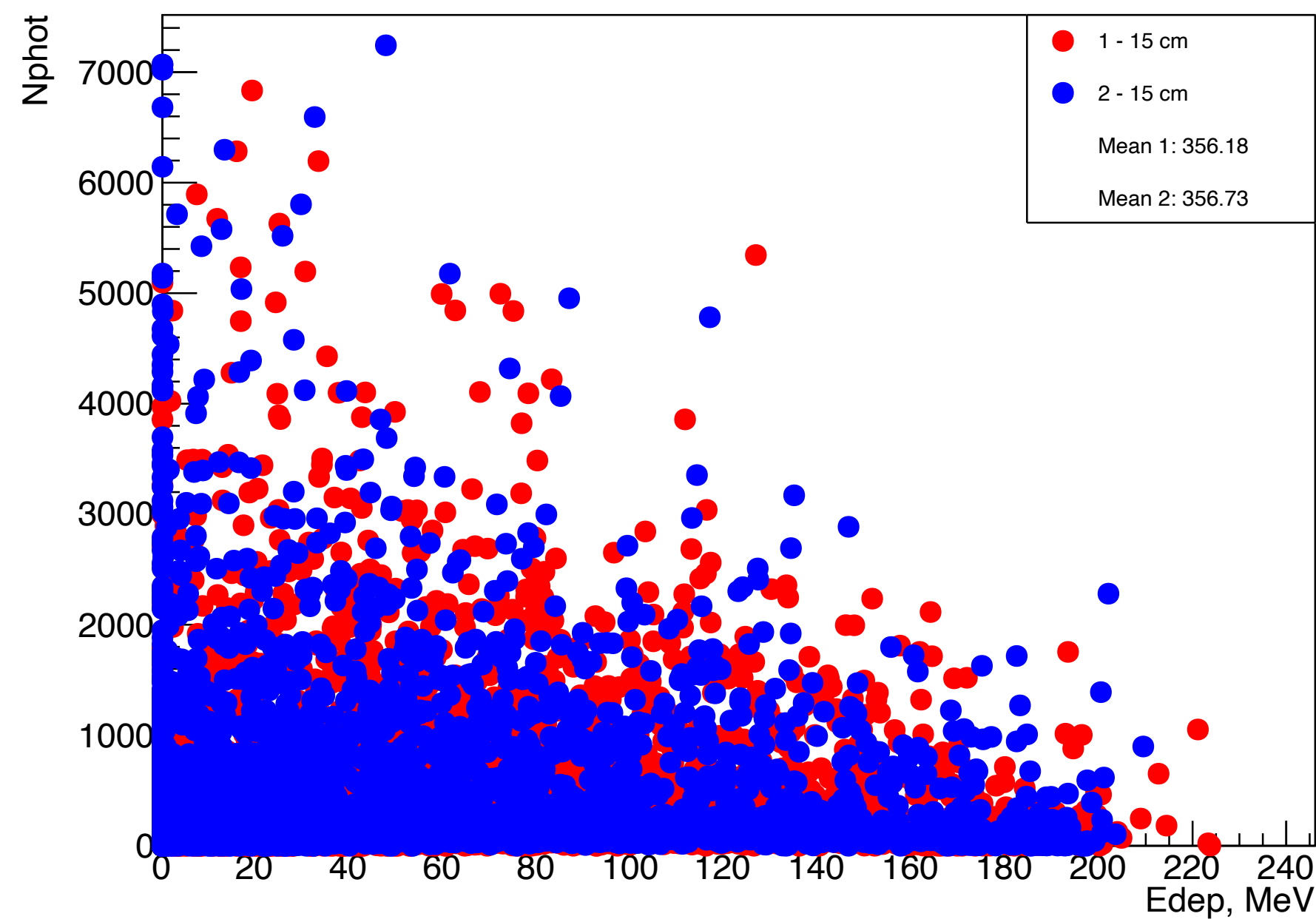

Распознавание электронов и пионов с помощью модуля SpaCal с зеркальным слоем.

Расположение зеркала: середина — 15см/15см.

Было брошено 5000 первичных электронов и пионов с энергией 10 ГэВ.

Точка входа частицы разыграна равномерно от -1,5 см до 1,5 см в плоскости ху.

Красные точки: энерговыведение и оптические фотоны до зеркала;

Синие точки: энерговыведение и оптические фотоны после зеркала.

Mirror SpaCal - middle - 10GeV

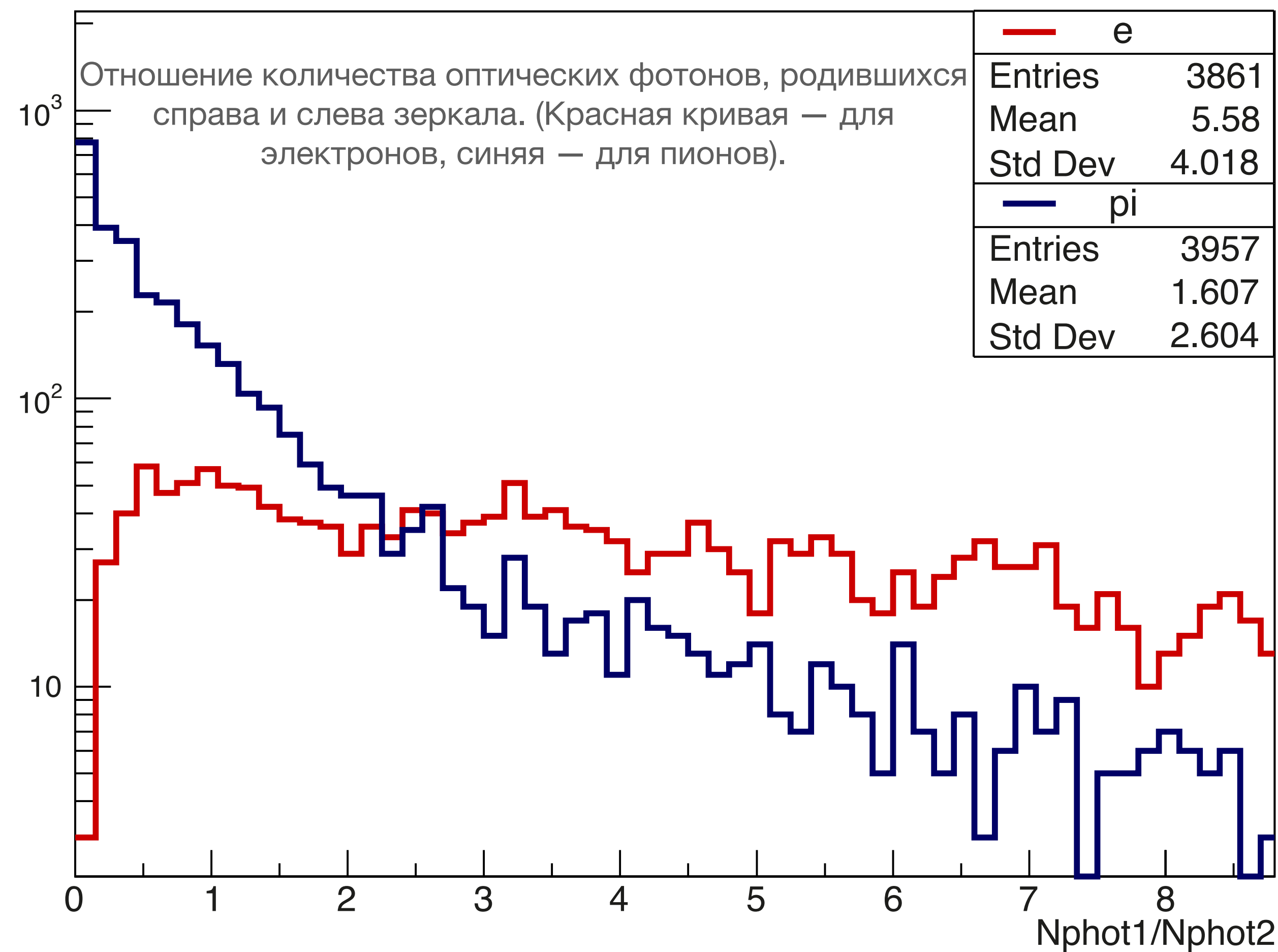

Mirror SpaCal - middle - 10GeV

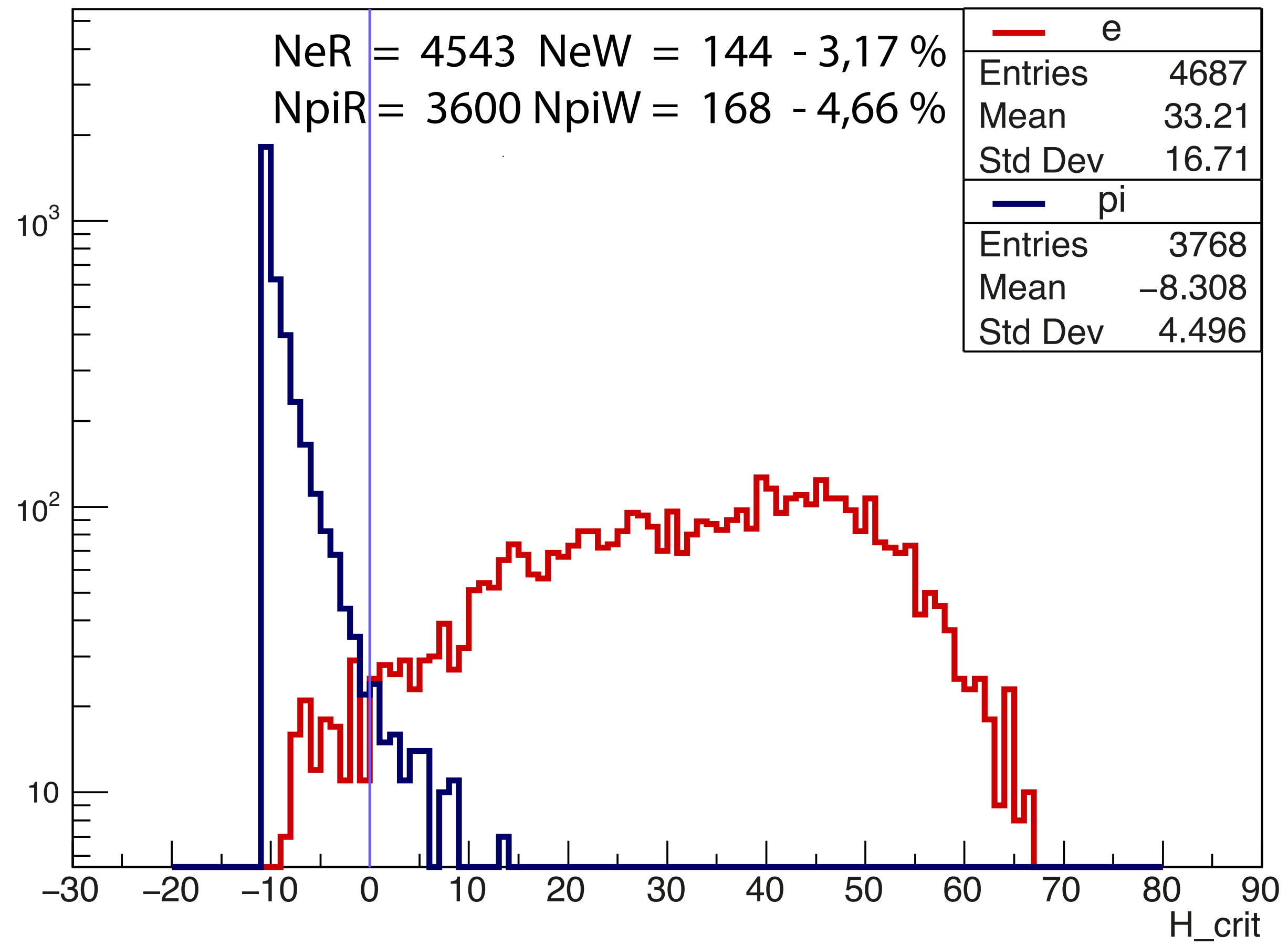

Mirror SpaCal - third - e - 10GeV

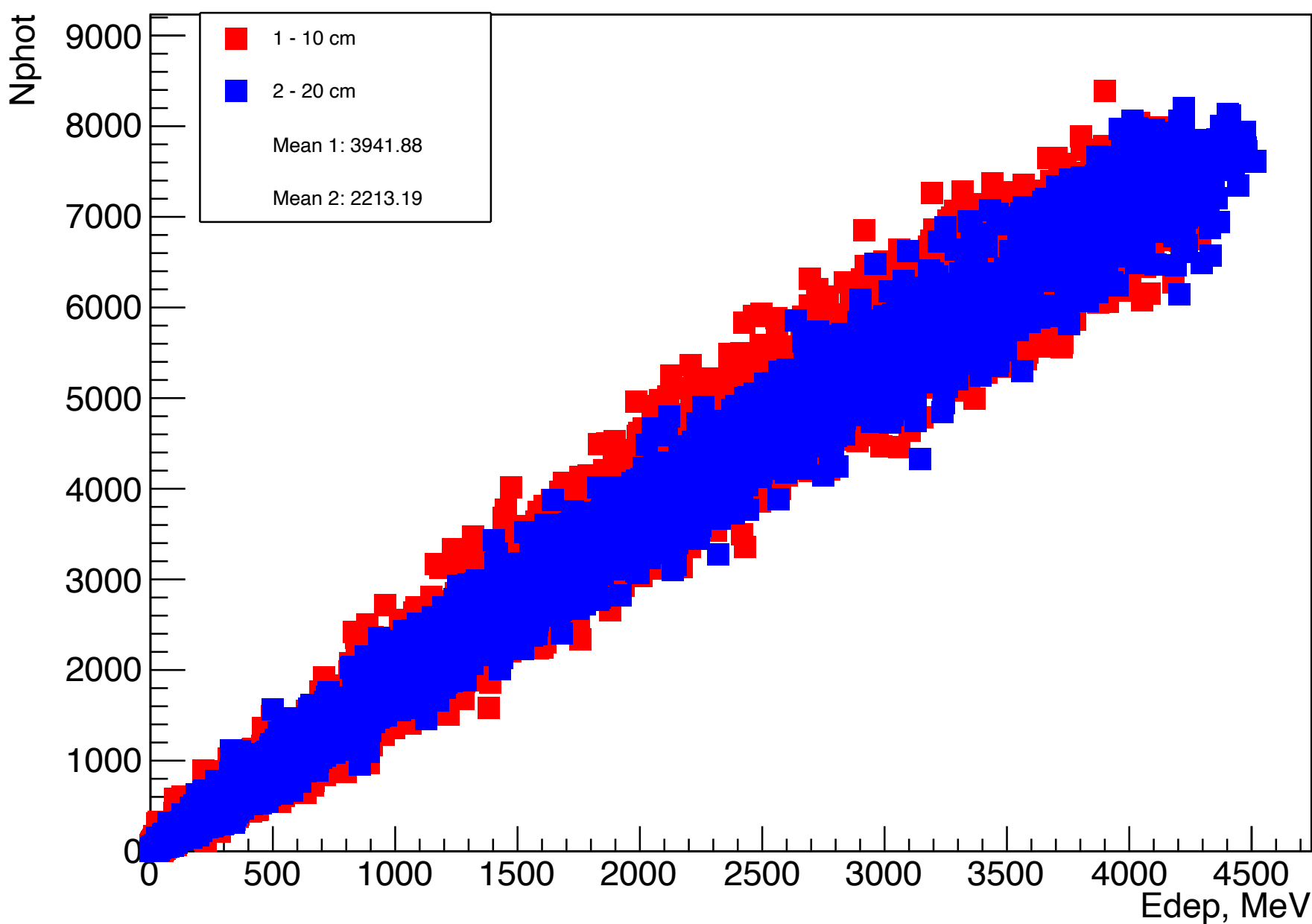

Расположение зеркала: 10см/20см. Было брошено 5000 первичных электронов и пионов с энергией 10 ГэВ. Точка входа частицы разыграна равномерно от -1,5 см до 1,5 см в плоскости ху.
 Красные точки: энергосодержание и оптические фотоны до зеркала;
 Синие точки: энергосодержание и оптические фотоны после зеркала.

Mirror SpaCal - third - 10GeV

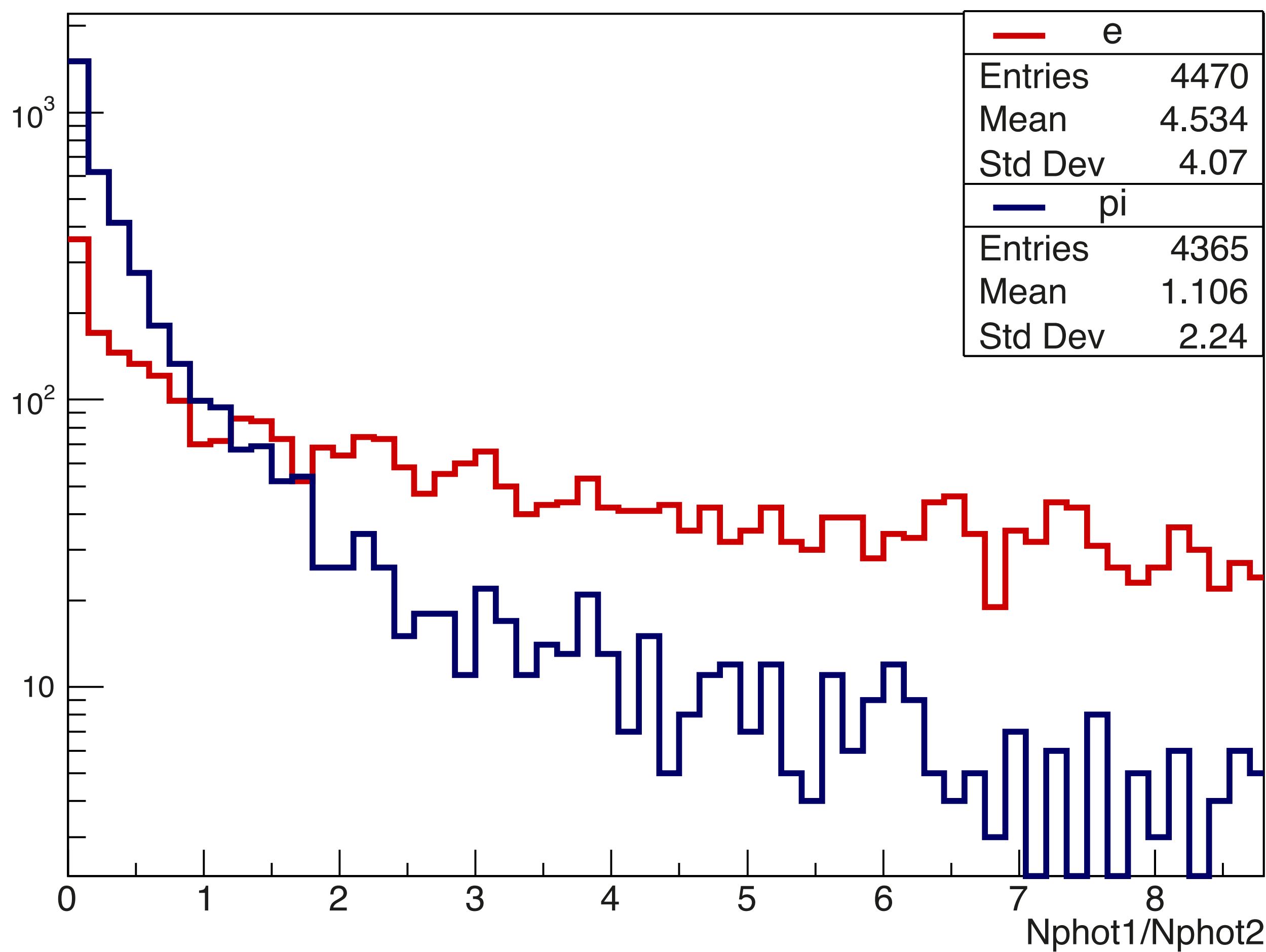

Mirror SpaCal - third - pi - 10GeV

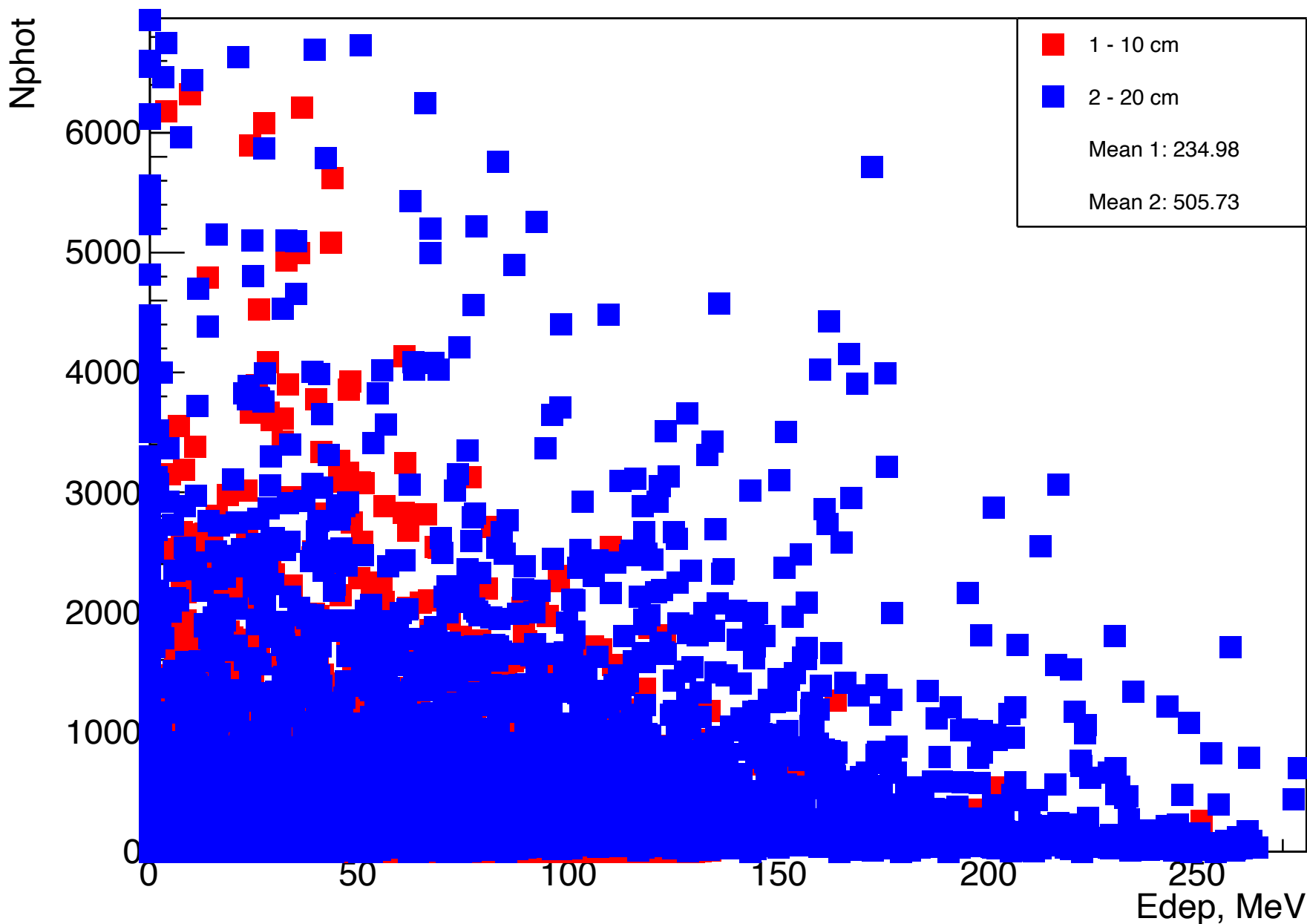

осцирансу
енергии

Mirror SpaCal - third - 10GeV

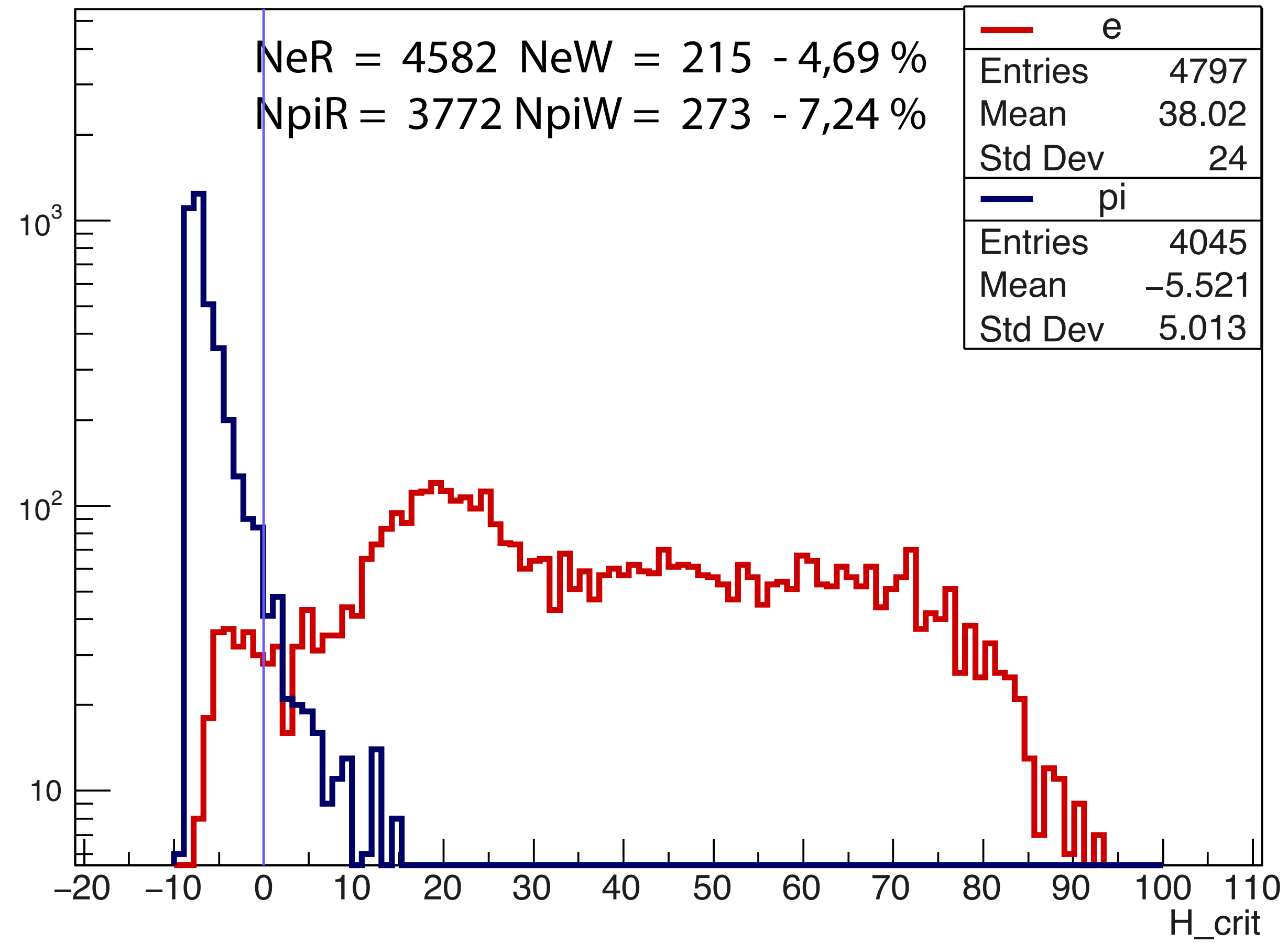

Mirror SpaCal - fourth - e - 10GeV

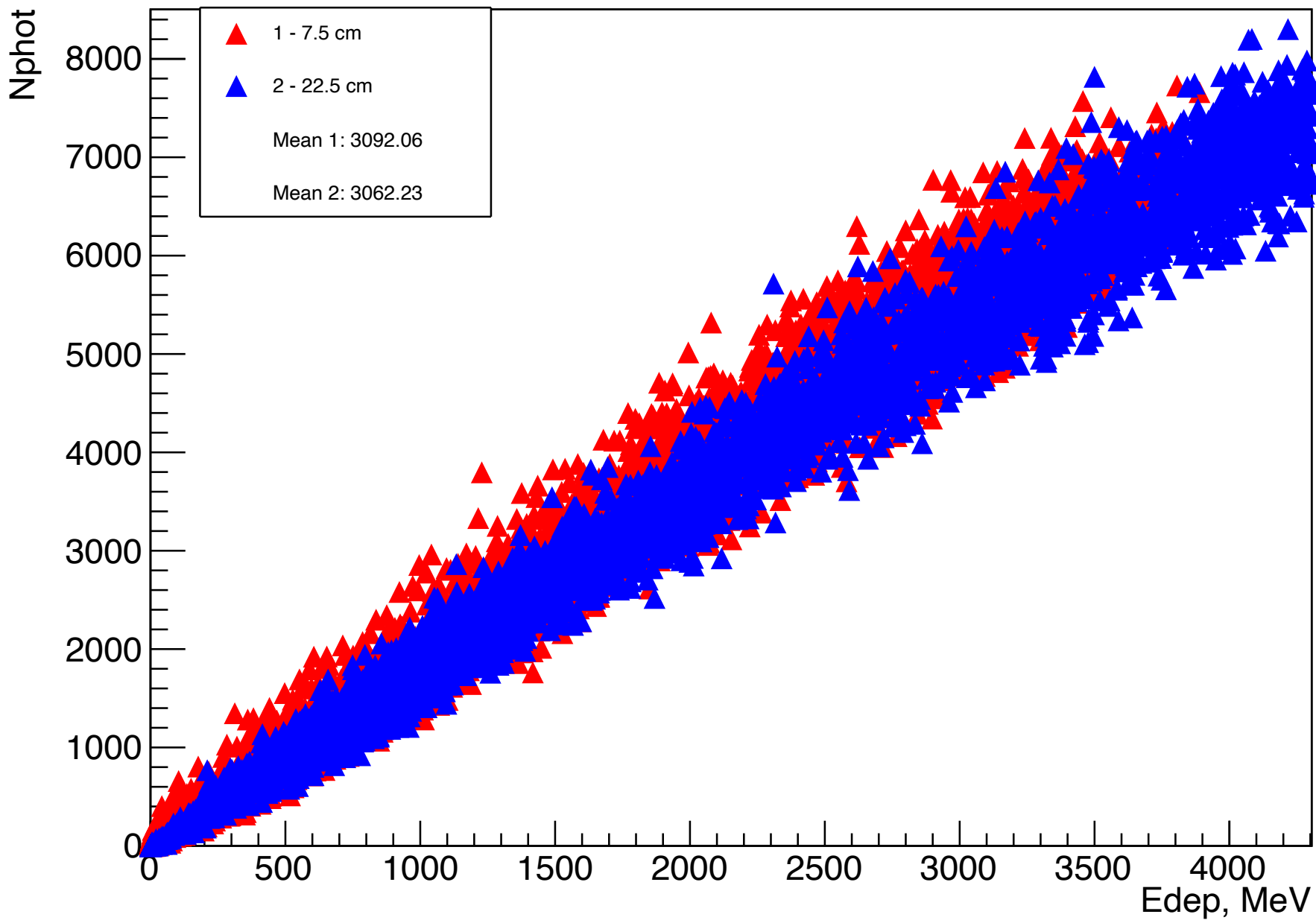

Расположение зеркала: 7,5см/22,5см. Было брошено 5000 первичных электронов и пионов с энергией 10 ГэВ. Точка входа частицы разыграна равномерно от -1,5 см до 1,5 см в плоскости ху.

Красные точки: энергосодержание и оптические фотоны до зеркала;
Синие точки: энергосодержание и оптические фотоны после зеркала.

Mirror SpaCal - fourth - 10GeV

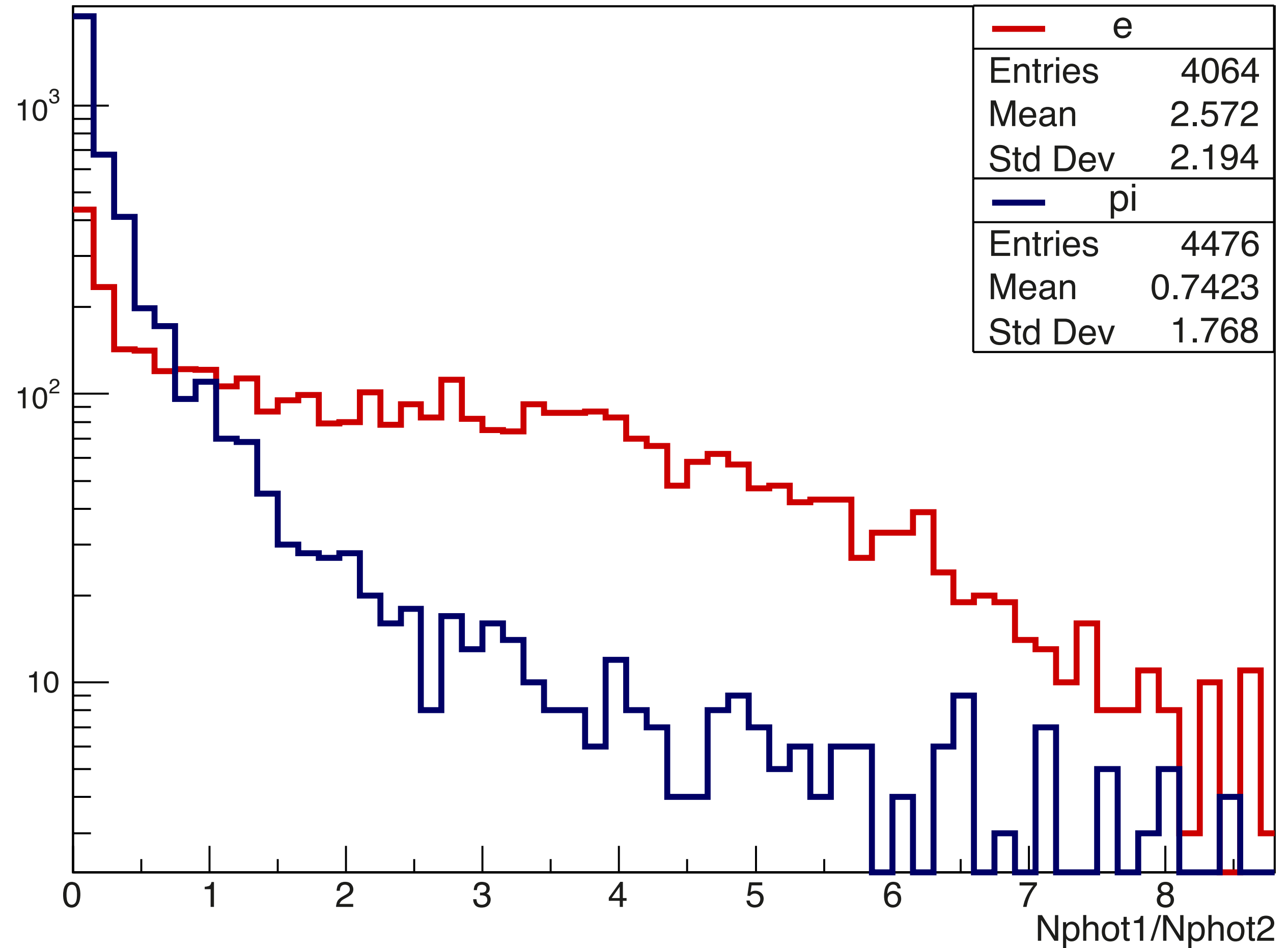

Mirror SpaCal - fourth - pi - 10GeV

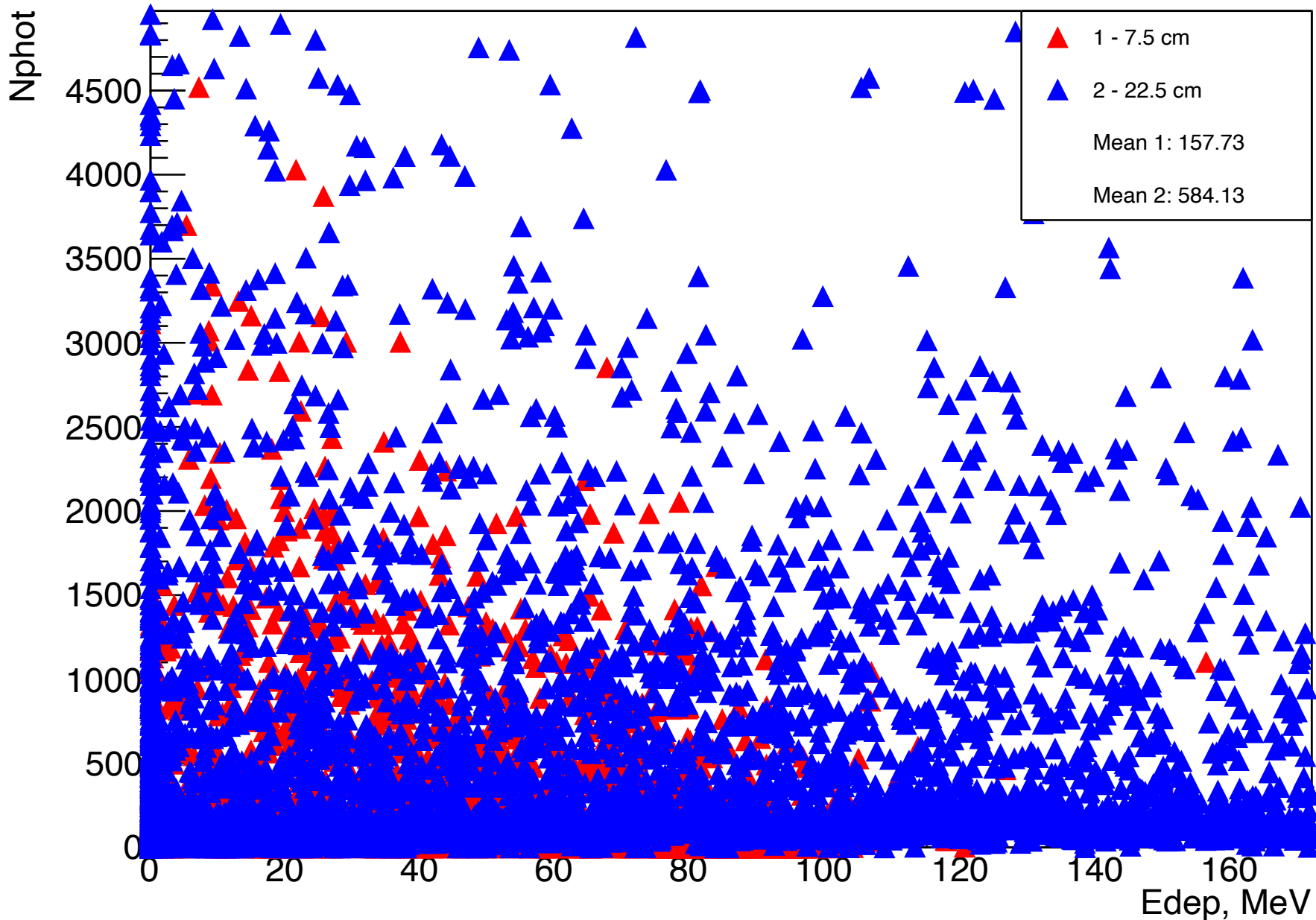

Mirror SpaCal - fourth - 10GeV

