



DeepTreeGAN



Fast Generation of High Dimensional Point Clouds for Calorimeter Simulation

Moritz Scham*, Benno Käch, Dirk Krücker,
Simon Schnake, Kerstin Borrás

IML, 02.02.24

*Funded by Helmholtz AI – grant number: ZT-I-PF-5-3

Speedup with Generative Model?

Goal:

»Provide a generative model for the particle showers in the highly granular calorimeters«

Challenges:

- > Irregular geometry
 - > Number of channels
 - > Sparsity
- ⇒ No ML model powerful enough yet
 - ⇒ Data structure: Point Clouds (PCs)
 - Model architecture independent of calorimeter geometry

Generative Adversarial Networks

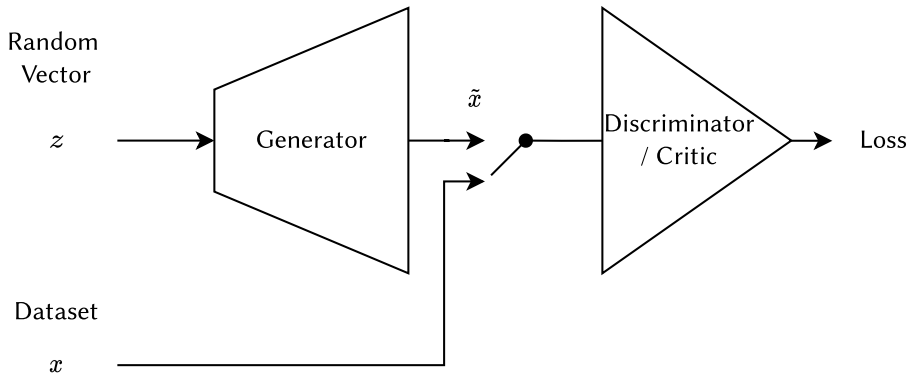

Most Common Approach for PC GANs

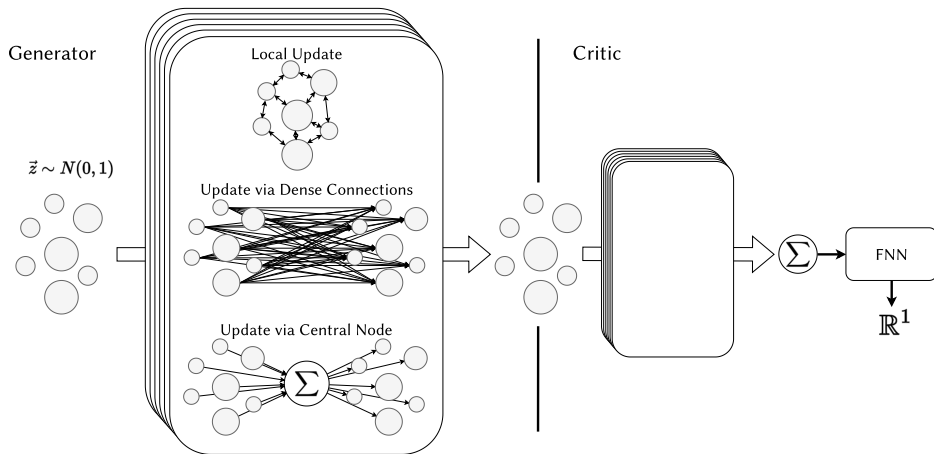

Generator

Core challenge: Upsampling Point Clouds

Same for GAN/VAE/Diffusion+UNet

Naive approach:

(with feedforward neural networks (FFNs))

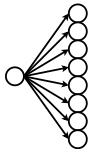

- > Latent Vector \rightarrow FFN \rightarrow PCs
- \Rightarrow Number of parameters explodes
- \Rightarrow Not trainable

DeepTreeGAN:

(Inspired by TreeGAN ARXiv:1905.06292)

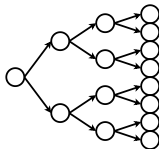

- > FFN projects one particle to multiple particles, repeat to grow a tree
- \Rightarrow Small output space for each FFN
- \Rightarrow Small number of parameters

Physics inspired!

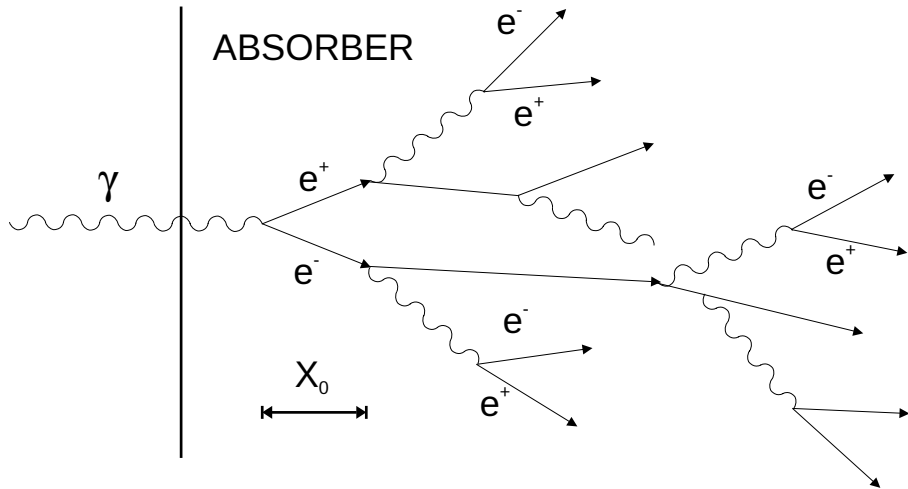

<https://cds.cern.ch/record/1388922>

DeepTreeGAN

Branching

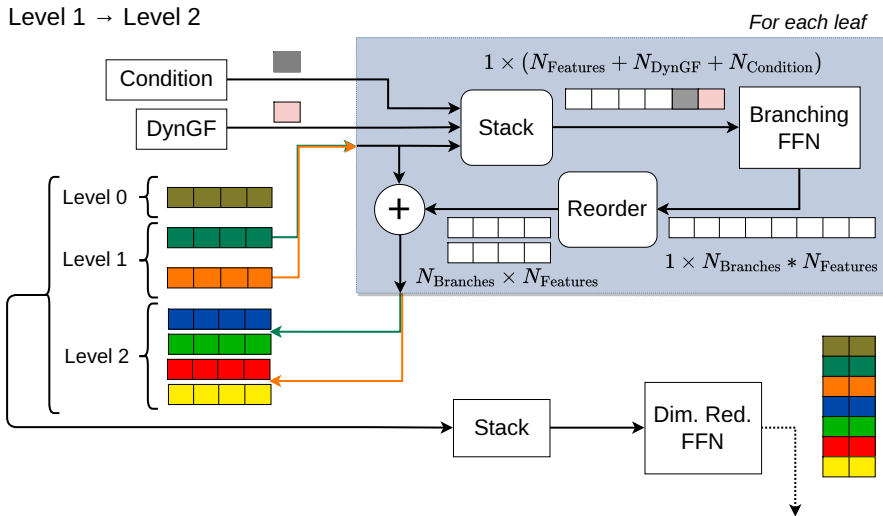

Ancestor Message Passing Layer

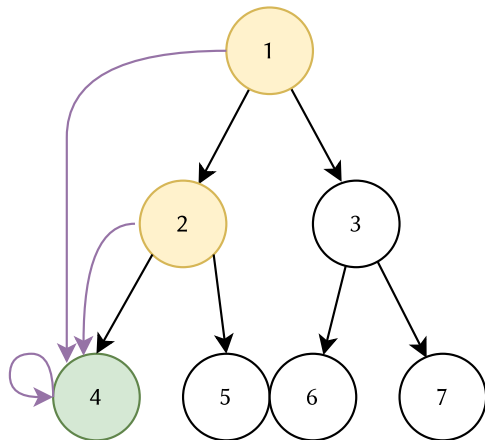

Update Node 4 (w/ Neighbors, Messages)

DeepTreeGAN

Architecture

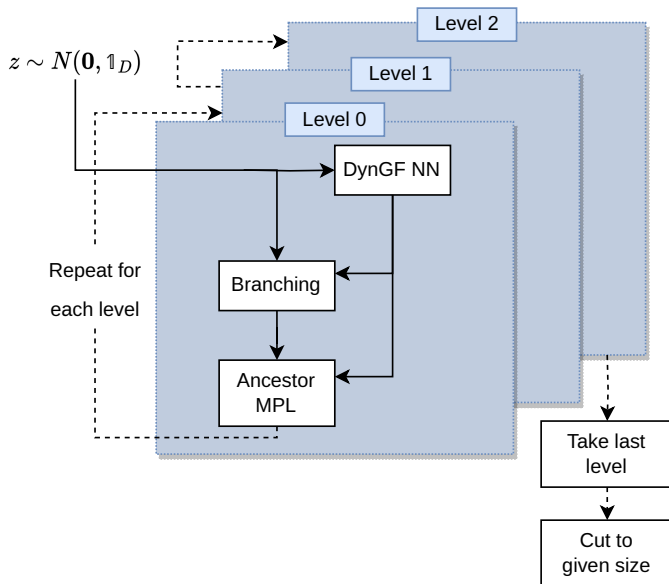

Critic



- > Idea:
Iteratively reduce the number of points
- > Pooling requirements:
 - Differentiable
 - Arbitrary input size
 - Adjustable output size
 - Permutation invariant

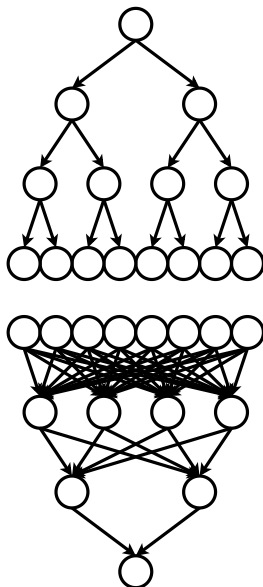

Generator

Critic

Bipartite Attention Pool

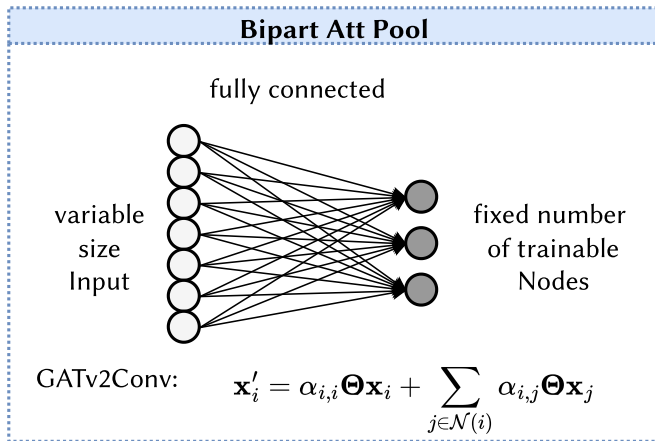

GATConv:ARXIV:2105.14491

Similar approach: PMA blocks from set transformer ARXIV:1810.00825

DeepTree Critic

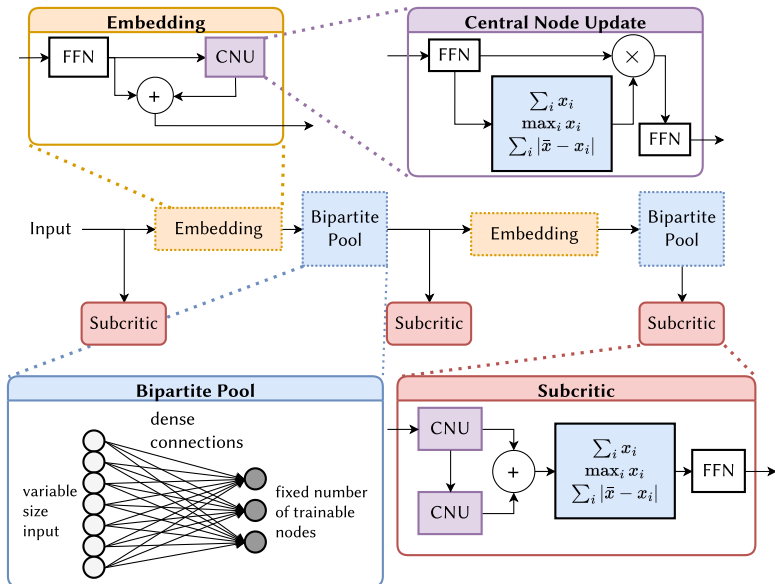

Benchmark on Calochallenge

CaloChallenge

- > Public dataset: DOI 10.5281/ calochallenge .github.io/homepage/
- > 100k GEANT4-simulated electrons showers for training/testing
- > Energies with log-uniform distribution [1 GeV,1 TeV]
- > Concentric cylinder detector geometry
- > 45 layers(z) x 9 radial segments (r) x 16 angular segments (α) = 6480 voxels

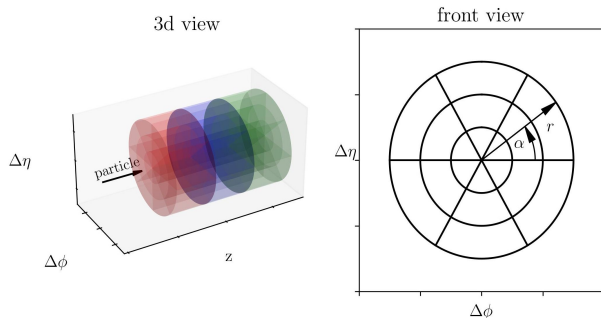

CaloChallenge

- > Generator needs the number of hits from simulation
- > Condition on generator + critic on $\sum_i E_i, \frac{1}{n} \sum_i E_i, n$
- > Postprocessing:
 - Hit collision shifted to neighboring cells (<https://caloutils.readthedocs.io>)
 - Rotate generated showers by a random shift in α

2D – Number of Hits

2D Histogram for 6000 points in 50000 events

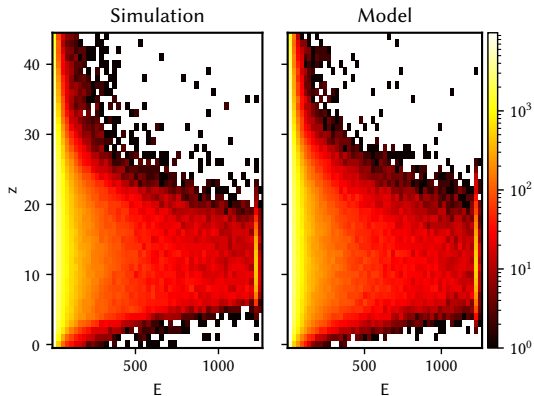

2D Histogram for 6000 points in 50000 events

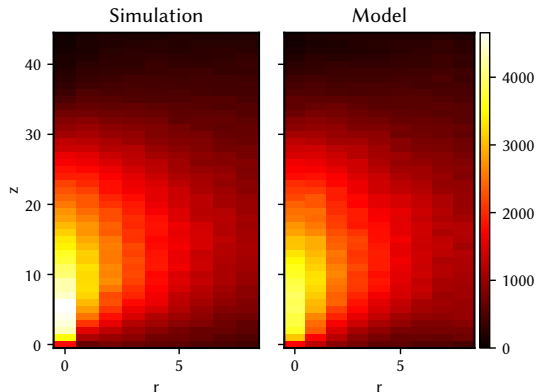

⇒ Looks good!

Benchmarking on JetNet-150

JetNet (ARXIV:2106.11535) provides:

> Dataset

- Public dataset generated with Pythia
- Hadronized jet from pp collisions @ 13 TeV
- Anti- k_T clustered (R=0.8)
- used here: 170k top jets (each)
- Leading 150 constituents by p_T
- Rescaled variables:

$$p_T^{rel} = \frac{p_T^{particle}}{p_T^{jet}}, \quad \eta^{rel} = \eta^{particle} - \eta^{jet}, \quad \varphi^{rel} = \varphi^{particle} - \varphi^{jet}$$

- $\sum p_T^{rel} = 1 \Rightarrow$ rescale model output to 1
- Properties of the constituents relative to the jet

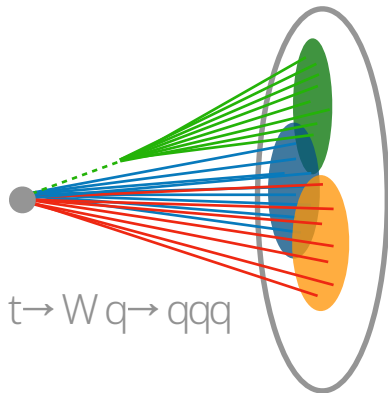

Jet Constituents – Top Jets

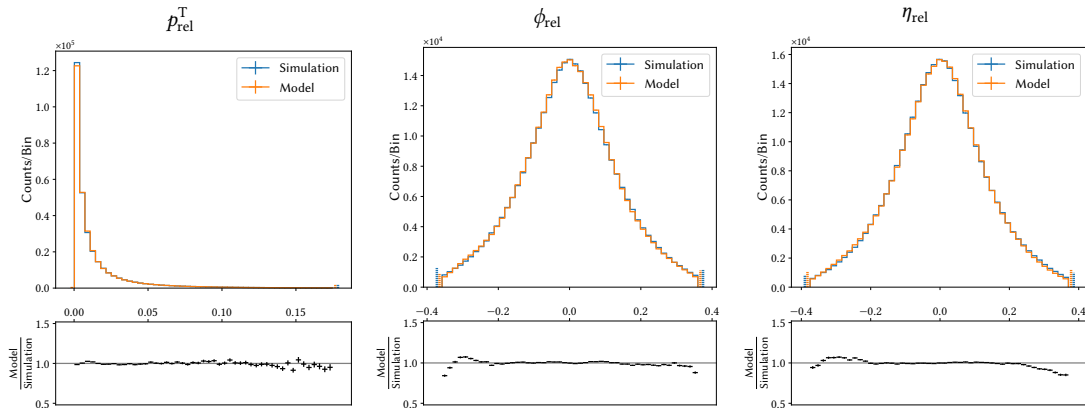

⇒ Looks good!

Global Features – Mass

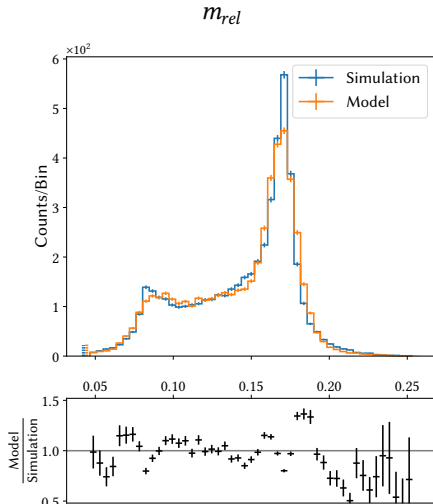

⇒ Not perfect, but pretty good!

Comparison to PC-GANs

EPiC-GAN [arXiv:2301.08128](#) / MDMA [arXiv:2305.15254](#)

- > Metrics from the JETNET library / [arXiv:2211.10295](#)
- > 25k event hold-out sample
- > ‘Limit’ row gives the measured in-sample distance by bootstrapping the hold-out dataset.
- > Lower is better, best in bold

Model	$W_1^M(\times 10^3)$	$W_1^P(\times 10^3)$	$W_1^{EFP}(\times 10^5)$	$FPD(\times 10^4)$
Limit	0.42 ± 0.09	0.12 ± 0.04	1.22 ± 0.32	1.2 ± 0.6
EPiC-GAN	0.69 ± 0.08	0.65 ± 0.03	2.67 ± 0.39	22 ± 1
MDMA	0.57 ± 0.09	0.10 ± 0.02	2.12 ± 0.64	5.3 ± 0.9
DeepTree**	0.77 ± 0.06	0.17 ± 0.02	3.46 ± 0.10	2.5 ± 0.4

⇒ Competitive Results

Conclusion

- > Almost identical architecture for jets and calorimeter showers
- > New, differentiable up/downscaling methods for point clouds
- > Promising approach for scaling to even larger PCs (e.g. HGCal)



Thank you!

DESY. Deutsches
Elektronen-Synchrotron
www.desy.de

Moritz Scham*, Benno Käch, Dirk Krücker,
Simon Schnake, Kerstin Borrás
moritz.scham@desy.de

Temporary page!

\LaTeX was unable to guess the total number of pages correctly. As there was some unprocessed data that should have been added to the final page this extra page has been added to the document. If you rerun the document (without altering it) this surplus page will go away, because \LaTeX now knows how many pages to expect for this document.