

High gradient C band Cu and CuAg structures at cryogenic conditions

Mitchell Schneider

Motivation

- C band accelerating technologies service the sweet point between X-band and L-band
 - C band and have large irises like L band for high charge beams $\sim 10\text{nC}$
 - C band can have comparable fields to X-band $>200\text{ MeV/m}$
 - C band can also be used for proton and electron machines
 - Making it extremely useful for collider's but also practical applications for medical and industrial

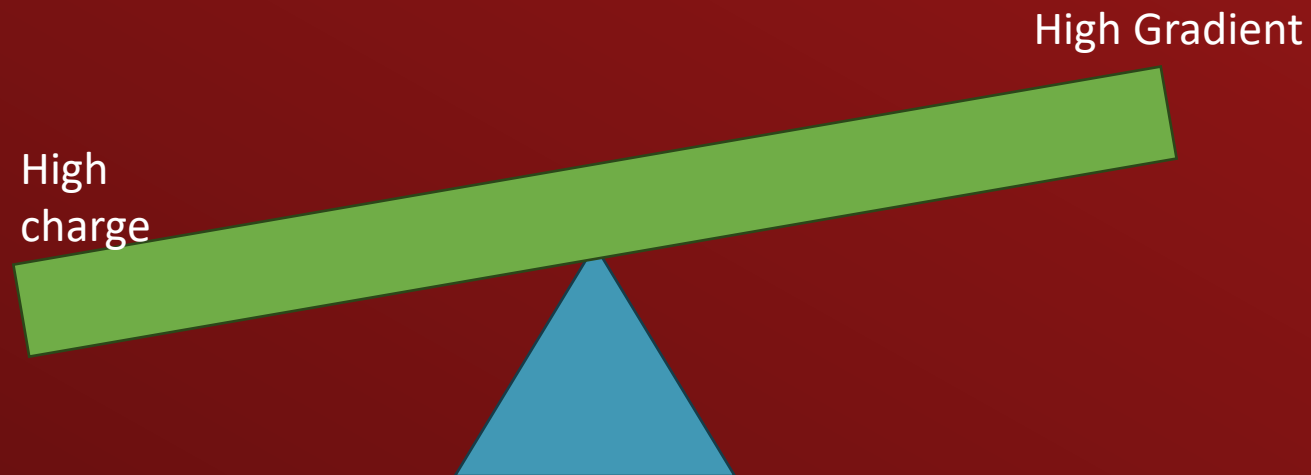

Motivation form X-band work at SLAC

- Valery Dolgashev et al In X-band
 - CuAg show Improvement in gradient
 - w/ Small concentrations of silver <1%
 - Cu in Cryogenic conditions has significant improvement over pure copper

But no one has ever tested structures made from Hard unbrazed CuAg in cryogenics

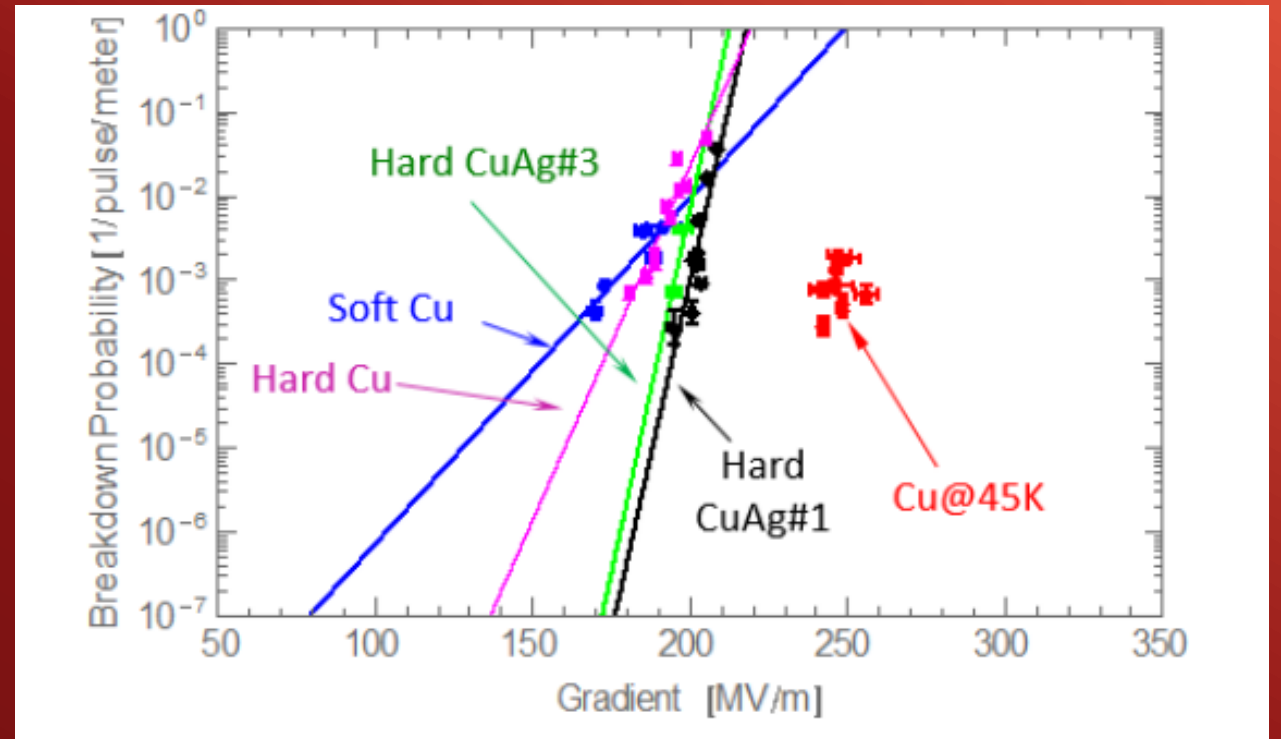

A. Cahill et al. IPAC17

SLAC/LANL C-band Collaboration

- We Fabricated two structures one form pure copper and the other with the CuAg alloy of 0.08%
 - Cavity were braced structures
- Structures were a scale design of S-band deflector cell design by SLAC
- Structures were designed using distributed coupling techniques ACE2P
- LANL Tested both structures

M. Schneider et al. Appl. Phys. Lett. 121, 254101

Parameter	Cu ($v=0.5c$ Proton)	Cu ($v=c$ Electron)
Length	1.58 cm	
a/λ	0.0525	
σ	58 MS/m	
Q_0	9762	
Q_{ext}	10165	
R_s	61.51 M Ω /m	115.81 M Ω /m
E_a	62 MeV/m $\sqrt{P[MW]}$	81 MeV/m $\sqrt{P[MW]}$
E_p/E_a	2.94	2.04
$H_p * Z_0/E_a$	1.63	1.13

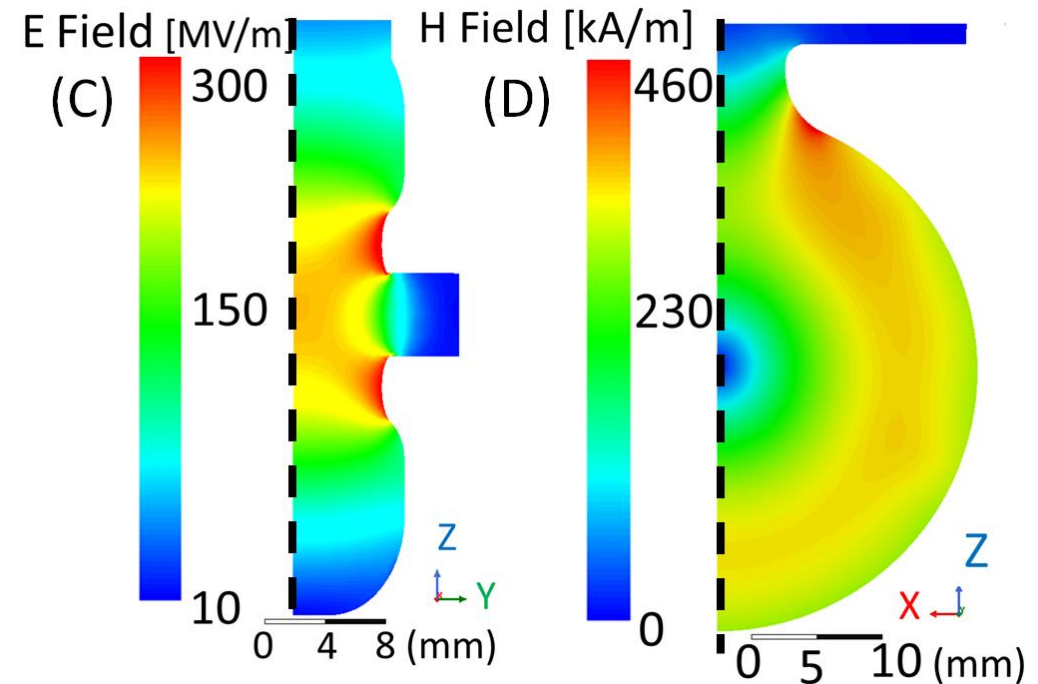
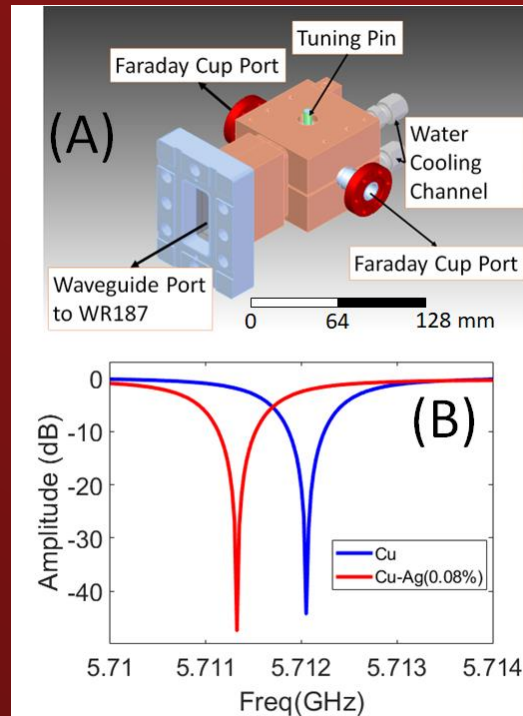

SLAC/LANL C-band Collaboration

M. Schneider et al. Appl. Phys. Lett. 121, 254101

- Our results were factor five higher than previously reported results
- Fields were comparable with X-band
- CuAg show 20% higher fields than Cu
- Evidence showed the breakdown rate was not dominated by pulse heating
- Due to the design of the structure having the maximum in the modified poynting far from Iris

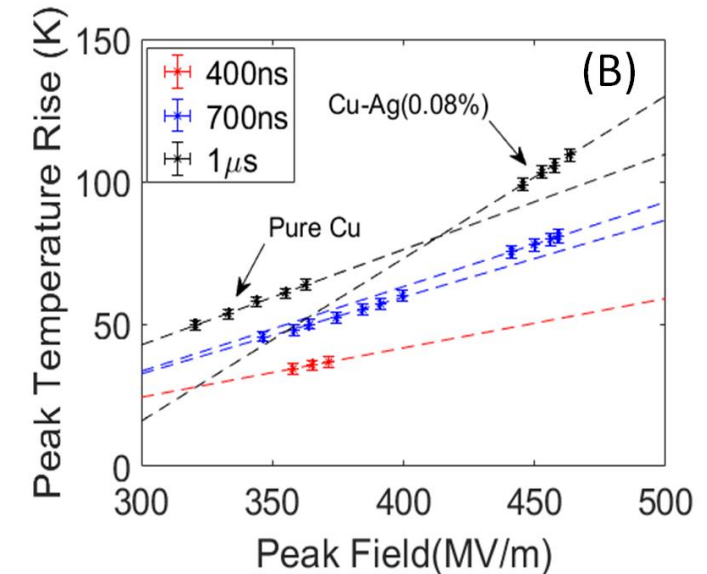
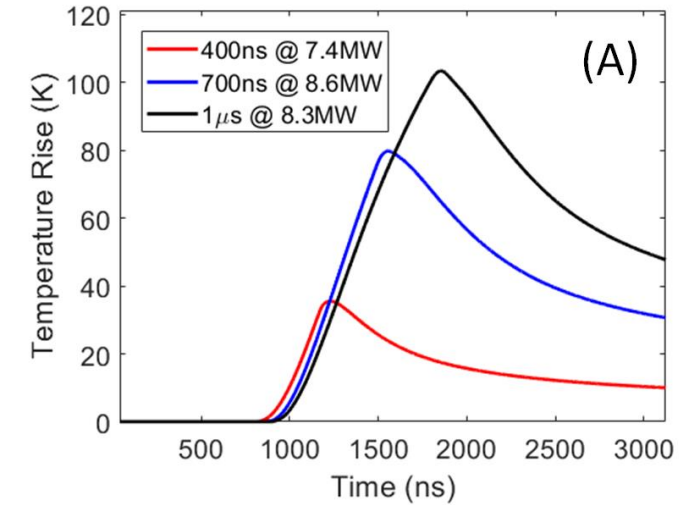
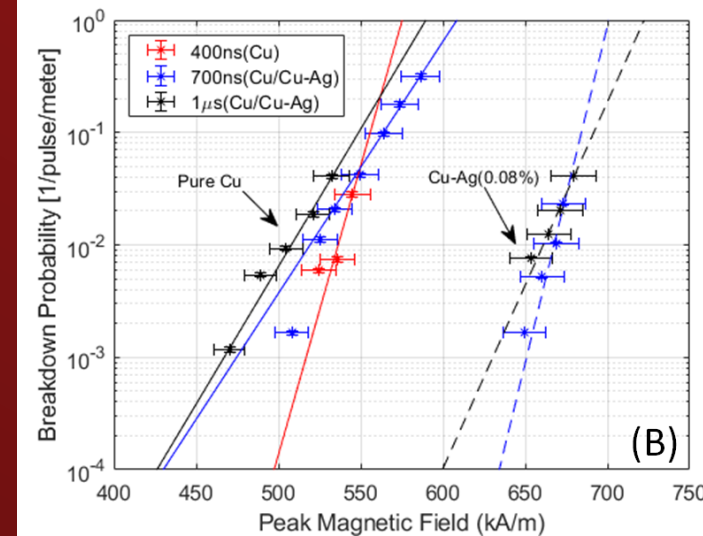
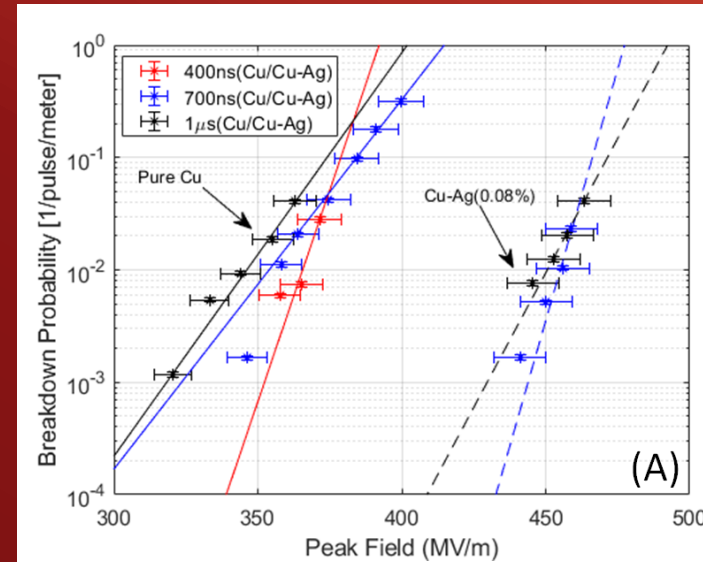
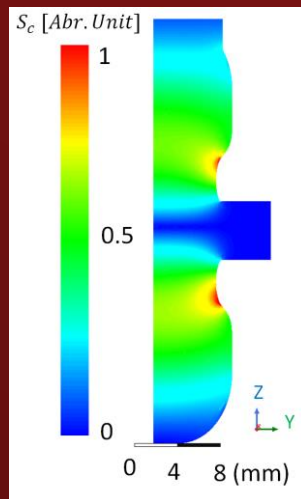

Why go cool

M. Schneider et al. Appl. Phys. Lett. 121, 254101

- Contradicting conditions improve conductivity
- Dislocation defects are less provident
- Higher shunt impedance means less power consumption and higher possible achievable gradient
- Iris

Parameter	Cu ($v=0.5c$ Proton)	Cu ($v=c$ Electron)
Length	1.58 cm	
a/λ	0.0525	
σ	58 MS/m	
Q_0	9762	
Q_{ext}	10165	
R_s	61.51 M Ω /m	115.81 M Ω /m
E_a	62 MeV/m $\sqrt{P[MW]}$	81MeV/m $\sqrt{P[MW]}$
E_p/E_a	2.94	2.04
$H_p * Z_0/E_a$	1.63	1.13

Conductivity
increases by ~2.5
CU and CuAg ~3

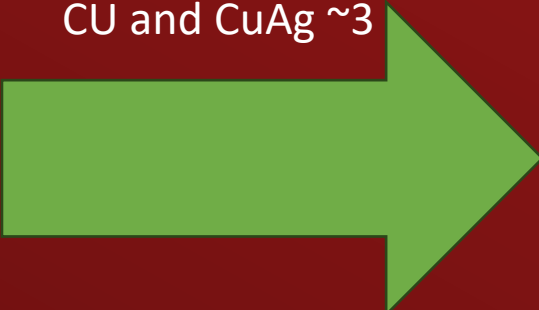

Parameter	CuAg	Cu
Temp	77K	
Freq0	5.71455 GHz	
Ls	1.58 cm	
beta	2.97	2.683
Q0	29,695	25,697
Rs	352 Mohm /s	305 Mohm /s
Ea*sqrt(1 MW)	141 MeV/m	131 MeV/m

Experimental design and constraints

- From LANL results we know CuAg performs better than copper
- What is the performance of CuAg at cryogenic temperatures?
 - Will it perform similar to Cu at cryogenic temperatures or will be an additive effect of CuAg effect+ the cryogenic effect

Both structures tested simultaneously on a hybrid manifold to subject structures to the same conditions

Testing limited to two week maximum

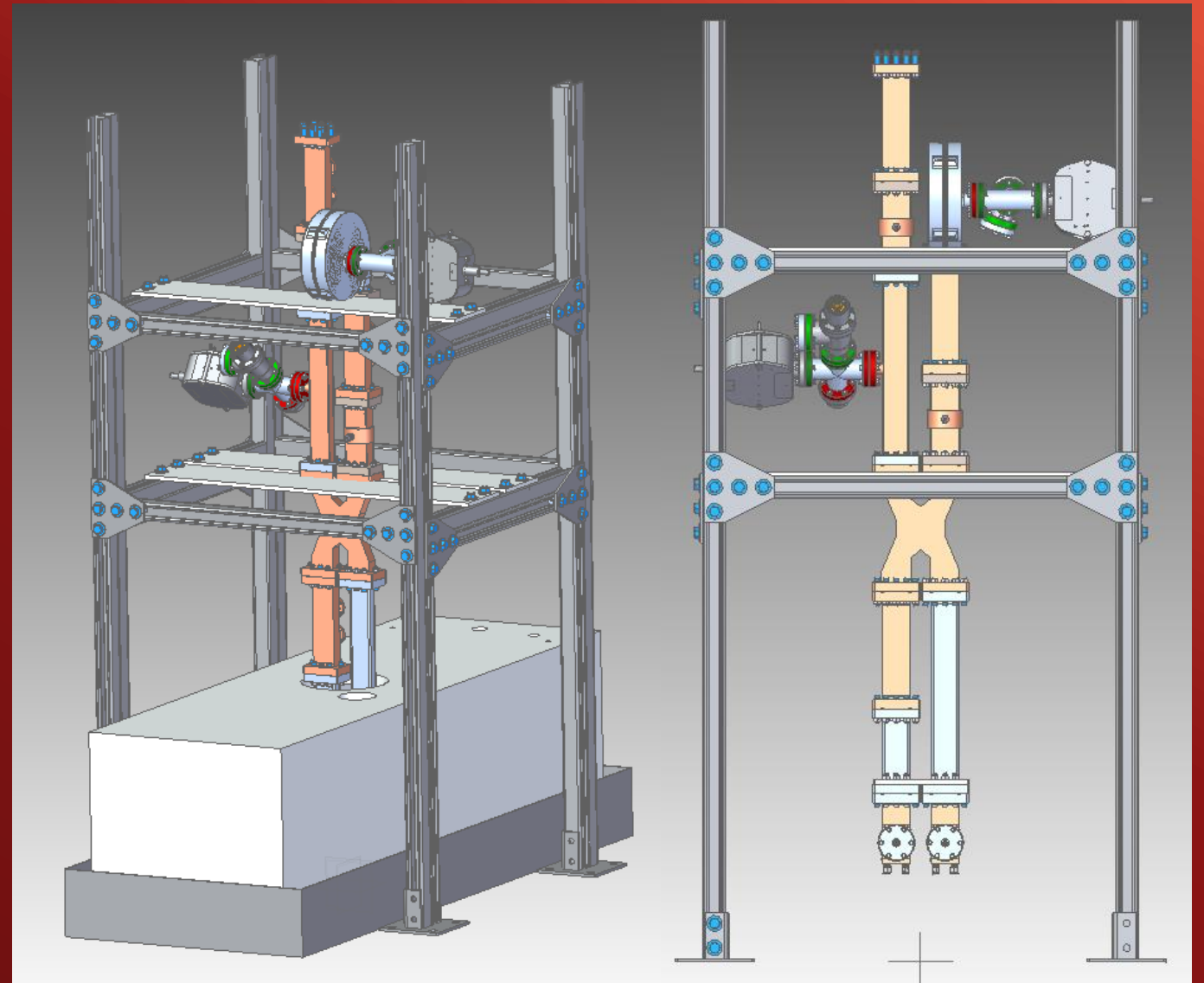

Directional coupler @	Directional coupler port	Description
copper cavity	SA1	Forward power to copper cavity
copper cavity	SB1	reflected power from Copper cavity
load	SC1	reflected power from the load
load	SD1	forward signal from full assembly

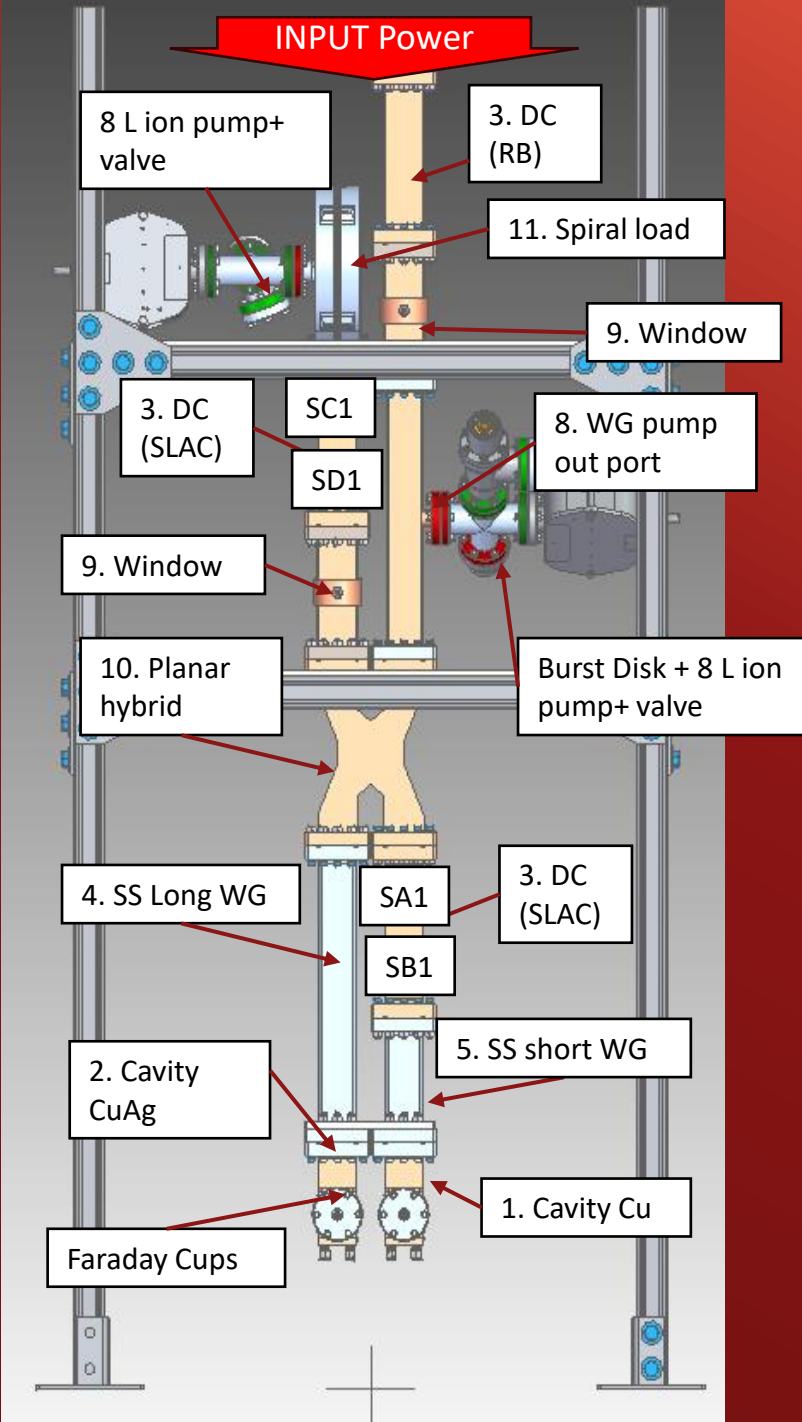

- Stainless steel waveguide used as thermal breaks
- Spiral load used

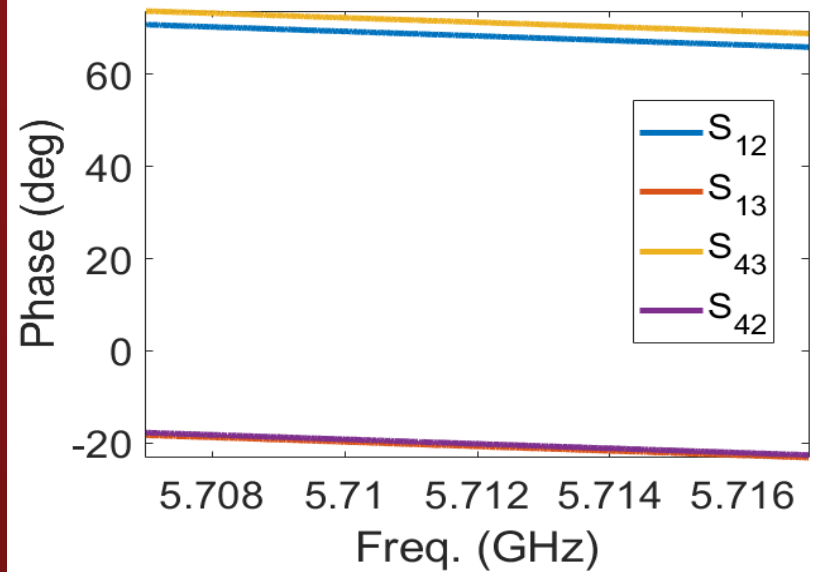
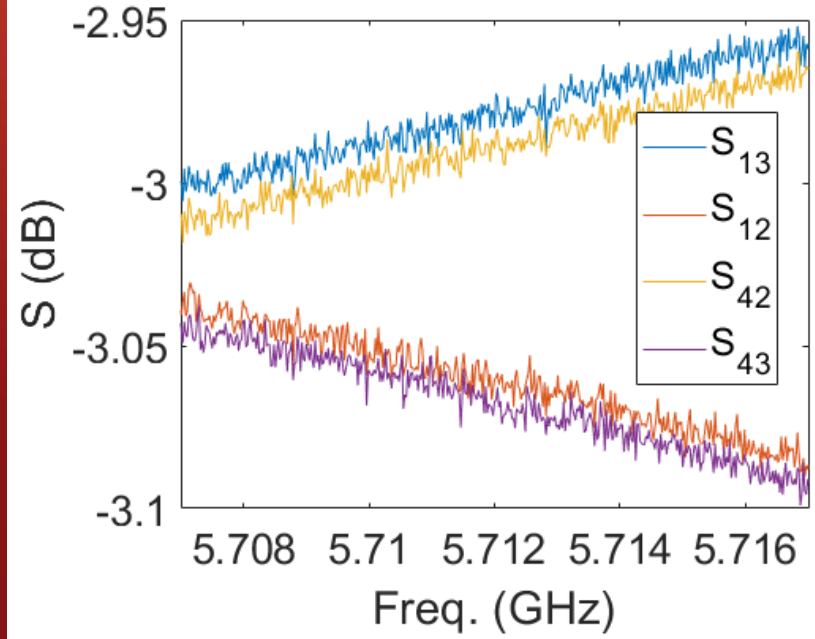
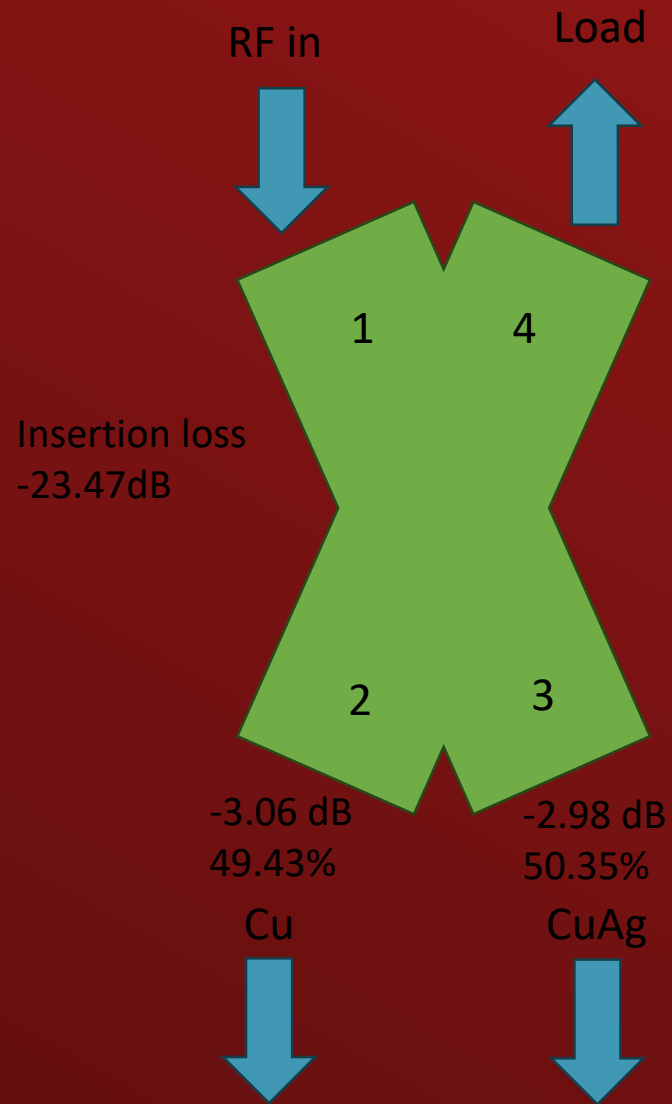

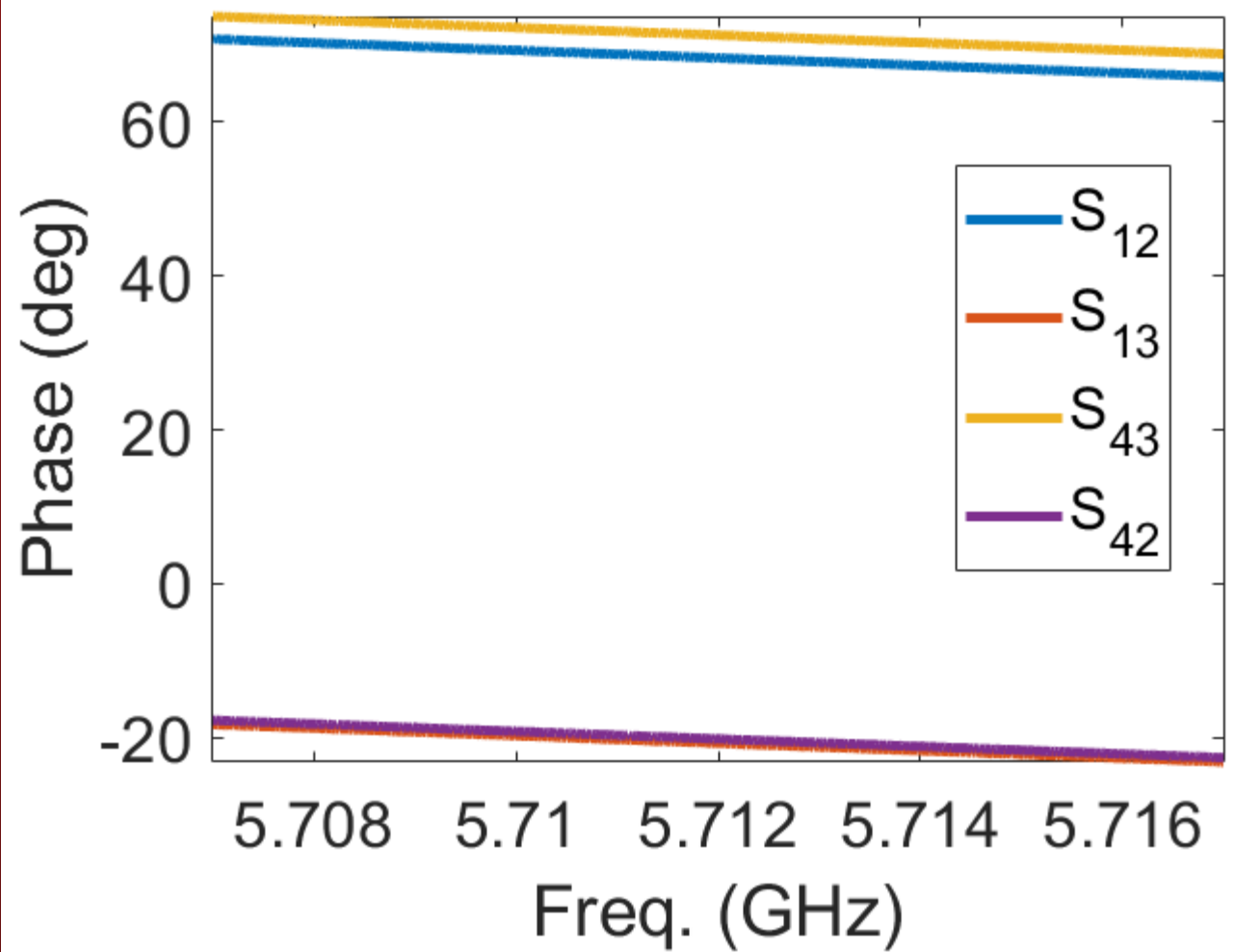

There appears to be a phase shift between at port one may be best to use port 4 due to its ability to not have a phase shift

Cavity Tuning Results

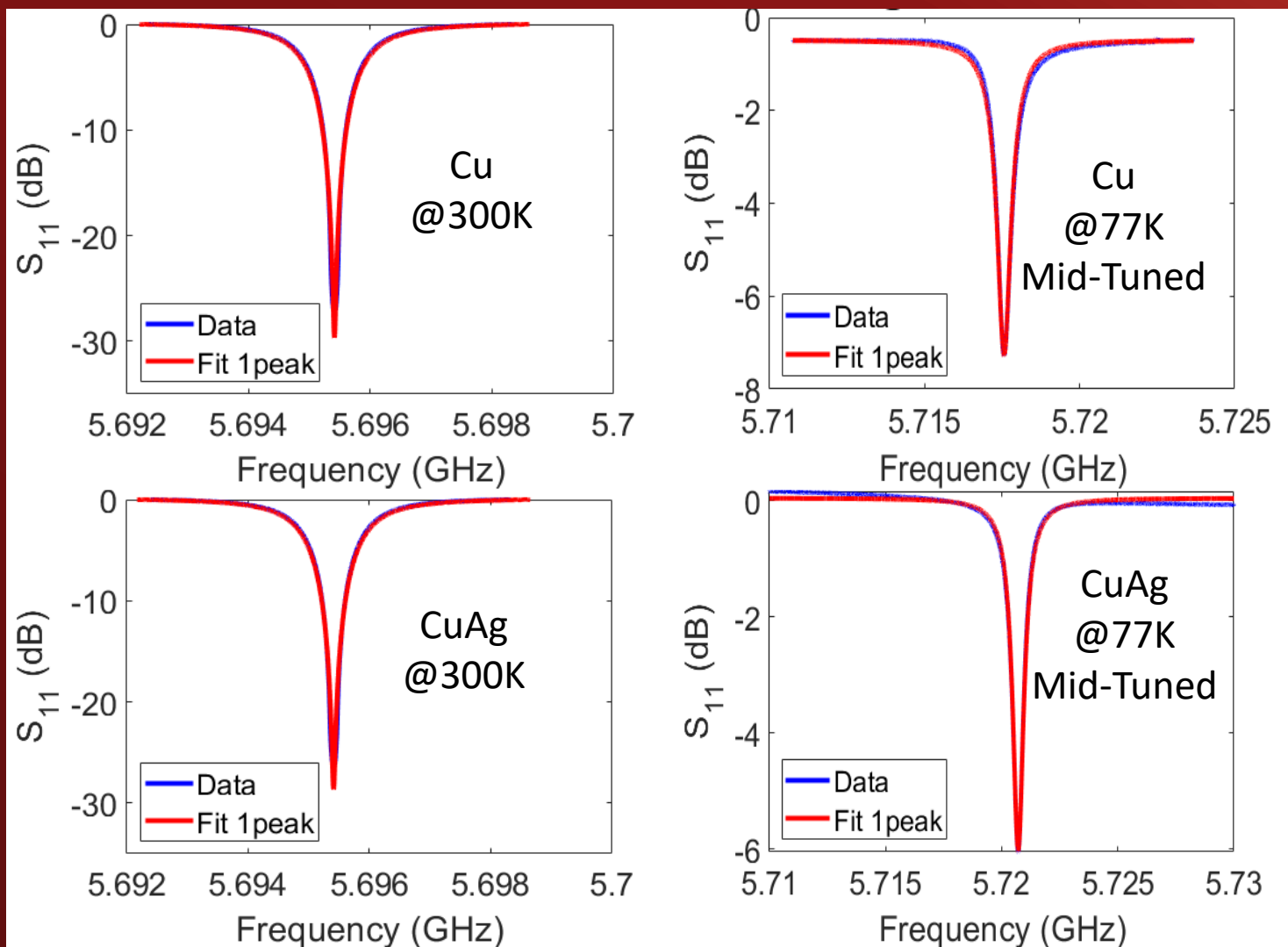

Parameters	Cu @300K	CuAg @300K	Cu @77K Mid-Tuned	CuAg @77K Mid-Tuned
f_0 (GHz)	5.695408	5.695408	5.7176	5.7176
Q0	9,8047	9,881	25,697	29,695
Qe	9,192	9,188	9,577	9,269
β	1.0667	1.0755	2.683	2.97
χ^2	0.3800	0.3038	0.2473	0.2783

Post experiment dunk test over Temp

Knowing that the cavity before testing showed no change due to cryogenics

We also wanted to know what the quality factor as a function of temperature look like for both cavities

Results showed that the trend for both cavities were consistent

Data collection was automated and synchronized with temperature sensor

Some damage appear to occurred in the copper silver structure causing a decrease in the Q value after testing this was due to observed beam loading

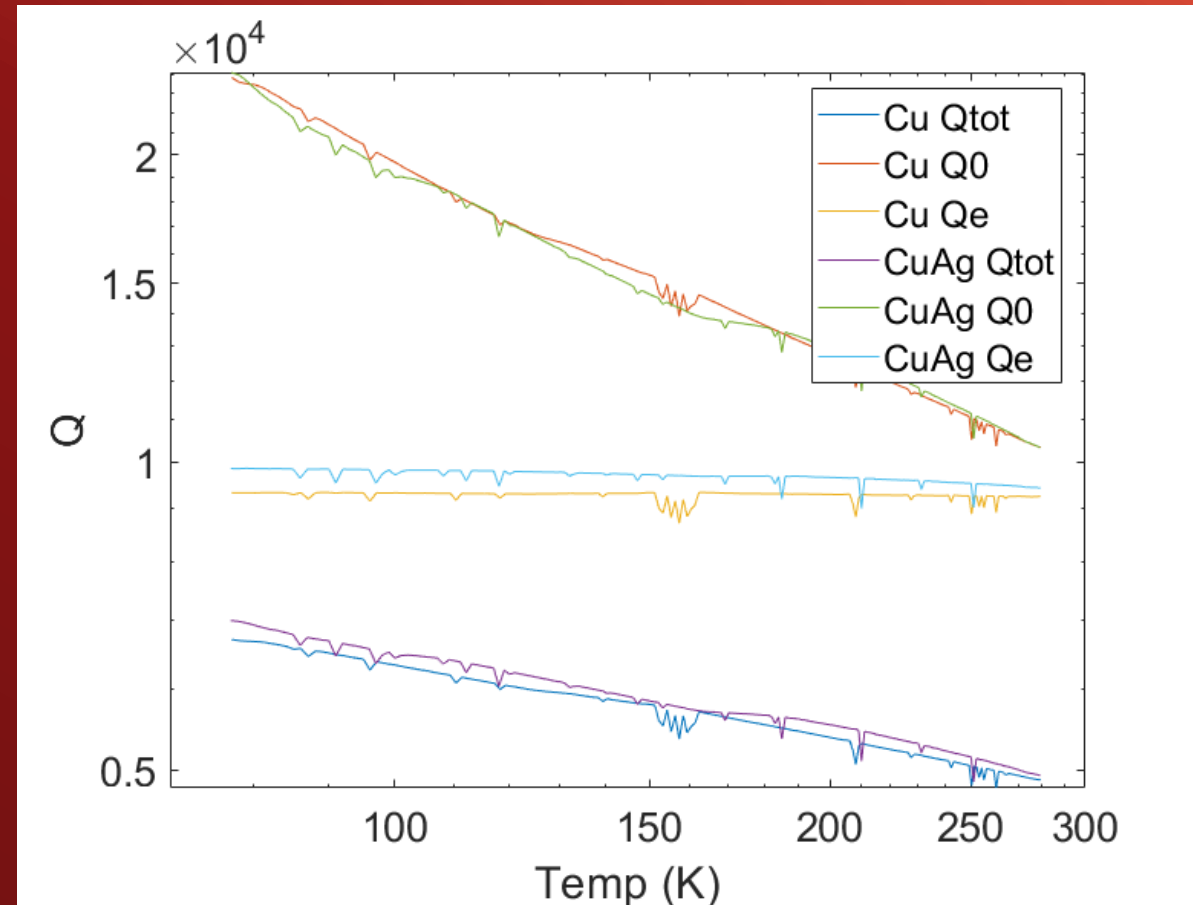

High power testing plan

Conditioning

400 ns up to 5 MW into each cavity

700 ns up to 5 MW into each cavity

1 microsecond up to 5 MW into each cavity

Limit for moving up is <100 breakdowns/hour at 100 HZ for conditioning

Increase in steps of 300 kW

Diagnostics:

Fwd and reflected power from waveguide directional couplers on load, one on Klystron, on the Cu cavity

Two faraday cups on each cavities

Records:

Record ~20 typical traces at each setting

Record all 10 diagnostics if possible – (SA1, SB1, SD1, FC1, FC2) Extra (FC3, FC4)

Parameter	CuAg	Cu
Temp	77K	
Freq0	5.71455 GHz	
Ls	1.58 cm	
beta	2.97	2.683
Q0	29,695	25,697
Rs	352 Mohm/s	305 Mohm/s
$E_a \cdot \sqrt{1 \text{ MW}}$	141 MeV/m	131 MeV/m

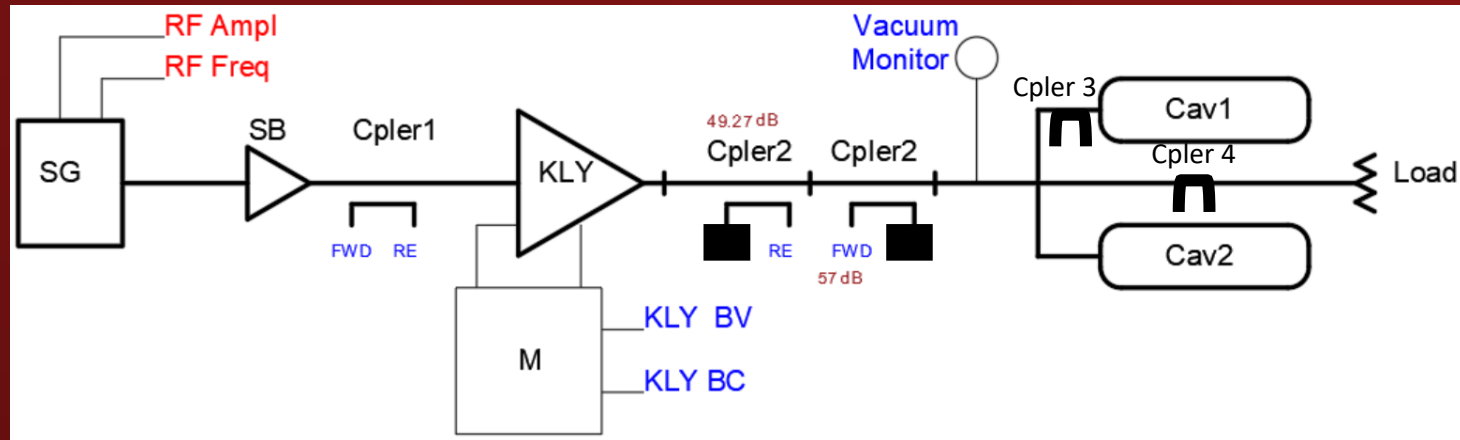

Executive summary conditioning process

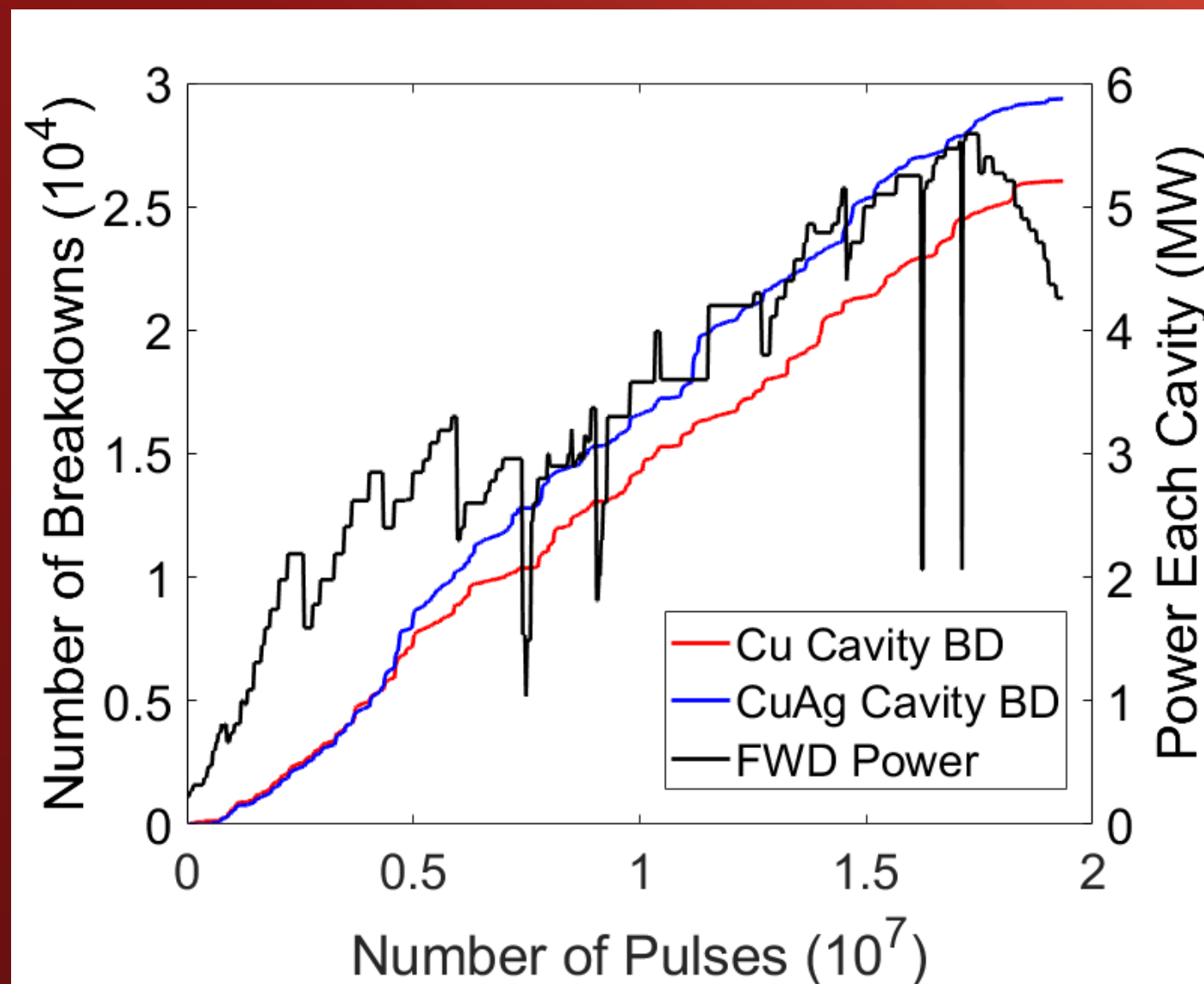

Model for Cu 1MW 10/16/23 data

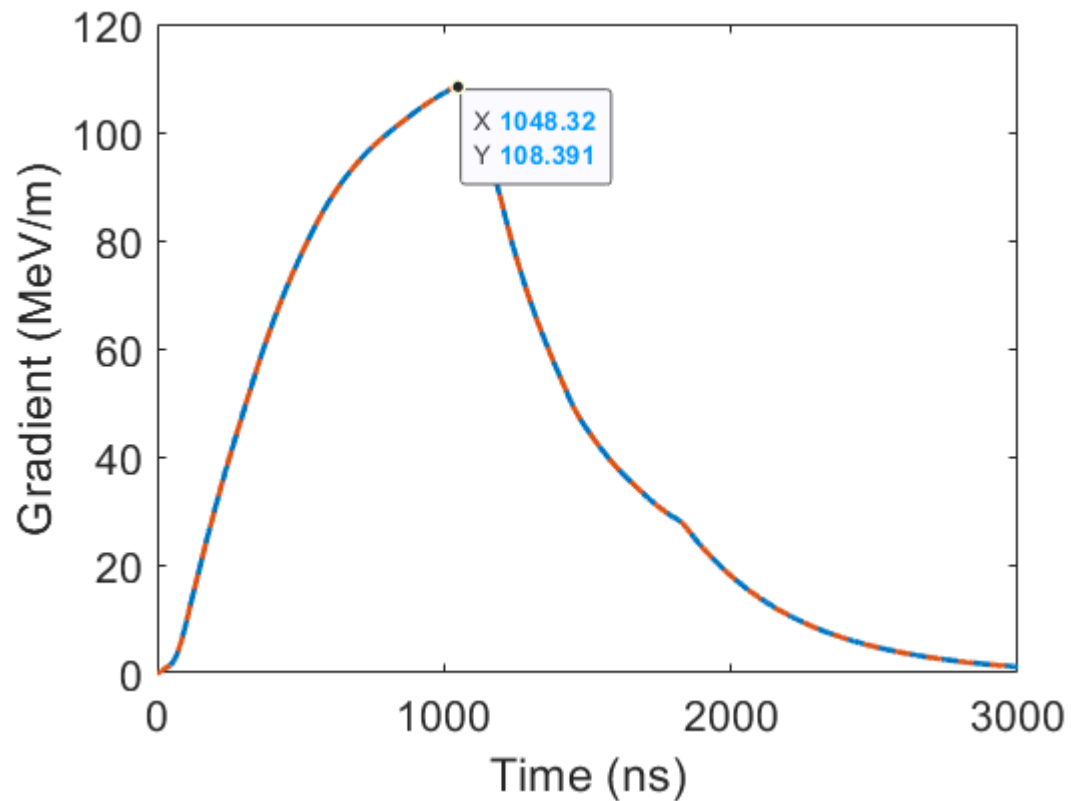
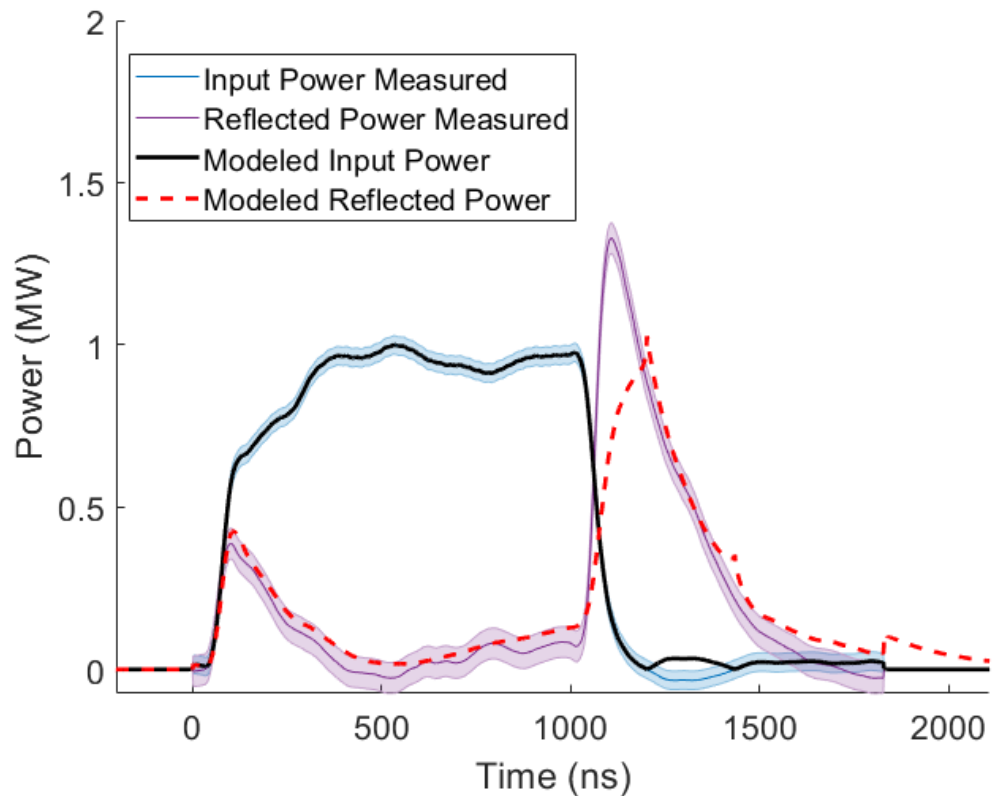

Previous beam loading results for cold copper

A. Cahill Results for onaxis three cell copper cold cavities showed similar results in created a time-dependent Q factor code regime

His results showed a similar interpolation between 2 Q values before and after beam loading and a transitional region

I modeled this as a function of a modified Fermi direct distribution

$$Q_0(t) = Q_{0bL} + \frac{Q_{0CT} - Q_{0bL}}{1 + \exp\left(\frac{t-t_m}{\tau}\right)}$$

Q_{0CT} = Q factor for cold test

Q_{0bL} = Q factor during beam loading

t_m = the time or beam loading starts to occur

τ = time constant

SECTION TITLE AND/OR DEPARTMENT

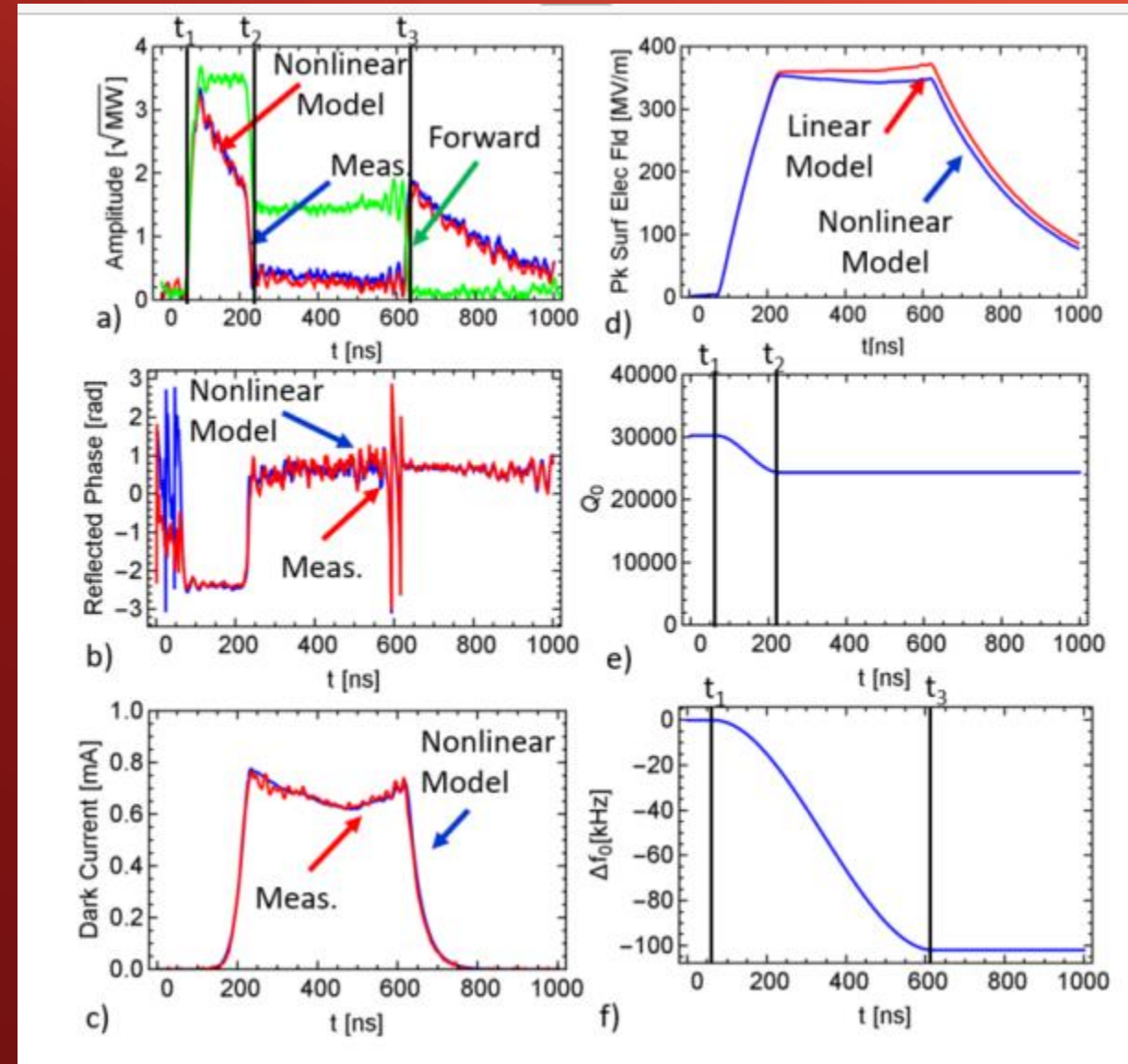

Evidence of beam loading in unsaturated regimes

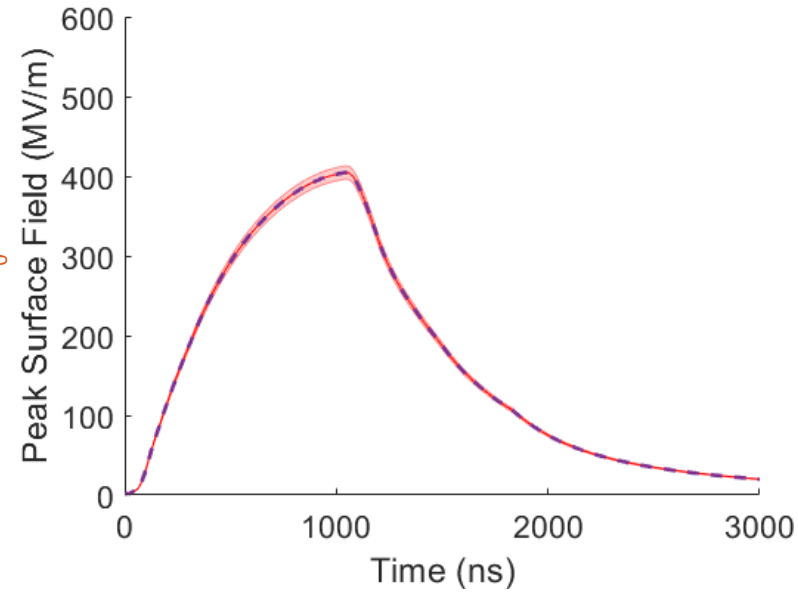
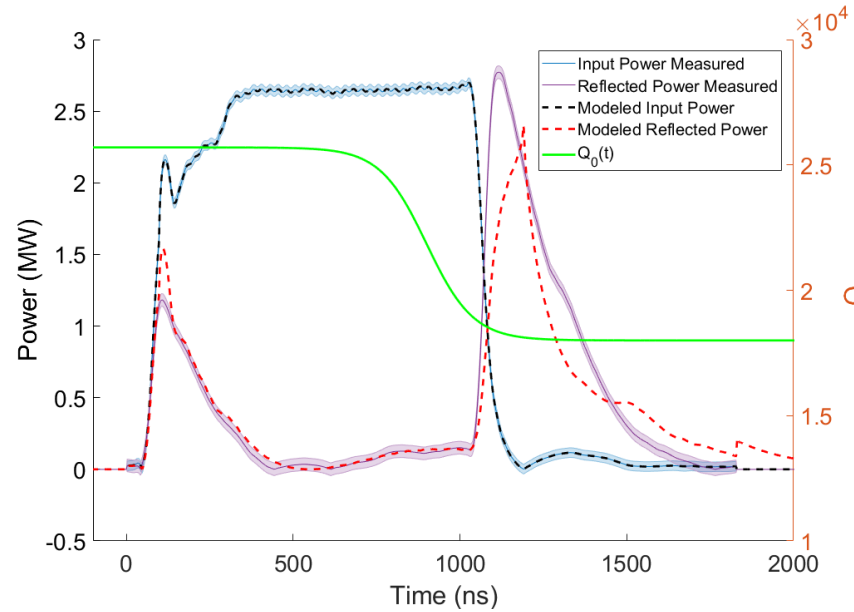

2.7 MW Shows first evidence of beam loading near end of pulse

Suppress Q 18,000

$Q(t)$ shows best fit

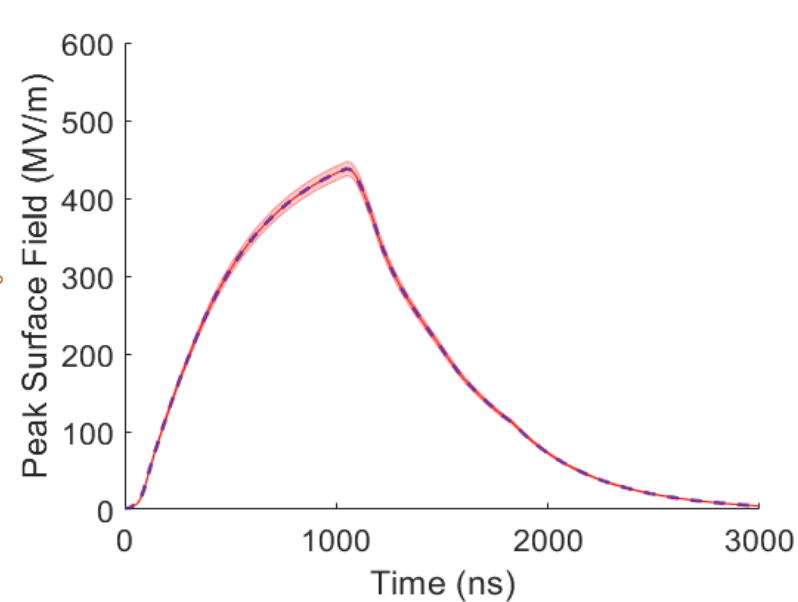
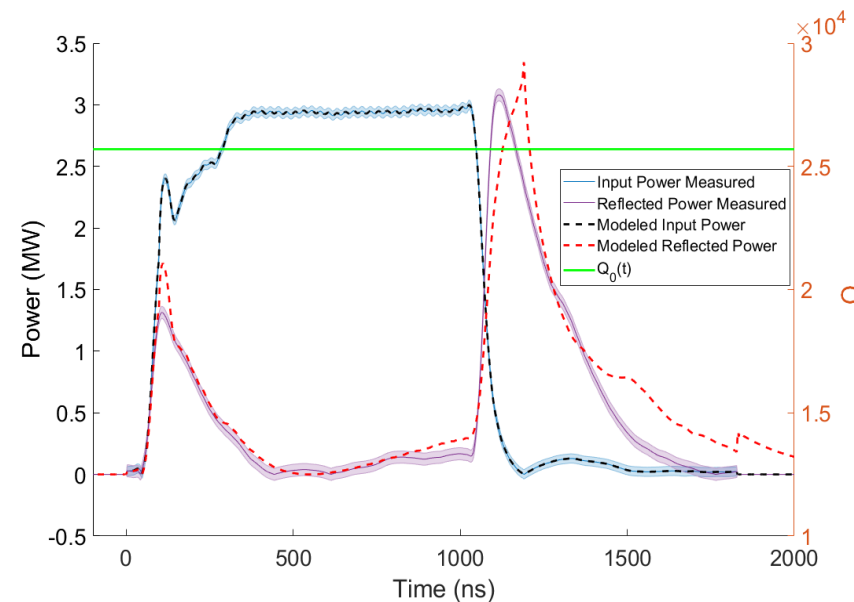

Showing minimal difference on final surface field calculations

Synchronizing pulse and background noise

Time jitter in data means that not all pulses were synchronized postprocessing
synchronized all pulses

Crucially to determine the error bars in the electric field we need to find the variability in the forward power amplitudes between pulses

Calculate background noise needed later for background subtraction
before HV Jitter

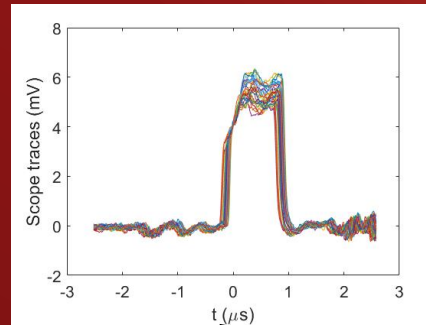

Determine the deviation from the flat top as the klystron signal is flat but there is directionality issues in the forward power from the cavity and subtract this out to create a flattened forward power

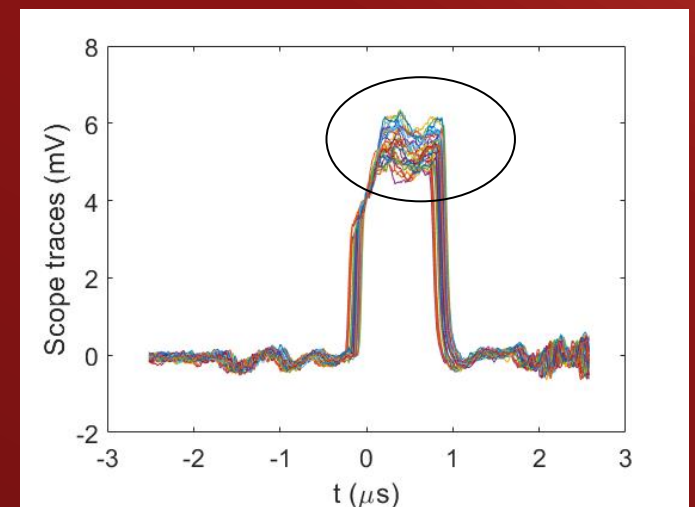
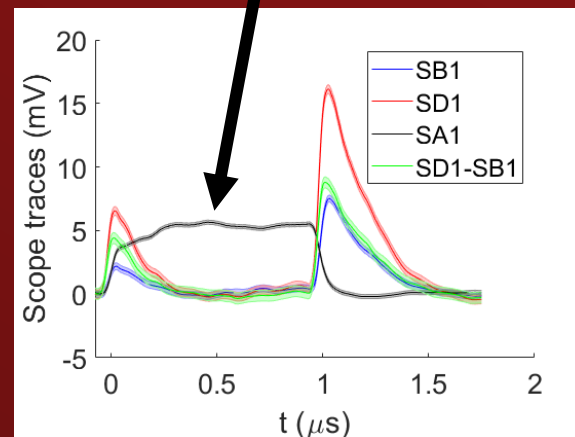
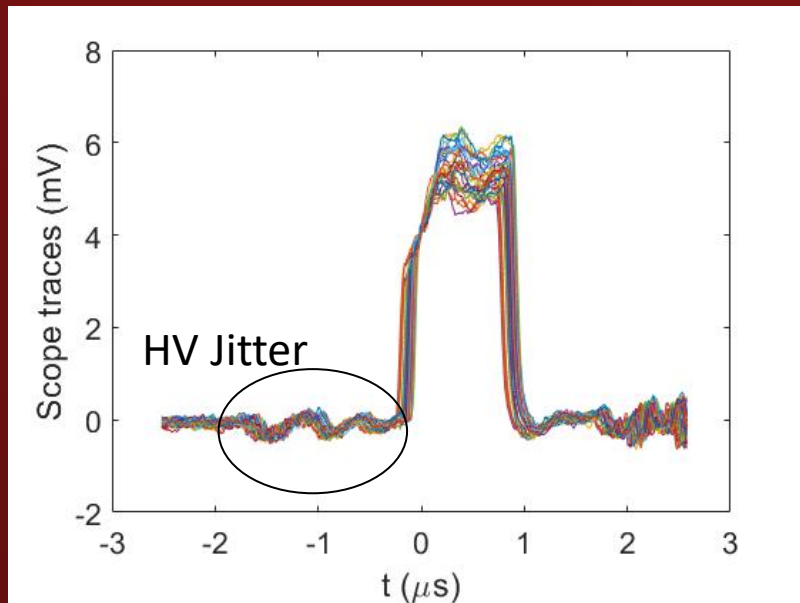

16. BDR results

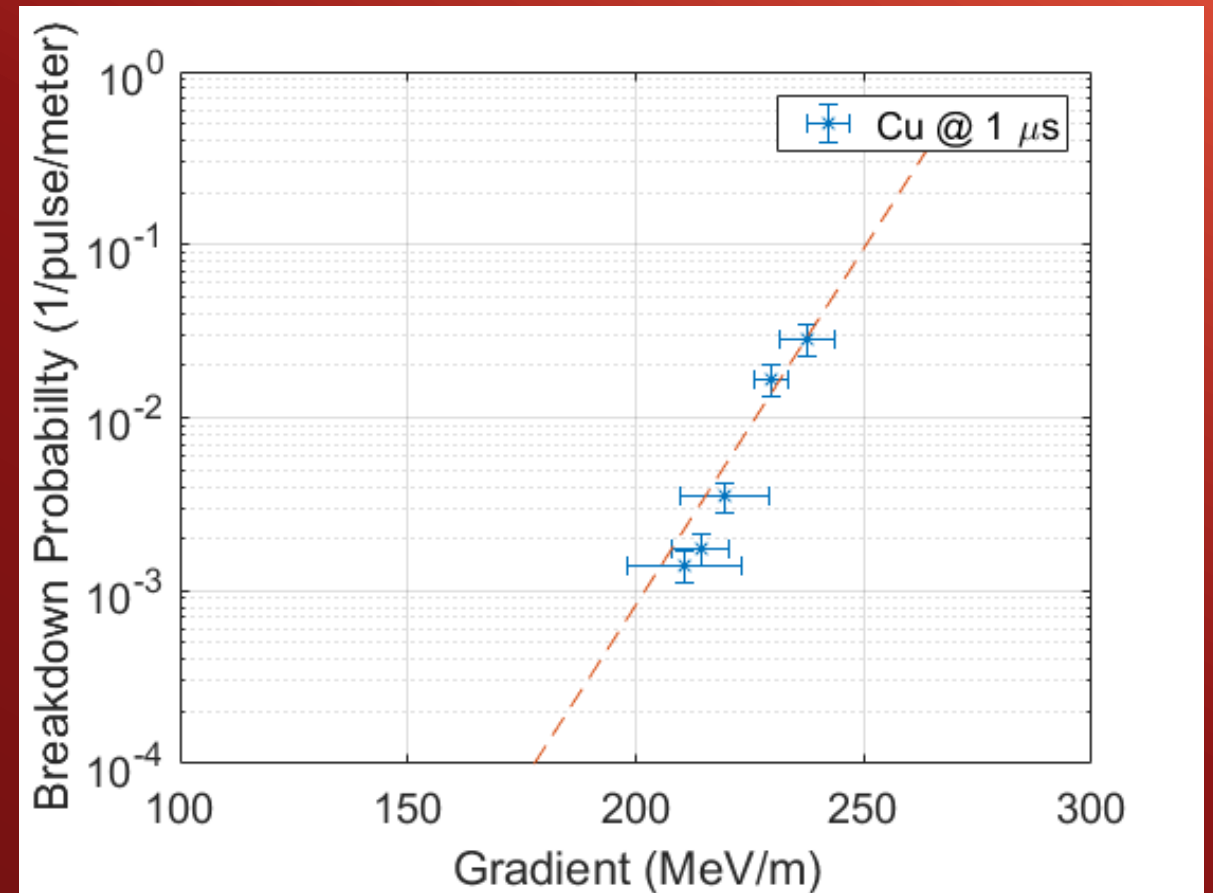
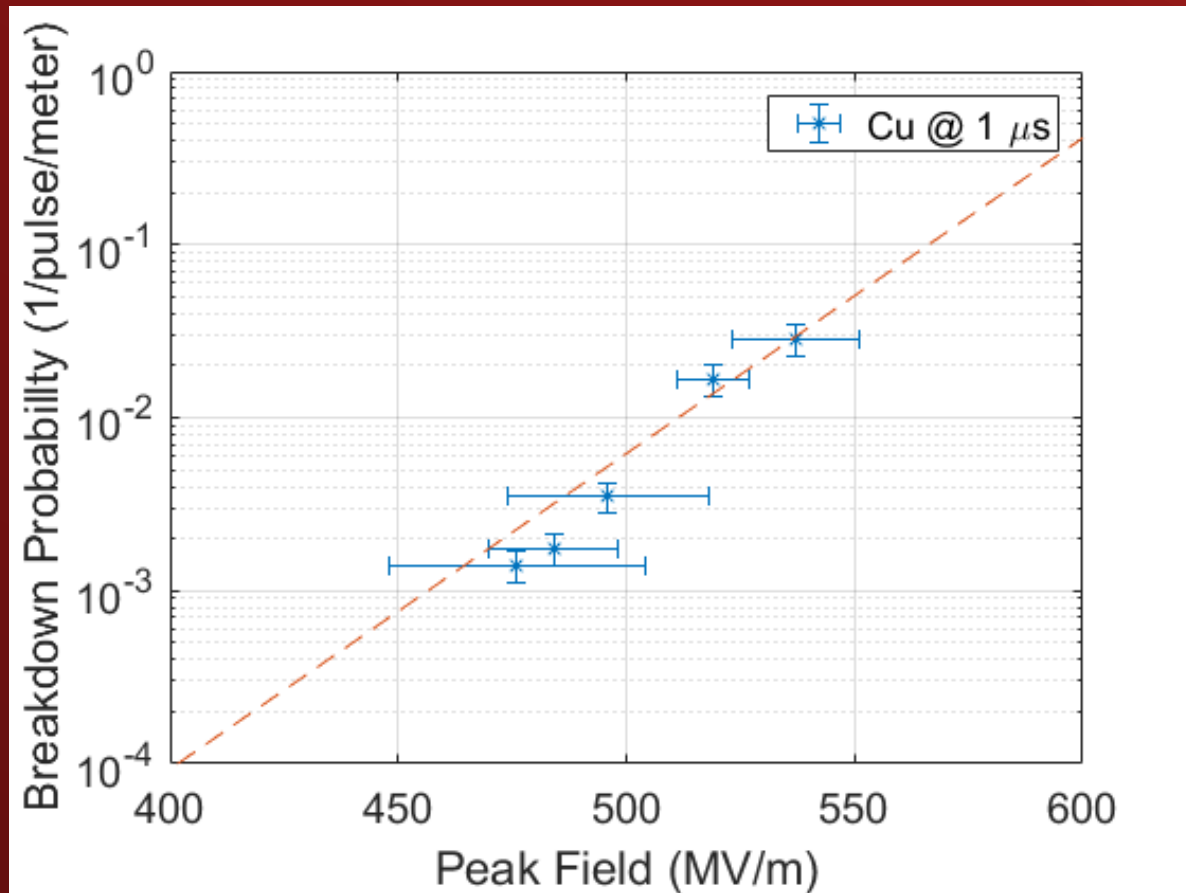

17. FC Fitting

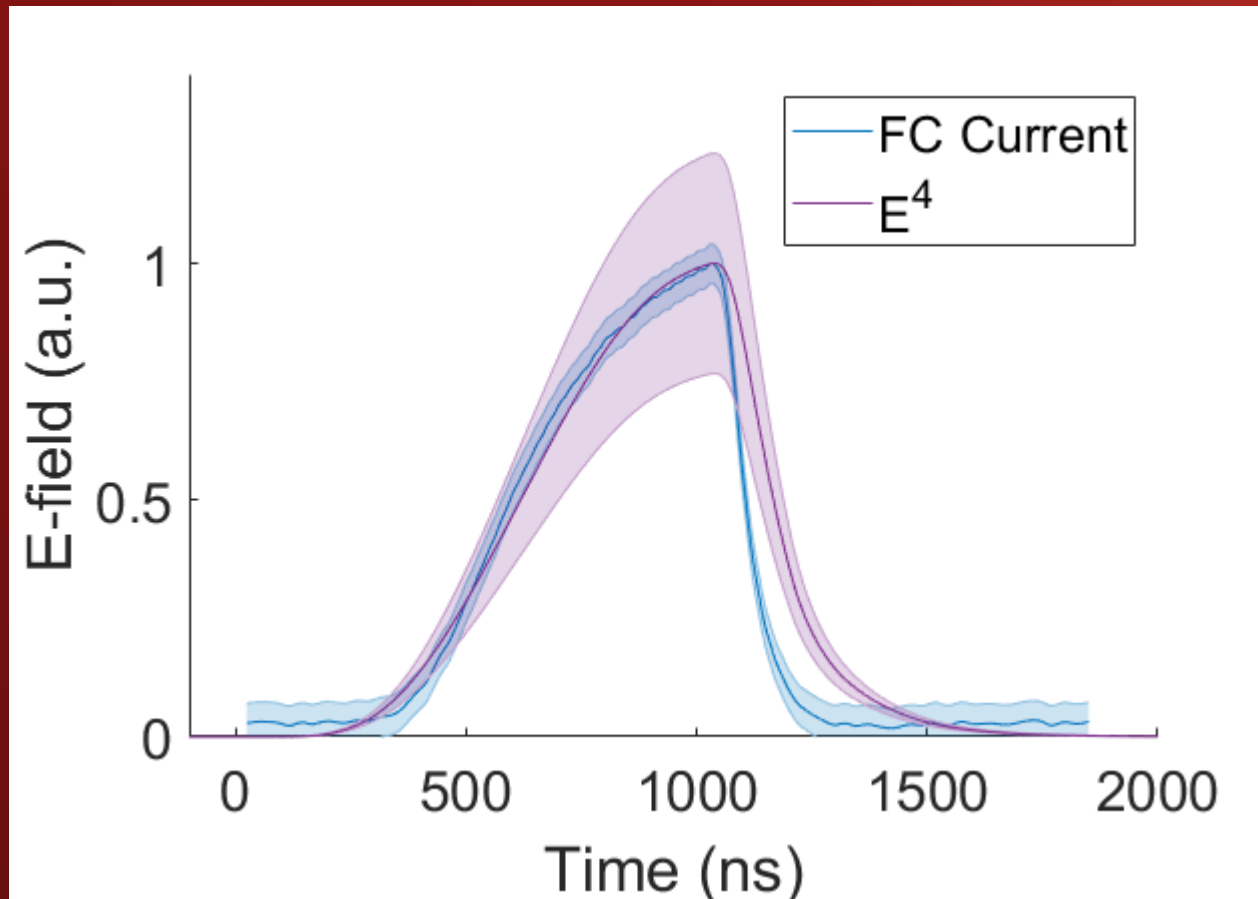

After calculating the $E_p(t)^n$ is proportional to the Faraday cup current both were normalized and scaled to find the power and to the power law

If field emission was the primary source of beam loading current should scale exponent to the 2.5

Scaling appears to decrease as power is increased from $n=4$ to $n=2.5$ at ultrahigh gradients and approaches pure field emission does this mean that the higher number exponents are due to not capturing the full breadth of the field emission current due to capture ratio?

17. FC Fitting

