



Field Dependence of Conditioning Part 1: *Electrode Simulation and Design*

Lee Millar¹, Walter Wuensch¹, Victoria Bjelland^{1,2}

¹CERN SY-RF-MKS

²Norwegian University of Science and Technology (NTNU)



11th International Workshop on the Mechanisms of Vacuum Arcs (MeVArc 2024)

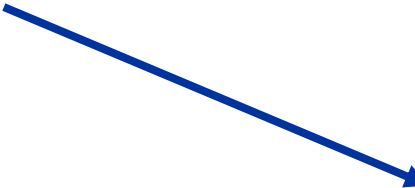

A Short Notice...

As the name suggests, this talk is a two-parter. I will attempt to set the stage by providing the motivation for this study; Victoria will then present a comprehensive overview of the test results.

But that's not all, see [Yinon's talk](#) for some post-test measurements!



Signs of plastic response in surfaces exposed to high electric fields.   

 Mar 6, 2024, 2:00 PM  30m

Speaker

 Yinon Ashkenazy (The Hebrew Univers...

Oral Experiments and Di... Experiments and Diagn...

Contents

- 1. Overview of Our Conditioning Model.**
2. The Field Dependence Question(s).
3. An Electrode Answer.

Why is Conditioning Important?

Conditioning is commonplace (and necessary) in a variety of devices. Despite this, the breakdown and conditioning phenomena are not fully understood.

The Theoretical Motivation:

- If we can better understand how the electrode evolves (how/why the breakdown rate develops), we might consolidate existing theories and gain insight about the phenomena.

The Practical Motivation:

- Conditioning requires time and electricity (expense) and comes with a risk of component damage. A better understanding facilitates optimisation of the procedure and risk reduction. To give one example, CERN's high-gradient structures typically run 24/7 for several months before reaching the desired field level, pulse length, and breakdown rate.

High-Field Conditioning

To date, a wealth of conditioning data has been collected, and many attempts have been made to connect theory to the measurements.

However, **conditioning is dynamic; the BDR evolves during measurements.**

Additionally, we have data for a variety of devices, many of which were conditioned differently.

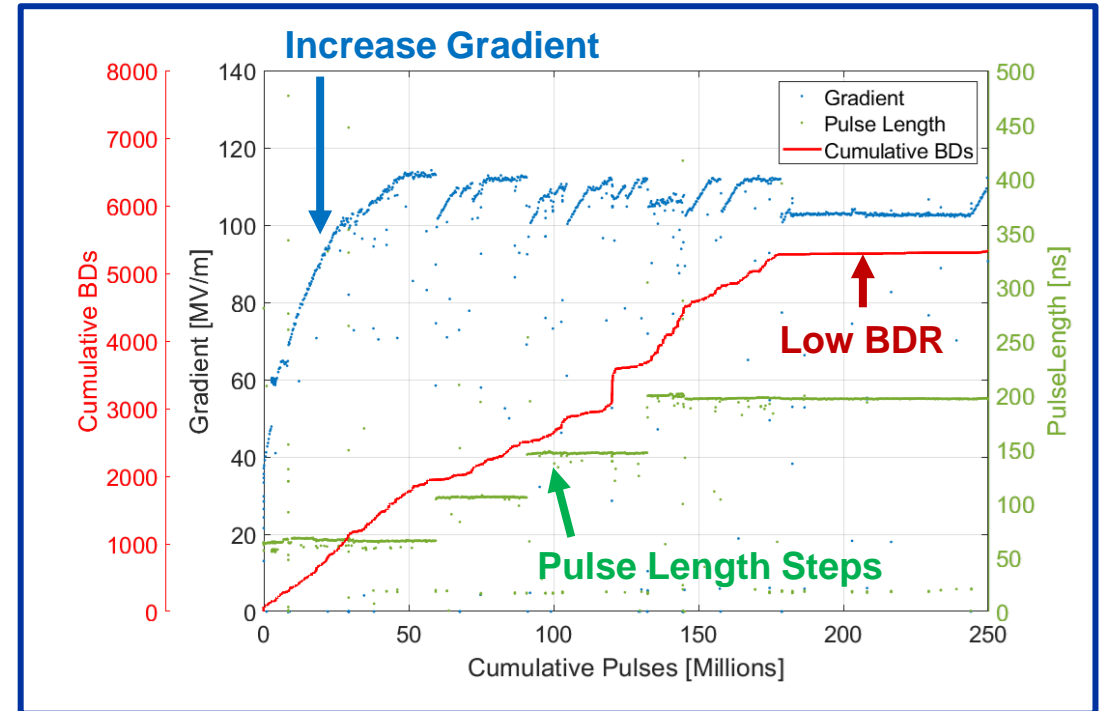

Figure: Typical conditioning procedure for a CERN accelerator cavity.

High-Field Conditioning

For reference, a few typical numbers for the RF cavities for the CLIC (Compact Linear Collider) study:

Peak surface fields $\approx 220\text{MV/m}$

Peak input power: $\approx 40\text{ MW}$.

RF Pulse length: $\approx 200\text{ ns}$ (8 Joules per pulse).

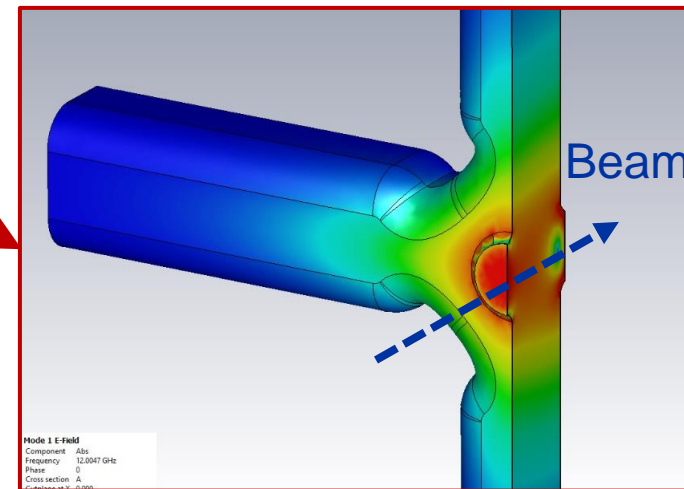
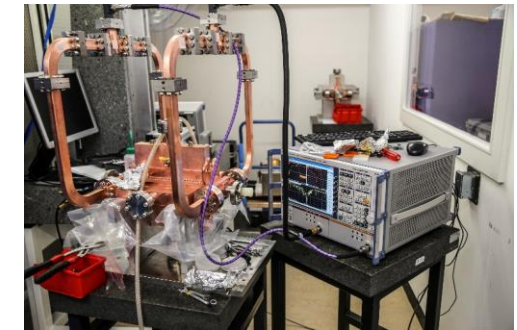

Figures: Precision machined disc (top left), a VNA measurement of an assembled accelerating structure (top right), E-field distribution in a single cell (bottom left). And discs being stacked and aligned prior to bonding (bottom right).

Overview of the Model

To help consolidate the experimental data, and trial our ideas, a simulation tool to model conditioning was developed at CERN.

In short, we assume that conditioning is not solely due to breakdowns, but a consequence of the applied field.

In other words, we also condition on pulses.

MONTE CARLO MODEL OF HIGH-VOLTAGE CONDITIONING AND OPERATION

W. L. Millar*, W. Wuensch, CERN, 1211 Geneva 23, Switzerland
G. Burt, Cockcroft Institute, Lancaster University, Lancaster LA1 4YW, UK

Based on these characteristics, the model assumes the experimental results and theory pertaining to field phenomena, a model has been developed for the conditioning and operation of high-field systems using a mesh-based method, the high-field conditioning of arbitrary geometry and surface electric field may be simulated for both RF and DC devices. The phenomena observed in previous high-field tests and the probabilistic behaviour of vacuum arcs and the local distribution of arc locations are described in each.

Based on these characteristics, the model assumes a maximum attainable electric field, E_L , for a given breakdown rate i.e. probability of arcing, P_R . The rate of conditioning of each element is denoted E_S , with a homogeneous field distribution, E_S then represents the surface electric field which can be established before breakdown rate. To provide the conditioning model assumes that, in the absence of breakdown, the conditioning rate is increased with each pulse as:

$$\Delta E_{S,i} = \gamma \cdot \frac{E_O \cdot k_i}{E_{S,i}} \cdot \left[1 - \frac{E_{S,i}}{E_L} \right]$$

INTRODUCTION

where γ is a constant to allow fitting to existing data in units of V/m . The letter term in Eq. (1) then represents

Figure: Snippet of the relevant [LINAC2022 conference paper \(MOPOR124\)](#) [1].

Overview of the Model

We employ a mesh, treating each element separately. We then rely on three main assumptions:

1. Each pulse improves (conditions) the surface elements → reduces probability of breakdown.
2. Elements asymptotically approach a limit, above which no improvement (further conditioning) takes place.
3. Breakdowns randomly worsen or improve a given surface element.

For details, please see the references, or come find me during the break!

Overview of the Model

Cavity simulation (cell-to-cell).

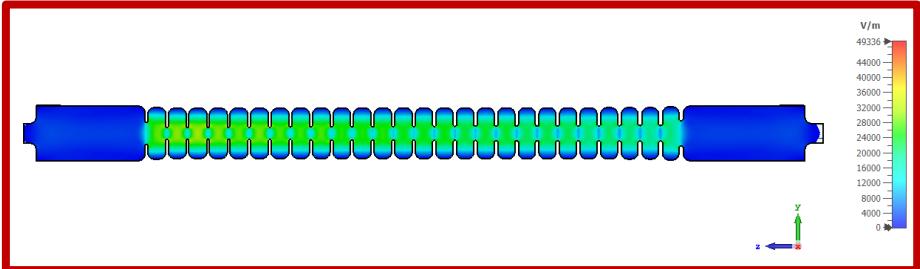

Spatially resolved single-cell simulation.

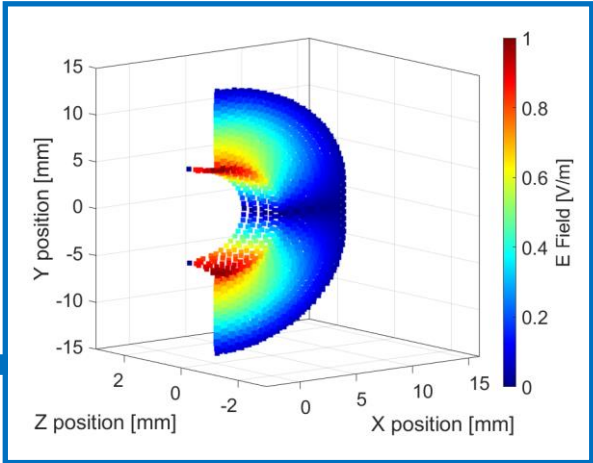

Overall, fits the data well!

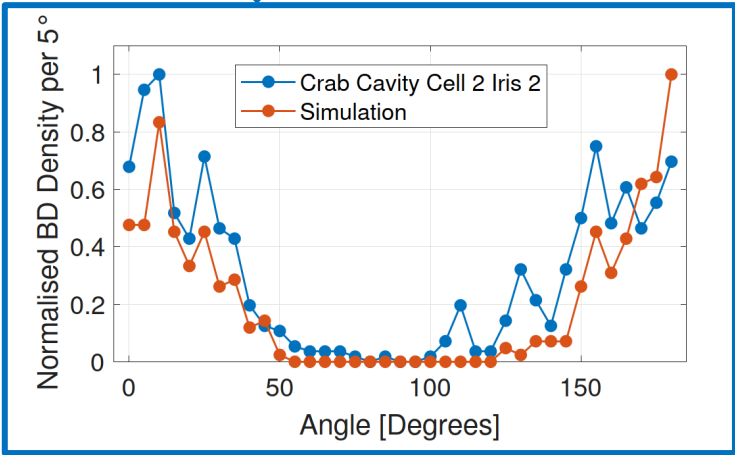
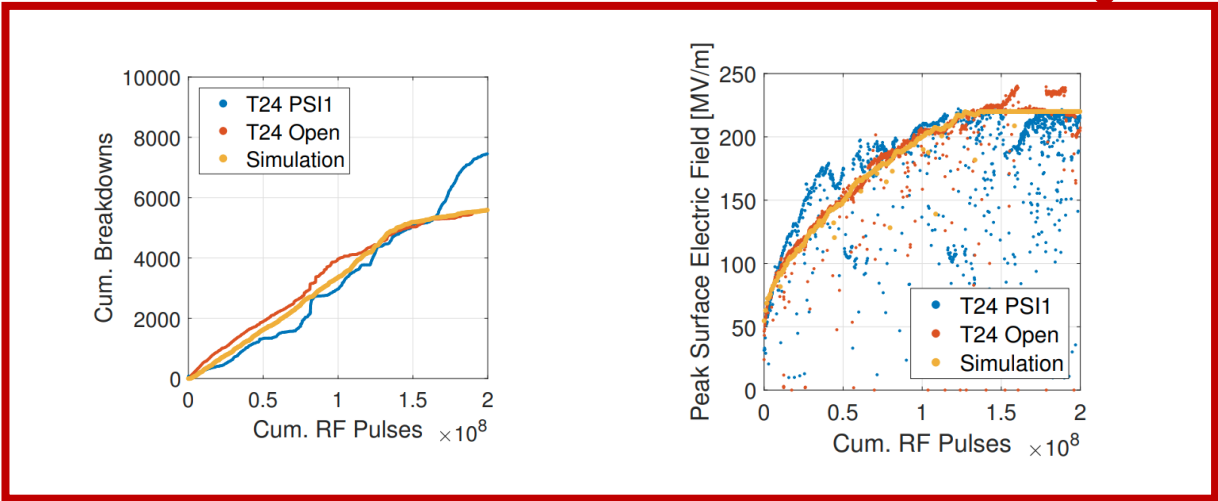

Contents

1. Overview of Our Conditioning Model.
- 2. The Field Dependence Question(s).**
3. An Electrode Answer.

Example: The CLIC Crab Cavity

Shown below is a constant impedance travelling wave RF cavity. In this multi-cell cavity, there is a gradual decay in the electromagnetic field from cell to cell.

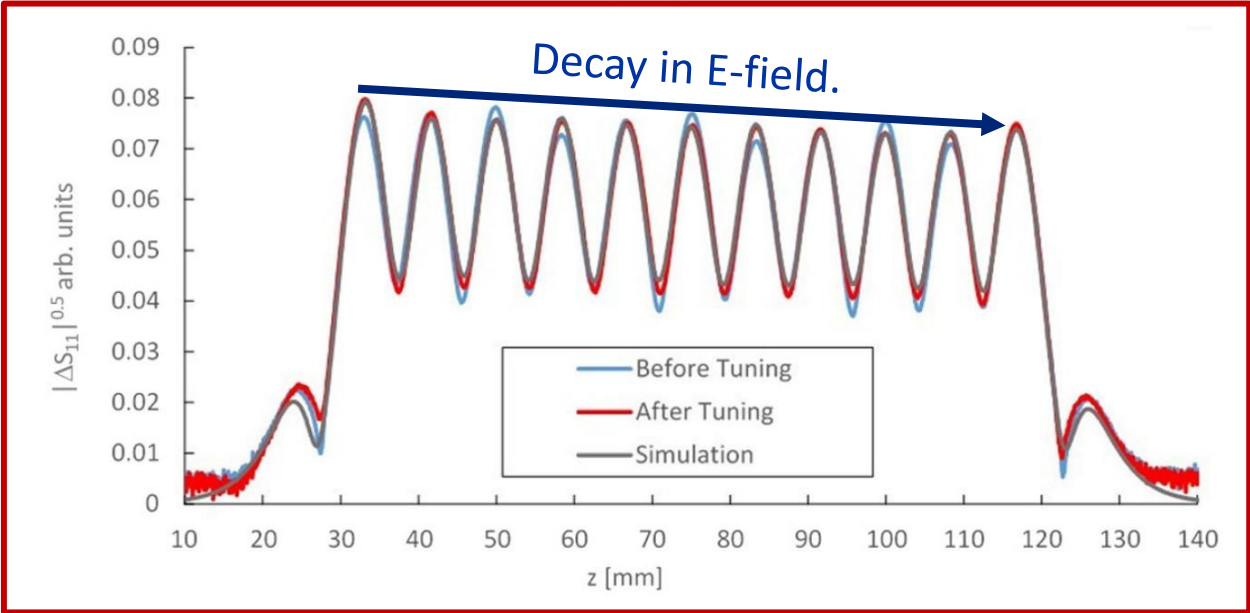
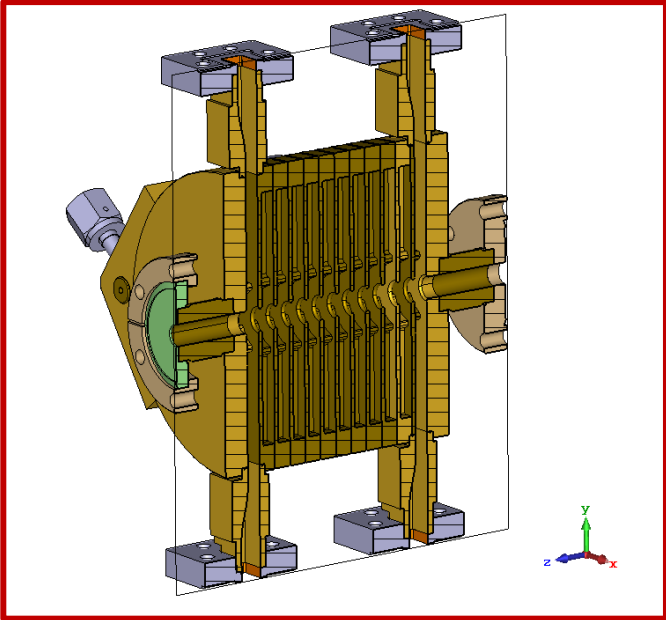

Example: The CLIC Crab Cavity

During the high-power tests, we accrued a different number of breakdowns in each cell. By localizing them, we can plot the conditioning of each cell separately.

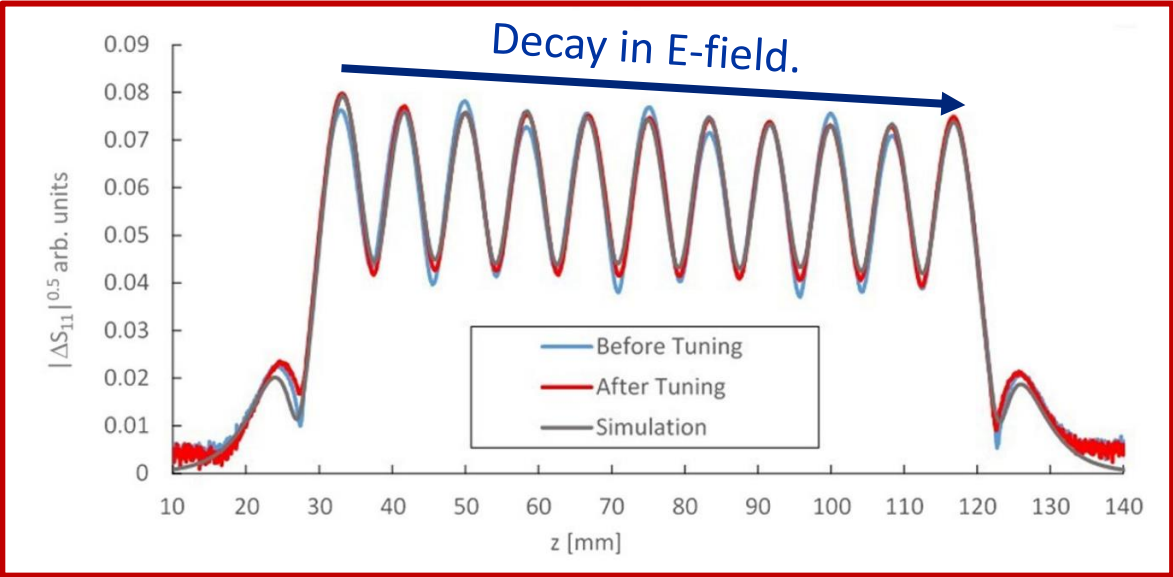

Figure: E-field profile on the beamline axis.

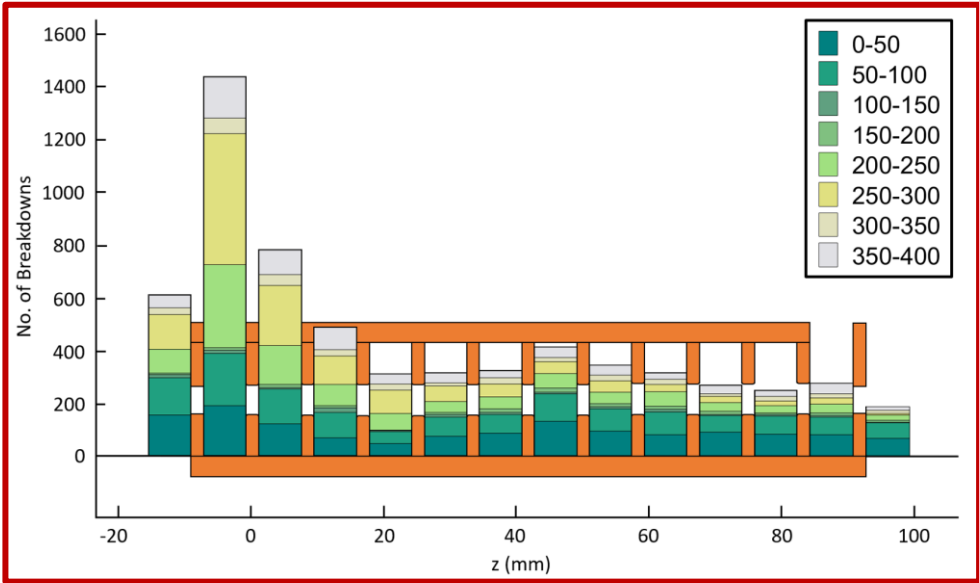

Figure: Number of breakdowns accrued in each cell for different windows of pulses (millions) during the test [2].

Example: The CLIC Crab Cavity

The difference between neighbouring cells is <1% in field. Hence, they were subjected to slightly different conditioning procedures. Notably, they all reach a given field while accruing a different numbers of breakdowns.

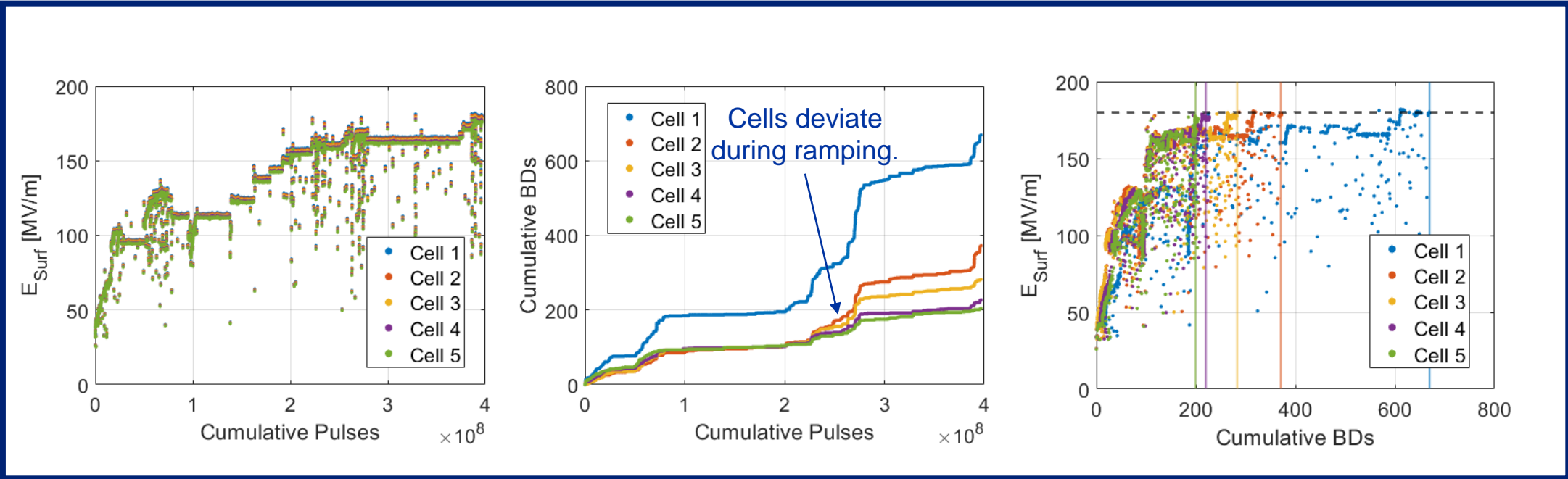

Figure: Conditioning curves for the first five cells of the CLIC crab cavity.

Example: The CLIC Crab Cavity

This points to a clear “field dependence” on conditioning. Using the same cavity, I’ll now show a more visual example.

Example: The CLIC Crab Cavity

Cavity after high-power test and cutting.

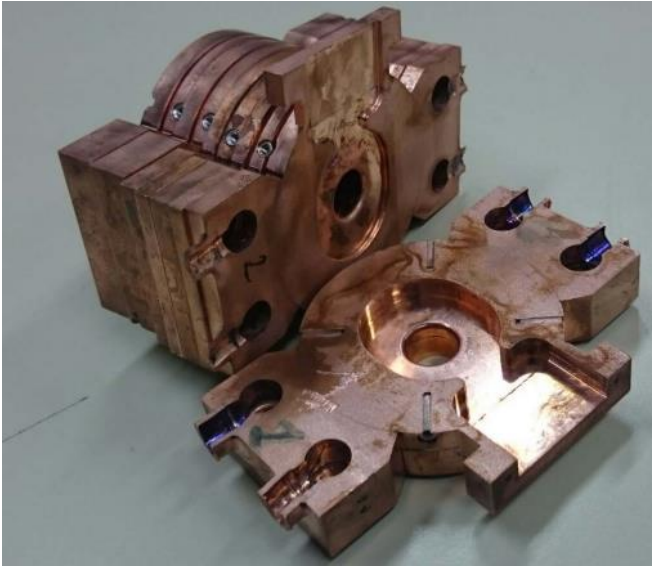

Face of a single cell.



Breakdown locations superimposed on electric field distribution.

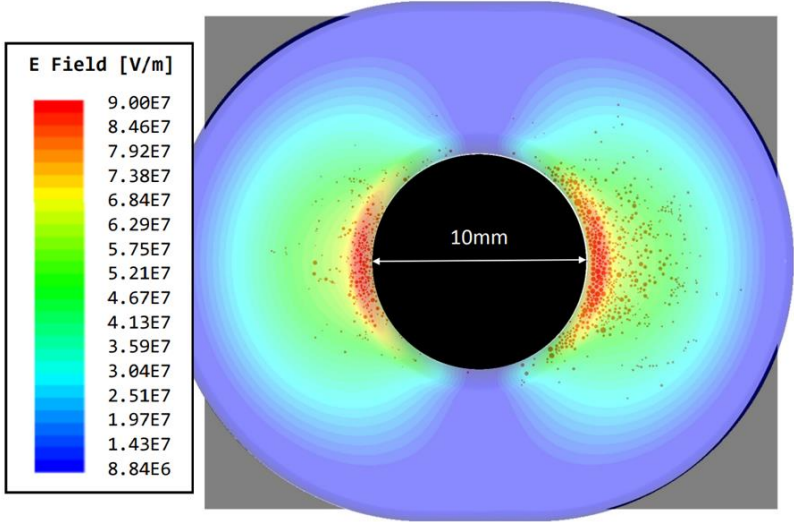
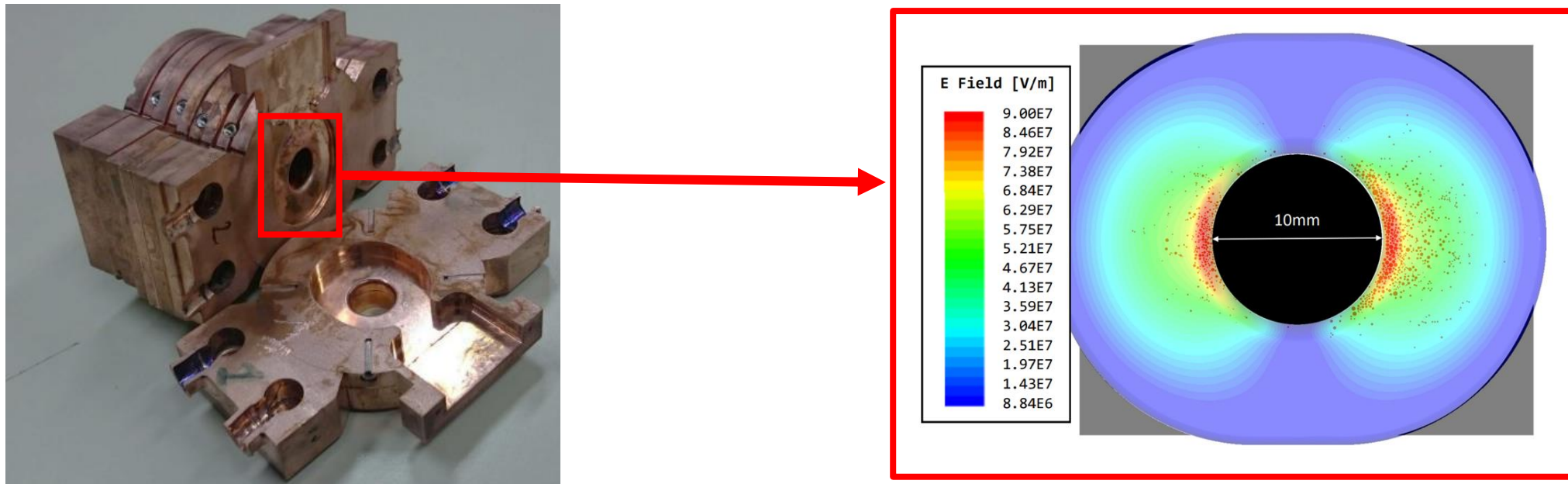

Figure: Images from the post-mortem examination of the CLIC crab cavity [3].

Example: The CLIC Crab Cavity

During tests, the global BDR usually scales strongly with the applied field ($\sim E^{10-30}$) but the local BDR rate scales differently (as is visible with the RF cavity below).



Figures: The CLIC crab cavity after testing (left) and the breakdown positions overlaid on the surface electric field distribution (right).

Example - The CLIC Crab Cavity

Real BD distribution.

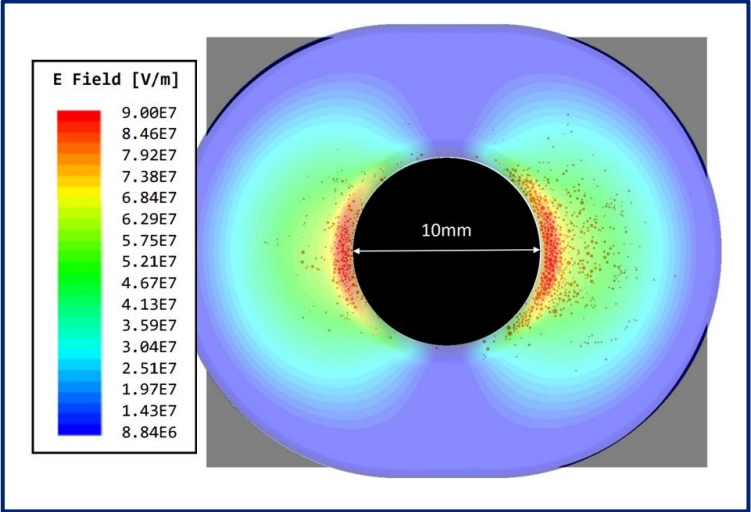

Simulated BD distribution.

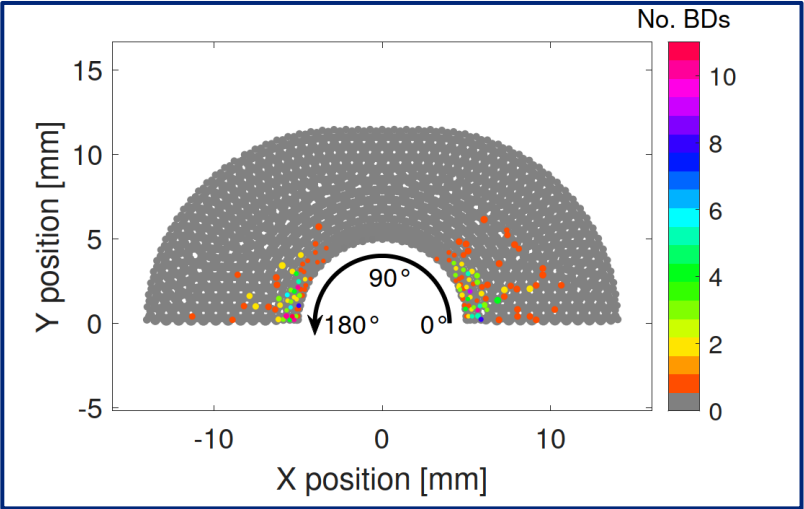

Comparison.

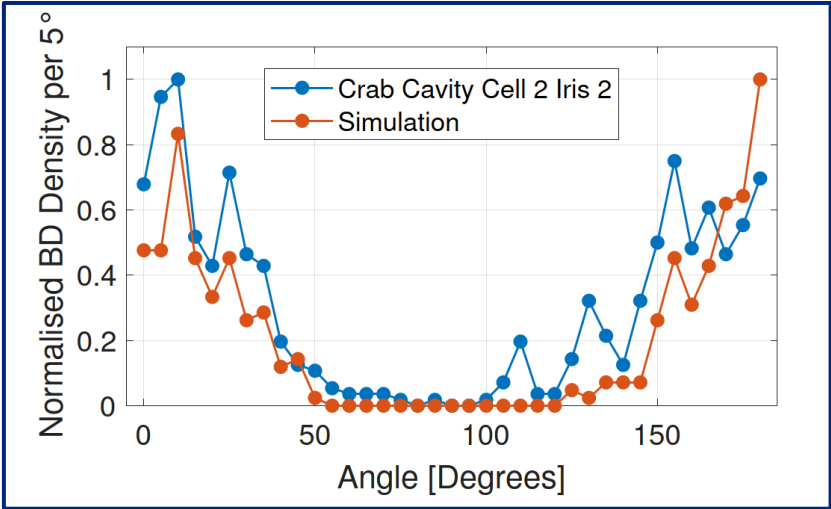

The Field Dependence Question

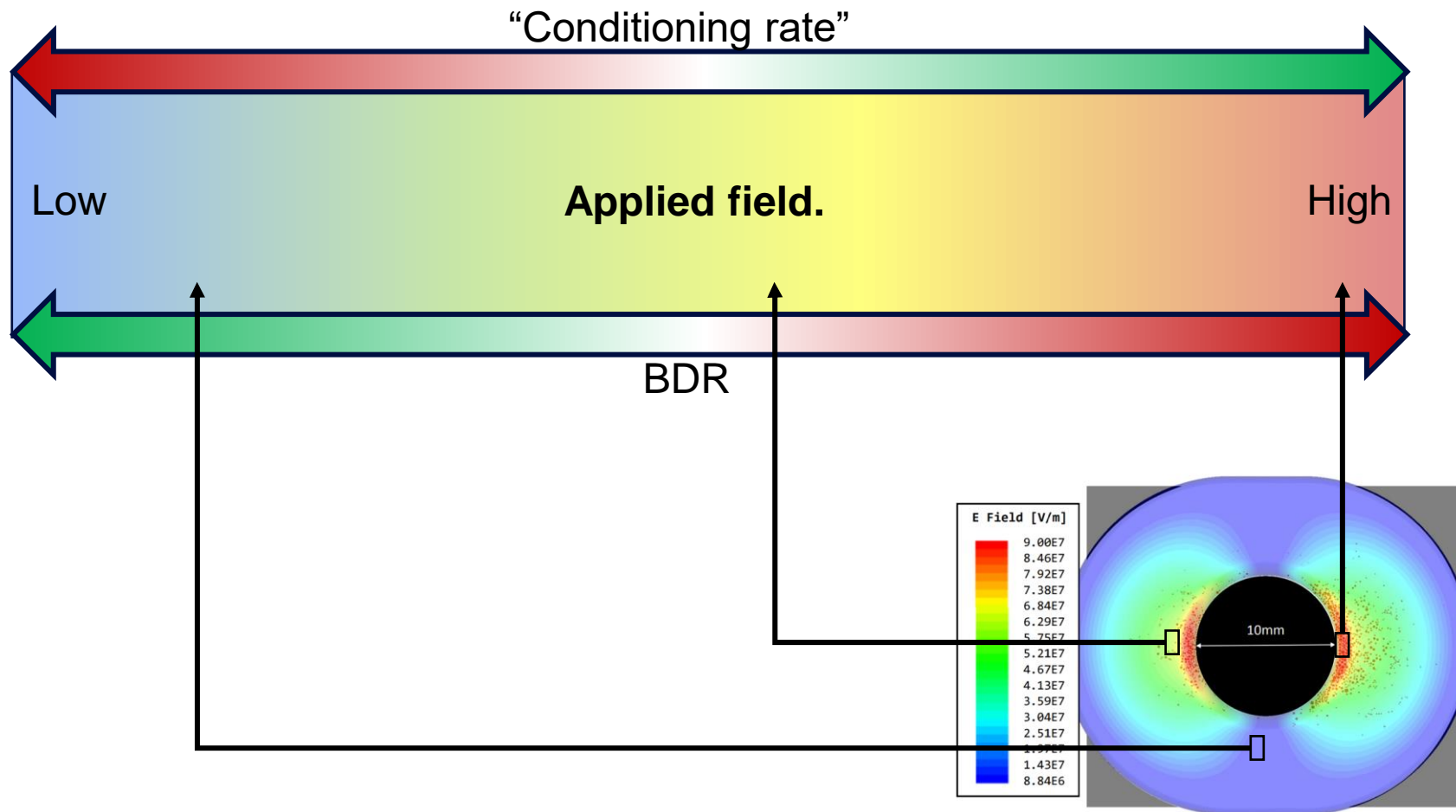

The Field Dependence Question

Again, this suggests a field dependence on conditioning, and points to several new questions:



- **To what extent are the breakdowns necessary?**
- **Can we regulate the field to prevent them and is there any benefit to doing so?**
- **By looking at different regions, can we relate the surface's propensity for high-field operation more concretely to a metallurgical quantity? If so, which one(s)?**





The Field Dependence Question

Again, this suggests a field dependence on conditioning, and points to several new questions:

- To what extent are the breakdowns necessary?
- Can we regulate the field to prevent them and is there any benefit to doing so?
- **By looking at different regions, can we relate the surface's propensity for high-field operation more concretely to a metallurgical quantity? If so, which one(s)?**



Signs of plastic response in surfaces exposed to high electric fields.   

 Mar 6, 2024, 2:00 PM  Oral  Experiments and Di...  Experiments and Diagn...

Speaker

 Yinon Ashkenazy (The Hebrew Univers...

Contents

1. Overview of Our Conditioning Model.
2. The Field Dependence Question(s).
- 3. An Electrode Answer.**

Simulation and Design

Given its simplicity and comparatively low cost (relative to the RF test stands), the LES (Large Electrode System) is an attractive means of investigating this phenomenon.

However, only flat, uniform electrodes have been studied so far (E-field is relatively homogeneous)...

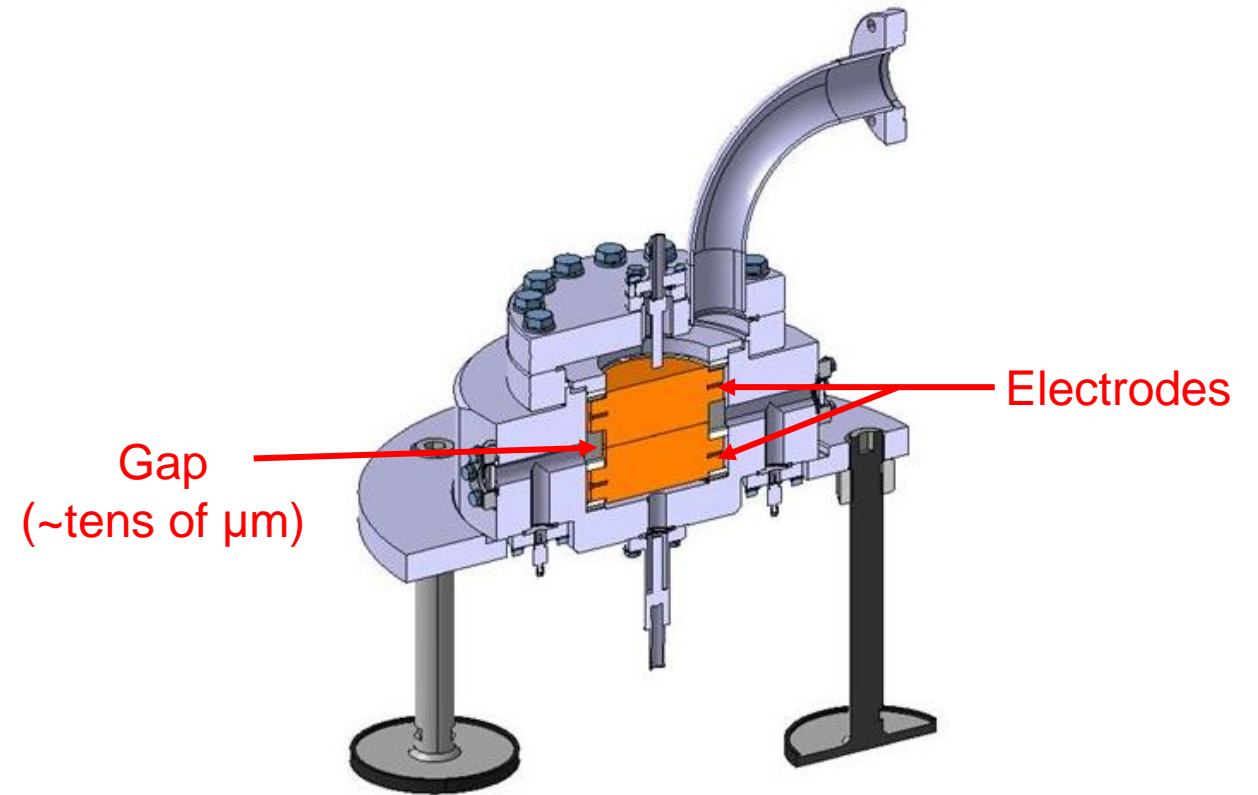
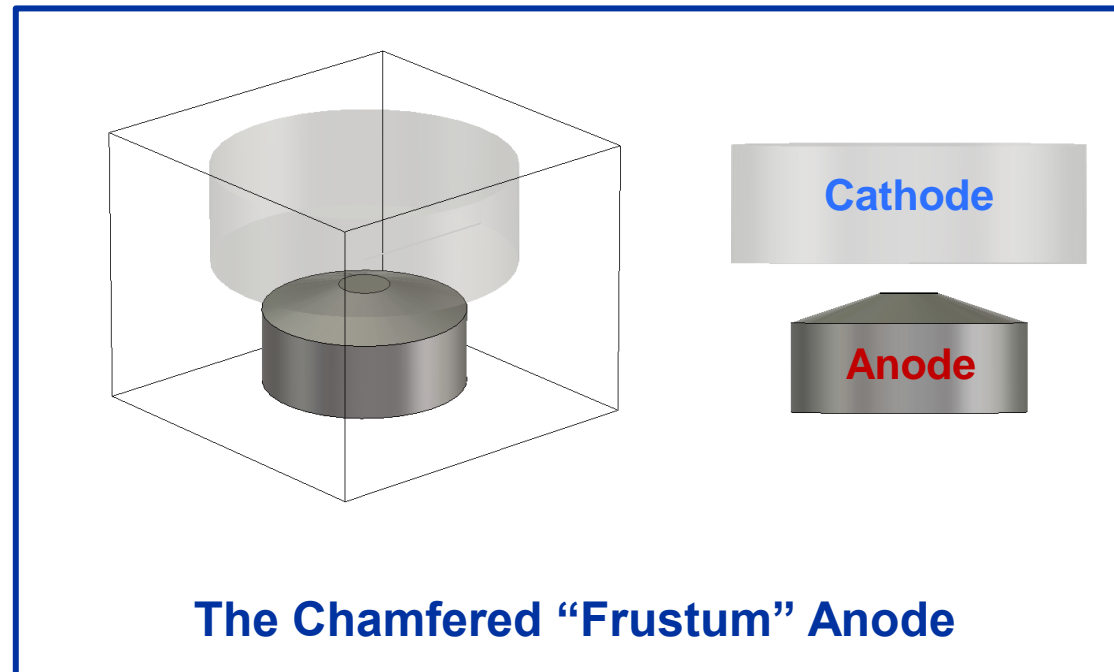

Figure: Rendering of CERN's LES [4].

Simulation and Design

Enter the frustum electrode – an electrode with a very gradual chamfer (~tens of microns).



For illustrative purposes only, dimensions exaggerated!

Simulation and Design

- Concentric sections are subjected to different conditioning procedures (ramping rate and BDR) – It's like multiple tests in one!
- By monitoring the evolution of the breakdown distribution in real-time (via cameras), we can more directly observe the field dependence of conditioning.

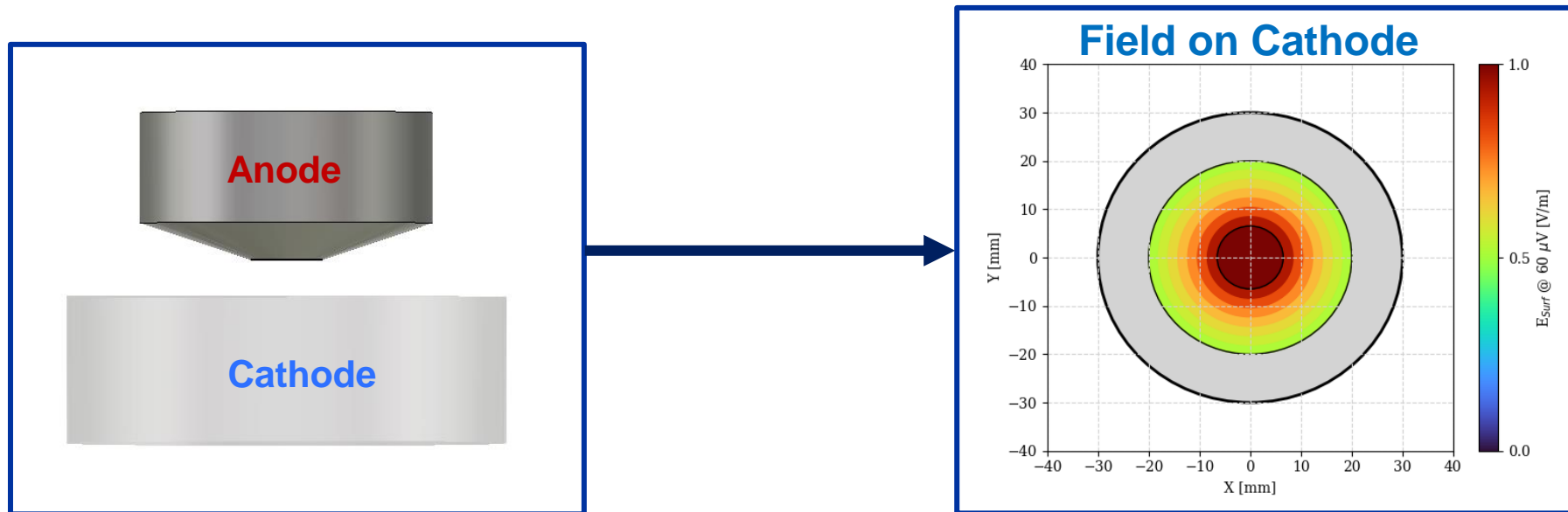

Simulation and Design

The electrode was roughly optimised in simulation using our conditioning model. The target – a decay in the density of the BD distribution (a lot of activity in the centre, less at the edge).

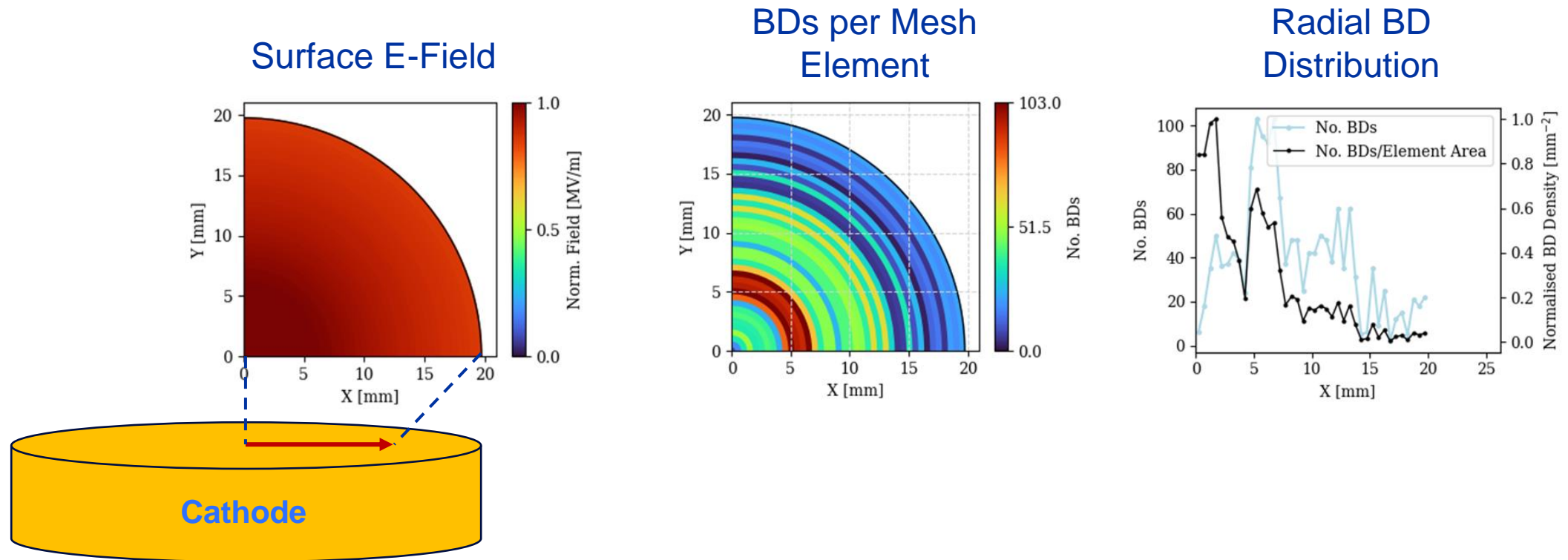

The “Frustum” Electrode

From simulation, two designs were selected:

Design 1 (gentle)

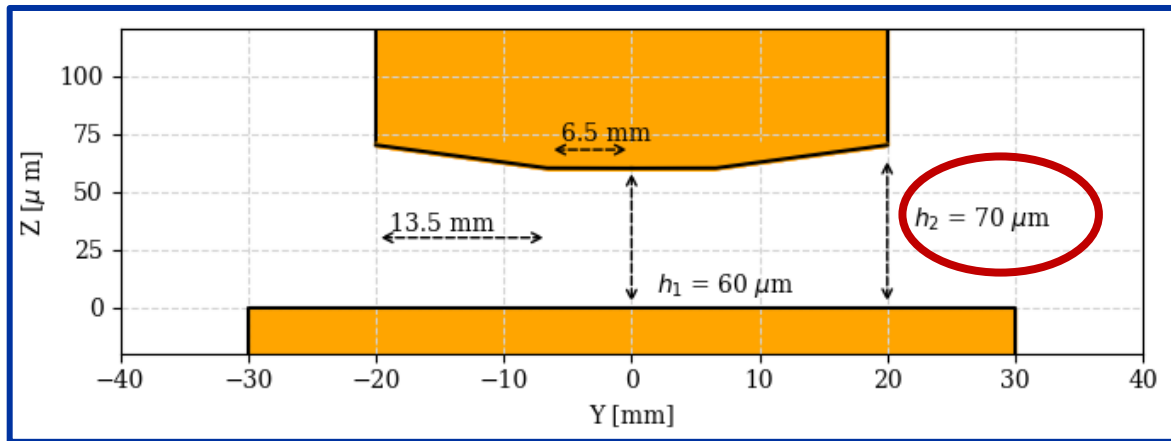

E-field reduction of ~14% (slope of only 10 μm !).

Design 2 (steep)

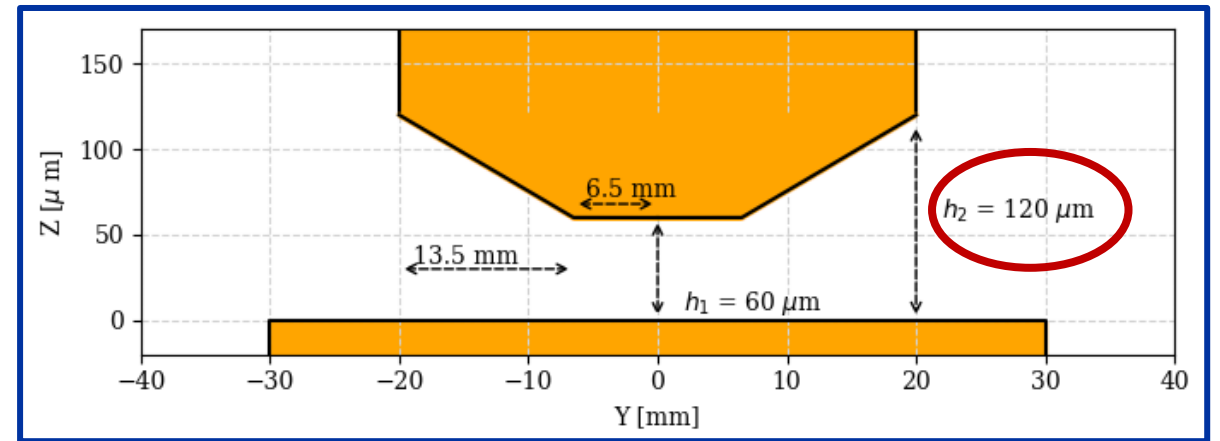

E-field reduction of ~50% (slope of 60 μm !).

Predicted Breakdown Distributions

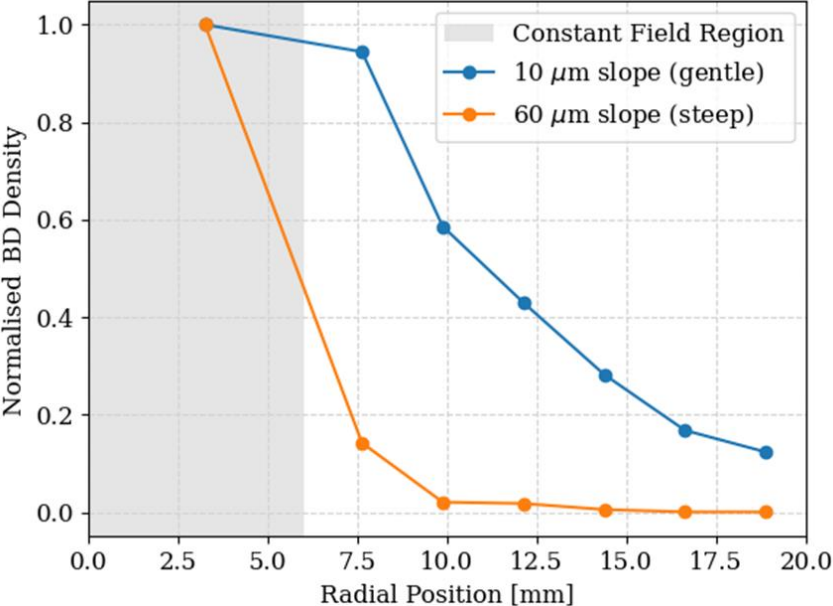
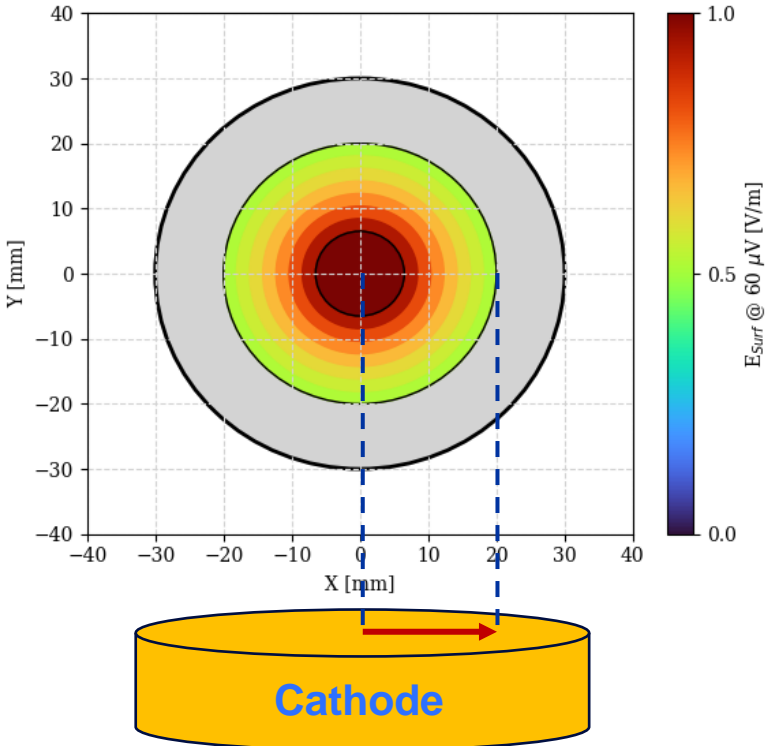

Note: Results shown are an average of 10 simulations (conditioned to 80 MV/m, ~3-400 breakdowns/sim).

Thank you. Questions?

References

- [1] – W. Millar et al., “Monte Carlo Model of High-Voltage Conditioning and Operation”, Proceedings of the 31st Linear Accelerator Conference (LINAC22), Liverpool, UK, 2022, pp.283-286, **DOI:** 10.18429/JACoW-LINAC2022-MOPORI24
- [2] – B. Woolley et al., “High-gradient behavior of a dipole-mode rf structure”, Phys. Rev. Accel. Beams 23, 122002, **DOI:** 10.1103/PhysRevAccelBeams.23.122002
- [3] – E. Castro, “CLIC Crab Cavity Post-Mortem analysis” (presentation), Available online: <https://indico.cern.ch/event/449801/contributions/1945273/>
- [4] – A. Korsback, “CERN dc spark system capabilities” (presentation), Available online: <https://indico.cern.ch/event/336335/contributions/788991/>

Bonus Slide - Simulation Mesh

Two approaches were trialed:

1. Equal radial increments e.g. increase the circle radius by 1mm and calculate the band area.
2. Concentric bands of equal area.

To obtain a radial breakdown density in the first case, we divide the no. of breakdowns each element has accrued by its relative area.

Essentially, we obtain the expected BD density if one were to draw an outgoing radial line (shown right by purple arrows).

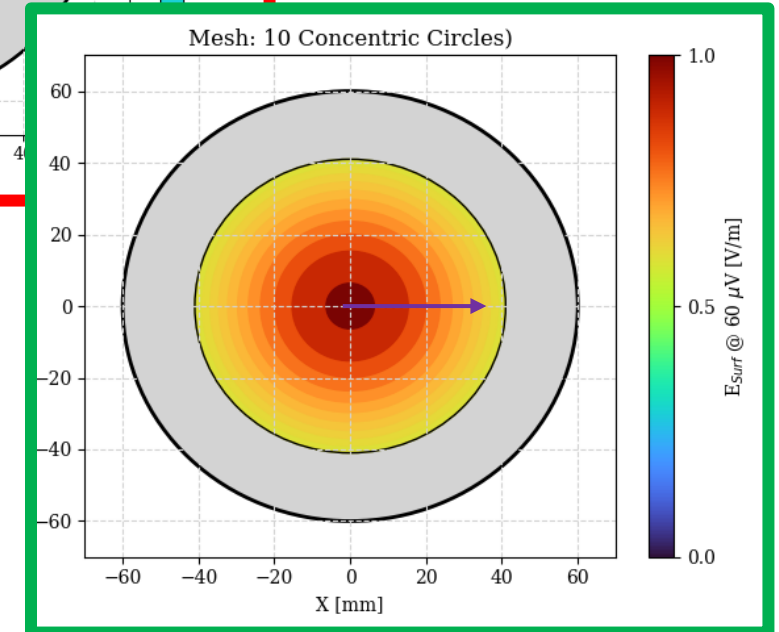
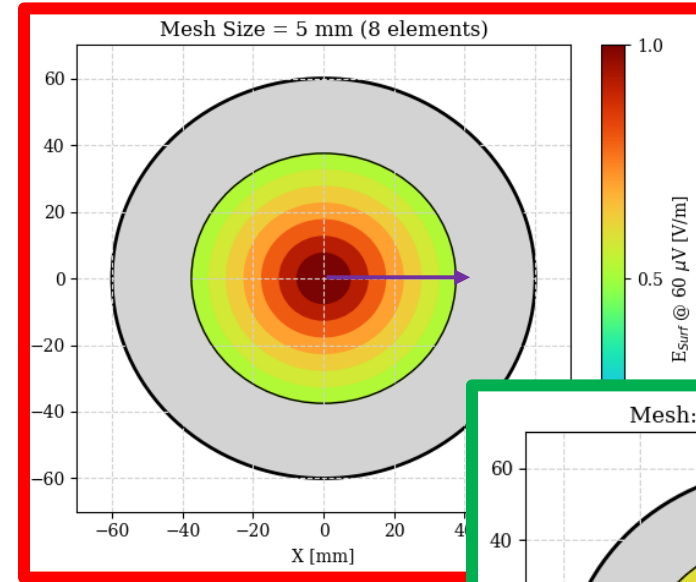

Bonus Slide - Simulated Conditioning Curve

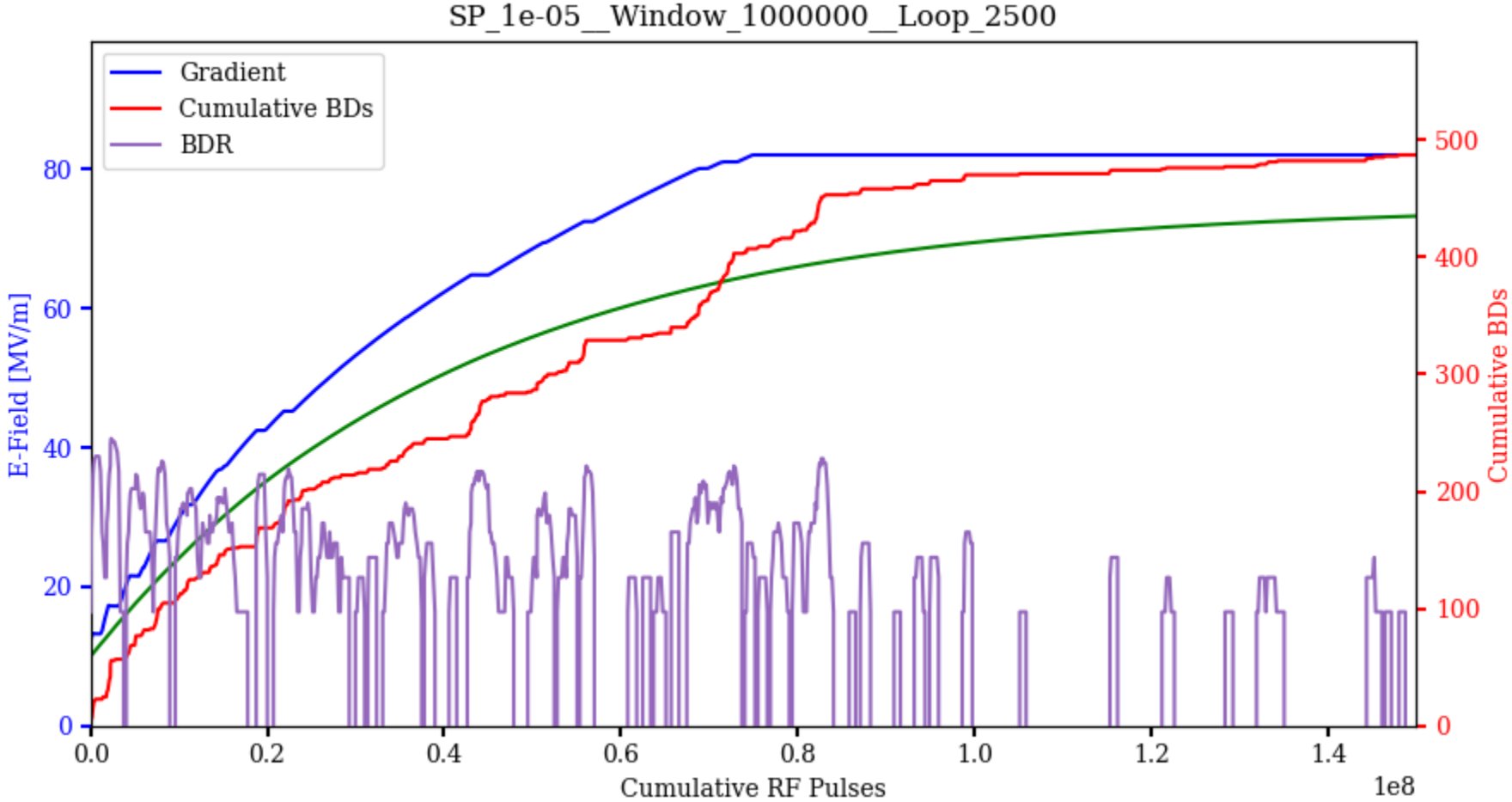

Bonus Slide - CLIC Crab Cavity Simulation

Experiment

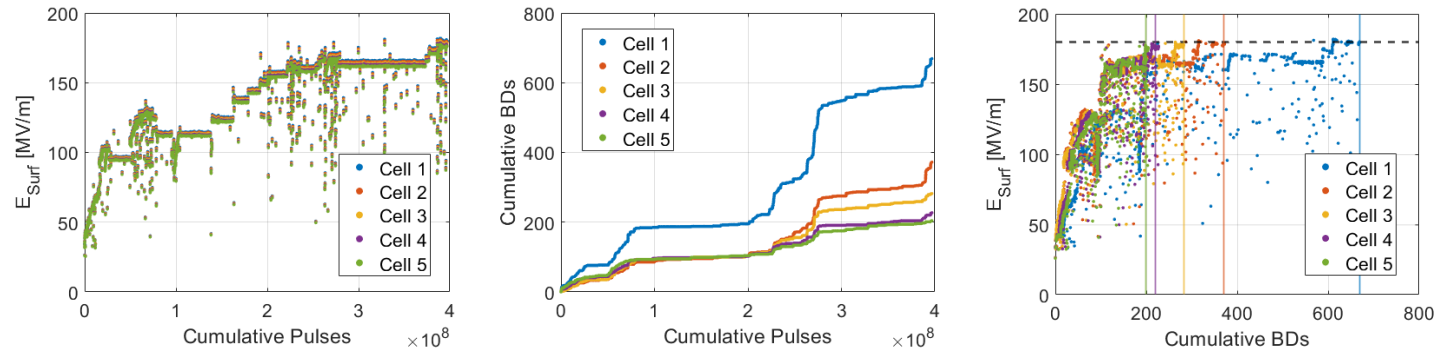

Simulation of the Effect

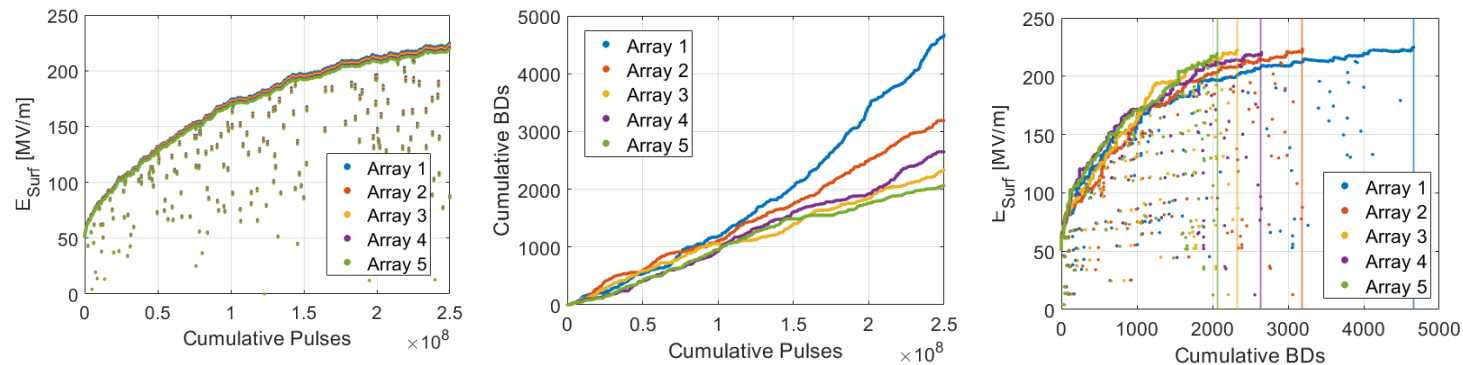



home.cern