

Exploring high gradient limit with cryogenic experiments at FREIA laboratory



M. Jacewicz, M. Coman, I. Profatilova, FREIA Laboratory, Uppsala University

W. Wuensch, S. Calatroni, CERN

I. Popov, Y. Ashkenazy, The Hebrew University of Jerusalem

Cryo DC pulsed system

- Focus on fundamental understanding of conditioning process and ultimate limit on accelerating gradient
- Search for optimum conditioning strategy → minimize the total number of breakdowns in the structure (without scarfing the required conditioning time)
- Help theoretical models of vacuum breakdown nucleation: strong dependence on temperature
- Behavior of different, NC and SC, materials, and thin-films
- Interest in cryogenic copper applications

Field emission and BDR as a function of temperature



Pressure : ~ 5×10^{-9} mbar (@cryo)

Temperature: flexible down to 4 K.

Electrodes (CERN std):
60 mm diameter cathode
40 mm diameter anode

Gap: 40 or 60 μm at warm,
(increasing **at cold**)

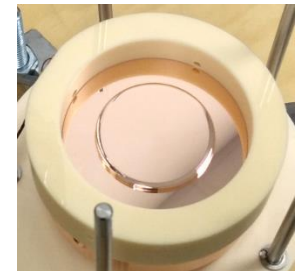
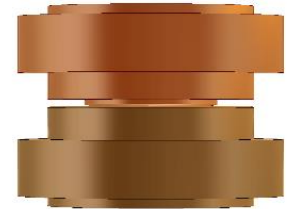

High voltage generator:

- Up to 12 kV voltage
- Pulsed DC
- Pulse width **1 μs** (up to 1 ms)
- Rep rate: **1 kHz** (up to 6 kHz)

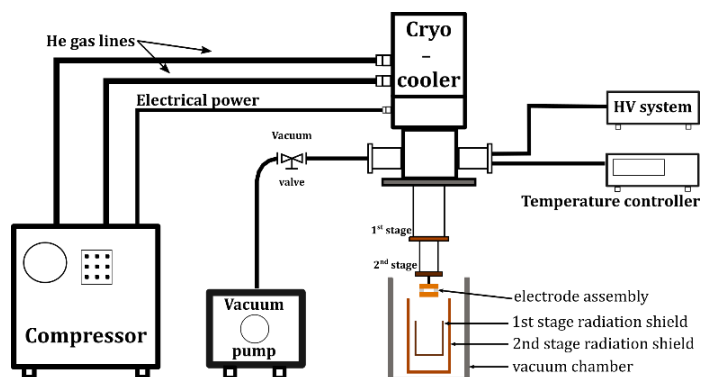

Results from cryo DC system

Outlook:

- Conditioning at different temperatures vs conditioning at single temperature,
- Different material: Cu vs Nb
- Cluster behavior

The results from cryo system are highly reproducible between the samples

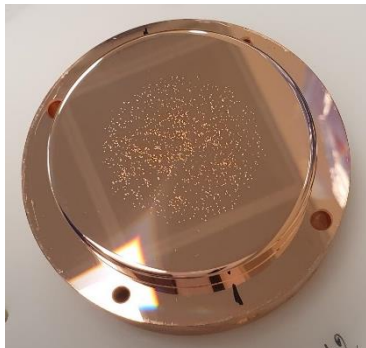
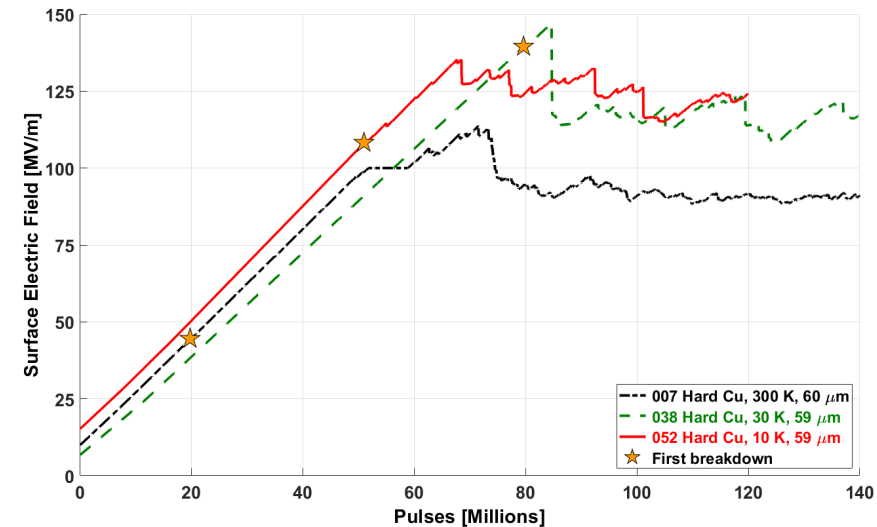
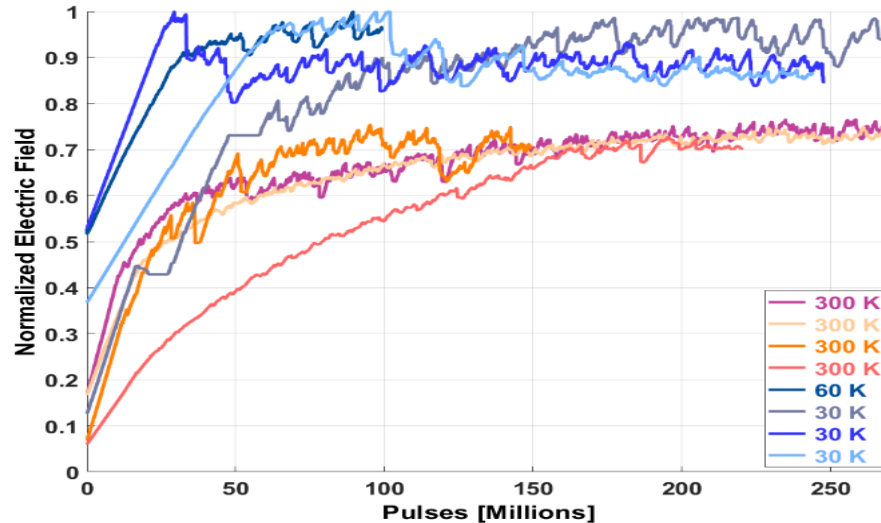

Temp	Gap size	First BD E_{field}	Max E_{field}	Saturated E_{field}	#BDs to max E_{field}
300 K	60 μm	46 MV/m	114 MV/m	90 MV/m	94
30 K	59 μm	140 MV/m	147 MV/m	120 MV/m	7
10 K	59 μm	108 MV/m	135 MV/m	123 MV/m	27

Surface morphology “post-mortem” HiRes optical scan with anode-cathode matching

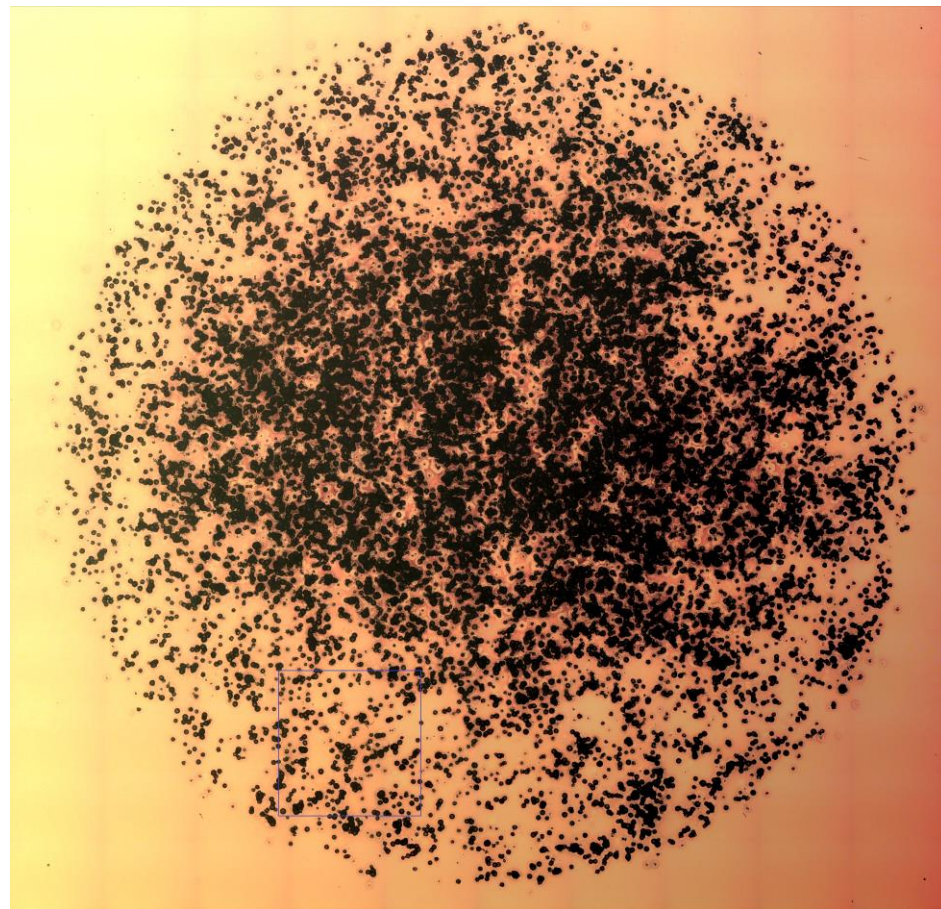

Surface morphology “post-mortem” HiRes optical scan with anode-cathode matching

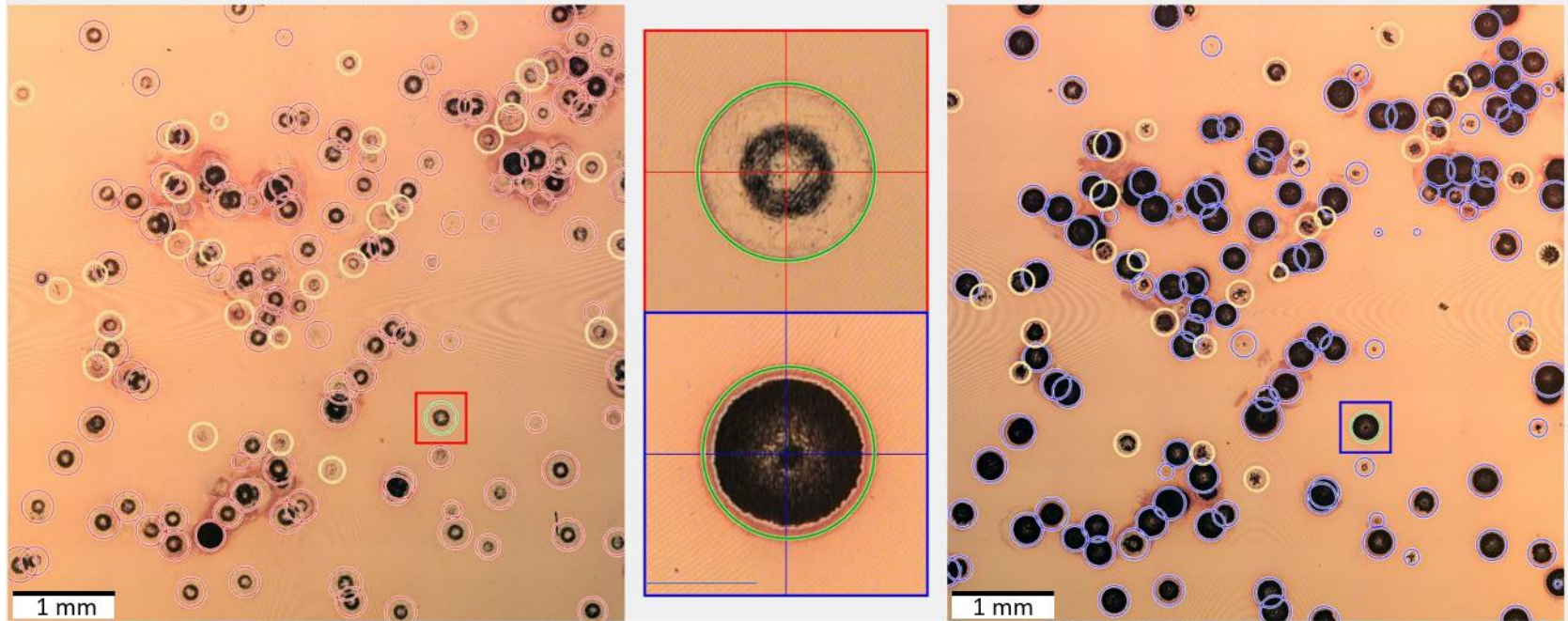

Atypical BD features cathode surface after high field conditioning at 30K and 10K

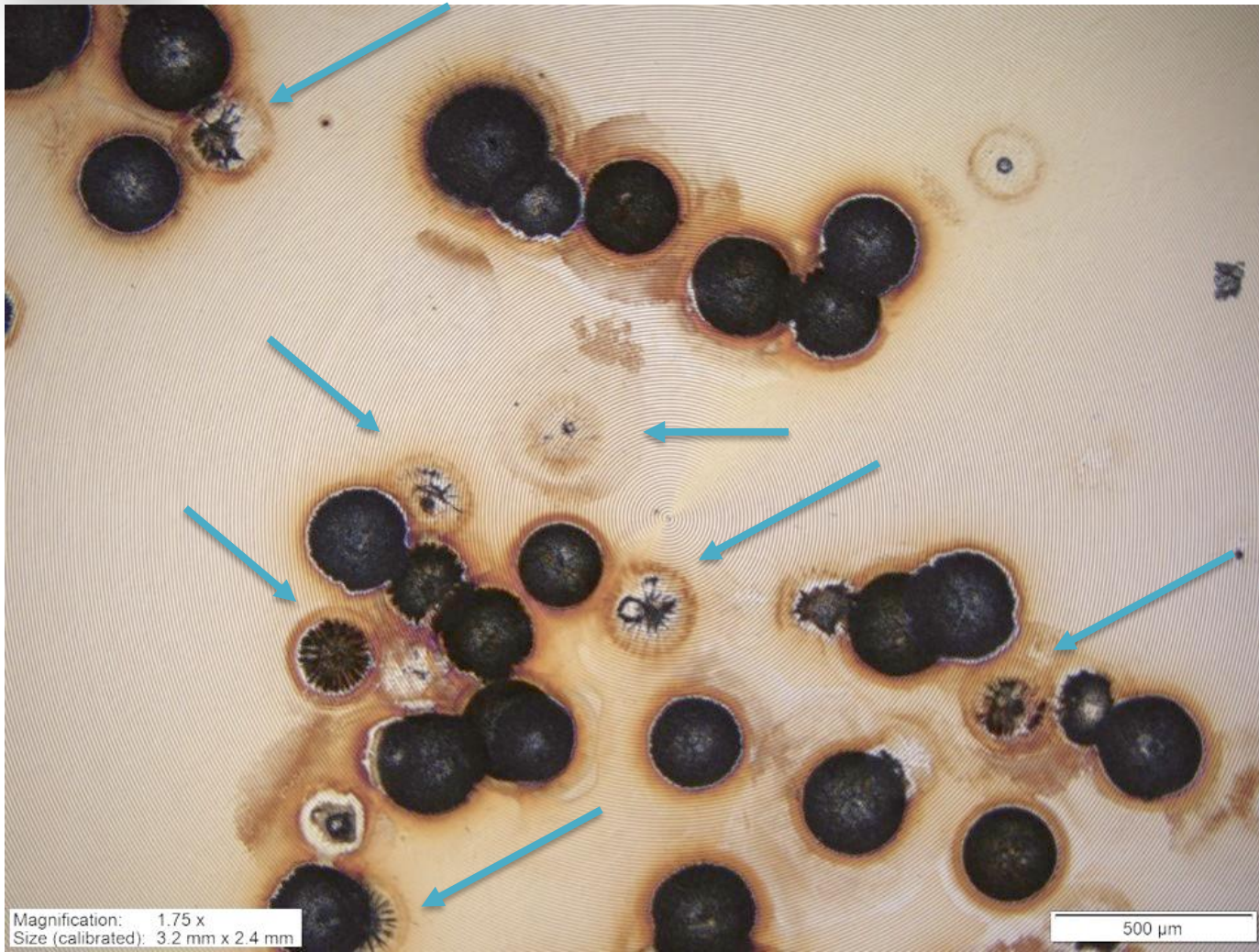

Star-like features created during cryo test

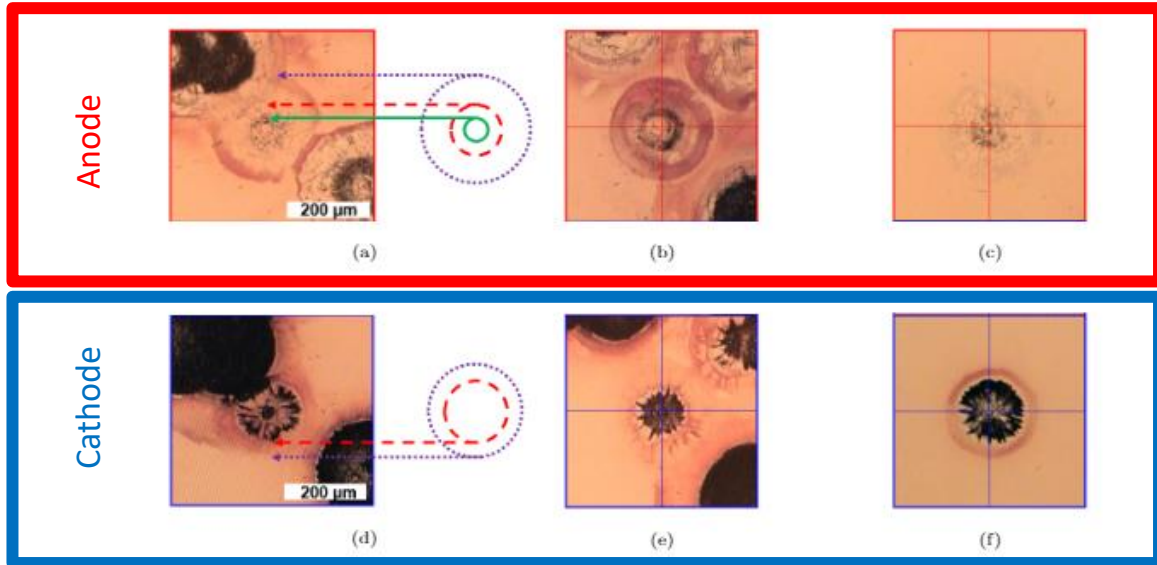
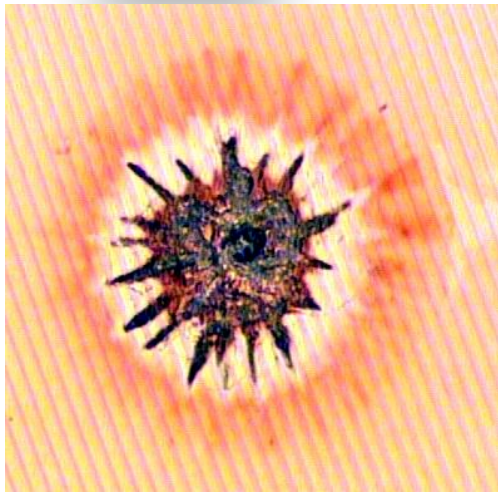

Temp	Nb of BDs	Nb of star-like	Fraction
30K	145	37	26±5%
10K	280	149	53±7%

Found only on cathode

Features on anode similar to regular ones, but "weaker"

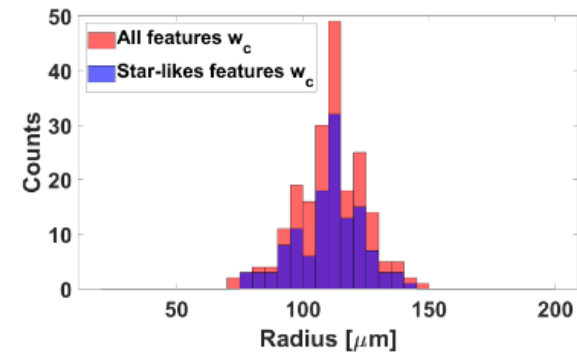
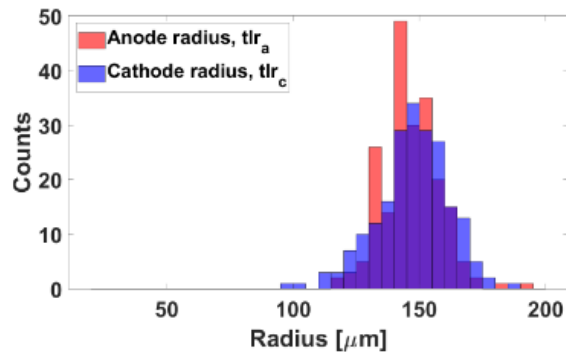
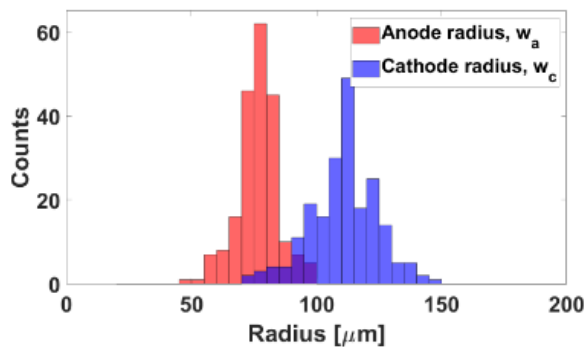

Temperature dependence

BD sites morphology show temperature dependence:

- Formation of star-like features and
- their percentage, doubling in number when going from 30K → 10K

Hypothesis:

- I. Ejection of molten material from unstable tip
 - II. Randomly lands on the cold(er) surface and freezes
 - III. When melting continues, the regular circle around the crater will form and expand → features created by plasma instabilities will be covered
- In the room temperature experiments we see therefore no star-like traces left
 - In cryo temperatures, the heat is dissipated more efficiently, and we can get a glimpse to the first stages of the thermal runaway of the tip

**We see a strong thermal effect also in FE scans
(see presentation by M. Coman)**

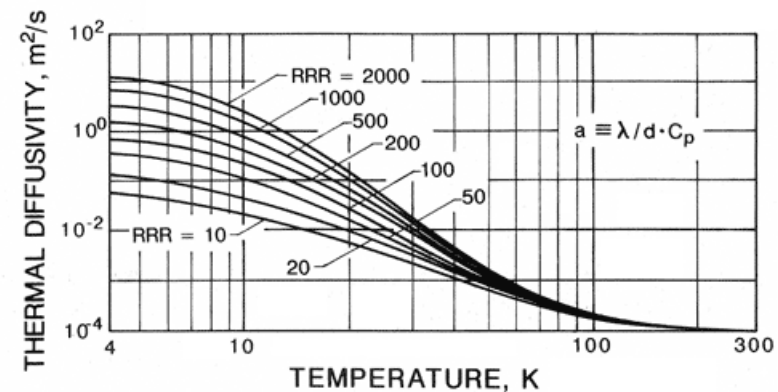

Difference in anode features

BD site – up to scale

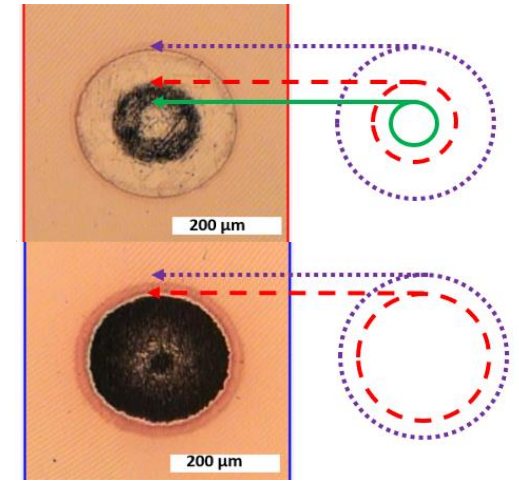

Cathode spots feature clear melting and reshaping of the surface

But looking at anode:

- The traces from machining are visible over anode's most inner lighter disk
→ no significant melting
- Dark wavy part covers or removes the grooves
- No radial jets around the anode BD feature (supports no-melting hypothesis)
- No significant differences between RT and cryo

So what can cause such a specific morphology of anode spots?
Why we do not see melting in the center



Understanding anode features

Working with short gap

E-beam radius on anode $\sim 20\text{-}30\mu\text{m}$
matches average radius of the central reflective disk

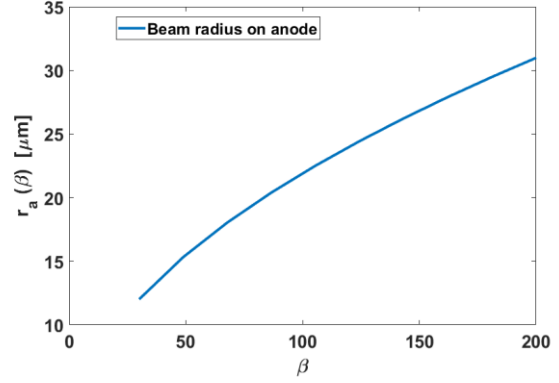
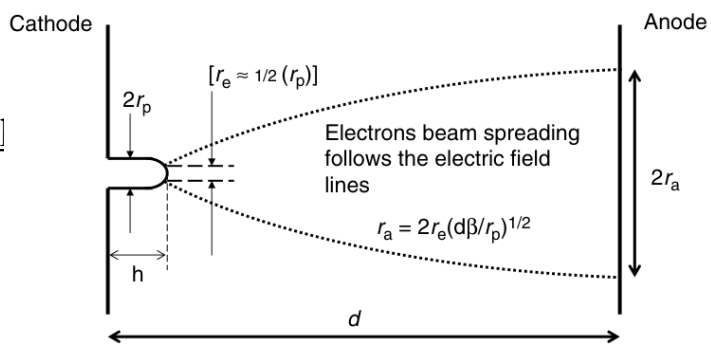

For $60\mu\text{m}$ gap the energy of electrons reaching anode is a few keV \rightarrow much higher probability of gas ionization for mm-size gaps

Cathode is important in the initialization of the BDs, but a more complicated mechanism is needed in the short gap system.

Hypothesis:

initial field emission current forms an electron beam that interacts with the emerging and expanding plasma and shields the central region from the melting and perhaps contributes to this unexpected anode features

Simulations needed!

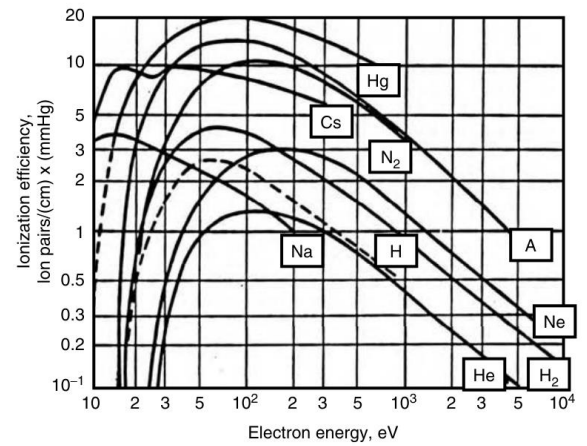

*) From.: Slade, P.G. (2020). The Vacuum Interrupter: Theory, Design, and Application (2nd ed.). CRC Press.

Samples were analyzed after field exposure to identify variations in their sub-surface structure. (e.g. STEM picture of cross-sectional lamellas)

see Yinon's presentation for details

“Signs of plastic response in surfaces exposed to high electric fields”.

RT sample 007-Cu

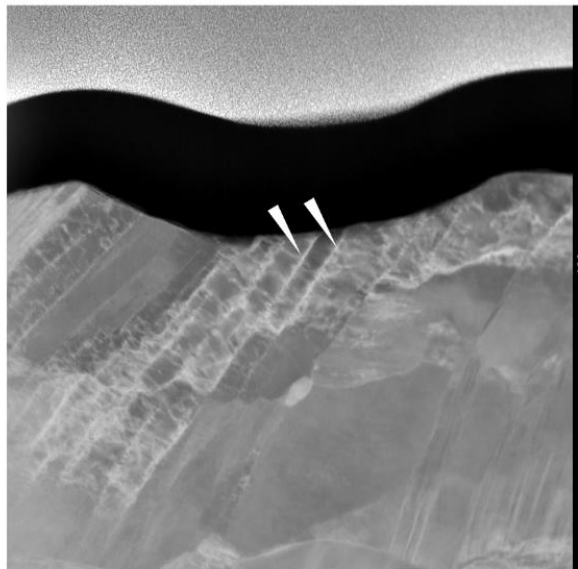

30K sample 038-Cu

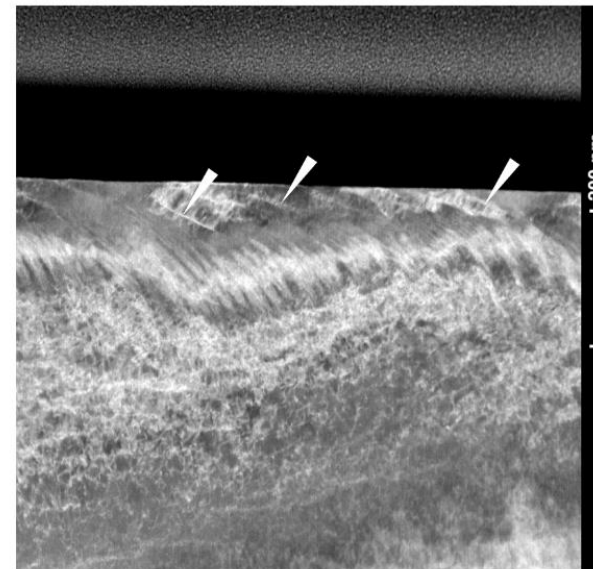



Niobium

Nb conditioning at 4K



Saturation field: 150 MV/m
Total #BDS: 3890
Gap: 66 μ m

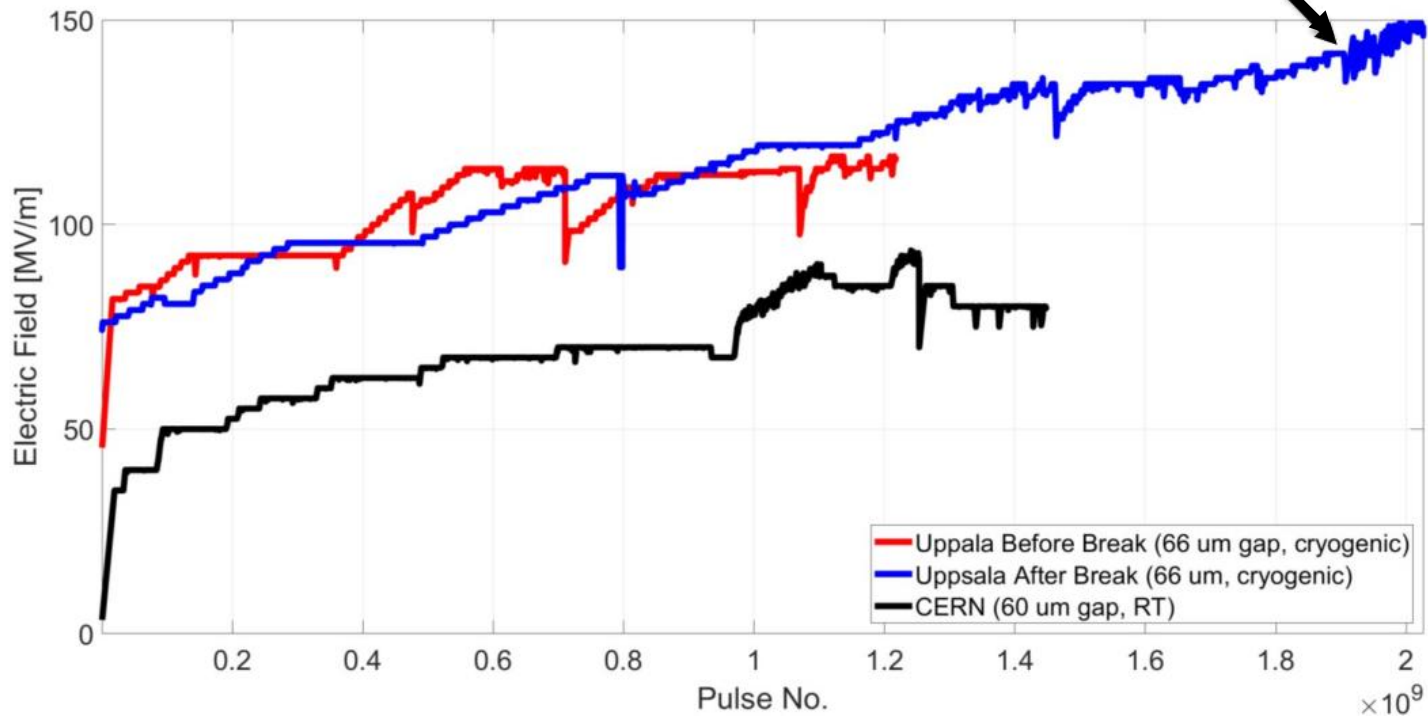

More on Nb conditioning in the following talk by M. Coman!

Microscopy Nb

Cathode

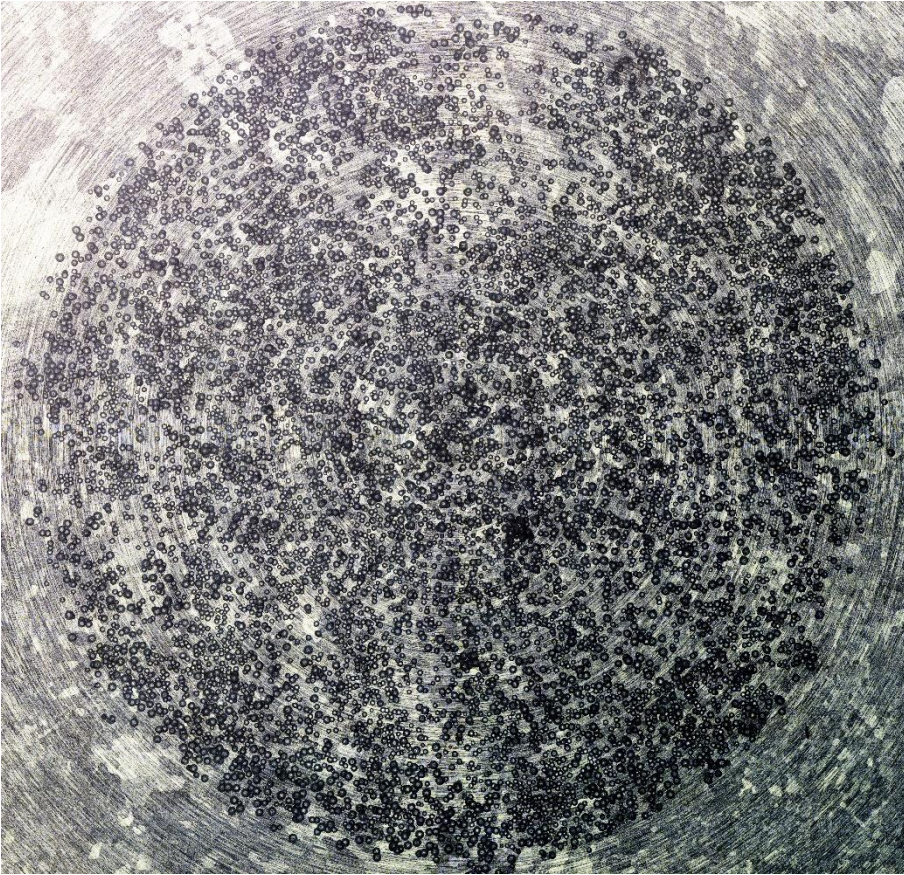

Anode

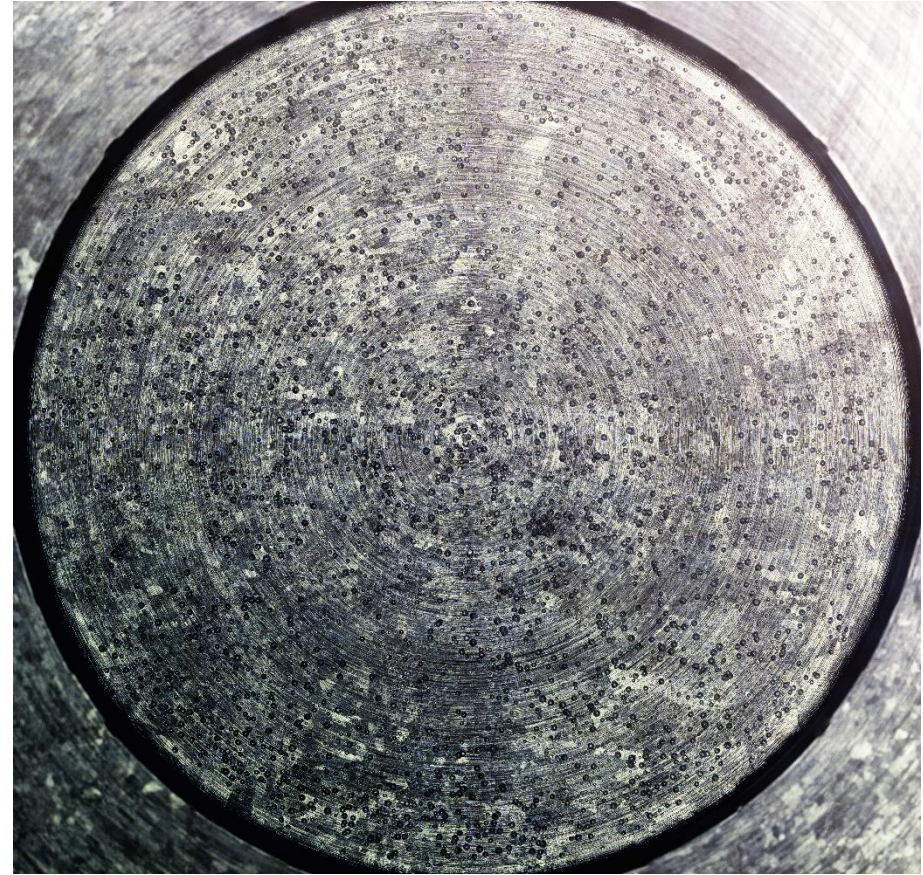

Microscopy Nb

Cathode

Anode

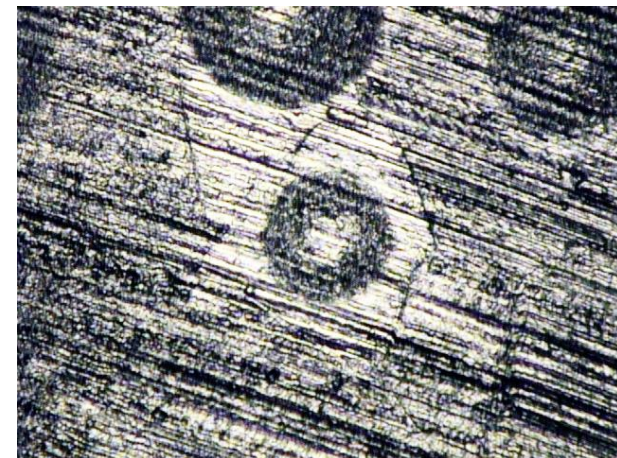
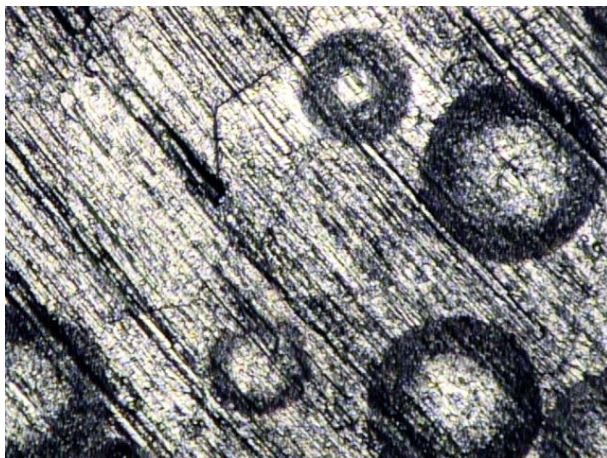
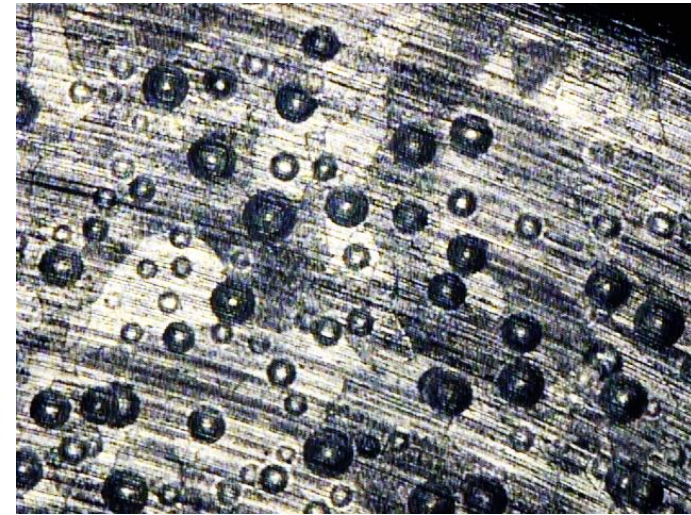
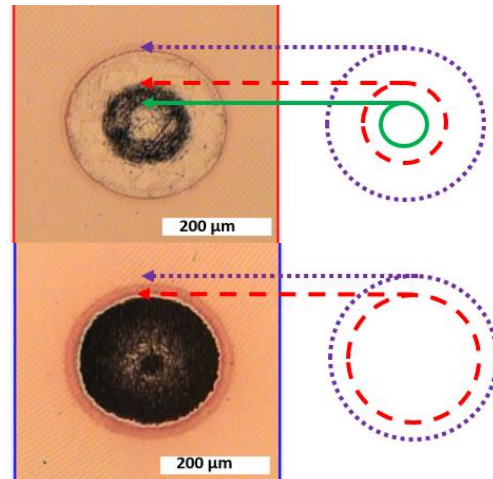
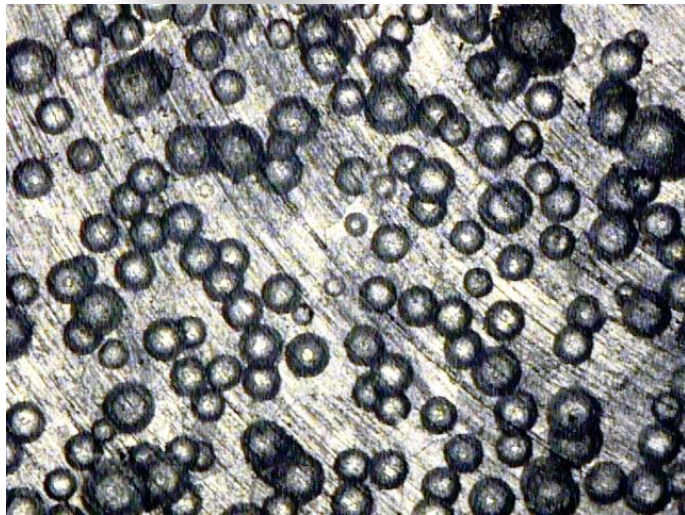

This Nb sample was remachined and buffered chemical polished – non standard treatment

Nb – profile through BD spot

Grooves clearly visible below melted Nb, only part of the groove is filled by fresh material
 Edge of the crater + 0.45 μm , Lowest point in the center: -0.6 μm
 → Roughly the depth of the cratered due to discharge is 1 μm

In spite of rough features surface conditioned to very high field (150 MV/m)

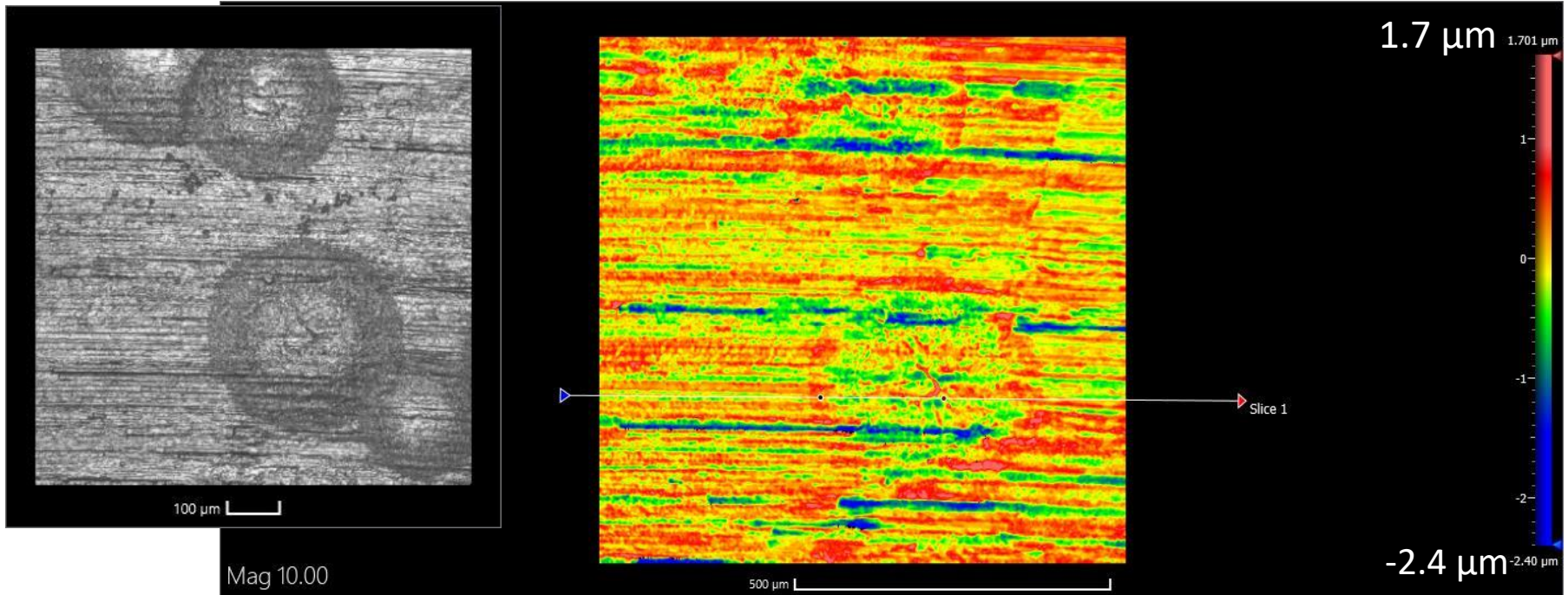

Mag 10.00

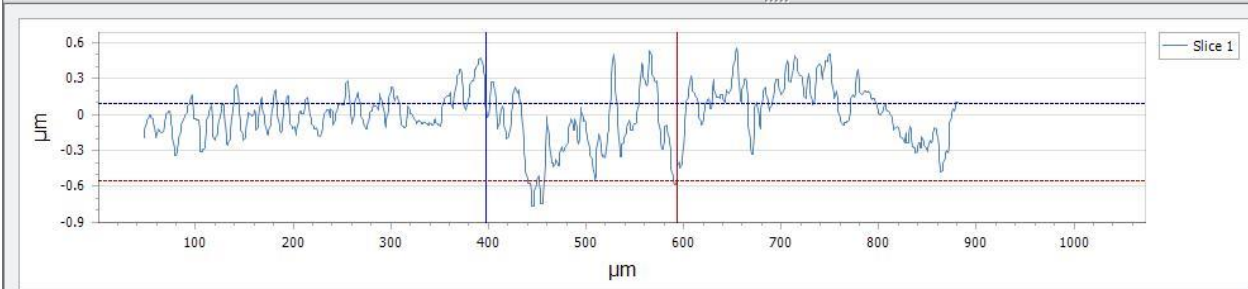

Inspector		
Y Distance	-0.639	μm
X Distance	195.554	μm
Angle	-0.187	$^{\circ}$

Microscopy Nb – BD spot characterization

1500 BD sites were chosen and in 97% match was found between anode and cathode side

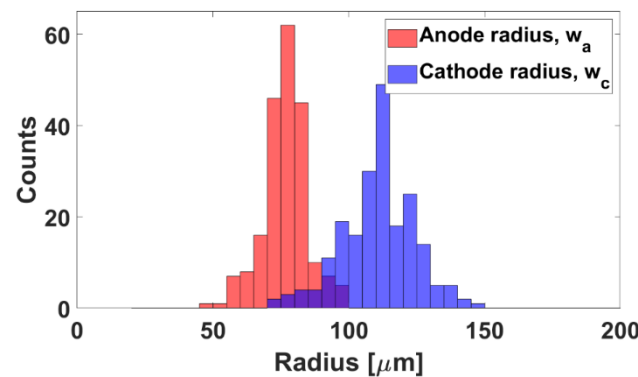
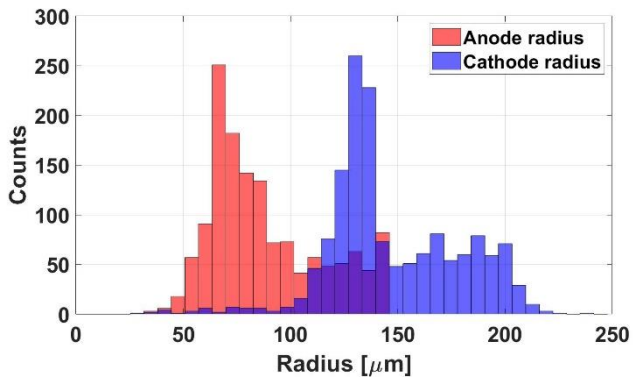
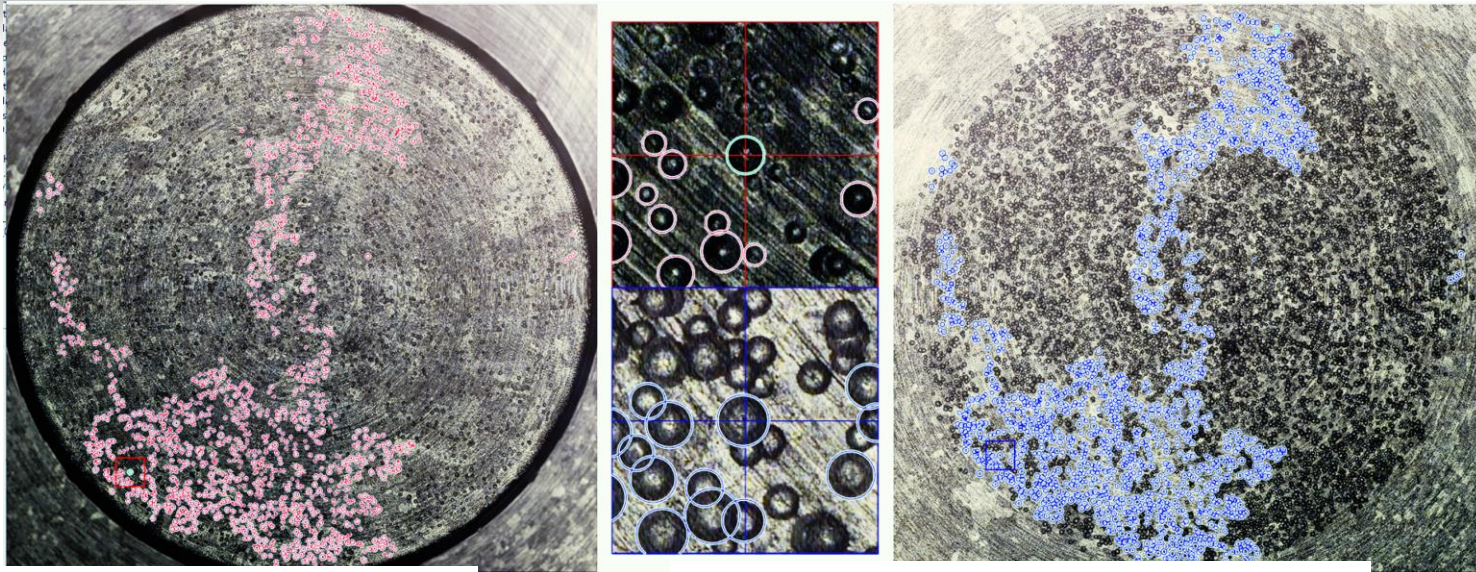

Nb - radii

$$R_c = 146 \pm 28 \mu\text{m}$$

$$R_a = 88 \pm 31 \mu\text{m}$$

$$\text{Ratio } R_c/R_a = 1.75 \pm 0.3$$

038-Cu - radii

$$\text{Ratio } R_c/R_a = 1.6 \pm 0.3$$

$$R_c = 125 \pm 16 \mu\text{m}$$

052-Cu - radii

$$\text{Ratio } R_c/R_a = 1.5 \pm 0.2$$

$$R_c = 111 \pm 16 \mu\text{m}$$

Cluster behavior

Breakdown classification into primary and secondary events

Very preliminary

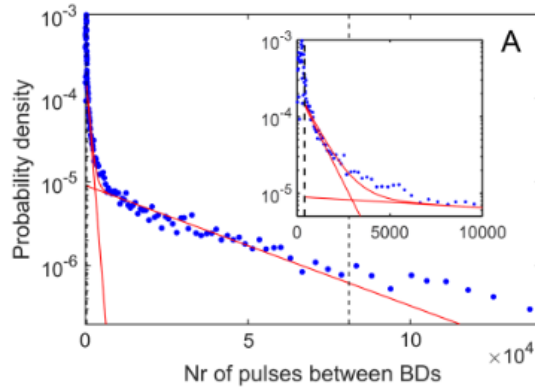

Fit of sum of 2 exponentials to distribution of #pulses between 2 consecutive BDs

$$PDF(n) = Ae^{-\alpha n} + Be^{-\beta n}$$

the **tail** distribution corresponds to a base rate of **primary** breakdowns, α
the **head** distribution corresponds to follow-up rate of **secondary** BD, β

Spatial relation for secondary BDs, confirmed in DC system (however different for soft and hard Cu)

Wuensch, W. *et al. Phys. Rev. Accel. Beams* **20**, 011007 (2017).

Korsbäck, A., Djurabekova, F. & Wuensch, W. *AIP Advances* **12**, 115317 (2022).

Distributions of cluster sizes can be explained by assuming that every BD induces a number of follow-up BDs that are Poisson-distributed with $\lambda < 1$

Interpretation: primary and follow-up breakdowns are categorically different kinds of events with different underlying causes and mechanisms.

In the paper no relation to other conditioning parameters were studied

We have now large set of data with different temperatures and conditioning parameters that can look into these relations

Can the cold setup provide further insight into these mechanisms?

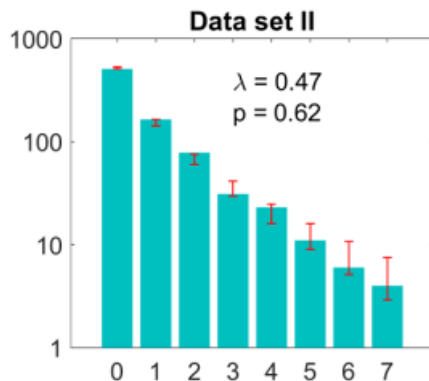

Cluster behavior – data from cryo DC system

Very preliminary

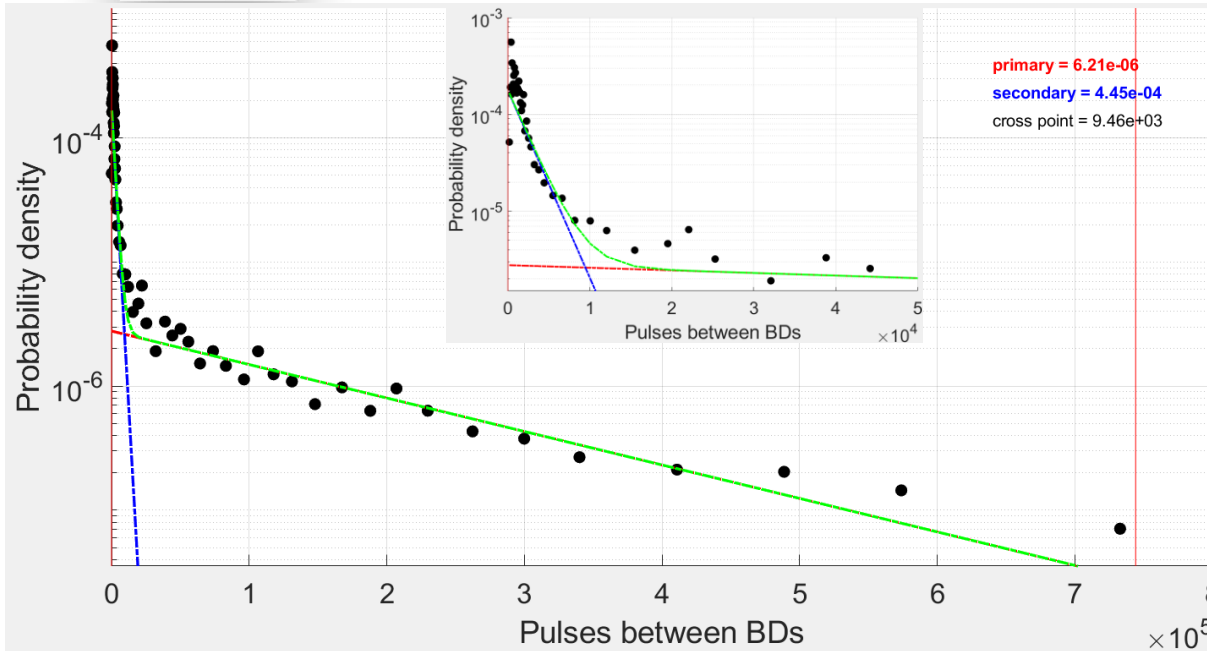

2 exp fit gives α, β and cross point value

Cross point \rightarrow selecting primary cluster to produce the histogram with cluster sizes

Cluster data fitted with MC based on unique λ

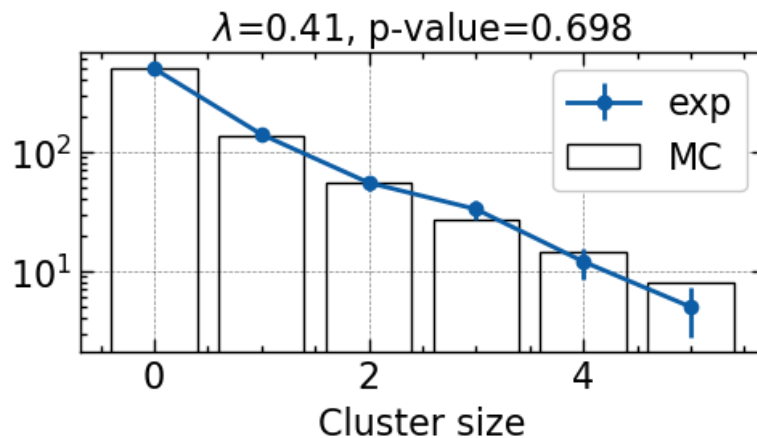

Most of the fitted data gives p-values that indicate consistency between the data and the PMF



Cluster behavior – data from cryo DC system

Single electrode pair, SOFT Cu

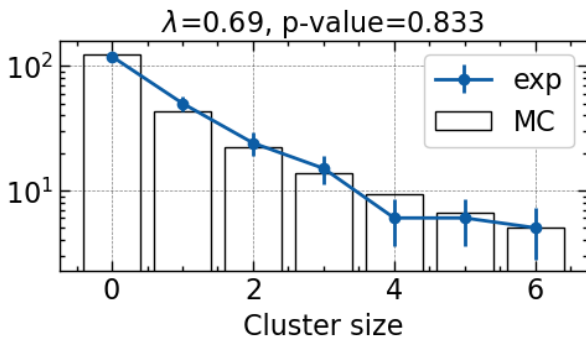
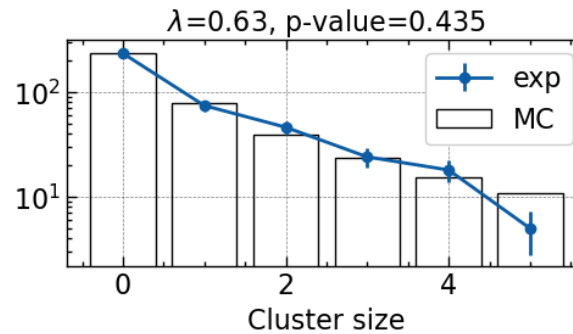
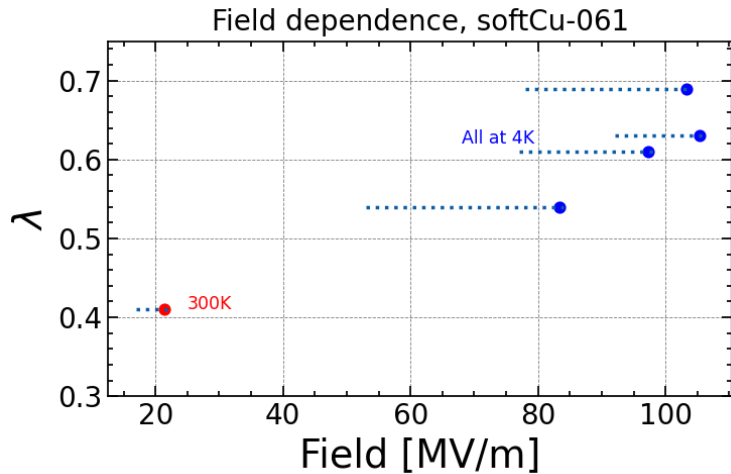
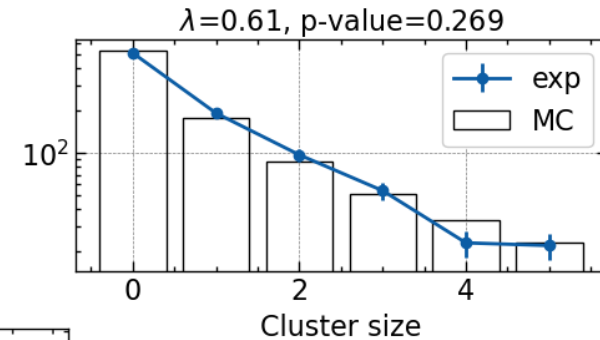
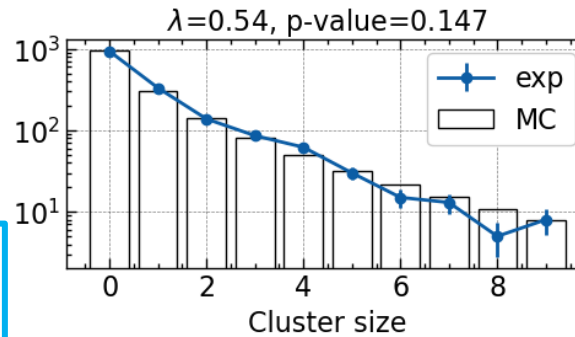
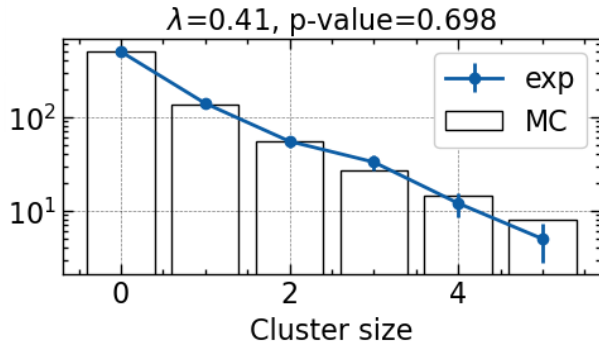

Cluster behavior in DC wrt to Temperature

Very preliminary

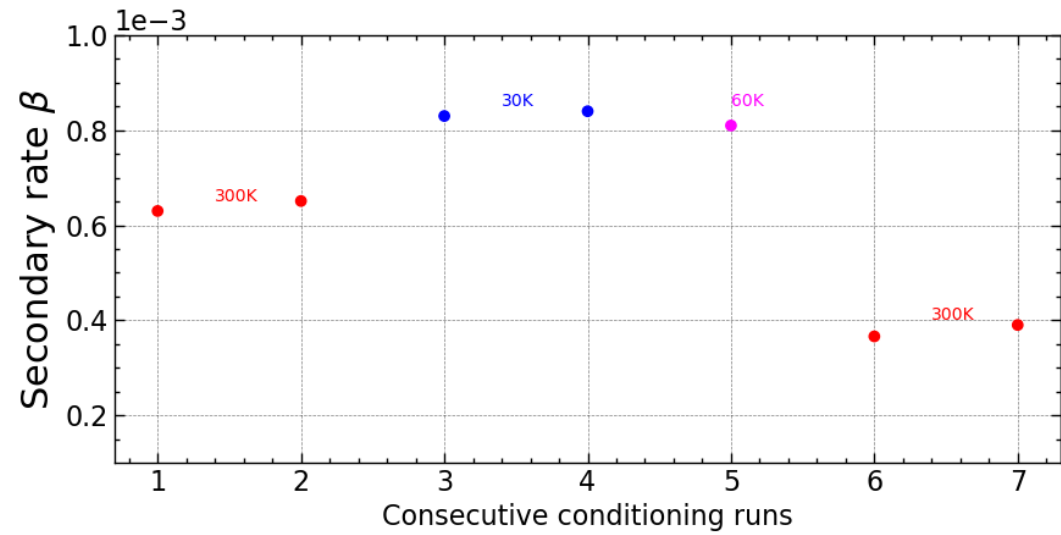
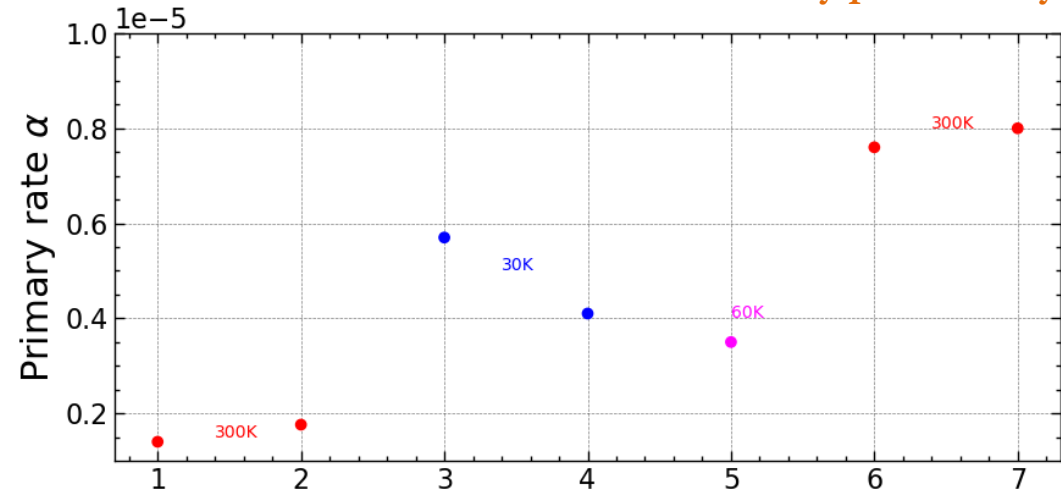
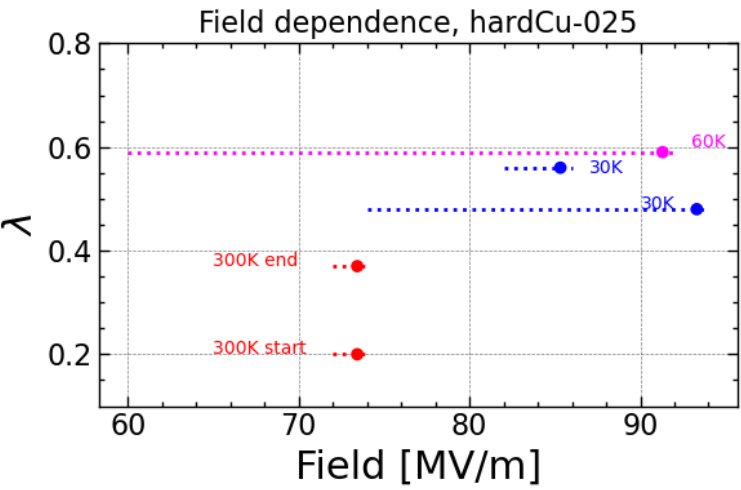

Surface undergo dynamic changes over the course of conditioning and it is visible in their breakdown behavior

Cluster behavior in DC wrt to Temperature

Samples only conditioned in cryo temperatures

Very preliminary

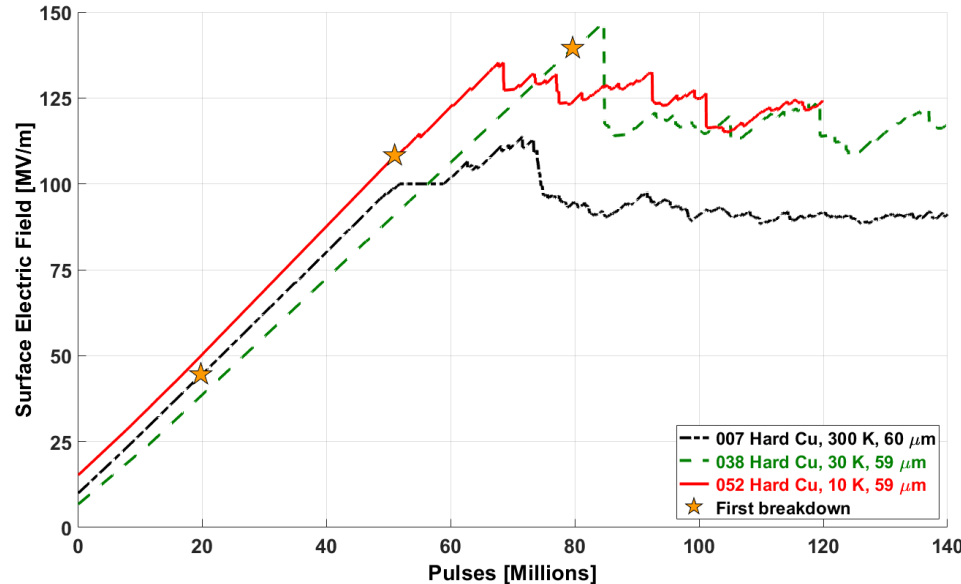

For Cu samples conditioned only in cryo temperature, presented before (038, 052) → fit results showing a **statistically significant difference** between the data and the fit. No longer Poisson process with single λ ?

But almost all BD were recorded after the field drop – too aggressive conditioning – deconditioning effect visible in cluster behavior?

Summary

- ✓ The temperature “knob” is a great way to further explore the limits on accelerating gradient
- ✓ Cathode and anode surface morphology → may shed light on process that dominates BD formation, e.g. pre-BD phase, instabilities during thermal runaway and initial explosion ; simulations needed
- ✓ First comparison of BD spots on Nb vs Cu reveal quite similar features wrt size and shape, but no star-like features on Nb
- ✓ Preliminary results on changes in clustering mechanism shows trends with temperature and field, could help optimize conditioning process



Thank you for attention

Surface resistivity measurements during high-field conditioning

Main motivation: Test the dislocation hypothesis

How?

- Cryogenic environment + DC conditioning + RF resistivity measurement

The electrode system needs to be **modified**:

- Anode: a groove (choke) to contain a resonant mode between electrodes) (idea thanks to J. Paszkiewicz and S. Calatroni)
- Cathode: for better/safer antenna coupling

We have tested a prototype to confirm the concept (at room temperature)

First set in production at CERN

We are getting ready for first measurements

BONUS: RF antenna inside the system = new methods of investigating breakdowns.

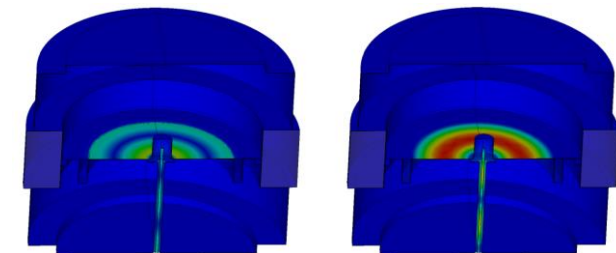
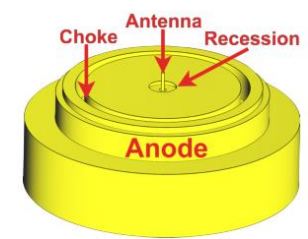
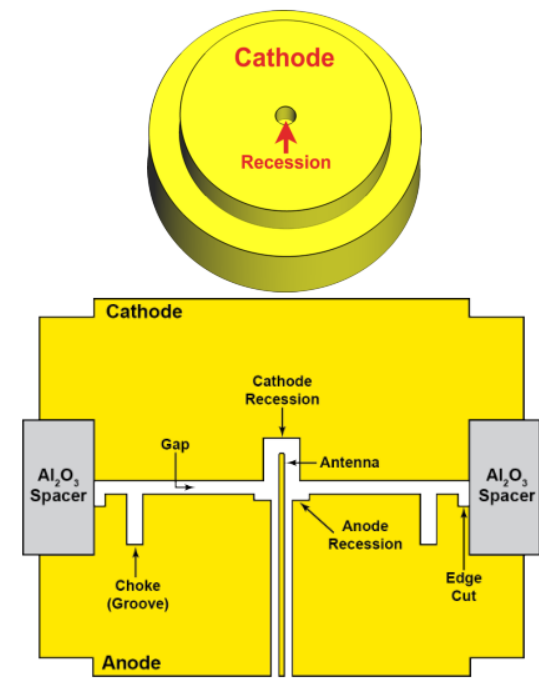

Statistical analysis

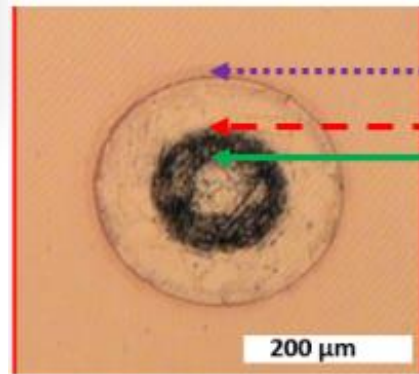

(a) Anode

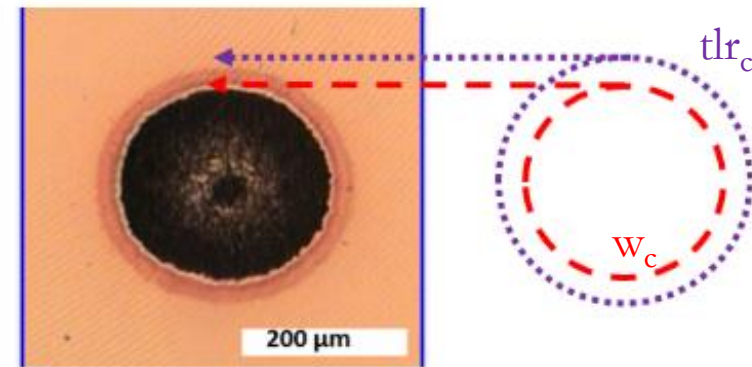

(b) Cathode

	300K	30K	10K
W_c [μm]	101±20	125±16	111±16
W_a [μm]	73±12	78±11	76±10
W_c/W_a		1.63±0.3	1.47±0.2
tlr_c/tlr_a		0.99±0.2	1.0±0.2
tlr_a/W_a		1.92±0.3	1.96±0.2
tlr_c/W_c		1.19±0.2	1.34±0.2

BD spot for a typical BD event is 4 times larger than the gap size
 Plasma fills a substantial part of the gap between the BD spot
 Cathode spots feature clear melting and reshaping of the surface

But looking at anode:

- The traces from machining are visible over anode's most inner lighter disk → no significant melting
- Dark wavy part covers or removes the grooves
- No radial jets around the anode BD feature (supports no-melting hypothesis)
- No significant differences between RT and cryo

So what can cause such a specific morphology of anode spots?

BD site - up to scale

anode



cathode



Ti: very regular machining grooves
 Min-Max: ~0.8 μm

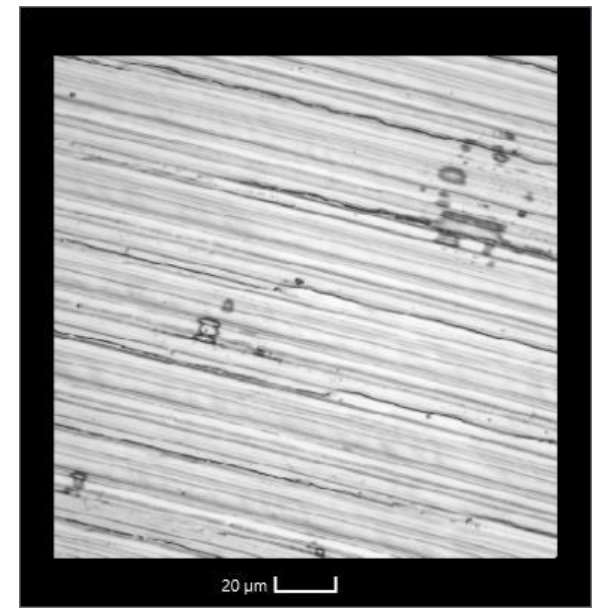
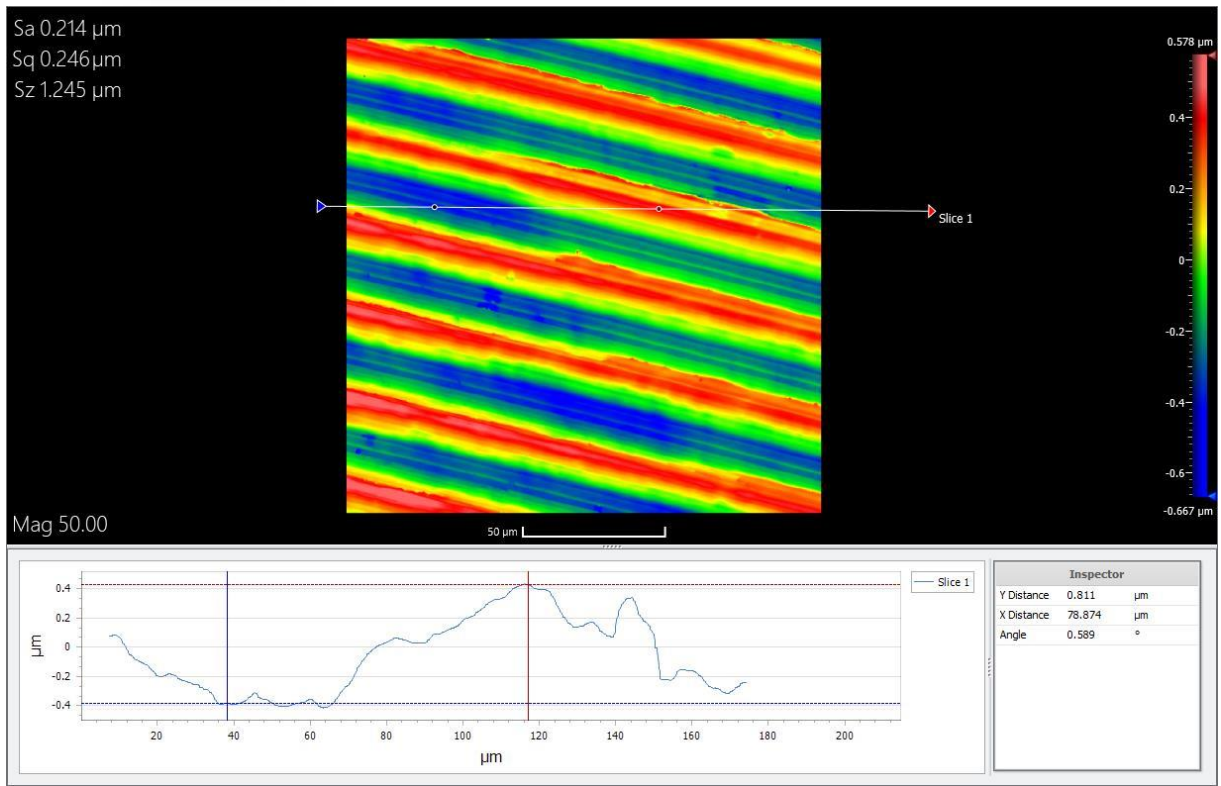

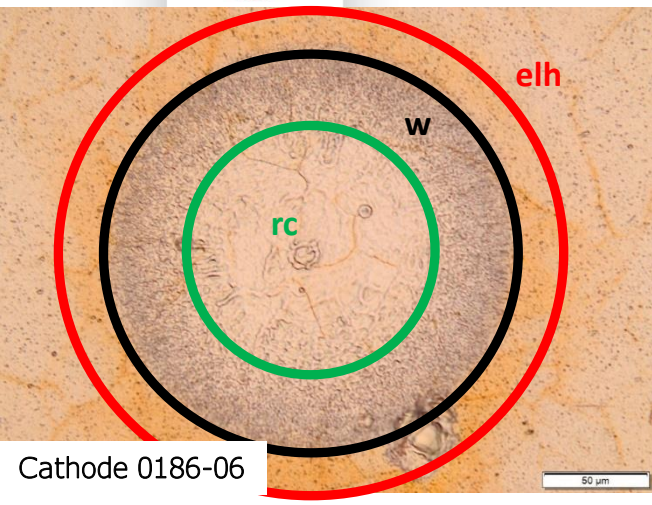

Cathode vs anode BDs at 300 K

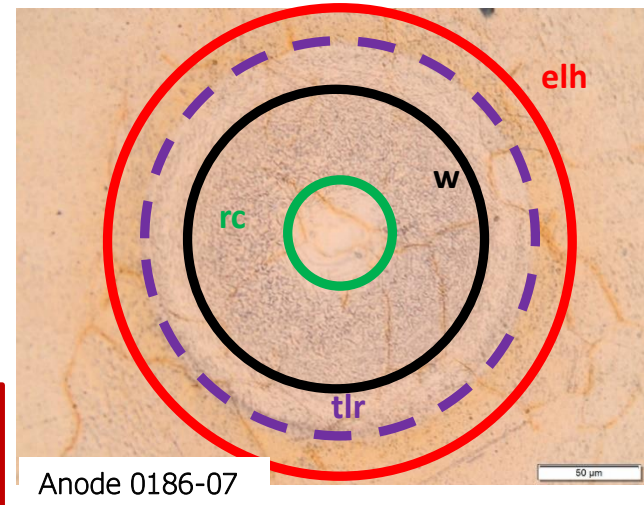

elh – extra-large halo
tlr – thin light ring
w - wavy circumference
rc – reflective central part

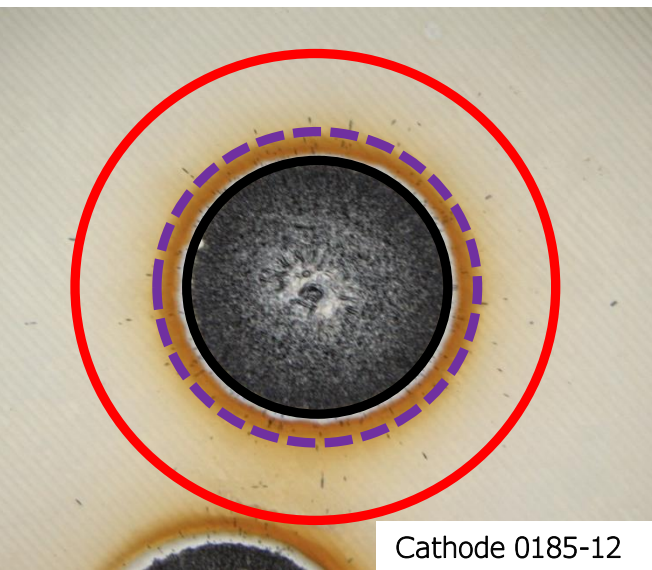

Cathode vs anode BDs at 30 K

