A 500 kV SF₆ insulated feedthrough for inverted insulator photoguns

Gabriel Palacios, Carlos Hernández García, Matthew Poelker

Thomas Jefferson National Accelerator Facility

gabrielp@jlab.org

Outline:

- Overview of DC photogun designs in operational accelerators at Jefferson Lab
- Practical considerations to reliably apply high voltage
- Successes and failures learned over the two past decades
- Latest developments on 500 kV feedthrough



Jefferson Lab CEBAF

- The Jefferson Lab CEBAF provides high polarization CW beam to four nuclear physics experimental halls
- The electron source is based on a 180 kV DC photogun with strained super lattice GaAs photocathode
- The accelerator is based on SRF linacs providing ~ 2 GeV / pass

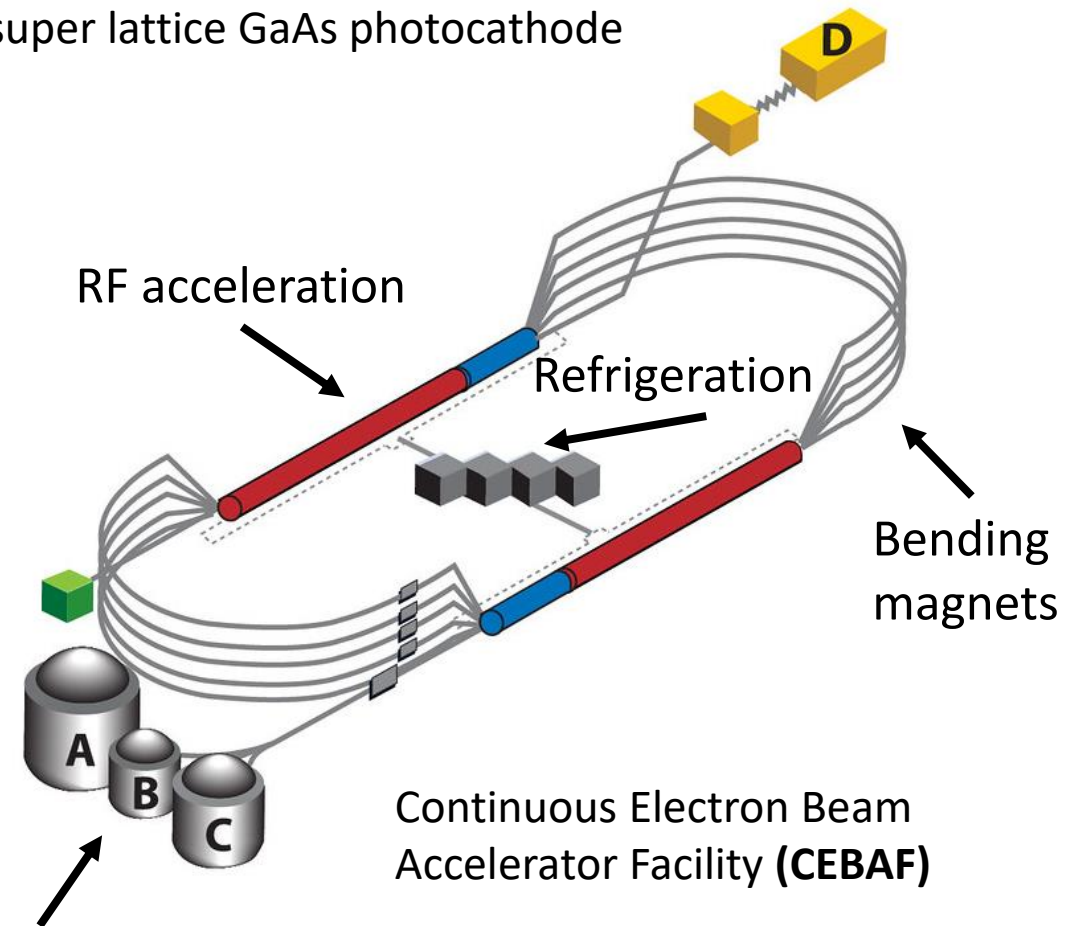

Experimental
halls

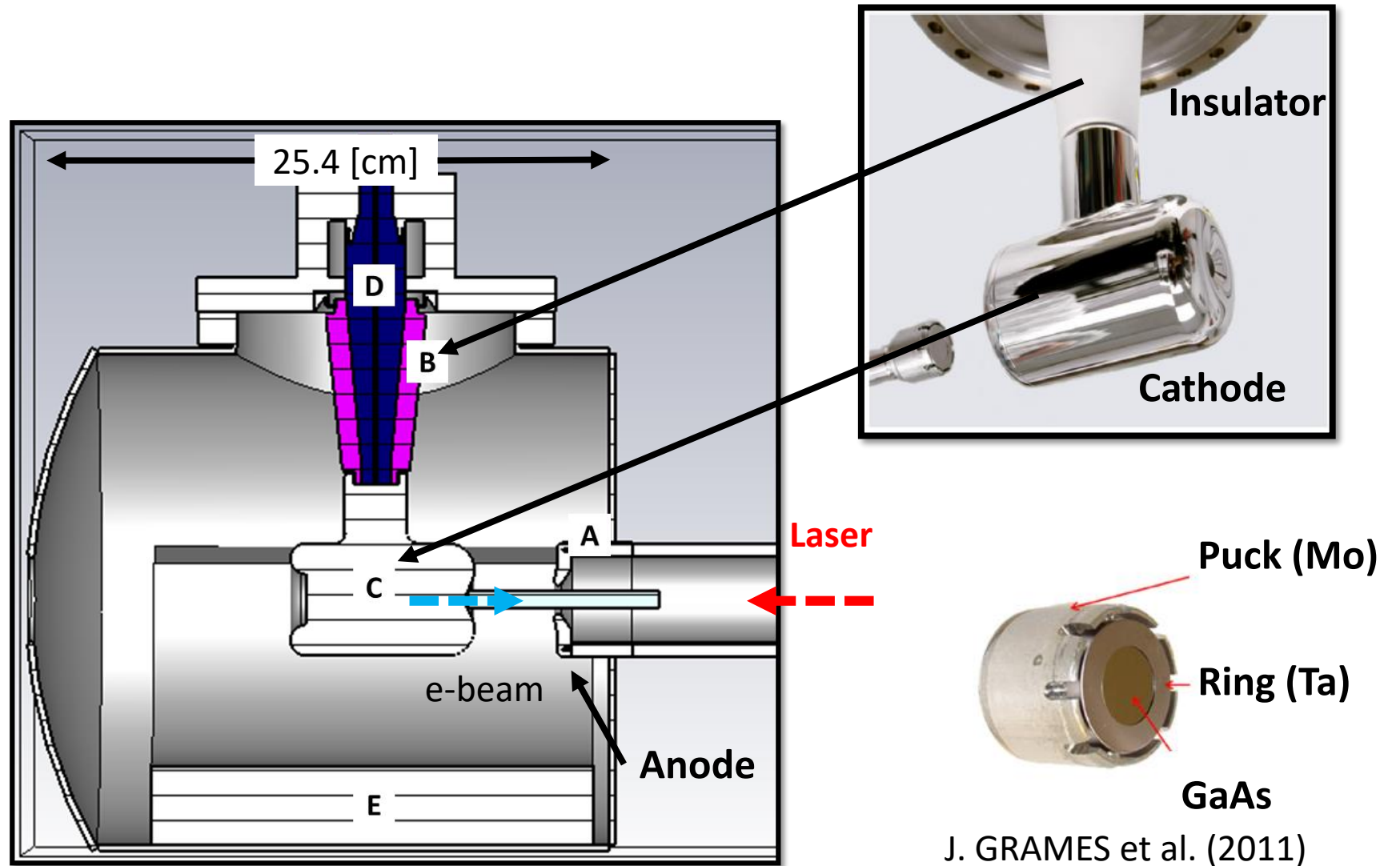

Longitudinal cross section of the existing CEBAF 130keV photogun

High Voltage DC photogun

High Voltage DC photoemission gun characteristics makes them an ideal electron beam source in a variety of accelerator applications

- Extreme-high vacuum conditions provide long-photocathode lifetime for nuclear physics experiments
- High beam current capability provide:
 - Hundreds of micro-Amperes > 80% spin-polarized electron beams for nuclear physics experiments
 - Tens of milli-Amperes un-polarized beams for electron coolers, energy recovery linacs and free electron lasers
- High photocathode gradient contributes to managing space charge forces in high intensity bright electron beams for accelerator applications
- High voltage must be applied to the electrodes and HV feedthroughs without breakdown

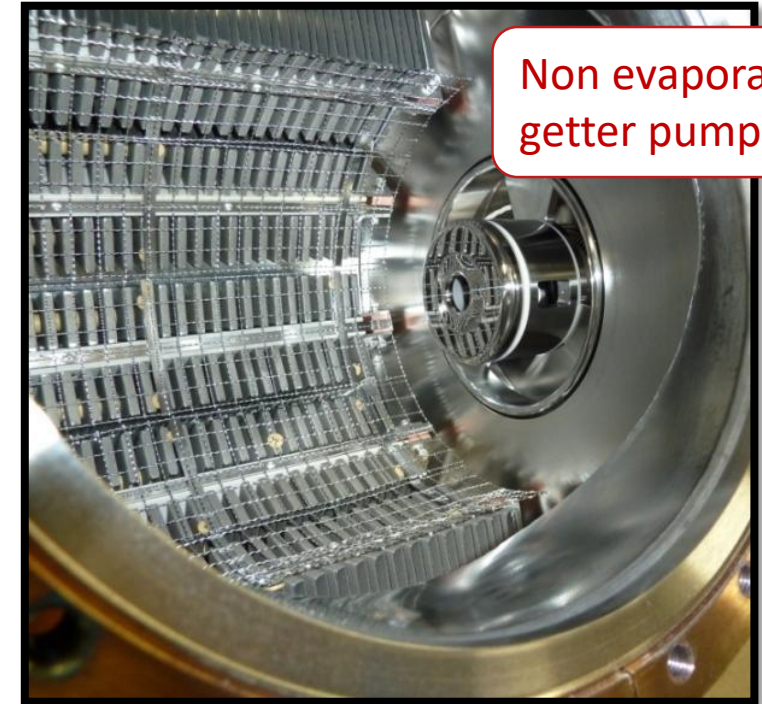

Non evaporable
getter pump array



GaAs photocathode



Insulator

Field emission (FE) is a harsh opponent.

- Material choice
 - Minimal amount of inclusions and defects
 - Increased material hardness helps with field emitter 'growth', but once developed field emitters are more difficult to process out, and electrode is more difficult to polish
- Small size to minimize surface area for better vacuum, but shape and size to minimize gradient
- Mirror finish polishing to minimize surface roughness
- Vacuum heat treatments to reduce outgassing for vacuum performance
- UHV chemical cleaning and high pressure rinsing to minimize potential field emitters from particulates
- Assembly in best possible clean room conditions to minimize number of foreign particulates
- High voltage conditioning, using Kr gas helps processing field emitters

Similar practices apply to the vacuum chamber and anode electrodes to minimize *voltage induced gas desorption*, typically observed > 200 kV

Mirror polished to minimize FE

- Diamond paste polishing is a labor intensive process that takes about 3 weeks
- Implementing centrifugal barrel polishing has reduced polishing time from weeks to hours

From machine shop



After barrel polishing
60 min. plastic cones
60 min. crushed **corn**cob



Barrel polishing machine at JLab SRF



* C. Hernandez-Garcia, D. Bullard, F. Hannon, Y. Wang and M. Poelker, Review of Scientific Instruments **88**, 093303 (2017)

Surface finish of electrodes

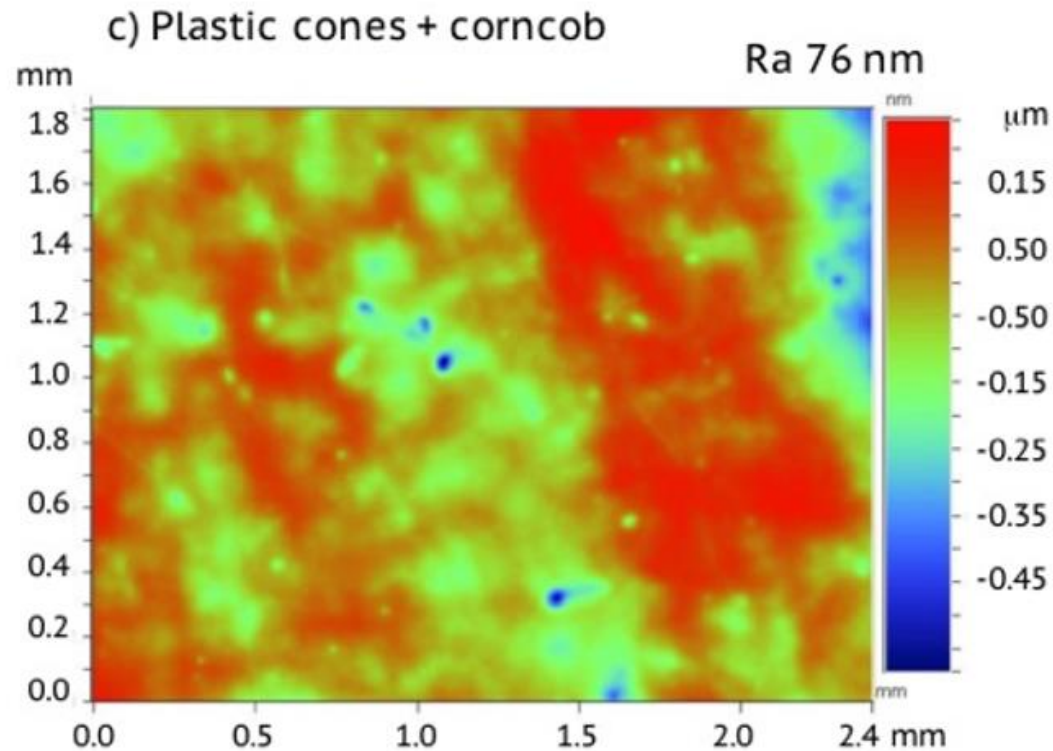

Diamond paste polishing Ra 30 nm*

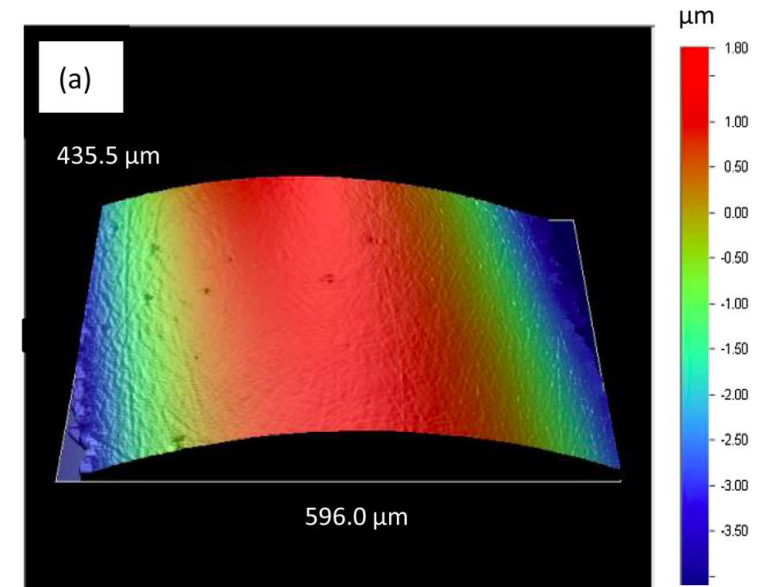

- Profilometry measurements shows surface rms roughness is comparable between the two polishing methods

* C. Hernandez-Garcia, D. Bullard, F. Hannon, Y. Wang and M. Poelker, Review of Scientific Instruments **88**, 093303 (2017)

High voltage conditioning with Kr gas serves to eliminate FE*

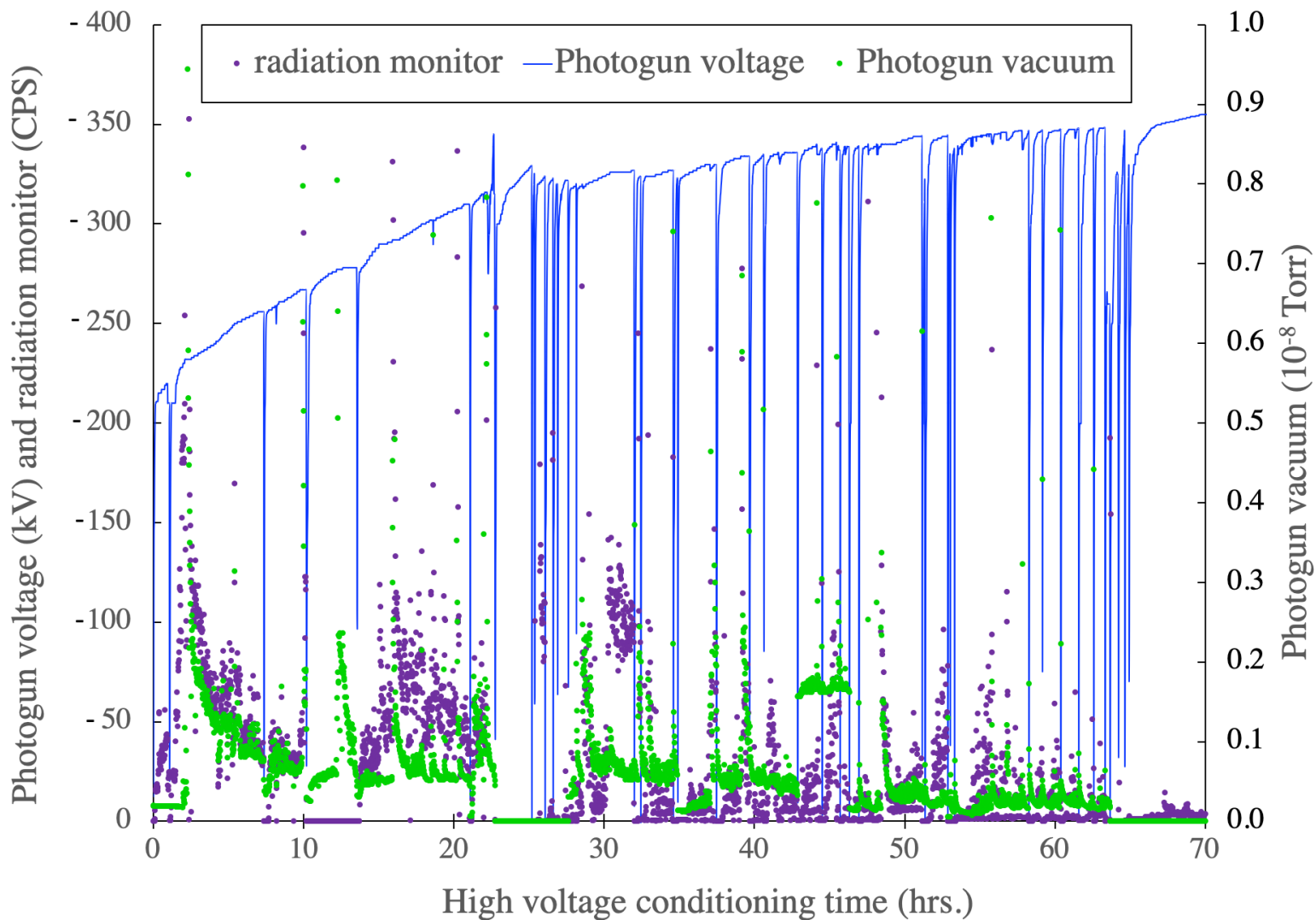

- The purpose of high voltage conditioning is to achieve vacuum and radiation levels indistinguishable from background at operation voltage
- Kr gas is injected at $\sim 10^{-5}$ Torr into the gun vacuum chamber during high voltage conditioning.
- Kr processing 'burns out' FE sites by ion back bombarding and by increasing stainless steel work function as it is implanted at the gun electrode

*M. BastaniNejad, A. A. Elmustafa, E. Forman, J. Clark, S. Covert, J. Grames, J. Hansknecht, C. Hernandez-Garcia, M. Poelker and R. Suleiman, "Improving the performance of stainless-steel DC high voltage photoelectron gun cathode electrodes via gas conditioning with helium or krypton", Nucl. Instr. and Meth. in Phys. Res. A, Vol. **762**, pp. 135–141, 2014

Inverted-geometry ceramic insulators:

- The cathode is isolated from the vacuum chamber at ground potential with a conical (inverted geometry) insulator feedthrough

- The cathode is connected to the high voltage power supply via the feedthrough using a cable

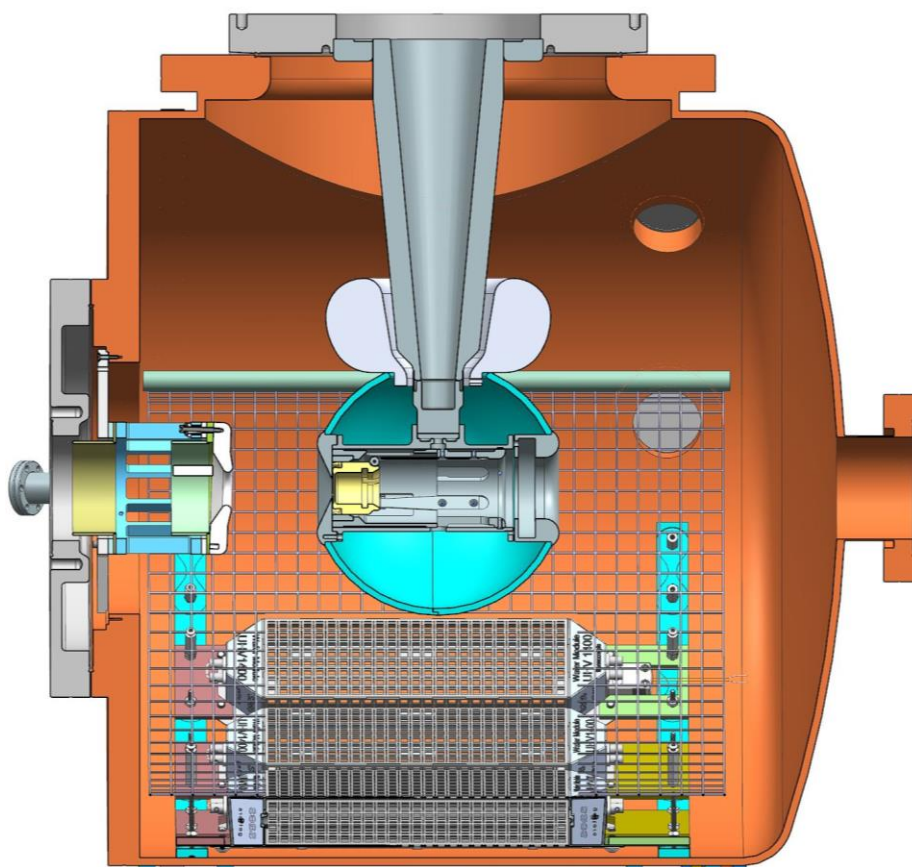

← 15 cm →

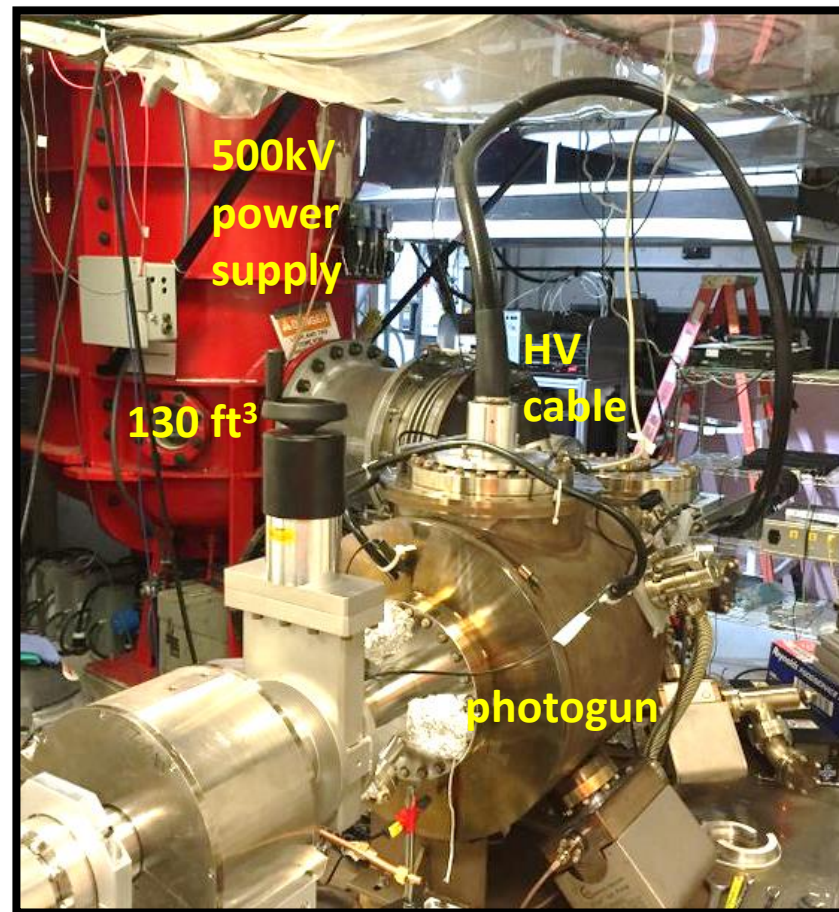

Commercial high voltage cables

180 kV CEBAF
Nuclear Physics program

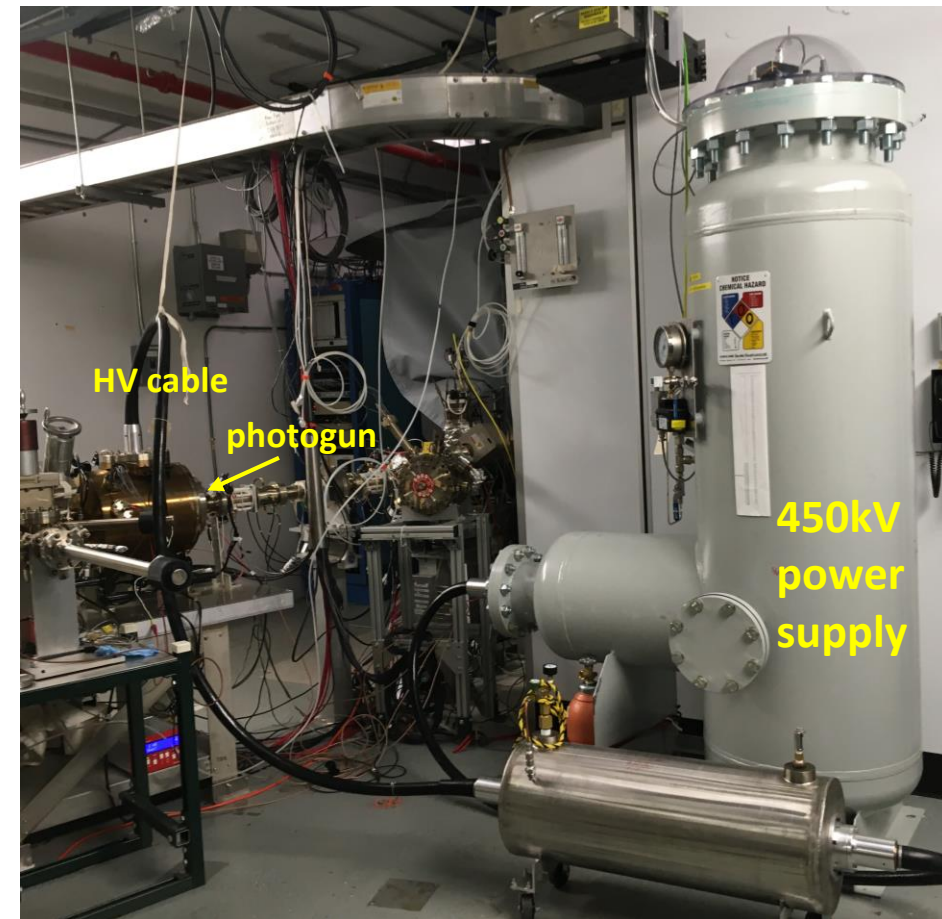

200 kV Beam
Test Accelerator

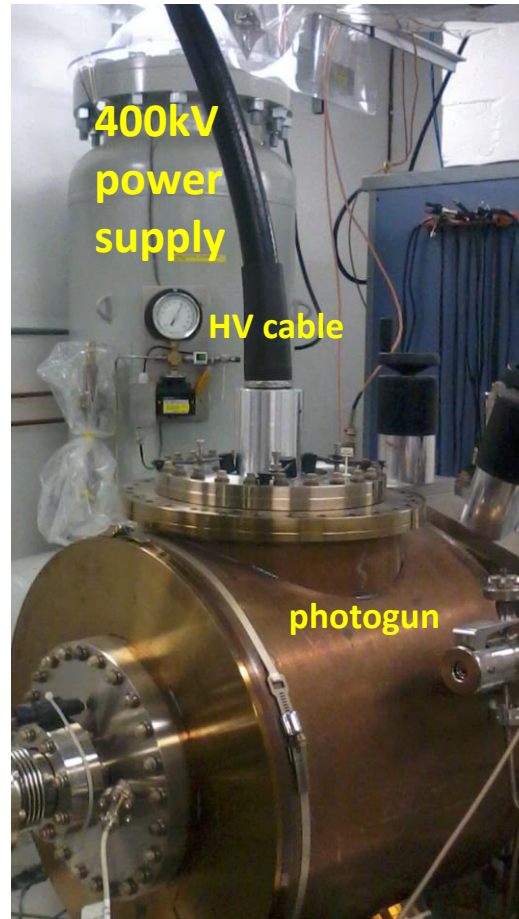

350 kV Gun Test Stand

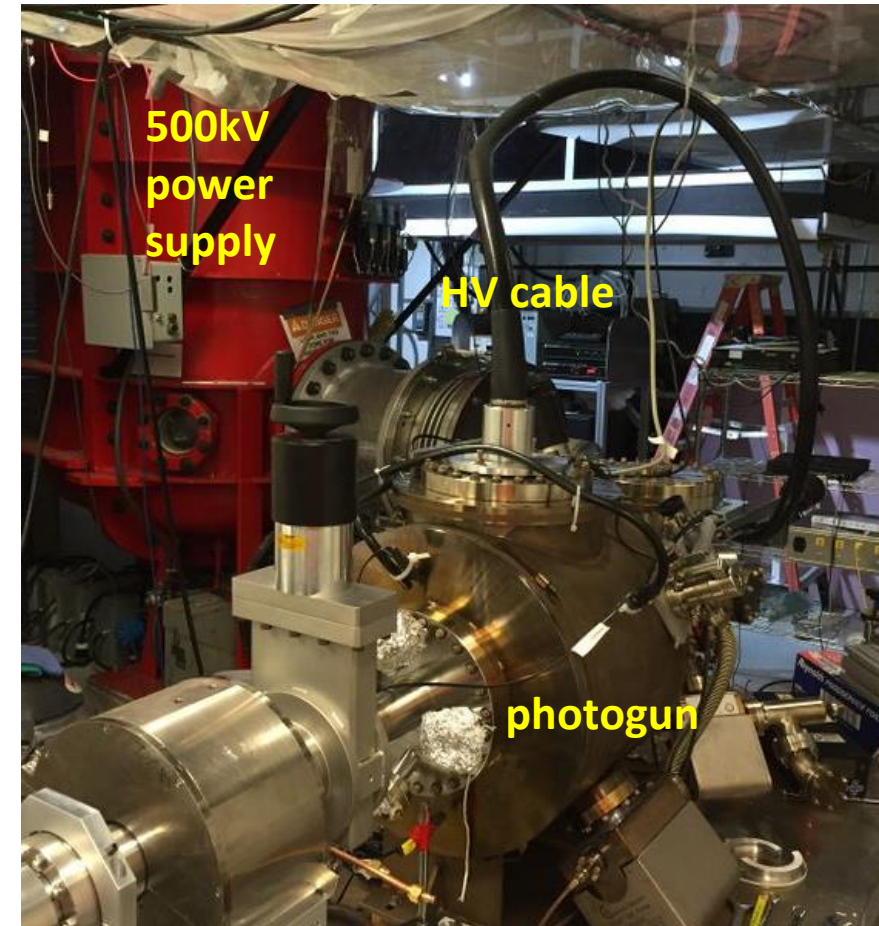

The reality of HV breakdown

The first test with **R30** pure alumina ceramic suffered breakdown at **~315kV** with subsequent puncture at **330kV**.

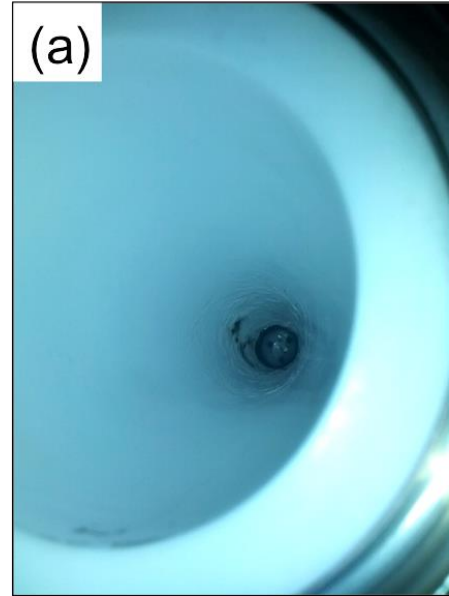

A second test with a **new R30** pure alumina suffered breakdown at **~315 kV**.

Field emission managed via krypton-processing*, i.e., voltage was applied with $\sim 10^{-5}$ Torr krypton added to gun chamber

* C. Hernandez-Garcia, M. Poelker, and J. Hansknecht, "High Voltage Studies of Inverted-geometry Ceramic Insulators for a 350 kV DC Polarized Electron Gun," IEEE Transactions on Dielectrics and Electrical Insulation Vol. 23, No. 1; February 2016

Triple point junction shield



Using a triple point junction shield was key for reaching 350 kV with no breakdown using the pure alumina R30 insulator

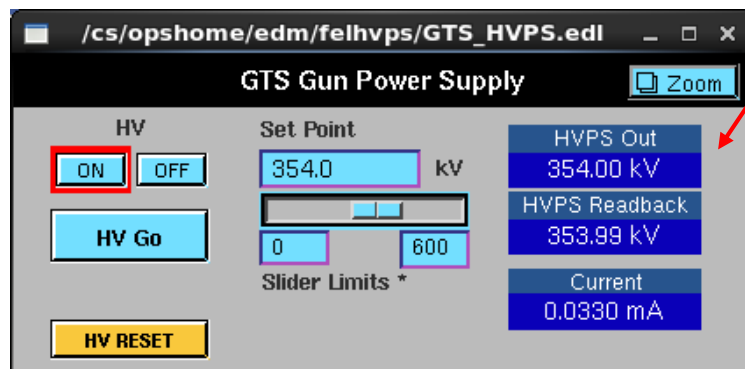
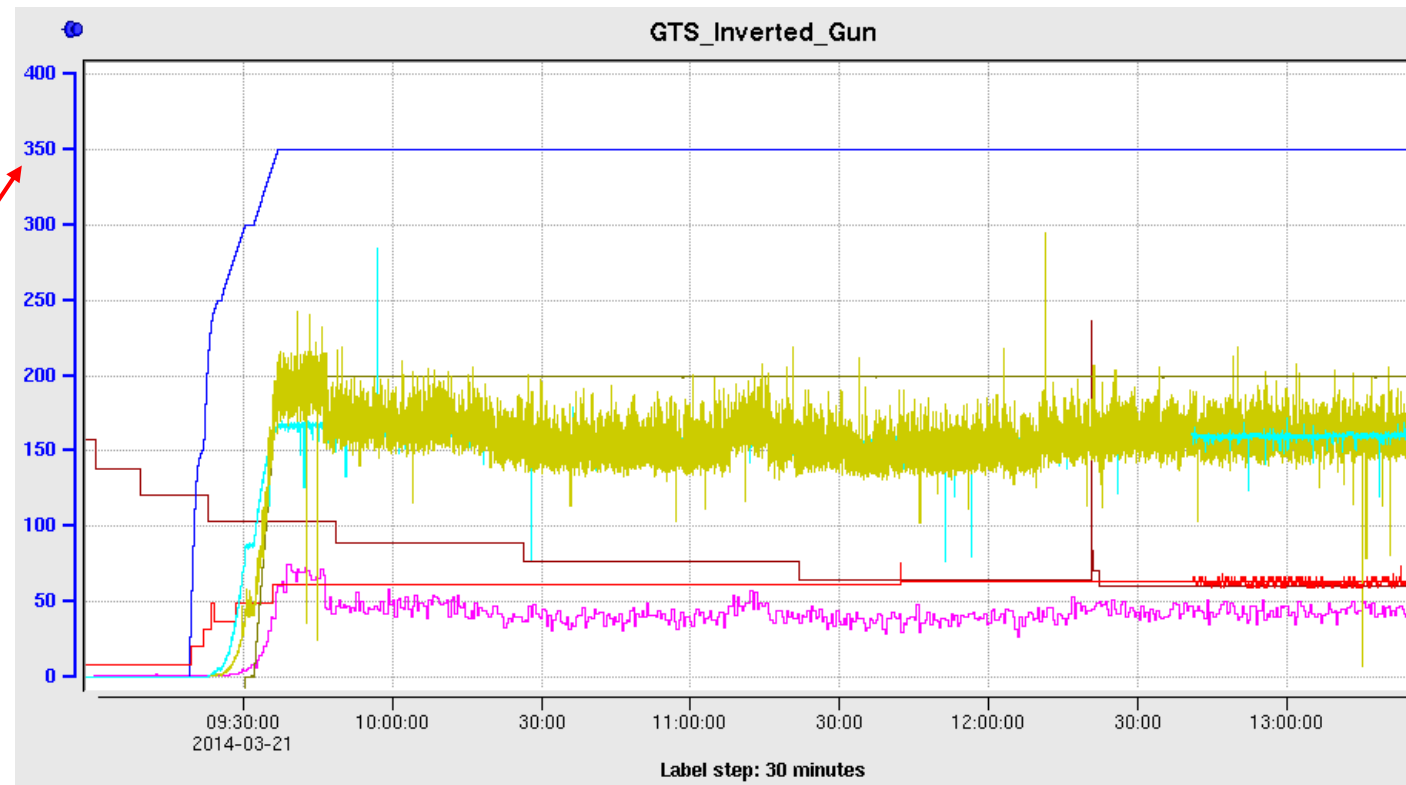

The quest continues

- Motivation: A 500 kV feedthrough design could then be used in a 400 kV photogun with margin for high voltage conditioning to generate **high bunch charge spin-polarized electron or positron beams**.
- No field emission at 400 kV!
- $\sim 1 \times 10^{-12}$ Torr while delivering beam!

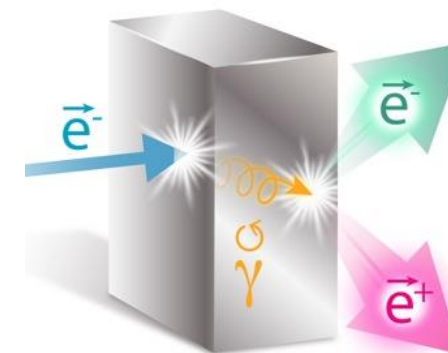

Physical Review Letters – Editor’s Suggestion and Focus Story

“**Production of Highly Polarized Positrons Using Polarized Electrons at MeV Energies**”. D. Abbott et al. (PEPPo Collaboration), Phys. Rev. Lett. 116, 214801 – Published 27 May 2016

- There is no inverted insulator feedthrough capable of 500 kV that fits commercial cable connectors
- Commercial cable connectors are rated to ~ 400 kV max in SF₆, and have never been tested > 350 kV connected to inverted insulators in vacuum

Development of high voltage inverted insulator photoguns

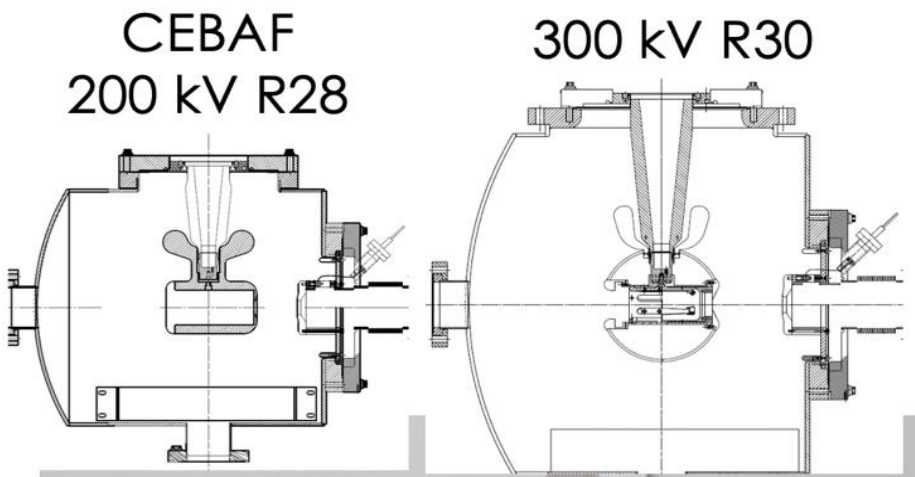

Next step: 500 kV

We have 6 of these customized insulators, but they do not fit to the cable shown below

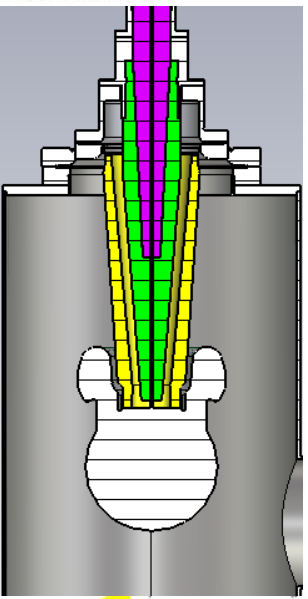

The 500 kV feedthrough R&D is an evolution from JLab experience developing and operating high voltage inverted insulator photoguns connected to power supplies using commercial components

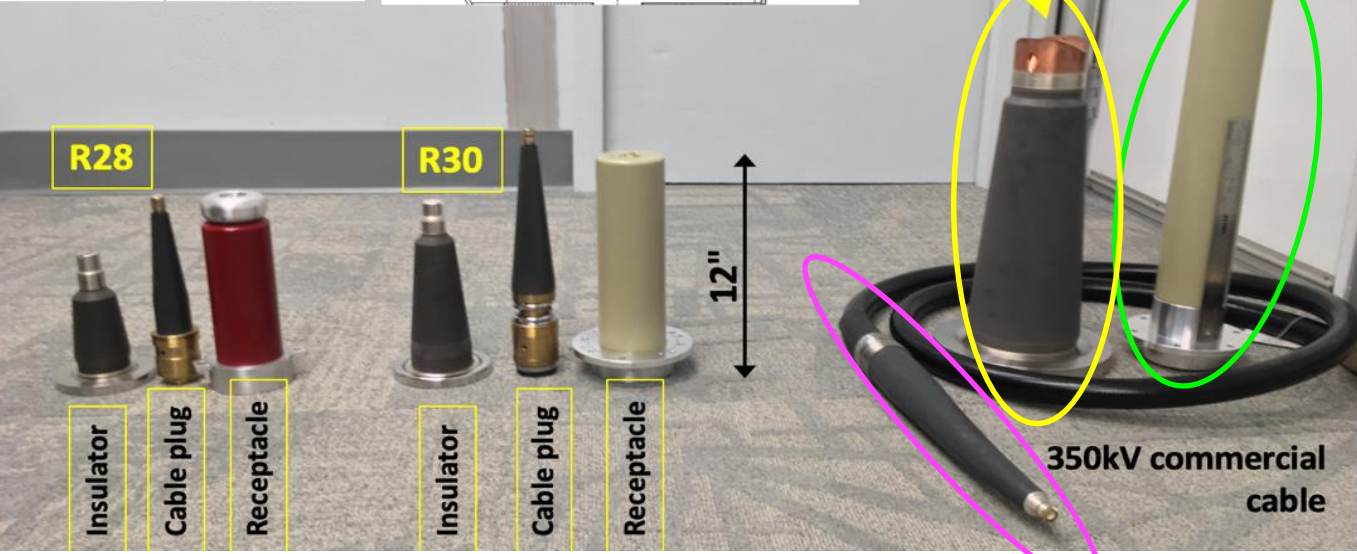

Conceptual approach: modify commercial epoxy receptacle designed for 350kV cable to mate with inverted insulator

Design and simulations

Gradients shown at 500 kV

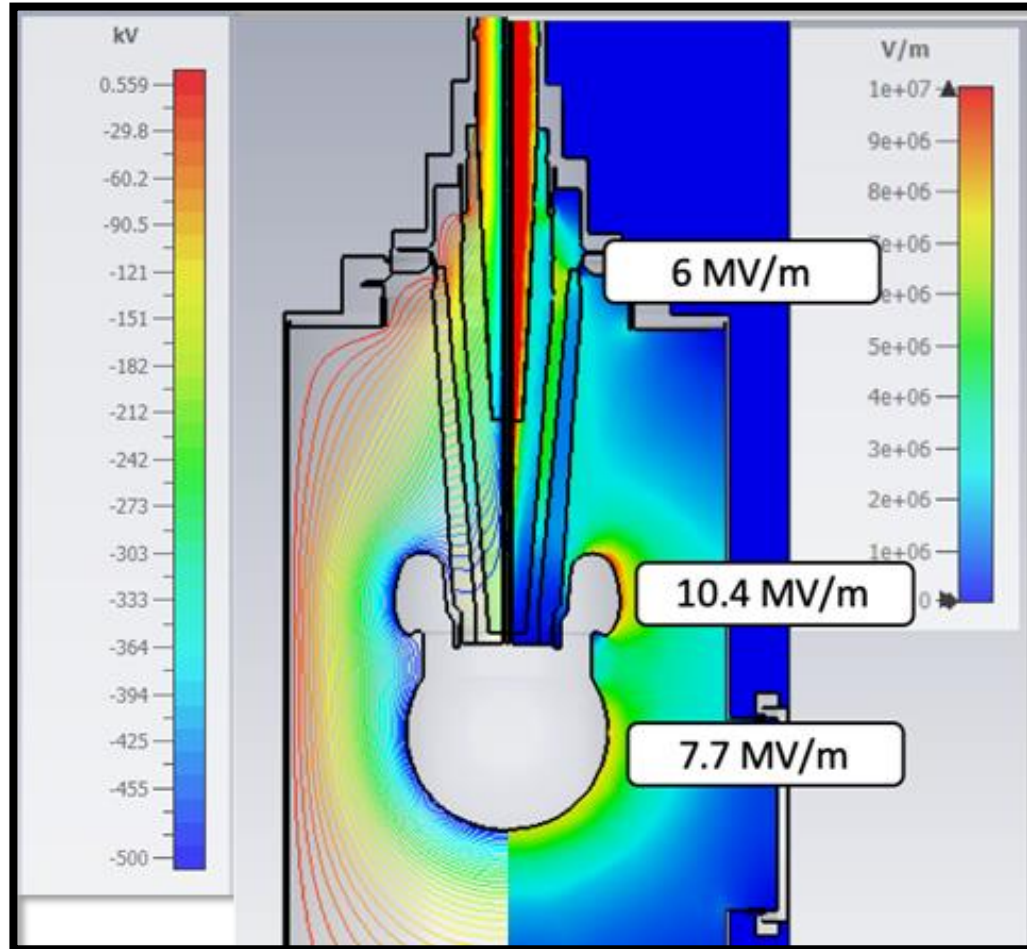

The test electrode and triple point junction shielding electrode were designed in CST EM to keep the maximum gradient at ~ 10 MV/m at 500 kV

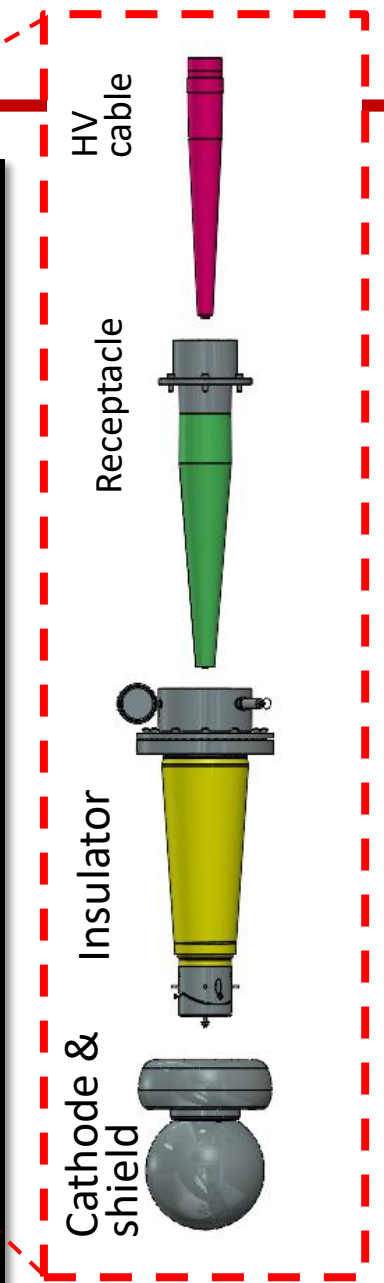
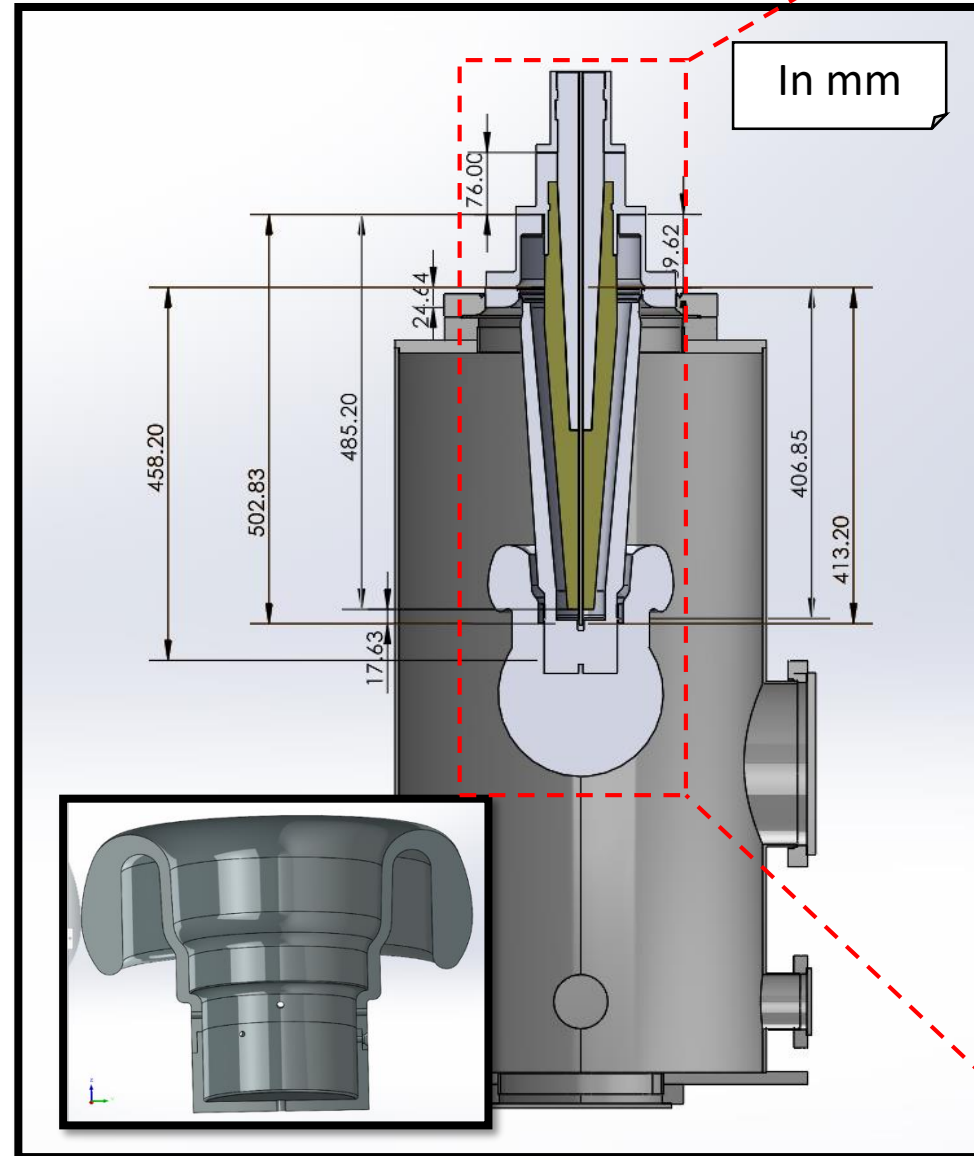

Development of 500 kV insulator feedthrough

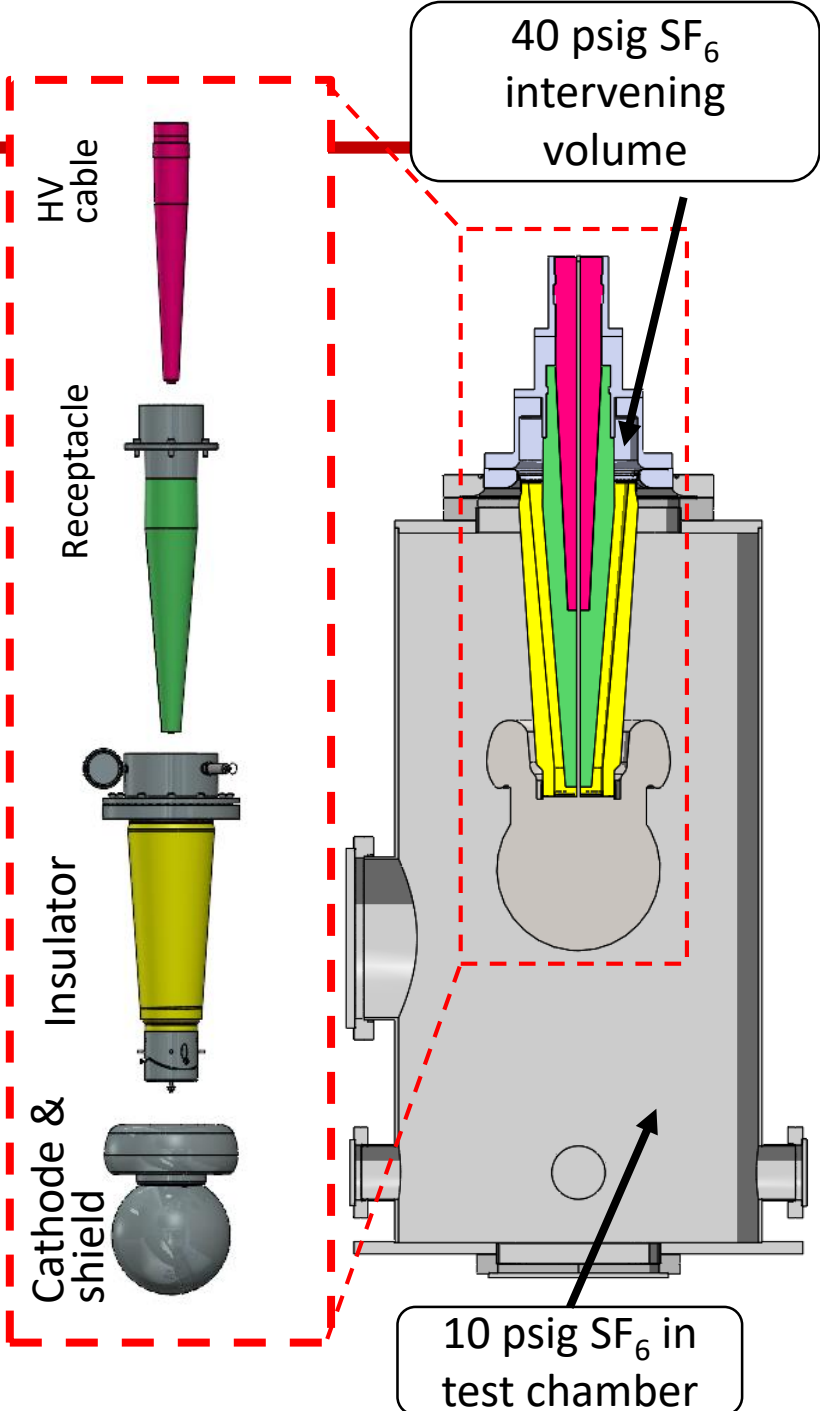

The assembled test apparatus was connected to a SF6 gas insulated Glassman 500 kV DC power supply using a high voltage cable.

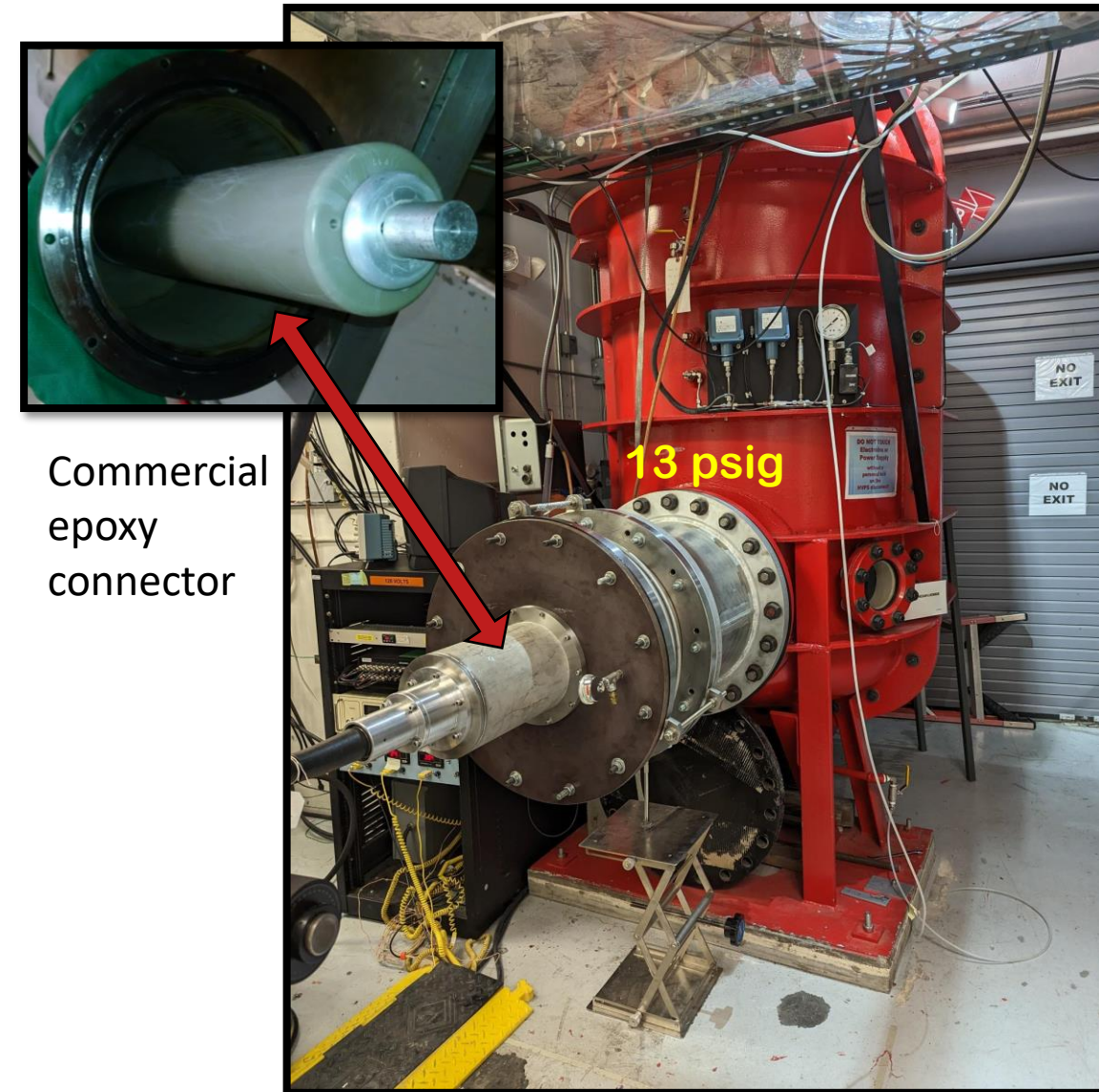

Commercial epoxy connector

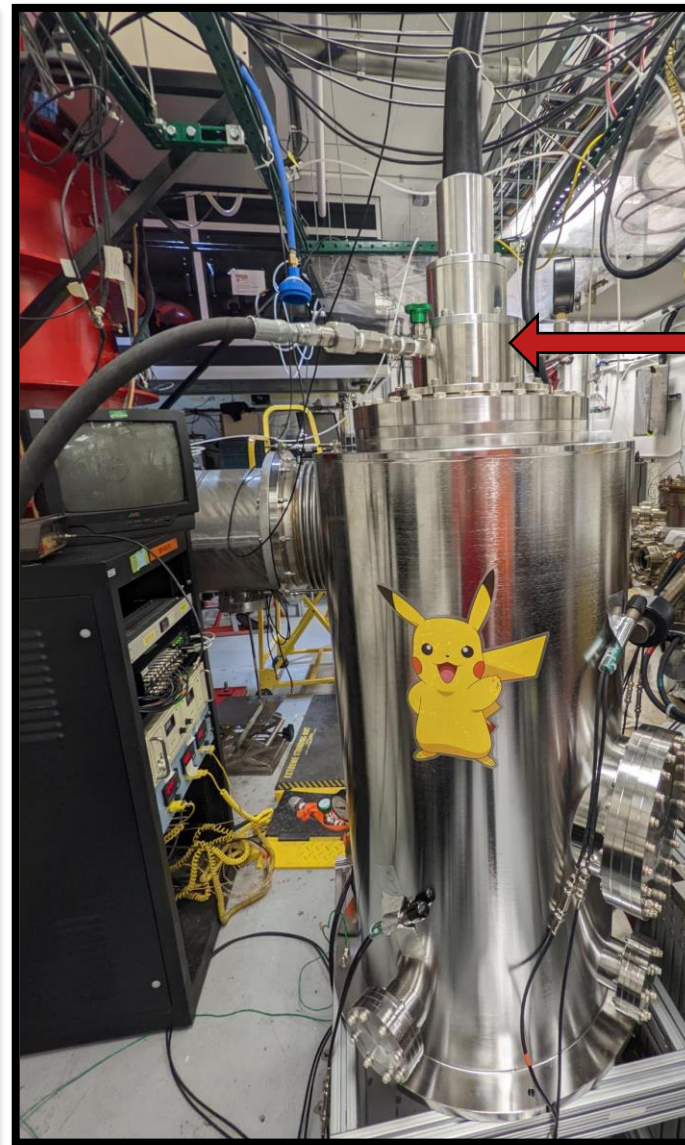

Volume between insulator and receptacle: 3.7 bar

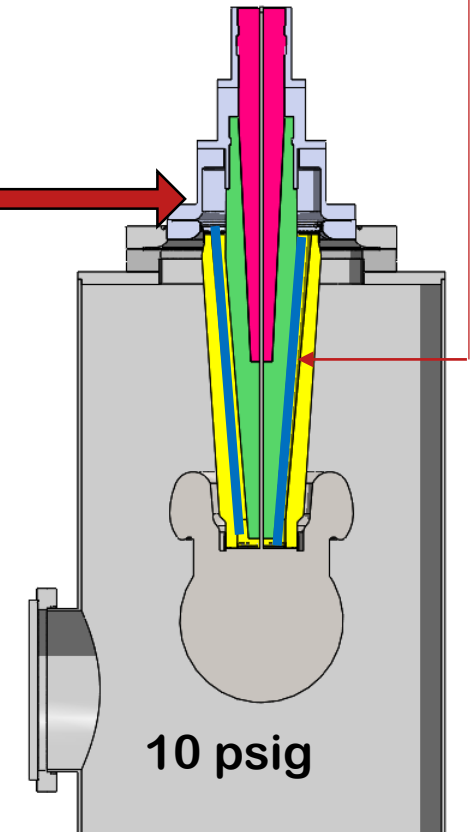

Modified commercial epoxy connector coupled to HV cable and connected to the conical insulator

Progress: High voltage test successful!

- The test chamber was filled with SF₆ gas to nominal 10 psig, the separate feedthrough reservoir containing the volume of the SF₆ intervening layer between the receptacle and the insulator was filled to 40 psig.
- The graph shows the voltage steps in blue, and the high voltage power supply current (from the internal measuring stack) in red. A couple of current peaks were observed at 500 kV until an over-current trip. The current readings are in mA.

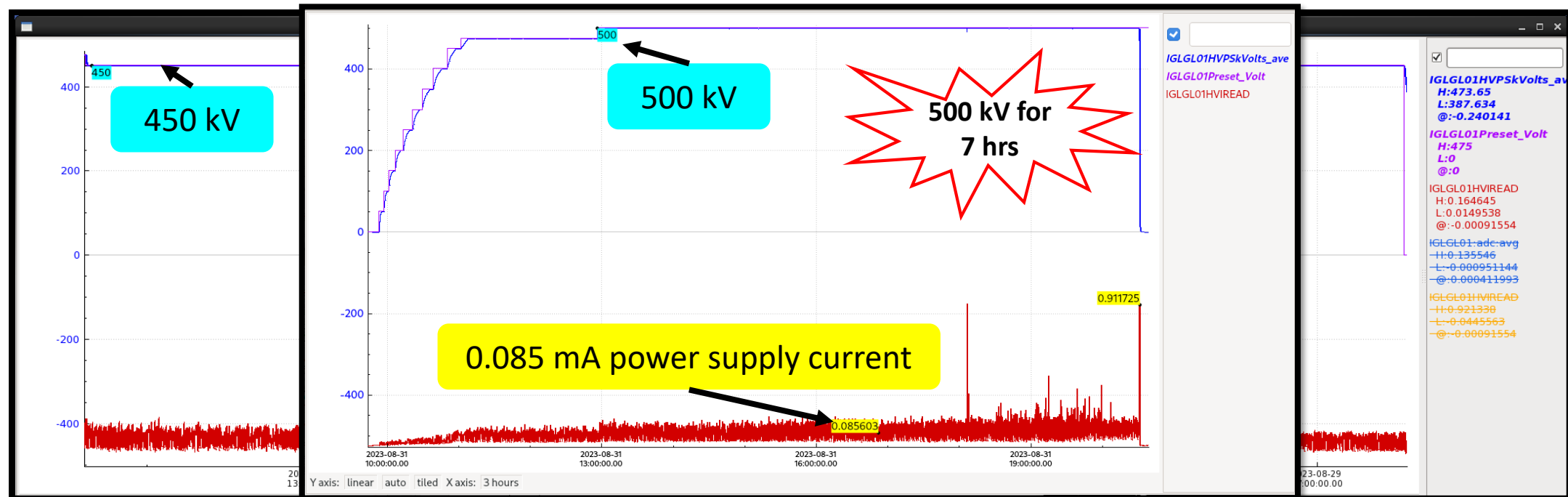

Next test will be performed under vacuum conditions in the test chamber

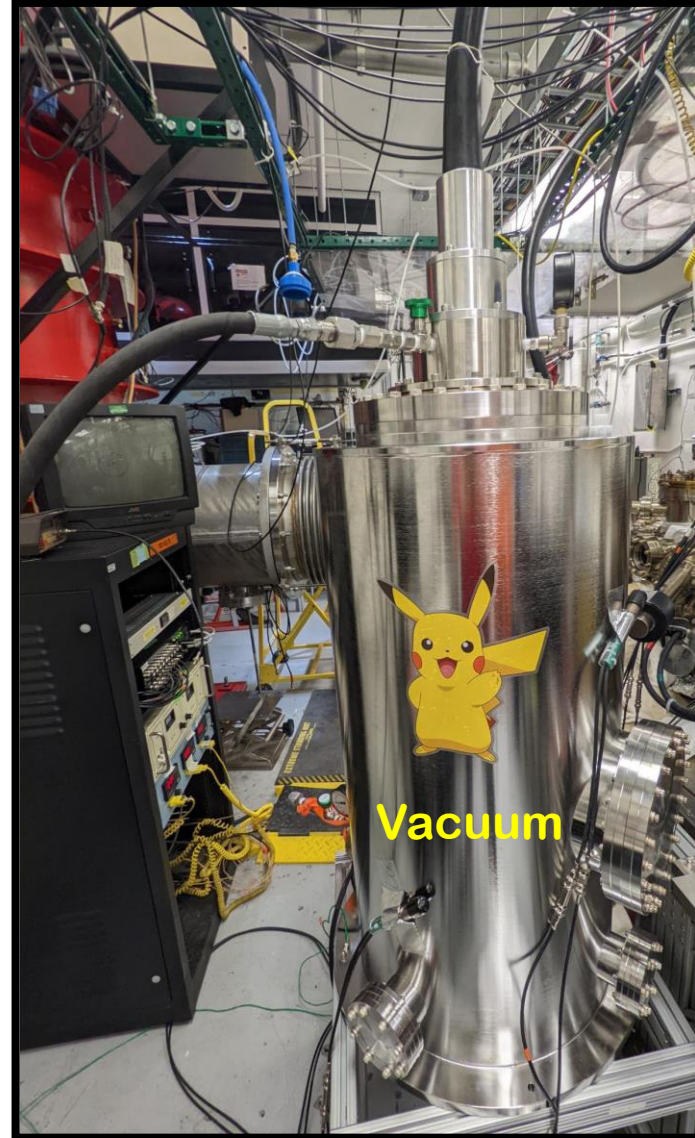
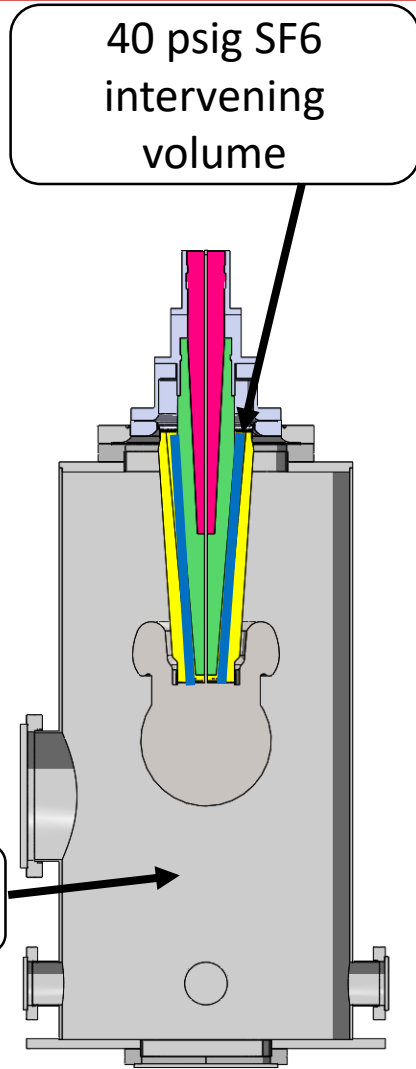

The next objective is to design and fabricate a 500 kV insulator compatible with commercial high voltage cable

Finding ceramic manufacturers capable and willing to engineer and fabricate such an insulator has been very challenging!!!

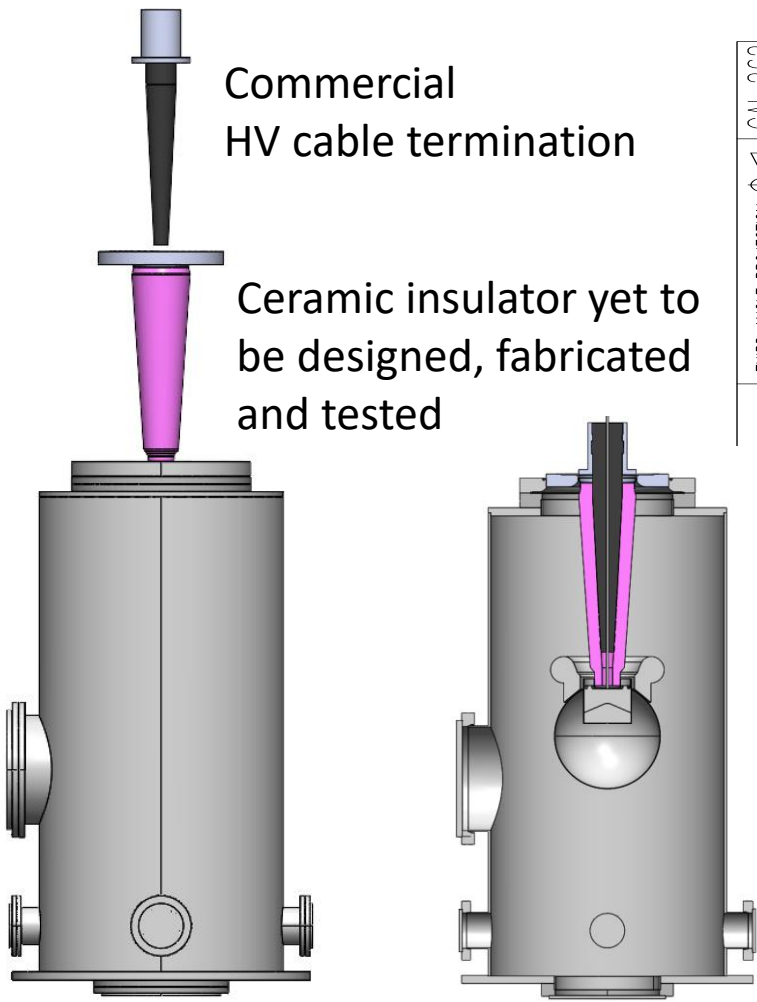

Commercial HV cable termination

Ceramic insulator yet to be designed, fabricated and tested

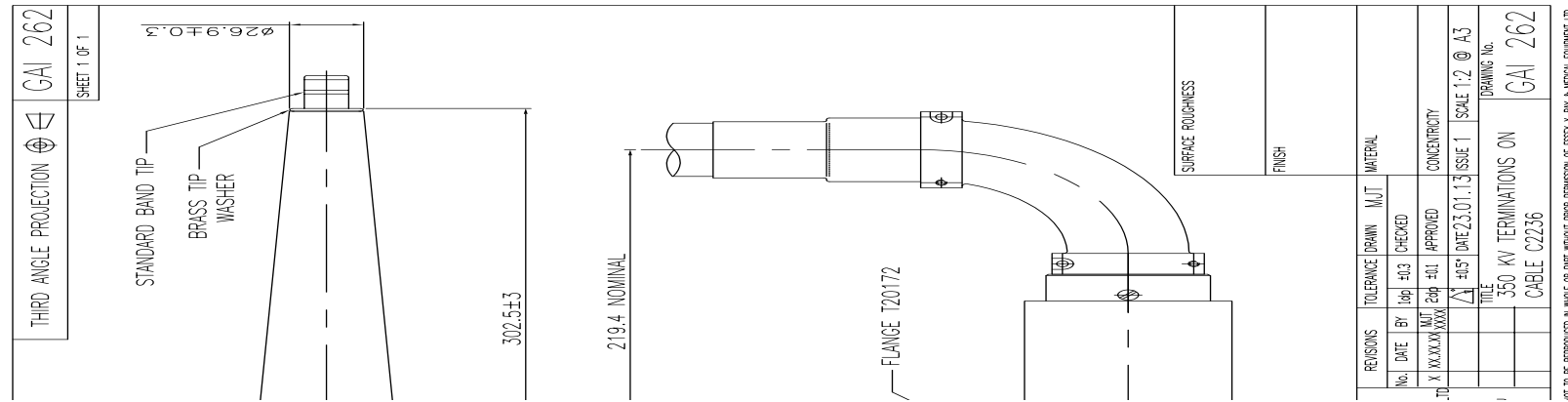

THIRD ANGLE PROJECTION
SHEET 1 OF 1
GAI 262

REVISONS	TOLERANCE	DRAWN	MJT	MATERIAL
No.	DATE	BY	LOG	CHK
1	X/XX/XX/XX	MJT	200	401
APPROVED		CONCENTRICITY		
DATE: 23.01.13		ISSUE 1		
SCALE: 1:2 @ A3		DRAWING No.		
TITLE		GAI 262		
350 KV TERMINATIONS ON		CABLE C2236		



Conclusions, and thank you for your attention!

- JLab has demonstrated custom 500 kV feedthrough with SF6 intervening volume using commercial HV cable
- Custom 500 kV feedthrough with SF6 intervening volume has yet to be tested with electrode in vacuum conditions
- Inverted geometry ceramic insulator photoguns have provided highly polarized electron beam at 130 keV and 0.2 mA CW for nuclear physics experiments at JLab for over a decade, and have demonstrated up to 300 keV and 5 mA CW un-polarized beam
- Achieving 200-300 kV operations w/o field emission in inverted insulators photoguns is still challenging
- Finding manufacturers capable and willing to engineer and fabricate custom 500 kV inverted insulator feedthroughs has been very challenging. This is slowing down progress in developing next generation of high polarization high intensity electron guns for ILC and proposed positron sources.

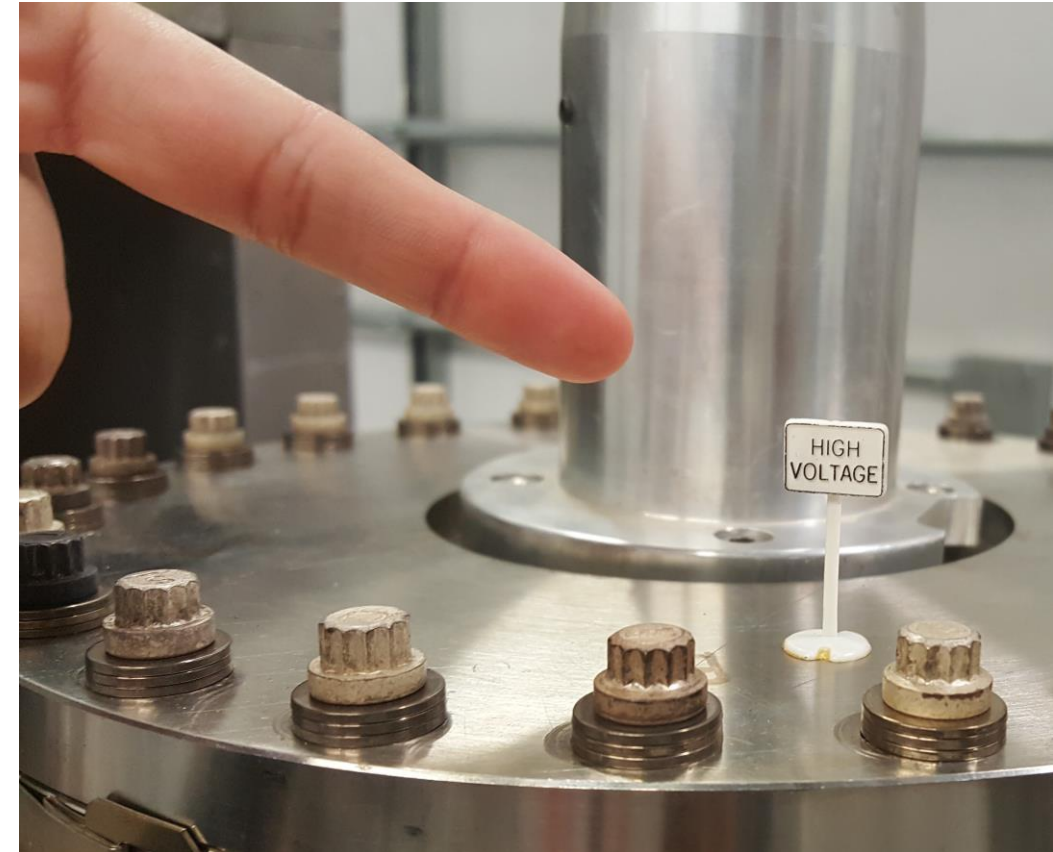

Backup slides

file name: test3

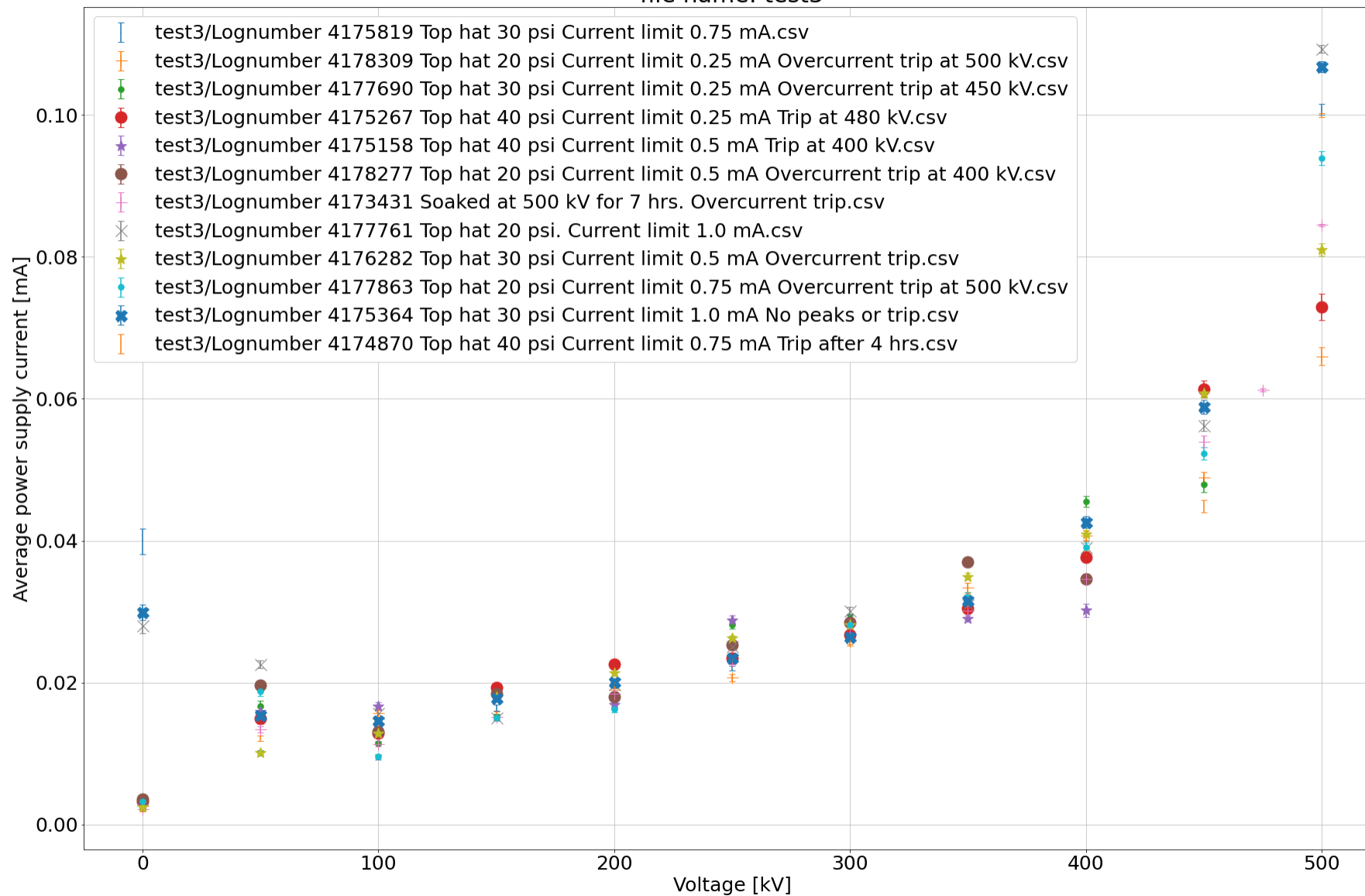

Triple junction shield design: vacuum, metal and insulator interface

To reduce risk of breakdown along the insulator:

- Minimize gradient along the insulator
- Minimize gradient at triple junction
- Make the potential along the insulator as linear as possible



To reduce risk of field emission:

- Adjust electrode size and radius to maintain 10 MV/m max at 350kV

To attain a radially symmetric electric field in the anode-cathode gap (beam dynamics):

- Keep anode-cathode gap off the line of sight to insulator

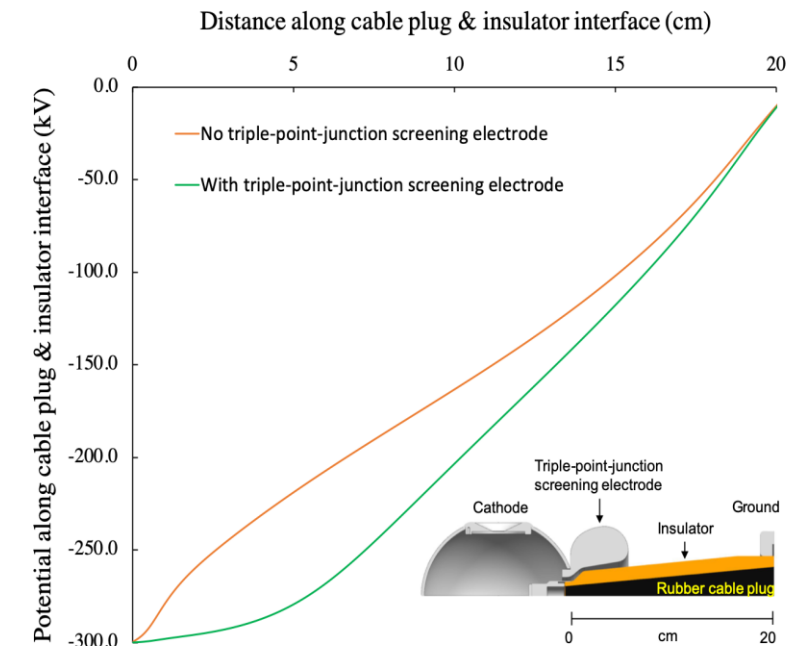
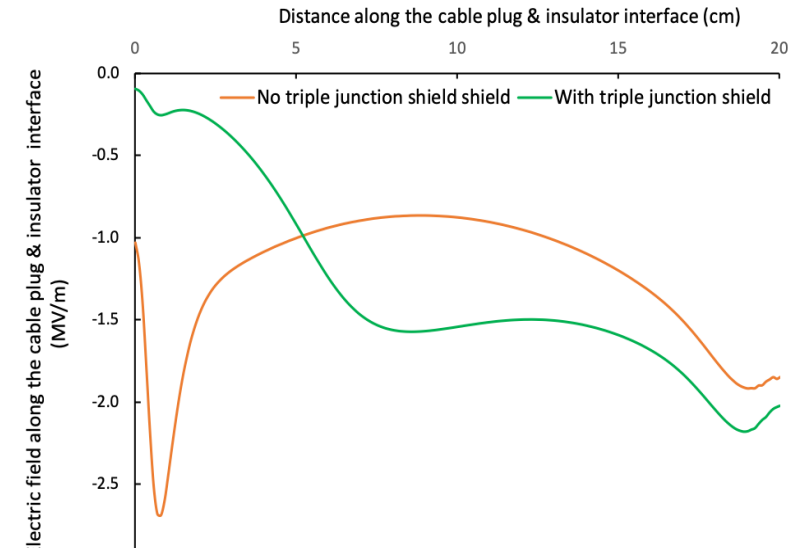
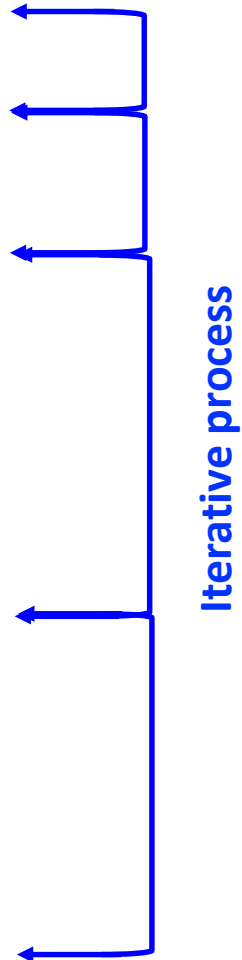

The engineering design evolved from the electrostatic optimization

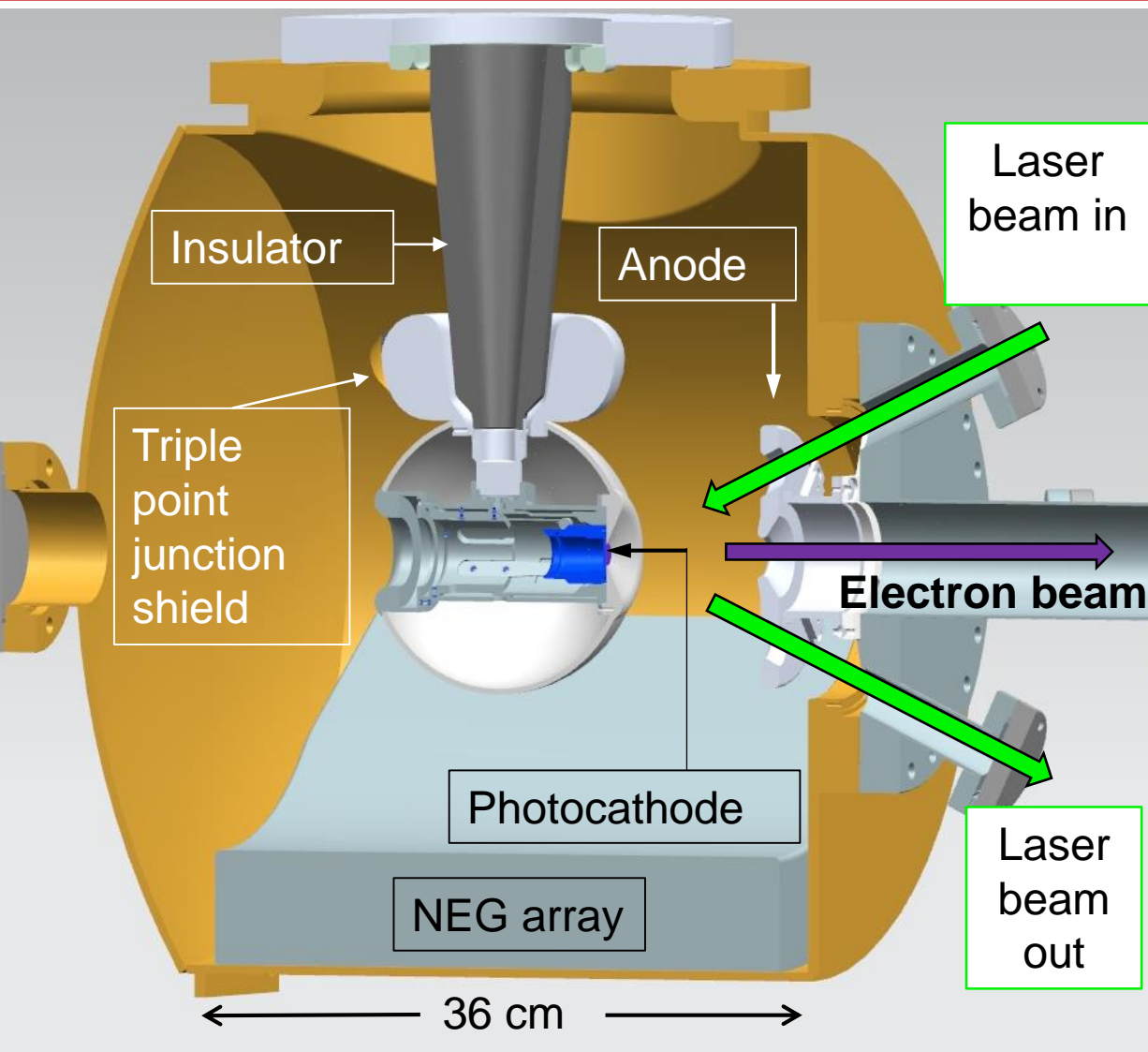

- The vacuum chamber was vacuum fired to 400° C for ~ 100 h to minimize outgassing
- The electrodes were vacuum fired at to 900° C for ~ 24 h to minimize outgassing
- The anode and mounting flange design allow for laser to illuminate the photocathode at 25°
- The ceramic insulator is doped to drain charge for minimizing arcing
- The ball cathode and triple junction shield were barrel polished in corncob to < 100 nm rms surface roughness for minimizing field emission*

The inverted-geometry insulator photogun design has a number of advantages over the large-bore insulator photogun design

- helps achieving exceptional vacuum because there is less surface area to contribute a gas load
- serves to minimize field emission because there is less metal biased at high voltage, and
- a large SF6 tank is not required at the photogun, because a high voltage cable is used to apply high voltage

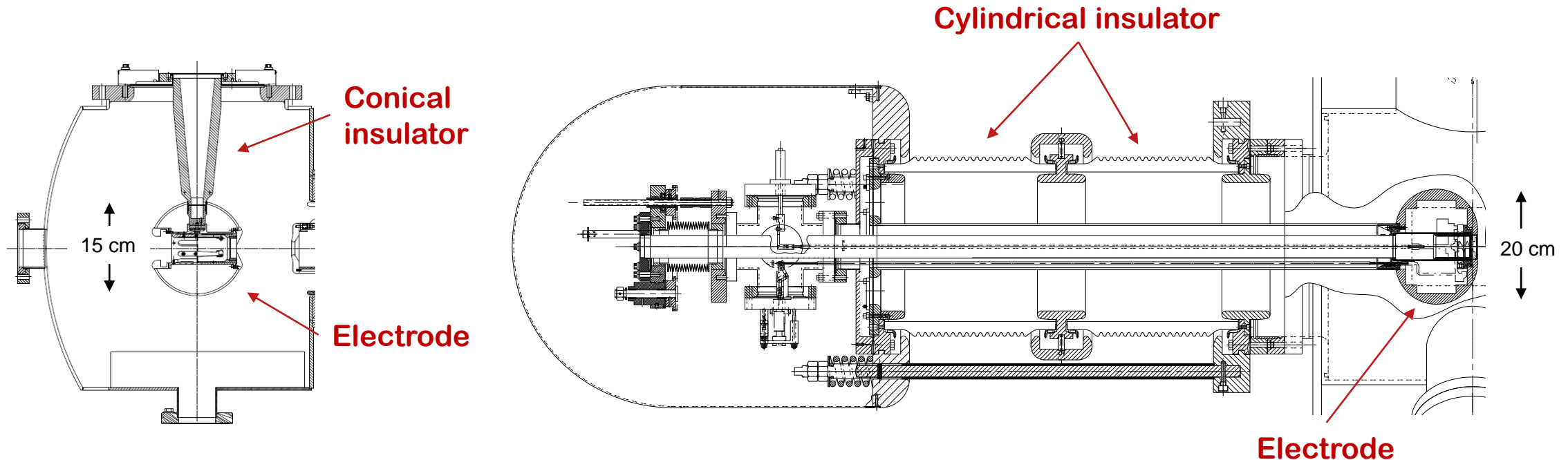

The HVPS tank and apparatus were pressurized with SF₆

- We use a commercial SF₆ gas recovery / backfill system to transfer SF₆ from the high voltage apparatus (power supply, resistor tank, test chamber) into storage bottles.
- The gas is compressed into the bottles via two compressors
- Then the SF₆ is transferred back from the storage bottles to the high voltage apparatus using a regulator integrated to the transfer system

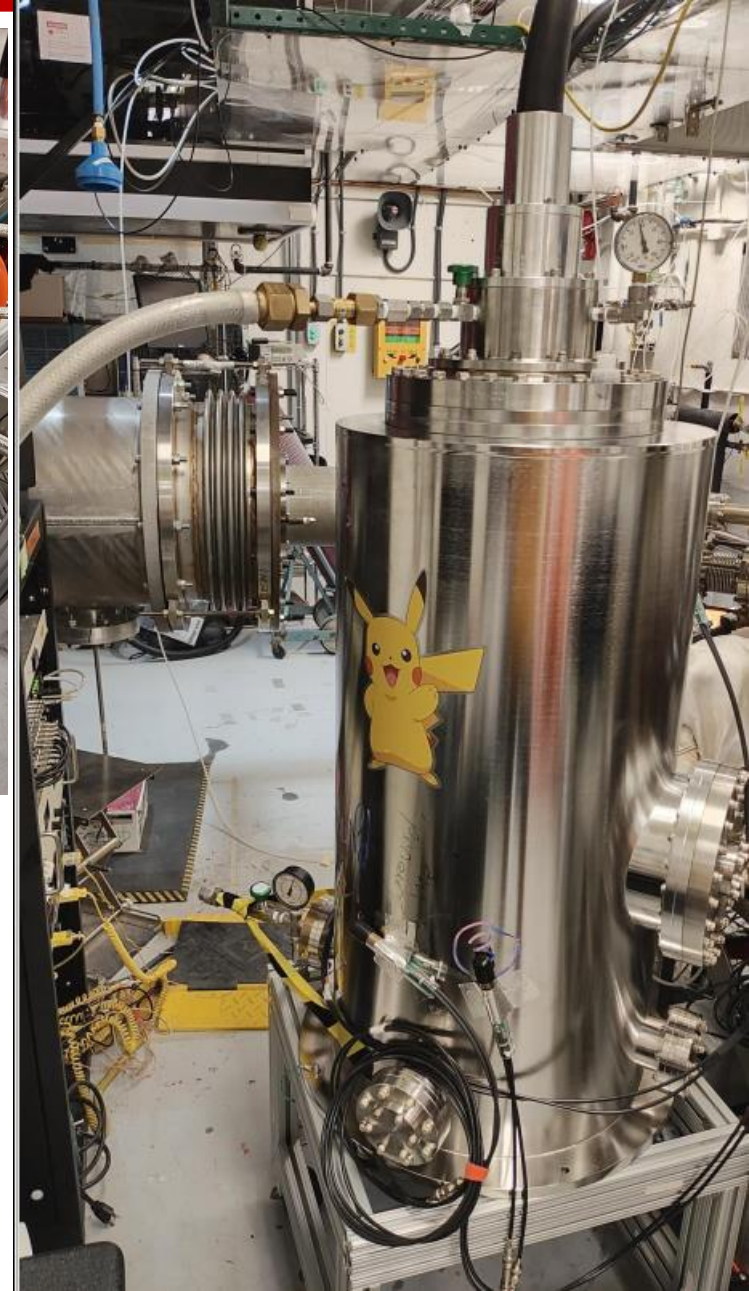

JLab has a long history developing DC photoguns

CEBAF 100-130 kV

- 1990 Thermionic gun
- 1994 First vent-bake vertical photogun [1]
- 1998 Two vent-bake horizontal guns [2]
- 1999 One vent-bake + first load-lock large bore [3]
- 2007 First load-lock with inverted insulator + one vent-bake horizontal both large bore [4]
- 2011 Upgrade load-lock [5]

FEL 320-350 kV

- 1998 FEL IR Demo
- 2001 FEL IR Upgrade 5 mA CW from GaAs
- 2005 FEL IR Upgrade 10 mA CW for 14 kV world power record
- 2012- present Semi-load lock

GTS 200-450 kV

- 2005 Vent-bake first to make 1 nC from GaAs
- 2016 Inverted insulator test
- 2017 Inverted insulator+multi-alkali 28 mA & magnetized beam
- 2019 Thermionic gun magnetized beam
- 2022 Inverted insulator high gradient cathode

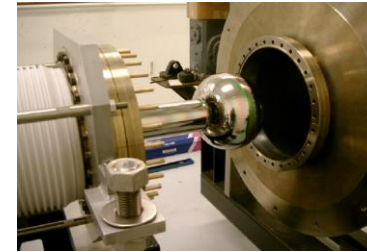
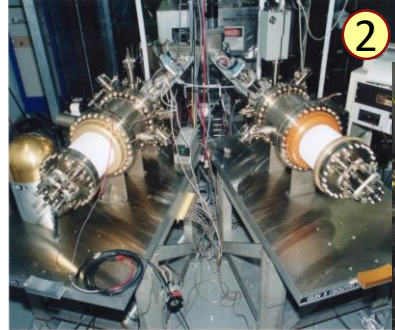
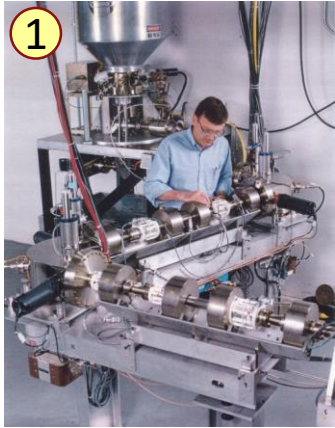

ITF->UITF

- 1994-1997 Vent-bake FEL gun test
- 1997-1999 CEBAF hor. Gun test
- 2000-2009 Load-lock gun tests large bore insulator, then inverted insulator
- 2011 Inverted gun with Nb at 225kV
- 2012 – present inverted guns with shielding electrodes

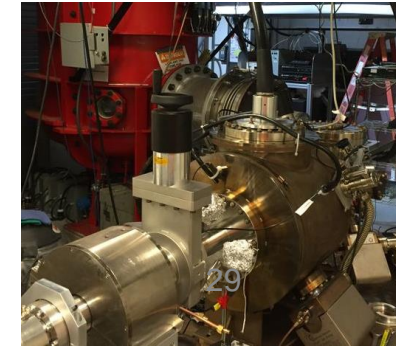
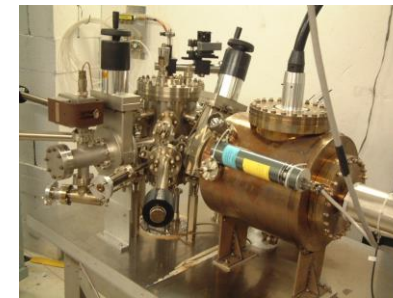
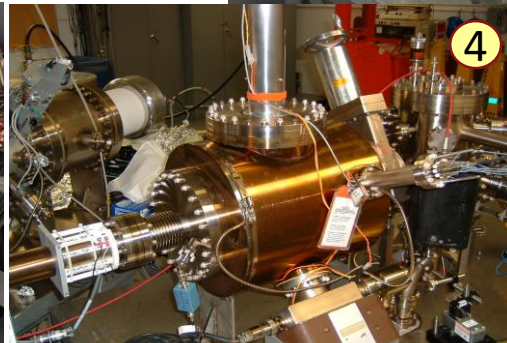
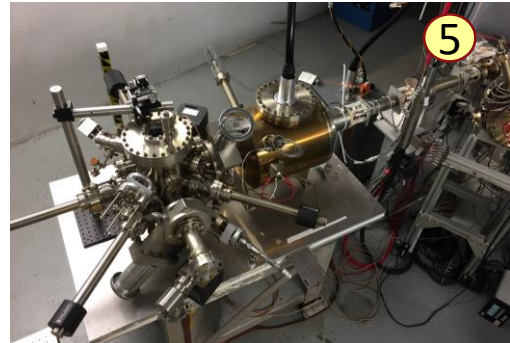
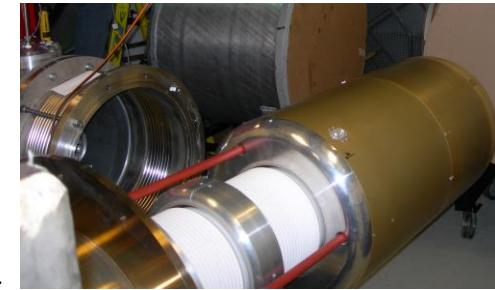
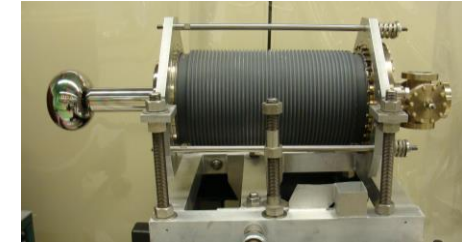

Multiple electrodes have been tested & used for beam

CEBAF
100 –
180 kV

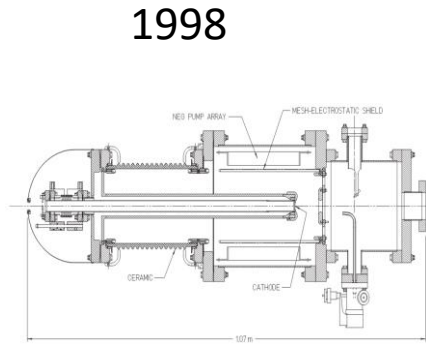
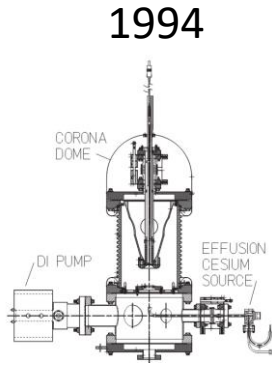

1999-2011

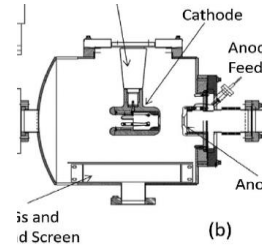

2011-2018

Tee no shed



100-130kV
Beam ops

2018-19

Large shed



200kV + some
beam + FE

9/2019

Small shed



100kV FE onset
Could not Kr HV proc.

2019-present

Tee no shed



130kV
Beam ops

ITF

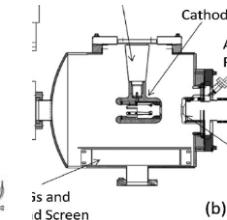
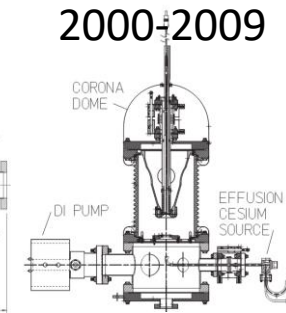
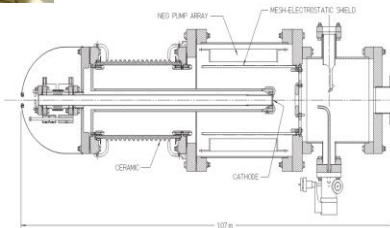

UITF
200 kV

11/2017-5/2018



220 kV in vacuum + FE
227kV Kr HV + FE
200 keV beam ops + FE

4/2019



220kV Kr HV no F.E.
Then FE @ 170kV

8-10/2019



10/2019-present



Re-polished
150kV onset FE
225 kV Kr HV + FE
200keV beam +FE

GTS 350 kV
2005-2015



2016-present up to 350 kV

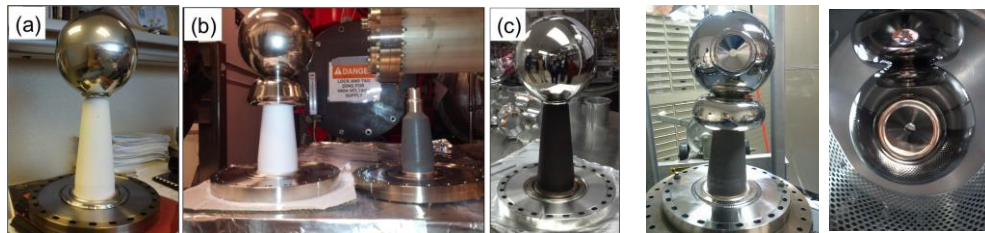

FEL 350 kV
1997-present
Multiple electrodes
like this one

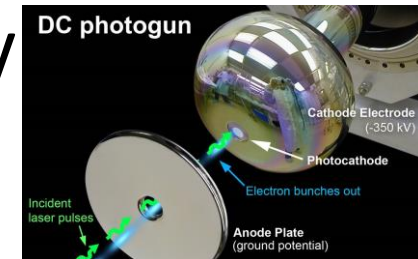

The large inverted insulators were made back in 2010 for a 500 kV inverted insulator photogun concept to be connected directly to the HVPS

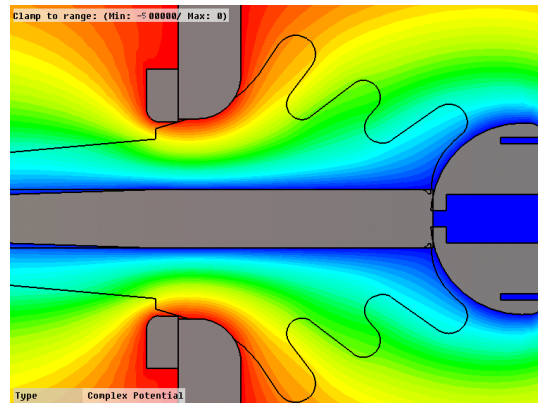
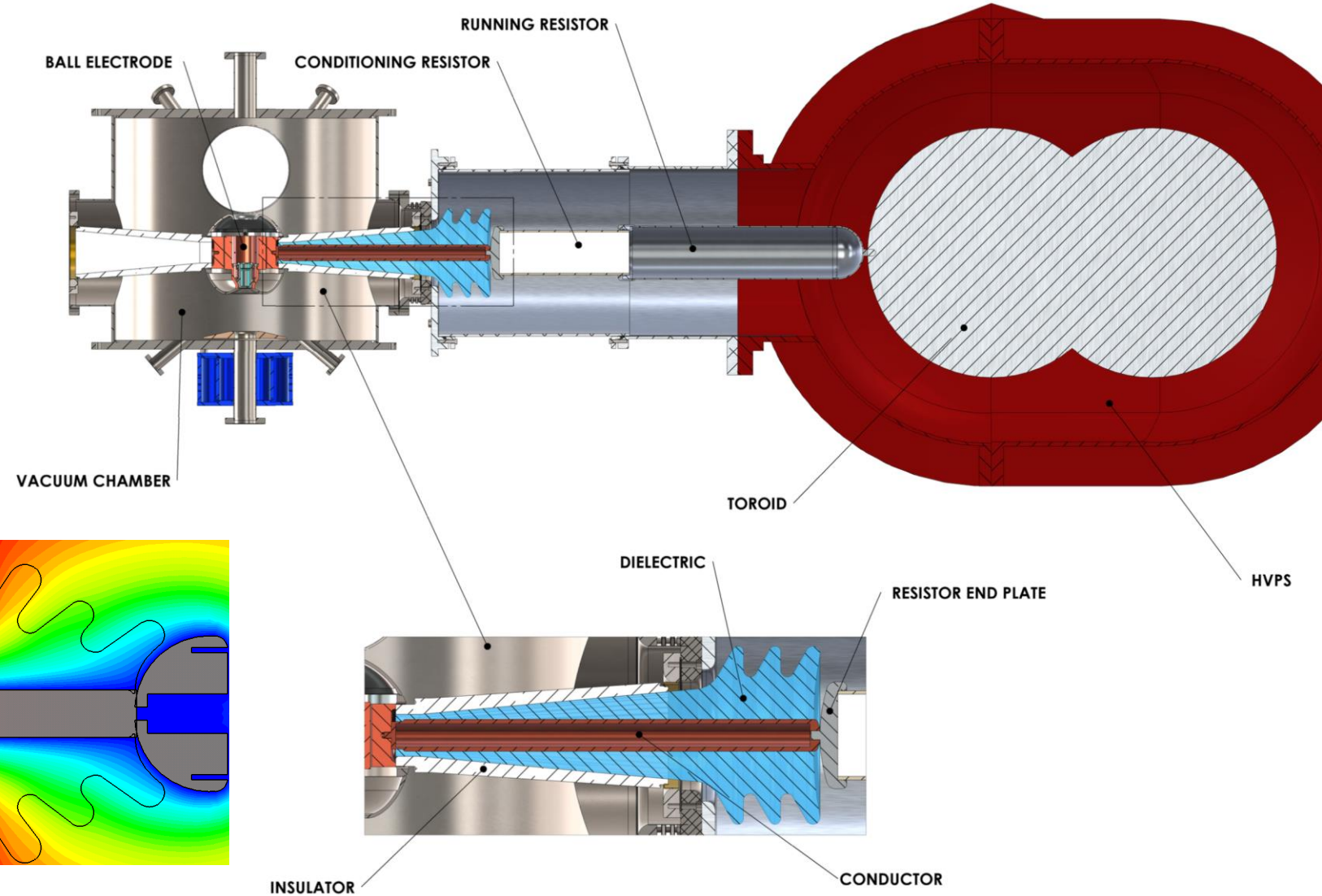

F. E. Hannon, P. Evtushenko, and C. Hernandez-Garcia, "Electrostatic modeling of the Jefferson Laboratory Inverted Ceramic Gun", Proceedings of the International Particle Accelerator Conference **2010**

