

Tevatron Top Quark Forward-Backward Asymmetry Implications for Same-sign Top Quark Pair Production at the LHC

Berger, Q-H Cao, C-R Chen, C-S Li, and H Zhang
arXiv:1101.5625 (Phys Rev Lett 106, 201801 (2011))

Color Sextet Mesons and Same-Sign Top Quark Pairs at the LHC

Berger, Q-H Cao, C-R Chen, G Shaughnessy, H Zhang
arXiv:1005.2622 (Phys Rev Lett. 105, 181802 (2010))
arXiv:1009.5379 (Phys Lett B696, 68 (2011))

Standard model charge asymmetry

★ Charge asymmetry in QCD at NLO

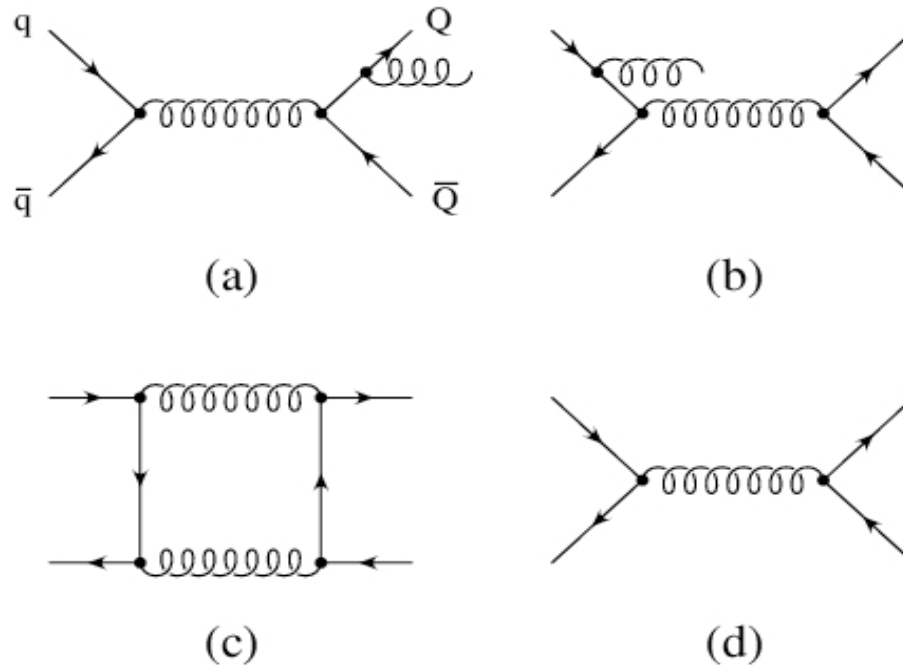

Top quarks are produced along the direction of the incoming quark

$$A^{p\bar{p}} = \frac{N_t(y > 0) - N_{\bar{t}}(y > 0)}{N_t(y > 0) + N_{\bar{t}}(y > 0)} = 0.051(6)$$

Antunano, Kühn, Rodrigo
Phys. Rev. D77, 014003 (2008).

$$A^{t\bar{t}} = \frac{N(\Delta y > 0) - N(\Delta y < 0)}{N(\Delta y > 0) + N(\Delta y < 0)} = 0.078(9) \quad \Delta y = y_t - y_{\bar{t}}$$

CDF measurement

arXiv:1101.0034 5.3 fb⁻¹

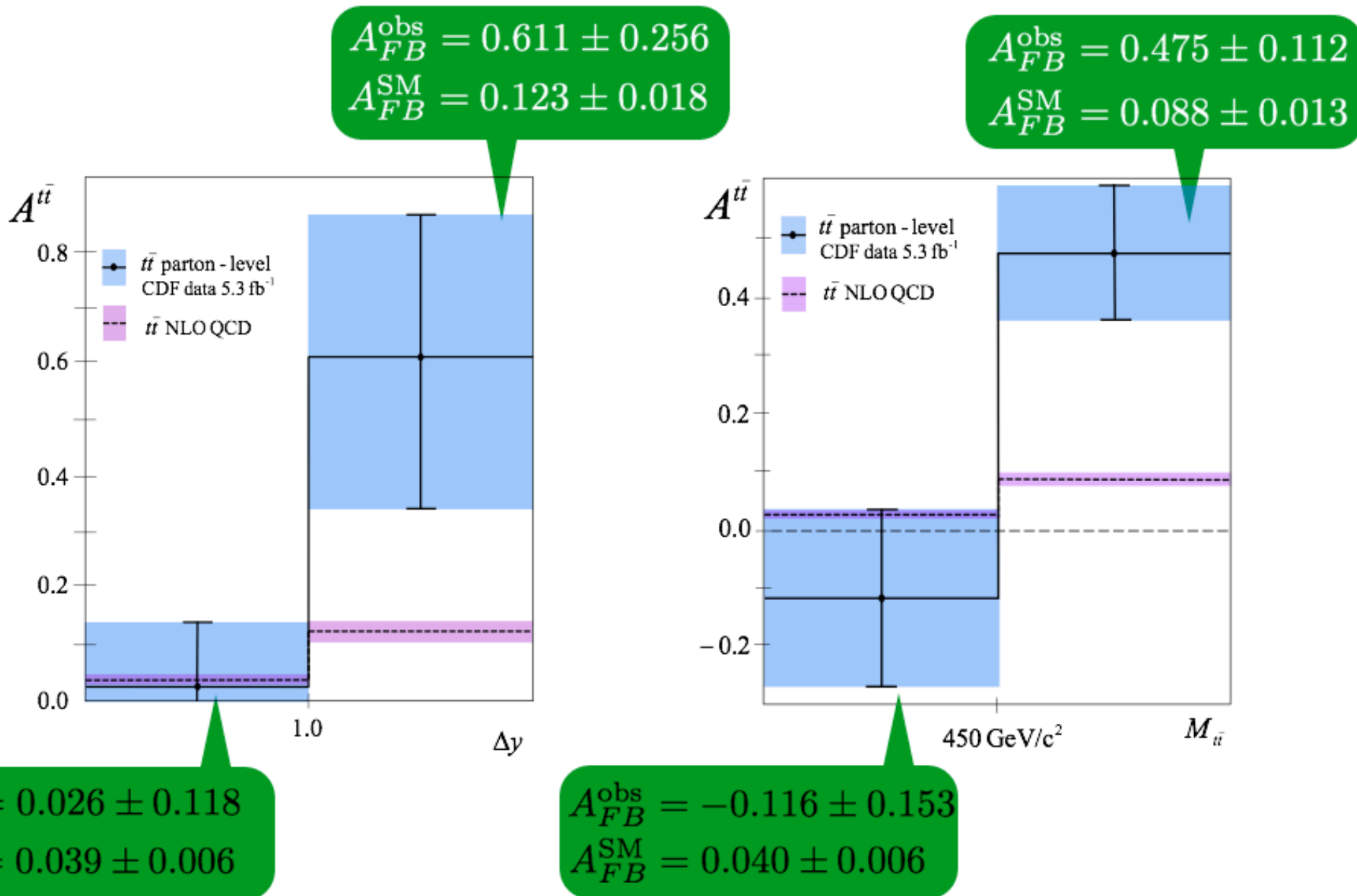

- Use MC@NLO event generator, with HERWIG showering to model $t\bar{t}$ event distributions -- includes the predicted SM/QCD asymmetry
- **Asymmetry unfolded for acceptance and detector resolution**
 $A_{\text{FB}} = 19.6 \pm 6.5 \%$ versus $5.0 \pm 0.1 \%$ in MC@NLO
- Asymmetry results confirm excess with respect to QCD, **but**
- No significant increase of A_{FB} with rapidity separation or with invariant mass, **and**
- Transverse momentum spectrum of the $t\bar{t}$ system is softer in data than in MC@NLO

New physics models

★ NP models may be divided into two classes

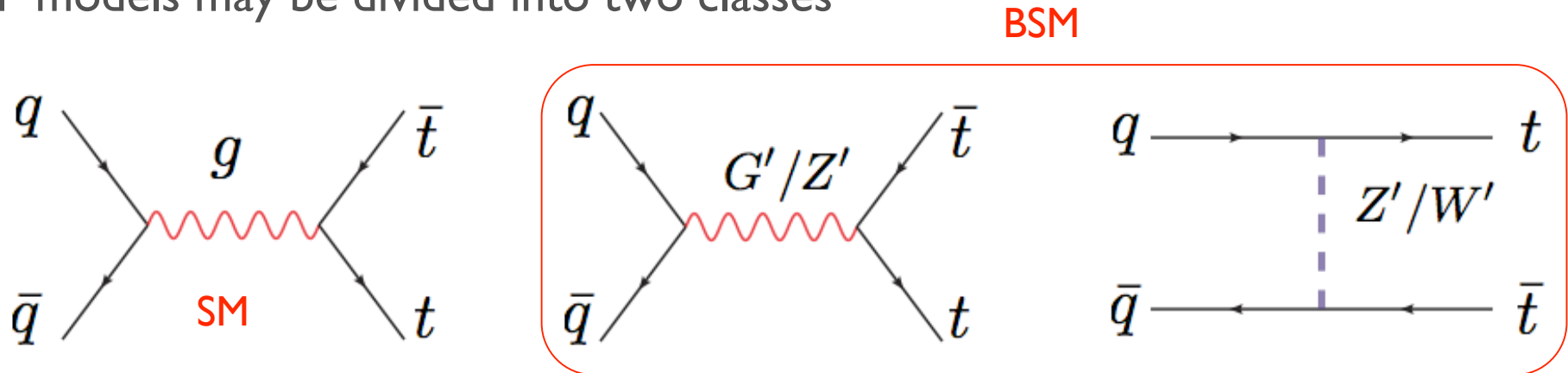

s-channel: extra octet vector gluon (axigluon,?)

small couplings to the first two generations: dijet constraints at 7 TeV

large couplings to third generation: to generate large A_{FB}

heavy resonances: $t\bar{t}$ invariant mass spectrum constraints

broad width: to interfere with the SM amplitude

t-channel: flavor changing interaction

color singlet: $Z' - u - t$ (ϕ -u-t)

color sextet or triplet

$W'^+ - d - t$ (ϕ^+ -d-t)

What can one say about the FCNC Z' model at 7 TeV (or at the Tevatron)?

Non-universal FCNC Z-prime model

$$\mathcal{L} = g_W \bar{u} \gamma^\mu (f_L P_L + f_R P_R) t Z'_\mu + h.c.$$

Left-handed coupling is highly constrained by $\bar{B}_d - \bar{B}_d$ mixing.

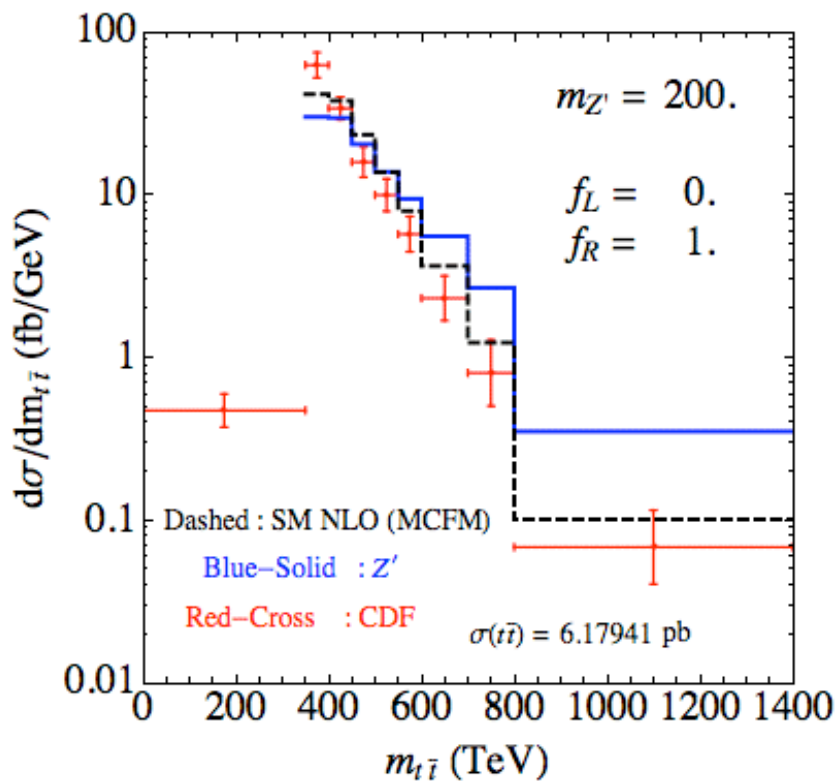

Use Tevatron A_{FB} data to determine right-handed FCNC coupling f_R

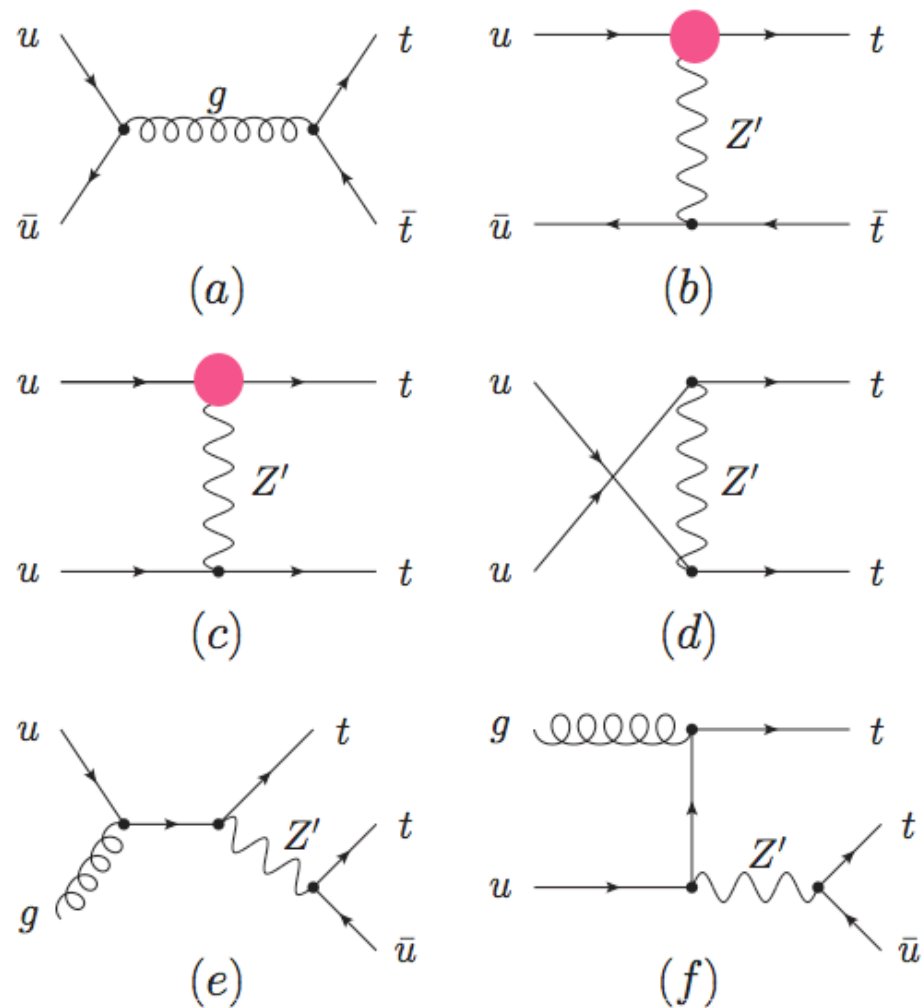

Tevatron Constraints

- ★ Fit to the CDF data includes SM, New Physics (NP), and Interference terms.
- ★ The inclusive cross section for $t\bar{t}$ pair production has been measured accurately. Its agreement within errors with SM expectations **limits the right handed coupling f_R from above.**

$$\sigma(t\bar{t}) = 7.50 \pm 0.48 \text{ pb}$$

- ★ The $t\bar{t}$ invariant mass spectrum, both normalization and shape, also imposes an **upper bound** on NP models.

- ★ Large A_{FB} **bounds f_R from below.**

$$A_{\text{FB}} = 0.475 \pm 0.114$$

- ★ The negative search for **same-sign** top quark pair at Tevatron also limits the NP parameter space -- eliminates part of the otherwise allowed region.

$$\sigma(tt + \bar{t}\bar{t}) < 0.7 \text{ pb}$$

FCNC Z-prime implications

- ★ Same-sign top quark pair production in $u u$ scattering at the Tevatron and LHC

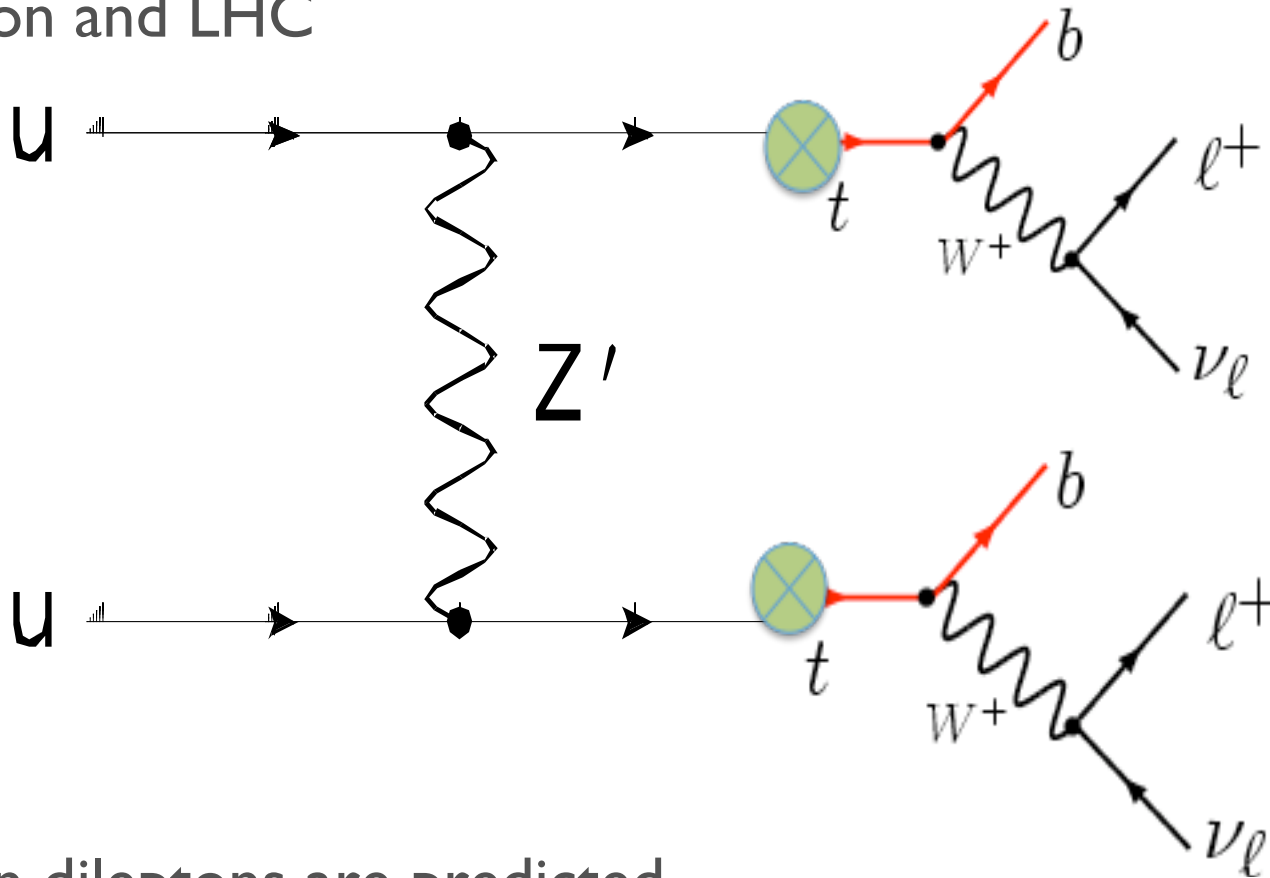

Same-sign dileptons are predicted.

- ★ Shows the 2 b, 2 lepton, and missing energy final state simulated

- ★ The same sign top quark pair cross section grows as f_R^4 .

Same-sign top pair production

Flavor Changing Z' Model -- LHC Predictions

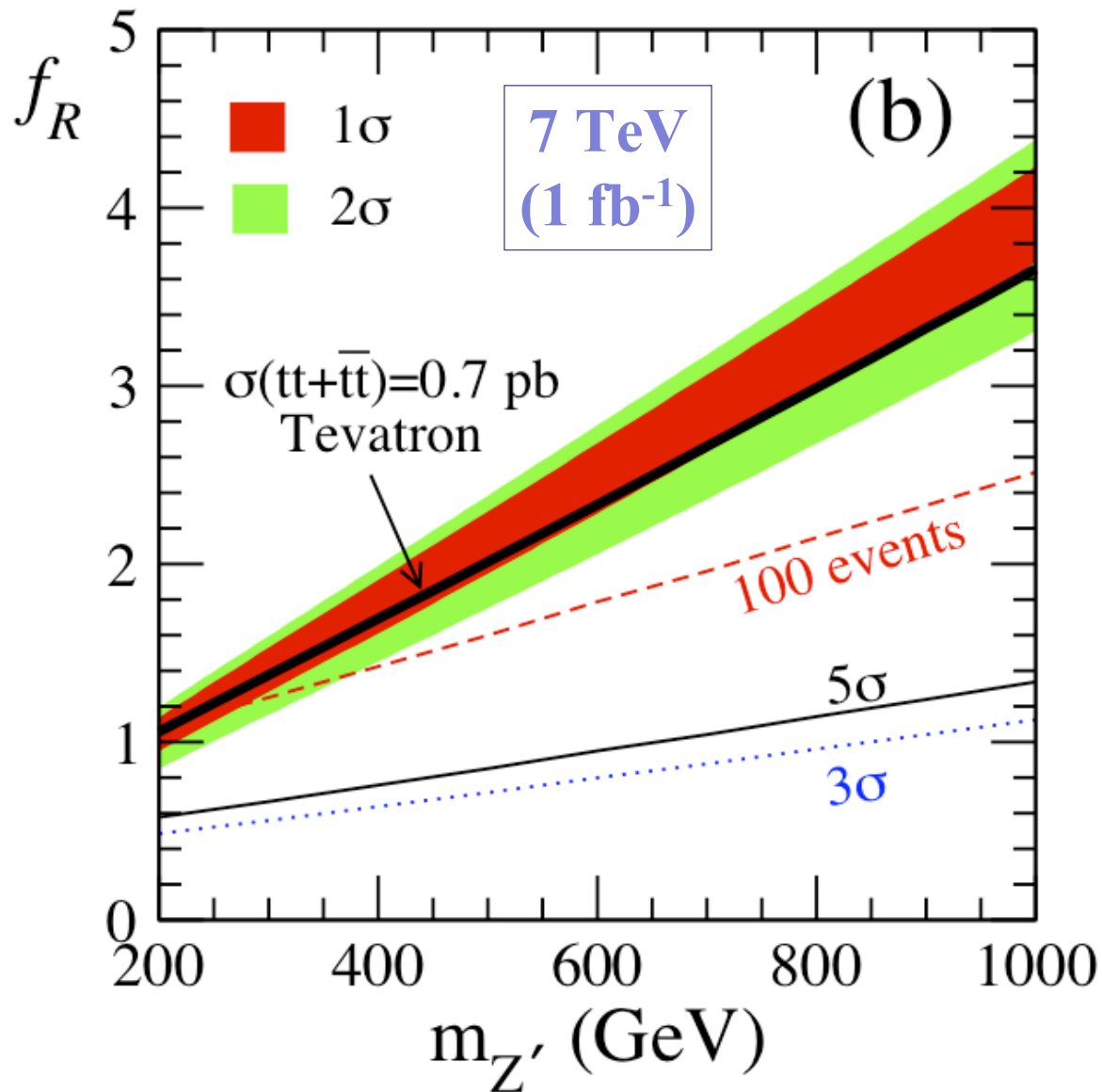

Bands show the 1 σ and 2 σ fits to the $t\bar{t}$ inclusive cross section and A_{FB} .

Parameter region of right-handed coupling f_R and Z' mass to fit A_{FB} is above the LHC 5 σ discovery curve.

LHC 7 TeV measurements would impose hard constraints on f_R . Search for same-sign top quark pairs is interesting in other model contexts also.

Tevatron same sign top quark pair production

- $\sigma(tt + \bar{t}\bar{t}) < 0.7$ pb for a cut acceptance of 0.50%
- $\sigma(tt + \bar{t}\bar{t}) < 1.4$ pb for a cut acceptance of 0.25%

CDF, Phys.Rev.Lett.102:041801 (2009)

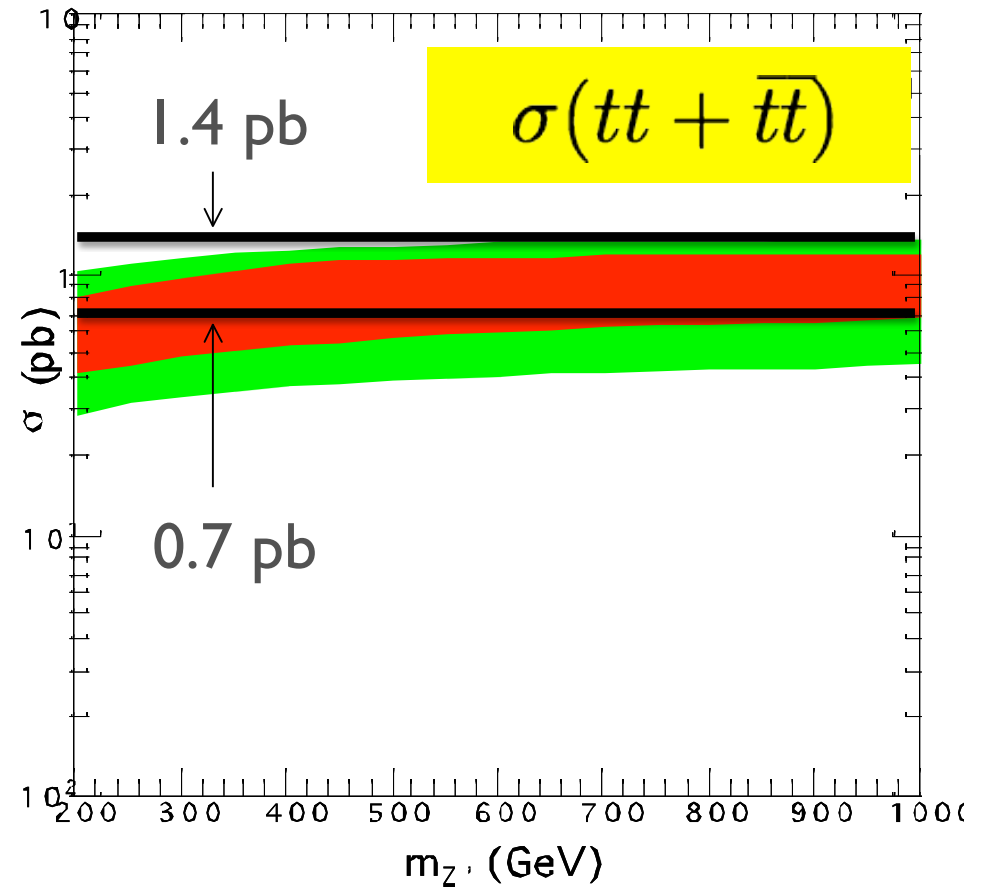
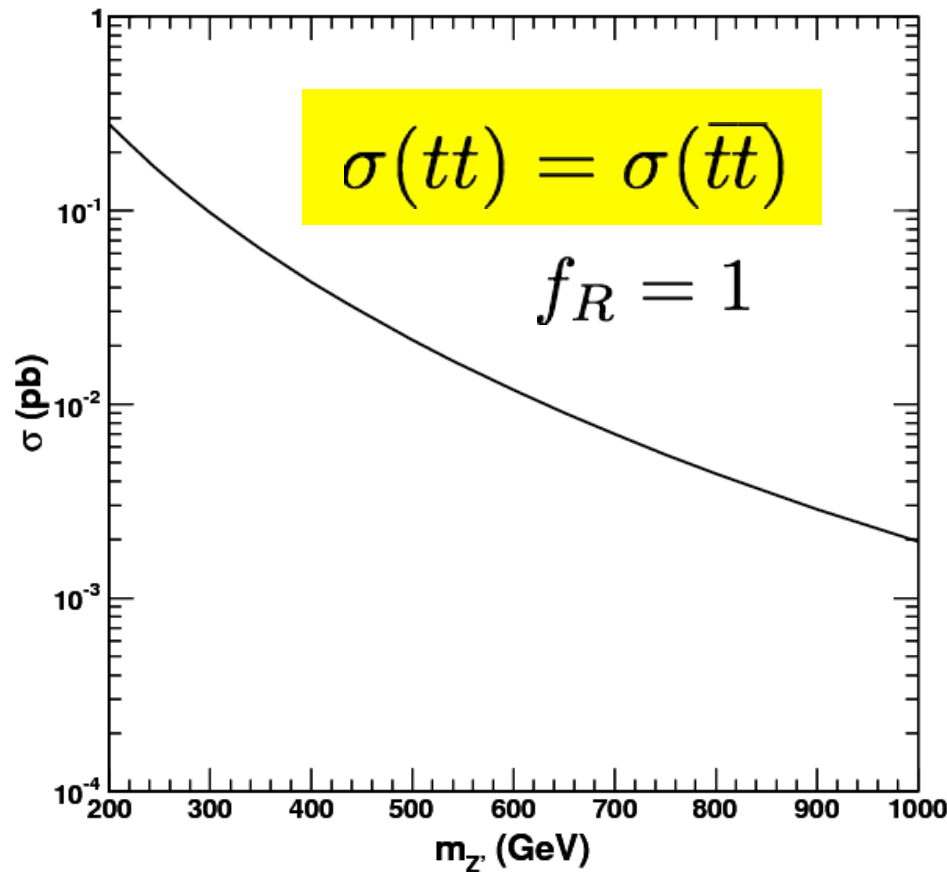

For a cut acceptance of 0.50%, part of parameter space is not allowed.

CMS search for same-sign top quark pairs

CMS $L_{\text{int}} = 35 \text{ pb}^{-1}$, $\sqrt{s} = 7 \text{ TeV}$ arXiv:1106.2142, June '11

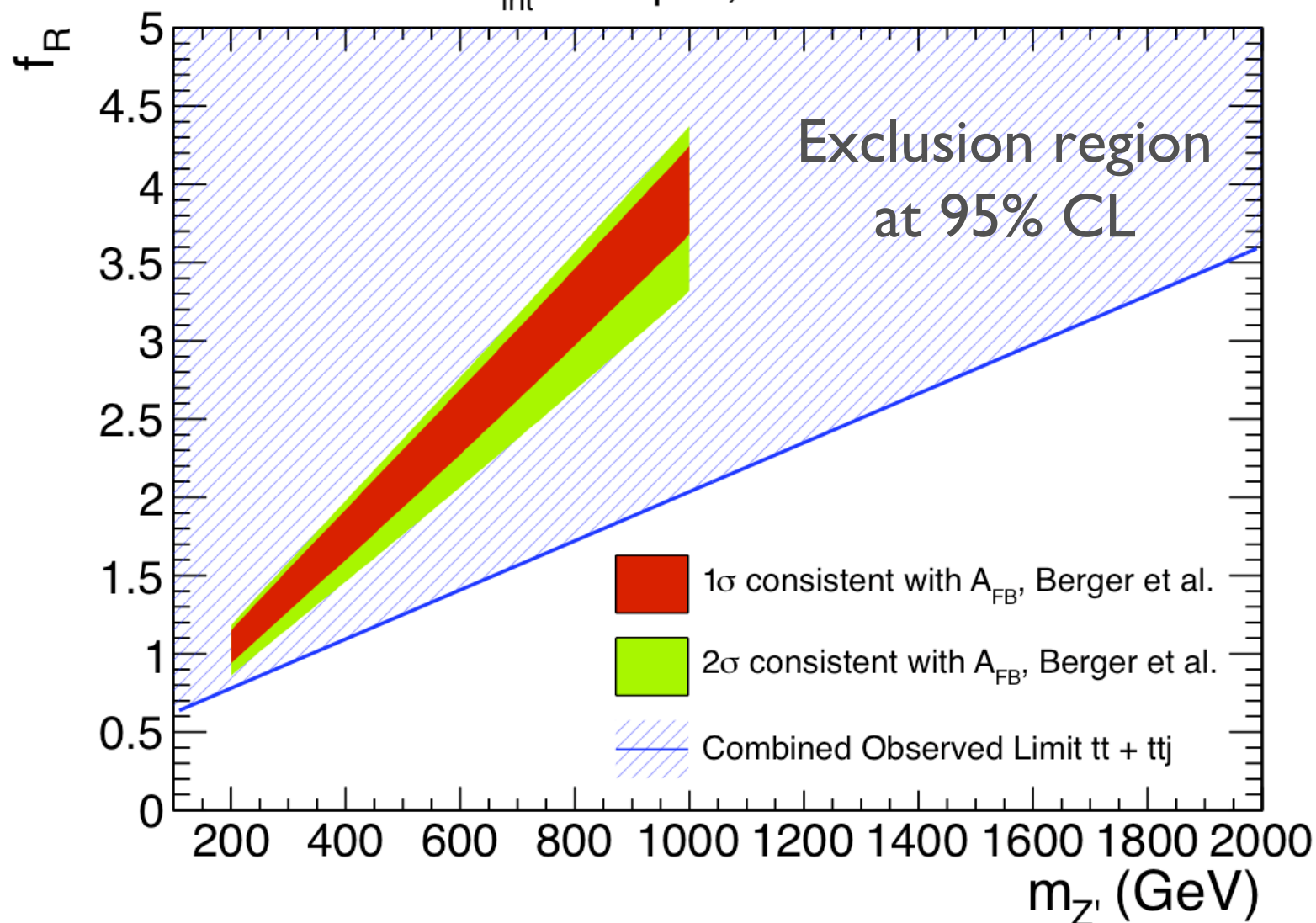

Z-prime exchange **alone** cannot explain Tevatron A_{FB}

Top quark polarization is sensitive to NP

- ★ Top quark: the only “bare” quark one can measure in the Lab
- ★ Top quark spin info is retained in the top quark decay products.
- ★ Polarization correlates with the angle between top quark spin and the charged lepton momentum:

$$\frac{1}{\Gamma} \frac{d\Gamma(t \rightarrow b\ell\nu)}{d\cos\theta} = \frac{1}{2} \left(1 + \frac{N_+ - N_-}{N_+ + N_-} \cos\theta \right)$$

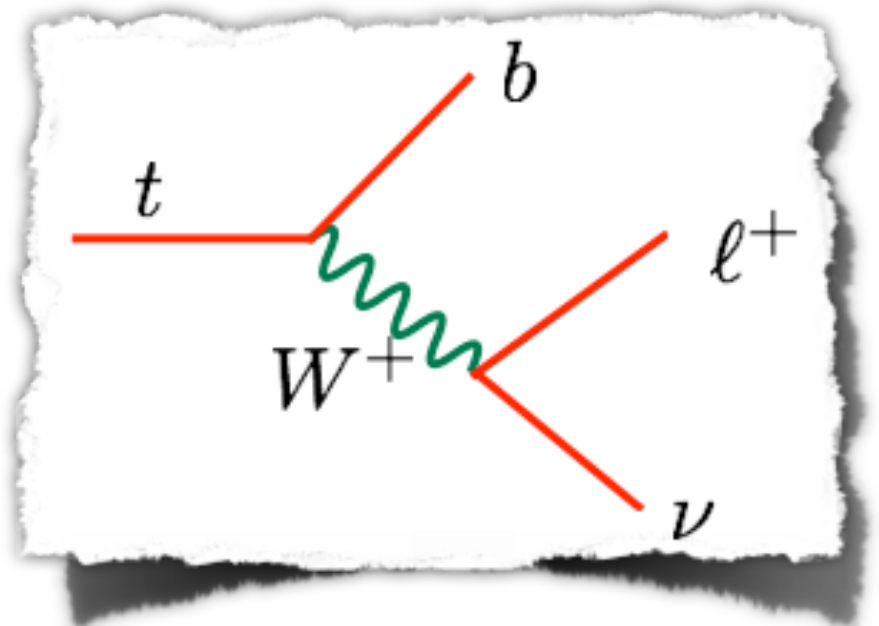

- * Charged lepton follows the top quark spin direction.

Polarization test of the FCNC Z-prime model

- ★ No resonance appears in the top quark pair invariant mass spectrum
- ★ Top quark polarization would provide additional information.

$$\mathcal{L} = g_W \bar{u} \gamma^\mu (f_L P_L + f_R P_R) t Z'_\mu + h.c.$$

Left-handed coupling is highly constrained by $\bar{B}_d - \bar{B}_d$ mixing.

Top quarks are right-handed.

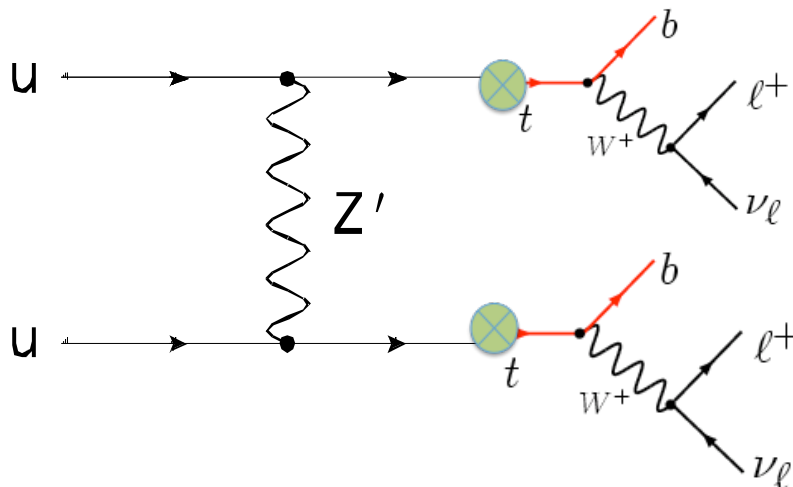

Full event reconstruction is needed to determine the top quark polarization.

Top quark polarization

- ★ Polarization correlates with the angle between top quark spin and the charged lepton momentum:

$$\frac{1}{\Gamma} \frac{d\Gamma(t \rightarrow bl\nu)}{d\cos\theta} = \frac{1}{2} \left(1 + \frac{N_+ - N_-}{N_+ + N_-} \cos\theta \right)$$

- * Charged lepton follows the top quark spin direction.
- * In the FCNC Z-prime model, the right-handed top quark yields $\frac{1}{2}(1 + \cos\theta)$

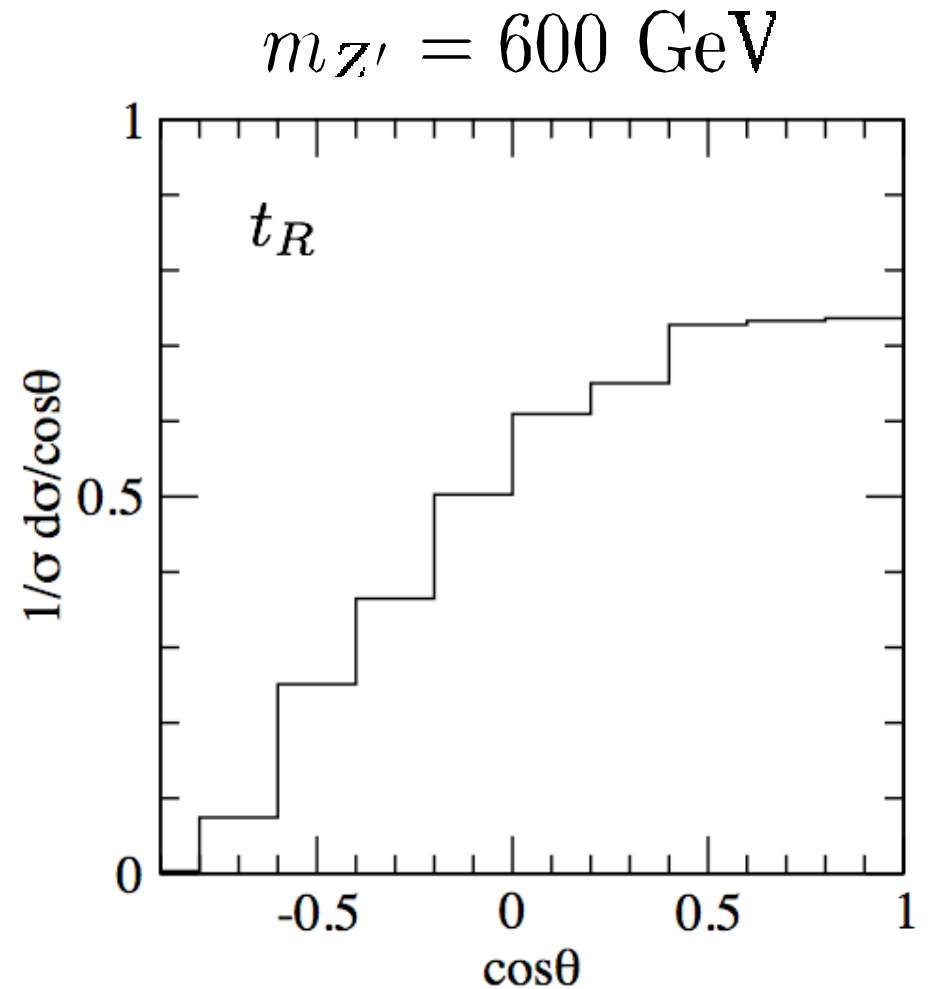

Figure shows the results of a full simulation, with cuts

Summary: Tevatron A_{FB} data and LHC Test

- ★ Among NP explanations of the top quark A_{FB} , a FCNC Z-prime is attractive as it can generate a large asymmetry without structure in the $t\bar{t}$ invariant mass spectrum.
- ★ Fit A_{FB} and the $t\bar{t}$ inclusive cross section to extract coupling f_R
- ★ FCNC interaction leads to same-sign top quark pair production at the LHC and the Tevatron
- ★ CMS search for same sign tt , based on 35 inverse pb, excludes f_R large enough to explain the Tevatron asymmetry data
- ★ FCNC Z-prime model alone cannot explain the A_{FB} data
- ★ Top quark polarization measurement is important and doable

Backup Slides

NNLO QCD corrections

★ Calculation of the complete NNLO QCD corrections is highly desirable

* NLO corrections to $t\bar{t}$ + jet (real emission terms)

(Dittmaier, Uwer, Weinzierl, 2007; Melnikov, Schulze, 2010)

* NLL threshold resummation effects (Almeida, Sterman, Vogelsang, 2008)

* NNLL threshold resummation: asymmetry does not grow at $O(\alpha_s)$

(Ahrens, Ferroglia, Neubert, Pecjak, Yang 2010)

★ Corrections to inclusive asymmetry at NNLO are not known.

★ NLO is implemented in an event generator, MC@NLO, including spin correlations and top quark decays to leptons and jets, so that experimental cuts can be matched

Differential cross section

$$\frac{d\sigma}{d\cos\theta} = \mathcal{A}_{SM} + \mathcal{A}_{INT} + \mathcal{A}_{NPS} \quad f_L = 0$$

$$\mathcal{A}_{SM} = \frac{2g_s^4}{9} (2 - \beta^2 + \beta^2 \cos^2 \theta)$$

$$\mathcal{A}_{INT} = \frac{\beta g_s^2 g_w^2}{72\pi \hat{s}} \frac{f_R^2}{\hat{s}(\hat{t} - m_{Z'}^2)} \left[2(\hat{u} - m_t^2)^2 + 2\hat{s}m_t^2 + \frac{m_t^2}{m_{Z'}^2} ((\hat{t} - m_t^2)^2 + \hat{s}m_t^2) \right]$$

$$\mathcal{A}_{NPS} = \frac{\beta g_w^4}{128\pi \hat{s}} \frac{f_R^4}{(\hat{t} - m_{Z'}^2)^2} \left[4(\hat{u} - m_t^2)^2 + \frac{m_t^4}{m_{Z'}^4} (4\hat{s}m_{Z'}^2 + (\hat{t} - m_{Z'}^2)^2) \right]$$

$$\beta = \sqrt{1 - \frac{4m_t^2}{\hat{s}}}$$

★ INT contribution is negative because $\hat{t} < 0$

★ NPS contribution is positive

★ For heavy Z' , one needs a large f_R such that NPS contribution dominates over INT contribution to produce positive A_{FB} .

Determination of f_R

A_{FB} requires large couplings while $\sigma(t\bar{t})$ prefers small couplings.

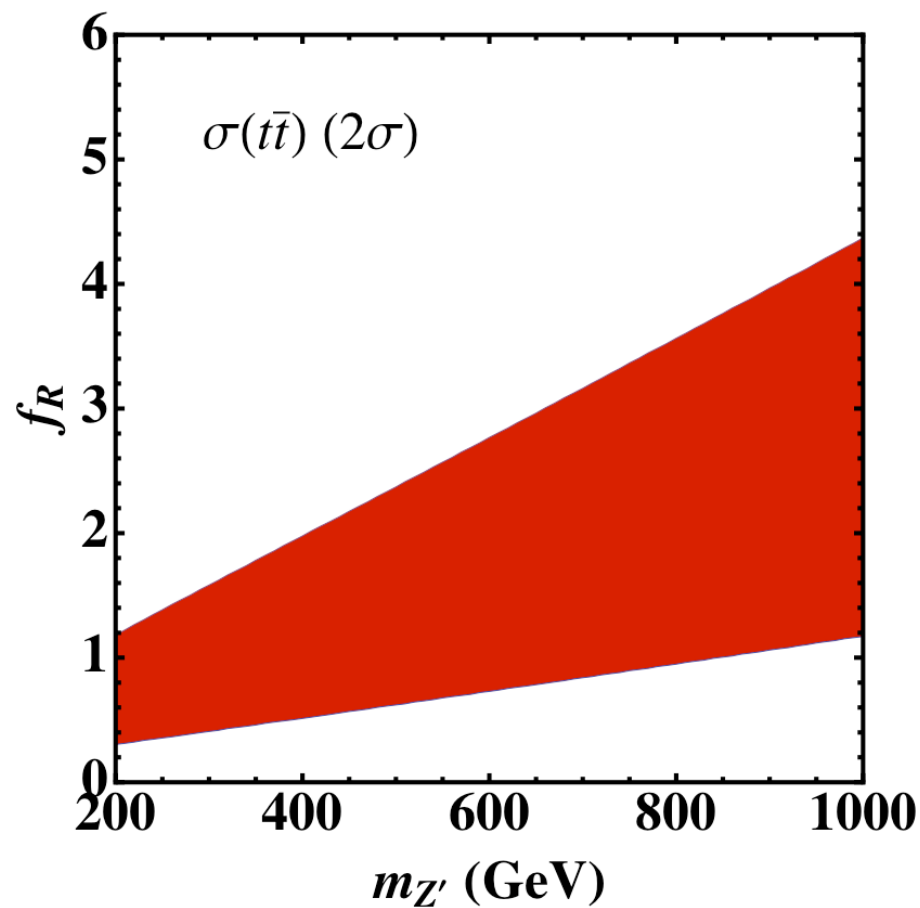
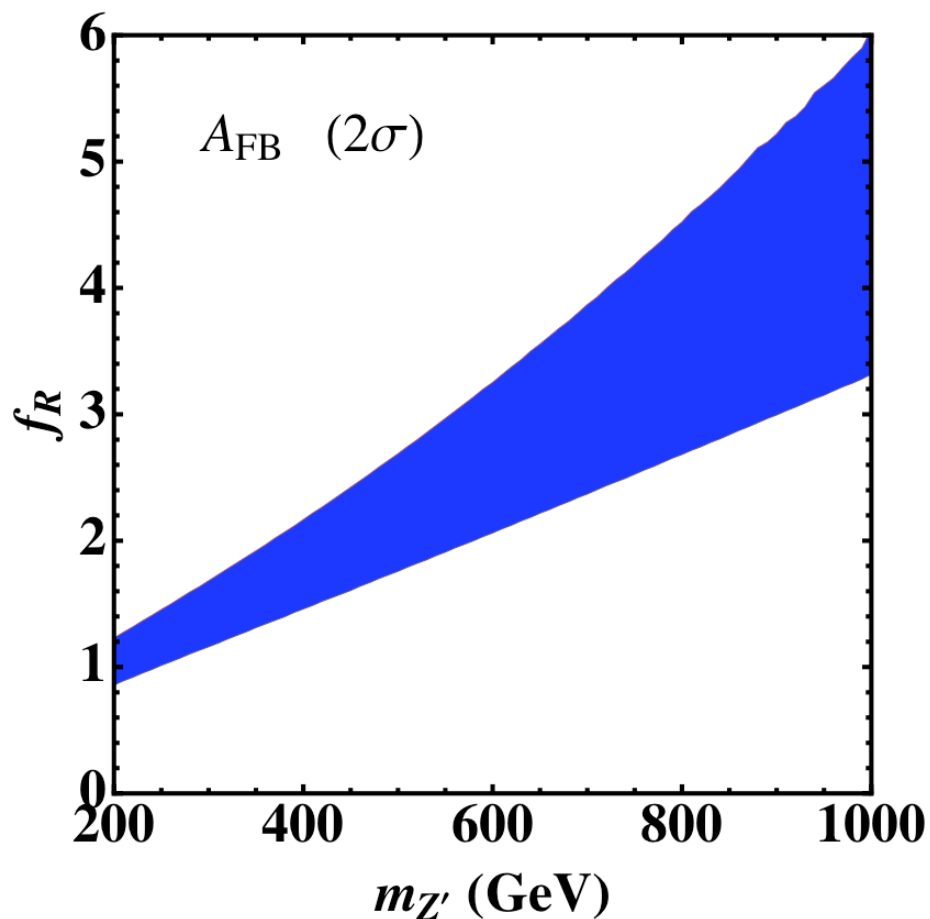

$$A_{FB} = 0.475 \pm 0.114 \quad \text{for} \quad m_{t\bar{t}} \geq 450 \text{ GeV}$$
$$\sigma_{t\bar{t}} = 7.50 \pm 0.48 \text{ pb} \quad \text{for} \quad m_t = 172.5 \text{ GeV} \quad (\text{CDF, } 4.6\text{fb}^{-1})$$

Determination of f_R

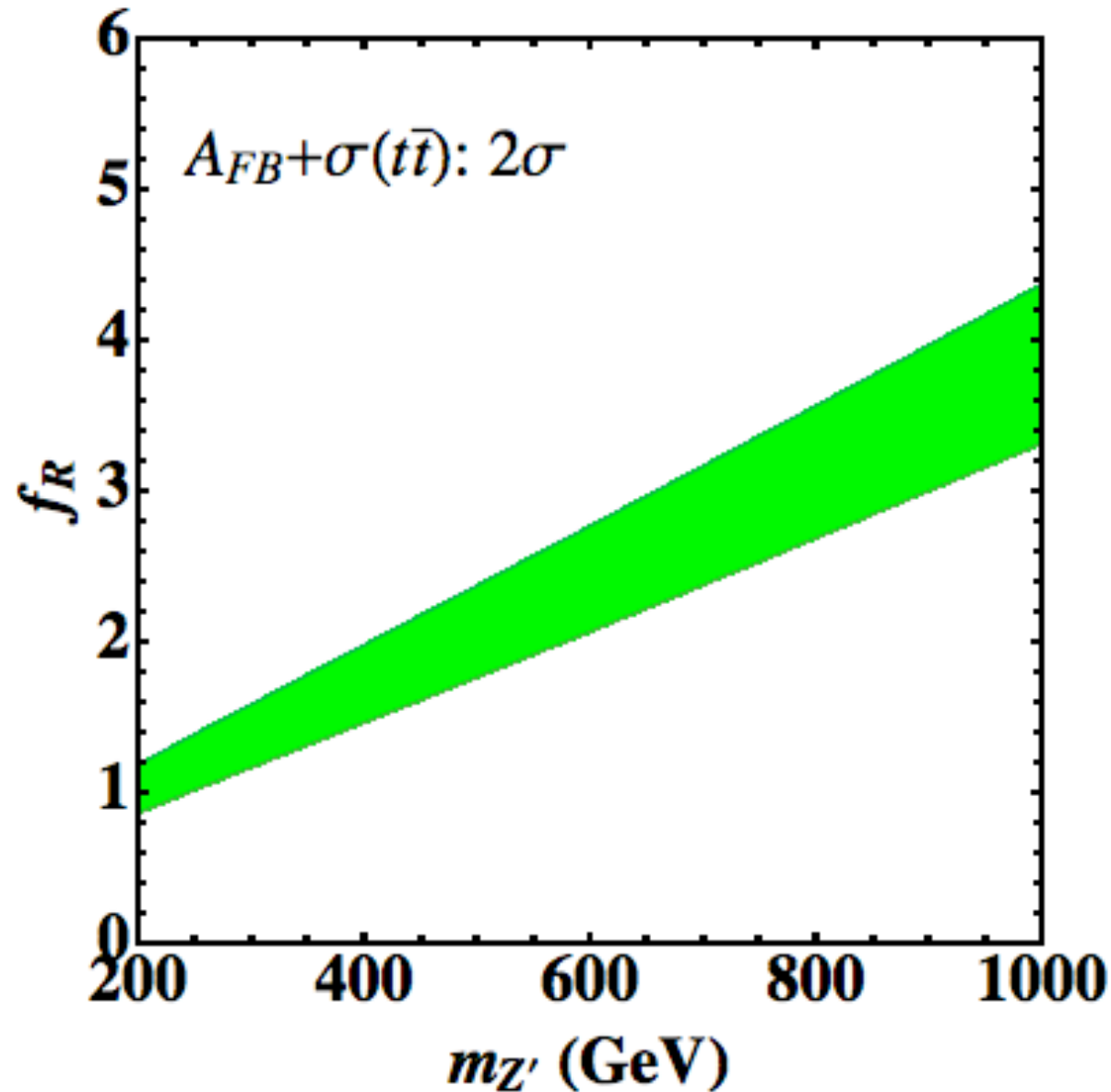

We take the overlap region as a good fit to both:

$$\sigma(tt) \quad A_{FB}$$

$m_{t\bar{t}}$ spectrum ($m_t = 175 \text{ GeV}$)

- Consistent with $m_{t\bar{t}}$ spectrum at 2σ level

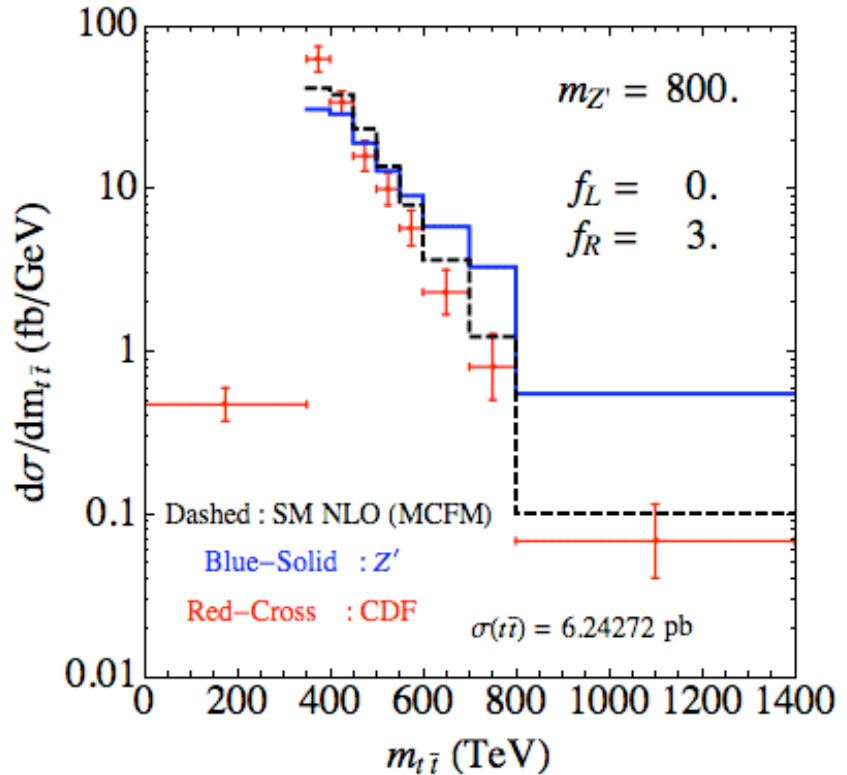
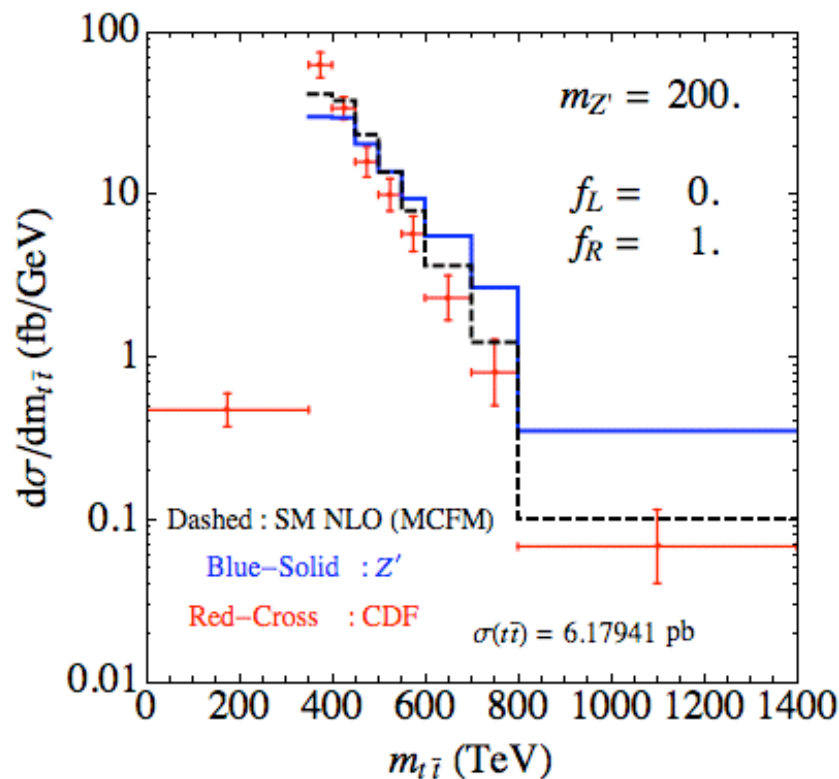

- $\sigma(t\bar{t})_{\text{NLO}} = 6.38 \text{ pb} \pm 0.50 \text{ pb}$ $\mu_R = \mu_F = m_t$
- $K_{\text{Fac}} \simeq 1$ for interference and NP squared terms

Xiao et al, Phys.Rev.D82:034026,2010.

Same-sign top pair production

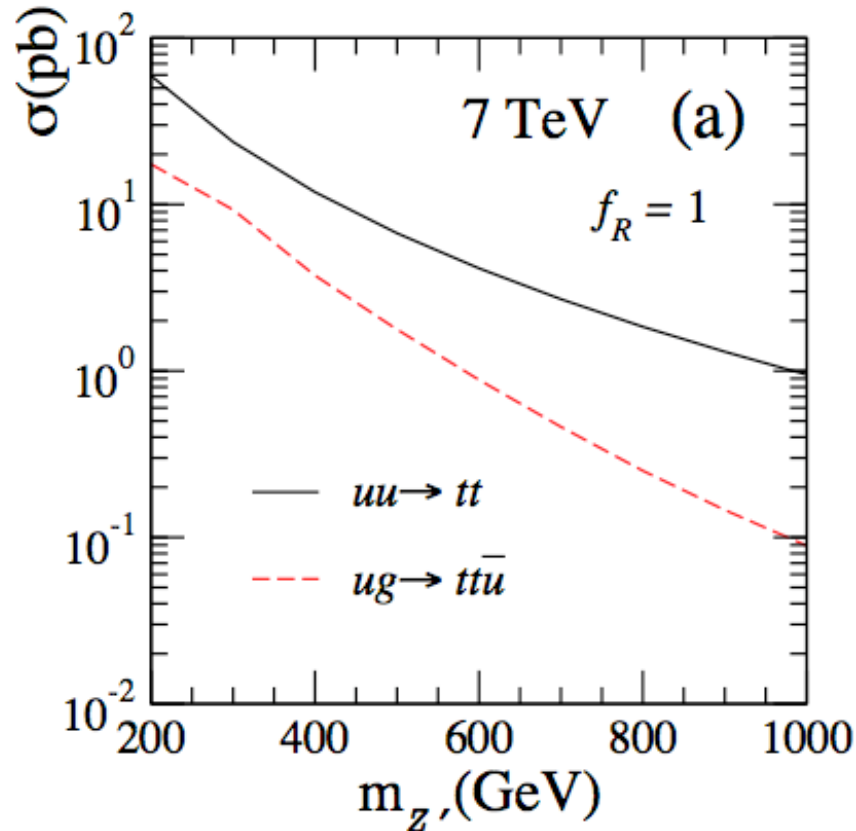

- Collider simulation

$$n_j = 2, \quad n_{\mu^+} = 2,$$

$$p_T^j \geq 50 \text{ GeV}, \quad |\eta_j| \leq 2.5,$$

$$p_T^\ell \geq 50 \text{ GeV}, \quad |\eta_\ell| \leq 2.0,$$

$$\Delta R_{jj, j\ell, \ell\ell} > 0.4,$$

$$\cancel{E}_T \geq 20 \text{ GeV}$$

two b -tagged jets

The same sign top quark pair cross section grows as f_R^4 .

SM backgrounds

$$\left. \begin{aligned} pp &\rightarrow t\bar{t} \rightarrow b\bar{b}W^+W^-, W^+ \rightarrow \ell^+\nu, W^- \rightarrow jj, \bar{b} \rightarrow \ell^+ \\ pp &\rightarrow W_1^+W_2^+jj, W^+ \rightarrow \ell^+\nu \\ pp &\rightarrow W^+W^+W^-, W^+ \rightarrow \ell^+\nu, W^- \rightarrow jj \\ pp &\rightarrow ZW^+W^-, Z \rightarrow \ell^+\ell^-, W^+ \rightarrow \ell^+\nu, W^- \rightarrow jj \end{aligned} \right\} \text{Dominant backgrounds}$$

- ★ Matrix element calculation of signal and backgrounds retains all spin correlations .
- ★ About 1 background event survives after all kinematic cuts.
- ★ Based on Poisson statistics we demand 8 signal events for a 5σ discovery.