

The proton size and Zemach radius from muonic hydrogen

Paul Indelicato



CREMA: Muonic Hydrogen Collaboration

F.D Amaro, A. Antognini, **F. Biraben**, J.M.R. Cardoso, D.S. Covita, A. Dax, S. Dhawan, L.M.P. Fernandes, A. Giesen, T. Graf, T.W. Hänsch, **P. Indelicato**, **L. Julien**, C.-Y. Kao, P.E. Knowles, F. Kottmann, J.A.M. Lopes, **E. Le Bigot**, Y.-W. Liu, L. Ludhova, C.M.B. Monteiro, F. Mulhauser, T. Nebel, **F. Nez**, R. Pohl, P. Rabinowitz, J.M.F. dos Santos, L.A. Schaller, K. Schuhmann, C. Schwob, D. Taqqu, J.F.C.A. Veloso



UNIVERSIDADE DE COIMBRA



INSTITUT FÜR STRAHLWERKZEUGE



UNIVERSITÉ DE FRIBOURG / UNIVERSITÄT FREIBURG



universidade de aveiro



DEPARTMENT OF PHYSICS
National Tsing Hua University

2 quarks **up** ($2/3 e$) + 1 quark **down** ($-1/3 e$) + strong interaction (**gluons**)

Vertex EM interaction: Dirac and Pauli Form factors
(S, P : spin and 4-momentum of nucleon, f : quark flavor)

$$\langle P', S' | V_{(f)}^\mu | P, S \rangle = \bar{U}(P', S') \left[\gamma^\mu F_1^{(f)}(Q^2) + i\sigma^{\mu\nu} \frac{q_\nu}{2M_N} F_2^{(f)}(Q^2) \right] U(P, S),$$

$$V_{(f)}^\mu = \bar{\psi}_{(f)} \gamma^\mu \psi_{(f)},$$

Physical charge density are derived from the Sachs Form factors

$$G_E(Q^2) = F_1(Q^2) - \frac{Q^2}{(2M_N)^2} F_2(Q^2),$$

$$G_M(Q^2) = F_1(Q^2) + F_2(Q^2).$$

Measure the moments of the charge distribution:

$$G_N(q^2) = \int d\mathbf{r} e^{-i\mathbf{q} \cdot \mathbf{r}} \frac{\rho_N(\mathbf{r})}{4\pi},$$

$$\langle r^n \rangle = \int_0^\infty r^{2+n} \rho(r) dr,$$

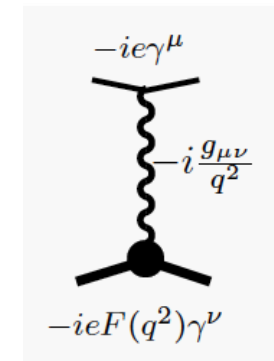
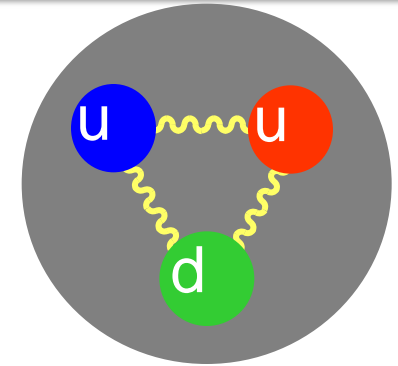

Electron-proton scattering

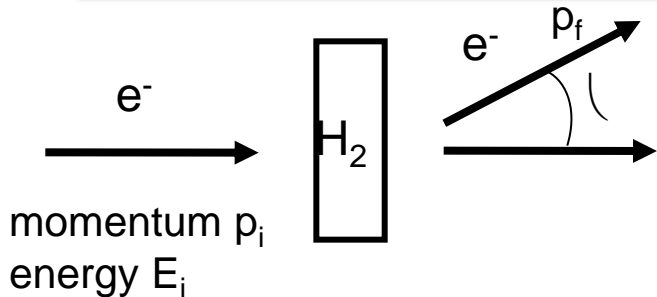

$$q = 2p_f \sin\left(\frac{\theta}{2}\right)$$

$$G_N(q^2) = \frac{1}{\left(1 + \frac{R^2 q^2}{12}\right)^2} \approx 1 - \frac{R^2}{6} q^2 + \frac{R^4}{48} q^4 + \dots$$

$$\frac{d\sigma(E_i, \theta)}{d\omega} = \frac{d\sigma_{\text{Rut.}}(E_i, \theta)}{d\omega} G_E(q^2)$$

$$G_N(q^2) = e^{-\frac{1}{6} R^2 q^2} \approx 1 - \frac{R^2}{6} q^2 + \frac{R^4}{72} q^4 + \dots$$

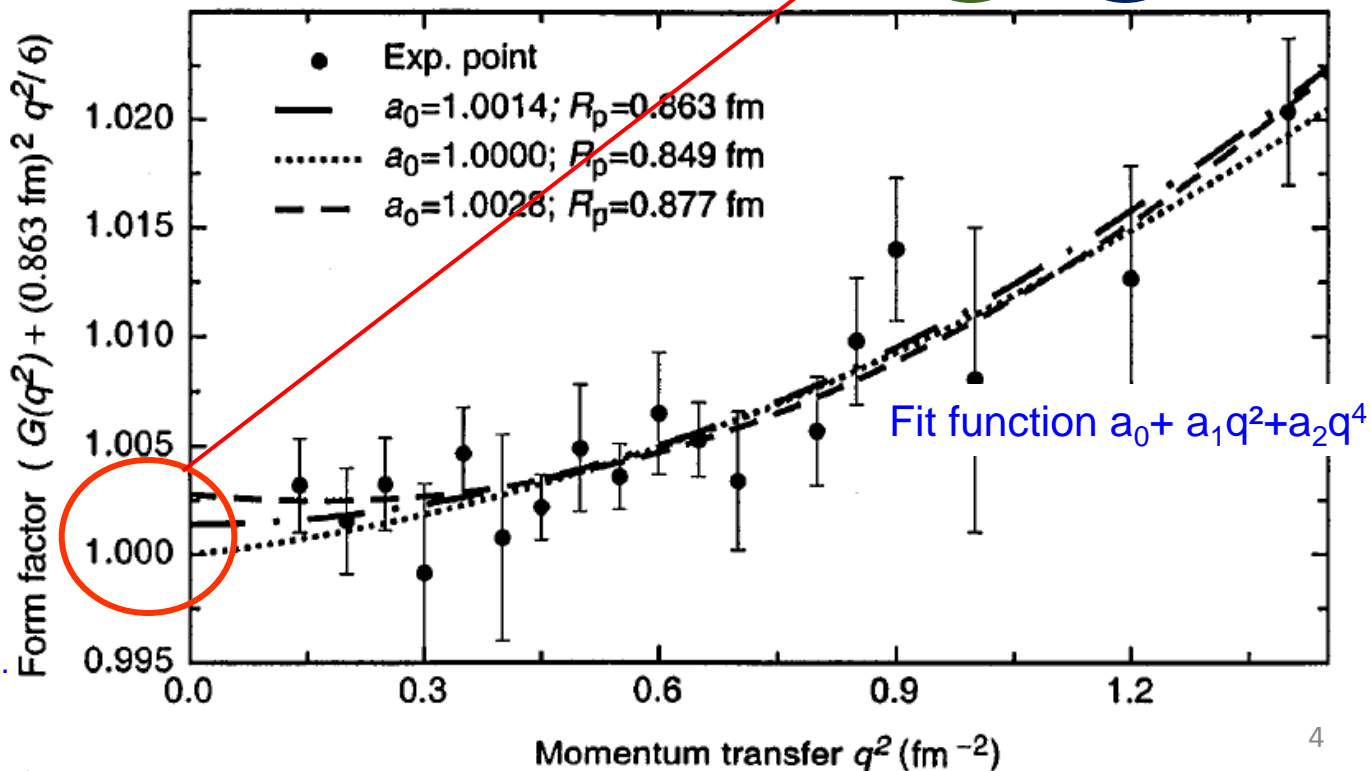

see S. Karshenboim in Can. J. Phys. 77, 241-266 (1999) and refs therein
 DPE 2011

Muonic hydrogen spectroscopy

Exotic atom

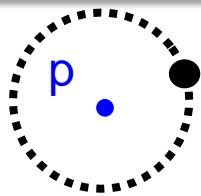

$$\frac{m_\mu}{m_e} = 207$$

radius : $\sim a_0/200$

$$\mathcal{E}_{NS} = \frac{2}{3} \left(\frac{m_\mu}{m_e} \right)^3 \frac{(Z\alpha)^2}{n^3} m_e c^2 \left(\frac{Z\alpha R_N}{\lambda_C} \right)^2$$

Lamb shift = self-energy + vacuum polarization + proton radius

2S-2P	self-energy	vacuum pol.	r_p	total
e-p	1084.1 MHz	-26.9 MHz	0.146 MHz	1057.8 MHz
μ -p	0.17 THz	-50.94 THz	0.96 THz	-49,81 THz

electronic hydrogen : e-p

muonic hydrogen : μ -p

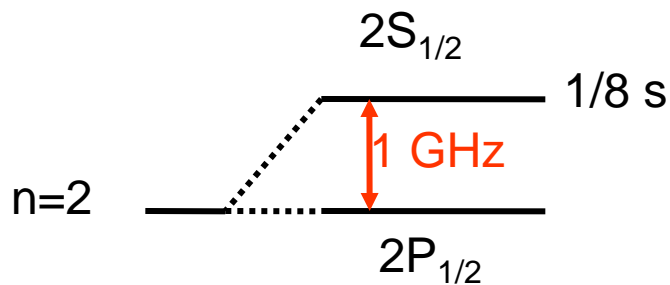

$$(f_{\mu p}/f_{ep}) \approx 1/(200)^3 \approx 10^{-7}$$

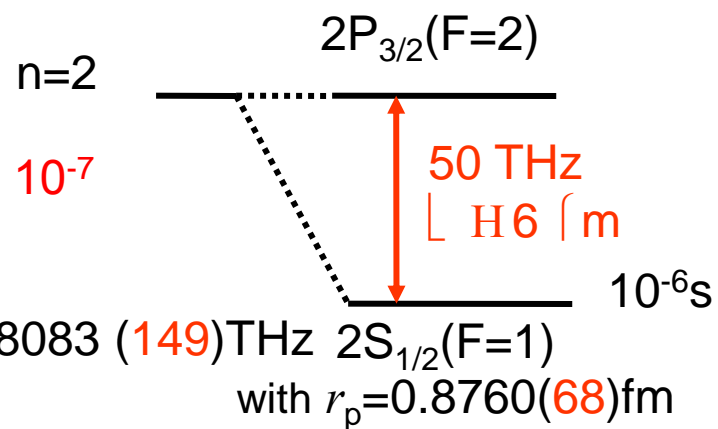

$$\otimes E_{2S-2P} = 50.7724(12) - 1.2637 r_p^2 - 0.0084 r_p^3 = 49.8083 (149) \text{ THz}$$

with $r_p = 0.8760(68) \text{ fm}$

muonic hydrogen 2S Lamb shift determination of the “proton radius”

Exotic atom

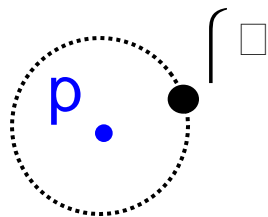

Experiment

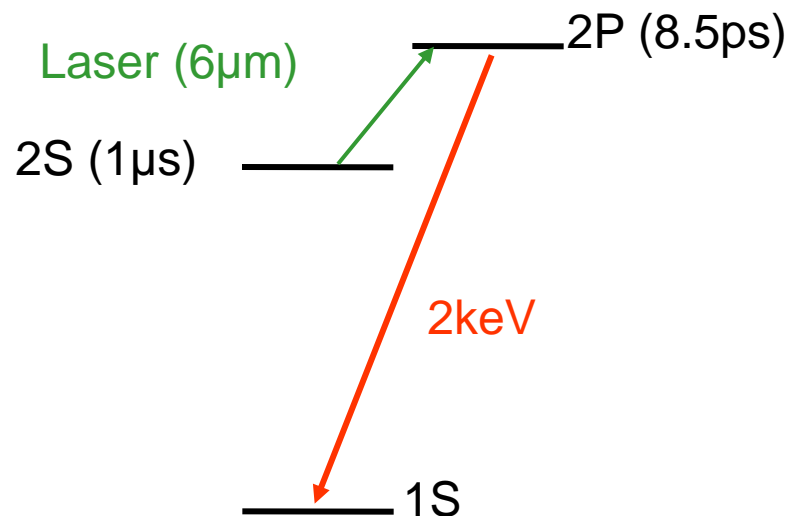

Challenges

- production of muonic hydrogen in 2S
- powerful triggerable 6 μ m laser
- small signal analysis

Aim : better determination of proton radius r_p

“prompt” ($t \sim 0$)



H_2

“delayed” ($t \sim 1\mu s$)

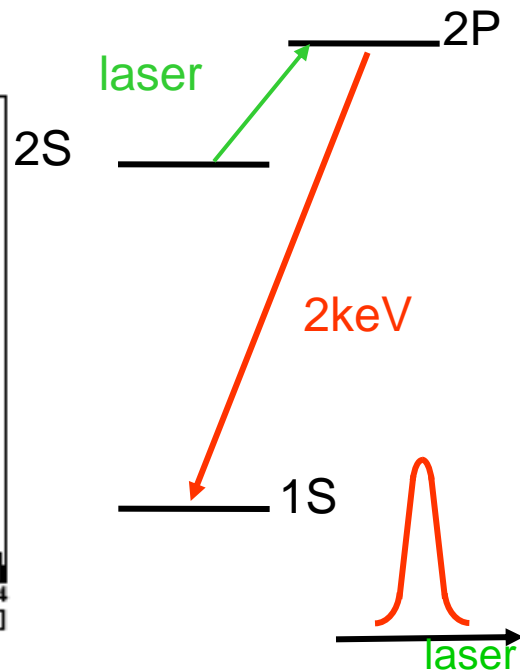
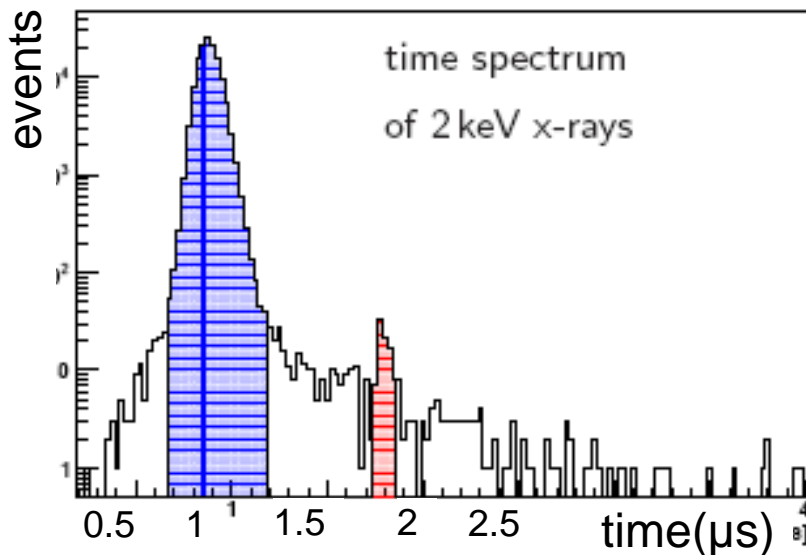
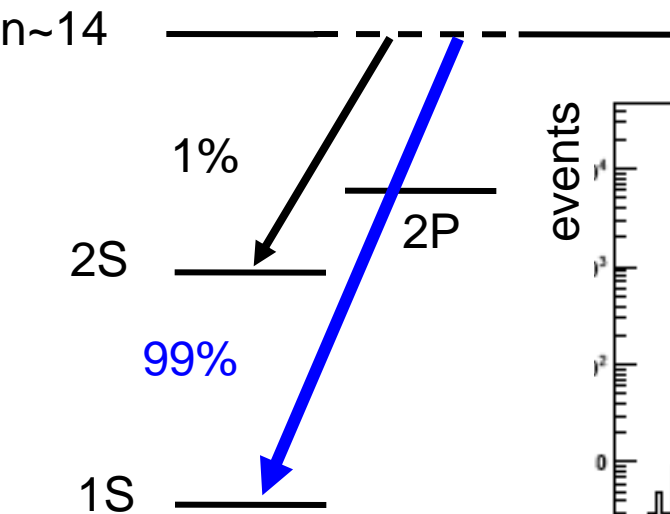

μ^- stop in H_2 gas

Ⓜ μp^* atoms formed ($n \sim 14$)

99%: cascade to 1S emitting prompt $K\alpha, K\beta, \dots$

1%: long lived 2S state ($\tau \sim 1\mu s$ at 1mbar)

Fire laser ($\lambda \sim 6\mu m, E \sim 0.2eV$)

Ⓜ induce $\mu p(2S-2P)$

Ⓜ observe delayed $K\alpha$ x-rays

Ⓜ normalize $\frac{\text{delayed } K\alpha}{\text{prompt } K\alpha}$ x-rays

muonic hydrogen source

PAUL SCHERRER INSTITUT



p (500MeV, 2mA) \rightarrow carbon target $\rightarrow \pi^- \rightarrow \mu^- + \pi^-$ (300 μ /s)

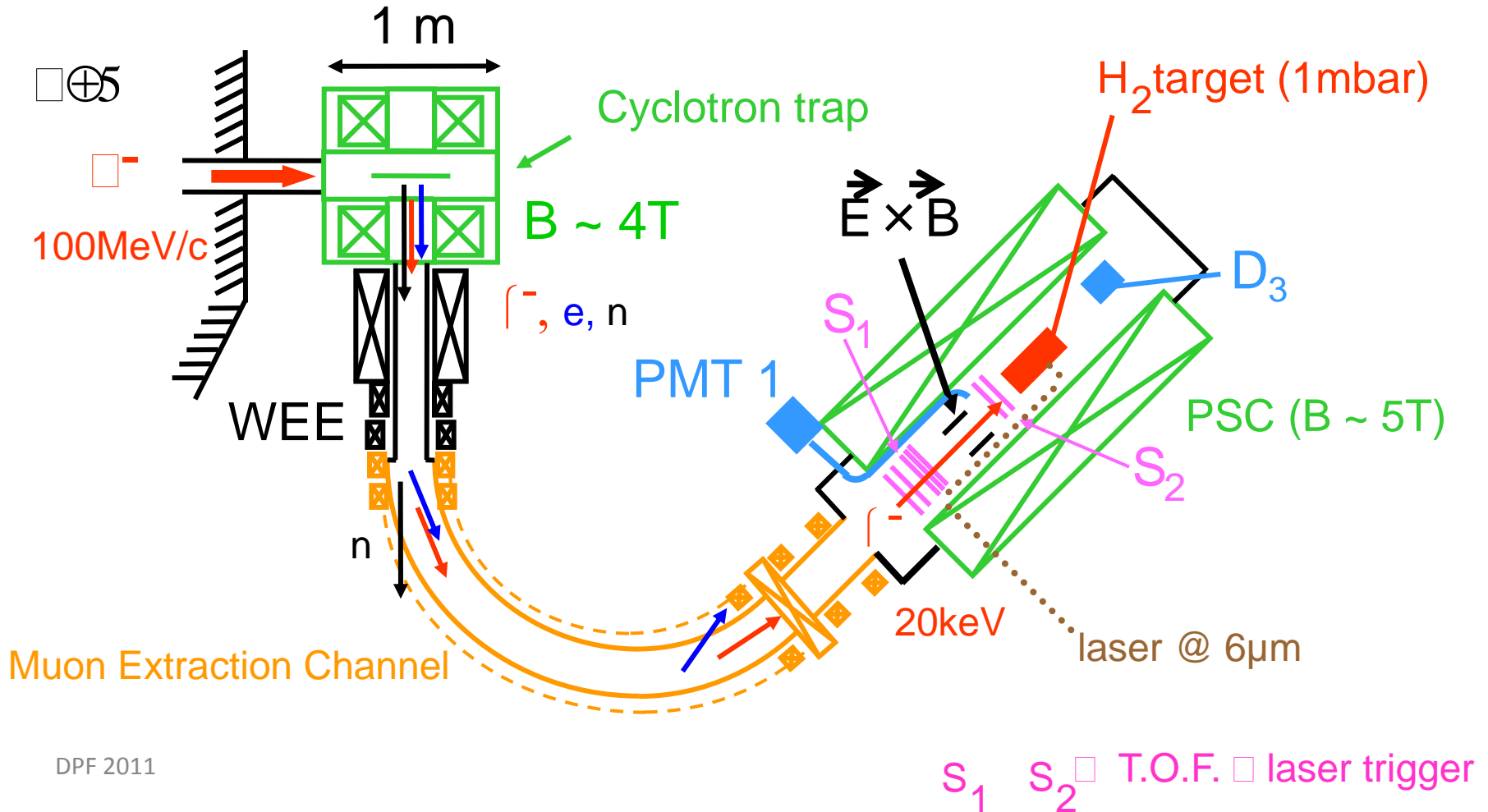

laser hut
below
concrete blocks

counting room

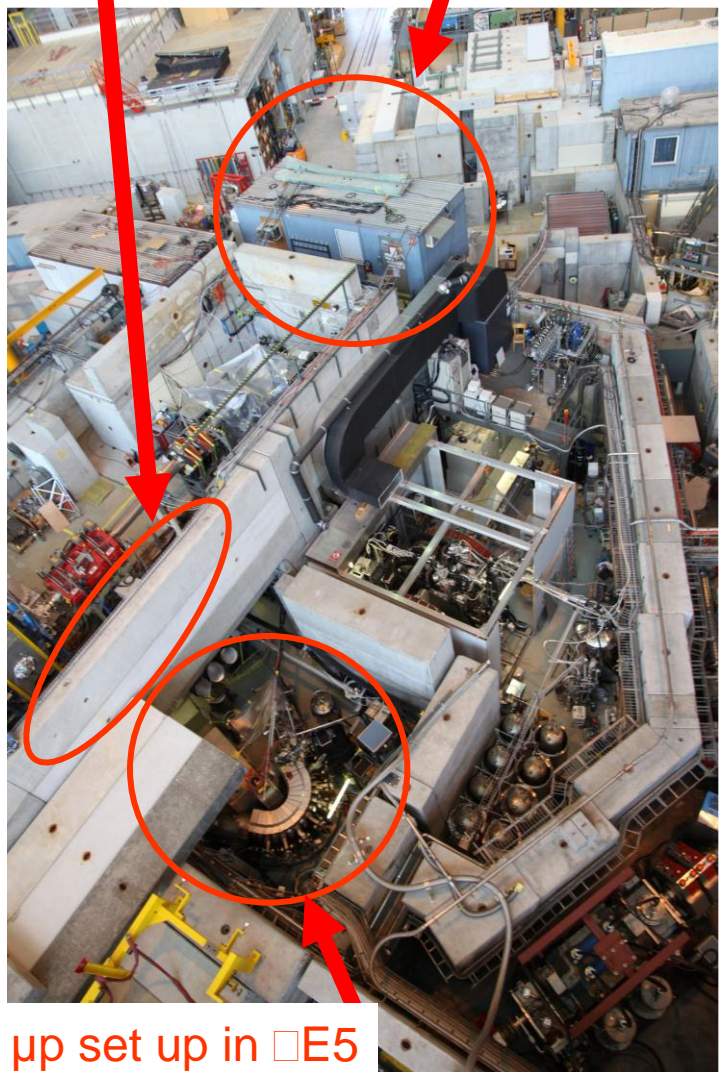

$\square \rightarrow \{ - + \}$

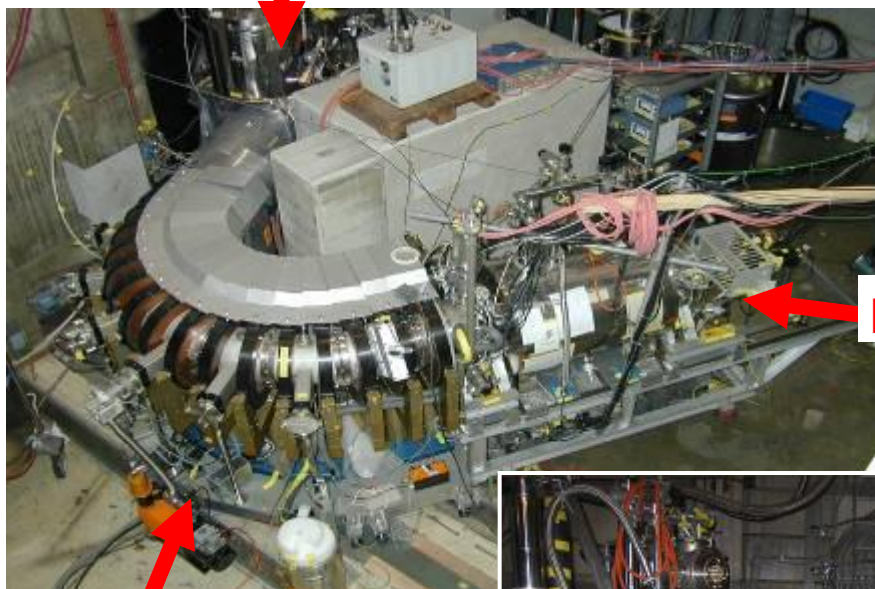

PSC solenoid,

Muon extraction
channel



H2 target, laser cavity,
detectors

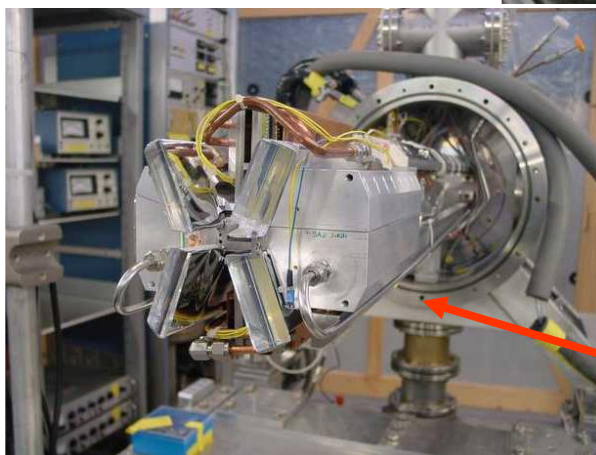

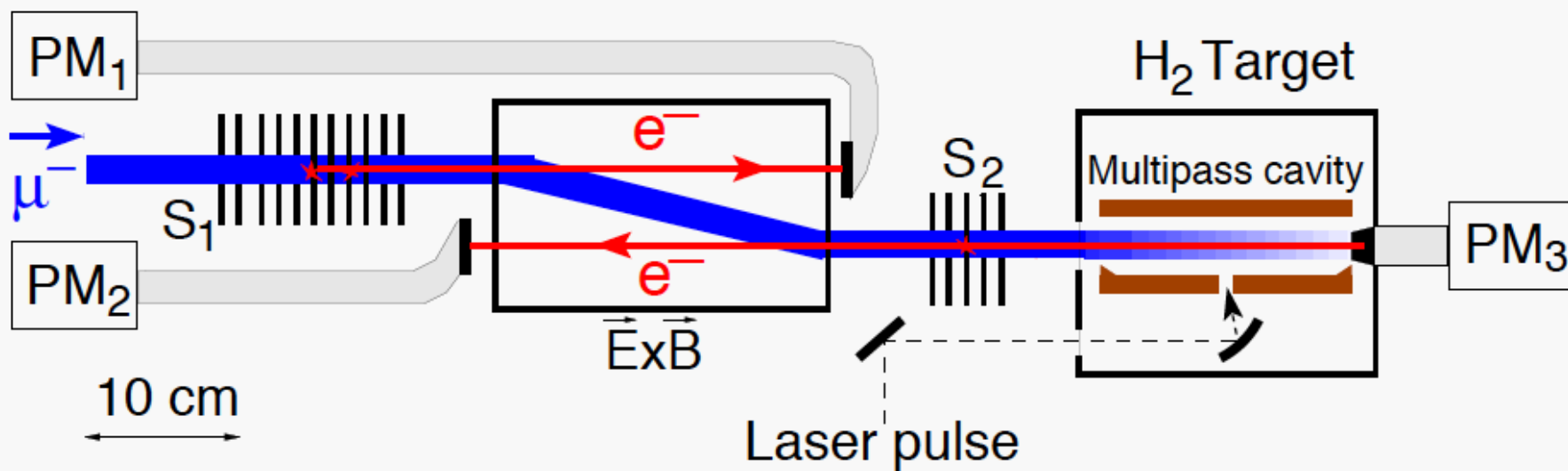

Laser chain

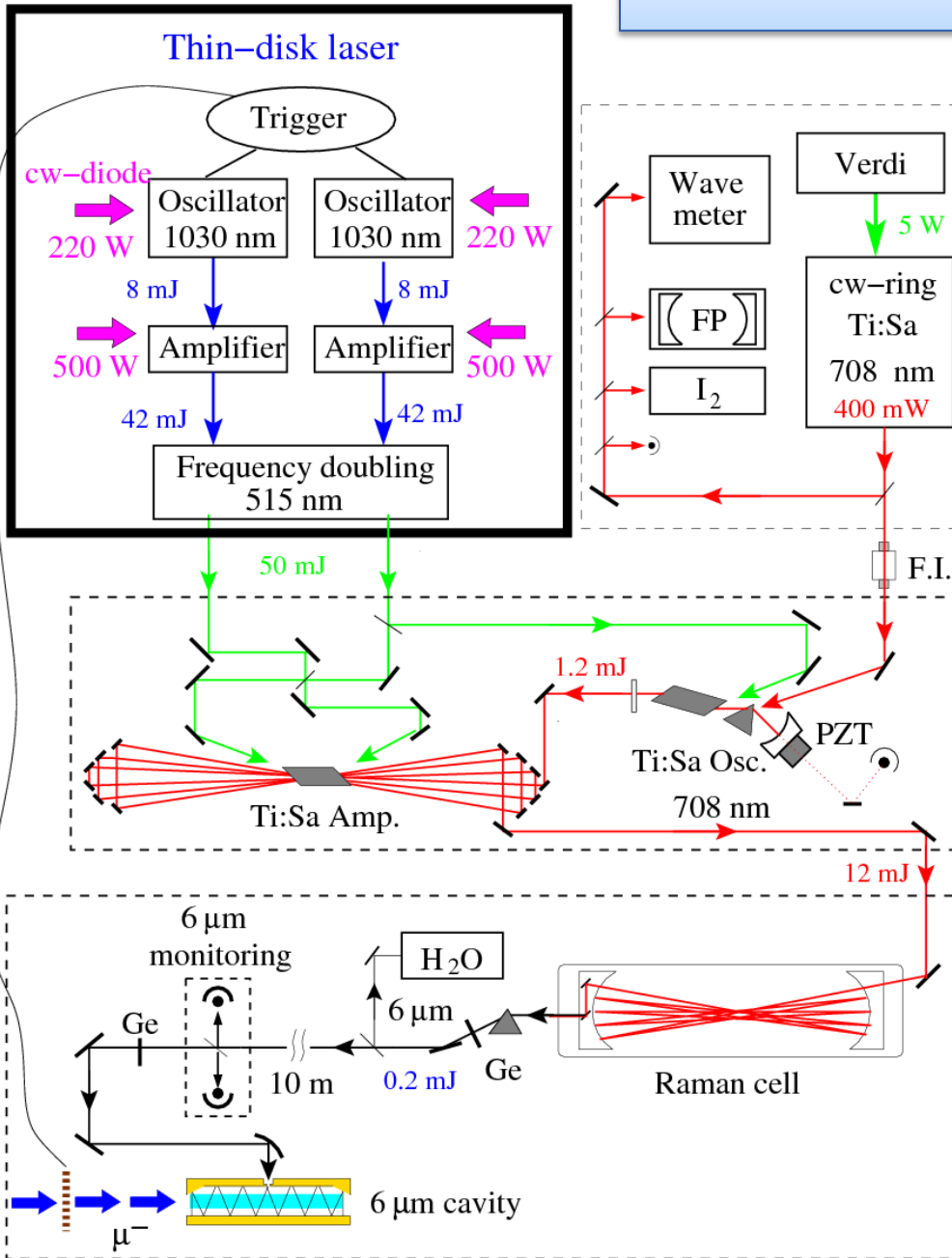

- Each single muon triggers the laser system (random trigger)
- 2S lifetime $\sim 1\mu\text{s}$ □ short laser delay (disk laser)
- 6 μm tunable laser pulse (0.2mJ)

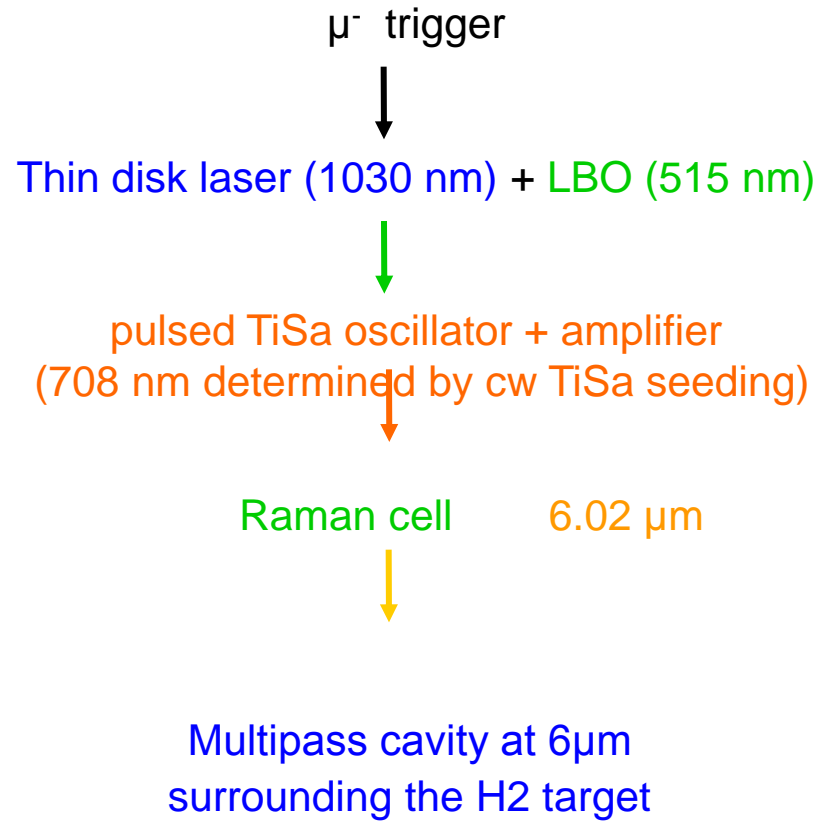

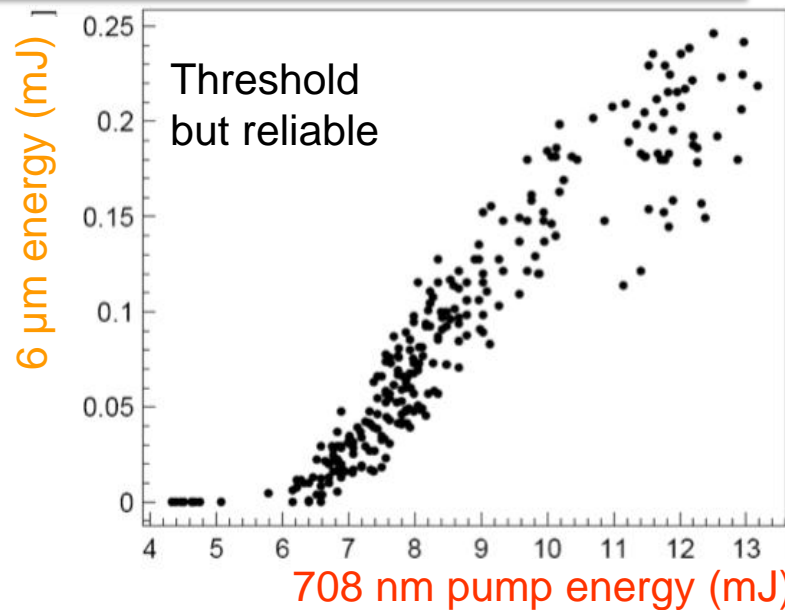
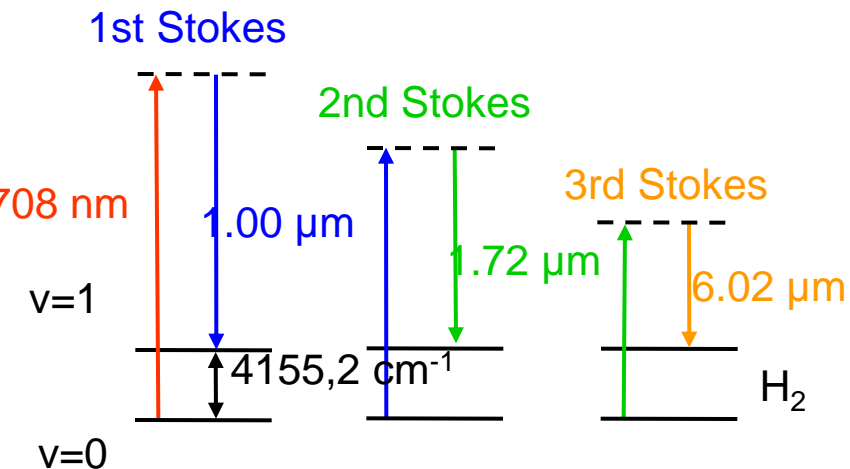
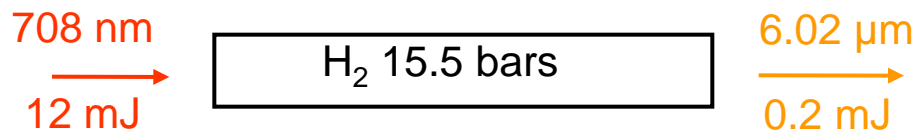

6 μm frequency calibration : H₂O lines

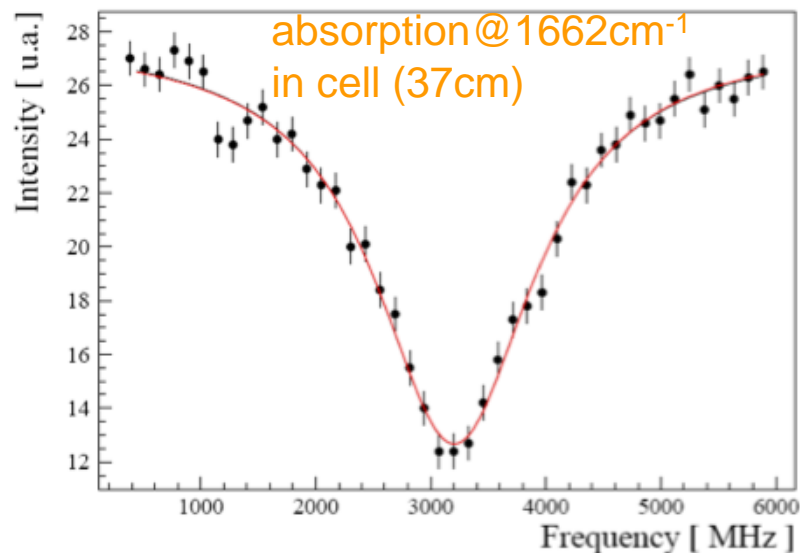
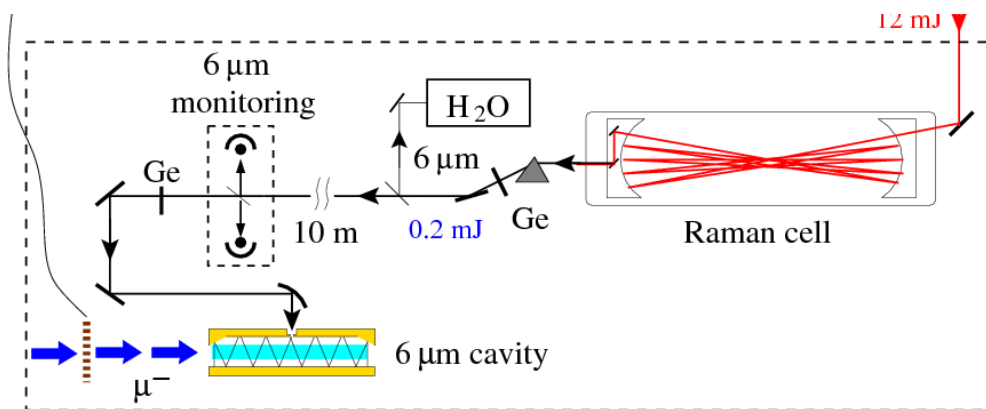

→ illuminate at 6 μm all the muon stopping volume (5 × 15 × 190 mm³)

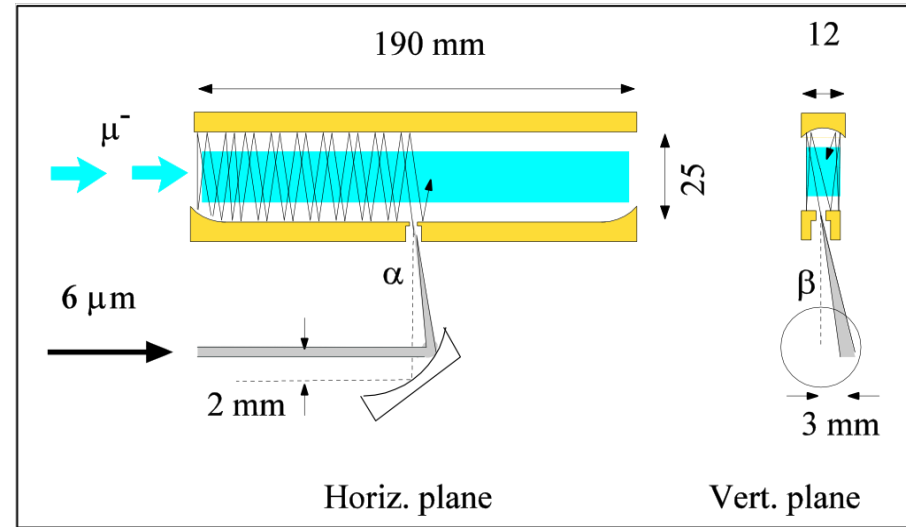
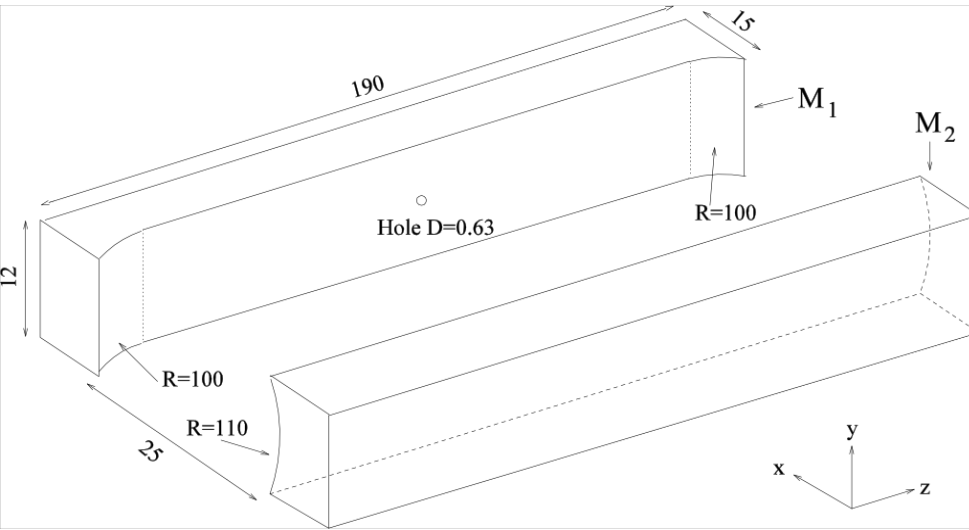

- coupling through a 0.63mm diameter hole
- R=99.90% at 6 μm
- 1000 reflections
- 0.15mJ injected → 2S-2P saturated

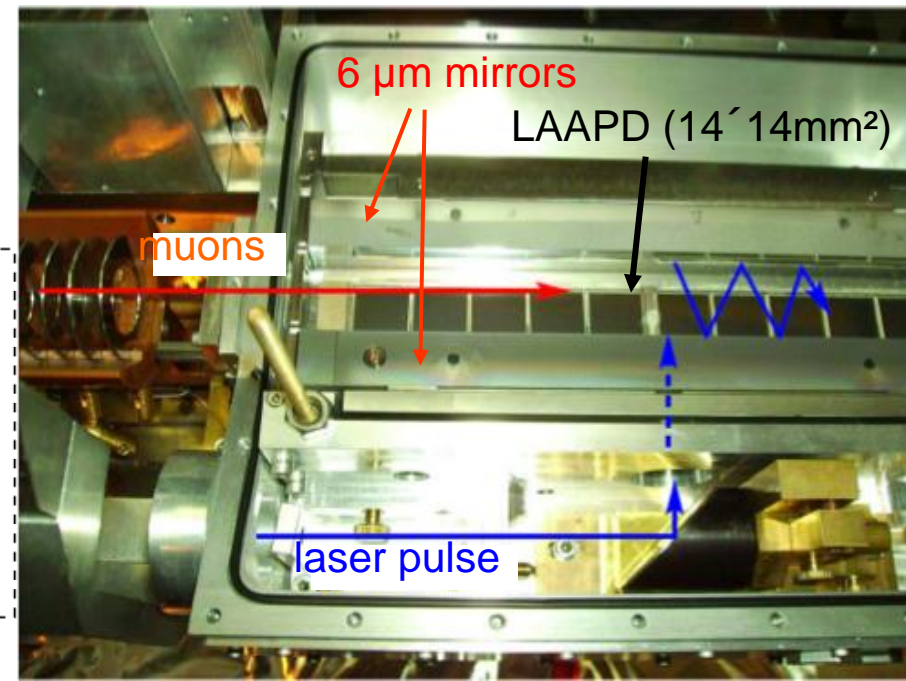
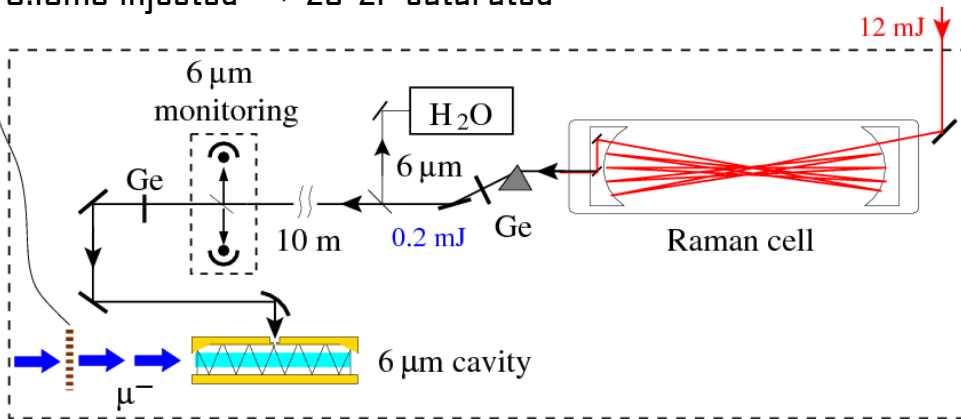

X-rays analysis → event gate sorting → noise rejection

Example : FP 900 - 11 hrs meas.

1.56 million detector events

expected 2-3 laser induced events/hour !

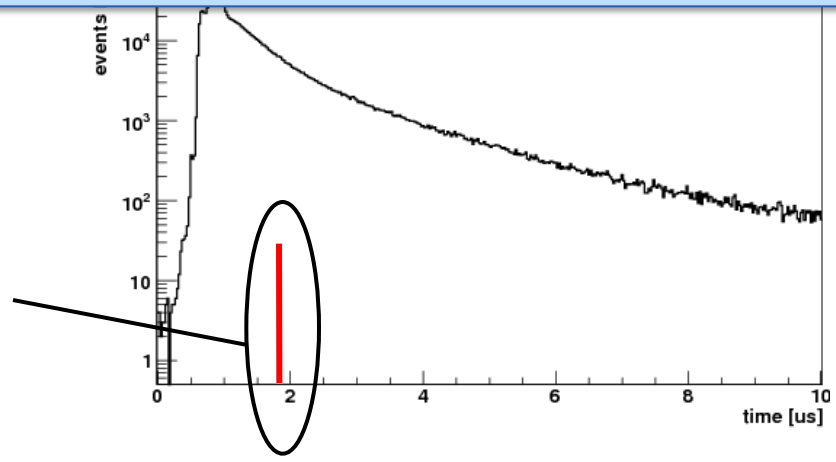

time signature in LAAPD

- photon < 10keV □ 1 shot in the LAAPD
- e⁻ in B = 5T □ many counts in detectors

energy signature in LAAPD

- E > 8keV TM electron
- 1keV < E < 8keV TM X ray
- E < 1keV TM neutron

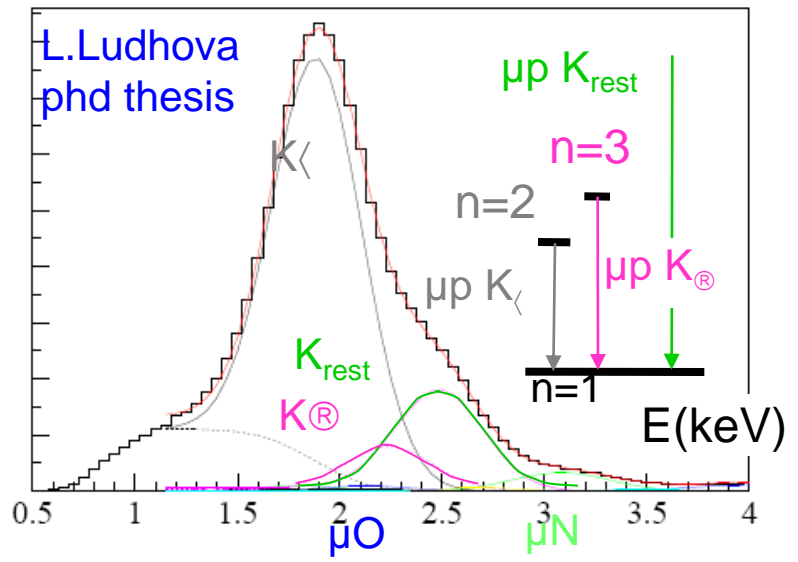
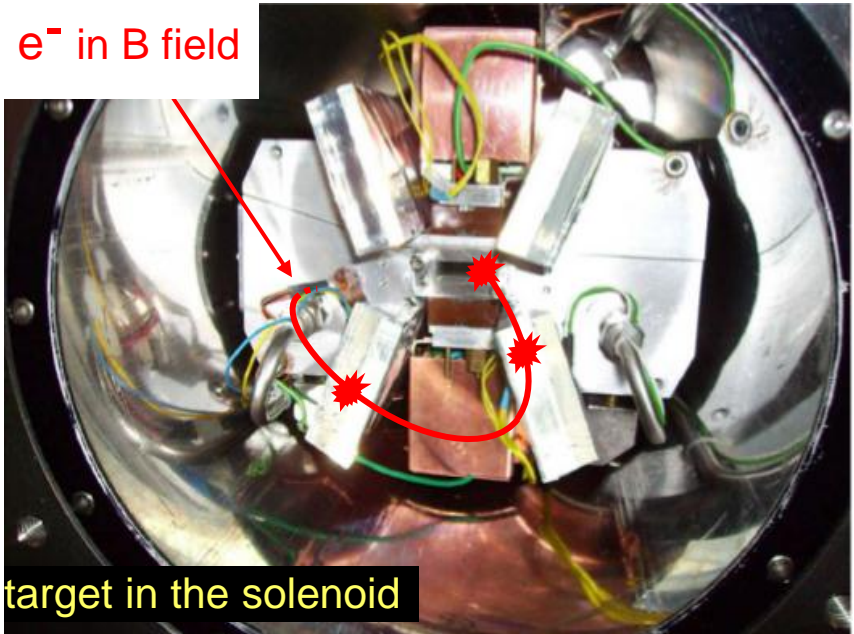

Example : FP 900 - 11 hrs meas.

- 400 $\mu\text{/s}$
- 240 laser shot/s
- 860 000 laser shot/hour
- 1.56 million detector clicks
- 19600 clicks in the laser region
- expected 2-3 laser induced events/hour !

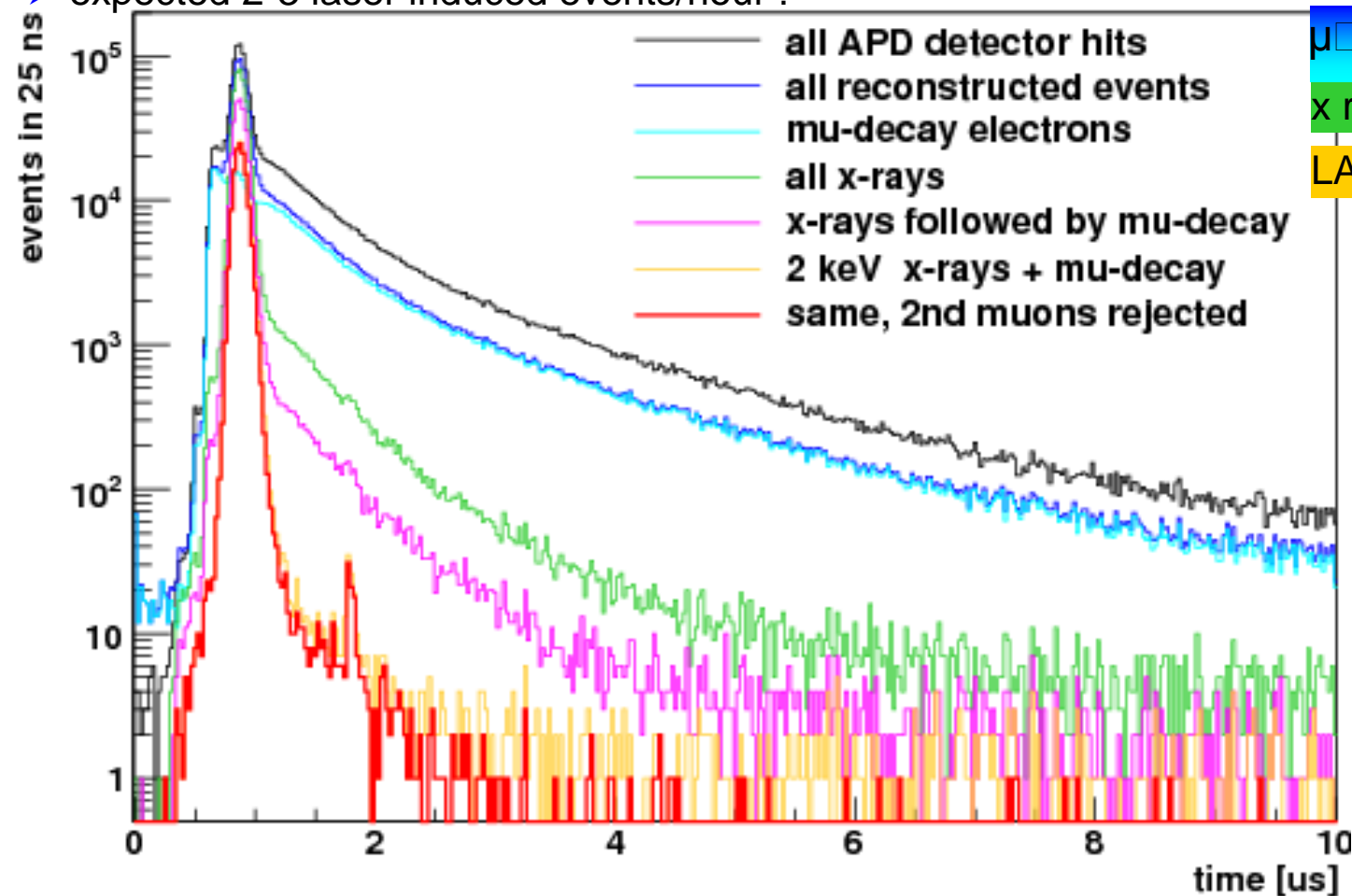

$\mu^+ e^- \rightarrow \mu^+ e^-$

x rays multiplicity 1

LAAPD energy resolution

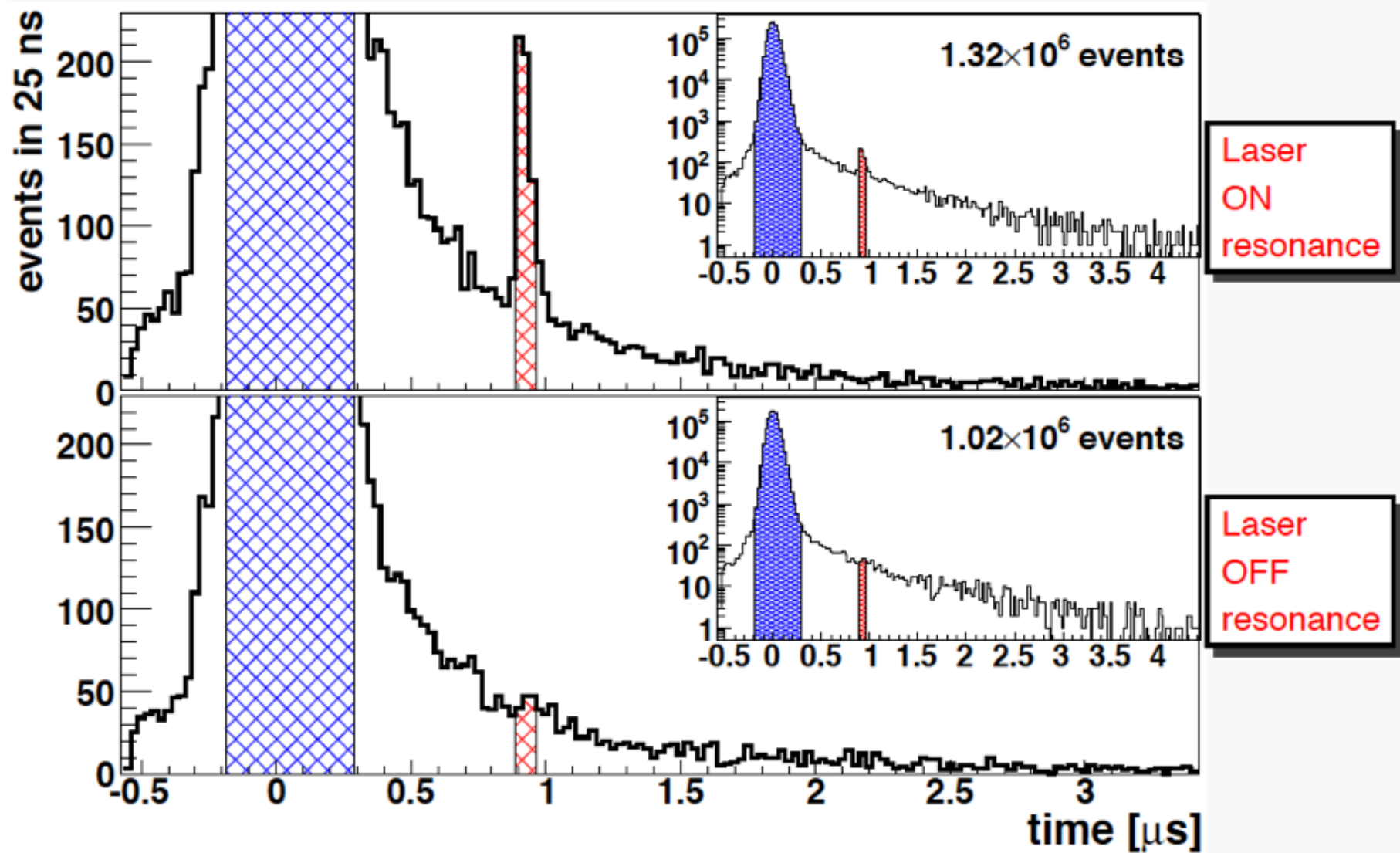

2002 : Run with all the parts at the same time (search for resonance 10 hrs).

2003 2S-2P resonance curve

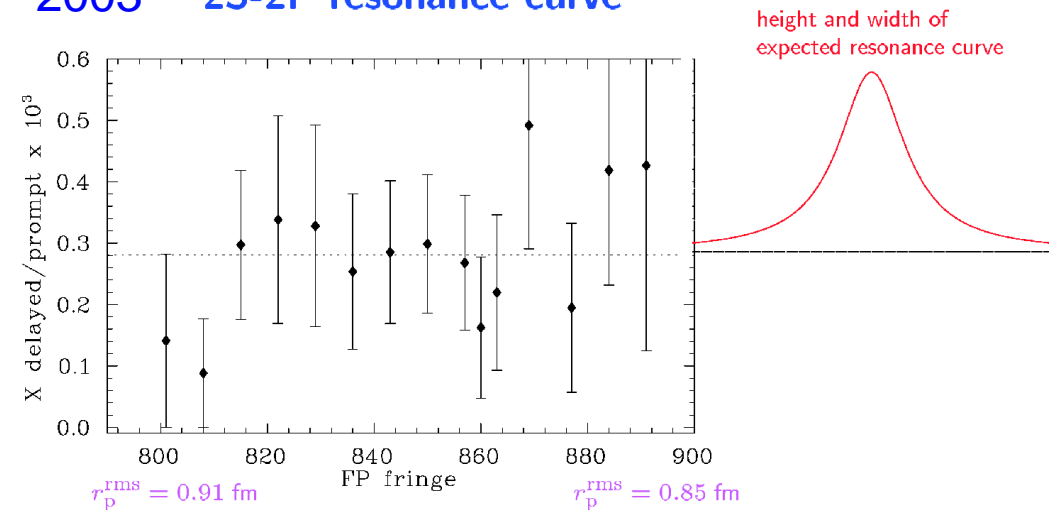

2 "new" XeCl lasers

delayed to prompt

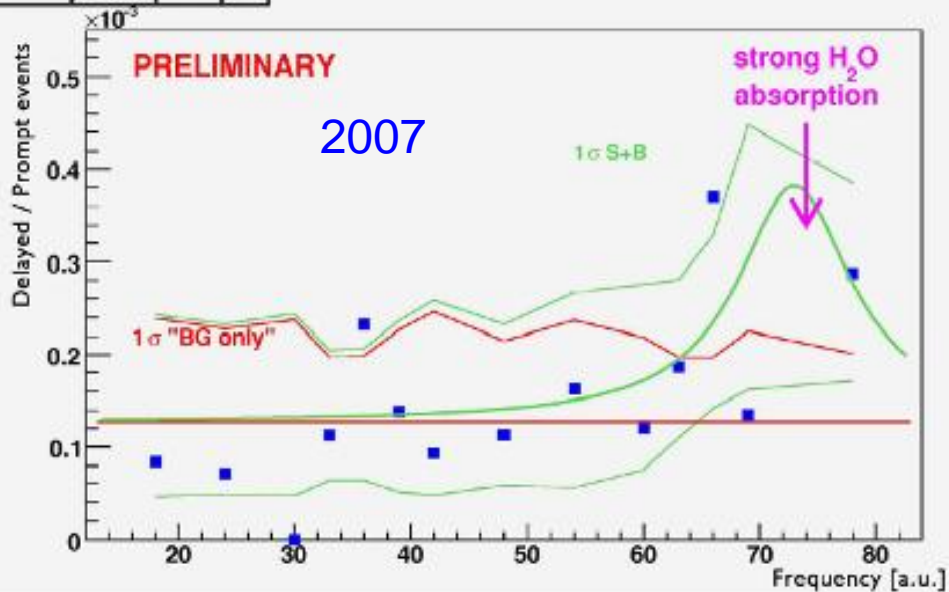

new disk laser

muonic hydrogen : $^2S_{1/2}(F=1) - ^2P_{3/2}(F=2)$

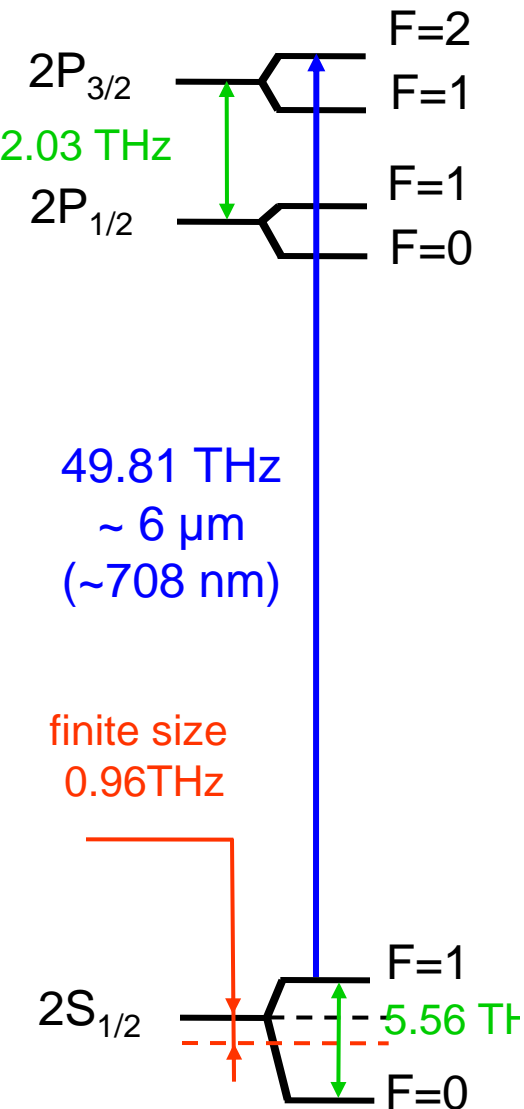

- 550 events measured
- 155 backgrounds
- 31 FP fringes
- 250 hours

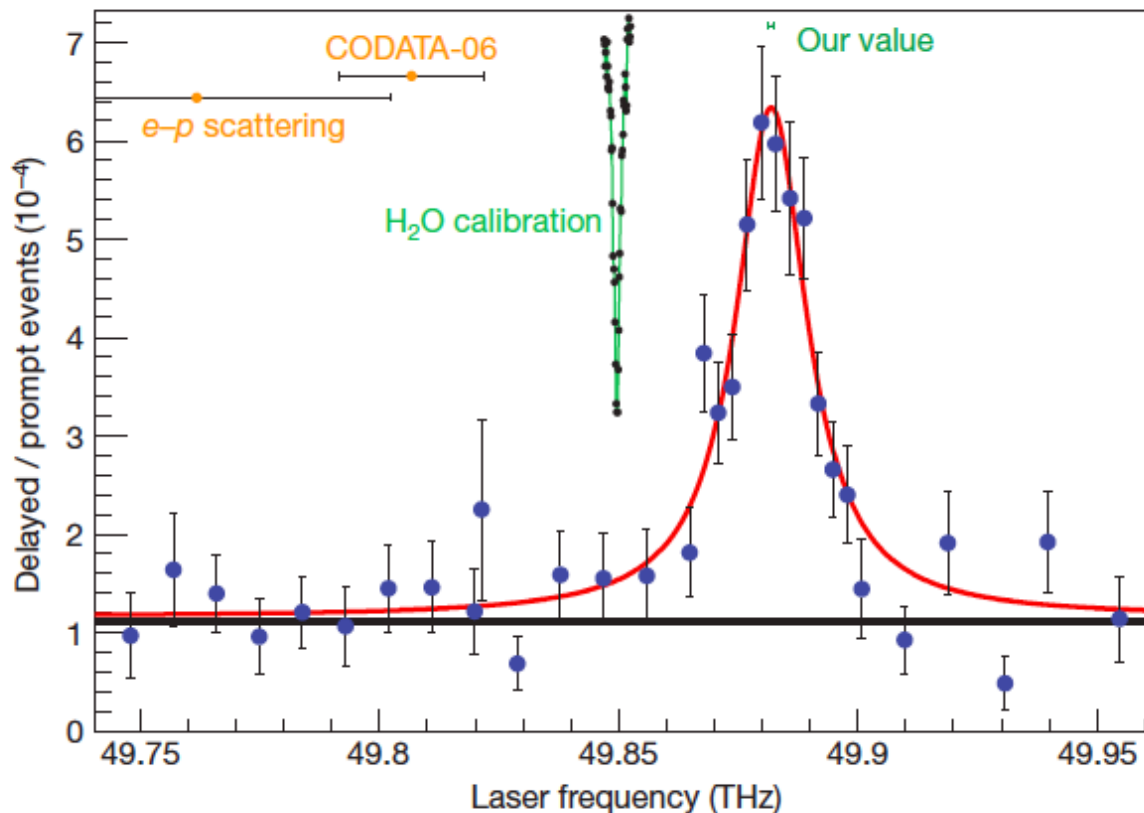

R. Pohl, A. Antognini, F. Nez, et al., Nature 466, 213 (2010).

nature

OIL SPILLS

There's more
to come

PLAGIARISM

It's worse than
you think

CHIMPANZEES

The battle for
survival

SHRINKING THE PROTON

New value from exotic atom
trims radius by four per cent

NATUREJOBS
Researchers for hire



muonic hydrogen : $^2S_{1/2}(F=0) - ^2P_{3/2}(F=1)$

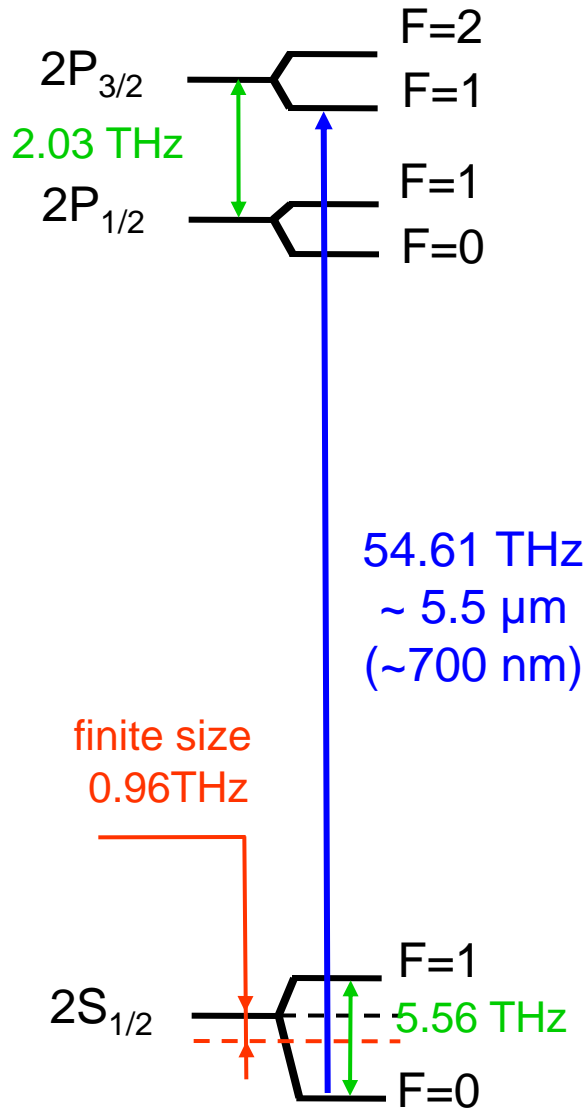

- measured position fits with our proton radius (preliminary)
- laser worked even better at $5.5 \mu\text{m}$

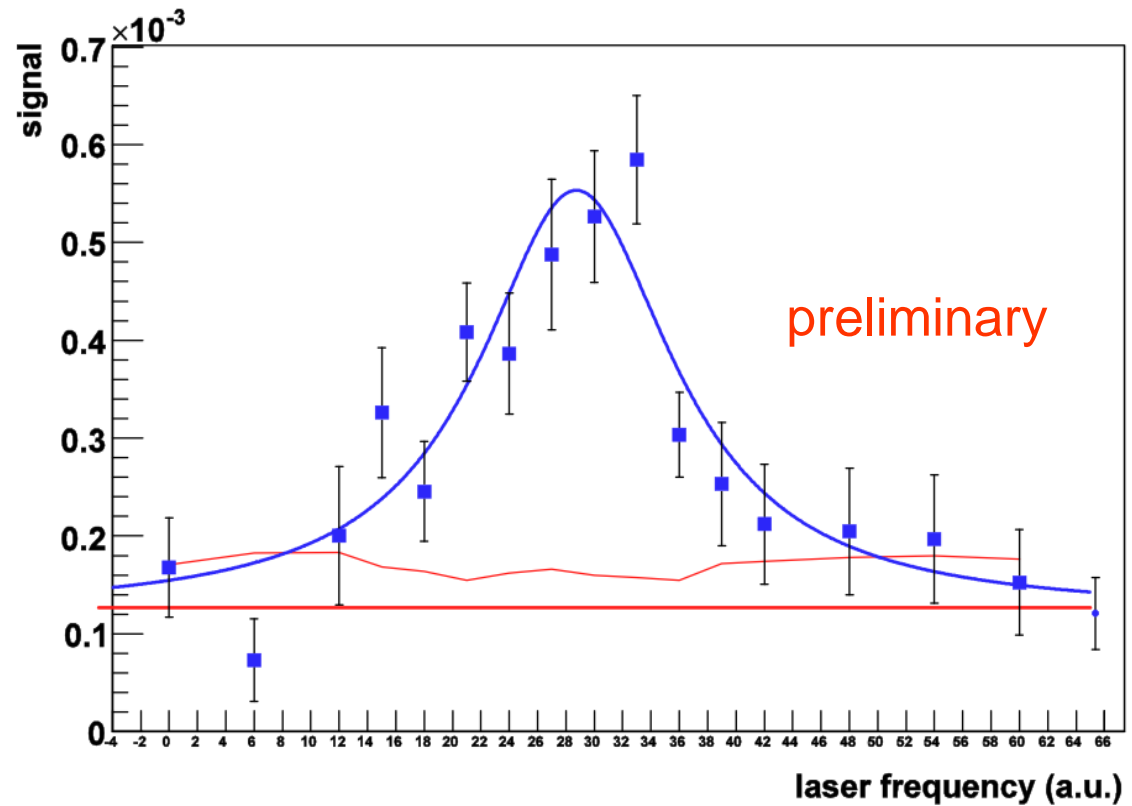

muonic deuterium : $^2S_{1/2}(F=3/2) - ^2P_{3/2}(F=5/2)$

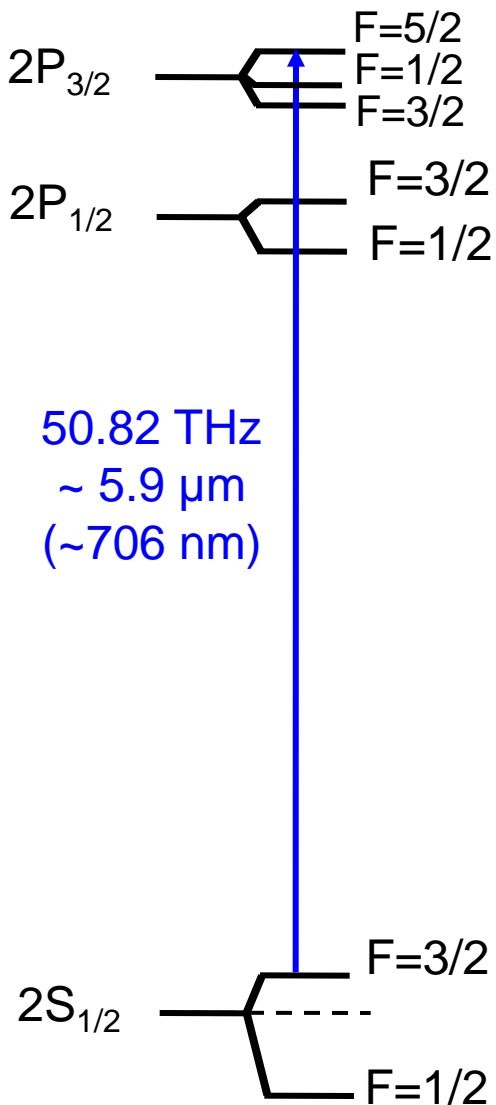

- on line signal, **preliminary**
- frequency position again off

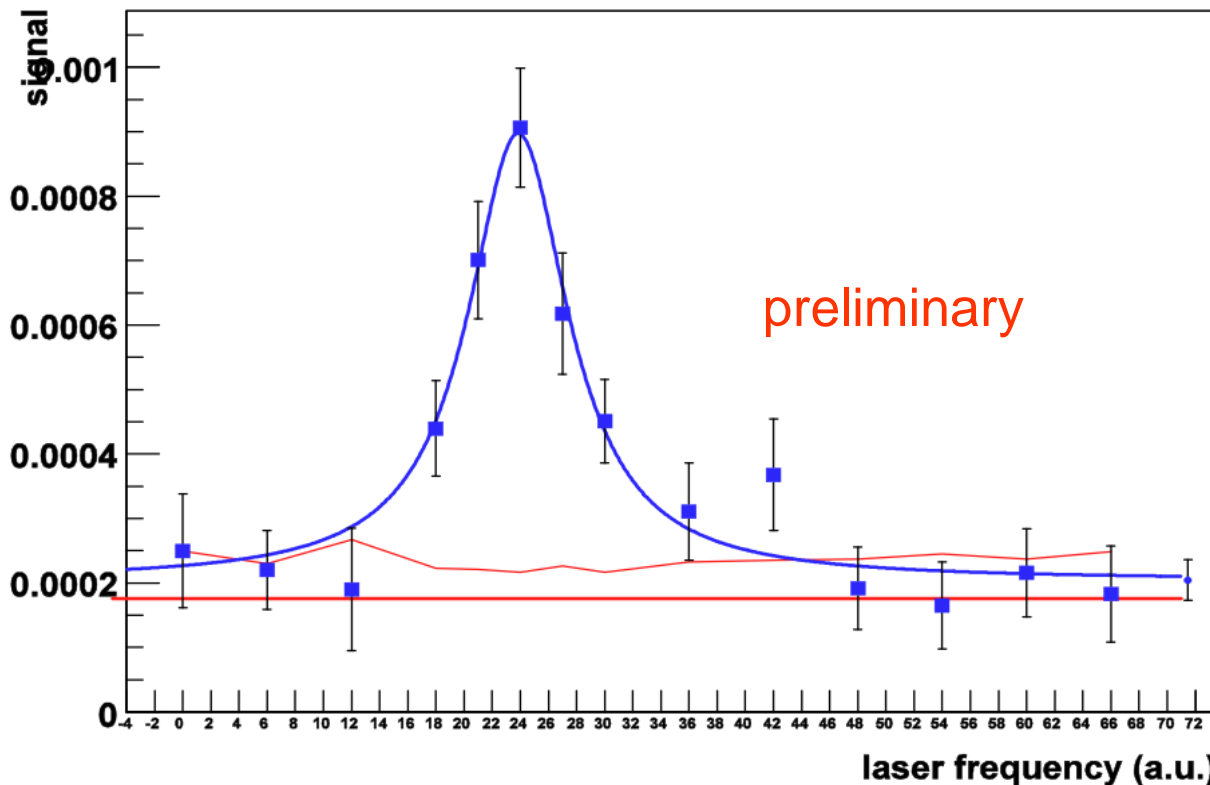

Not at the position estimated with new r_p and isotopic shift \square deuteron polarizability

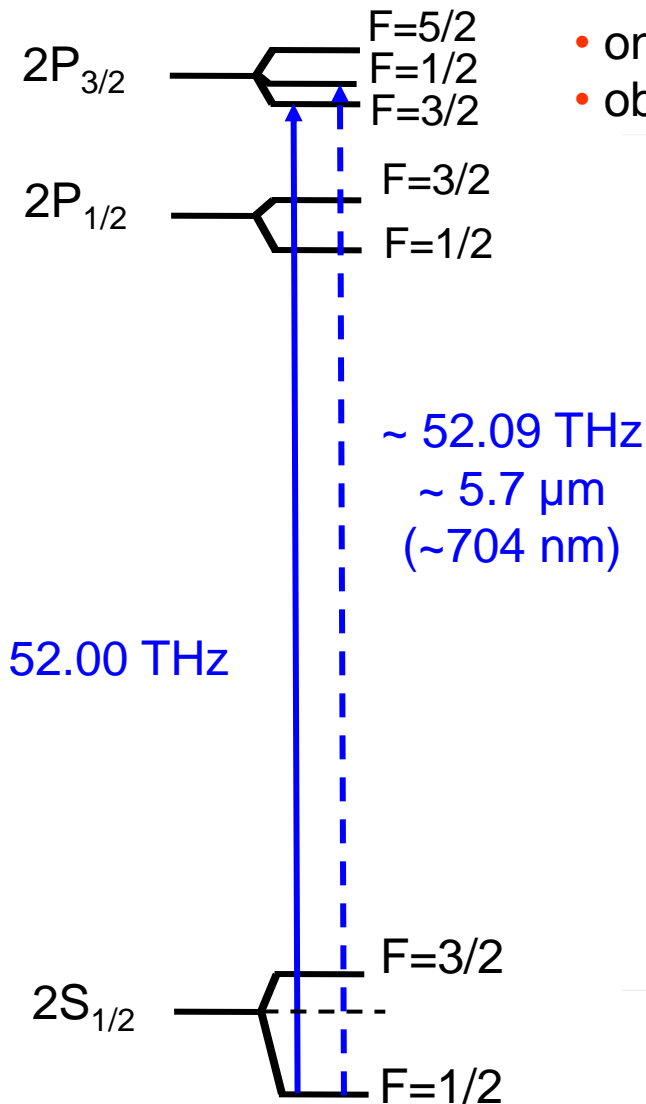

- on line signal, **preliminary**
- observation of 2 more lines in the last 2 days of beam line

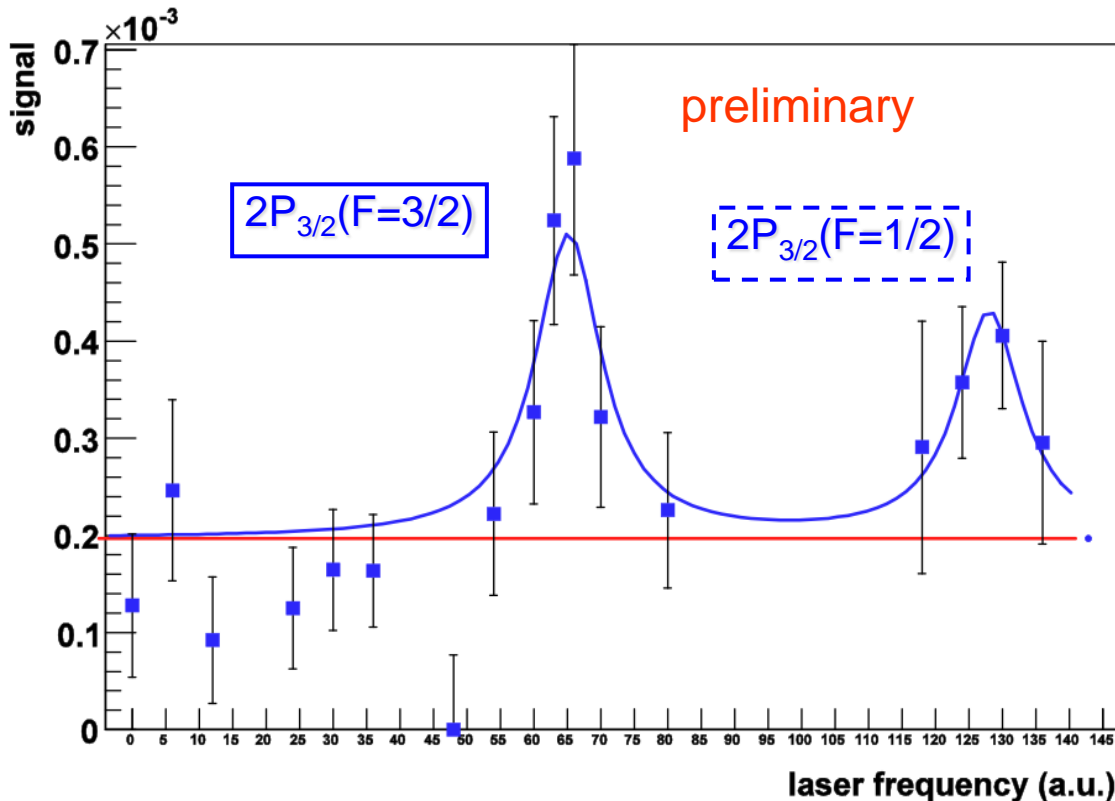

“observation” check calculation in μd

FSR measured/controlled in cw with I₂ (1 ph abs), Cs (2 ph fluo), Rb (2 ph fluo), lines

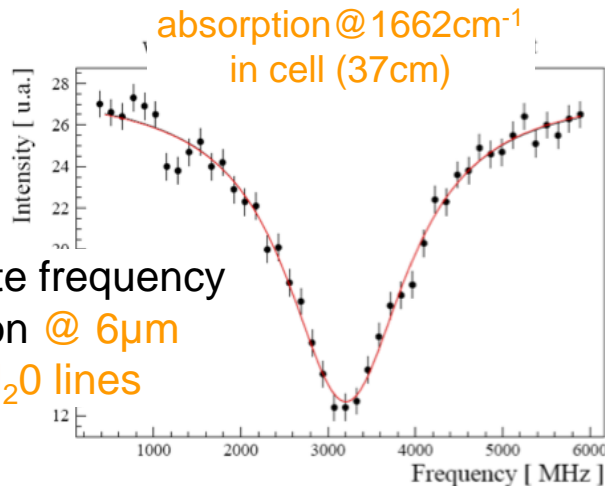
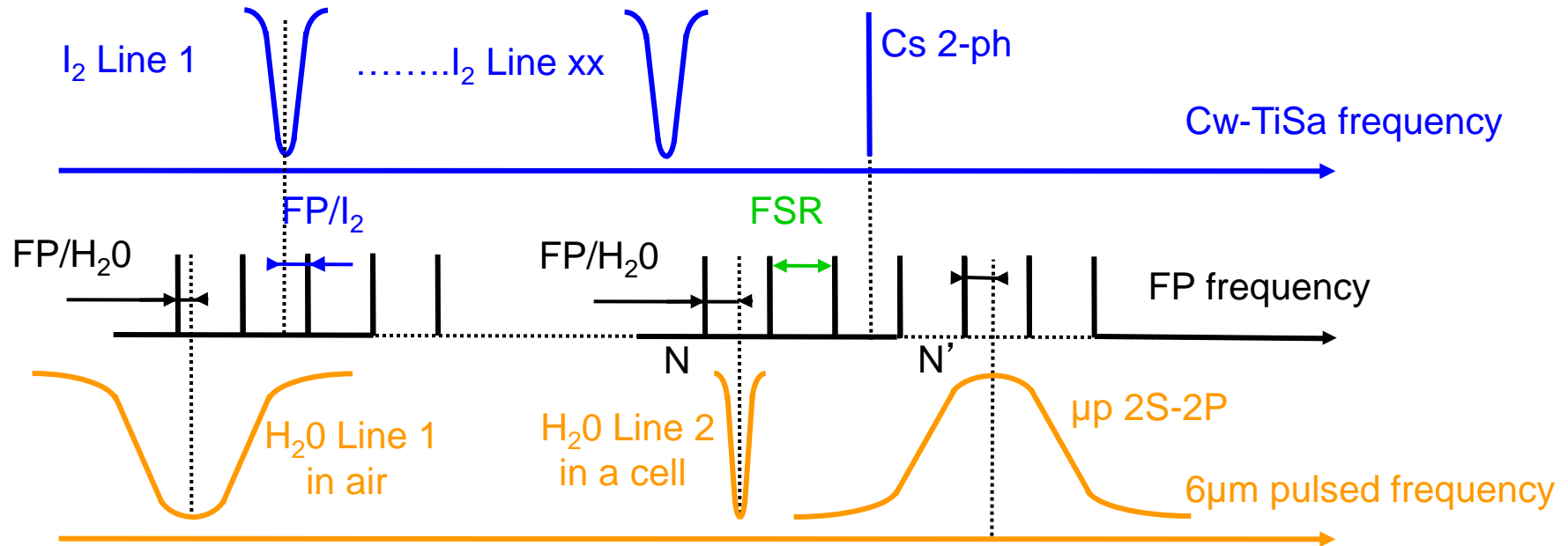

$$\{ (\mu\text{p}:2\text{S}-2\text{P}) \} = \{ (\text{H}_2\text{O Line 2}) \} + (\text{N}-\text{N}') \text{ FSR}$$

FP absolute frequency
calibration @ 6µm
with H₂O lines

- 2010 CODATA value uses improved theory for hydrogen and Mainz electron-proton scattering is now at 6.9σ mostly by a reduction of σ :
 - 0.8775 (59) fm 2010
 - 0.8768 (69) fm 2006
- We have analyzed in details the second transition that was observed, using an improved algorithm that correct for the variation of the laser pulse energy from shot to shot
- We have reanalyzed the first observed line using the improved method
- This lead to a slightly reduced error bar for the first transition, an accurate value of a second transition which allows to
 - Get a measurement of the magnetic moment distribution mean radius
 - An improved charge radius

Statistics

- uncertainty on position (fit)

541

MHz ($\sim 3\%$ of δ_{nat})

$\delta_{\text{experimental}} = 20 (1) \text{ GHz}$ ($\delta_{\text{nat}} = 18.6 \text{ GHz}$)

Sources :

- Laser frequency (H_2O calibration, lines known to $\sim 1 \text{ MHz}$)

300 MHz

- AC and DC stark shift

< 1

MHz

- Zeeman shift (5 Telsa)

< 30

MHz

- Doppler shift

< 1 MHz

- Collisional shift

2 MHz

TOTAL UNCERTAINTY ON FREQUENCY

618 MHz

Υπόλοιπο: } ($\mu\text{P} : {}^2\text{S}_{1/2}(F=1) - {}^2\text{P}_{3/2}(F=2)$) $< 1\sigma$ (12.5 ppm)

Broadening: } ($\mu\text{P} : {}^2\text{S}_{1/2}(F=1) - {}^2\text{P}_{3/2}(F=2)$) = 49 881.88 (76) GHz (16 ppm)

- 6 μm laser line width $\sim 2 \text{ GHz}$

- Doppler Broadening < 1 GHz

- Collisional broadening 2.4 MHz

Statistics

- uncertainty on position (fit)

960 MHz

Sources :

- Laser frequency (H_2O calibration)
- AC and DC stark shift
- Zeeman shift (5 Telsa)
- Doppler shift

300 MHz

< 1 MHz

< 30 MHz

< 1

MHz

- Collisional shift

2

MHz

TOTAL UNCERTAINTY ON FREQUENCY

1006 MHz

Broadening :

- 6 μm laser line width
- Doppler Broadening
- Collisional broadening

~ 2 GHz

< 1 GHz

2.4 MHz

$\mu\text{P} : ^2\text{S}_{1/2}(F=0) - ^2\text{P}_{3/2}(F=1)$ good agreement with the other

(18.5ppm)

Discrepancy=0.31 meV
 Th. uncertainty=0.005 meV
 $\implies 60\delta(\text{theory})$ deviation

Main contributions to the μp Lamb shift

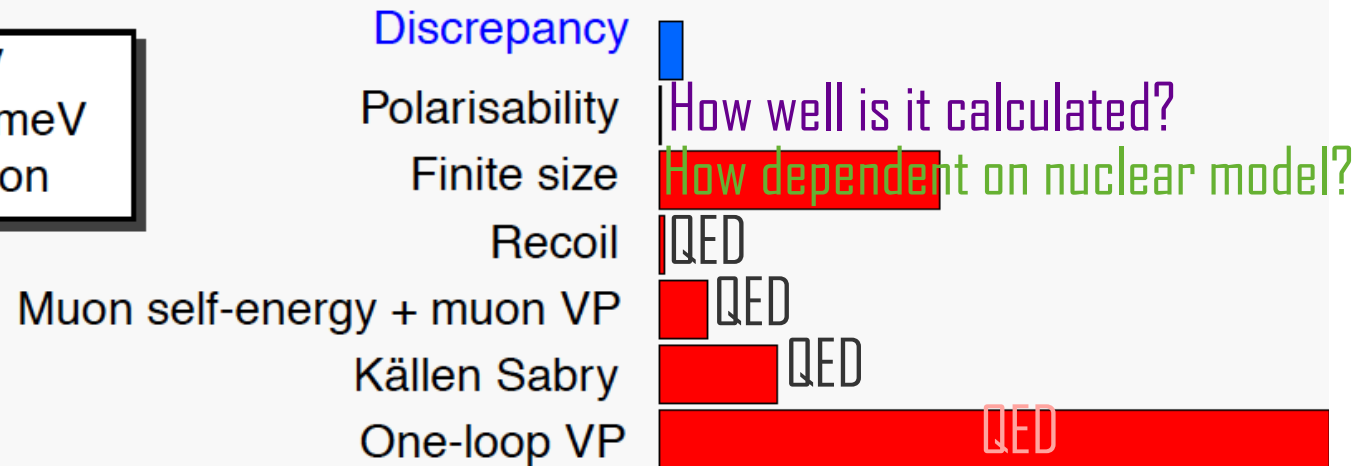

■ The two **measured** lines obey to:

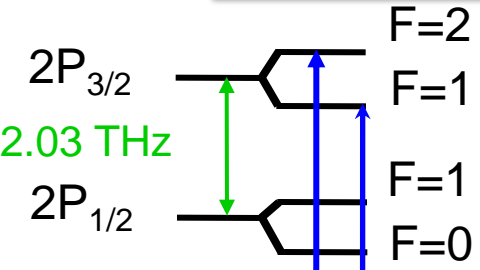

$$E_{5P_{3/2}} - E_{3S_{1/2}} = \Delta E_{LS} + \Delta E_{FS} + \frac{3}{8}\Delta E_{HFS}(2p_{3/2}) - \frac{1}{4}\Delta E_{HFS}(2s)$$

$$E_{3P_{3/2}} - E_{1S_{1/2}} = \Delta E_{LS} + \Delta E_{FS} - \frac{5}{8}\Delta E_{HFS}(2p_{3/2}) + \frac{3}{4}\Delta E_{HFS}(2s)$$

49.81 THz
~ 6 μm
(~708 nm)

finite size
0.96 THz

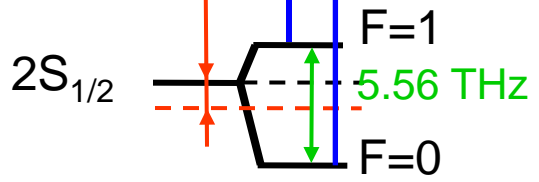

$$\langle R_{Z,a,b}^n \rangle = \int d^3r_1 d^3r_2 \rho_a(r_1) \rho_b(r_2) |\mathbf{r}_1 - \mathbf{r}_2|^n$$

$$\Delta E_{\text{HFS}} = E_F \left(1 - 2\alpha m_\mu \langle r_{Z,e,m}^1 \rangle \right)$$

$$\rho_{em}(\mathbf{r}) = \int \rho(\mathbf{r} - \mathbf{u}) \mu(\mathbf{u}) d\mathbf{u}$$

$$R_Z = \langle r_Z \rangle = \int r \rho_{em}(\mathbf{r}) d\mathbf{r}.$$

Using the **Dipole model** for the charge distribution

$$\langle R_{Z,e,e}^3 \rangle^2 = \frac{3675}{256} [\langle r^2 \rangle]^3$$

$$\Delta\tilde{E} = 209.9779(49) - 5.2262 r_p^2 + 0.0347 r_p^3 \text{ meV} \quad 0.84184(67) \text{ fm}$$

R. Pohl, A. Antognini, F. Nez, et al., Nature **466**, 213 (2010).

$$E_{\text{th}} = \left(209.9974(48) - 5.2262 \frac{r_p^2}{\text{fm}^2} \right) \text{ meV.} \quad 0.84169(66) \text{ fm.}$$

U. D. Jentschura, Annals of Physics **326**, 500 (2011).

$$E_{5P_{3/2}} - E_{3S_{1/2}} = 209.9759 - 5.22888R^2 + 0.0357376R^3 - 0.000045R^4$$

Non-perturbative: P. Indelicato, P. Mohr, to be published

$$0.84145(66) \text{ fm}$$

$$209.9505 - 5.2345\langle r_p^2 \rangle + 0.0361\langle r_p^2 \rangle^{3/2} :$$

$$\text{present work } \sqrt{\langle r_p^2 \rangle} = 0.83811(67) \text{ fm.}$$

Non-perturbative: J. D. Carroll, A. W. Thomas, J. Rafelski, et al., Phys. Rev. A **84**, 012506 (2011).

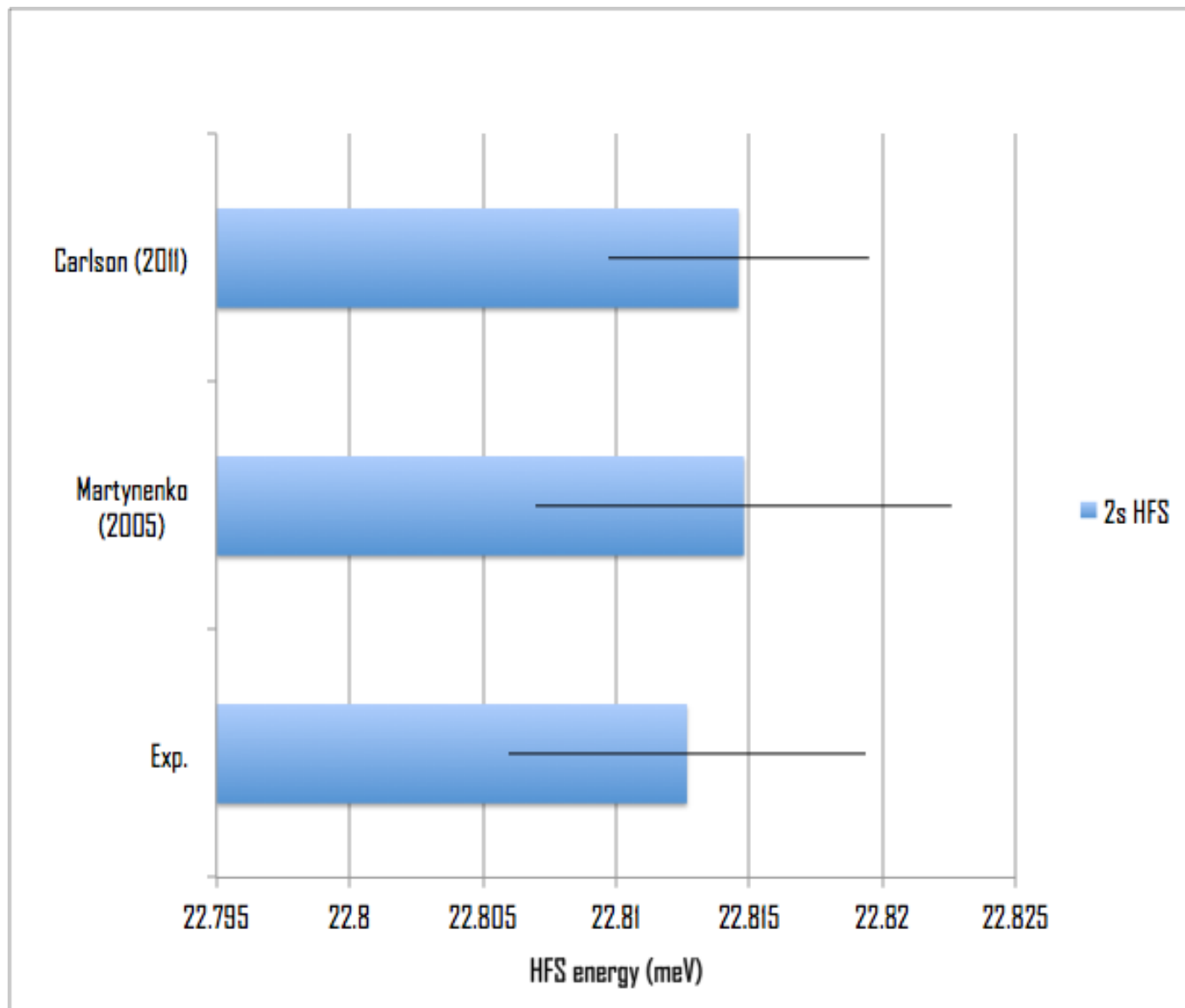

Other measurements

How to get the radius from hydrogen

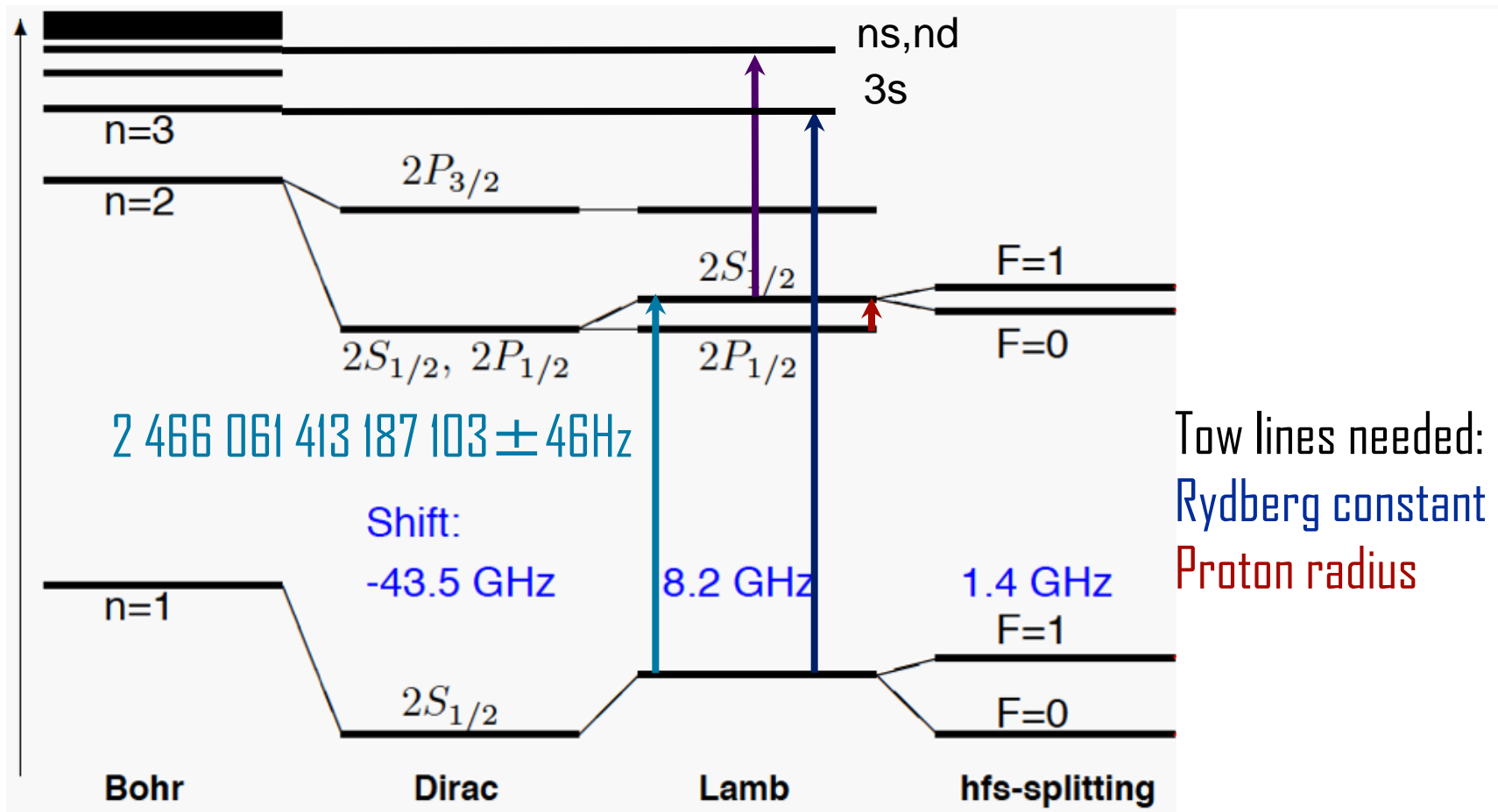

Analysis by F. Biraben

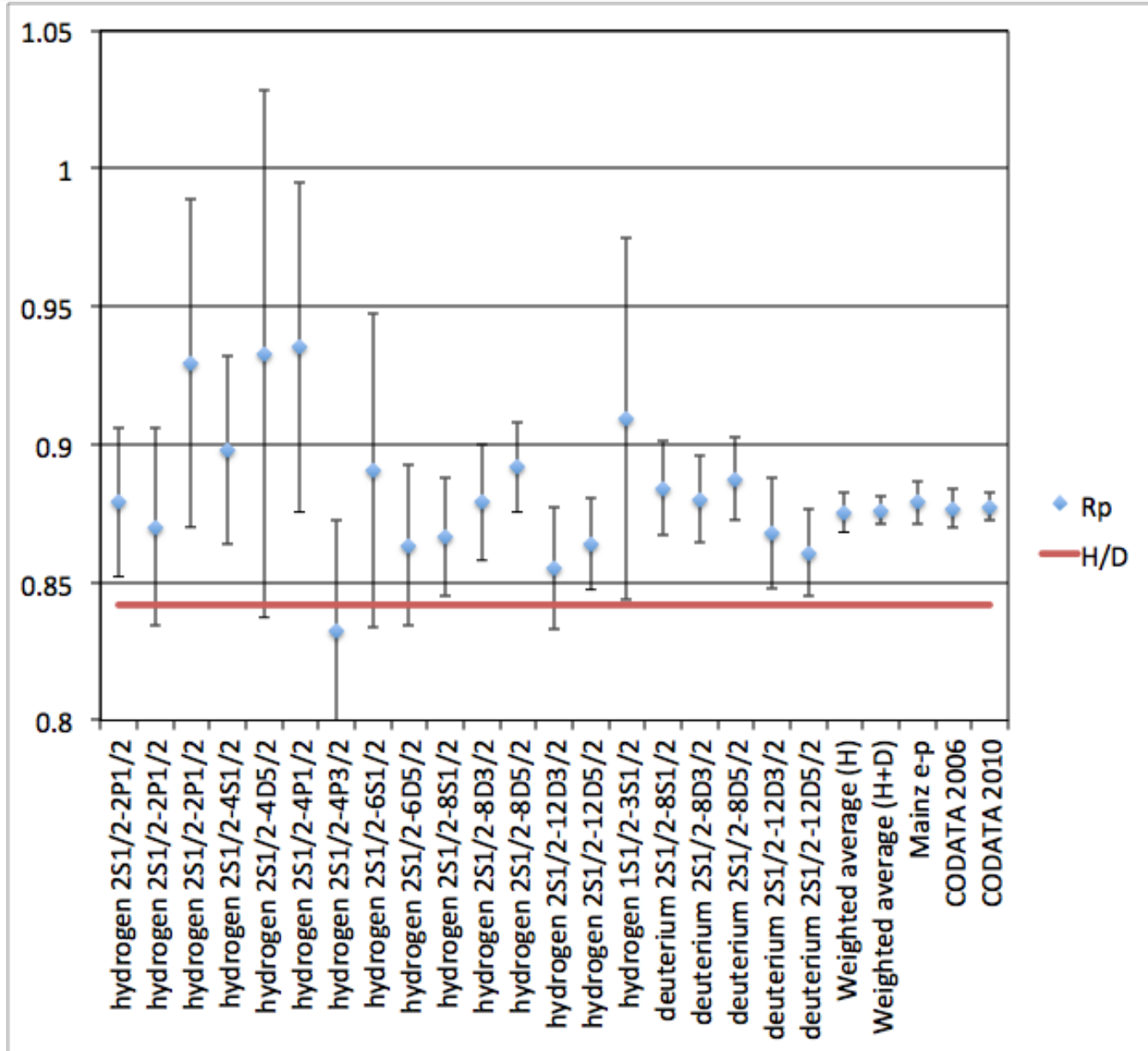

Proton size results summary

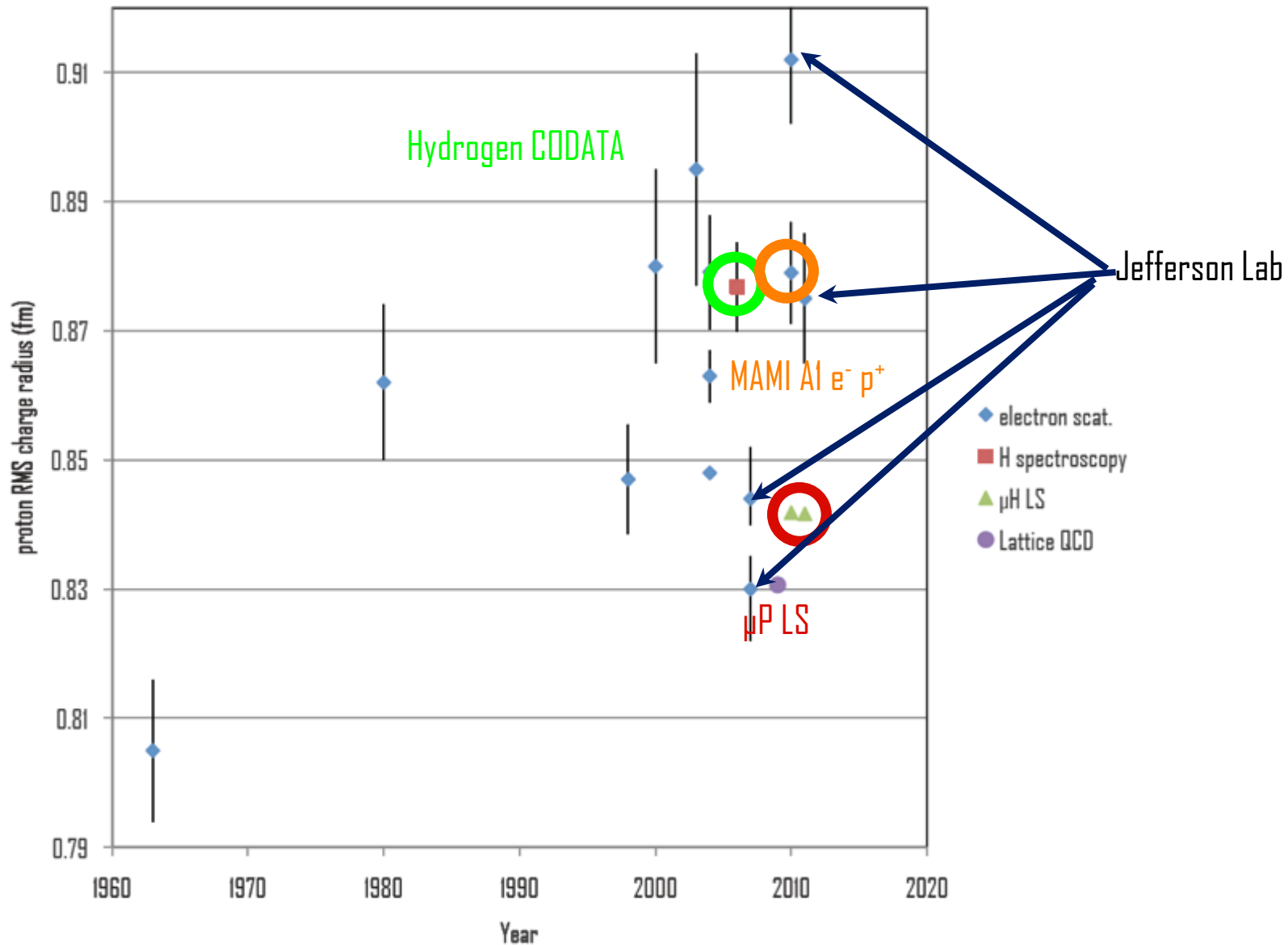

- QED → not likely at the moment (many checks performed)
- Proton polarization (strong discussion going on)
- Electron-proton elastic scattering data analysis
- Under-estimated systematic errors in some hydrogen measurements
 - possible, but many different kind of experiments (microwave, $1s-3s$, $2s-n_s$ and $2s-nd$)
- New physics
 - Constraints:
 - $g-2$ of the muon (3σ),
 - $g-2$ of the electron (Harvard)+fine structure constant from atomic recoil (LKB)
 - Hydrogen
 - ...

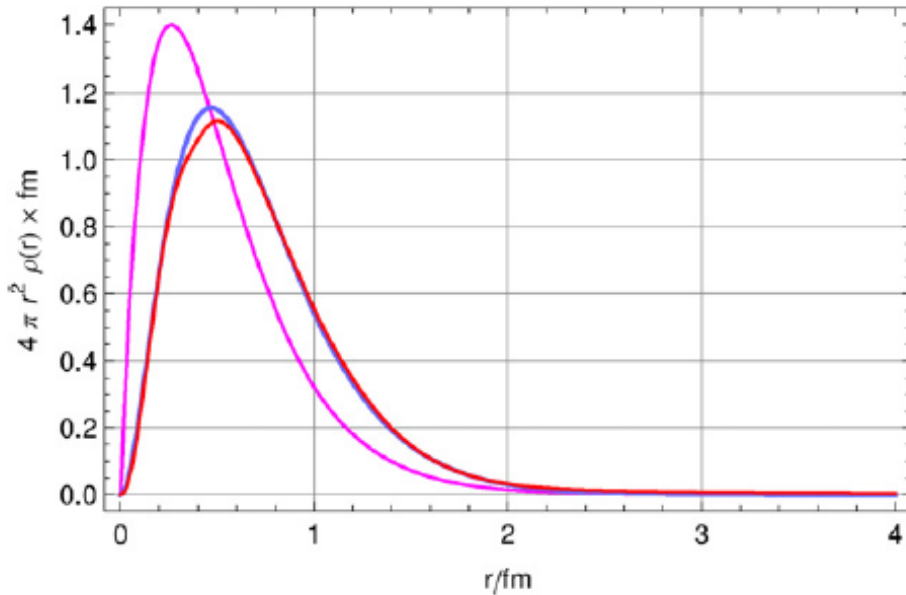

- $\langle r^3 \rangle_{(2)} = 3.789 \quad \langle r^2 \rangle^{3/2}$ Dipole
- $\langle r^3 \rangle_{(2)} = 1.960 \quad \langle r^2 \rangle^{3/2}$ Gauss
- $\langle r^3 \rangle_{(2)} = 3.91 \quad \langle r^2 \rangle^{3/2}$ Arrington (2007)
- $\langle r^3 \rangle_{(2)} = 3.78(13) \quad \langle r^2 \rangle^{3/2}$ Friar & Sick (2005)
- $\langle r^3 \rangle_{(2)} = 4.18(13) \quad \langle r^2 \rangle^{3/2}$ Distler, Bernauer, Walcher (2011)
- $\langle r^3 \rangle_{(2)} = 36.6 \pm 7.3 = 51 \quad \langle r^2 \rangle^{3/2}$ De Rújula (2010), retracted (?) in 2011...

[1] QED is not endangered by the proton's size, A. De Rújula. Physics Letters B 693, 555-558 (2010)

[2] QED confronts the radius of the proton, A. De Rújula. Physics Letters B 697, 26-31 (2011)

[3] The RMS charge radius of the proton and Zemach moments, M.O. Distler, J.C. Bernauer et T. Walcher. Physics Letters B 696, 343-347 (2011)..

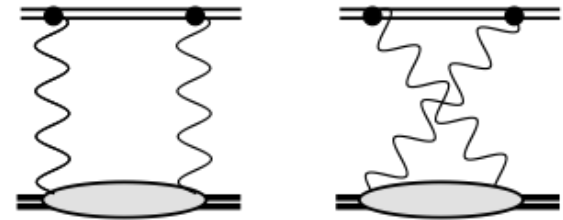

$$\Delta E_{2s}^{\text{p.pol}} = -\frac{136 \pm 30}{n^3} \mu\text{eV} = -0.017 \pm 0.004 \text{ meV.}$$

$$\Delta E_{2s}^{\text{p.pol}} = -0.012 \pm 0.002 \text{ meV,}$$

$$\begin{aligned} \Delta E_{2s}^{\text{p.pol}} &= \Delta E^{\text{subt.}} + \Delta E^{\text{inel.}} \\ &= 0.0023 - 0.01613 \text{ meV} \\ &= -0.0138(29) \text{ meV,} \end{aligned}$$

$$\begin{aligned} \Delta E_{2s}^{\text{p.pol}} &= \Delta E^{\text{subt.}} + \Delta E^{\text{inel.}} + \Delta E^{\text{el.}} \\ &= 0.0053(19) - 0.0127(5) - 0.0295(13) \text{ meV} \\ &= -0.0074(20) - 0.0295(13) \text{ meV.} \end{aligned}$$

$$\begin{aligned} \Delta E_{2s}^{\text{p.pol}} &= \Delta E^{\text{subt.}} + \Delta E^{\text{inel.}} \\ &= [\delta E^{W_1(0,Q^2)} + \delta E^{\text{proton pole}}] + \delta E^{\text{continuum}} \\ &\Rightarrow [\delta E^{W_1(0,Q^2)} + 0016] - 0.0127(5) \text{ meV,} \end{aligned}$$

Could be wrong by 0.04 meV



What's next

Deuterium: deuteron polarization very large
Helium?

812 nm
 $\rho_{\text{He}} = 40 \text{ bars}$

2011-2013 muonic helium spectroscopy (4 mbar)

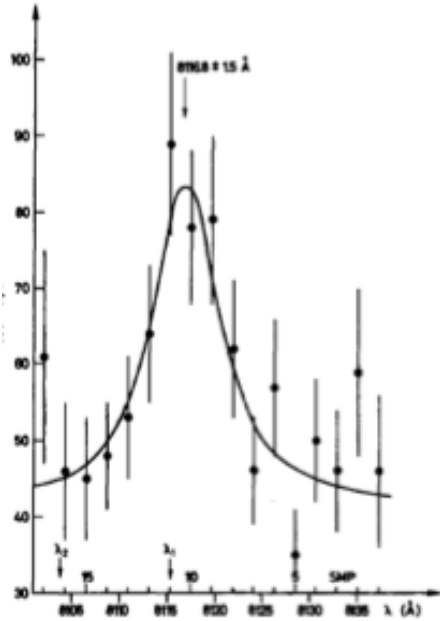

Nuclear Physics A278 (1977) p. 381

but signal never reproduced
 (10 bars, 40 bars)

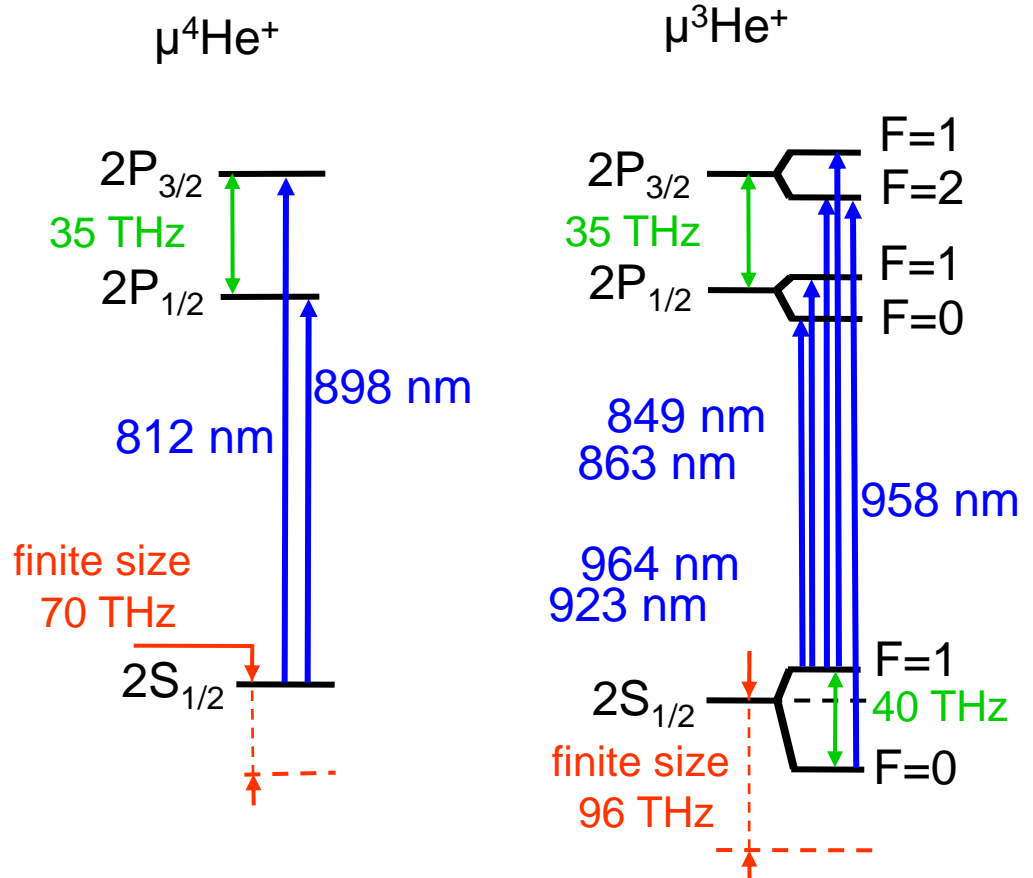

- μHe^+ spectroscopy + He^+ spectroscopy QED test ($Z \langle \dots \rangle$)
- improve He spectroscopy

- We have performed a 12.5 ppm measurement of the Lamb-shift in muonic hydrogen
- The deduced proton radius using a Dipole model is 6.9 standard deviations away from the hydrogen and electron-proton elastic scattering data
- Better modeling of the proton form-factor and polarization required to confirm or reduce the disagreement
- Experiment confirmed with 2nd μH line
- 3 μD lines observed and being analyzed
- Muonic He in 2013 (check of theory, different laser wavelength-in the red) predictions of measurable effects from new physics!!



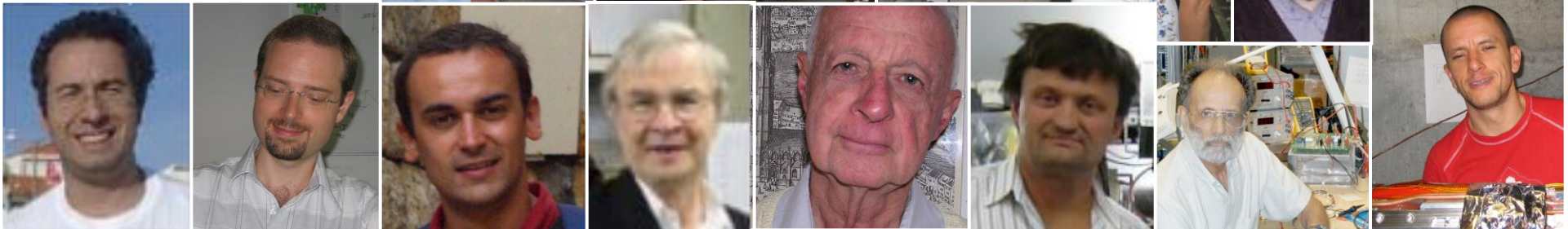

Proton Size Investigators thank you for your attention



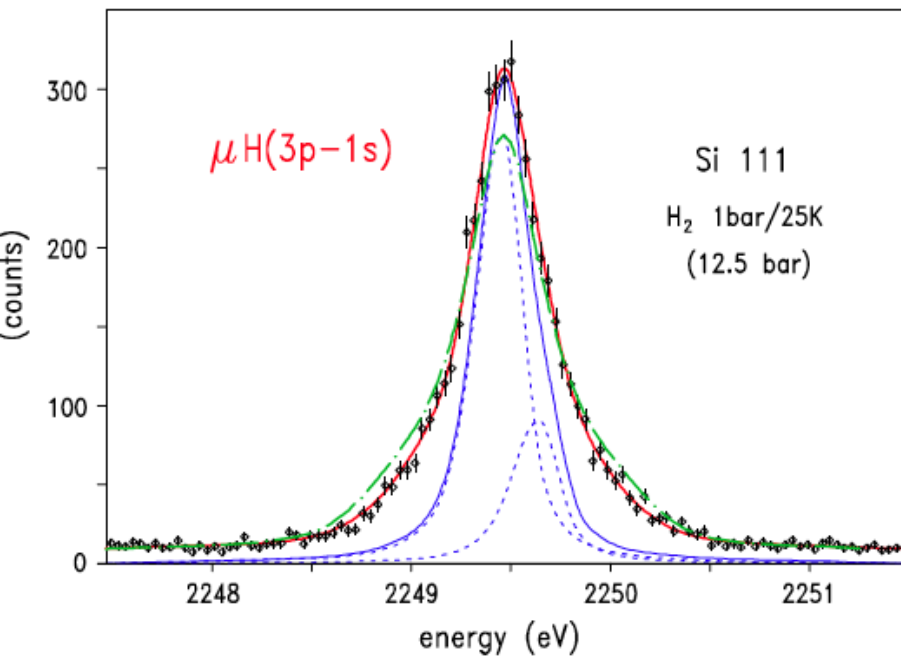

Line Shape of the mu H(3p-1s) Hyperfine Transitions,
D.S. Covita, D.F. Anagnostopoulos, H. Gorke, D. Gotta, A.
Gruber, A. Hirtl, T. Ishiwatari, [P. Indelicato](#), [E.-O.L.
Bigot](#), M. Nekipelov, J.M.F.d. Santos, P. Schmid, L.M.
Simons, M. Trassinelli, J.F.C.A. Veloso and J. Zmeskal.
Phys. Rev. Lett. 102, 023401 (2009).

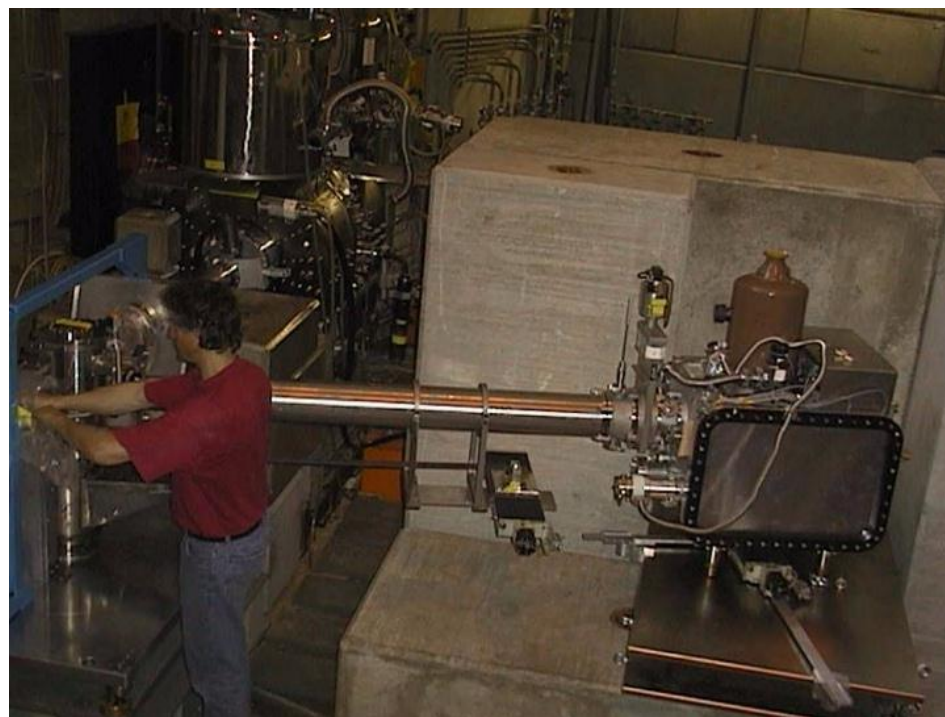

Laser chain : thin-disk Yb:YAG laser

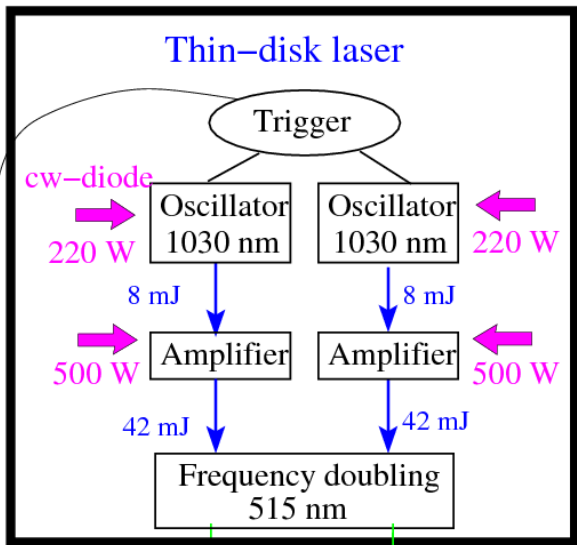

- Q-switch oscillator (cw prelasing mode □ short delay between electronic trigger and opt. output (8mJ, xxx ns, delay 250ns)
 - 12 pass amplifier (20m propagation) (42mJ)
 - LBO frequency doubling 25mJ @ 515nm
-
- 50 mJ @ 515 nm, reliable laser
 - delay electronic trigger/output pulse < 500ns
 - random trigger $\geq 1.5ms$

Disk oscillator

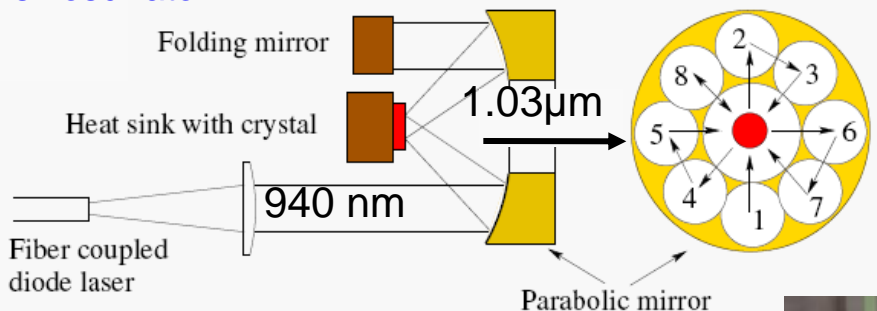

Disk amplifier

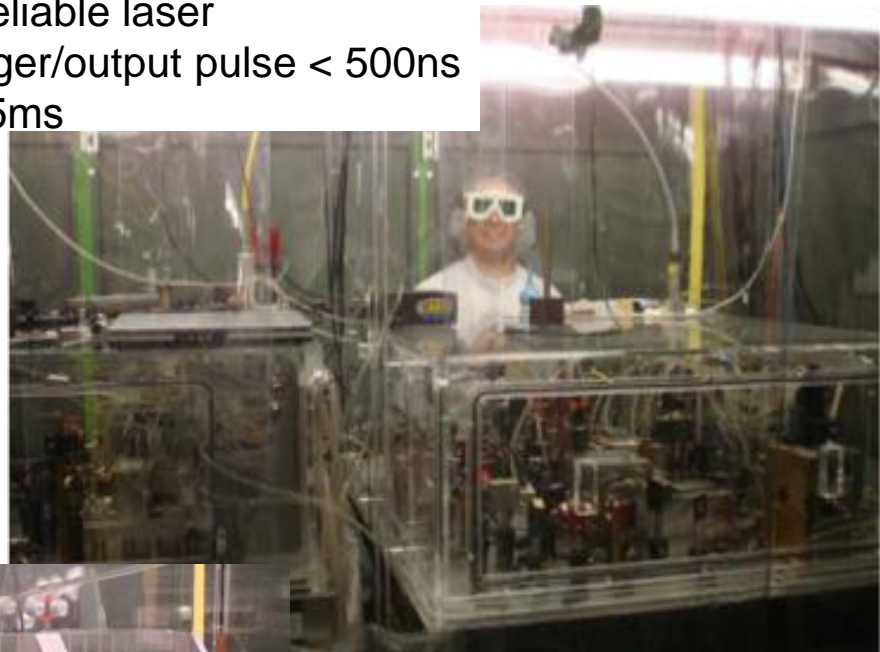
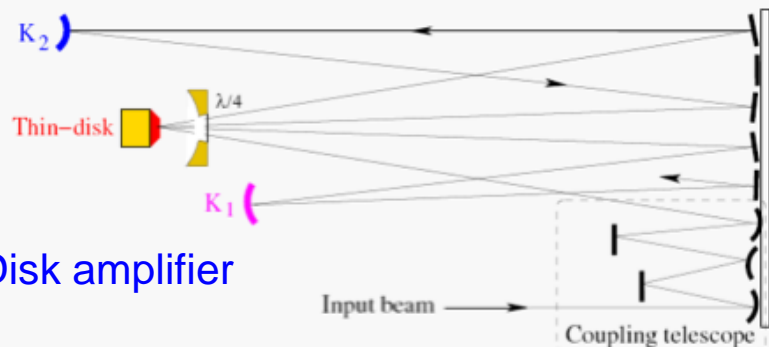

Laser chain : Ti:Sa

Calibration FP/ I₂, Cs, Rb (700-794nm)

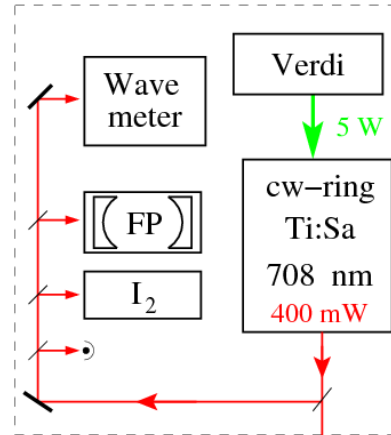
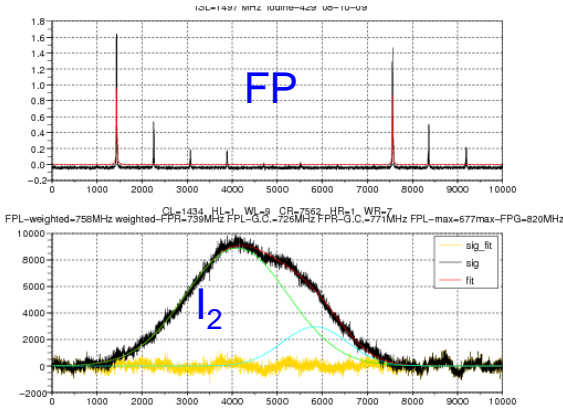

Frequencies of the FP peaks

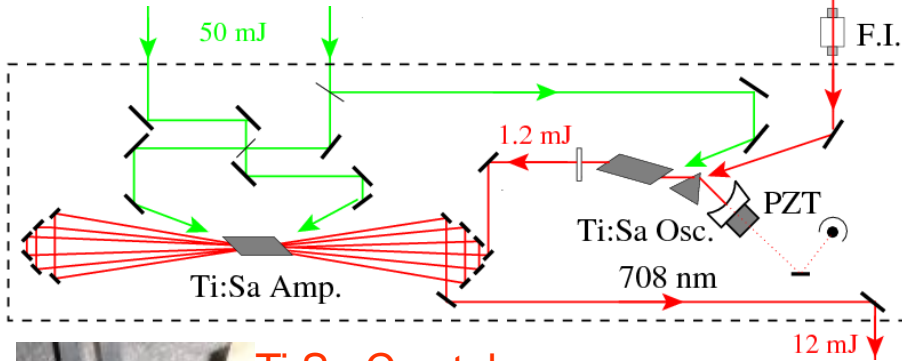
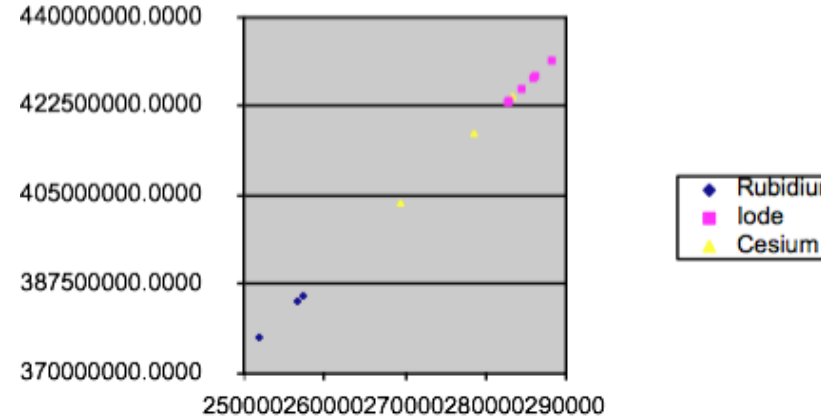

- home made Ti:Sa lasers
- cw-Ti:Sa frequency controlled with FP, atom, molecule (abs. freq. <50MHz)
- short length pulsed oscillator seeded with Cw-Ti:Sa (1.2 mJ, 6 ns, delay 50 ns, \otimes = 200MHz)
- multipass amplifier \sim 6 (12 mJ, 5 ns)

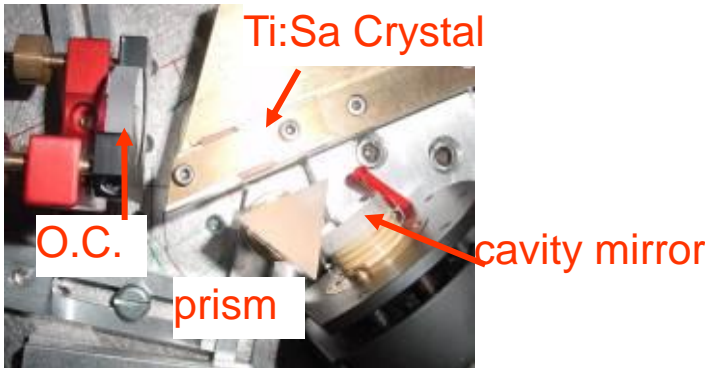

New physics

Predictions are always difficult, in particular about the Future
[N. Bohr]

- A muon edm? If $d_\mu = 2 \times 10^{-19}$ e·cm would shift the energy level < 200 MHz
- Charge equality between e^- and μ^- generation? Checked to $u_r = 10^{-8}$ (from μ^+e^-)
- Deviation from Coulomb's law: probe of hidden sector

- Test of Coulomb law via spectroscopy is very clean and model independent probe of new particles
It is independent on stability and decay channel.

$$V(r) = -\frac{Z\alpha}{r}(1 + \alpha'e^{-mr}) \quad \text{or} \quad V(r) = -\frac{Z\alpha}{r}(1 + \alpha''(\mathbf{s}_1 \cdot \mathbf{s}_2)e^{-mr})$$

- From simple atoms there are constraints on light bosons with ultra-weak coupling:

$$m \in [1\text{eV}, \text{MeV}] \text{ and } \alpha' < 10^{-13}, \alpha'' < 10^{-17} \quad [\text{PRL } 104, 220406 \text{ (2010), arXiv:1008.3536v2}]$$

- Minicharge particles? [Jaeckel and Roy (2010), Jentschura(2010)]

Vacuum polarization with pair production of light fermions with $q = \epsilon e$ and masses $m_\epsilon < m_e$

No parameter found explaining r_p puzzle without contradicting, simple atoms spectroscopy, $g_e/\mu - 2$, $\alpha...$

- New bound-state QED theory?

- Non-local in time interaction...(R. K. Gainutdinov)?

Proton Size Anomaly, V. Barger, C.-W. Chiang, W.-Y. Keung et al. Phys. Rev. Lett. 106, 153001 (2011):

We explore the possibility that new scalar, pseudoscalar, vector, and tensor flavor-conserving nonuniversal interactions may be responsible for the discrepancy. We consider exotic particles that, among leptons, couple preferentially to muons and mediate an attractive nucleon-muon interaction. We find that the many constraints from low energy data disfavor new spin-0, spin-1, and spin-2 particles as an explanation.

Muonic hydrogen and MeV forces, D. Tucker-Smith et I. Yavin. Physical Review D 83, 101702 (2011).

We explore the possibility that a new interaction between muons and protons is responsible for the discrepancy between the CODATA value of the proton-radius and the value deduced from the measurement of the Lamb shift in muonic hydrogen. We show that a new force carrier with roughly MeV-mass can account for the observed energy-shift as well as the discrepancy in the muon anomalous magnetic moment. However, measurements in other systems constrain the couplings to electrons and neutrons to be suppressed relative to the couplings to muons and protons, which seems challenging from a theoretical point of view. One can nevertheless make predictions for energy shifts in muonic deuterium, muonic helium, and true muonium under the assumption that the new particle couples dominantly to muons and protons.

Muonic hydrogen and MeV forces, D. Tucker-Smith et I. Yavin. Physical Review D 83, 101702 (2011).

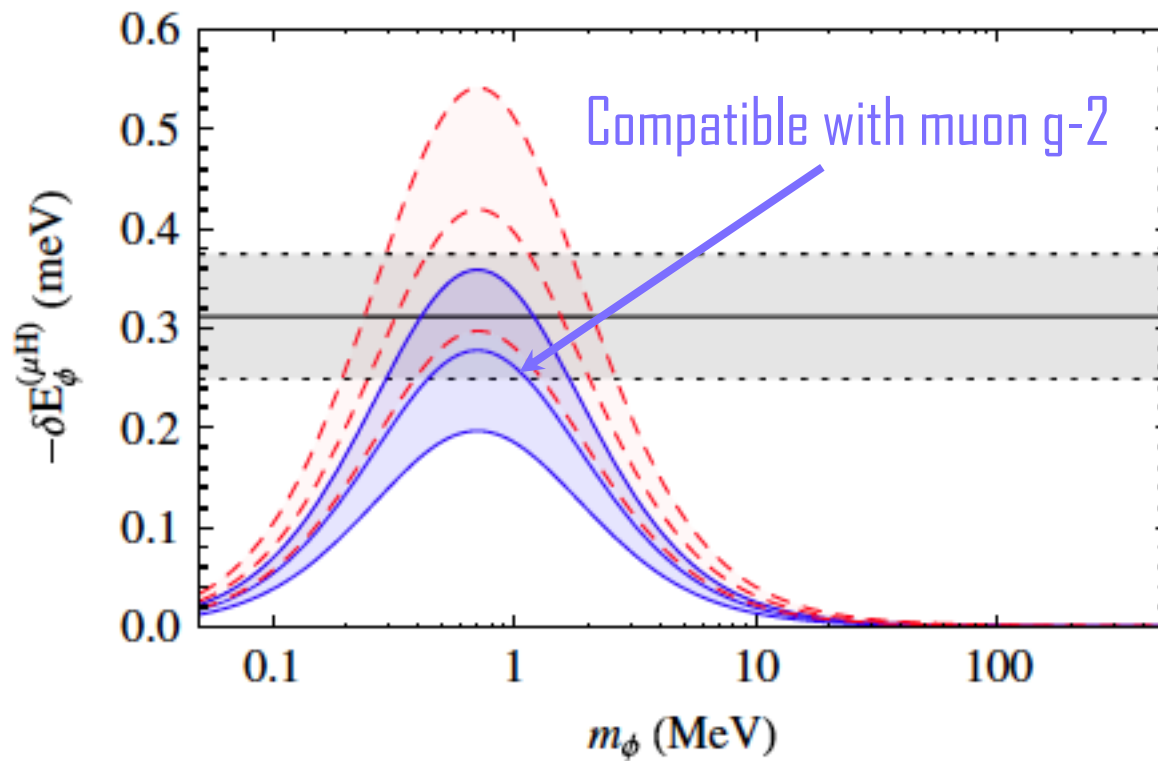

New Parity-Violating Muonic Forces and the Proton Charge Radius, B. Batell, D. McKeen et M. Pospelov. Phys. Rev. Lett. 107, 011803 (2011).

The recent discrepancy between proton charge radius measurements extracted from electron-proton versus muon-proton systems is suggestive of a new force that differentiates between lepton species. We identify a class of models with gauged right-handed muon number, which contains new vector and scalar force carriers at the 100 MeV scale or lighter, that is consistent with observations. Such forces would lead to an enhancement by several orders-of-magnitude of the parity-violating asymmetries in the scattering of low-energy muons on nuclei. The relatively large size of such asymmetries, $O(10^{-4})$, opens up the possibility for new tests of parity violation in neutral currents with existing low-energy muon beams.

B. Batell, D. McKeen, and M. Pospelov, Phys. Rev. Lett. 107, 011803 (2011).

$$\Delta r_p^2|_{e\text{-H}} = -\frac{6\kappa^2}{m_V^2}; \quad \Delta r_p^2|_{\mu\text{-H}} = -\frac{6(\kappa^2 + \eta)}{m_V^2} f(am_V) \quad (11)$$

where $a = (\alpha m_\mu m_p)^{-1}(m_\mu + m_p)$ is the μ -H Bohr radius, $f(\hat{x}) \equiv \hat{x}^4(1 + \hat{x})^{-4}$, and $\eta \equiv \kappa g_R/(2e)$. The difference $\Delta r_p^2|_{e\text{-H}} - \Delta r_p^2|_{\mu\text{-H}}$ must be consistent with the observed pattern (5) and requires η to be positive. In the scaling regime of $am_V \gg 1$ one has

$$\frac{\eta}{m_V^2} \simeq \frac{\Delta r^2}{6} \simeq 0.01 \text{ fm}^2 \simeq \frac{2.5 \times 10^{-5}}{(10 \text{ MeV})^2}. \quad (12)$$

In the same regime, the model predicts that future experiments with μ -He would detect the effective charge radius of the helium nucleus shifted down by $\Delta r_{\text{He}}^2 = -0.06 \text{ fm}^2$.