Accelerator Searches for Light Dark Matter

David Hitlin
Caltech
Tau 2023

Freeze-out Thermal Relics

The existence of dark matter is well-established by cosmological and astrophysics observations

The freeze-out hypothesis has been a key motivating concept in the search for dark matter

cosmological production

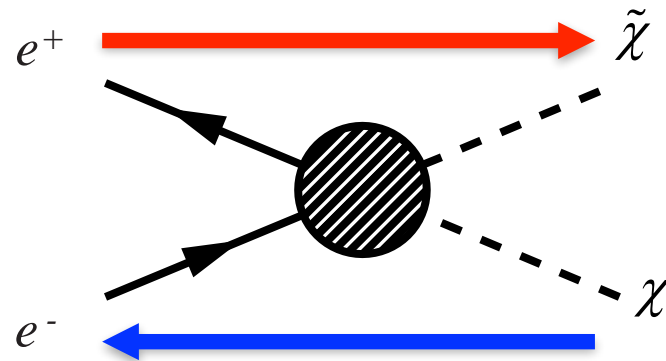

$$\sigma v = \frac{1}{16\pi^2} \frac{\bar{M}(s)}{s}$$

At freeze out:

$$s_{\text{fo}} \approx (2m_\chi)^2$$

$$\sigma v = 3 \cdot 10^{-26} \text{ cm}^3/\text{s}$$

$$\Rightarrow |\bar{M}(s_{\text{fo}})|^2 = 10^{-6} m_\chi^2 / \text{GeV}^2$$

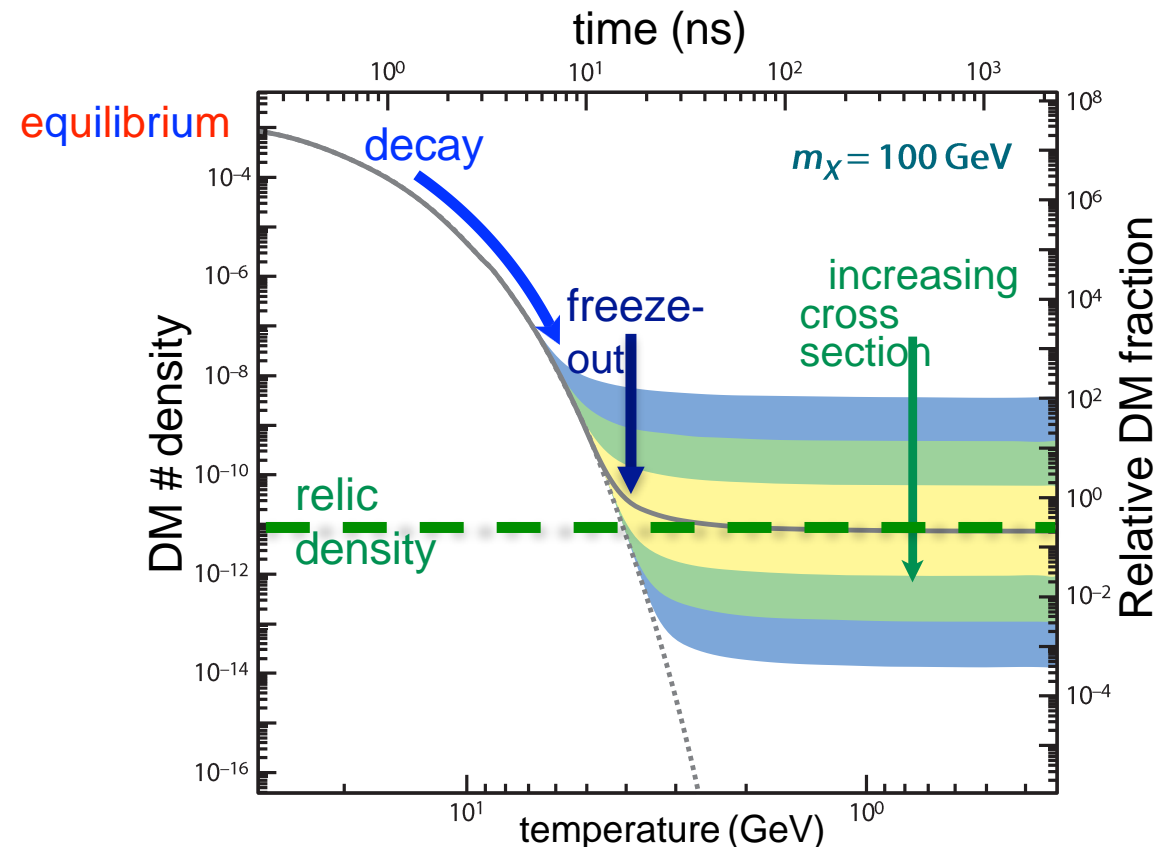

[Feng, Annu. Rev. Astron. Astrophys 48, 495 (2010)]

Detection of Freeze-out Thermal Relics

- The dark matter particle mass is a parameter; lighter masses require weaker couplings to visible SM
- The viable range for the freeze-out scenario encompasses the MeV to \sim TeV range

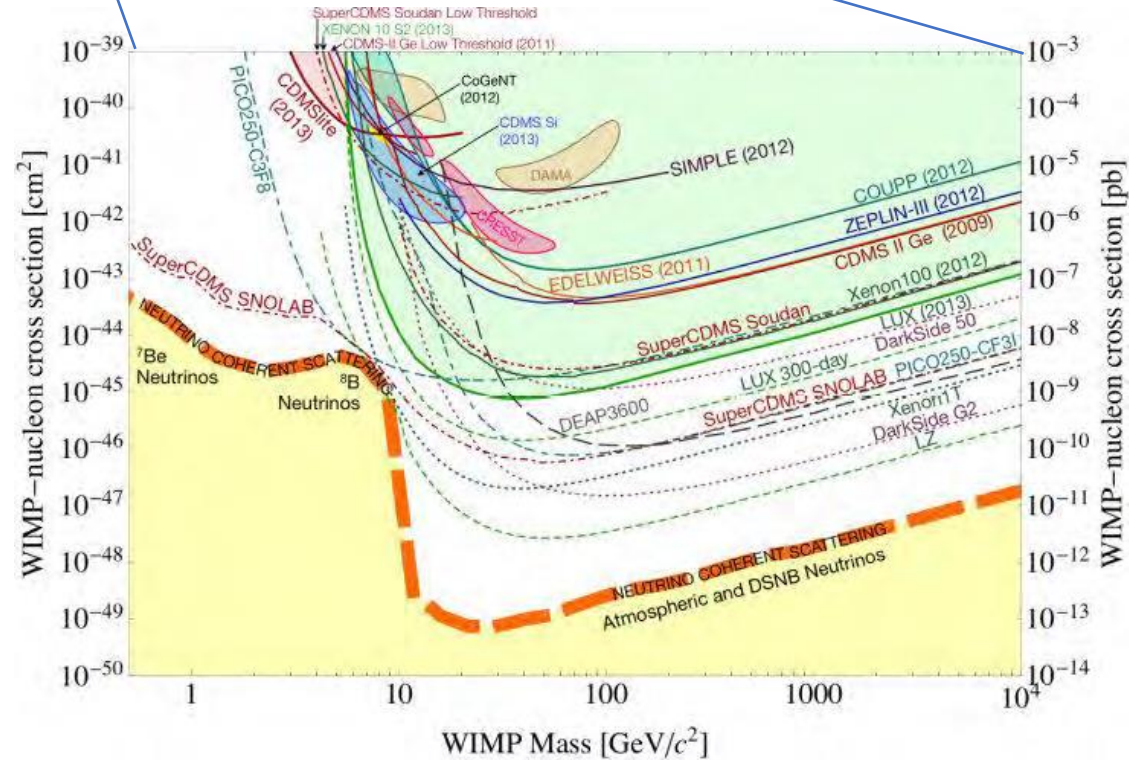
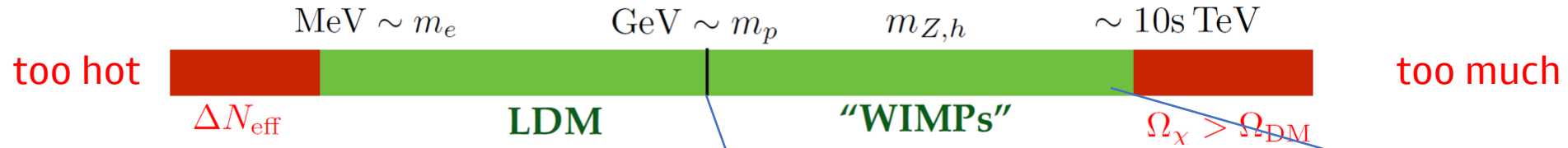

Detection of Freeze-out Thermal Relics

- The dark matter particle mass is a parameter; lighter masses require weaker couplings to visible SM
- The viable range for the freeze-out scenario encompasses the MeV to \sim TeV range

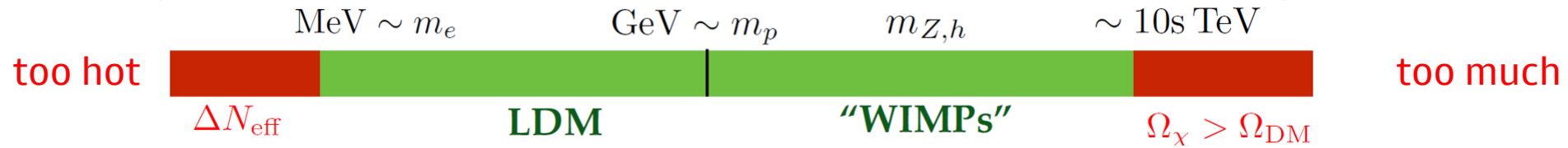

- Light dark matter naturally implies a new force carrier, e.g., a dark photon, to mediate the weak connection between the SM and DM sectors
- The observed DM relic abundance can be related to scattering cross sections
- **Direct-detection** requires experimental observation of non-relativistic dark matter
 - Sensitive to the details of the coupling, which can result in very large scattering rate suppression
- **Accelerator-based production** of dark matter moves the production to the relativistic regime, where the thermal target for freeze-in naturally collapses to a narrow mass band and there is no velocity suppression

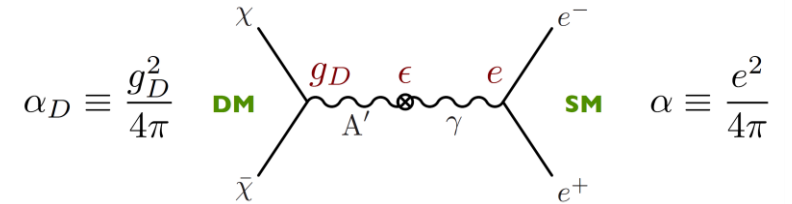

Concrete Example: Dark Photon Mediator

Thermal targets for DM- e scattering

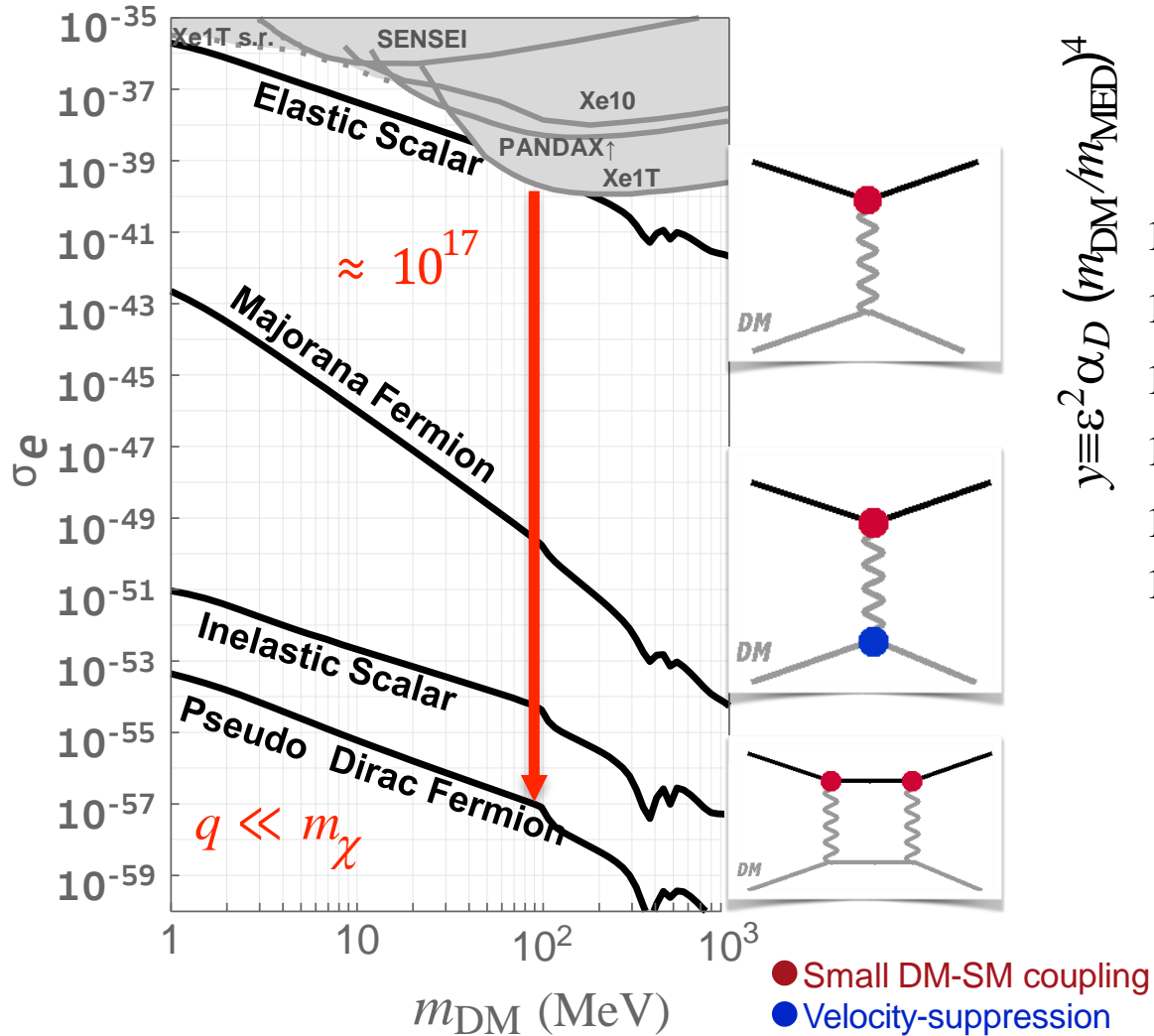

Thermal and Asymmetric Targets at Accelerators

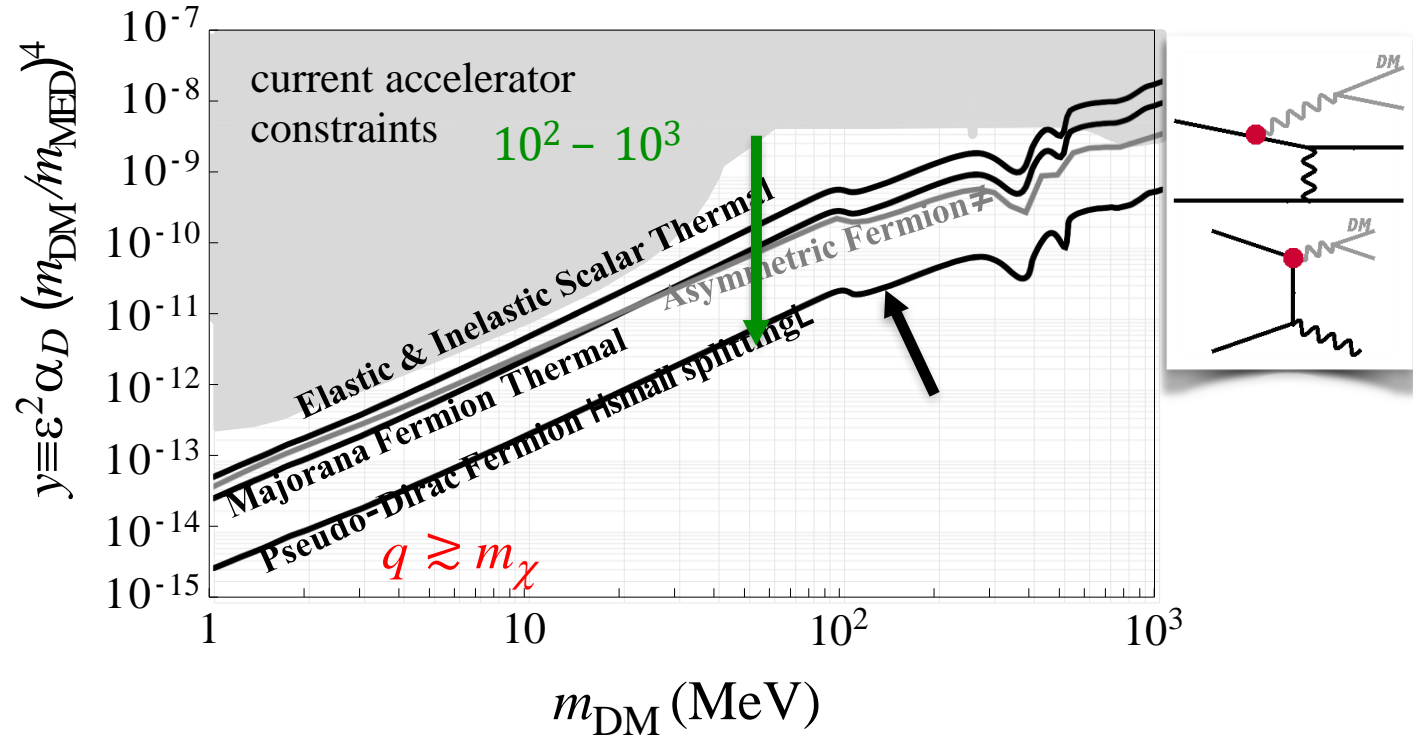

$$\sigma v \propto \epsilon^2 \alpha_D \frac{m_\chi^2}{m_{A'}^4} \equiv \frac{y}{m_\chi^2}$$

Dark Matter New Initiatives Basic Research Needs PRD 1

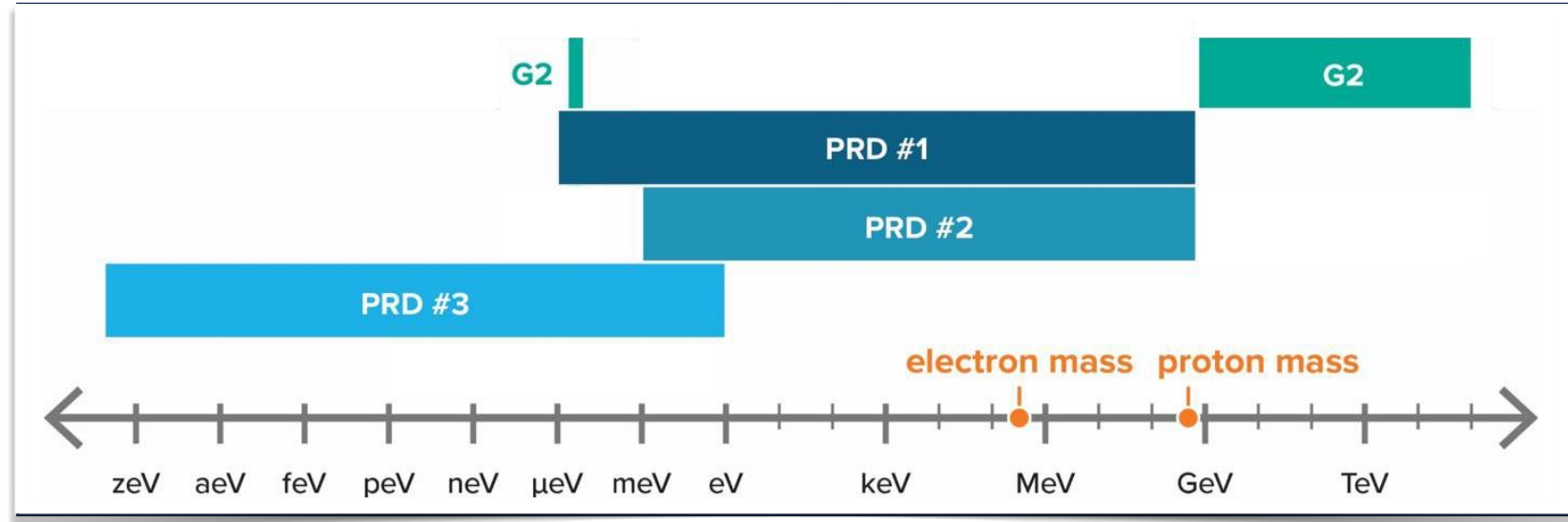
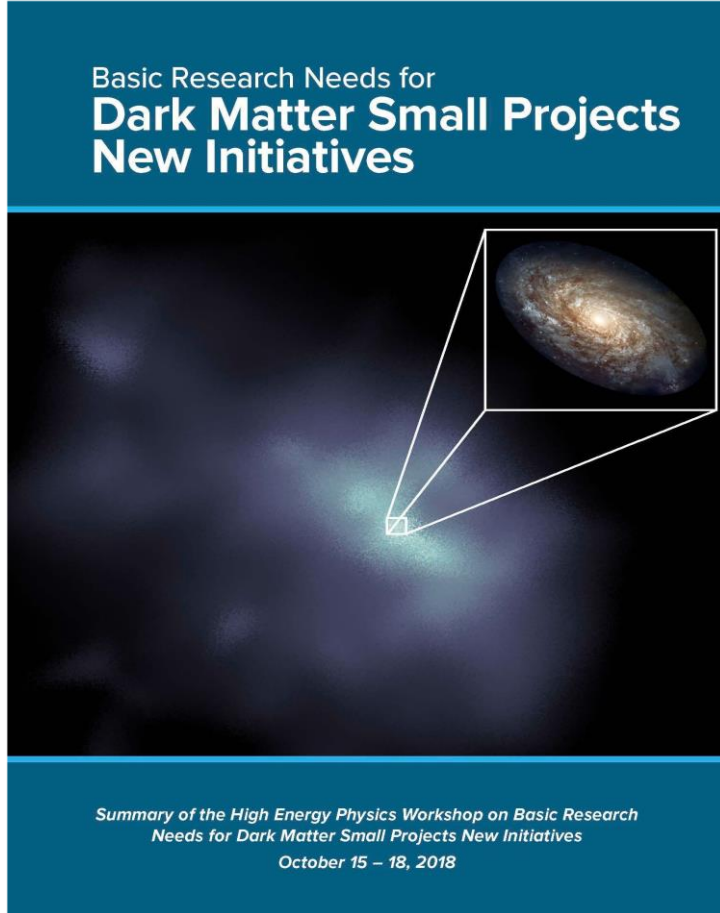

PRD 1: Create and detect dark matter particles below the proton mass and associated forces, leveraging DOE accelerators that produce beams of energetic particles.

**Create & Detect
Dark Matter
at Accelerators**

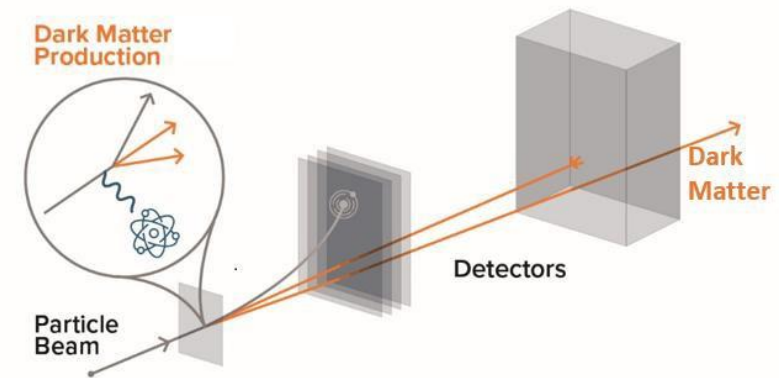

Extracted beams and/or colliders

Beam dump and fixed target experiments are essential tools to comprehensively probe feebly interacting particle and light new physics, complementing collider experiments

Complementarity: extracted beams have unique sensitivity to a large fraction of the parameter space of many models, especially for very small couplings at low masses, ideally complementing the reach of collider experiments.

Versatility: A wide variety of beams and techniques can be used to probe various types of couplings and final states. For example, proton beams produce many different initial states, and muon beams offer a unique window into the 2nd generation

Synergy: Many dark sector searches can be done with existing facilities and/or experiments, or would only require small modifications, thus reducing the resources required

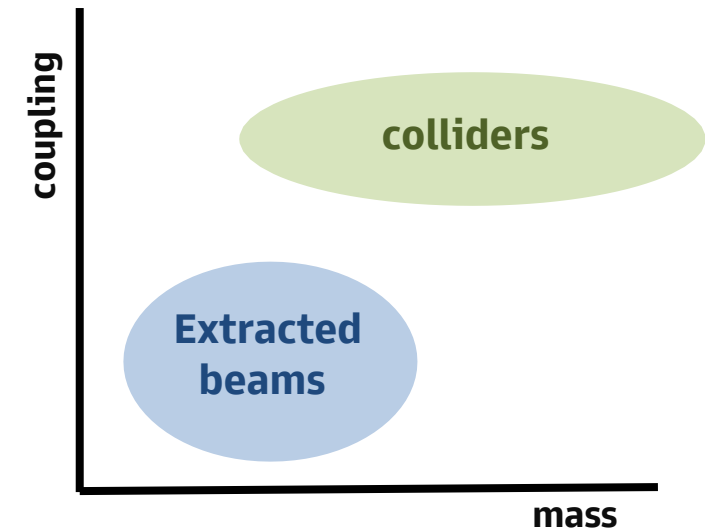

Dark sector taxonomy

Theory

mediator portal

Vector – $\varepsilon B^{\mu\nu} A'_{\mu\nu}$

Scalar – $H^2 (\mu S + \lambda S^2)$

Neutrino – $y\text{HLN}$

Axion – $g_{a\gamma} F^{\mu\nu} F_{\mu\nu} a$

Facilities / production

type of experiment

Electron/positron fixed target

Electron/positron beam dump

Proton beam dump (dedicated)

Neutrino experiments

Meson factories

(K, π, η, \dots) muon beams

Final state

experimental signature

(Semi-) visible decays

Missing mass

Missing momentum / energy

DM re-scattering

- I will use the dark photon as benchmark model, but considerations apply generically to other mediators, and review different experimental signature and a selection of experiments and facilities

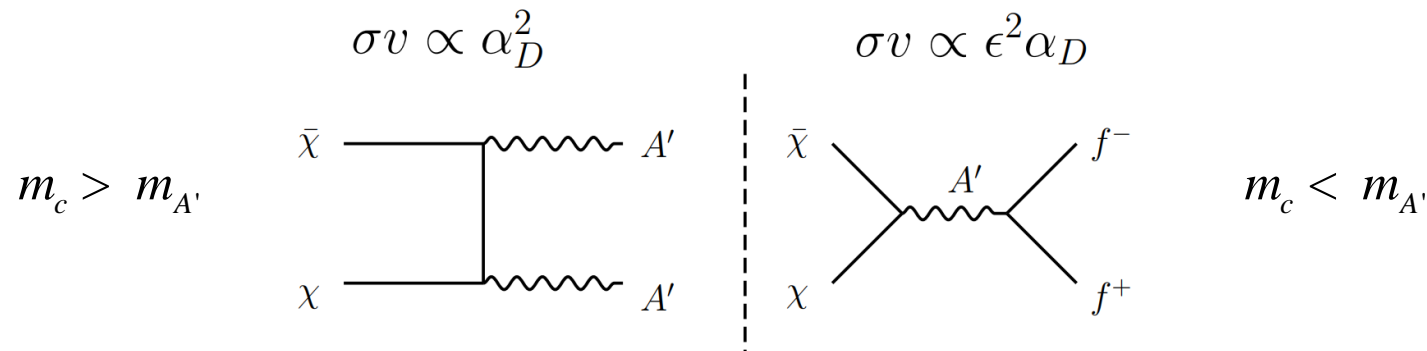

Dark photon searches in e^+e^-

- e^+e^- colliders provide stringent limits on dark mediators in the ~ 1 -10 GeV region
- *BABAR*, KLOE, Belle II
- *Example*
 - $e^+e^- \rightarrow \gamma A$, $A \rightarrow l^+l^-$ ($l = e, \mu$)
 - Visible and invisible modes
 - Dark Higgs
 - Leptophilic scalar
 - Dark $Z' \rightarrow \mu\mu$

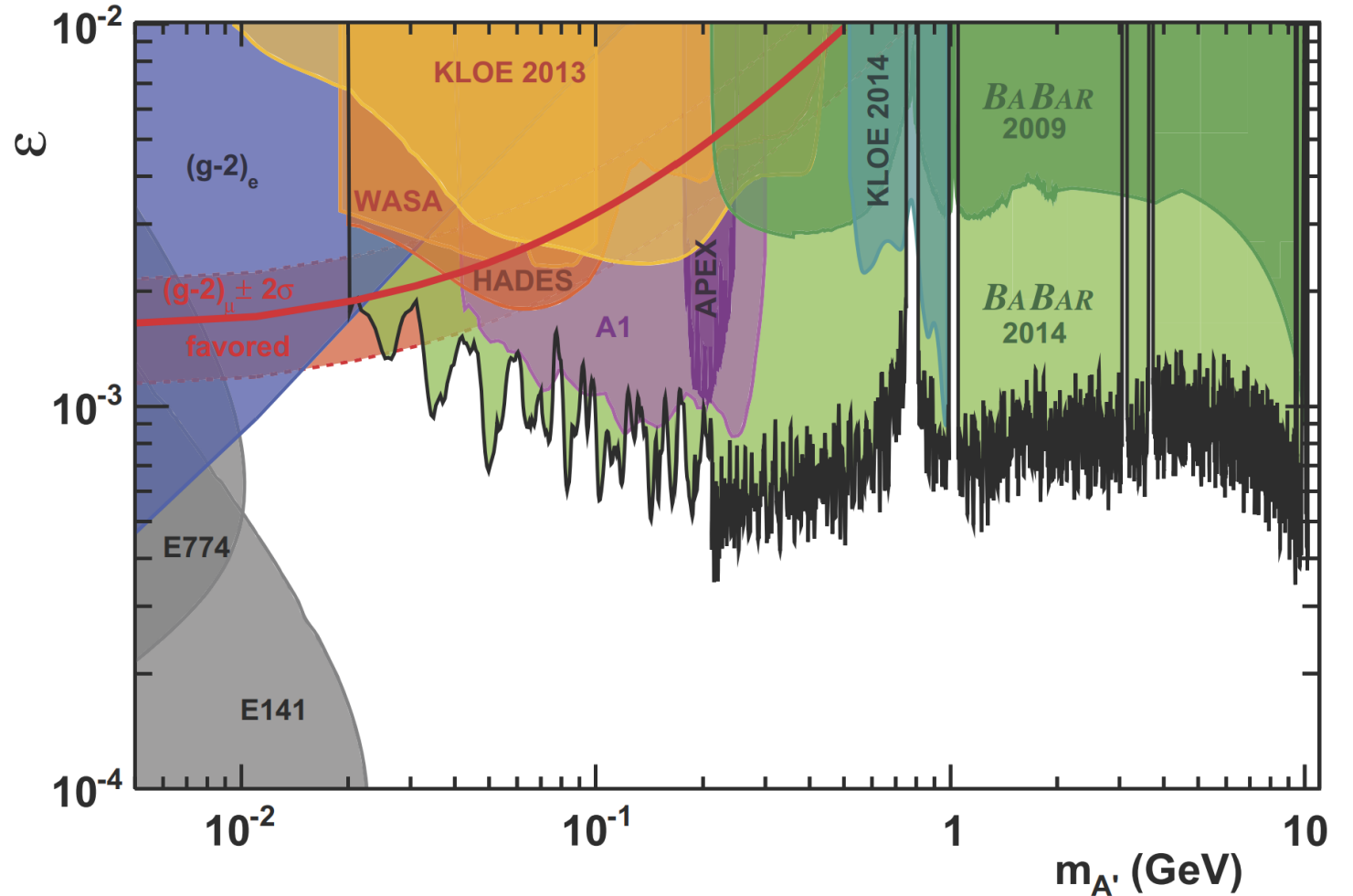

Visible / semi-visible decays

Visible



Main features – visible decays

- The dark photon is typically emitted in the forward direction (dark bremsstrahlung) and carries most of the beam energy
- The dark photon decays before or inside the detector
 - Large signal yield
- Beam dump constraints have a typical “triangular” shape

Main features – semi-visible decays

- More complex decay chains, multiple lifetimes and mass scales
- Example include inelastic DM, SIMP, dark showers,....

Semi-visible

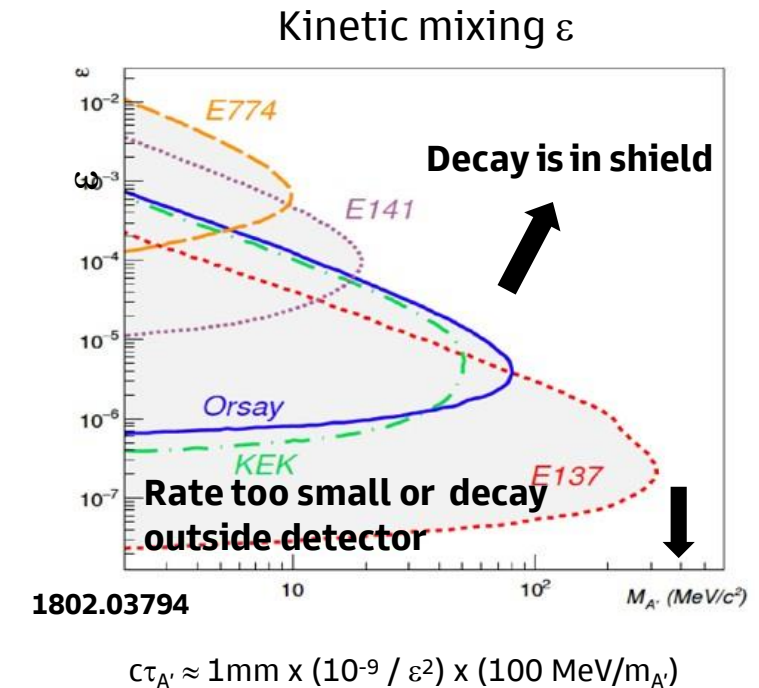
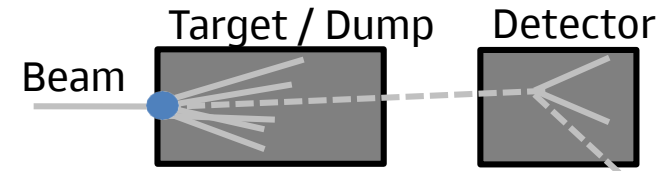

After 40 years SLAC E137 still provides best limits for many DM models

Missing mass

Fixed target

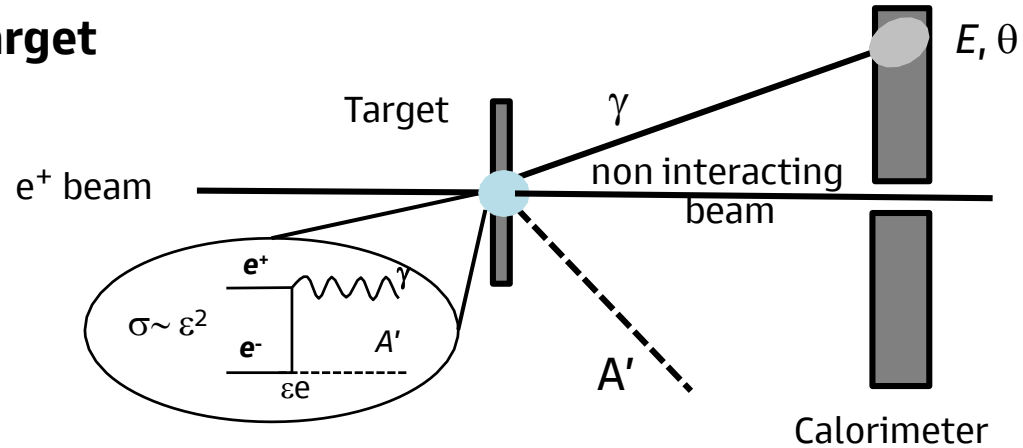

Decays

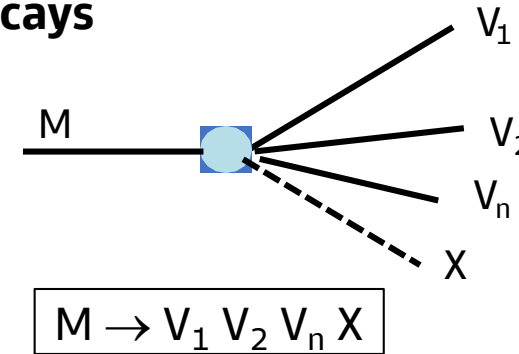

Main features

- Independent of mediator decay / dark sector structure \rightarrow large signal yield
- Typically bump hunt over large background, similar to collider searches
- Not many facilities with positron / meson / ... beams, and luminosity might be limited
- Limited $m_{A'}$ range can be probed, e.g., 5 GeV positron beam $\rightarrow m_{A'} < 71$ MeV on fixed target

Missing energy / momentum

Missing energy

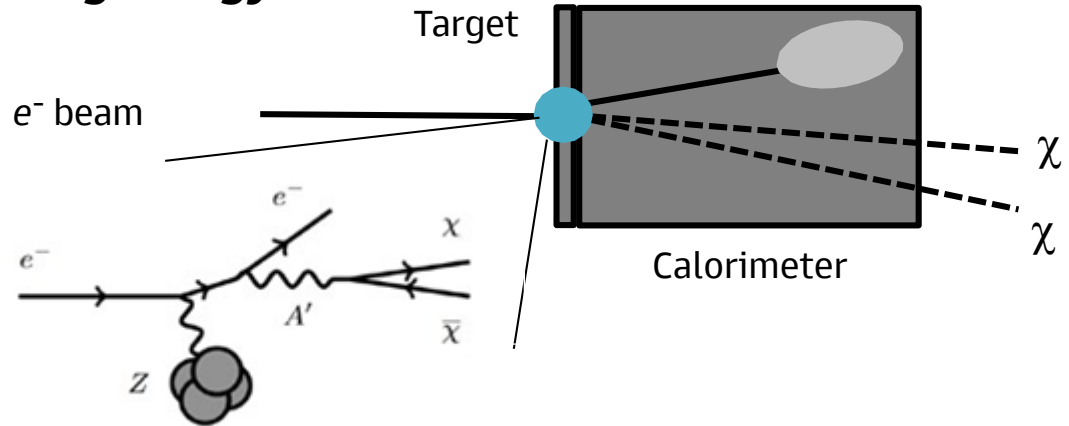

Missing momentum

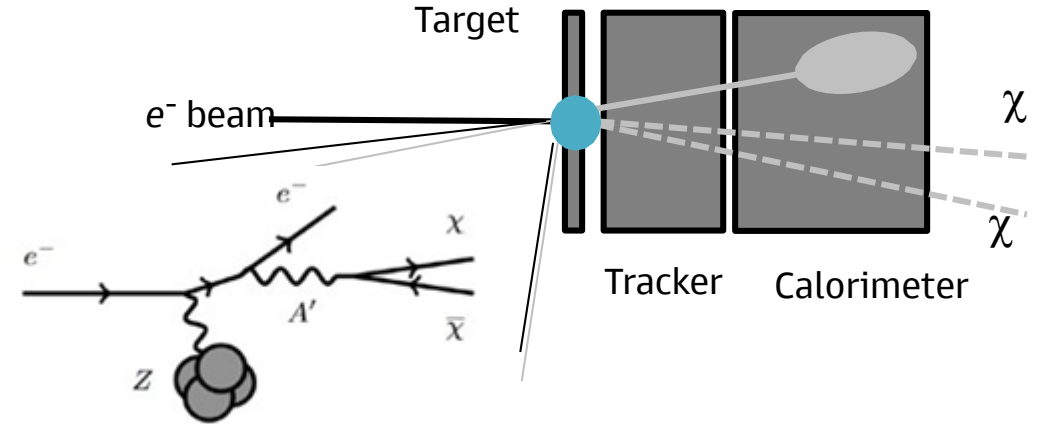

Main features

- Measure one electron at a time to uniquely associate incoming and outgoing particles
- Search for events with large Δp or ΔE and nothing else in the detector
- Large signal yield, maximizing sensitivity for a given number of electrons

Missing energy vs missing momentum

- Missing energy has higher signal yield / electrons on target (EOT); background become challenging beyond 10^{14} EOT
- Missing momentum provides an additional p_T discriminator: the p_T spectrum is sensitive to $m_{A'}/m_{\chi}$. With e^- , γ identification, this technique is essentially background-free up to 10^{16} EOT

Missing Momentum: Physics Design Drivers

Gaussian energy fluctuations

Rare reactions → products escape ECal and/or anomalous energy deposition

Irreducible prompt \cancel{E}

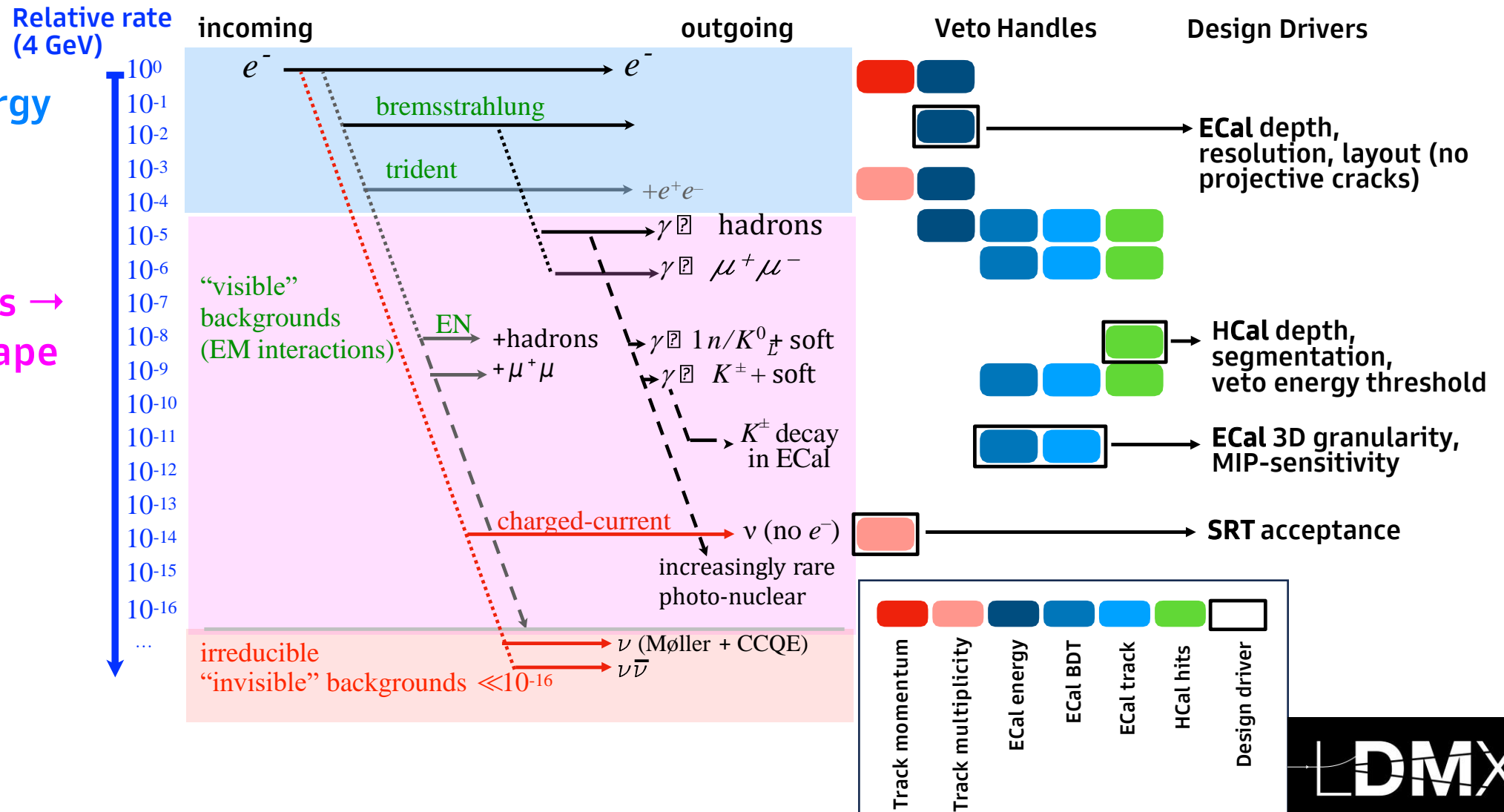

Dark matter re-scattering

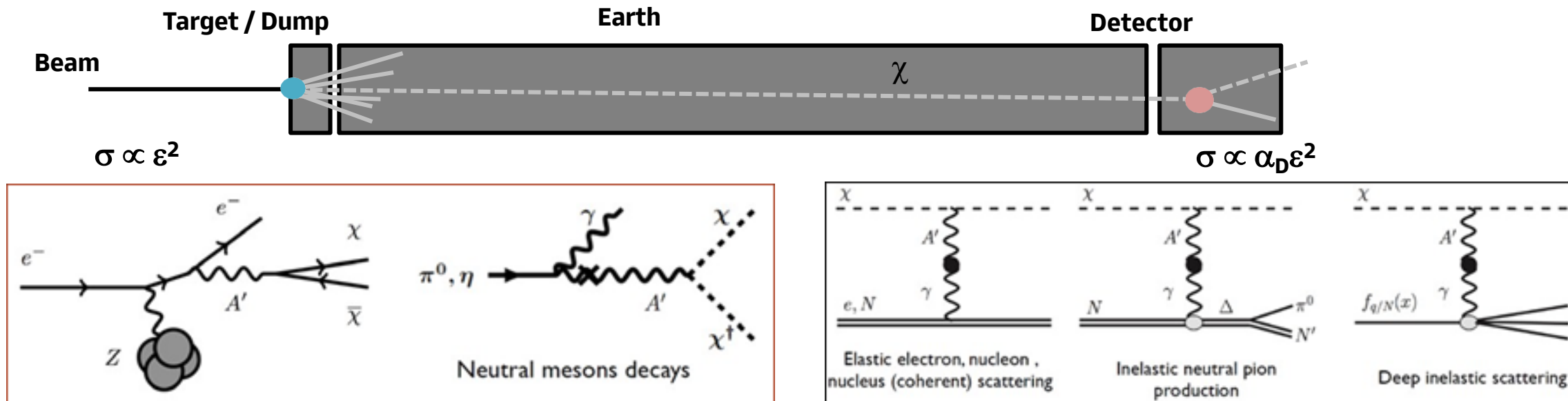

Main features

- Signal yield is low ($\sigma \sim \epsilon^4$); need a very large flux to compensate
- Sensitive to dark sector coupling constant, $\alpha_D = g_D / 4\pi$
- There is a non-negligible neutrino background that is mitigated using timing and a thick target (beam dump mode)



MiniBooNE 1807.06137

Mediator Decays to the SM

Searches are bump hunts for $m(l^+l^-)$ resonances



A' becomes long-lived at small couplings

$$\gamma_{CT} \propto \frac{1}{\epsilon^2 m_{A'}^2}$$

This leads to constraints from beam dump experiments

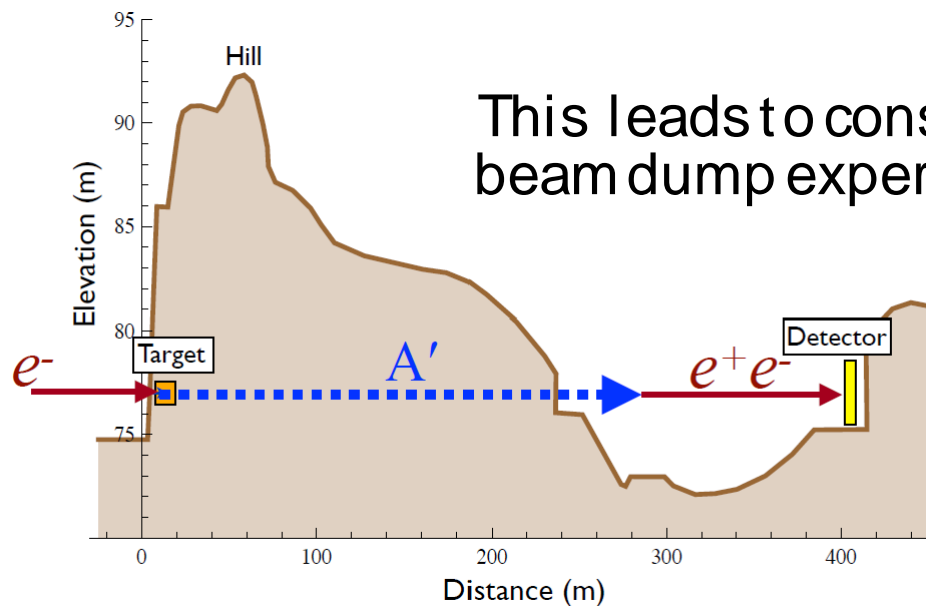

Current A' Constraints:

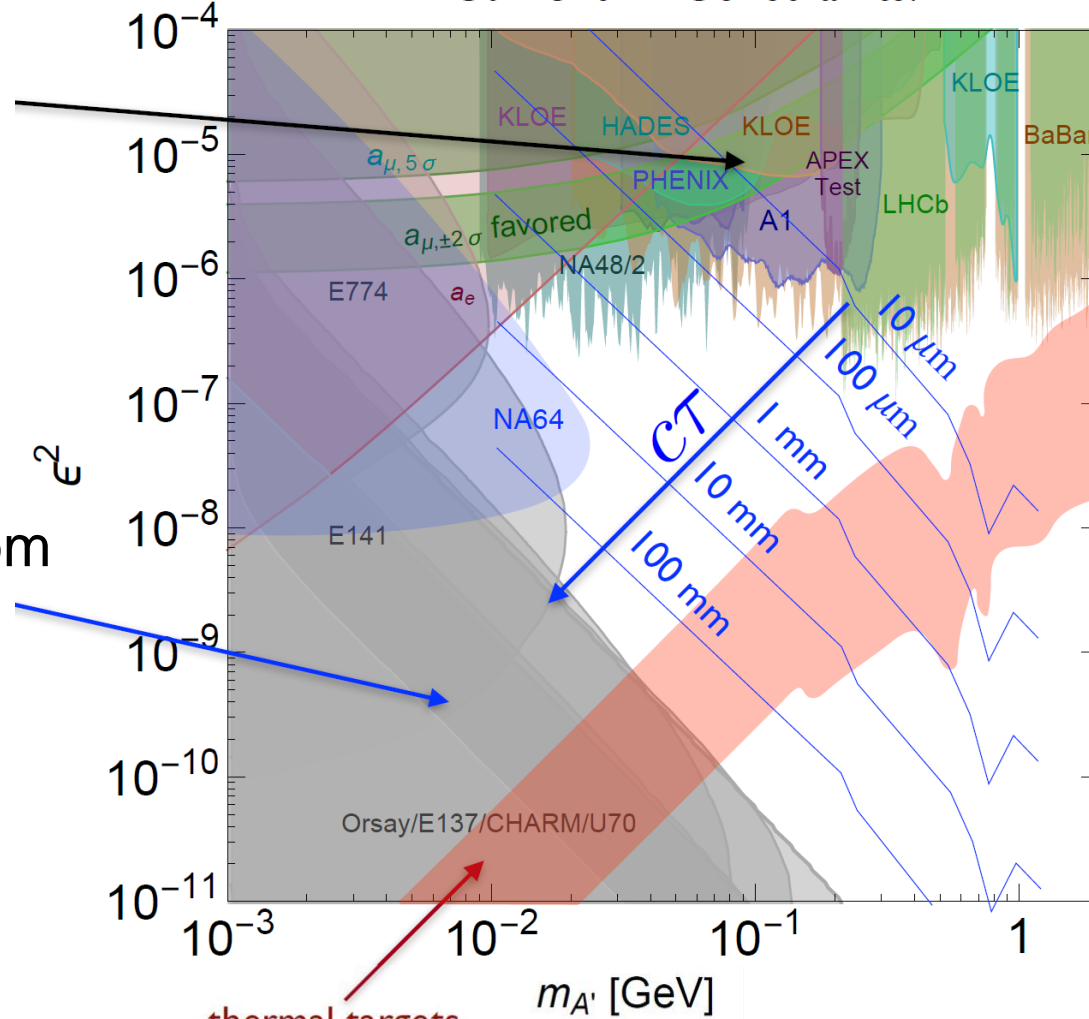

$\alpha_D = 0.5, M_{A'}/M_X = 1.5$

Landscape of extracted beam experiments

A selection of current and future experiments

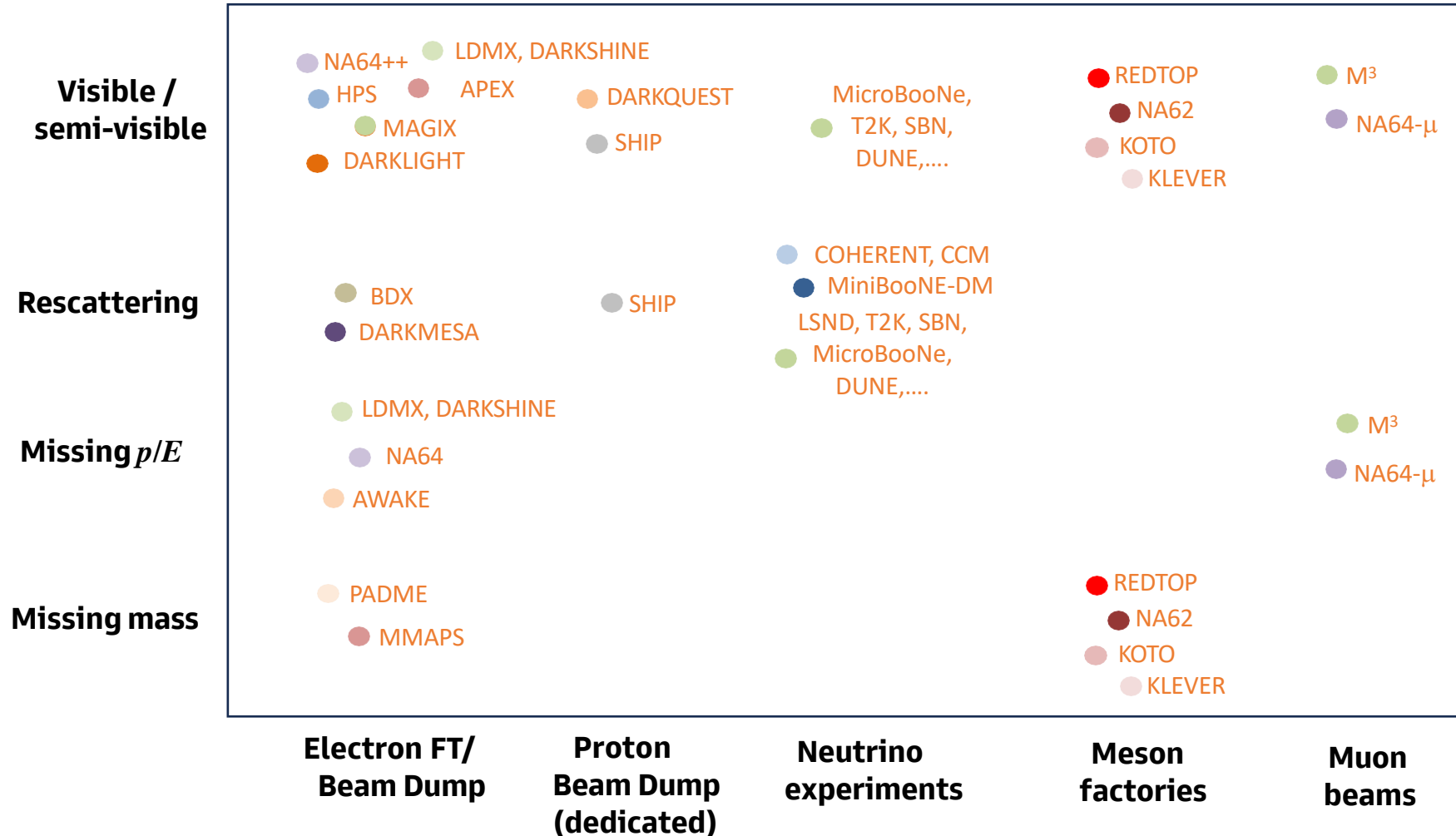

Electron beams – visible decays (fixed target)

APEX @ JLab CEBAF

- Resonance search using dual arm High-Resolution Spectrometers (Hall A)
- Dark photon bremsstrahlung production from multi- GeV e^- beam on high Z target
- Search for $A' \rightarrow e^+e^-$ resonance
- Proposed in 2010, 15 day run in 2019 at 2.2 GeV

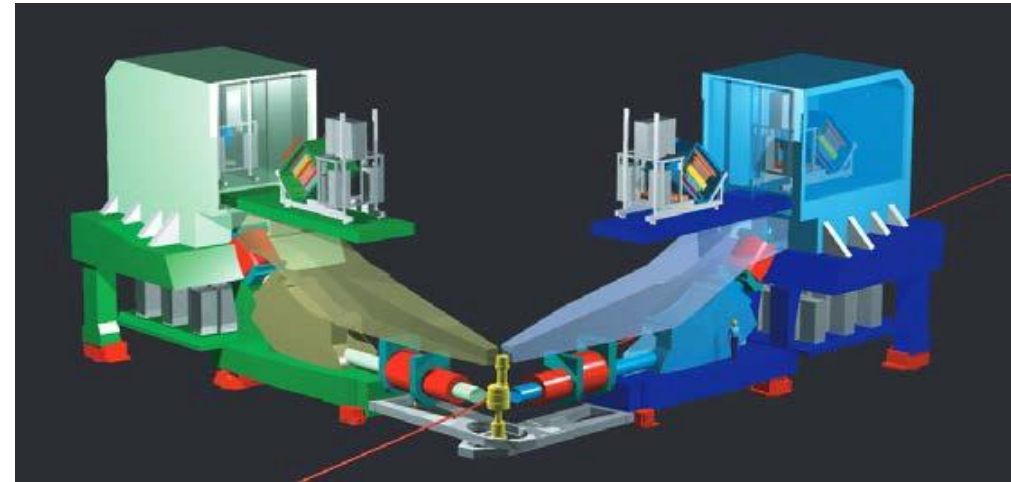

HPS @ JLab CEBAF

- Compact e^+e^- spectrometer (Hall B)
- Low-mass, high-rate silicon vertex tracker and ECal trigger to suppress scattered single electrons
- Prompt and displaced dark photon searches + SIMP
- First physics run in 2019 (2 weeks at 4.55 GeV) plus 4 weeks in 2021
- Future run plan under review at JLab

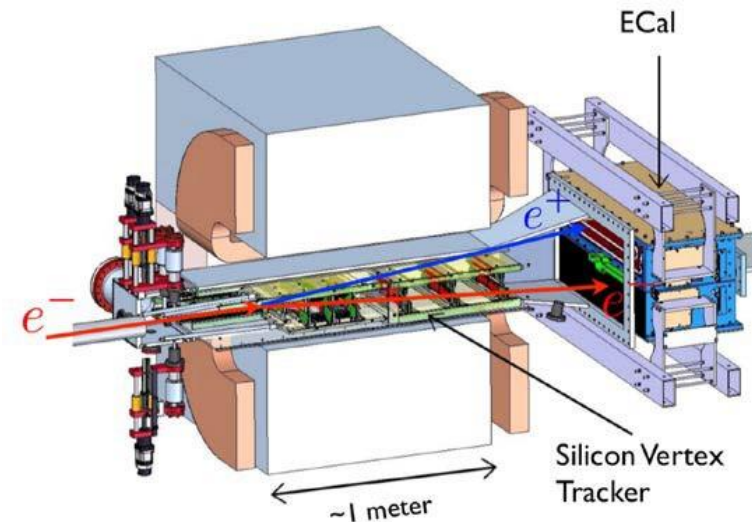

Electron beams – visible decays (fixed target)

DARKLIGHT @ JLAB LERF / CEBAF

- Originally proposed at LERF to search for dark photon bremsstrahlung with full final state reconstruction $ep \rightarrow epA'(\rightarrow ee)$
- Very challenging concept!
- New proposal: a dual spectrometer operating at the CEBAF injector - 45 MeV beam energy
- Under review by JLab PAC

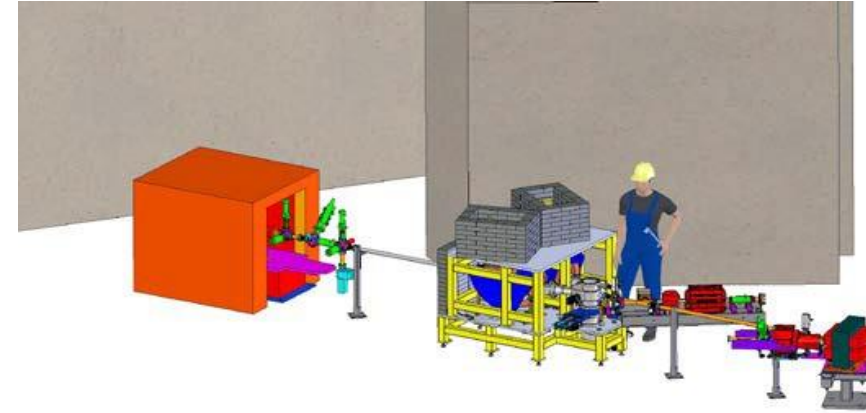

www.jlab.org/exp_prog/proposals/18/PR12-18-006.pdf

MAGIX @ MESA

- Dual arm magnetic spectrometer with windowless gas stream target
- Mainz MESA energy recovery linac, 105 MeV e^- beam
- Search for di-electron resonance and three-body missing-mass (with recoil nucleus reconstruction)

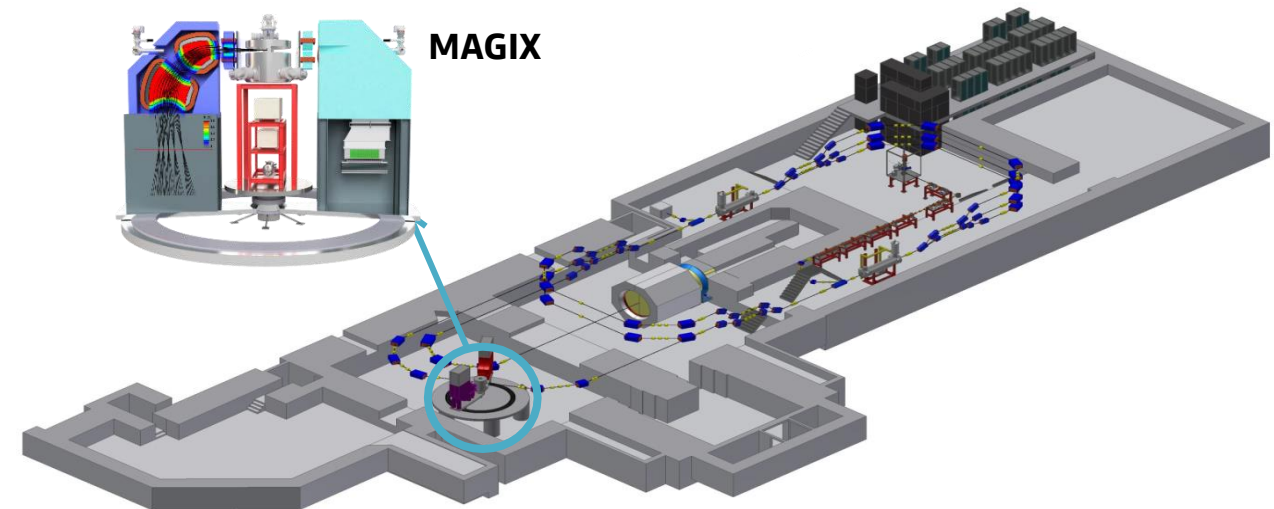

Electron beams – visible decays

Kinetic mixing constraints – visible decays

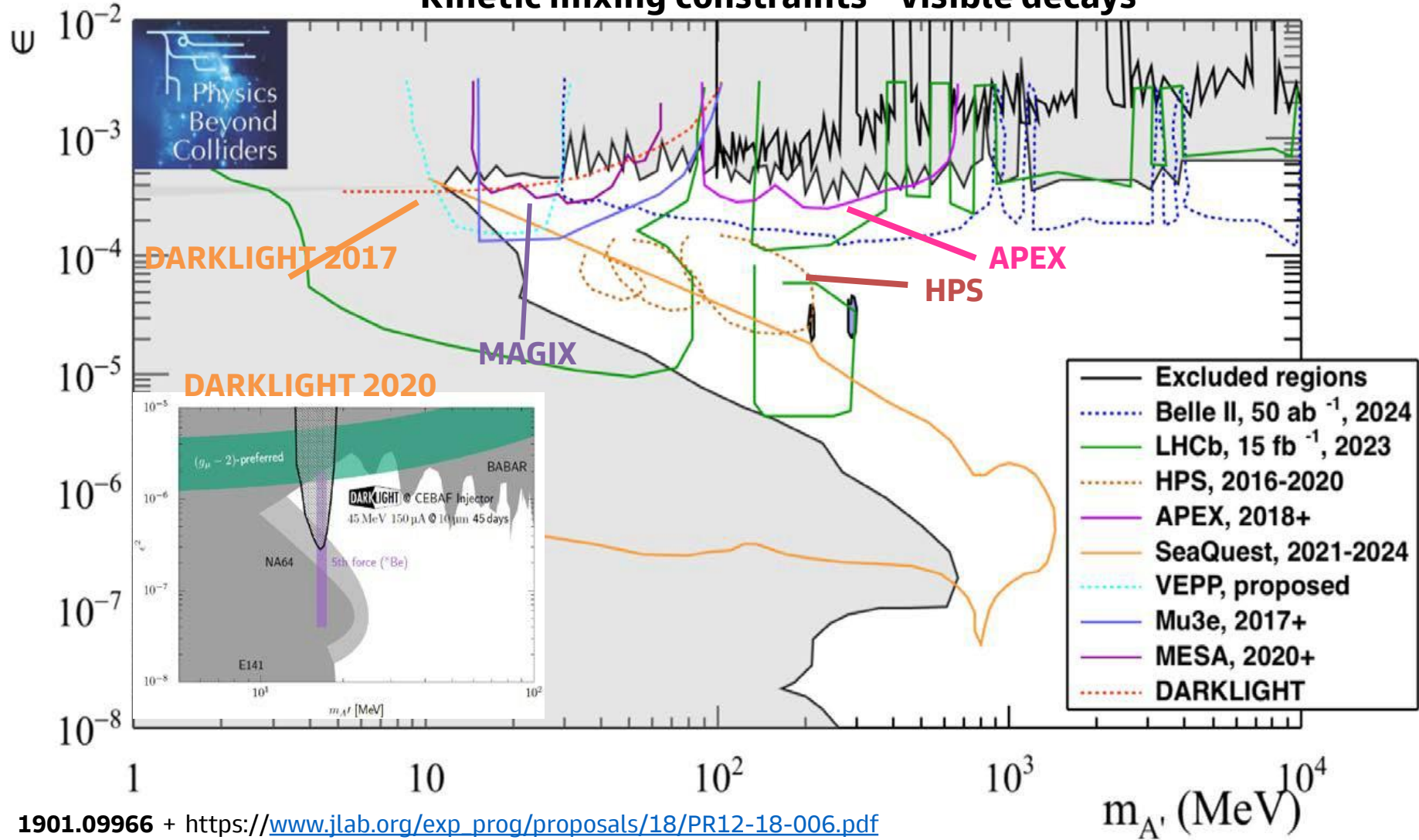

1901.09966 + https://www.jlab.org/exp_prog/proposals/18/PR12-18-006.pdf

Electron beams – DM rescattering (beam dump)

BDX @ JLAB CEBAF

- Search for DM scattering producing a visible recoil with 11 GeV beam
- Homogeneous CsI calorimeter and active veto
- Sensitivity limited by irreducible neutrino bkg
- Need new underground experimental hall
- Collected 2×10^{21} EOT with BDX-Mini prototype

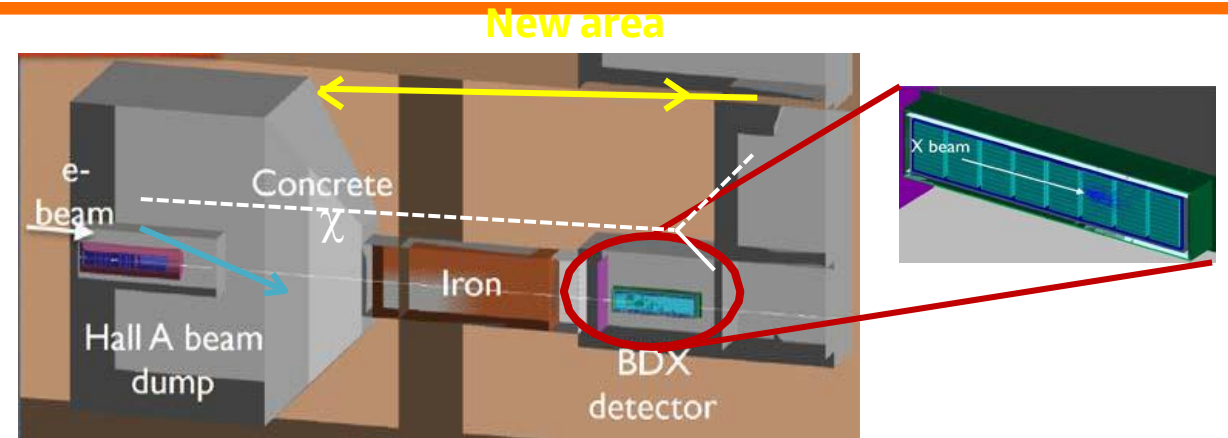

DARKMESA @ MESA

- Search for DM scattering producing a visible recoil with 155 MeV electron beam
- PbF_2 and Pb-glass scintillator
- Very low background, since below $ep \rightarrow en\pi^+$ production threshold
- Envision staged development in three phases up to $O(10) \text{ m}^3$

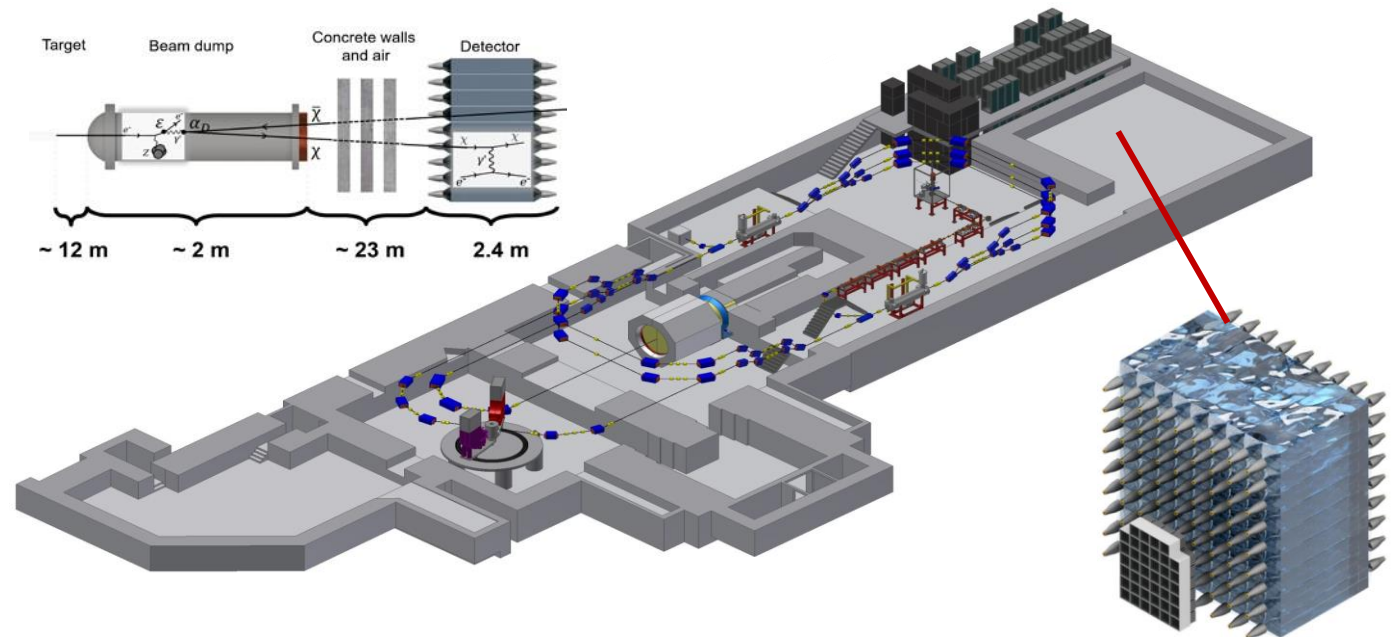

Electron beams – missing energy (beam dump)

NA64 @ CERN

Missing energy experiment at the 100 GeV secondary electron beam line at SPS

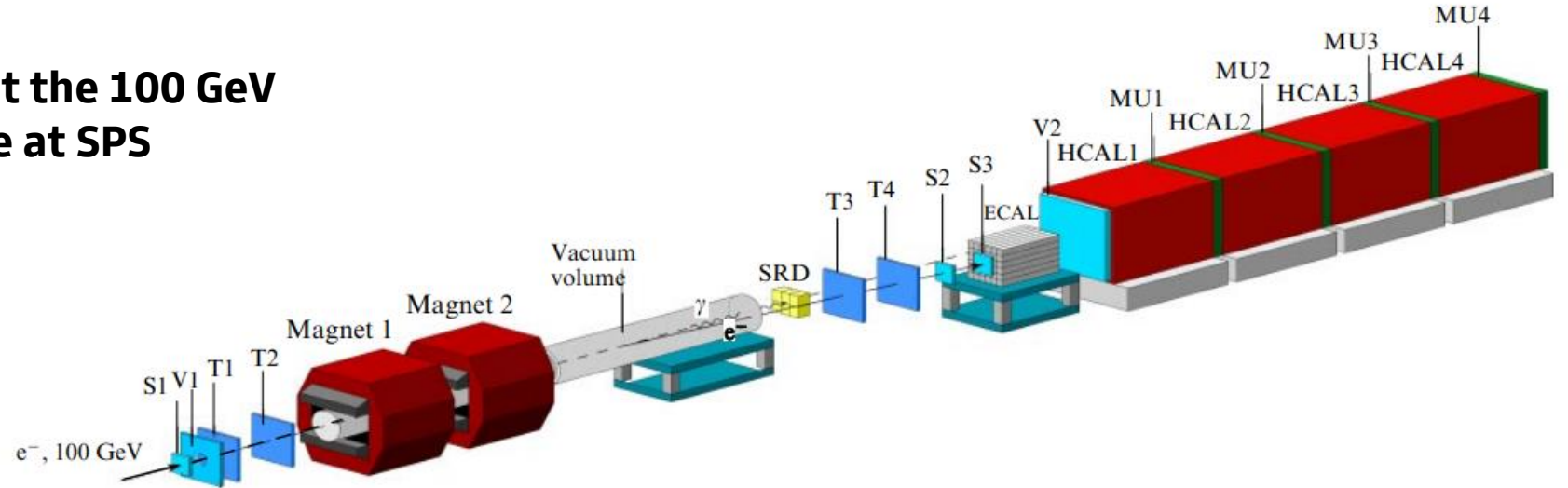

Experimental concept

- Tracking system to measure energy of incoming e^-
- ECAL as active target to produce A'
- Measure outgoing energy with ECAL and HCAL
- Search for large missing energy $E_{\text{ECAL}} + E_{\text{HCAL}}$ (it is difficult to lose 100 GeV!)

NA64++ : modification to study visible $A' \rightarrow e^+e^-$ decays

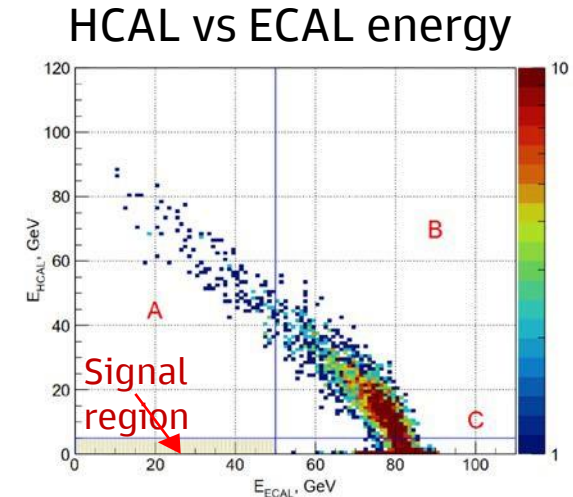

Electron beams – missing momentum (fixed target)

LDMX @ SLAC

- Missing momentum (and energy) experiment at LESA beamline - parasitic
- **Phase I with 8 GeV beam (4×10^{14} EOT) (originally 4 GeV)**
Phase II with 8 GeV beam extends to 10^{16} EOT
- Upstream and downstream tracking system measures the momentum of incoming and outgoing electron
- High granularity ECal and HCal to measure outgoing energy and provide an efficient veto
- Search for events with single recoiling electron and no additional activity
- The ultimate goal is to probe nearly the entire thermal DM parameter space in the MeV-GeV region

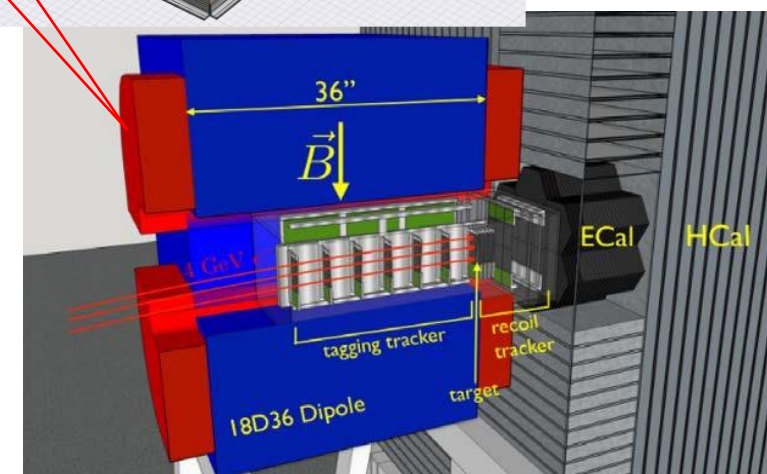
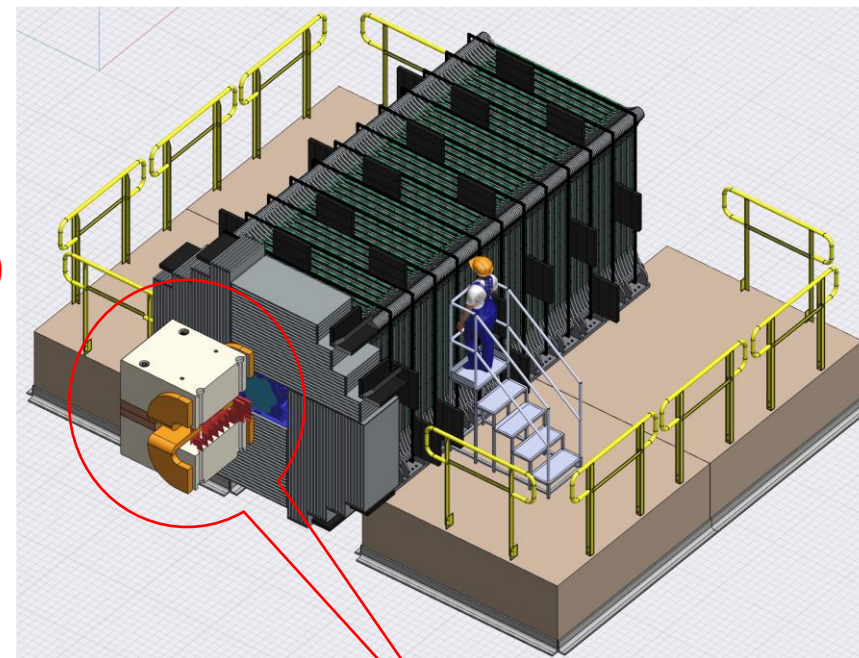

LDMX Experimental concept

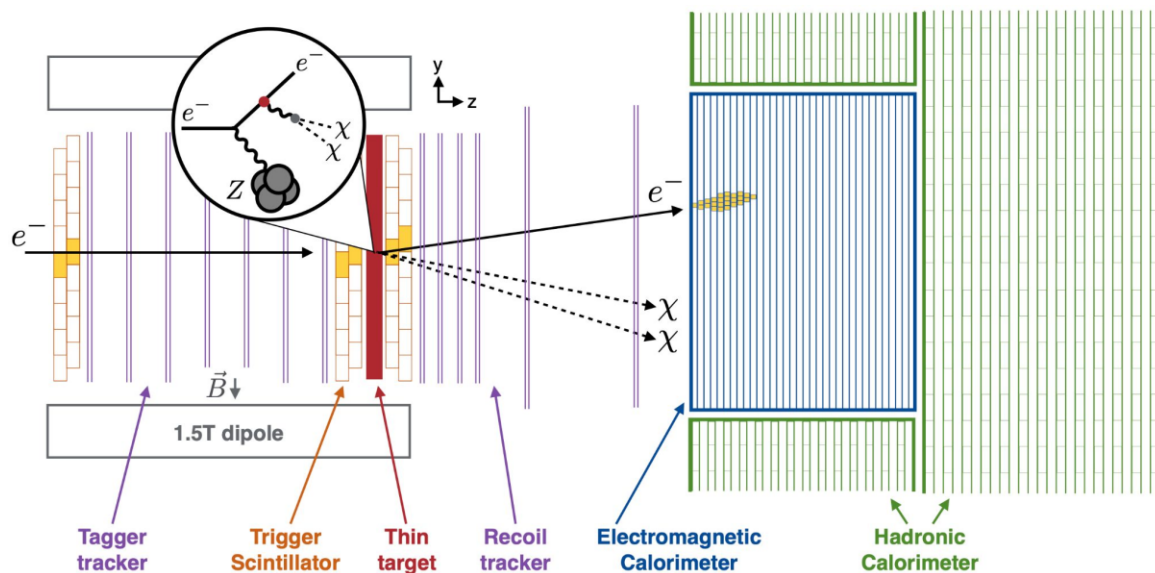

Beam which enables $O(10^{16})$ electrons to be individually identified & reconstructed

low-current, high repetition rate beam
($10^{16}/\text{year}$ is $\sim 1e^- / 3 \text{ ns}$)

S30XL+LESA using idle cycles of LCLS-II @ SLAC (4/8 GeV)

Detector technology with fast readout and high radiation tolerance

high momentum resolution, low mass tagger/recoil tracker
high energy resolution EM calorimeter (EMCal)
deep hadron calorimeter (HCal) with good efficiency for $O(1 \text{ GeV})$ neutrons

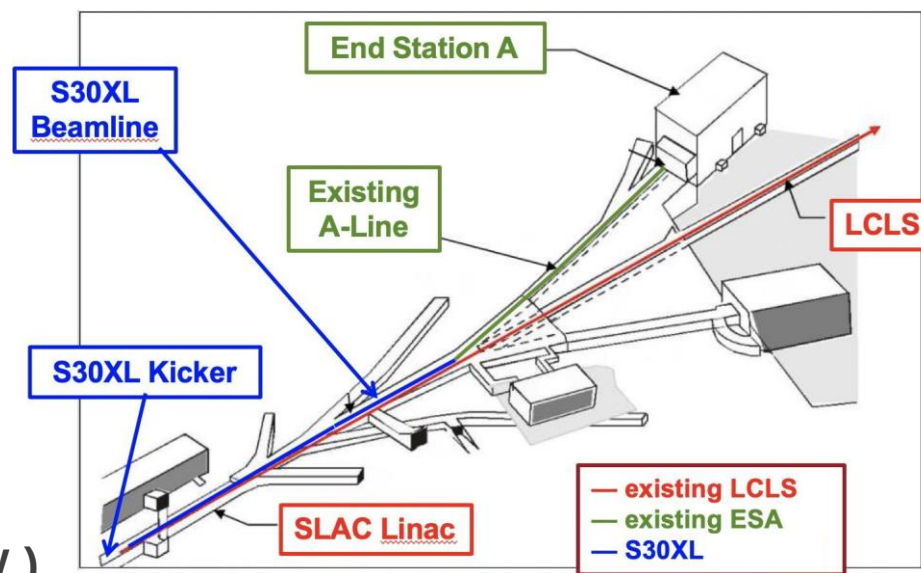

+ LESA

Tracker

Tracker based on successful HPS design

Tagger Tracker in 1.5T dipole field to reject off-momentum incoming particles

Recoil Tracker in fringe field to measure momentum of recoil electron (including p_T), reject tridents and other events with multiple charged particles emerging from the target

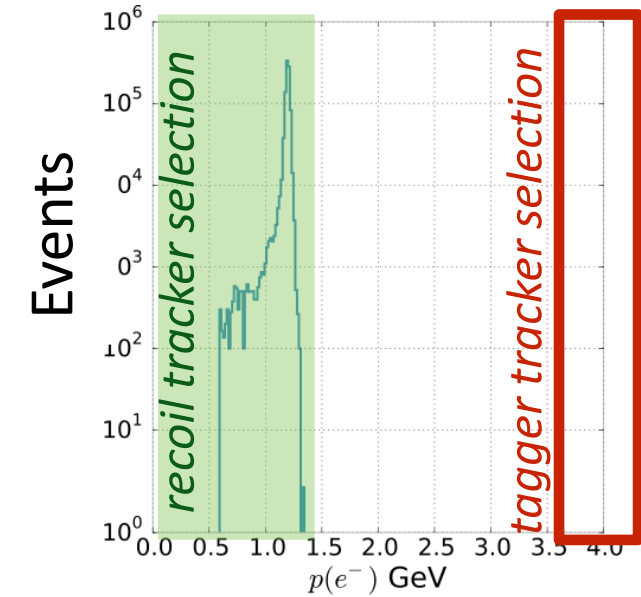
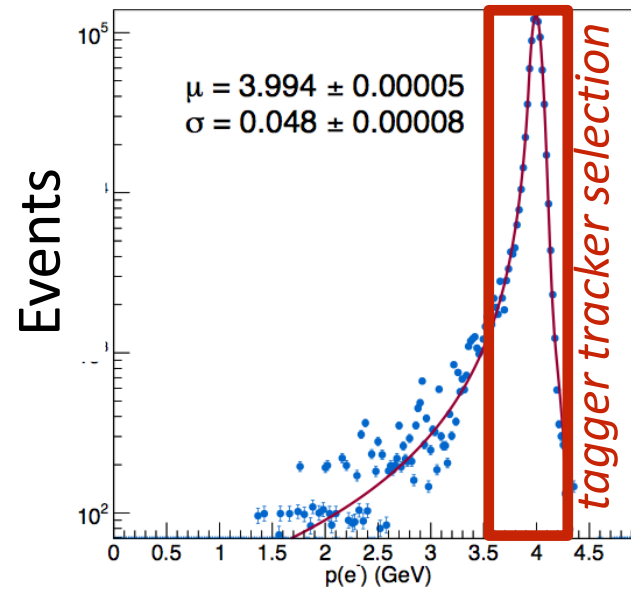
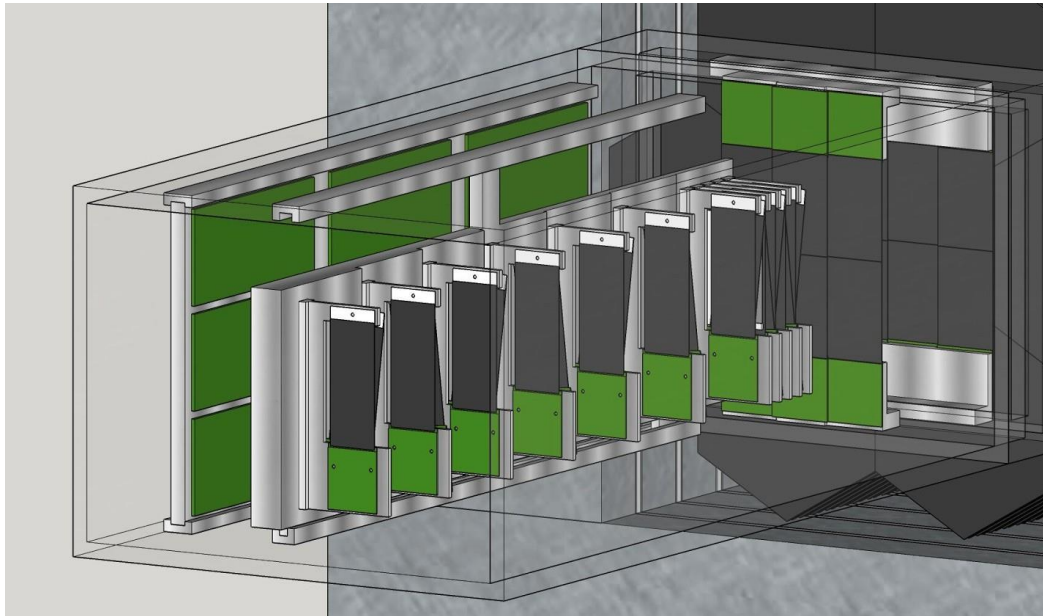
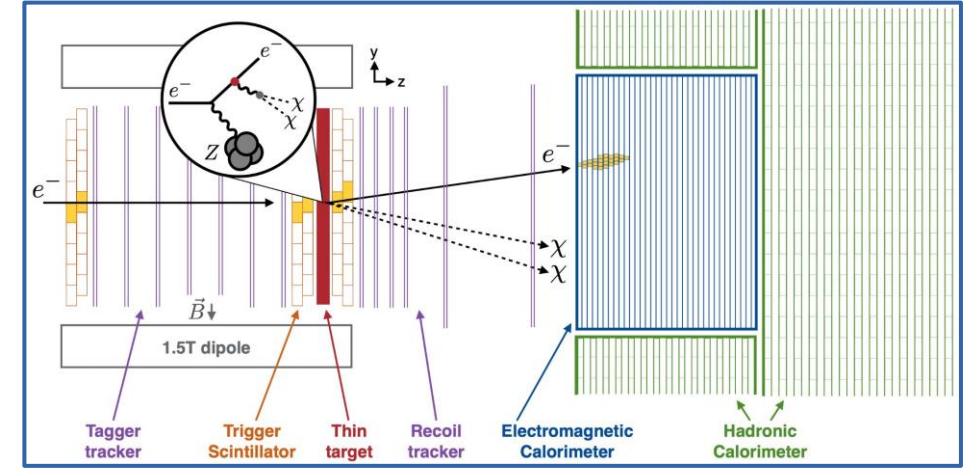

Electromagnetic Calorimeter

Electromagnetic calorimeter based on CMS HL-LHC Endcap Calorimeter (HGCal)
 40 X_0 W-Si imaging calorimeter with fast shaping and readout, radiation tolerant
 MIP sensitivity (S/N=10-15), precision shower timing (50 ps)

High granularity (100k channels): measure transverse & longitudinal shower shapes to reject PN events using ML algorithms and handle multiple incoming electrons in a single integration period

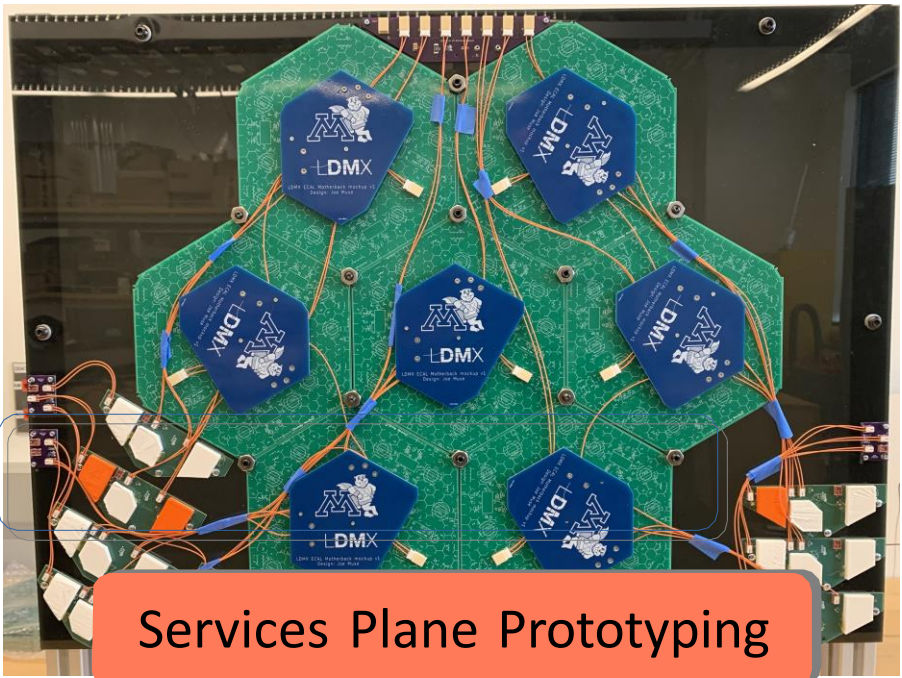
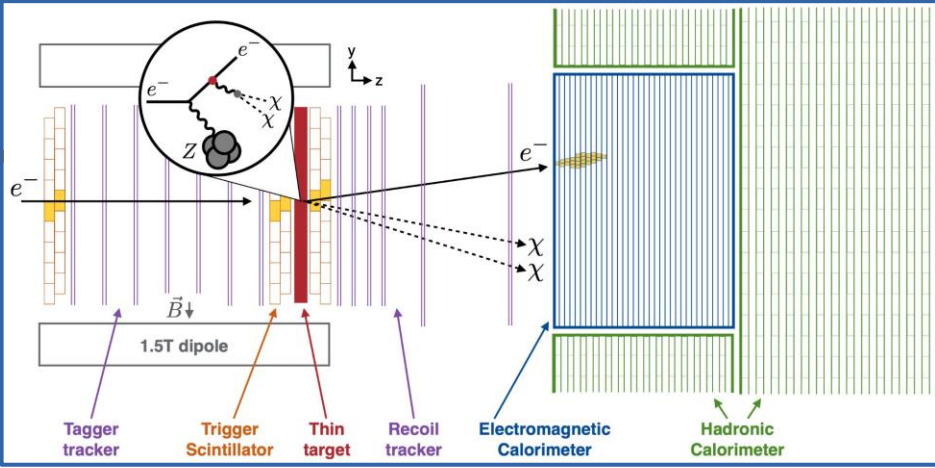

Services Plane Prototyping

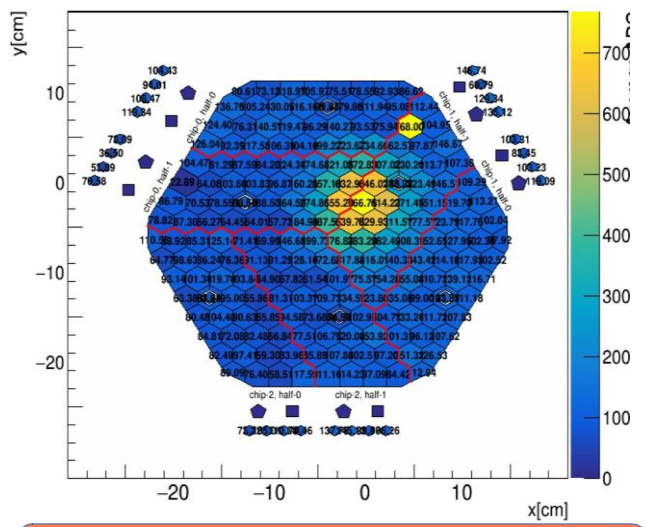

CMS Electron Testbeam

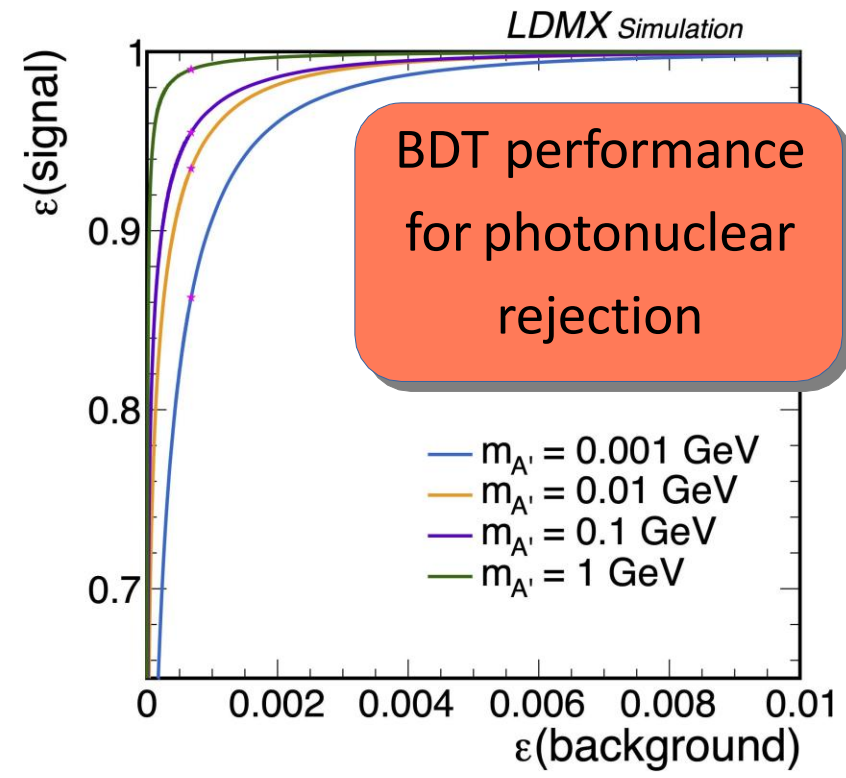

Hadron Calorimeter

Steel/scintillator with WLS fiber/SiPM readout derived from Mu2e

Highly efficient veto (10^{-6}) for photonuclear processes that produce neutral hadrons

Side HCal rejects wide angle bremsstrahlung and $\gamma \rightarrow \mu^+ \mu^-$

Enables synergistic measurements in visible signatures and nuclear processes relevant for DUNE program

Performance demonstrated in CERN T9 test beam

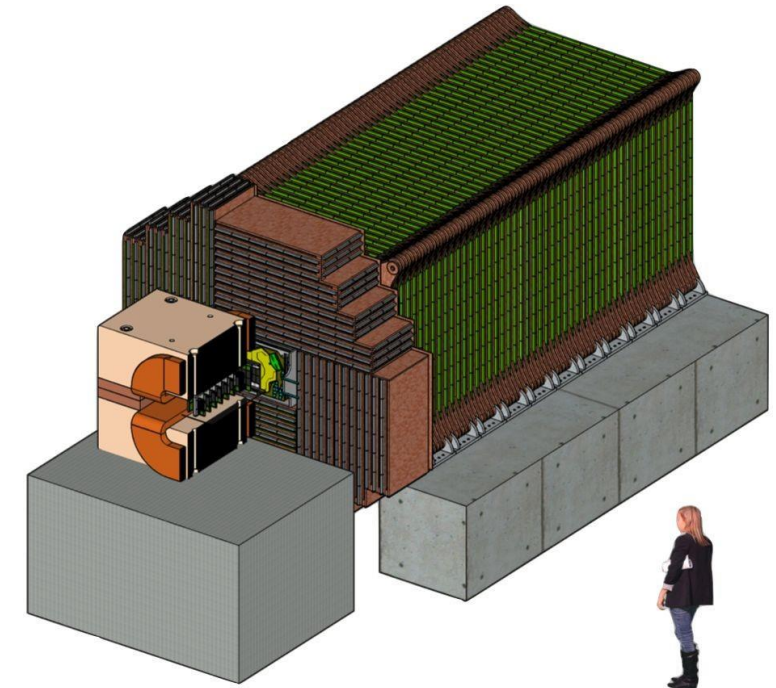
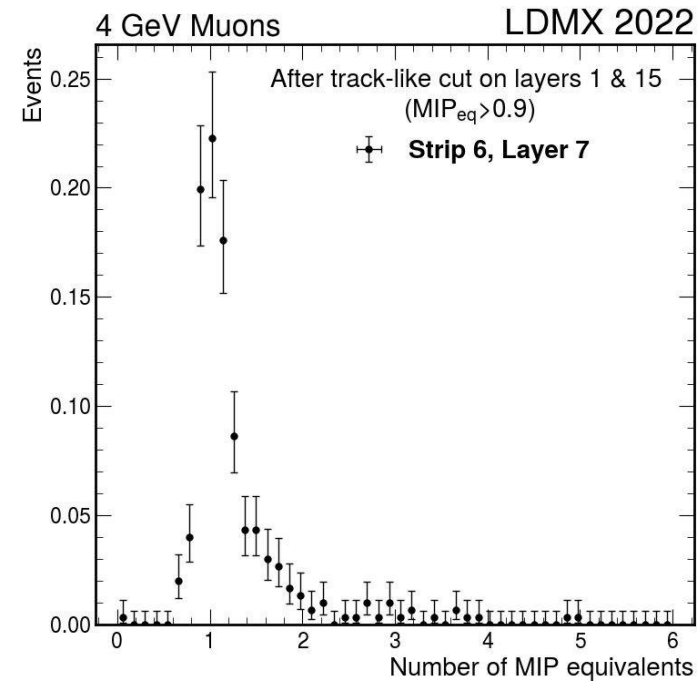
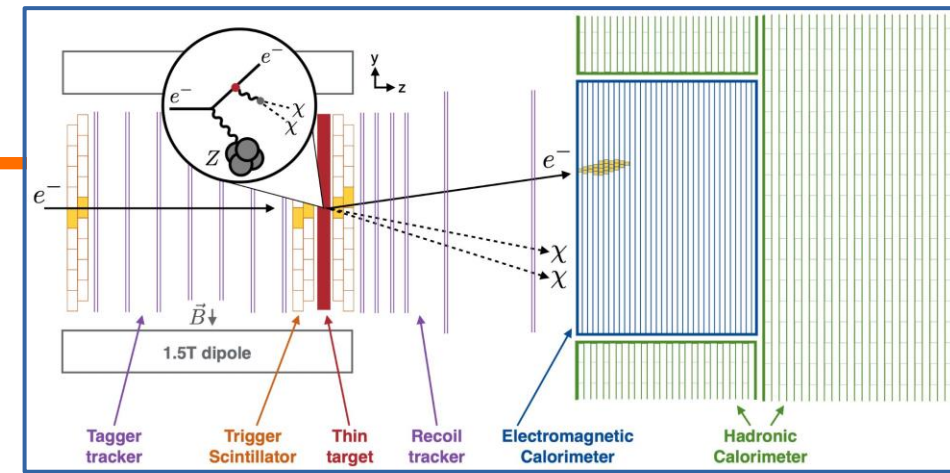

Missing energy trigger

Trigger based on missing energy as measured in ECal

ECal triggering with a missing energy of 2.5 GeV reduces rate from 37 MHz to 0(1 kHz)

Trigger scintillator hodoscope determines number of incoming electrons in an event, which is needed to determine appropriate total energy expectation for a given bunch

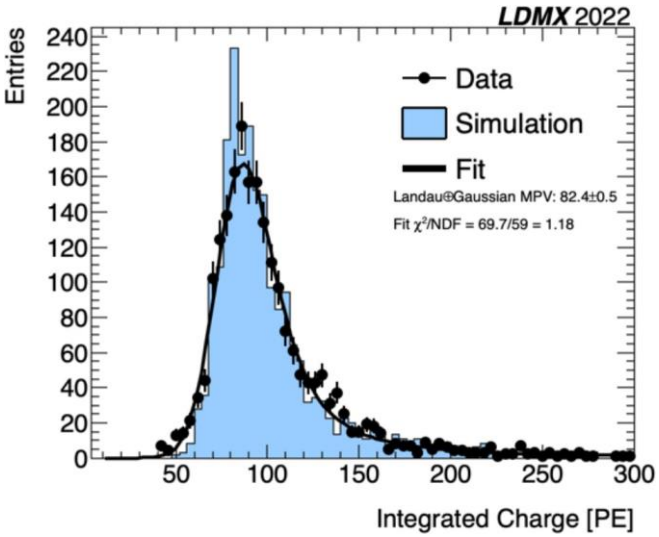
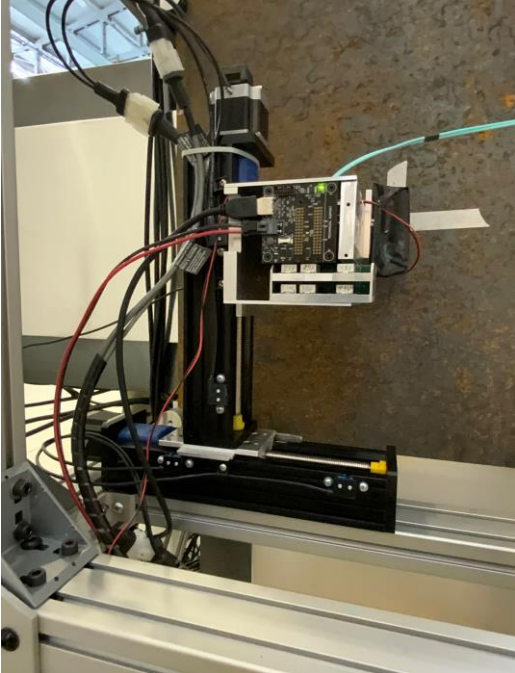
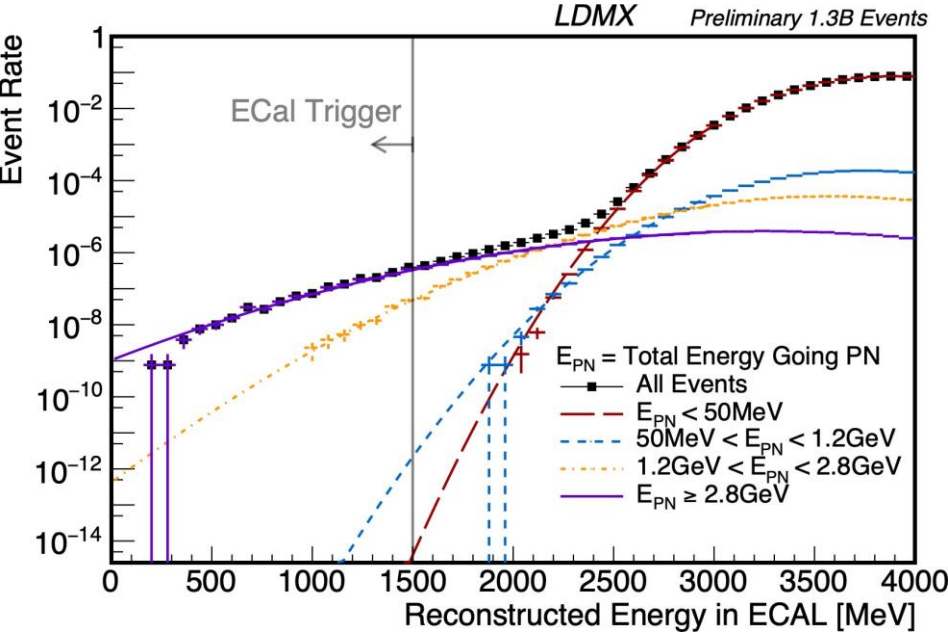
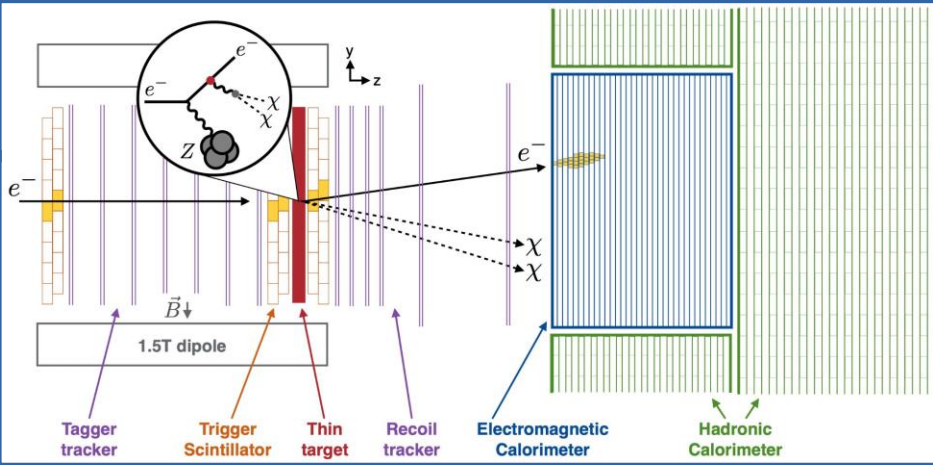

LDMX Sensitivity (4 GeV)

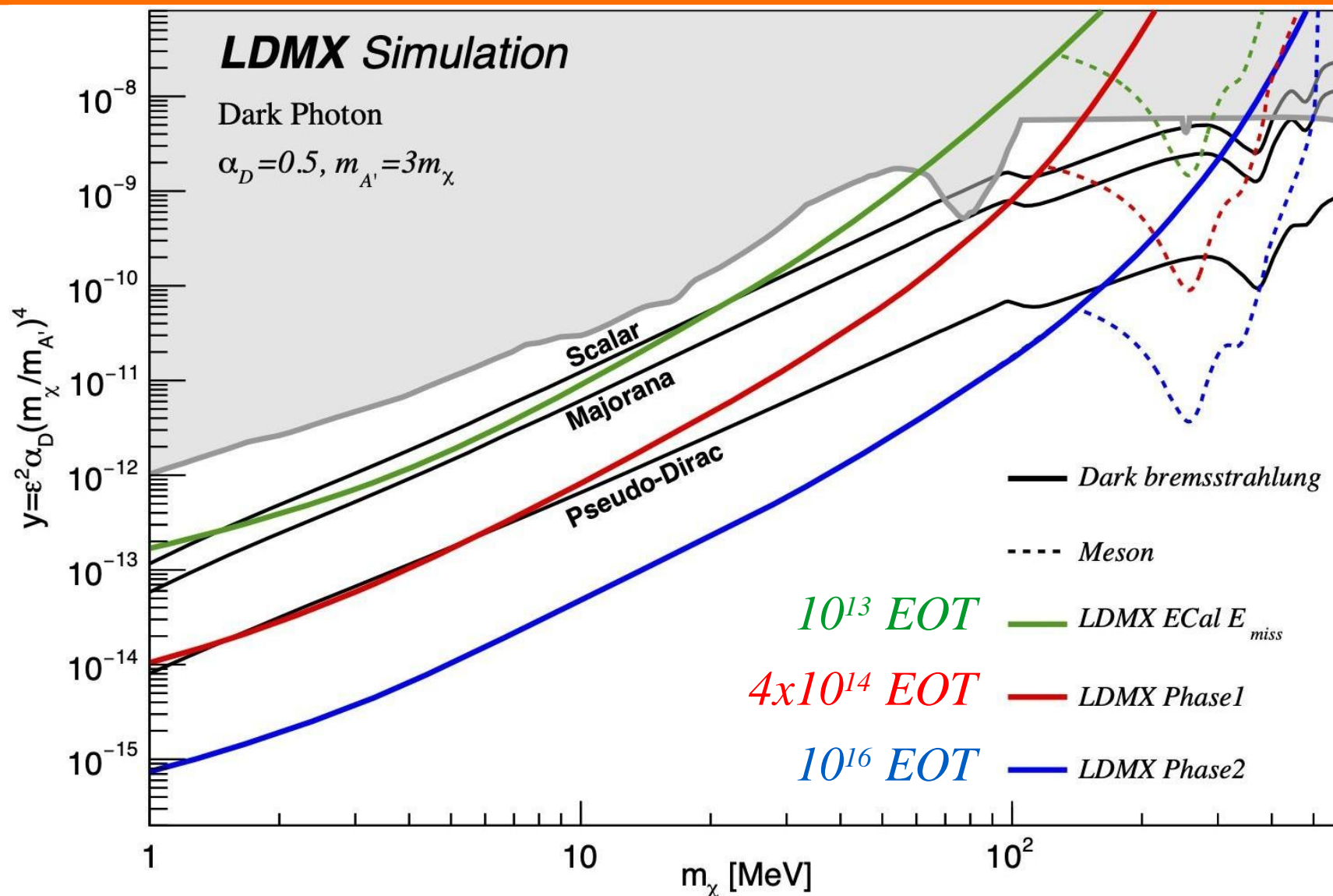

LDMX with an 8 GeV Beam

The LCLS-II upgrade schedule and the uncertain date of DOE approval of LDMX make it likely that most or all of LDMX data will be at 8 GeV rather than 4 GeV

The increase in beam energy reduces the predicted relative rate of many photonuclear backgrounds, particularly for challenging cases such as a single neutron

8 GeV slightly improves the high mass reach somewhat while retaining performance at low mass

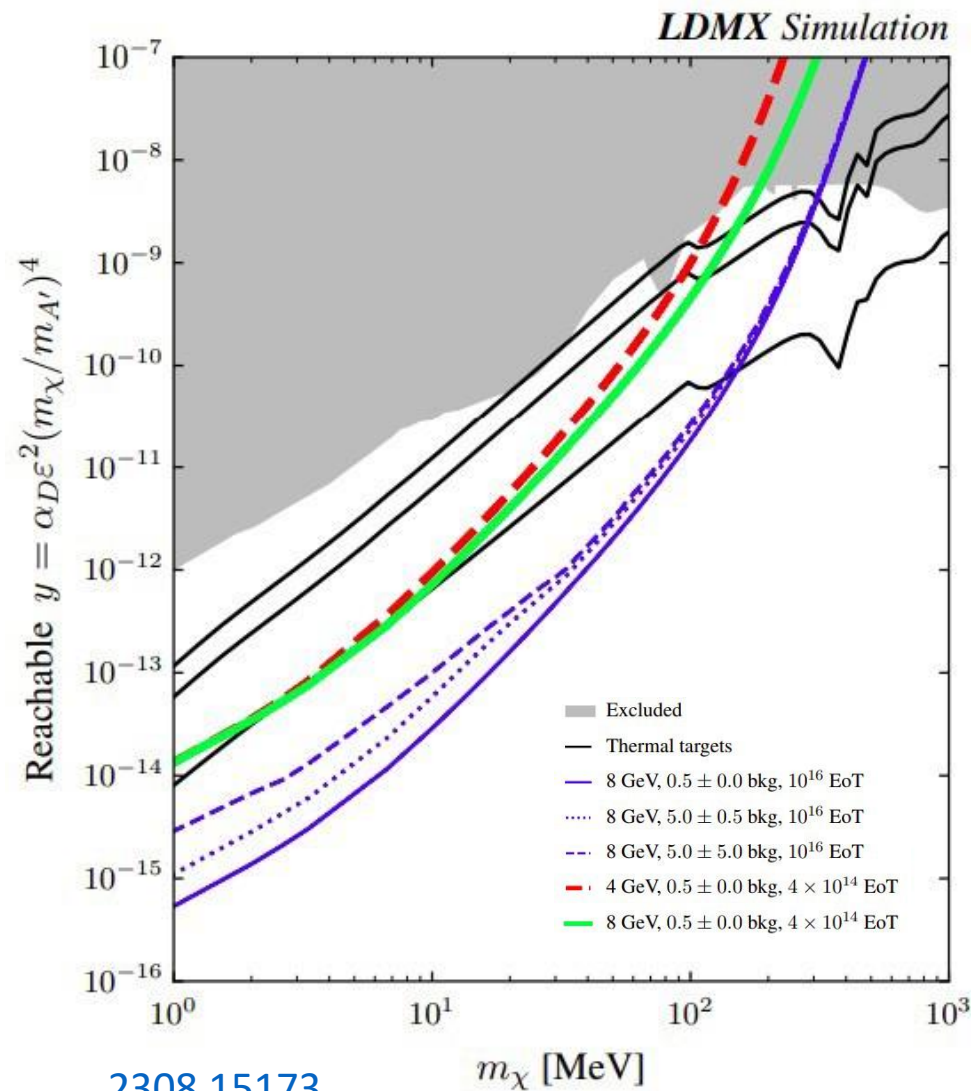
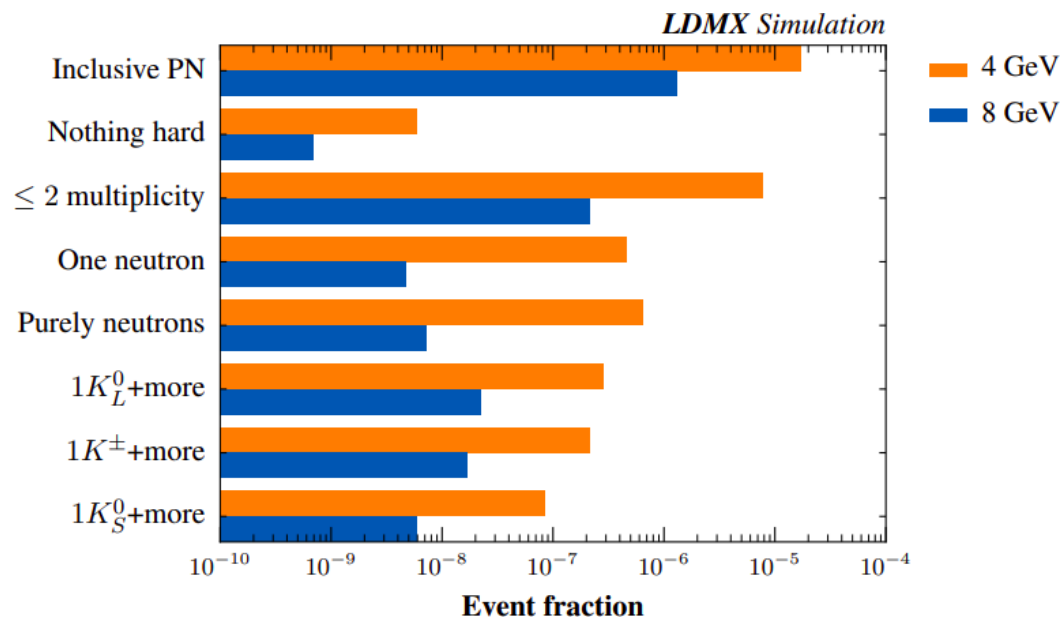

Beyond dark photons

LDMX @ SLAC

Other BSM scenarios

- Other mediators (B-L, leptophilic,...)
- Asymmetric DM, ELDER, freeze-in DM,...
- Inelastic DM, both visible and invisible final states
- Milli-charged fermions (can probe EDGES region)
- Axion-like particles
- Strongly interacting massive particles (SIMP) and displaced vertices
-

Millicharged fermions

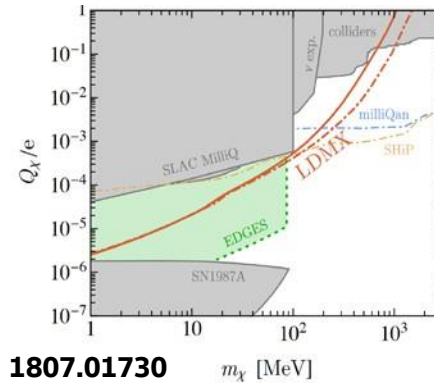

1807.01730 m_χ [MeV]

Axion-like particles

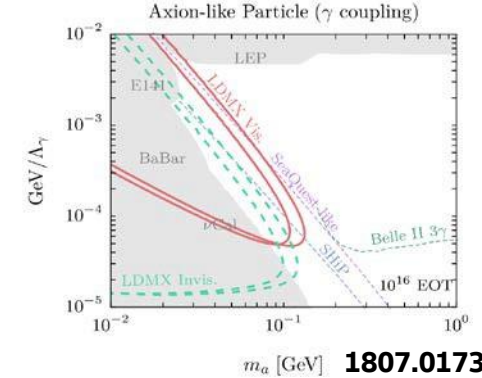

1807.01730 m_a [GeV]

Hidden sector vector meson decay

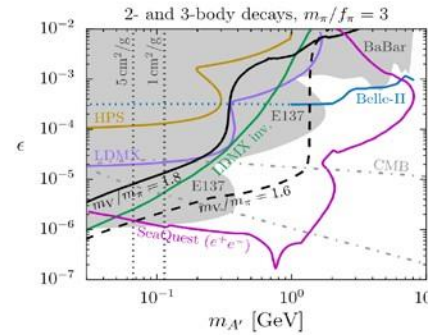

1801.05805

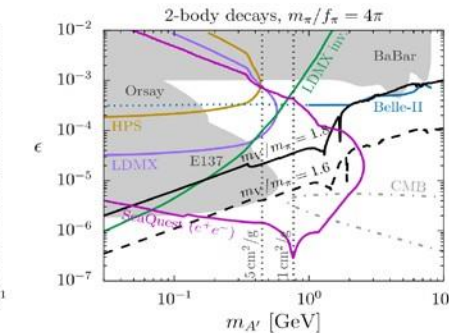
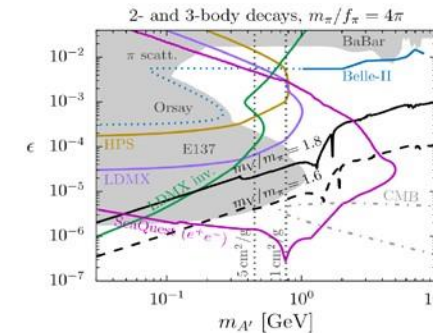
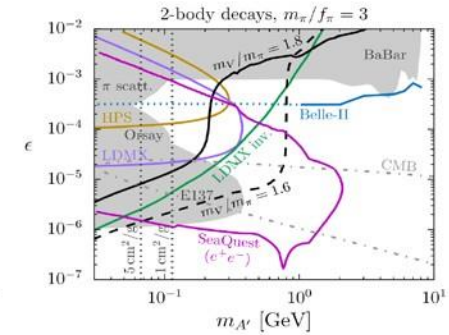

Electron beams – invisible decays

Dark photon decay to DM

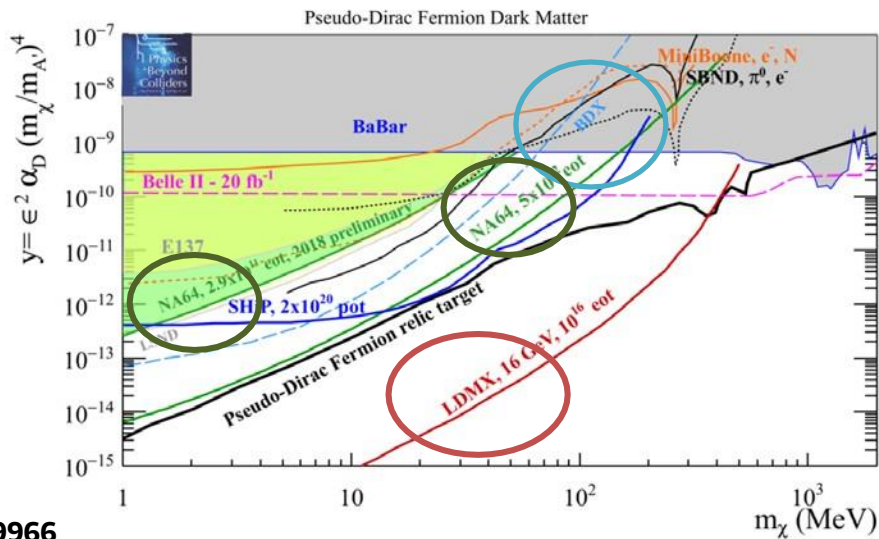
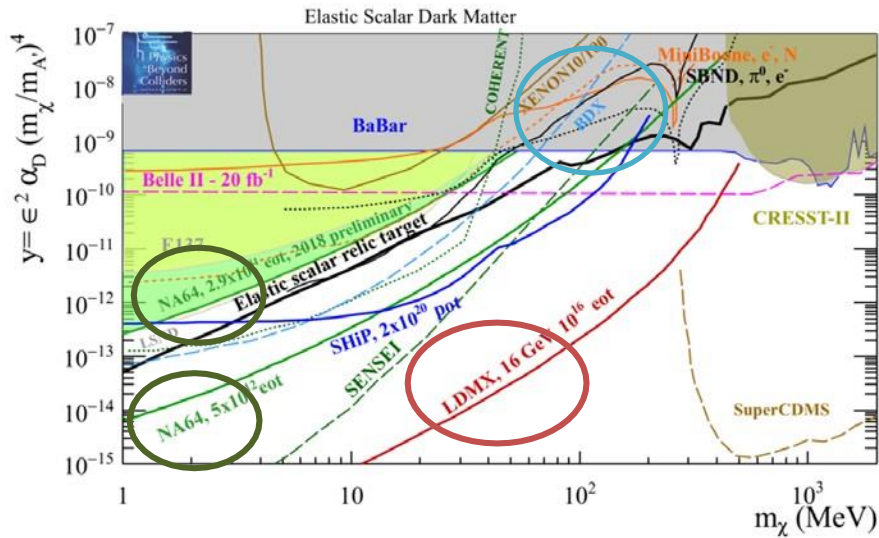

1901.09966

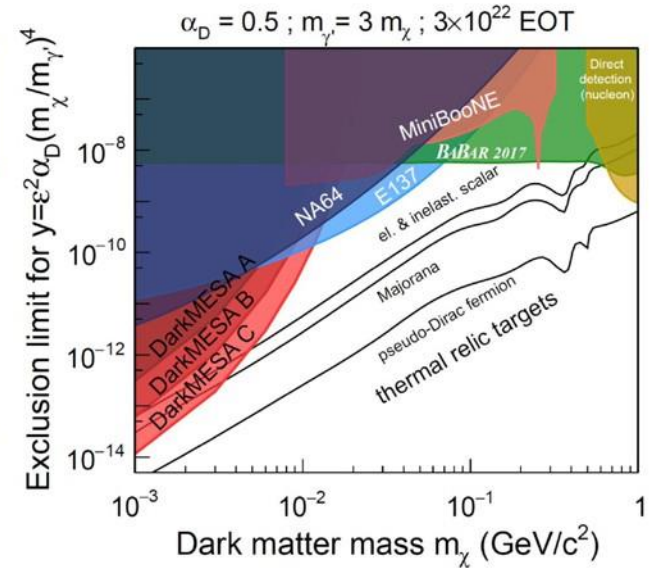

NIMA 958 (2020) 162398

Positron beams - missing mass (fixed target)

PADME @ LNF

- 550 MeV positron beam from the LNF linac
- BGO calorimeter
- PbF_2 small angle fast ECAL
- 10^{12} EOT already collected
 - goal is 10^{13} EOT

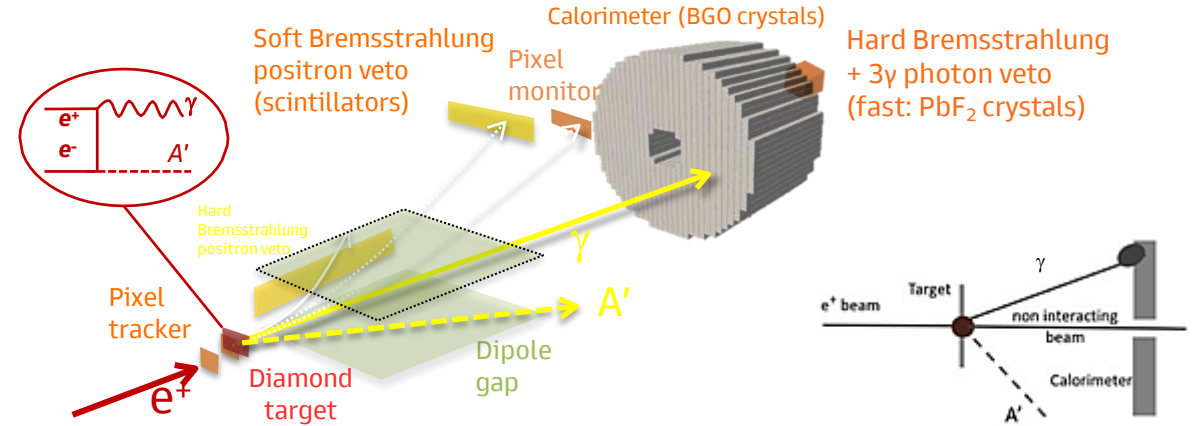

OTHER FACILITIES

- VEPP3: 500 MeV, $10^{15} - 10^{16}$ EOT/ year
- LNF: 550 MeV, $10^{13} - 10^{14}$ EOT/ year
- Cornell: 5.3 GeV, $10^{17} - 10^{18}$ EOT/ year
- JLab (proposal): 11 GeV

Mass coverage is determined by the beam energy

Invisible dark photon

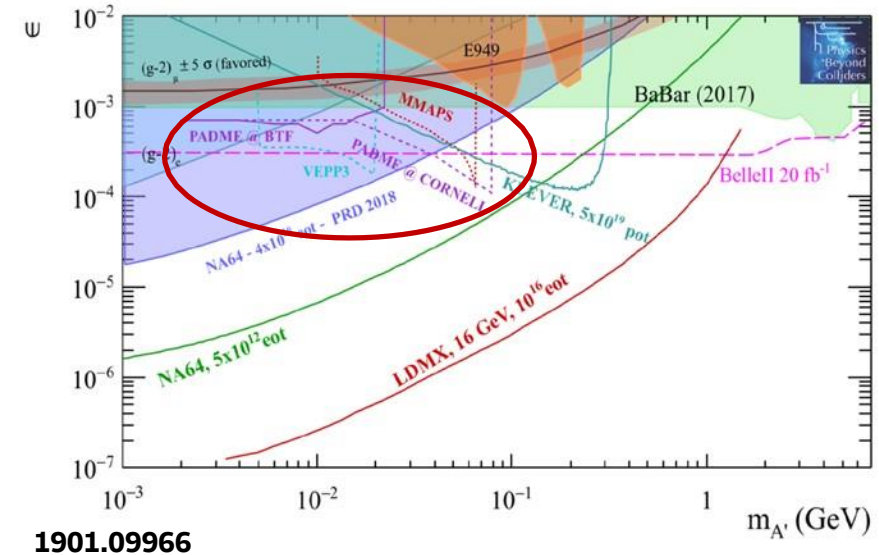

1901.09966

Proton beam dump

DarkQuest @ FNAL

Fixed target experiment at 120 GeV proton beam with short decay volume

- Upgrade of the SeaQuest experiment with an additional calorimeter (2023+)
- Proposed LongQuest upgrade (20??)

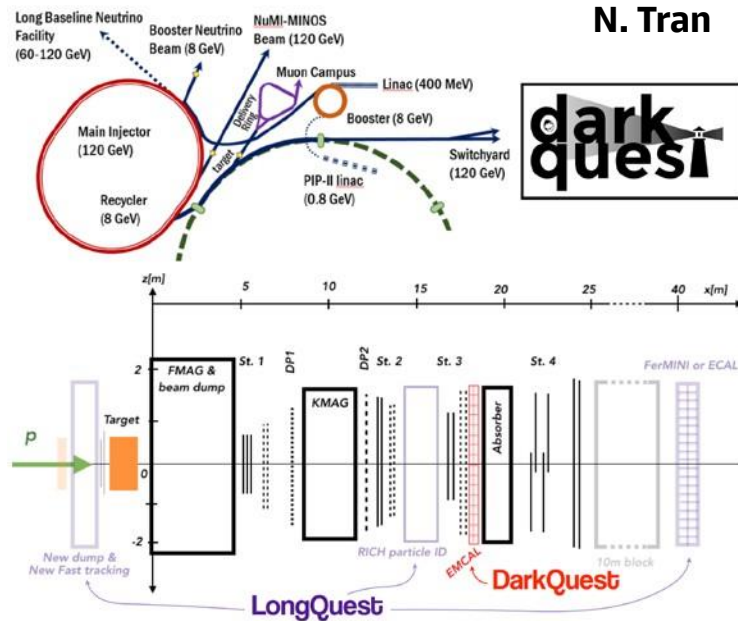

Dark Photon ($A' \rightarrow l^+l^-$)

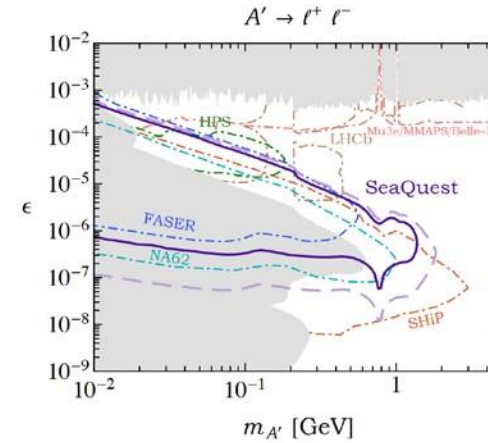

Inelastic DM

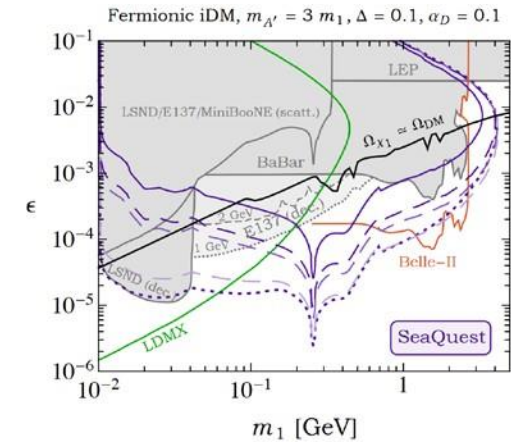

Dark Scalar

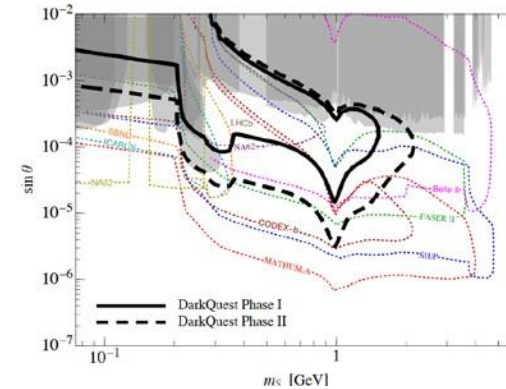

SIMP

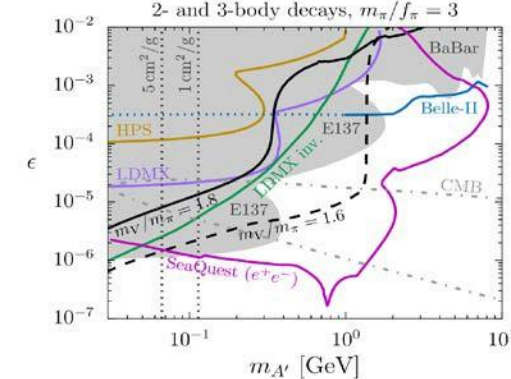

Sensitive to a wide variety of signatures

Proton beam dump

SHIP @ CERN

Proton beam dump experiment to search for dark sector signature and study neutrinos

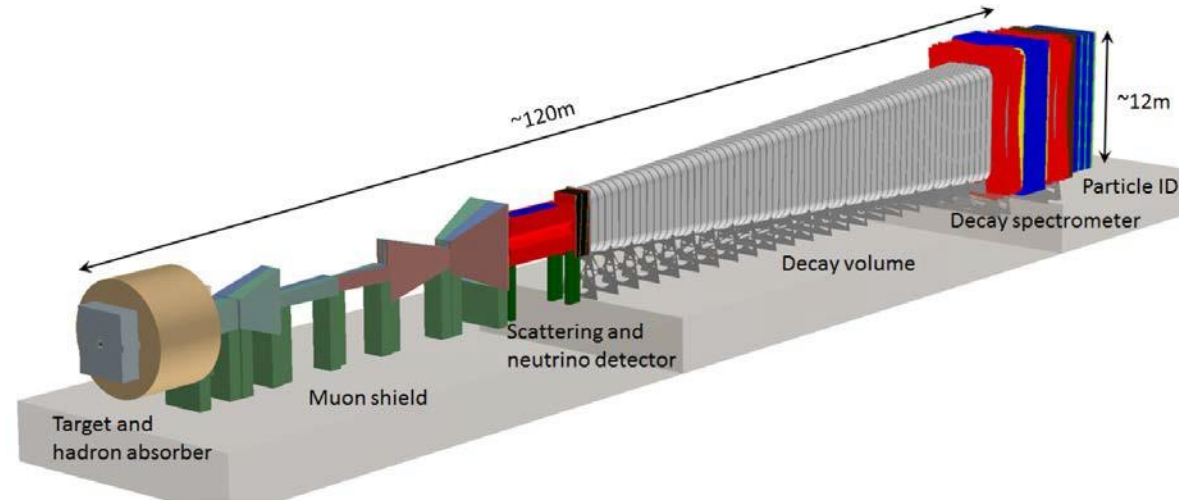

Detector design

- **Two detectors for complementary search strategies:**
 - **Scattering (LDM and neutrino)**
 - **Visible decays (DS particles)**
- **Target and magnetized hadron absorber + active muon shielding → negligible background level ("zero background experiment")**
- **Long decay volume to increase sensitivity to LLP, and decay spectrometer with muon ID capabilities to provide flavor identification**

Proton beam dump

SHIP @ CERN

Dark photon

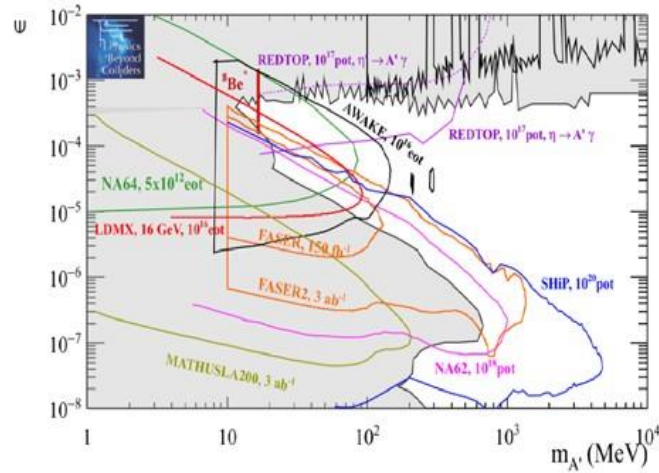

Dark scalar

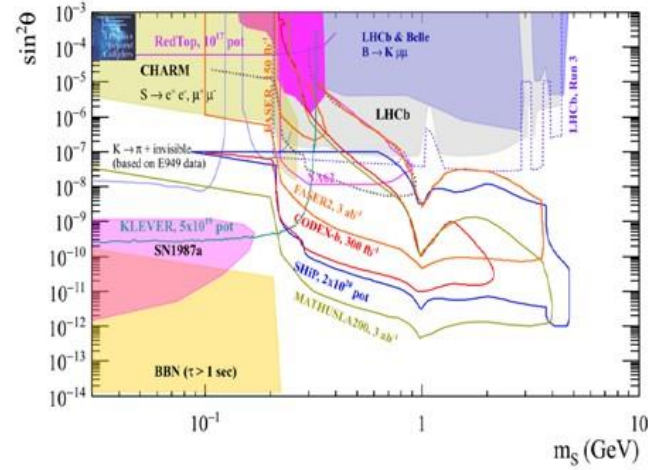

ALP

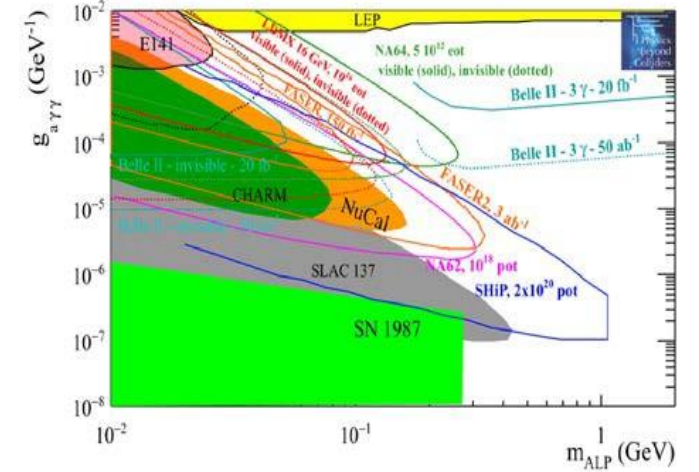

Heavy neutral leptons electron coupling dominated

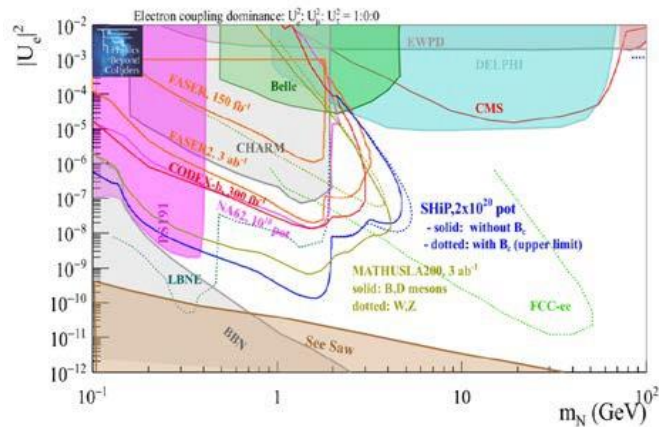

Heavy neutral leptons muon coupling dominated

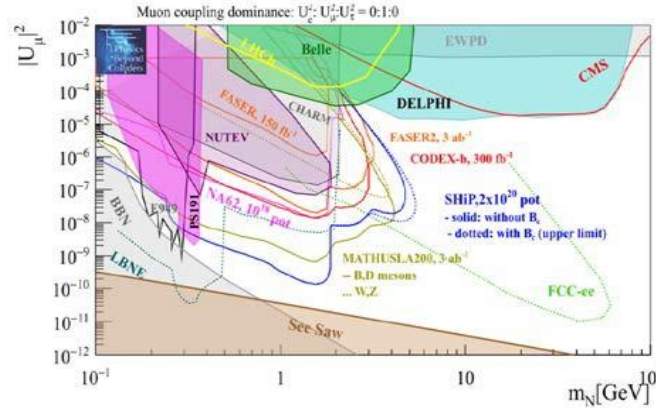

Heavy neutral leptons tau coupling dominated

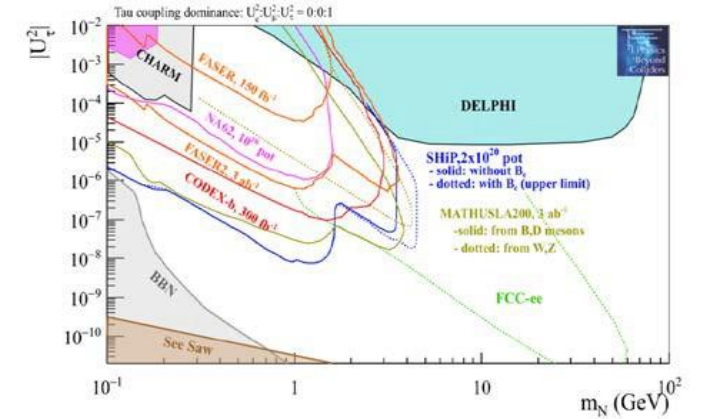

Neutrino experiments

LSND @ LANL

- 170 ton mineral oil detector
- 10^{23} p on water/Cu target (800 MeV)
- Reinterpret electron-neutrino elastic scattering measurement

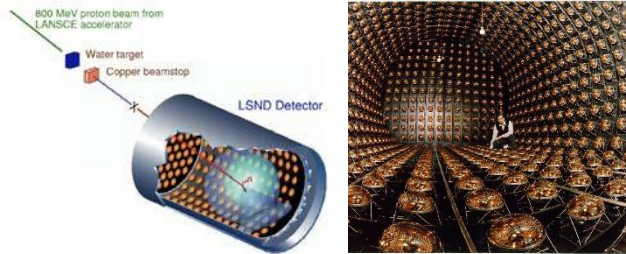

MiniBooNE-DM @ FNAL

- 800 ton mineral oil detector
- 2×10^{19} protons on iron target (8 GeV) with dedicated beam dump run

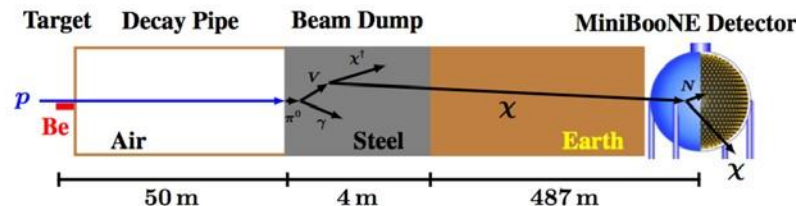

Thermal DM constraints

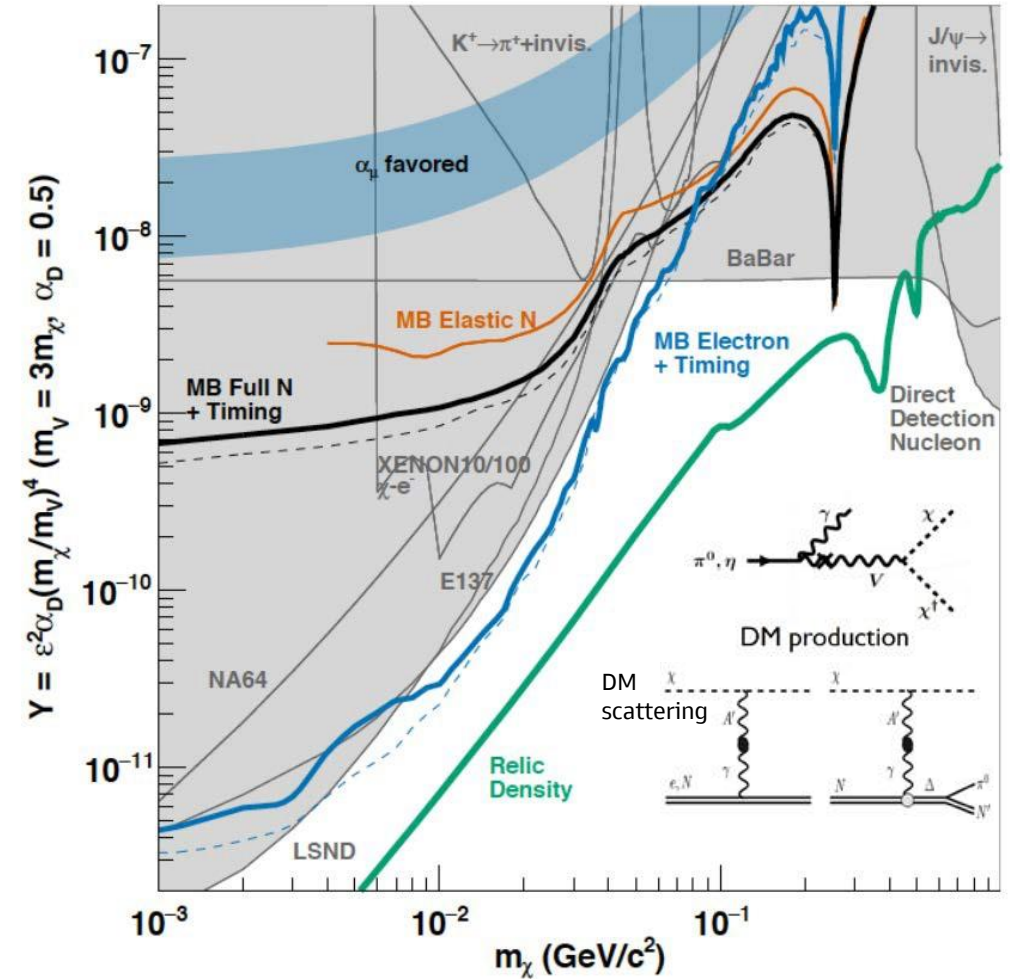

1807.06137

Neutrino experiments

COHERENT @ ORNL

- First observation of Coherent Elastic Neutrino Nucleus Scattering (CEvNS)
- 1 GeV proton beam on target
- Series of detectors ~20m from target
- Sensitivity study to sub-GeV DM for planned 750 kg liquid argon scintillation detector

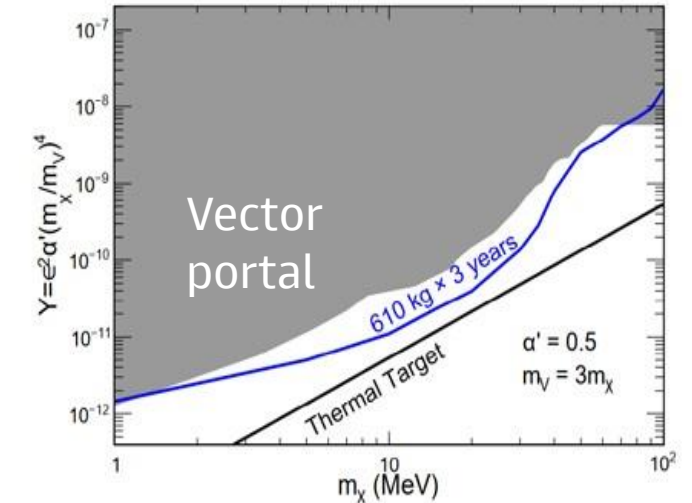
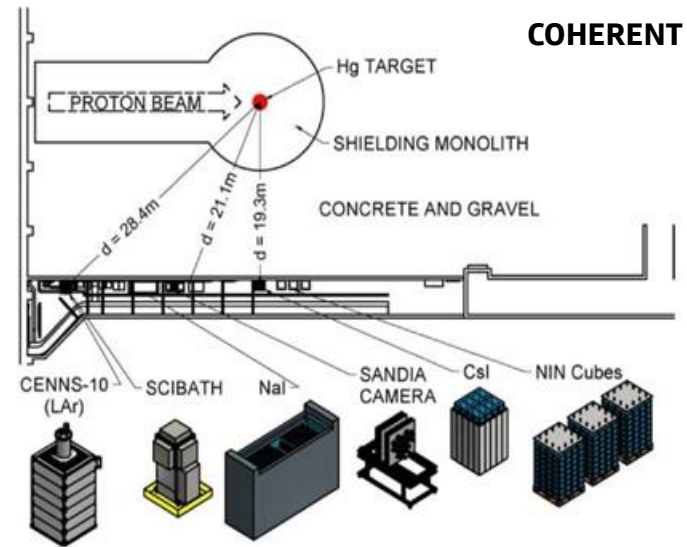

CCM @ LANL

- CEvNS measurement and eV - scale sterile neutrino search
- 10 ton Liquid Argon Scintillation detectors – 800 MeV proton on W target
- Prompt DM signal / delayed bkg
- Can potentially probe thermal relic target up to $m_{A'}$ ~50 MeV

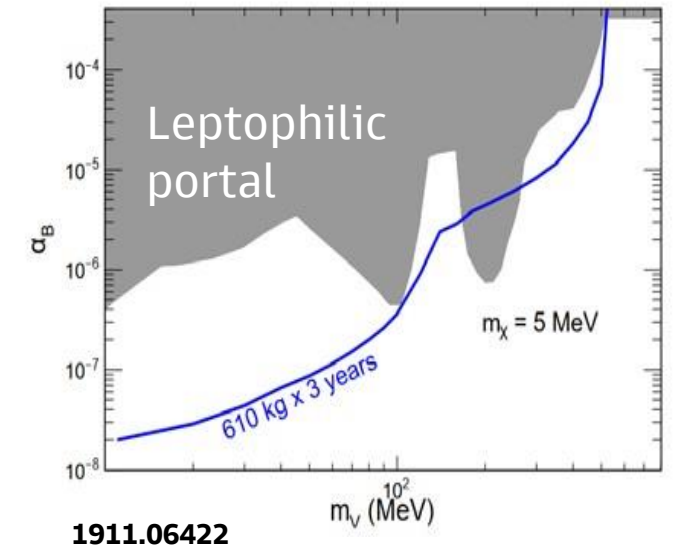

Neutrino experiments

Heavy Neutral Leptons at T2K/ND280

- Collected about 10^{21} POT (30 GeV proton)
- Near Detector ND280 located 280m from proton target
- Kaon decay to HNL ($K^\pm \rightarrow l^\pm N$)
- Limits on mixing elements U^2 down to $\sim 10^{-9}$

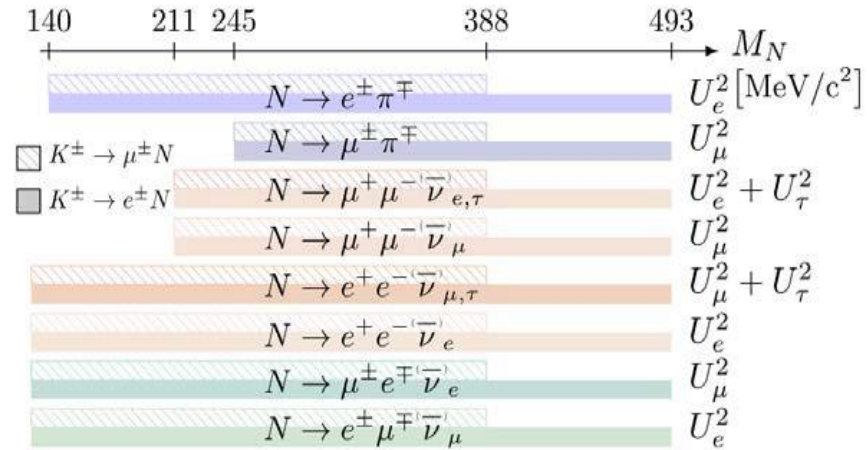

1902.07598

+ MicroBoone (1911.10545)

Higgs portal @ MicroBoone

- Dark scalar produced from kaon decays at rest in proton beam dump
- Long lived scalar decay to e^+e^- pair in detector
- 5 events observed, 2.0 ± 0.8 bkg expected ($< 2\sigma$)
- Probe parameter space suggested by KOTO anomaly

+ projections for SBND (1909.11670)

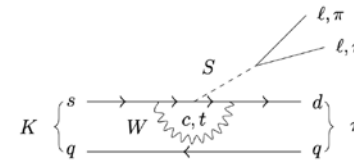

Higgs portal mixing angle

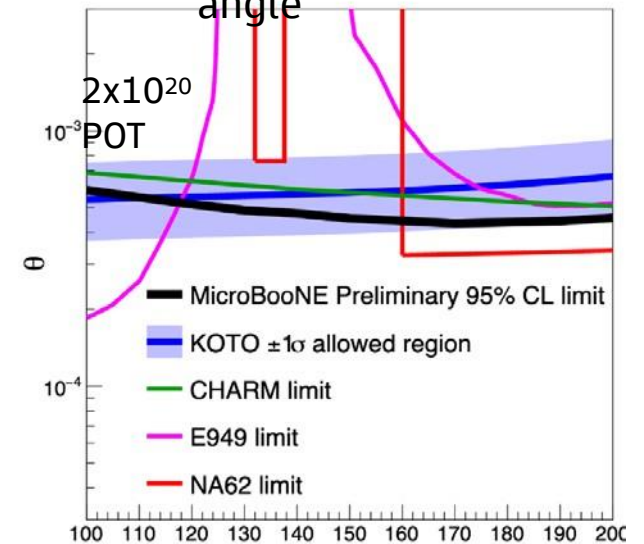

MICROBOONE-NOTE-1092-PUB

Future neutrino experiments

Dune MPD @ FNAL

- Collected $\sim 10^{22}$ POT (120 GeV proton)
- Multi-Purpose Near Detector (MPD) — 1 ton Ar TPC located 574m downstream of target
- Search for dark photon, dark scalar or heavy neutral leptons

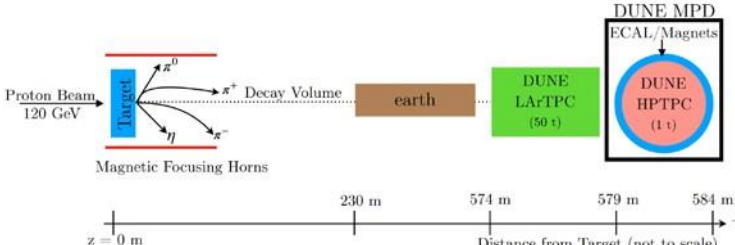

DUNE PRISM @ FNAL

- Movable near detectors (MPD, LArTPC) allows sensitive search to light dark matter
- DM-to-neutrino flux increases as detector is moved further off axis

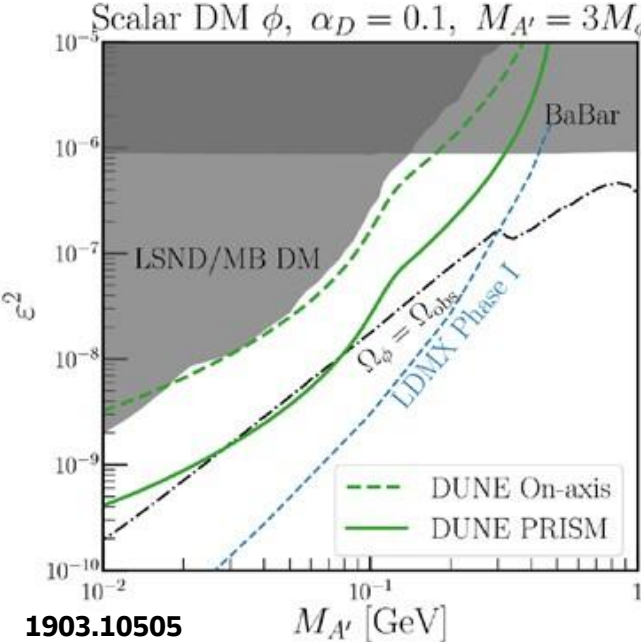

And many other interesting topics (see e.g. 1907.08311)

- Inelastic DM, dark tridents, (sterile) neutrino coupled to dark force, radioactive sources,

Constraints on mixing elements U^2

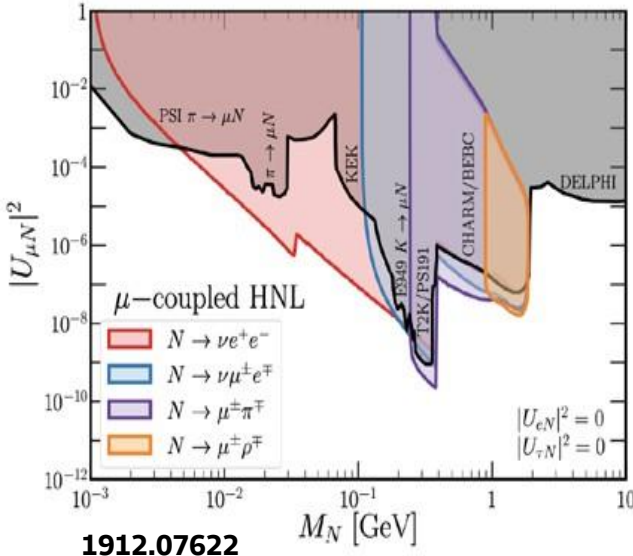

Kaon factories

$$K^\pm \rightarrow \pi^\pm \nu \nu$$



CERN
(running)

$$K_L \rightarrow \pi^0 \nu \nu$$



JPARC
(running)



CERN
(proposal)

Probe dark sector in

- $K \rightarrow \pi + \text{invisible}$
- $K \rightarrow \pi + \text{visible} (\rightarrow ee, \gamma\gamma)$
- $\pi^0 \rightarrow \gamma + \text{visible}$,
-

Heavy neutral lepton

$$K \rightarrow e N / K \rightarrow \mu N$$

$$\Gamma(K^\pm \rightarrow l^\pm N) = \Gamma(K^\pm \rightarrow l^\pm \nu_l) \rho(m_N) |U_{lN}|^2$$

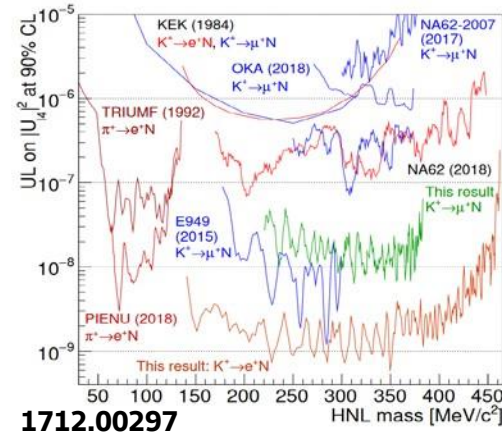

ALP

$$K^+ \rightarrow \pi^+ a (\rightarrow \gamma\gamma), K^0 \rightarrow \pi^0 a (\rightarrow \gamma\gamma)$$

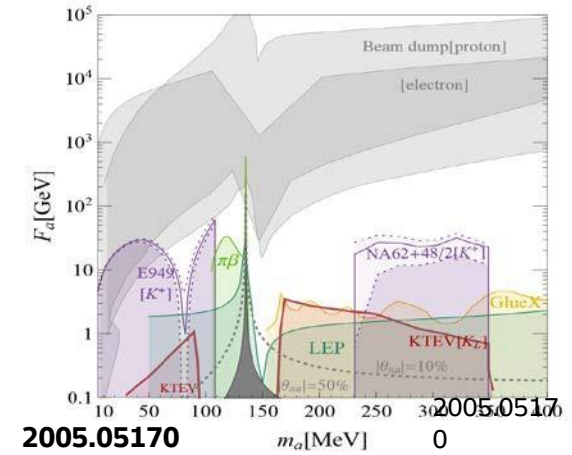

Leptophilic vector

Vector Model: $L_\mu - L_\tau$ Gauge Boson

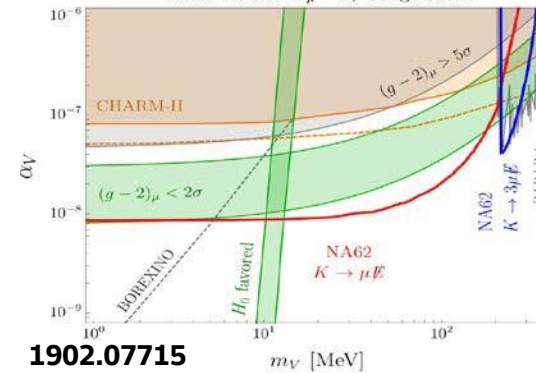

Dark photon (invisible)

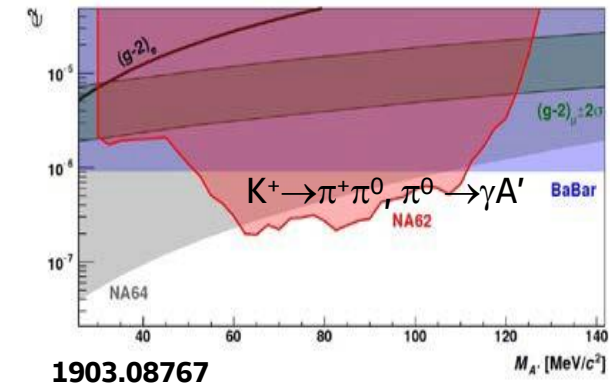

It is possible to run in beam-dump mode to increase FIP production rate

Kaon factories

NA62++ @ CERN

Uses the same apparatus in a "beam dump" mode

- Collect $O(10^{18})$ POT in a few months
- Possibility to run in this mode during Run 3

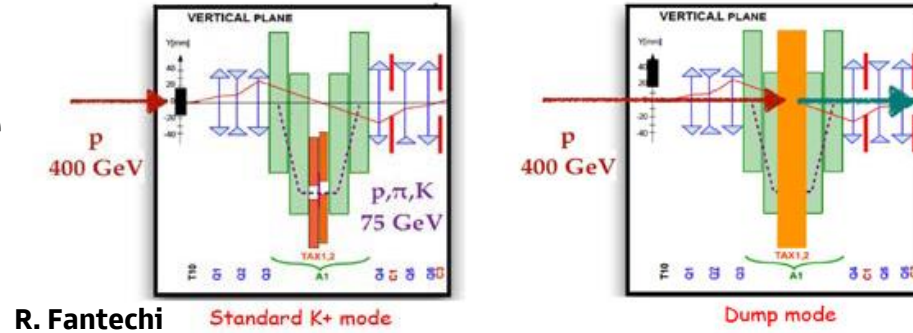

Prospects assuming 10^{18} POT / negligible bkg (a few examples)

Heavy neutral leptons electron coupling-dominated

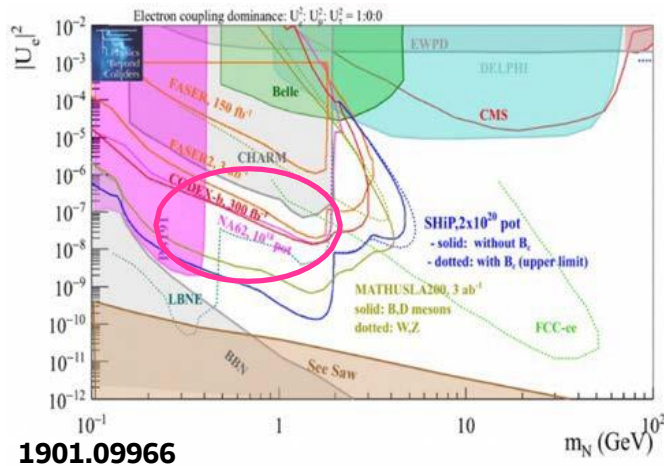

Dark photon

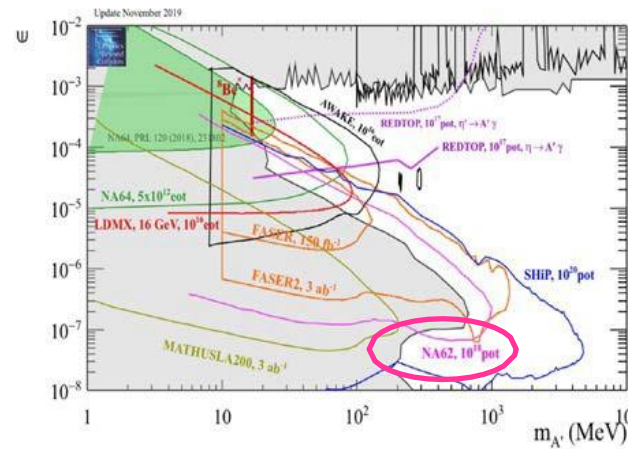

Dark scalar

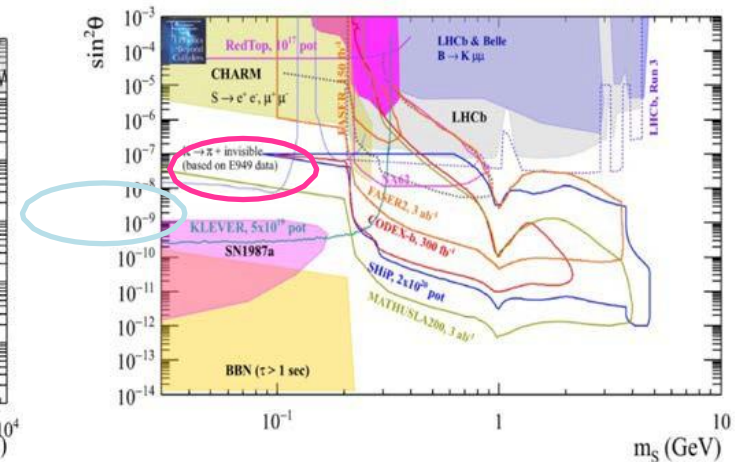

Meson factories

REDTOP @ FNAL or CERN

Proposal for an intense η/η' factory at FNAL or CERN

- Compact detector, optical TPC with dual readout calorimeter
- Aim to collect $10^{12} - 10^{13}$ η /year and $10^{10} - 10^{11}$ η' / year
- Study CP violation, dark photon, dark scalar, baryonic dark force, ALP,...

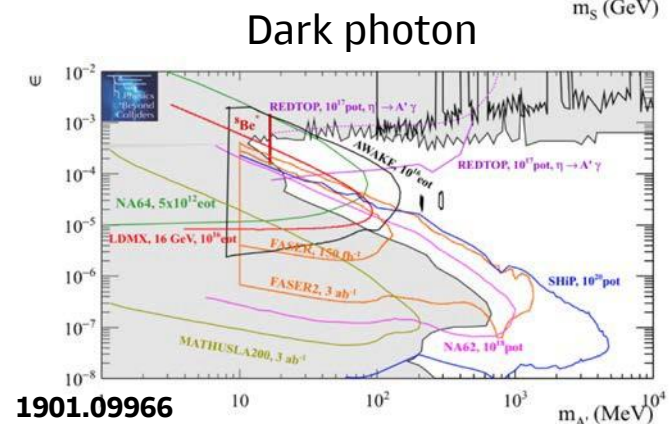
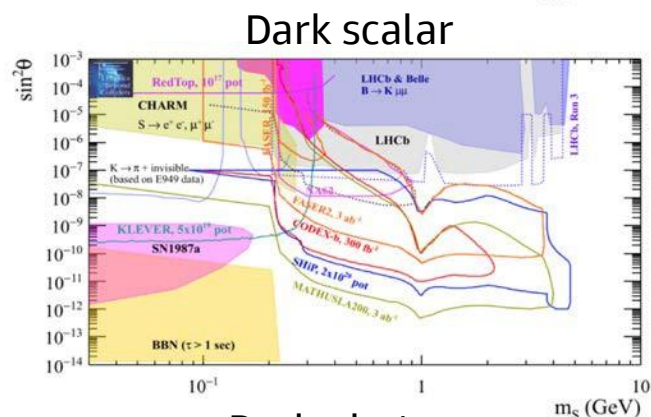
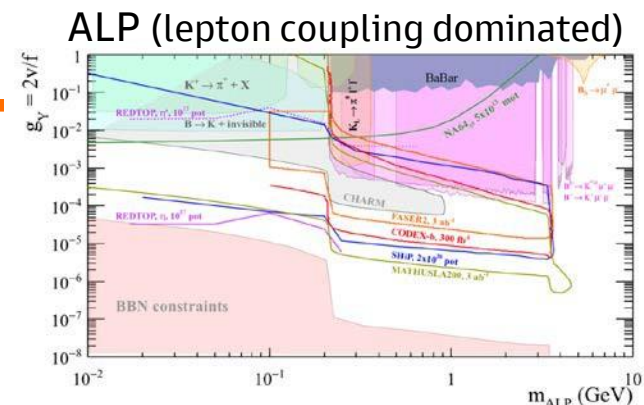
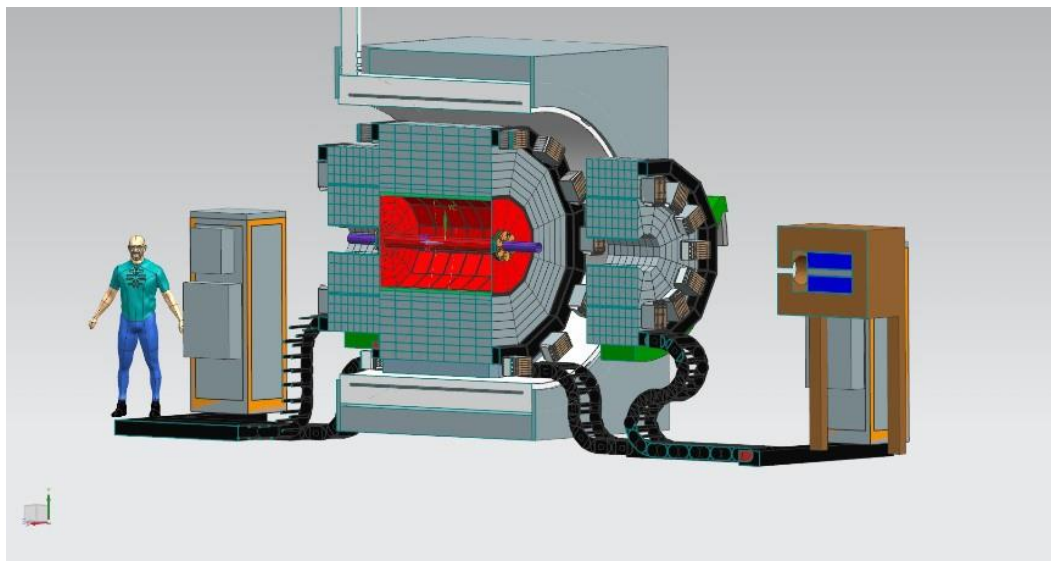

Muon beams

Muon beams

- Can uniquely probe couplings to 2nd generation and flavor agnostic models
- Clean (minimum ionizing) but hard to come by

Two experimental concepts similar to existing missing energy/momentum experiments but with thicker target to make up for lower number of muons on target

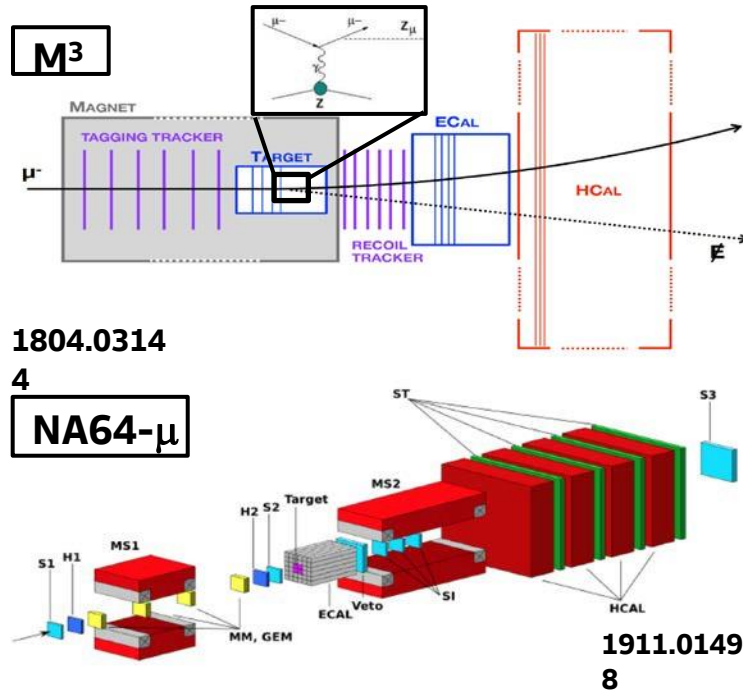

Thermal DM, muonphilic mediator

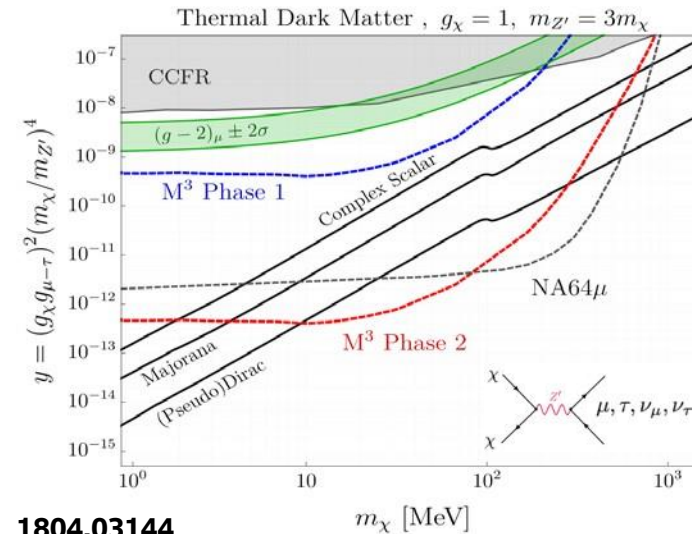

Similar reach for M³ and NA64-μ

+muon beam dumps, high-intensity muon beams

Summary

There is an extensive worldwide program of fixed target and beam dump experiments that will be crucial to search for weakly-interacting particles as close as possible to the thermal relic limit

Extracted beams have unique sensitivity to a large fraction of the parameter space of many models. Future experiments will improve limits by several orders of magnitude

A wide variety of beam and techniques can be used to probe various types of couplings and final states, complementing collider measurements

Many of these dark sector searches can be performed at existing facilities or experiments