



XIII International Conference on New Frontiers in Physics

Azimuthal transverse single-spin asymmetries of inclusive jets and hadrons within jets from polarized pp collisions at $\sqrt{s} = 510$ GeV at STAR

Yixin Zhang (张宜新),
for the STAR Collaboration
Shandong University (山东大学)



Supported in part by



U.S. DEPARTMENT OF
ENERGY

Office of
Science

Challenges in Transverse Single-Spin Asymmetry (TSSA)



- Anomalously large A_N in pp collisions observed for nearly 40 years

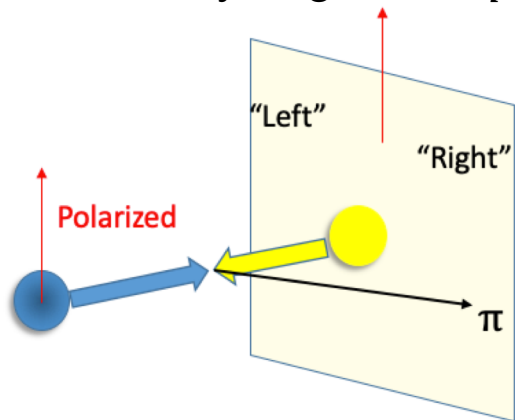

$$A_N = \frac{d\sigma^\uparrow - d\sigma^\downarrow}{d\sigma^\uparrow + d\sigma^\downarrow}$$

- LO QCD predicts $A_N \sim 0$

G. Kane, J. Pumplin, W. Repko, Phys. Rev. Lett 41,1689 (1978).

- Left-right asymmetries of different collaborations at different beam energies

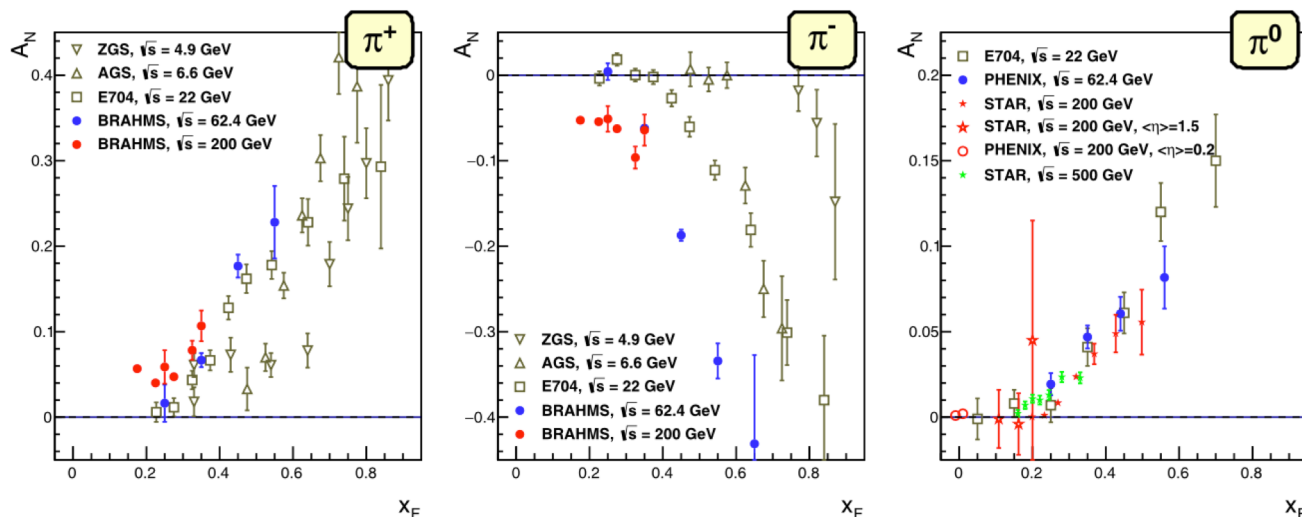

E. C. Aschenauer et al. arXiv:1602.03922

- Stable in different C.M. energies
- Interpreted by the twist-3 and transverse-momentum-dependent (TMD) formalisms

$$x_F = \frac{2p_z}{\sqrt{s}}$$

Mechanisms for Transverse Single-Spin Asymmetry

➤ Transverse Momentum Dependent (TMD) parton distributions and fragmentation functions.

- Need two scales (Q and p_T), $Q \gg p_T$

✓ **Sivers effect (Sivers'90):**

Parton spin and k_\perp correlation in initial state (related to orbital angular momentum)

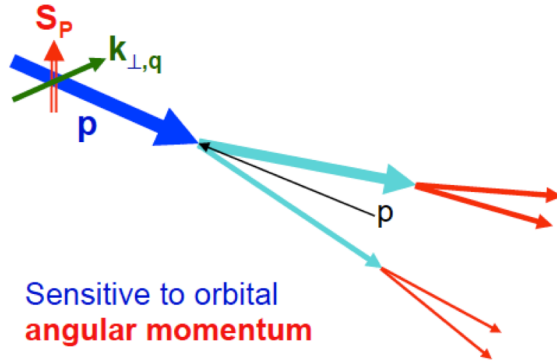

$$\vec{S} \cdot (\vec{p} \times \vec{k}_\perp)$$

✓ **Collins effect (Collins'93):**

Quark spin and k_\perp correlation in fragmentation process (coupled with transversity)

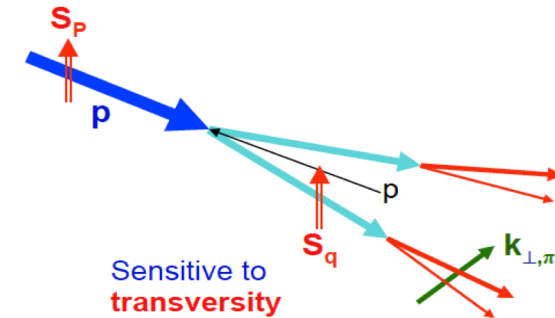

➤ Twist-3 mechanism (Efremov-Teryaev'82, Qiu-Sterman'91):

- Collinear/twist-3 quark-gluon correlation + fragmentation functions
- Need one scale (Q or p_T), $Q, p_T \gg \Lambda_{QCD}$
- Consistent with TMD mechanism in the overlapping kinematics region

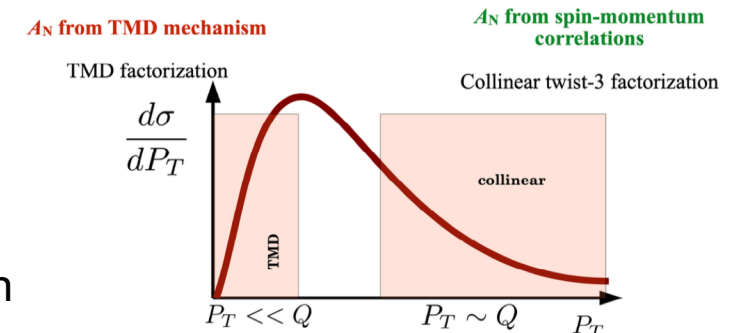

X. Ji, J.-W. Qiu, W. Vogelsang, and F. Yuan, *Phys. Rev. Lett.* 97, 082002 (2006)

TSSA of pp Collisions

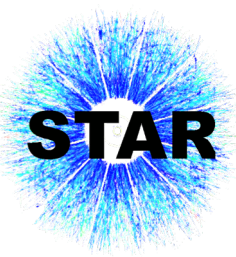

➤ Transversely polarized proton-proton collision data in recent years at STAR

Year	2011	2012	2015	2017	2022
\sqrt{s} (GeV)	500	200	200	510	508
L_{int} (pb^{-1})	25	14	52	350	400
Polarization	53%	57%	57%	55%	52%

- Measurements at RHIC can reach values of Q^2 that are more than two orders of magnitude higher than current SIDIS experiments

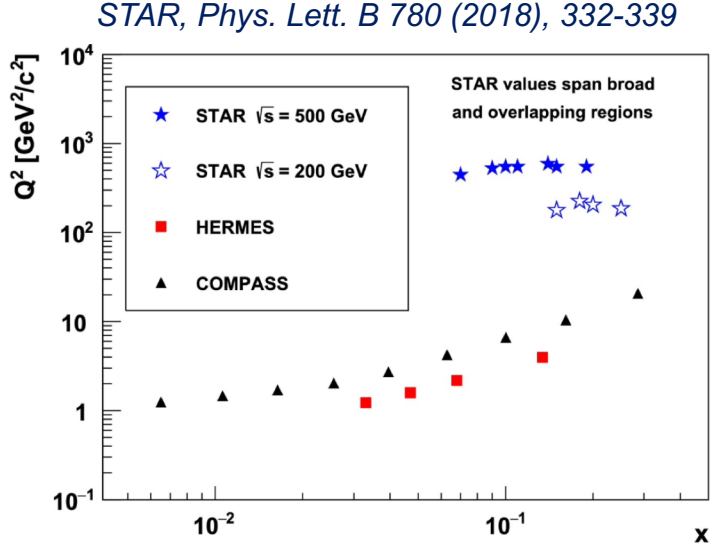

➤ Collins effect for hadron within jet at STAR

- Separate initial and final state effects
- Jet- $p_T \sim$ hard scale; hadron $p_T \sim$ soft scale
- Validate factorization and universality with SIDIS and e^+e^- annihilation

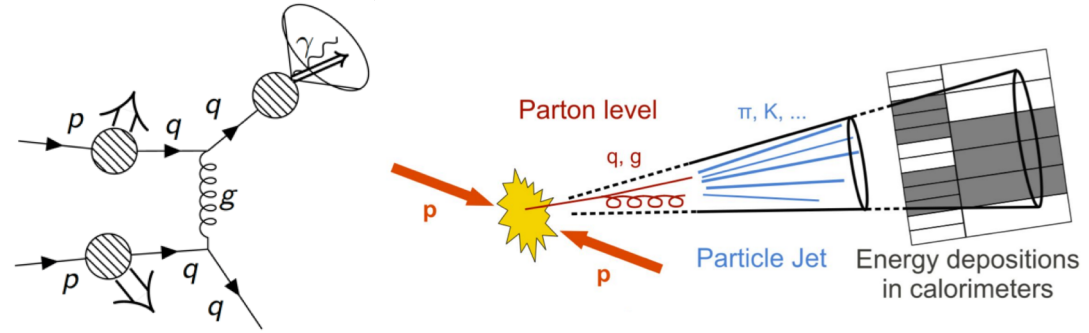

Z. B. Kang, X. Liu, F. Ringer and H. Xing, *JHEP* 11 (2017), 068
 U. D'Alesio, F. Murgia and C. Pisano, *Phys. Lett. B* 773 (2017), 300-306

Relativistic Heavy Ion Collider (RHIC)

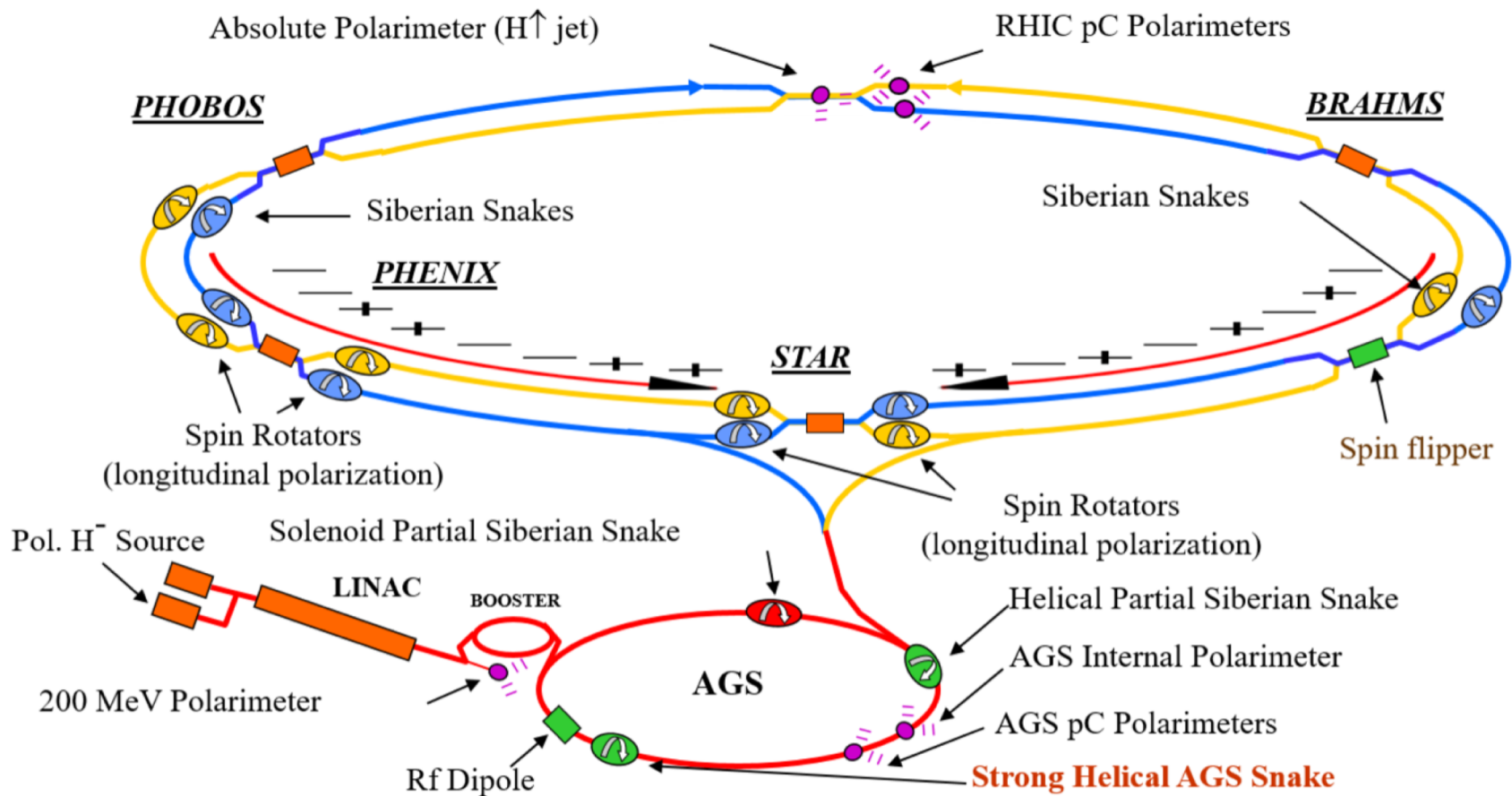

➤ RHIC is the world's only machine capable of colliding high-energy polarized protons

The Solenoidal Tracker At RHIC (STAR)

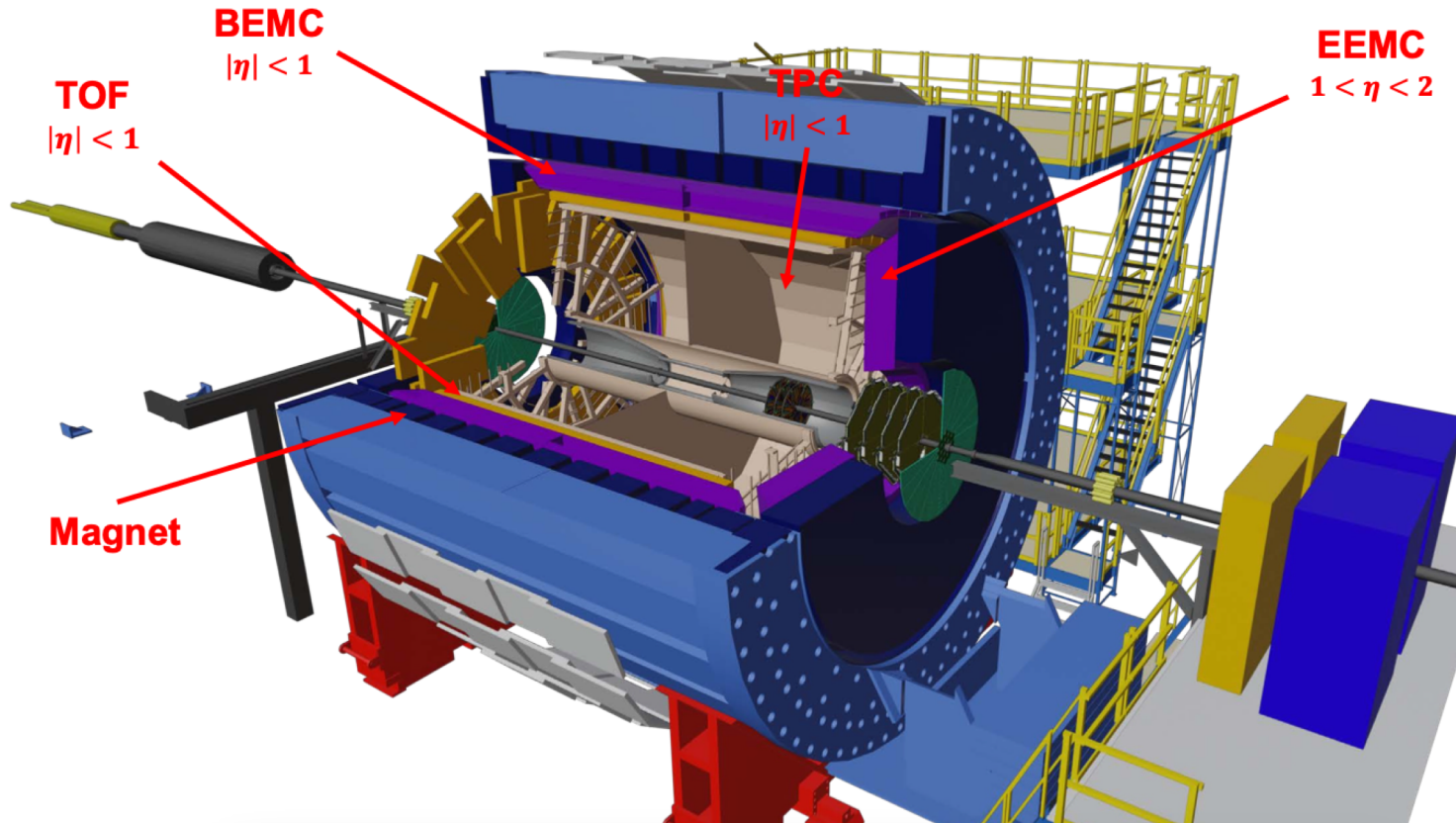
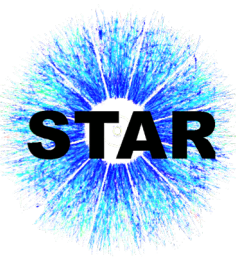

- **T**ime **P**rojection **C**hamber (TPC)
 - $|\eta| < 1$ and $\phi \in [0, 2\pi]$
 - Main detector for tracking and PID
- **T**ime **O**f **F**light (TOF)
 - $|\eta| < 1.0$ and $\phi \in [0, 2\pi]$
 - Improve PID of tracks
- **E**lectro**M**agnetic **C**alorimeter
 - BEMC: $|\eta| < 1.0$ and $\phi \in [0, 2\pi]$.
 - EEMC: $1.08 < \eta < 2.0$ and $\phi \in [0, 2\pi]$
 - Reconstruction of photon, e , π^0 and triggering

Jet Reconstruction

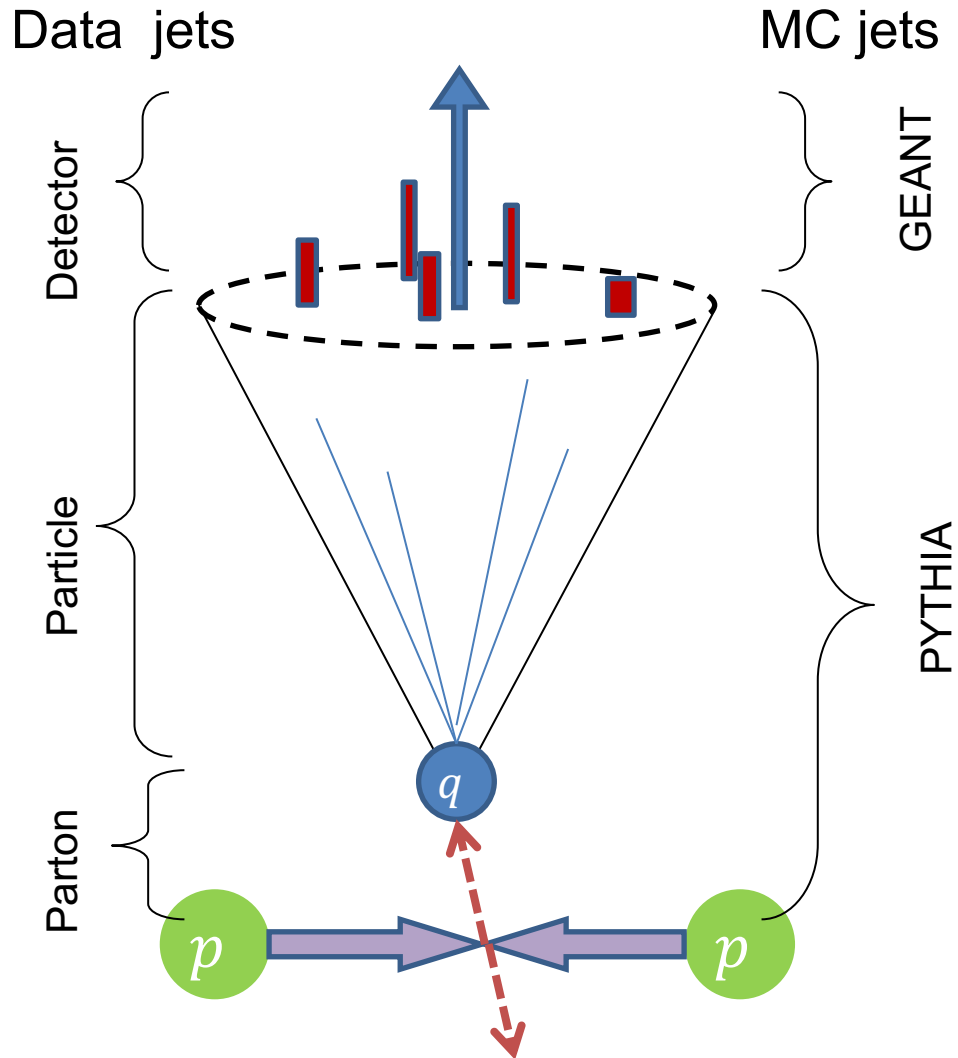

➤ Jet reconstruction :

- Anti- K_T algorithm with $R = 0.5$
- TPC tracks and EMC energy deposition as input
- Off-axis cone method to estimate underlying event contribution

➤ Simulation

- PYTHIA 6.4 with STAR adjustment of Perugia 2012
- Kinematic correction & Systematic uncertainty estimation

Angle Modulations of TSSA in pp Collisions



➤ For π^\pm within jets in pp collisions, the spin dependent cross section can be expressed:

$$\frac{d\sigma^\uparrow(\phi_S, \phi_H) - d\sigma^\downarrow(\phi_S, \phi_H)}{d\sigma^\uparrow(\phi_S, \phi_H) + d\sigma^\downarrow(\phi_S, \phi_H)} \propto \begin{aligned} & A_{UT}^{\sin(\phi_S)} \sin(\phi_S) && \text{related to Sivers effect} \\ & + A_{UT}^{\sin(\phi_S - \phi_H)} \sin(\phi_S - \phi_H) && \text{related to Collins effect} \\ & + A_{UT}^{\sin(\phi_S - 2\phi_H)} \sin(\phi_S - 2\phi_H) && \text{related to Collins-like effect} \\ & + A_{UT}^{\sin(\phi_S + \phi_H)} \sin(\phi_S + \phi_H) \\ & + A_{UT}^{\sin(\phi_S + 2\phi_H)} \sin(\phi_S + 2\phi_H) \end{aligned}$$

- ϕ_S : azimuthal angle between the proton transverse spin polarization vector and jet scattering plane.
- ϕ_H : azimuthal angle of pion relative to the jet scattering plane.

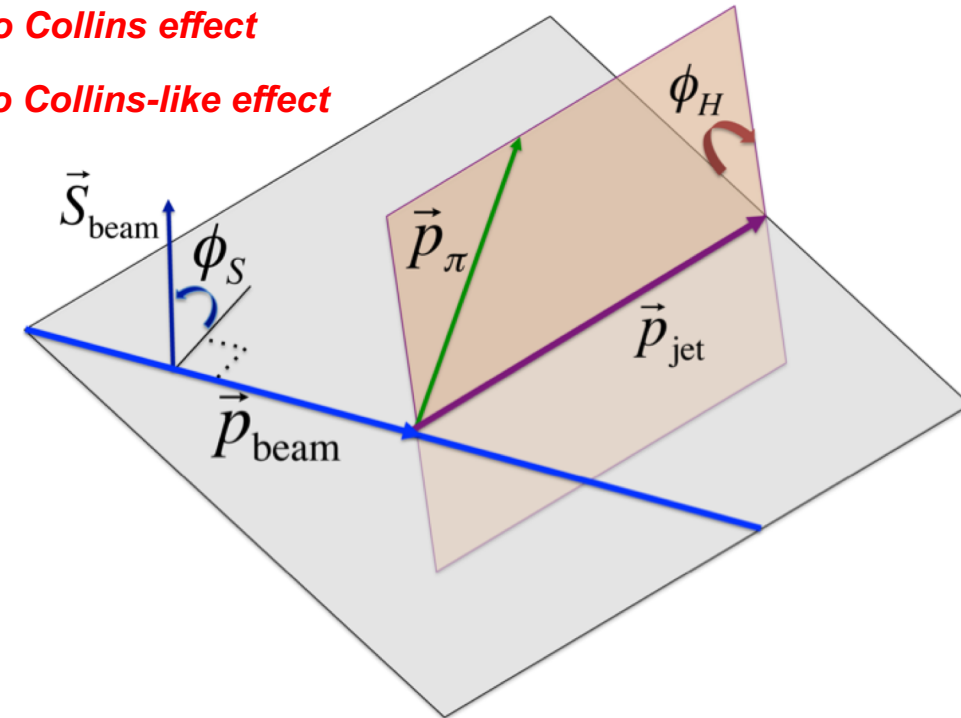

STAR, Phys. Rev. D 97, 032004 (2018)

Extraction of Transverse Single-Spin Asymmetries

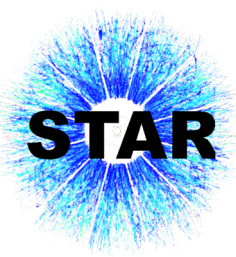

- Cross-ratio method to extract the asymmetries of different modulations.

$$A_N \sin(\phi) = \frac{1}{P} \cdot \frac{\sqrt{N^\uparrow(\phi)N^\downarrow(\phi + \pi)} - \sqrt{N^\downarrow(\phi)N^\uparrow(\phi + \pi)}}{\sqrt{N^\uparrow(\phi)N^\downarrow(\phi + \pi)} + \sqrt{N^\downarrow(\phi)N^\uparrow(\phi + \pi)}}$$

- Cross ratio method can cancel detector efficiencies and spin dependent luminosity.
- N^\uparrow (or N^\downarrow) is the yield for a given spin state.



Particle Identification

➤ Particle identification with TOF unmatched (left) and matched (right)

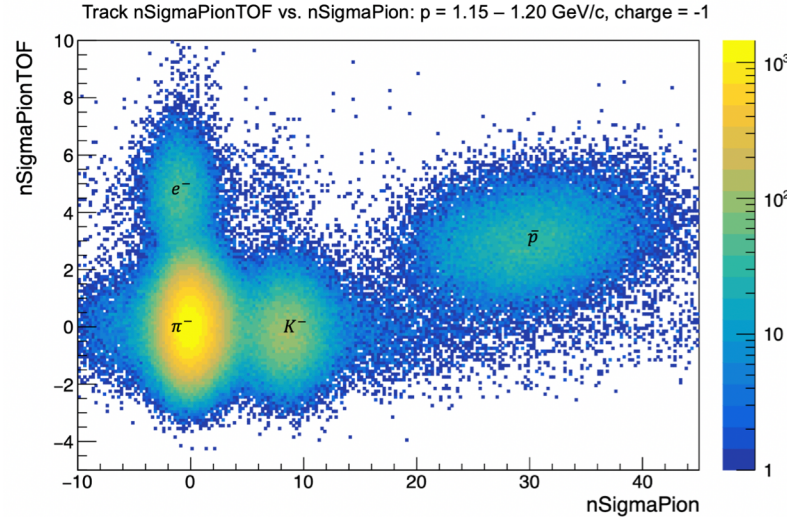
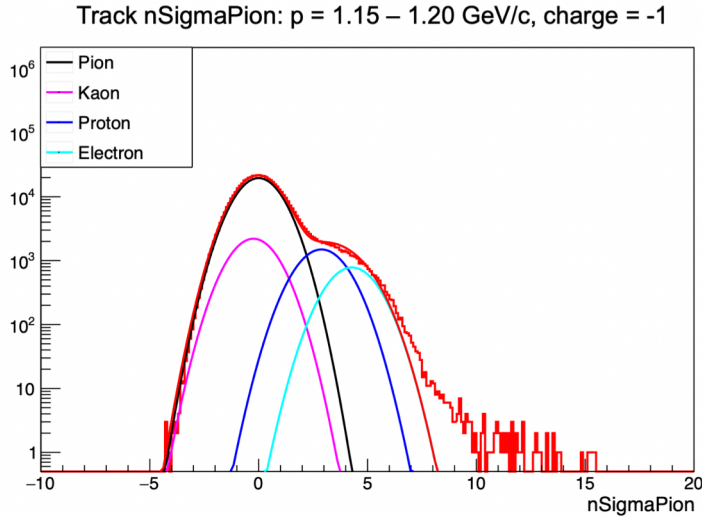

$$n\sigma_{dE/dx} = \frac{1}{\sigma_{\text{exp}}} \ln \left(\frac{dE/dx_{\text{meas}}}{dE/dx_{\text{theo}}} \right)$$

$$n\sigma_{TOF} = \frac{TOF_{\text{meas}} - \frac{L}{c\beta(p)}}{\sigma_{\text{eff}}}$$

➤ Asymmetries purification through Moore-Penrose inverse.

$$\begin{pmatrix} f_{\pi \text{ rich}}^{\pi TOF} & f_{\pi \text{ rich}}^{K TOF} & f_{\pi \text{ rich}}^{p TOF} \\ f_{K \text{ rich}}^{\pi TOF} & f_{K \text{ rich}}^{K TOF} & f_{K \text{ rich}}^{p TOF} \\ f_{p \text{ rich}}^{\pi TOF} & f_{p \text{ rich}}^{K TOF} & f_{p \text{ rich}}^{p TOF} \\ f_{\pi \text{ rich}}^{\pi dE/dx} & f_{\pi \text{ rich}}^{K dE/dx} & f_{\pi \text{ rich}}^{p dE/dx} \\ f_{K \text{ rich}}^{\pi dE/dx} & f_{K \text{ rich}}^{K dE/dx} & f_{K \text{ rich}}^{p dE/dx} \\ f_{p \text{ rich}}^{\pi dE/dx} & f_{p \text{ rich}}^{K dE/dx} & f_{p \text{ rich}}^{p dE/dx} \end{pmatrix} \begin{pmatrix} A_{\pi \text{ pure}} \\ A_{K \text{ pure}} \\ A_{p \text{ pure}} \end{pmatrix} = \begin{pmatrix} A_{\pi \text{ raw}}^{TOF} \\ A_{K \text{ raw}}^{TOF} \\ A_{p \text{ raw}}^{TOF} \\ A_{\pi \text{ raw}}^{dE/dx} \\ A_{K \text{ raw}}^{dE/dx} \\ A_{p \text{ raw}}^{dE/dx} \end{pmatrix}$$

- $f_{i \text{ rich}}^j$: the fraction of particle type j in the i -rich sample.
- Subtract other particles contamination

Sivers Asymmetry of Inclusive Jet at 200 GeV & 510 GeV

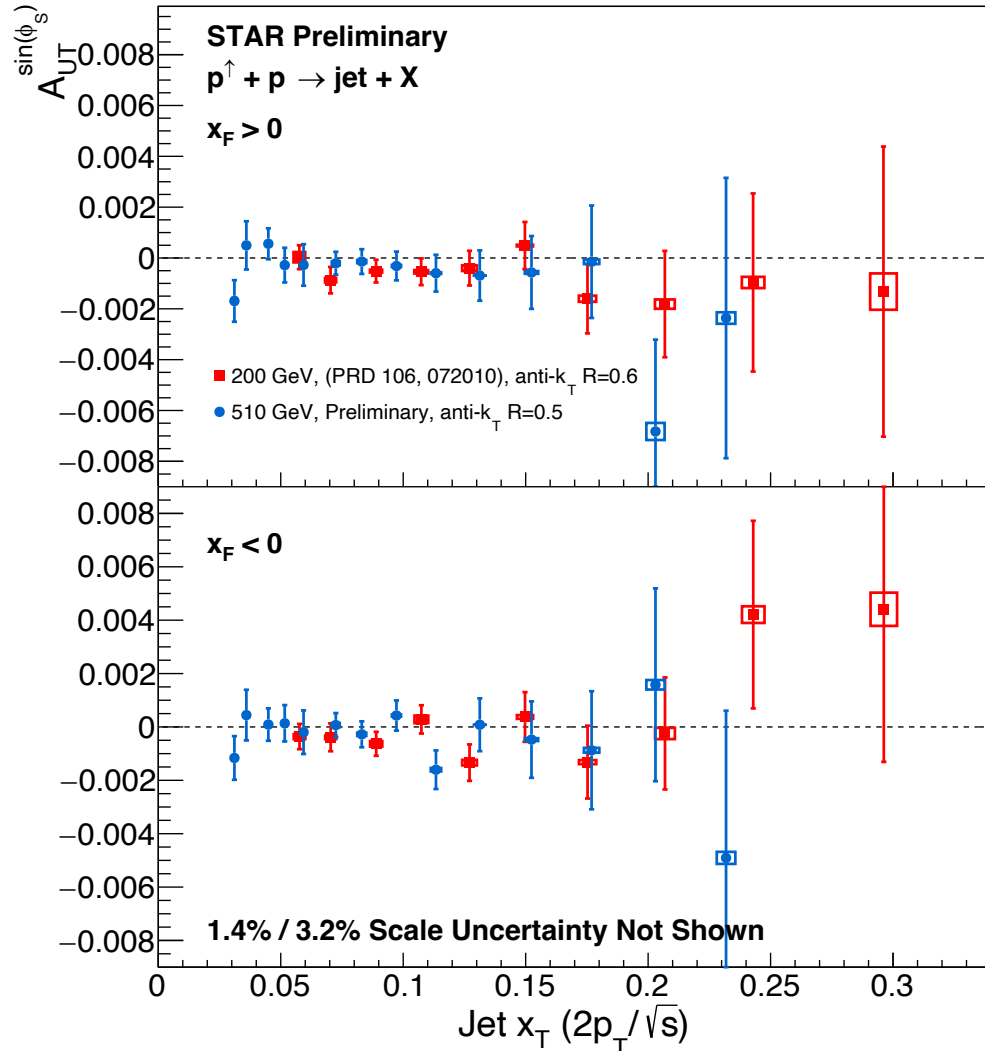
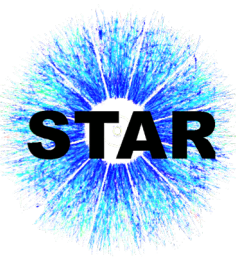

- Sivers asymmetries for inclusive jets are consistent with 0.
- Sensitive to twist-3 correlators associated with the gluon Sivers function
- The forward-upgraded STAR detector may observe non-zero signal

AnDY Collaboration, Phys. Lett. B 750 (2015) 660

Sivers Asymmetry of Hadron-Tagged Jet at 200 GeV & 510 GeV

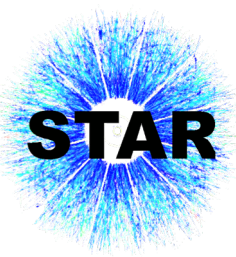

M. Abdallah et al. [STAR], Phys. Rev. D 106, 072010 (2022)

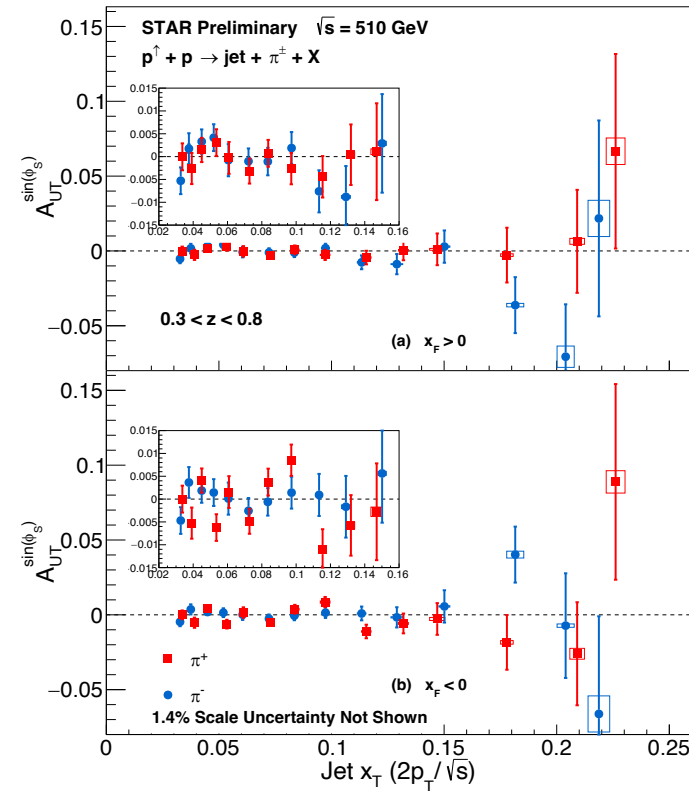
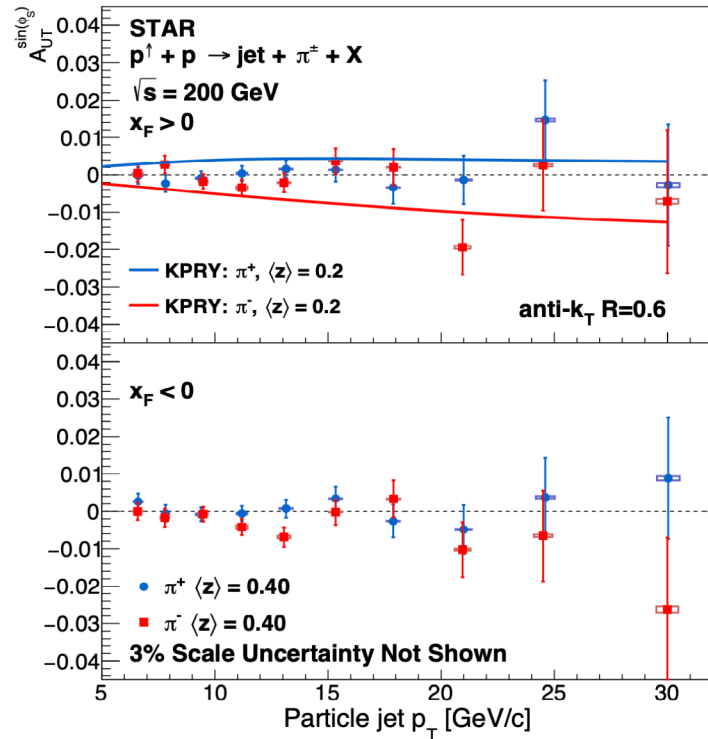

- Quark jet fractions are enhanced by tagging π^\pm
- Asymmetries are consistent with zero at mid-rapidity
- Theoretical expectations from the KPRY model

Z. B. Kang, A. Prokudin, F. Ringer and F. Yuan, Phys. Lett. B 774 (2017)

Collins Asymmetry of pion at 510/500 GeV



➤ Collins results as a function of jet p_T

- Positive for π^+ and negative for π^- , and increase with increasing jet p_T for $x_F > 0$
- The asymmetries for $x_F < 0$ are consistent with 0.

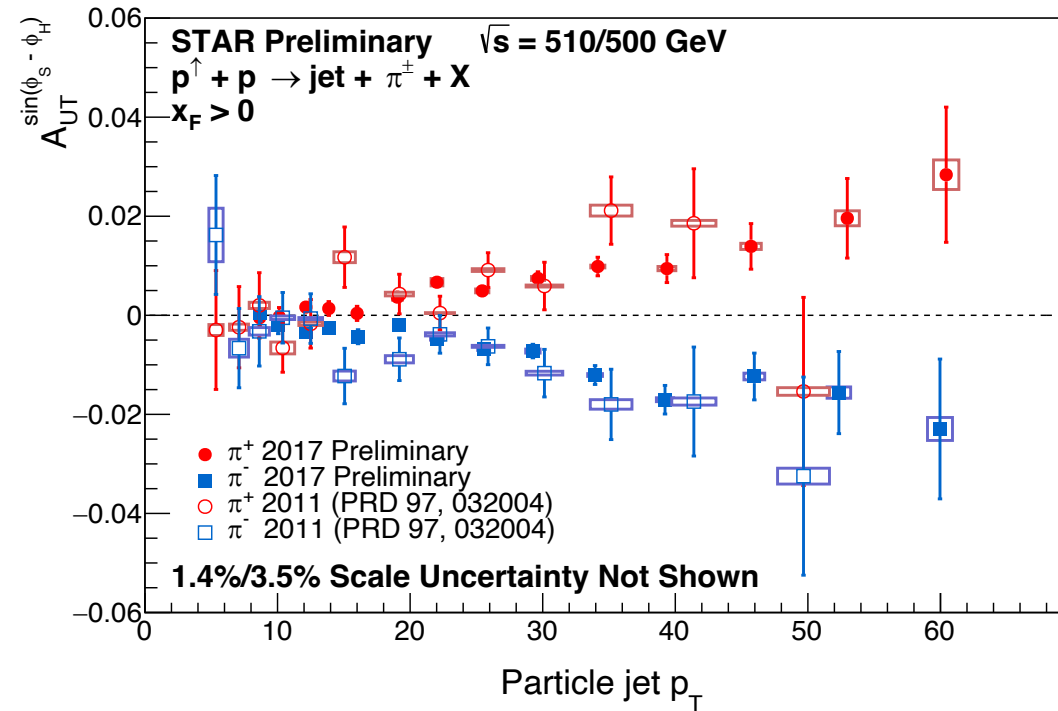
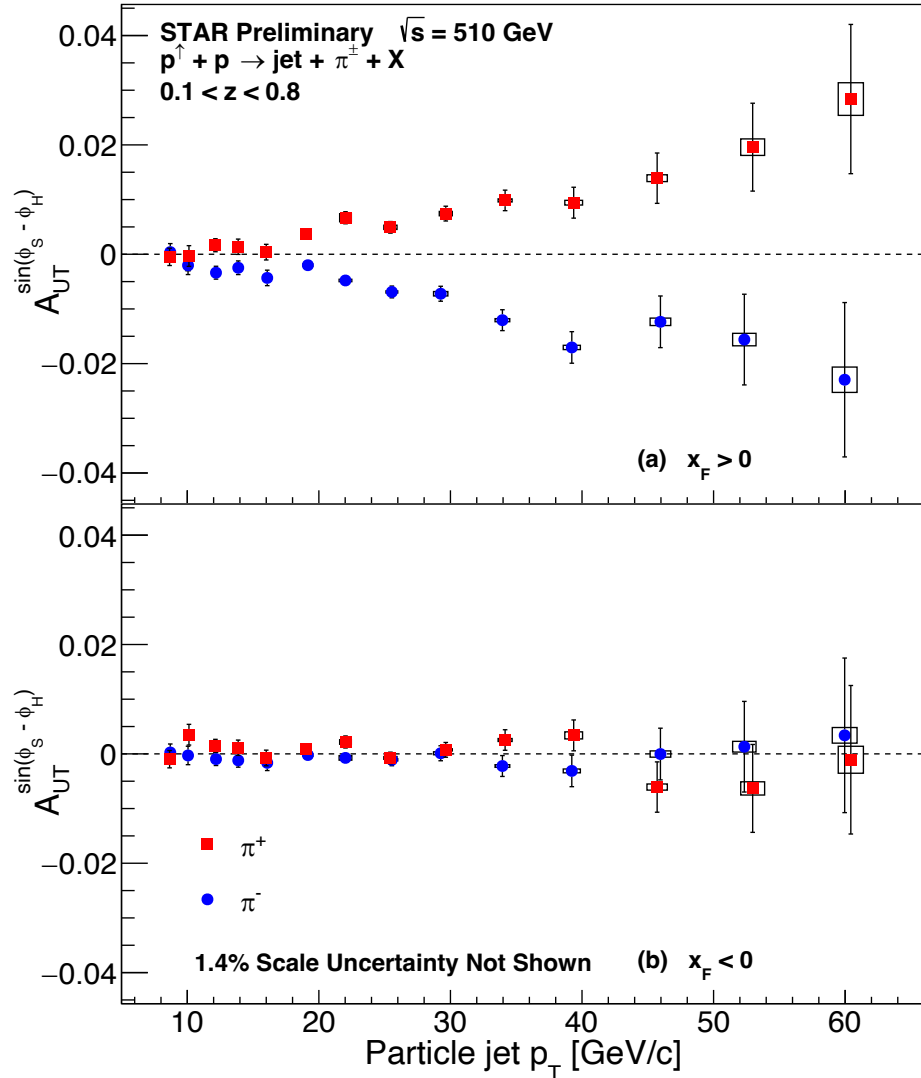

- New results are consistent with previous run11 data, but with 14 times more statistics

Collins Asymmetry of pion at 510/200 GeV: Test the TMD Evolution



➤ As a function of jet- x_T

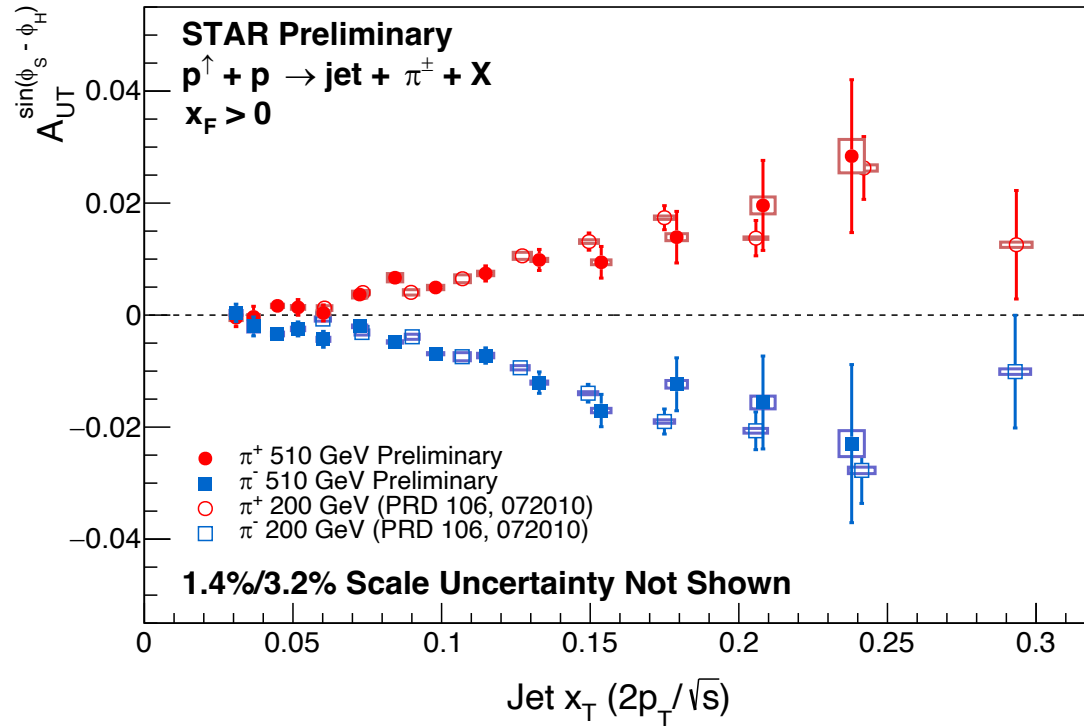

- The high precision Collins results of 510 GeV and 200 GeV nicely align with jet x_T & hadron j_T scale, giving almost no energy dependence.
- These data provide important constraints on the scale evolution for Collins asymmetry.

➤ As a function of hadron j_T

j_T : pion's transverse momentum relative to jet axis

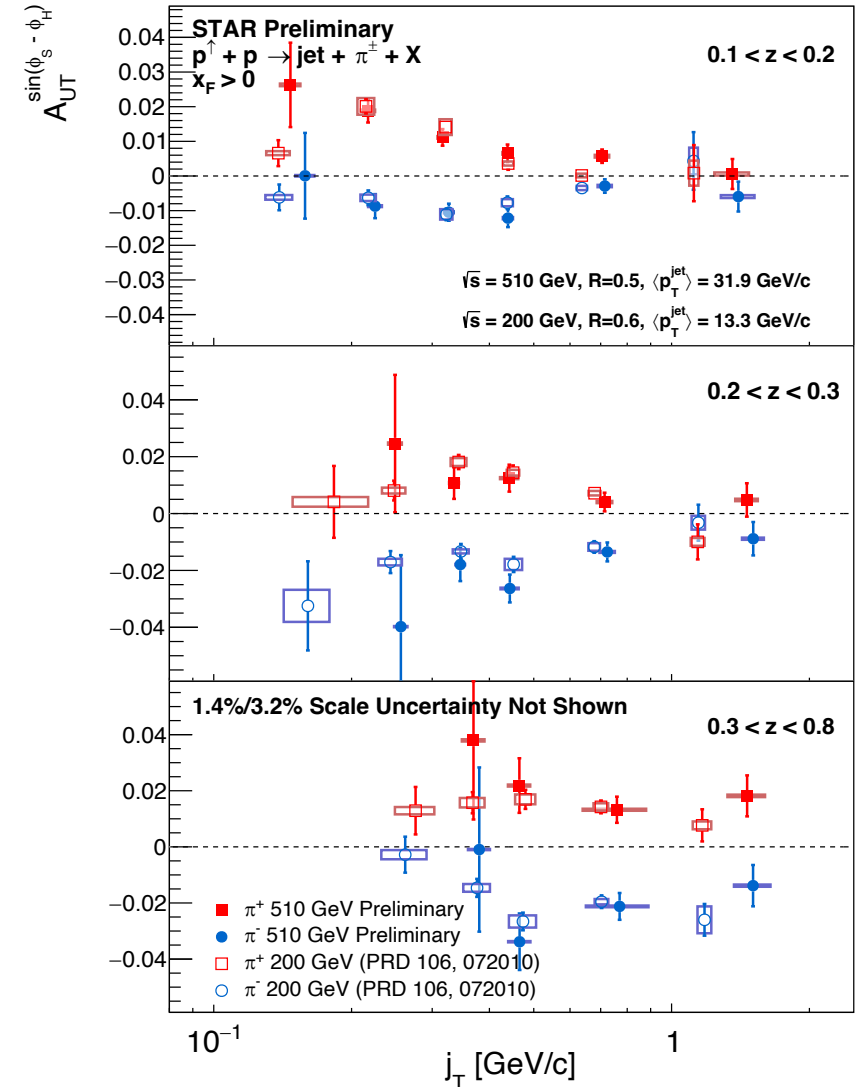

Comparison to Theoretical Calculations

- 500/510 GeV, as a function of z
 z : pion's longitudinal momentum fraction in jet

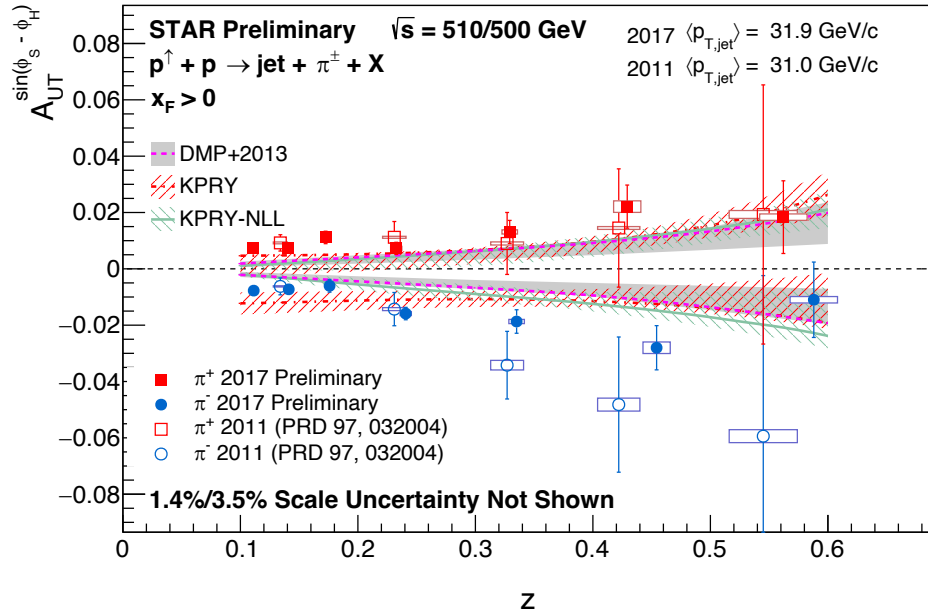

U. D'Alesio, F. Murgia and C. Pisano, Phys. Lett. B 773 (2017), 300-306
Z. B. Kang, A. Prokudin, F. Ringer and F. Yuan, Phys. Lett. B 774 (2017)

- Experimental results and theories are in agreement, but model calculations undershoot the observed asymmetries.
- DMP+2013 and KPRY apply the collinear QCD evolution, assume universality and factorization
- KPRY model also apply TMD evolution beyond collinear assumption

- 200 GeV, as a function of j_T
 j_T : pion's transverse momentum relative to jet axis

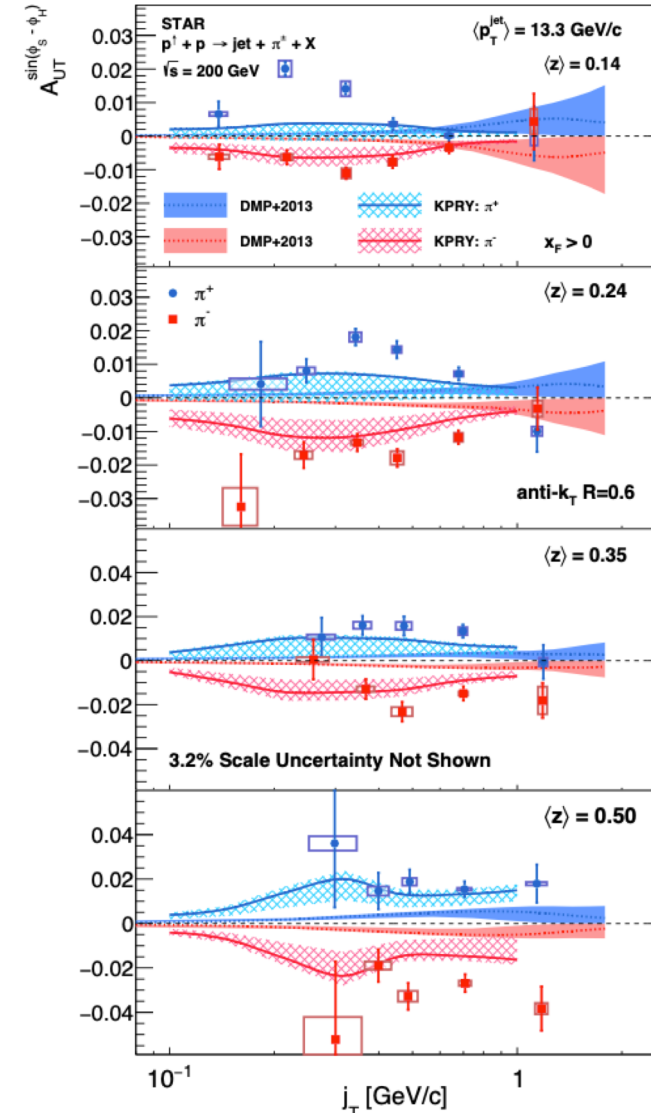

STAR, Phys. Rev. D 106, 072010 (2022)

Collins Asymmetry of K & p

STAR, Phys. Rev. D 106, 072010 (2022)

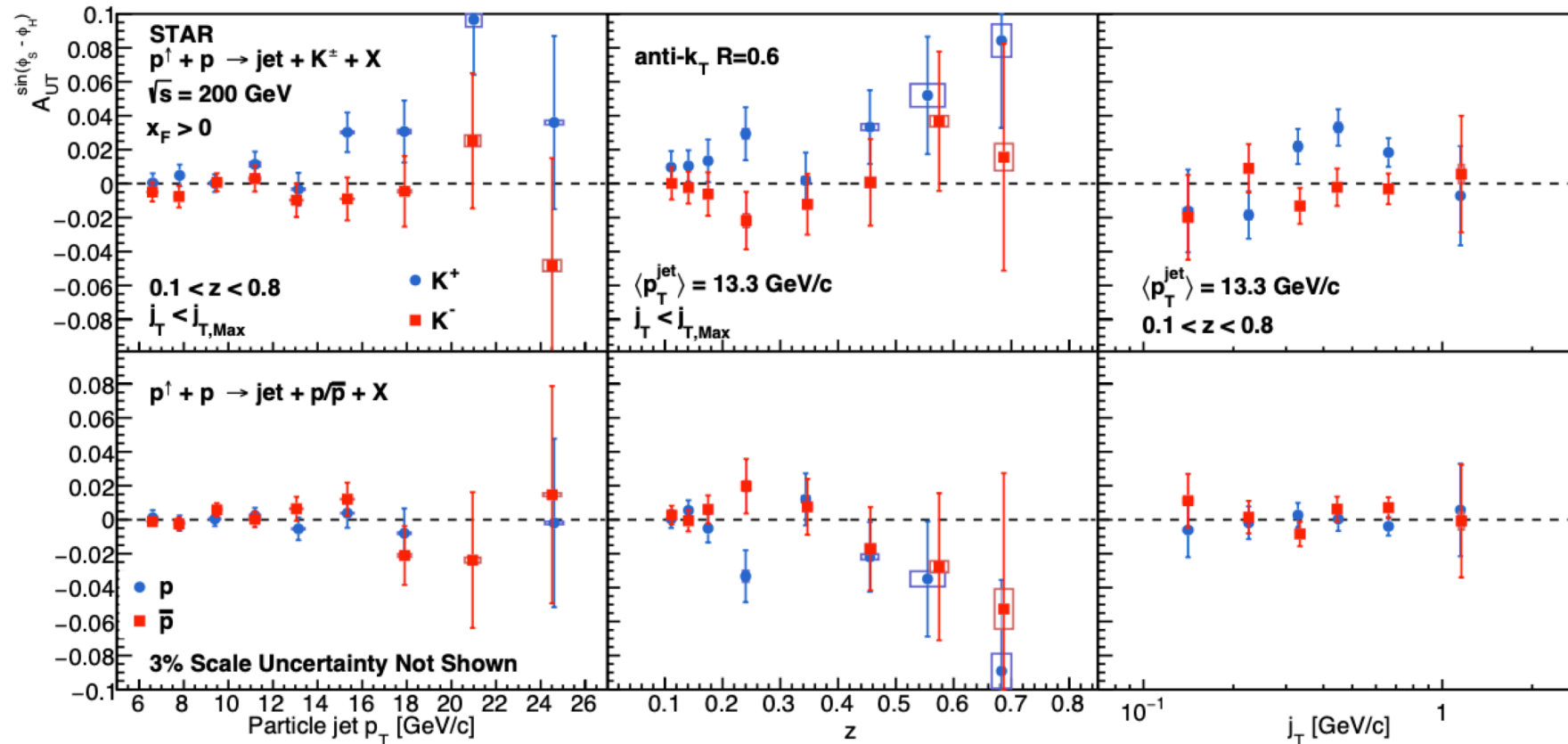

- The results for K^+ have a contribution from favored fragmentation of u quarks, are similar in magnitude to those for π^+
- While the results for K^- can only come from unfavored fragmentation, are consistent with zero within uncertainties
- Fragmentation into protons is not expected to produce Collins asymmetries.

Collins-like Asymmetry of pion

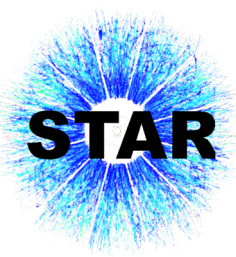

➤ 200GeV, as a function of z

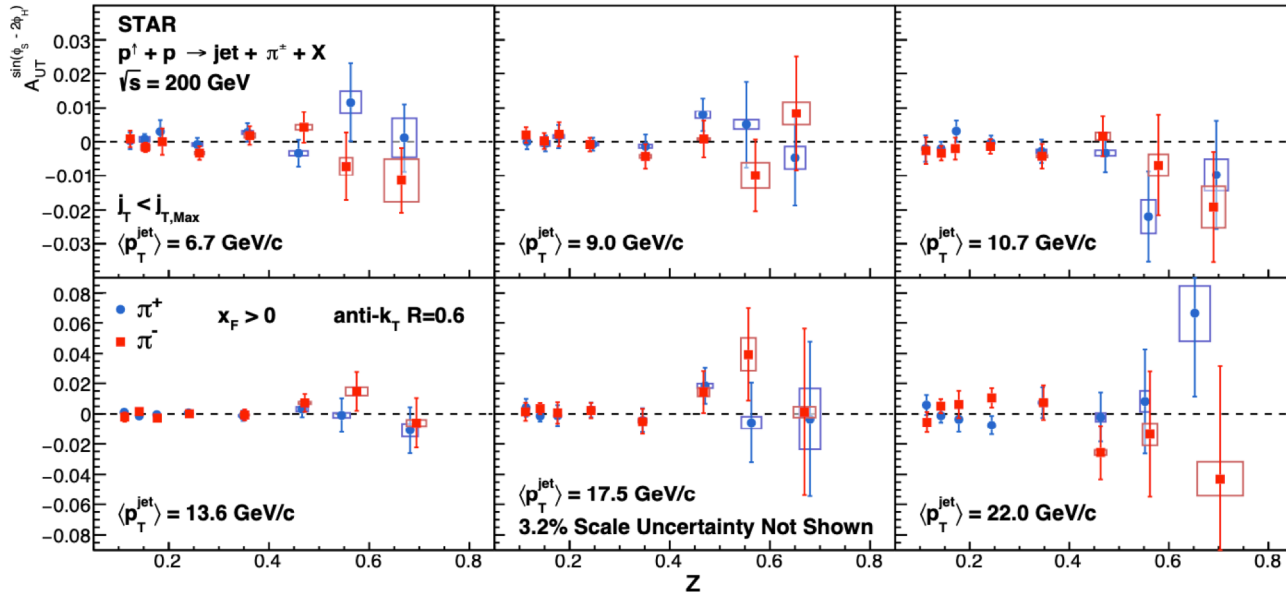

STAR, Phys. Rev. D 106, 072010 (2022)

- Sensitive to gluon linear polarization coupled to the “Collins-like” fragmentation function
- No significant asymmetry for either collision energy

➤ 500GeV, as a function of z

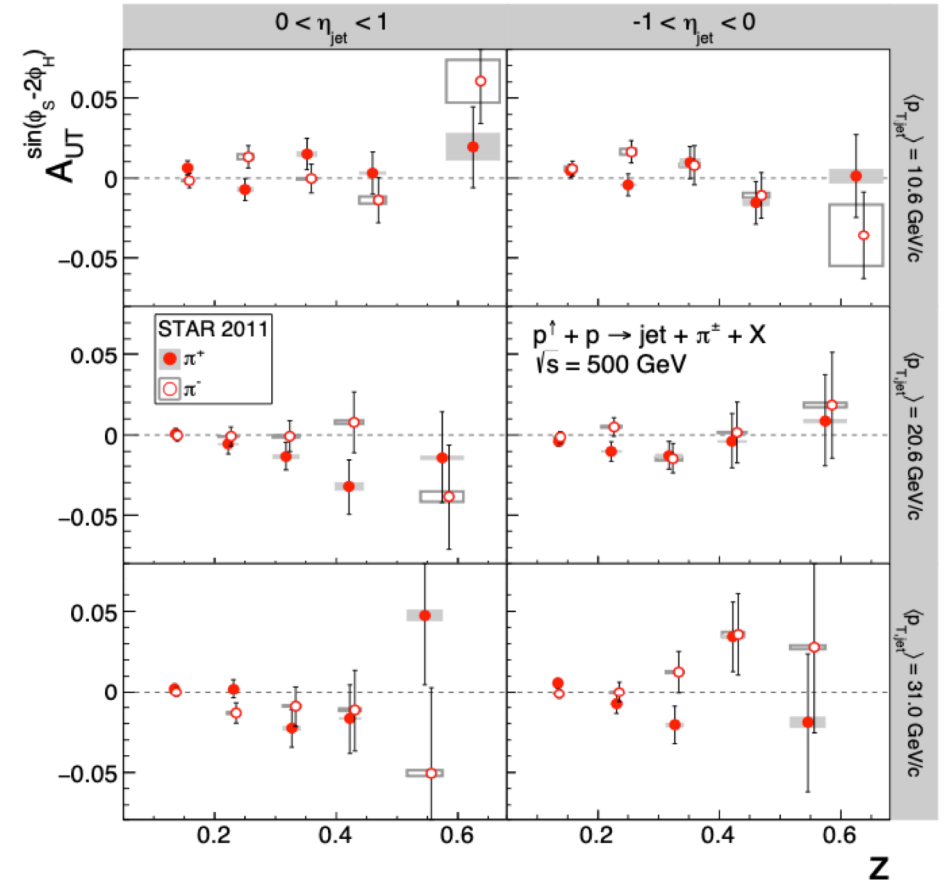

STAR, Phys. Rev. D 97, 032004 (2018),

Summary & Outlook

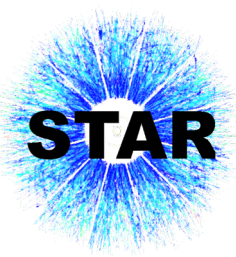

- New preliminary results on transverse single-spin asymmetries of jets and π^\pm within-jets in pp at $\sqrt{s} = 510$ GeV with STAR 2017 data
- The high precision Collins asymmetries for π^+ and π^- results at 510 GeV, in excellent consistency with 200 GeV data, no energy dependence observed.
- No significant Sivers asymmetry or Collins-like asymmetry observed in pp collision.
- A large data sample of transverse polarized pp data taken in 2022 at STAR ($\sim 400 pb^{-1}$), with the forward detectors ($2.5 < \eta < 4$) installed, provides a unique opportunity to study Collins and Sivers effect in the forward region.

Back up

Collins Asymmetry from STAR 2017 Data

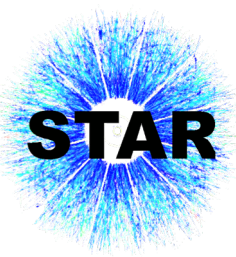

➤ Collins results as a function of z in different jet p_T regions at 510 GeV:

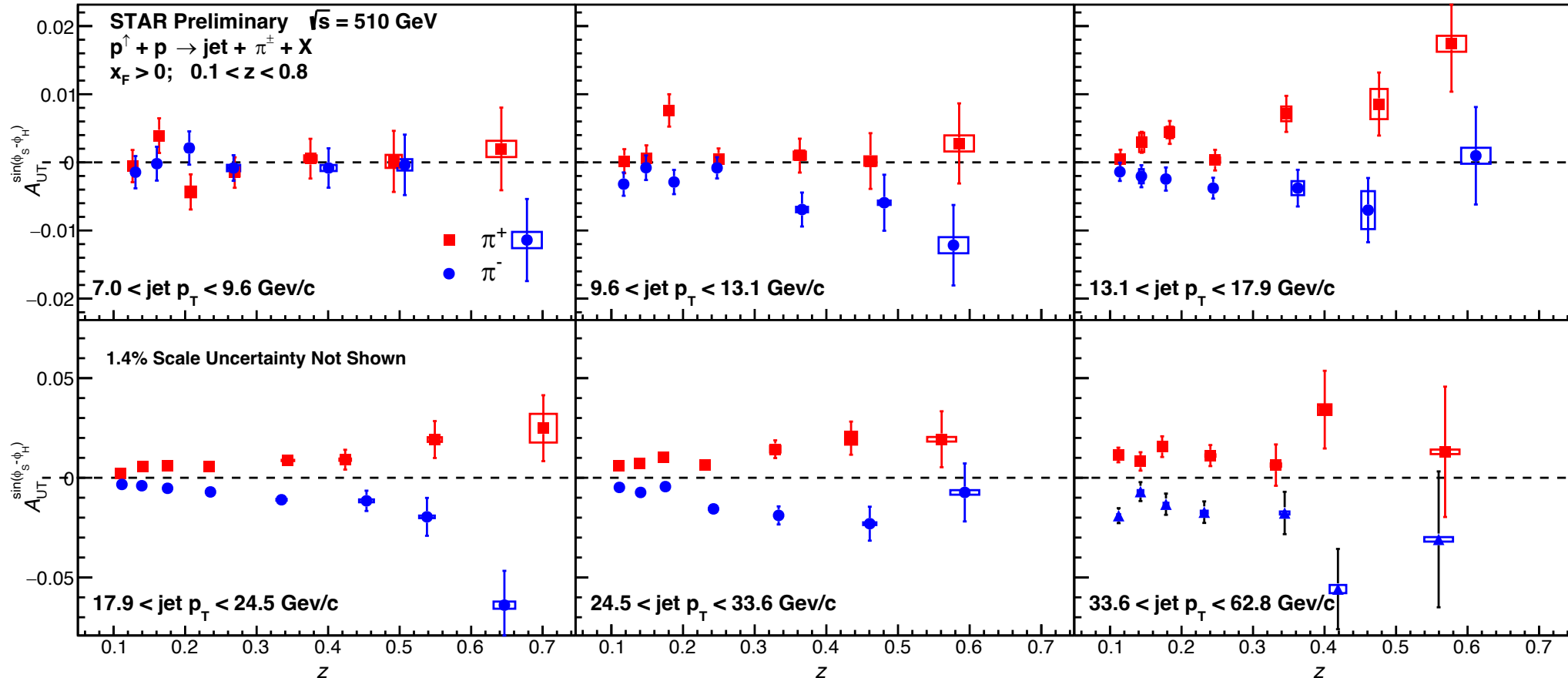

z : the pion's longitudinal momentum fraction in the jet

- These results provide more detailed constraints on the Collins fragmentation function

Collins Asymmetry from STAR 2017 Data

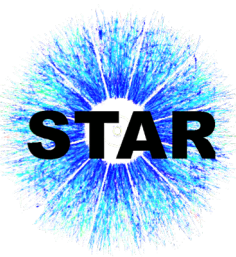

➤ Collins results as a function of j_T in different jet p_T regions at 510 GeV:

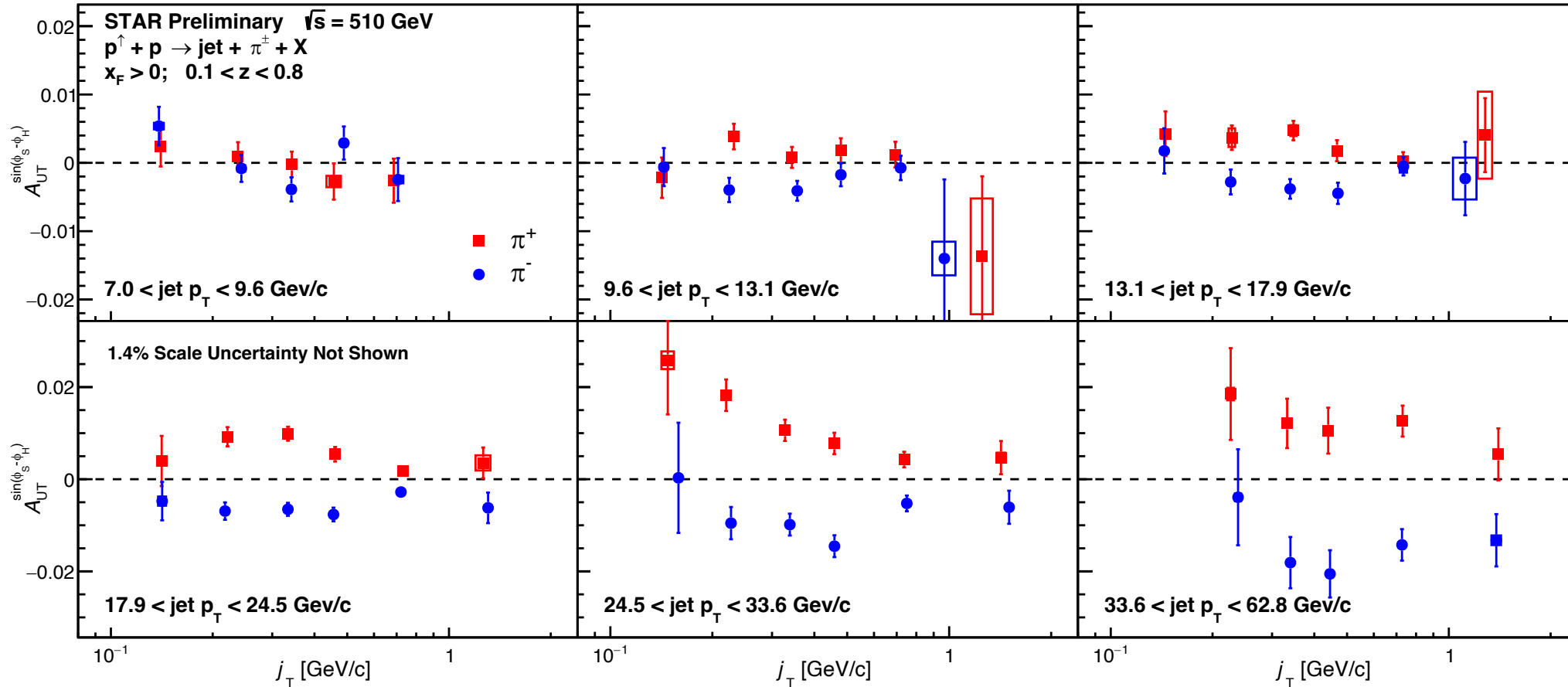

j_T : charged pion's transverse momentum relative to the jet axis

- These results provide more detailed constraints on the Collins fragmentation function

➤ Recent Collins results Highlighted in the “2023 Long Range Plan for Nuclear Science”

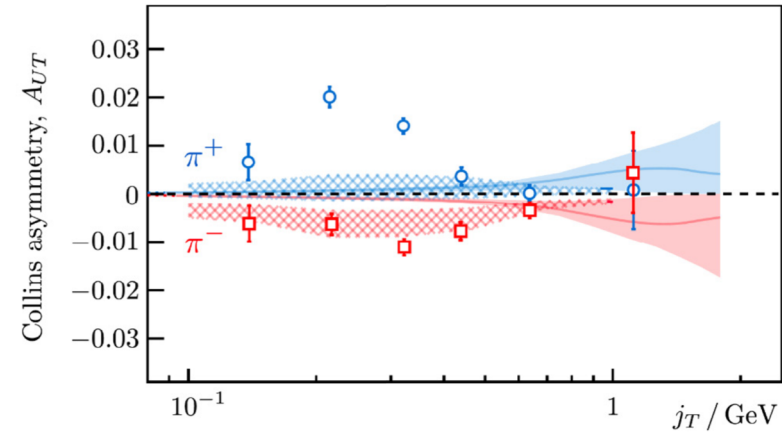

M. Abdallah et al. [STAR], Phys. Rev. D 106, no.7, 072010 (2022)

- Significantly larger than the theoretical predictions
- Providing new insight on spin–momentum correlations, challenging some contemporary theoretical models