

High performance sensor interfaces: Efficient system architectures and calibration techniques

Marc Pastre – 2011



Outline

- Sensor interfaces
 - System architectures
 - Open-loop vs. Closed-loop
 - Continuous-time vs. Sampled
 - Frontends
 - Voltage-, current-, charge-mode
- Case studies
 - Hall sensor
 - MEMS-based accelerometer
- Digital calibration
 - Successive approximations
 - M/2^M Sub-binary DACs for successive approximations
- Conclusion

Open-loop vs. Closed-loop

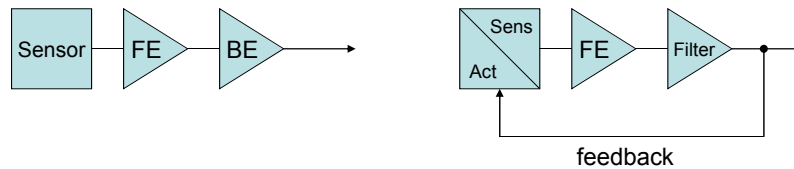

- Straightforward implementation
- Analog output
- Sensitive to sensor non-linearity
- Directly compatible with a $\Delta\Sigma$ loop
- Digital or analog output
- Insensitive to sensor non-linearity
- Sensitive to actuator non-linearity
- Feedback loop stability
- Bandwidth

Continuous-time vs. Sampled systems

- Continuous-time:
 - Straightforward
 - Low power consumption
 - High bandwidth
 - Not really compatible with continuous-time calibration
- Sampled systems directly compatible with:
 - Closed-loop $\Delta\Sigma$ modulators
 - Switched capacitor circuits
 - Digital calibration

Voltage-, current-, charge-mode

- Voltage-mode:
 - Hi-Z \Rightarrow Instrumentation amplifier, Op-Amp (+ input)
 - Low-Z \Rightarrow Op-Amp circuit, switched capacitor
- Current-mode:
 - Transimpedance amplifier
(based on common-source transistor, Op-Amp, ...)
 - Switched capacitor circuit used as integrator
 - Virtual ground @ input
- Charge-mode:
 - Transimpedance integrator
(based on common-source transistor, Op-Amp, ...)
 - Switched capacitor

Case studies

- Hall sensor microsystem:
 - Open-loop
 - Voltage-mode
 - Sampled
 - Continuous-time sensitivity calibration
- MEMS-based accelerometer:
 - Closed-loop
 - Voltage-/Charge-mode
 - Sampled
 - Sensor included in a $\Delta\Sigma$ loop

Hall sensor microsystem

- Continuous-time sensitivity calibration
- Reference field generated by integrated coil
- Combined modulation scheme mixes up reference and external signal
- Parallel demodulation schemes allow continuous background sensitivity calibration
- Compensation of any cause of drift (temperature, mechanical stresses, ageing)

Sensitivity drift of Hall sensors

- Drift due to
 - Temperature
 - Mechanical stresses
 - Ageing
- Typical temperature drift
 - 500 ppm/°C uncalibrated
 - 300 ppm/°C with 1st order correction
- Typical ageing drift
 - 20'000 ppm (2 %)

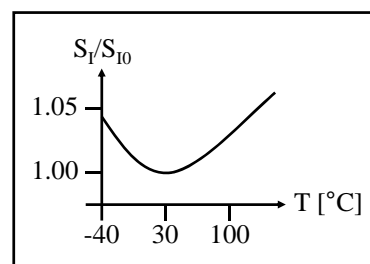

System architecture

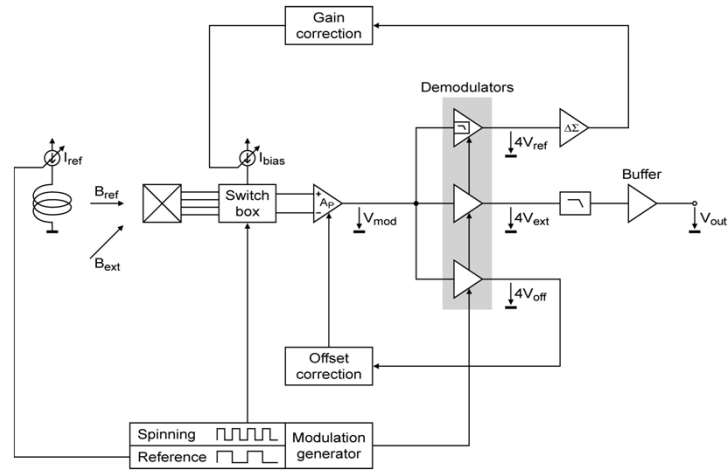

Spinning current modulation

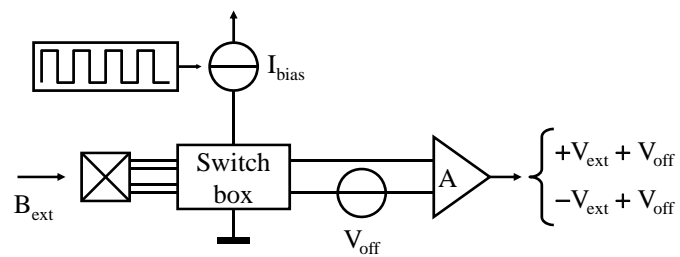

- 2 modulation phases
- Modulated signal, constant offset
- Offset-free signal extracted by demodulation

Combined modulation

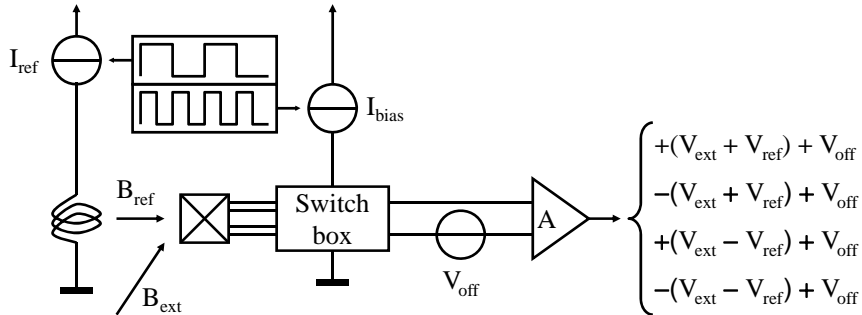

- 4 modulation phases
- Modulated signal & reference, constant offset
- Modulation frequency of 1 MHz

Demodulation schemes

Phase	Modulation		Amplifier output	Demodulation		
	Spin.	Coil		Sig.	Ref.	Off.
1	+	+	$+(V_{\text{ext}} + V_{\text{ref}}) + V_{\text{off}}$	+	+	+
2	-	+	$-(V_{\text{ext}} + V_{\text{ref}}) + V_{\text{off}}$	-	-	+
3	+	-	$+(V_{\text{ext}} - V_{\text{ref}}) + V_{\text{off}}$	+	-	+
4	-	-	$-(V_{\text{ext}} - V_{\text{ref}}) + V_{\text{off}}$	-	+	+
				$4V_{\text{ext}}$	$4V_{\text{ref}}$	$4V_{\text{off}}$

- 3 different demodulation schemes
- Offset-free signal & reference demodulation, using synchronous switched-capacitor circuits

Reference signal demodulation

- 2 limitations for precise reference signal extraction:
 - Low reference signal level
 - $V_{\text{Hall,ref}} = (S_{\text{I,Hall}} \cdot I_{\text{bias}}) \cdot (E_{\text{I,coil}} \cdot I_{\text{ref}}) = 40 \mu\text{V}$
 - $V_{\text{Hall,ref}} \cdot 0.1\% = 40 \text{ nV}$
 - Input-referred noise = 20 nV/ $\sqrt{\text{Hz}}$ @ 1 MHz
 - External signal aliasing
 - $V_{\text{ext,max}} = 100 \cdot V_{\text{ref}}$
 - High-pass parasitic transfer function
- Solution: Reference signal filtering

Reference signal filtering

- Filtering combined with reference signal demodulation and analog-to-digital conversion
- Second-order low-pass filtering
- Demodulator pole @ 1 kHz
 - Feedback path in the switched-capacitor demodulator
- Delta-sigma pole @ 0.1 Hz
 - Long integration period

Filtering transfer function

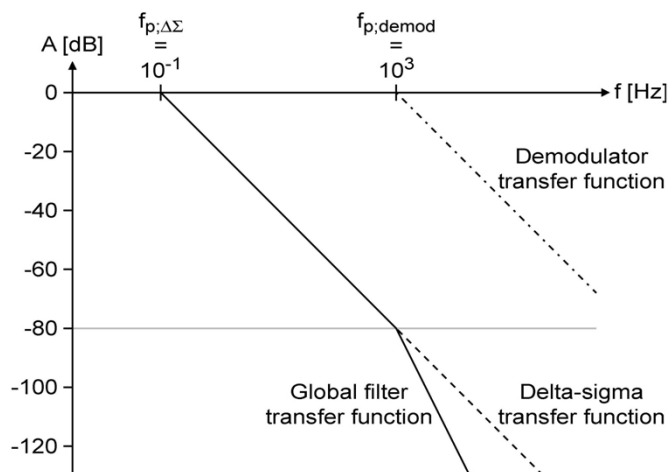

External signal aliasing

$$\begin{aligned}
 &+[(V_{\text{ext};1} + V_{\text{ref}}) + V_{\text{off}}] \\
 &-[-(V_{\text{ext};2} + V_{\text{ref}}) + V_{\text{off}}] \\
 &-[(V_{\text{ext};3} - V_{\text{ref}}) + V_{\text{off}}] \\
 &+[-(V_{\text{ext};4} - V_{\text{ref}}) + V_{\text{off}}] = 4V_{\text{ref}} + \underbrace{[(V_{\text{ext};1} + V_{\text{ext};2}) - (V_{\text{ext};3} + V_{\text{ext};4})]}_{\text{Parasitic term}}
 \end{aligned}$$

- Variation of the external signal between the reference demodulation phases \Rightarrow alias
- Derivative effect \Rightarrow high-pass transfer function
- Zero @ 100 kHz

Effect of filtering on alias

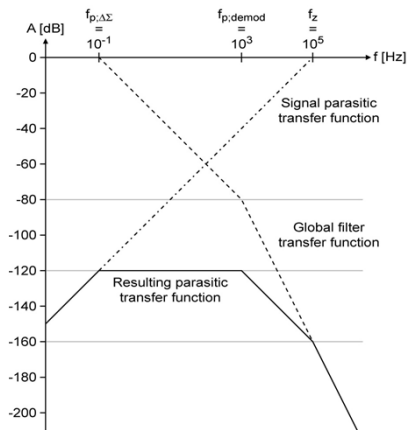

- Minimum attenuation of 120 dB

Effects of filtering

- On noise
 - Bandwidth limited to less than 1 Hz
 - White noise integrated in limited bandwidth
 - Total input-referred RMS noise $< V_{\text{Hall,ref}} \cdot 0.1\% = 40 \text{ nV}$
- On aliased external component
 - Minimum attenuation of 120 dB
 - $V_{\text{ext,max}} = 100 \cdot V_{\text{ref}}$ attenuated to $100 \cdot V_{\text{ref}} / 10^6 = V_{\text{ref}} \cdot 0.01\%$
- Extraction of $V_{\text{ref}} \cdot 0.1\%$ possible \Rightarrow sensitivity calibration with 1'000 ppm accuracy

Sensitivity drift compensation

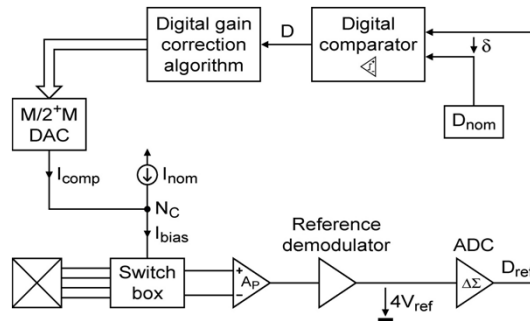

- Sensitivity compensated by sensor bias current adjustment
- $V_{Hall} = (S_{I;Hall} \cdot I_{bias}) \cdot B$

Offset compensation

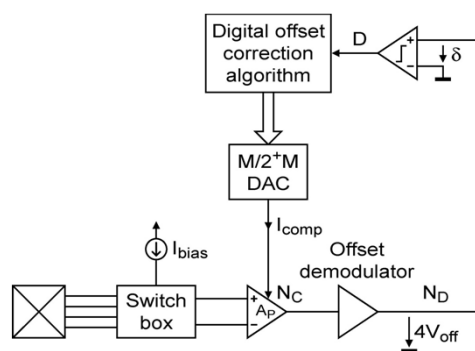

- Compensation current injection into preamplifier
- Demodulator can be optimized (low-pass filter)

Circuit micrograph

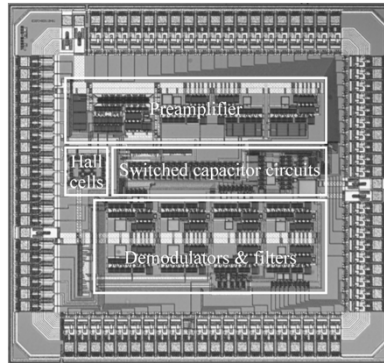

- 11.5 mm² in AMS 0.8 μ m CXQ
- Hall sensors & coils integrated

Measurement results

Supply voltage	5 V
Sensitivity	35 V/T
Full scale	± 50 mT
Bandwidth	500 kHz
Non-linearity	< 0.1 %
Gain drift	< 50 ppm/ $^{\circ}$ C

- Compared to state of the art:
 - High bandwidth
 - Low gain drift (6-10 times better)

MEMS-based accelerometer

- Closed-loop system
- 5th order $\Delta\Sigma$ loop: Sensor (2nd order) + Filter (3rd order)
- Low-precision front-end (7 bits)
- Internally non-linear ADC
- Digital filter (3rd order)
- Versatile and reconfigurable system, yet featuring high performances

System architecture

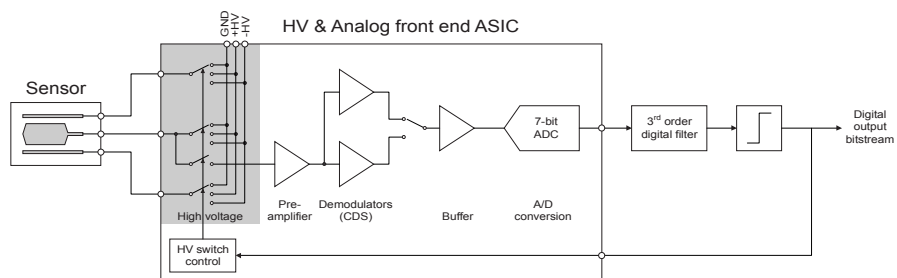

Frontend

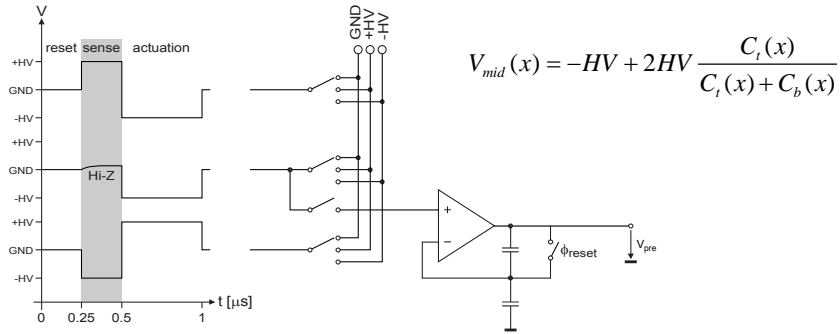

- 11.5 mm² in AMS 0.8 μm CXQ
- Hall sensors & coils integrated

Time-interleaved CDS

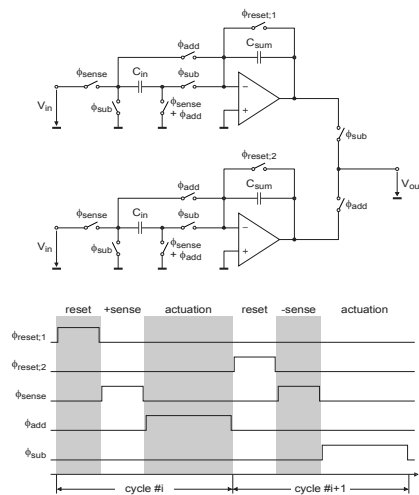

Internally non-linear ADC

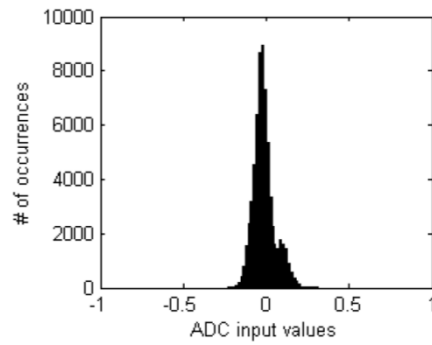

Circuit micrograph

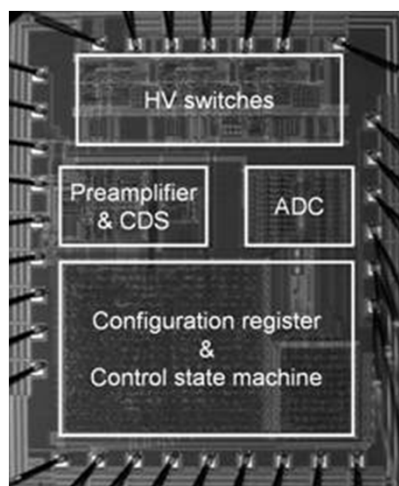

Measurement results

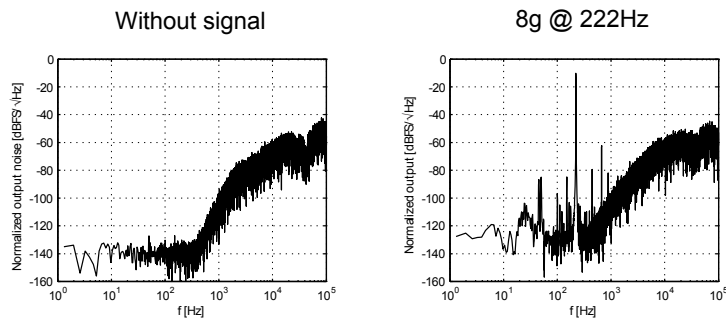

- Compared to state of the art:
 - High bandwidth
 - Low gain drift (6-10 times better)

Measurement results

Supply voltage	3.3V / ± 9V
Sampling frequency	1 MHz
$\Delta\Sigma$ loop order	2 + 3 = 5
Full scale	11.7 g
Bandwidth	300 Hz
Input noise	1.7 $\mu\text{g}/\sqrt{\text{Hz}}$
Dynamic range (300 Hz)	19 bits
SNR (300 Hz)	16 bits

Digital calibration

- Digital compensation of analog circuits
- Successive approximations:
 - Algorithm
 - Working condition
- Sub-binary DACs for successive approximations:
 - Resolution
 - Radix
 - Tolerance to component mismatch
 - Architectures
 - Design

Digital compensation

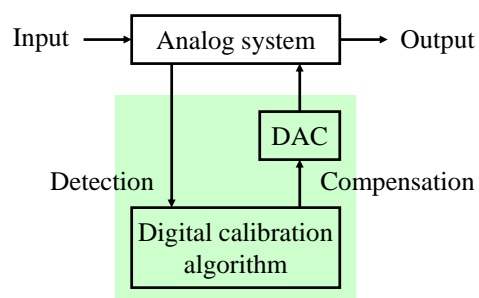

- High-precision calibration of low-precision circuits
- Alternative to intrinsically precise circuits (matching & high area)

Compensation methodology

- Detection configuration
 - Continuous: normal operation configuration
 - Interrupted: special configuration
- Detection node(s)
 - Imperfection sensing
 - Usually voltage-mode
- Compensation node(s)
 - Imperfection correction
 - Current-mode

Offset cancellation in OAs

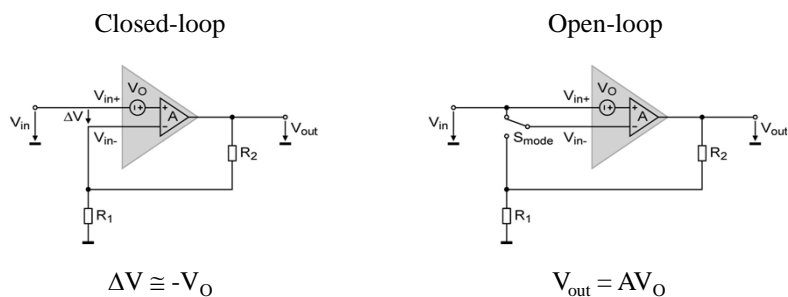

- Closed-loop: calibration during operation possible
- Open-loop: higher detection level

Offset compensation in OAs

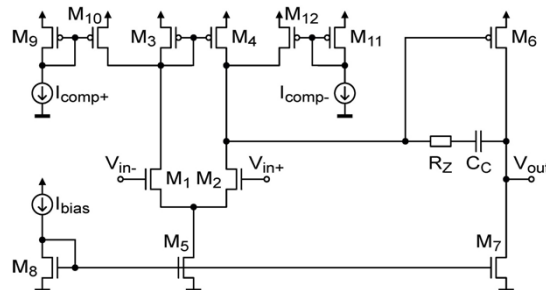

- Compensation by current injection
- Unilateral/bilateral
- Compensation current sources: $M/2+M$ DACs

Choice of compensation node(s)

- Compensation current corrects imperfection only
- Current injected by a small current mirror, taking into account:
 - Channel length modulation
 - Saturation voltage
- Connection of the current mirror does not affect the compensation node characteristics:
 - Impedance
 - Parasitic capacitance
 - System parameters linked to parasitics

Offset distribution before compensation

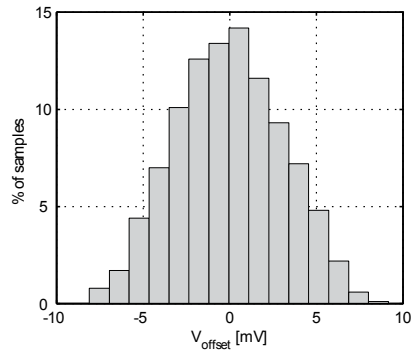

- Gaussian distribution
- Depends on component matching

Offset reduction

- Offset can be reduced by:
 - Matching \Rightarrow Increase area
 - Digital calibration
- Digital calibration circuits can be made very small
- In deep sub-micron technologies:
 - Design analog circuits with reasonable performance
 - Enhance critical parameters by digital calibration
- Mixed-signal solution is optimal in terms of global circuit area

Offset distribution after digital compensation

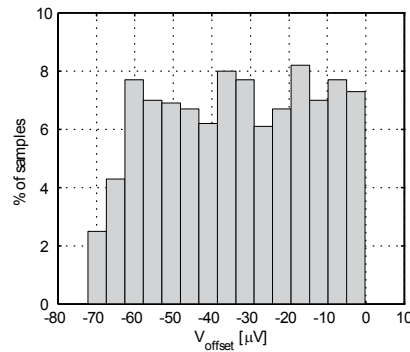

- Uniform distribution (in a 1 LSB interval)
- Residual offset depends on DAC resolution

Successive approximations

```
reset all di = 0
for i = n downto 1
  set di = 1
  if Cout > 0
    reset di = 0
  end if
end for
```

- The algorithm decides on the basis of comparisons
- A comparator senses the sign of the imperfection
- Working condition: $b_i \leq b_1 + \sum_{j=1}^{i-1} b_j$ ($i \in [2, n]$)

Offset compensation: Target

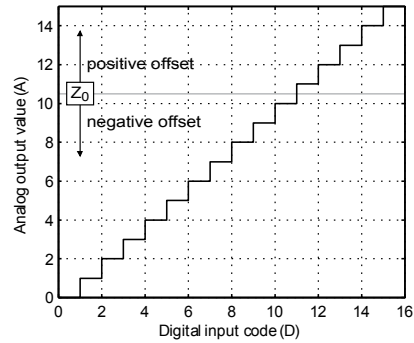
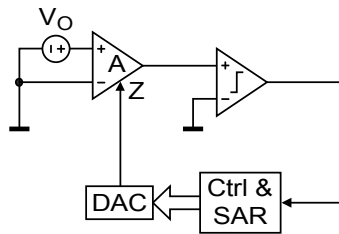

- Z_0 : Correction value that perfectly cancels the offset
- $A < Z_0$: Resulting offset negative
- $A > Z_0$: Resulting offset positive

Offset compensation: Algorithm execution

```

reset all  $d_i = 0$ 
for  $i = n$  downto 1
  set  $d_i = 1$ 
  if  $C_{out} > 0$ 
    reset  $d_i = 0$ 
  end if
end for
    
```

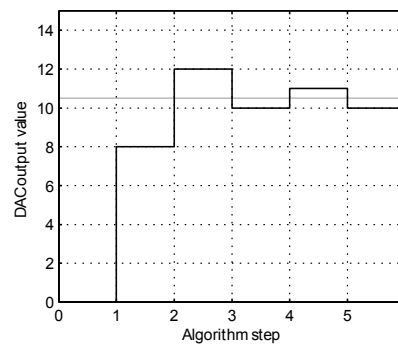

- From MSB to LSB
- Bit kept if compensation value insufficient

DAC Resolution

$$Resolution = \frac{FullScale}{LSB} \leq \frac{V_{offset;uncompensated;max}}{V_{offset;compensated;max}}$$

- Full scale chosen to cover whole uncompensated offset range
- Resolution corresponds to residual offset achieved after compensation

DACs for successive approximations

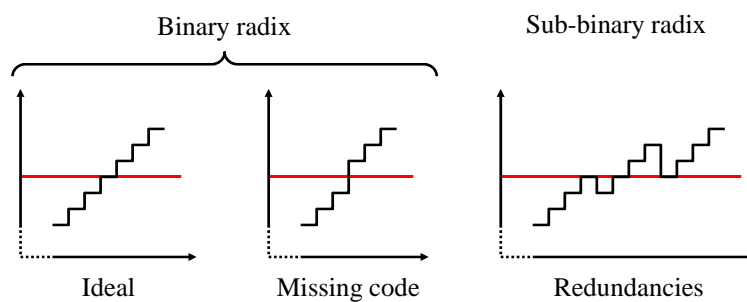

- Imperfections in DACs for compensation
 - Missing codes are problematic
 - Redundancies are acceptable

Sub-binary radix DACs

- Code redundancies are voluntarily introduced to:
 - Account for variations of component values
 - Avoid missing codes
- Arbitrarily high resolutions can be achieved without exponential increase of area
- For successive approximations:
 - Precision is not important
 - Resolution is the objective
- **Sub-binary DACs are ideal in conjunction with successive approximations**
 - **Very low area**

Sub-binary DACs: Radix

Radix = 1.5

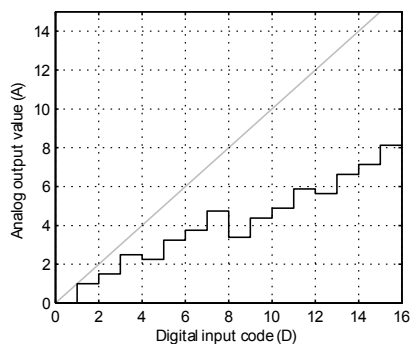

Radix = 1.75

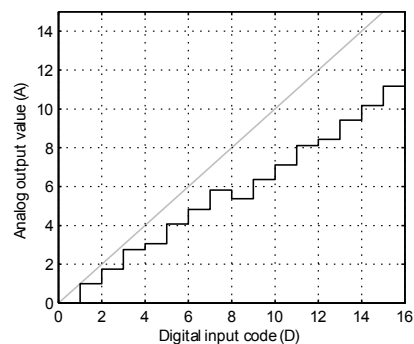

Radix: Tolerance to component mismatch

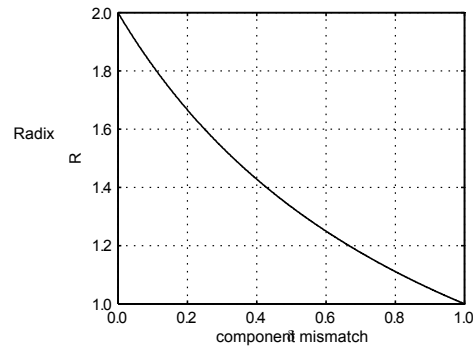

- Radix-2 tolerates no mismatch!
- 100 % mismatch \Rightarrow thermometric DAC (radix-1)

Implementation: Current-mode R/2R converters

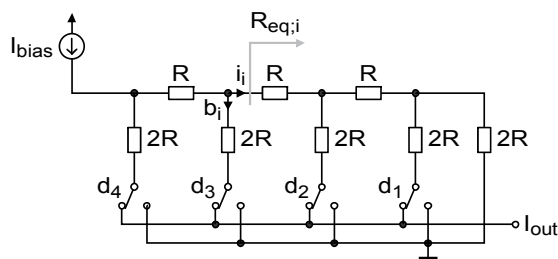

$$b_i = b_1 + \sum_{j=1}^{i-1} b_j$$

- $R_{eq,i} = 2R (\forall i)$
- Current divided equally in each branch ($i_i = b_i$)
- Component imperfection \Rightarrow current imbalance \Rightarrow missing code (or redundancy)

R/2⁺R converters

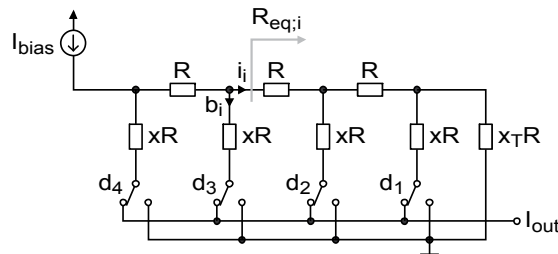

$$b_i < b_1 + \sum_{j=1}^{i-1} b_j$$

- $x > 2$; $R_{eq,i} < xR$; $i_i > b_i$
- Current division voluntarily unbalanced
 - Radix < 2 (sub-binary)
 - Code redundancies

R/2⁺R converters: Pseudo-MOS implementation

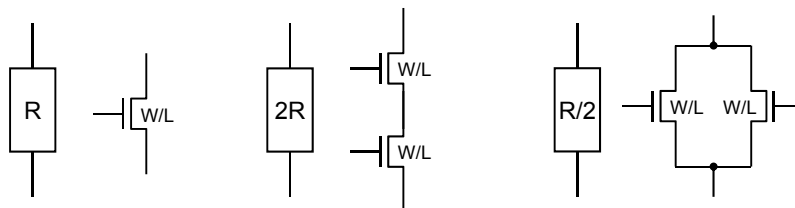

- Resistors can advantageously be replaced by transistors to implement the current division
- Unit-size device with fixed W/L implements R
- Unit-size devices are put in series (2R) or in parallel (R/2)
- Unit-size transistors are kept very small
- Condition: V_G identical for all transistors

M/3M converters

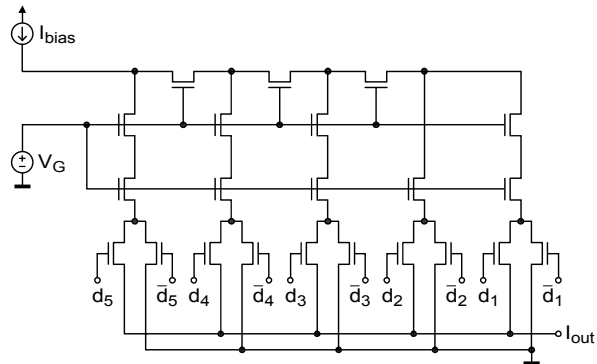

- Radix 1.77 ; maximum mismatch 13 %
- $V_G = V_{DD}$ allows driving d_i directly with logic

M/2.5M converters

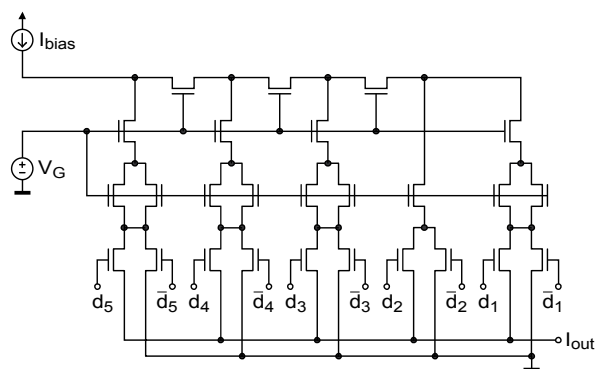

- Radix 1.86 ; maximum mismatch 7.3 %
- $V_G = V_{DD}$ allows driving d_i directly with logic

Current collectors & Output stage

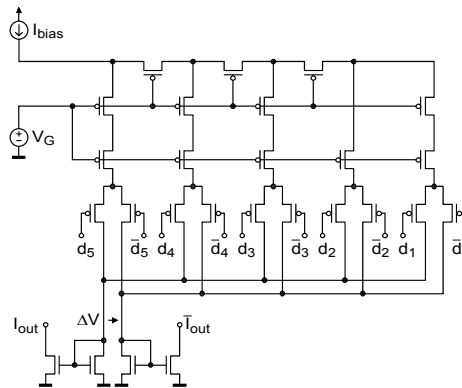

- Current mirrors simple to implement
- ΔV is not problematic

Conclusion

- Closed-loop systems are less sensitive to imperfections
- Calibration can be included transparently in sampled systems
- It is advantageous to include sensors in $\Delta\Sigma$ loops
- Switched capacitor circuits enable flexible and reconfigurable systems
- Calibration is necessary in deep sub-micron technologies to reach high performances
- Improve analog performance with digital calibration:
 - Design analog circuits with reasonable performance
 - Enhance critical parameters by digital calibration
 - Mixed-signal solution optimal in terms of global circuit area

References

- M. Pastre, M. Kayal, H. Blanchard, "A Hall Sensor Analog Front End for Current Measurement with Continuous Gain Calibration", IEEE Sensors Journal, Special Edition on Intelligent Sensors, Vol. 7, Number 5, pp. 860-867, May 2007
- M. Pastre, M. Kayal, H. Schmid, A. Huber, P. Zwahlen, A.-M. Nguyen, Y. Dong, "A 300Hz 19b DR capacitive accelerometer based on a versatile front end in a 5th order $\Delta\Sigma$ loop", IEEE European Solid-State Circuits Conference (ESSCIRC), pp. 288-291, September 2009
- M. Pastre, M. Kayal, "Methodology for the Digital Calibration of Analog Circuits and Systems – with Case Studies", Springer, The International Series in Engineering and Computer Science, Vol. 870, ISBN 1-4020-4252-3, 2006
- M. Pastre, M. Kayal, "Methodology for the Digital Calibration of Analog Circuits and Systems Using Sub-binary Radix DACs", IEEE Mixed Design of Integrated Circuits and Systems Conference (MIXDES), June 2009
- M. Pastre, M. Kayal, "High-precision DAC based on a self calibrated sub-binary radix converter", IEEE International Symposium on Circuits and Systems (ISCAS), Vol. 1, pp. 341-344, May 2004
- C. C. Enz, G. C. Temes, "Circuit Techniques for Reducing the Effects of Op-Amp Imperfections: Autozeroing, Correlated Double Sampling, and Chopper Stabilization", Proceedings of the IEEE, Vol. 84, pp. 1584-1614, November 1996