

# SNS for Muon Collider Proton Driver R&D

Presented at the

WP3 Proton Complex Meeting #10

Nicholas Evans

Friday, June 23, 2023

ORNL is managed by UT-Battelle, LLC for the US Department of Energy

# Muon Collider Proton Driver

- First stage of MC is a high power, short pulse proton beam for secondary production – not the biggest challenge, but still a challenge!
- Proposals call for a high-energy linac + rings in some combination
- SNS resembles some conceptions of a proton driver – SC linac + Accumulator

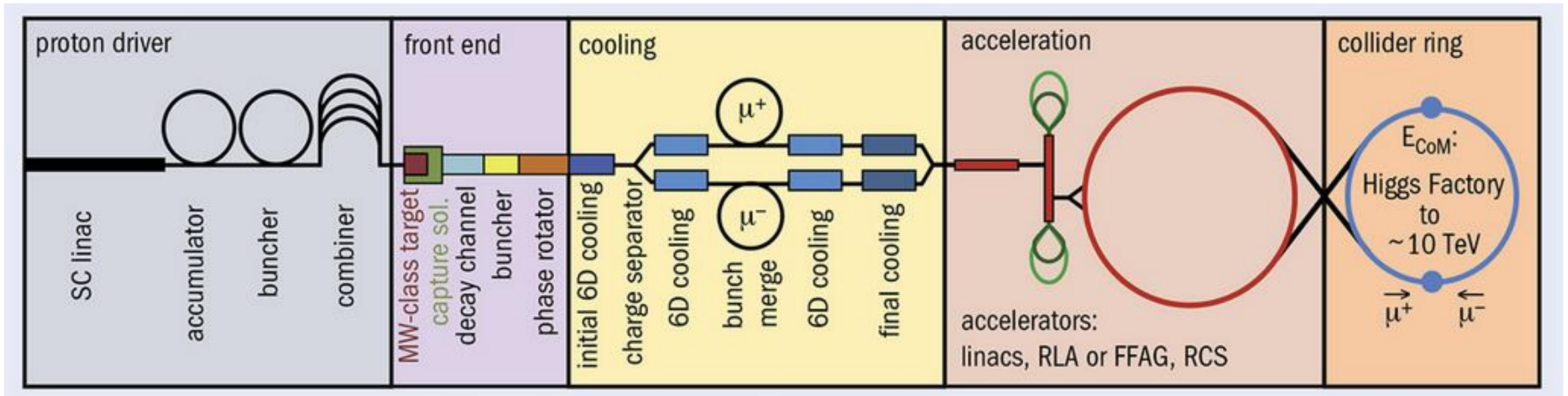

We can study beam physics at SNS near MAP requirements for a proton driver with accumulator/buncher combined addressing most of the identified technical challenges in MAP and March 2023 IMCC report.

# Proton Driver Challenges: Where SNS fits in

Accettura et al. [arXiv:2303.08533v1](https://arxiv.org/abs/2303.08533v1)

## 3.2.1 Technical issues and required R&D

The technology choice for the MuC proton driver relies on successfully managing the heat deposition in the injection foil in the accumulator ring, limits on beam intensity due to space charge and the successful compression of the proton bunch. The MuC uses a beam that has a higher intensity at lower repetition rate than comparable machines, resulting in a space-charge dominated facility. At higher energy space charge limitations may be relaxed, but care must be taken to avoid uncontrolled stripping of the H<sup>-</sup> beam and excessive heat deposition that can damage the foil.

We're actively addressing these issues.

Post-upgrade SNS charge per pulse satisfies a 10 Hz, 8 GeV requirements (albeit at lower energy)

Because of scaling, space charge regime is probably reachable.

Table 2: Typical proton source parameters. The parameters are indicative.

Parameter	Unit	Target value
Beam power	MW	2-4
Energy	GeV	5-30
Repetition Rate	Hz	5-10
RMS bunch length	ns	1-3

Accettura et al. [arXiv:2303.08533v1](https://arxiv.org/abs/2303.08533v1)

Boscolo et al. Rev. of Acc. Sci. and Tech, vol. 10, 2019

injection into pre-existing RF buckets. The second storage ring (the Compressor) accepts two to four bunches from the Accumulator and then performs a 90° bunch rotation in longitudinal phase space, shortening the bunches to the limit of the space-charge tune shift just before extraction. The Compressor ring must

Also looking into “the limit” of space charge for accumulators. Ways around “the limit”?

Table 1.1. High-level operational parameters for the PPU and current 1.4 MW operation.

	Current SNS 1.4 MW	Full accelerator upgrade capability	FTS 60 Hz operation
Proton beam power capability (MW)	1.4	2.8	2.0
Beam energy (GeV)	1.0	1.3	1.3
Proton pulse length on target (μs)	0.75	0.75	0.75
RFQ* output peak beam current (mA)	33	46	46
Average linac chopping fraction (%)	22	18	41
Average macropulse beam current (mA)	25	38	27
Pulse repetition rate (Hz)	60	60	60
Macropulse length (ms)	1	1	1
Ring extraction beam gap (ns)	250	200	450
High-beta cryomodules	12	19	19
Proton per pulse capability	1.55×10 <sup>14</sup>	2.24×10 <sup>14</sup>	1.60×10 <sup>14</sup>
Energy per pulse (kJ)	23	47	33

\* RFQ = radio frequency quadrupole

# SNS – Today

- 1.0 GeV H- linac – 1 ms long pulse
- 1.0 GeV accumulator ring – no acceleration
- 700 ns long pulse at extraction
- $h=1, 2$  RF for extraction gap, bunch flattening
- $1.55E14$  ppp (24  $\mu\text{C}$ )
- 60 Hz operation – 1.4 MW average power

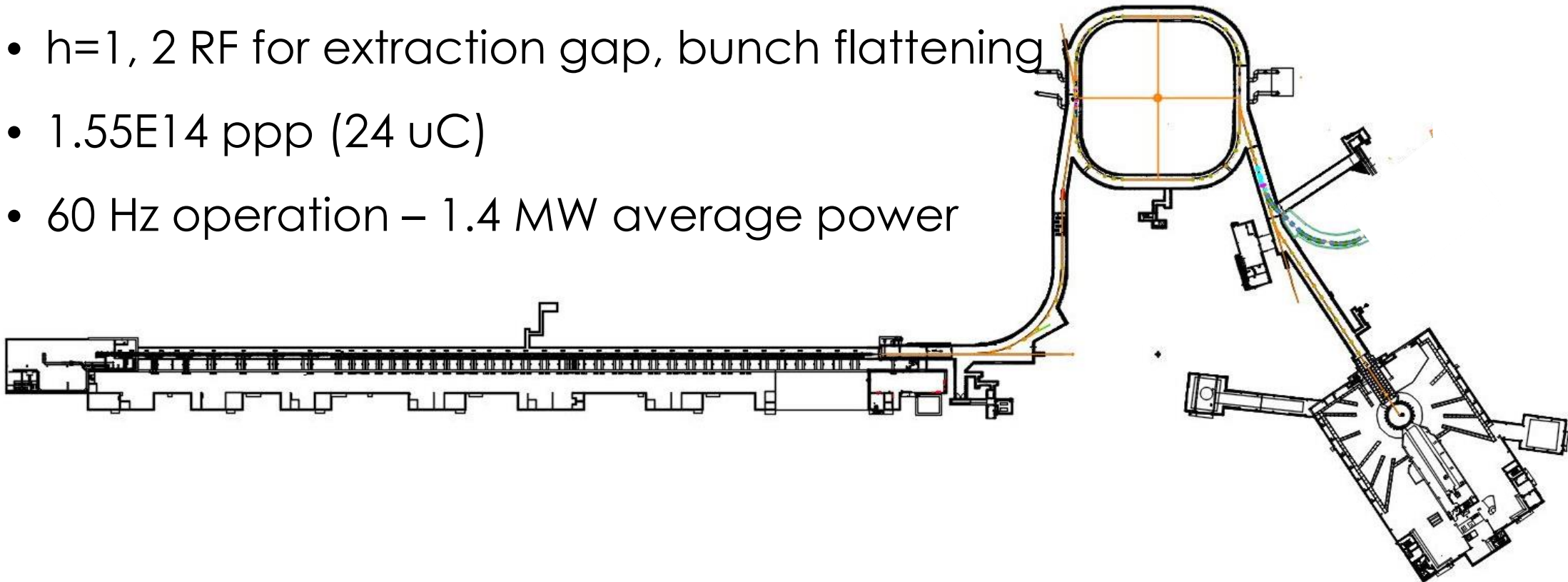

# SNS – Proton Power Upgrade (PPU) (2024)

- 1.3 GeV H- linac – 1 ms long pulse
- 1.3 GeV accumulator ring – no acceleration
- 660 ns long pulse at extraction
- $h=1, 2$  RF for extraction gap, bunch flattening
- $2.25E14$  ppp (36  $\mu\text{C}$ )
- 60 Hz operation – 2.8 MW capable

800 kW of idle power for a decade – what should we do with it?

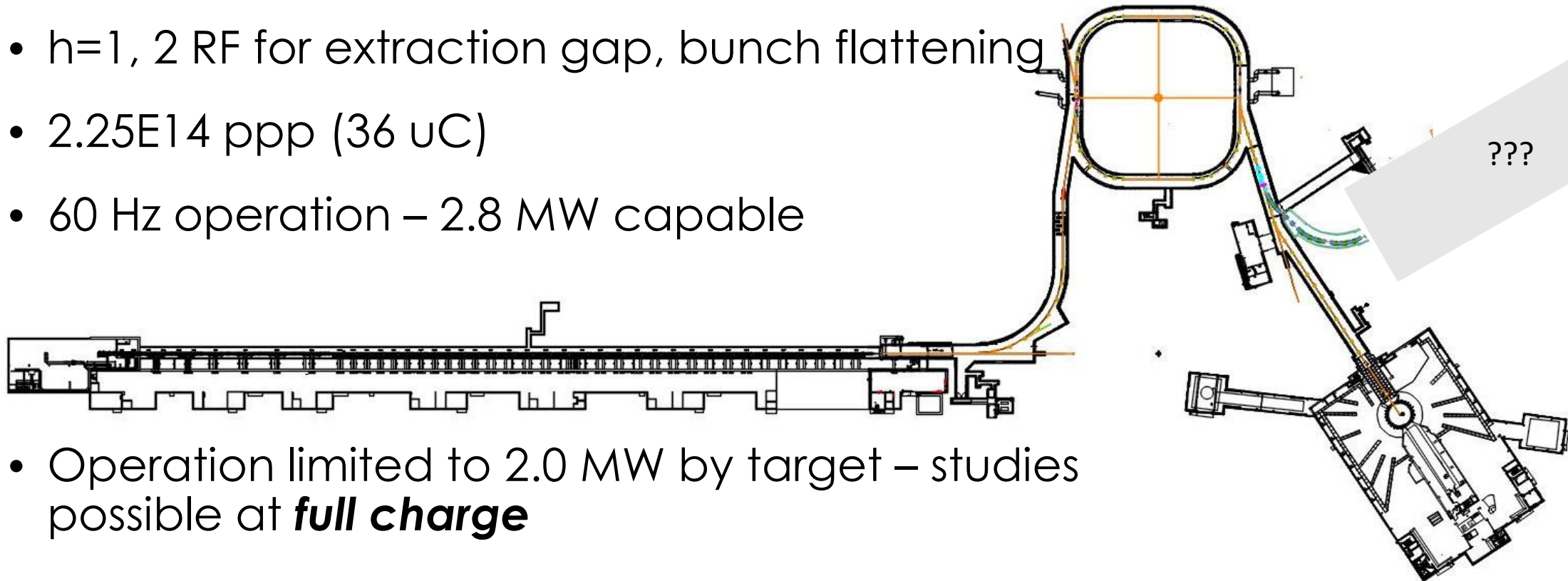

- Operation limited to 2.0 MW by target – studies possible at **full charge**

# SNS – Second Target Station (mid-2030's)

- Accelerator is identical to PPU with additional 700 kW target station
- Accelerator operates at 60 Hz, 2.7 MW
  - 700 kW to STS at 15 Hz
  - 2 MW to FTS at 60 Hz  $\frac{3}{4}$  duty cycle

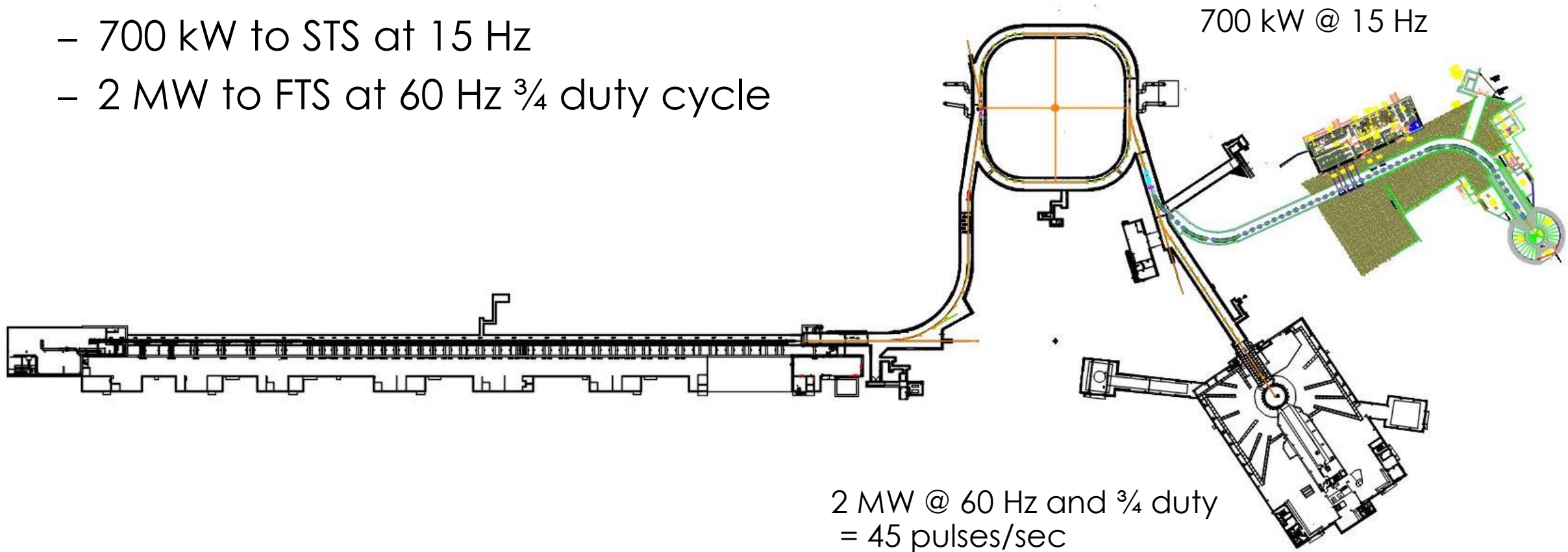

# Bunch Compression at SNS – Proposal

Holmes et al. HB2006 THAW03

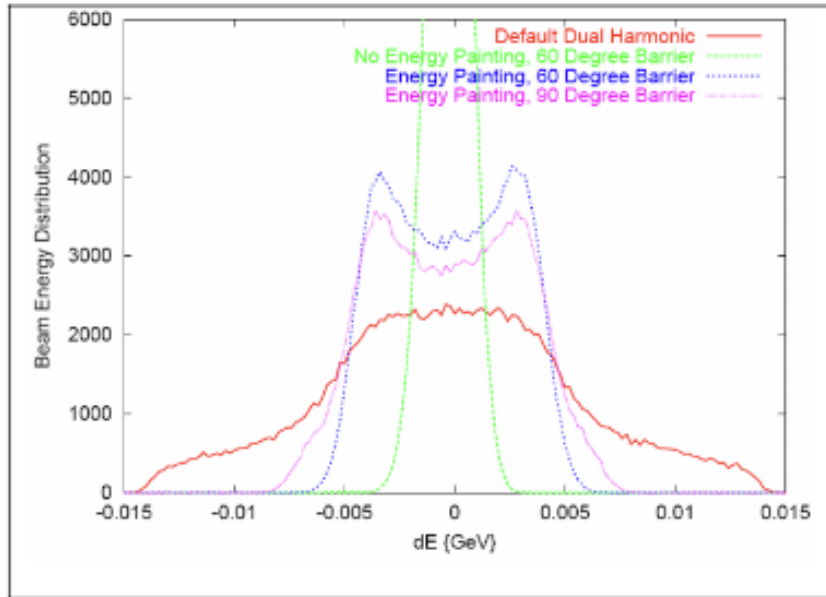
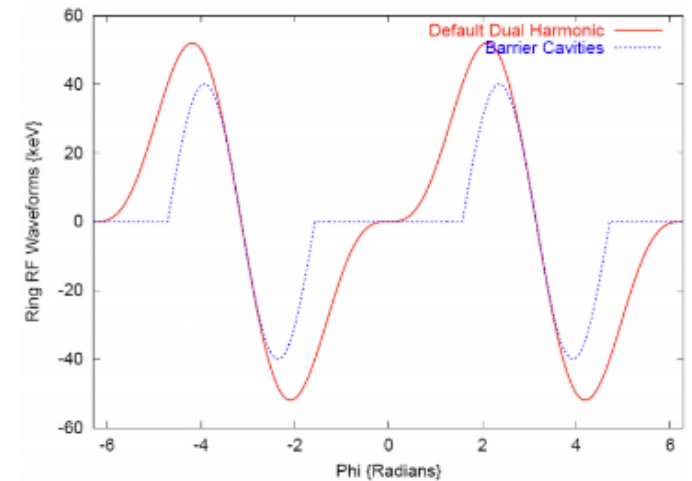

**FIGURE 2.** Energy distributions at the end of injection for different RF waveforms.

Difference between red and green is essentially an indication of max bunch compression we could get.

- High bandwidth ring RF allows control of bunch structure – SNS does *NOT* currently have a barrier RF system
- Explored early on to reduce peak intensity in the ring to combat instabilities, but there is potential for bunch compression
- SNS linac energy spread is not matched to much larger acceptance of ring offering opportunity for large bunch compression putting us in the longitudinal space charge regime of MCPD
- Could support simulation and experimental program with funding

Barrier cavity waveforms (blue) used for simulations vs. SNS design waveforms (red) currently available



# Self-Consistent Beams – Current Experimental Program

- Actively working to paint self-consistent Danilov distribution (*Danilov et al. PRSTAB 6, 094202*) in SNS ring – reduce space charge tune shift, spread – **overcome space charge limit?**
- Next step is to explore space charge dynamics – funding uncertain
- Also has benefits for a collider, but not sure how to apply to muons (see. *Burov, PRSTAB 16, 061002*)

Holmes et al. HB2006 THAW03

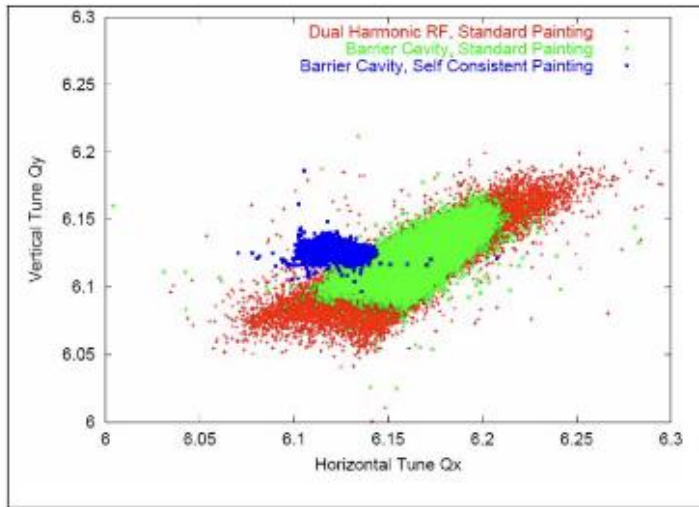

**FIGURE 3.** Tune footprints for three different RF and painting scenarios.

Simulation showing reduced tune footprint for  $2.5E14$  self-consistent bunch in SNS ring

x-y' Correlations paintable with flexible SNS kicker system allow injection of uniform density bunches.

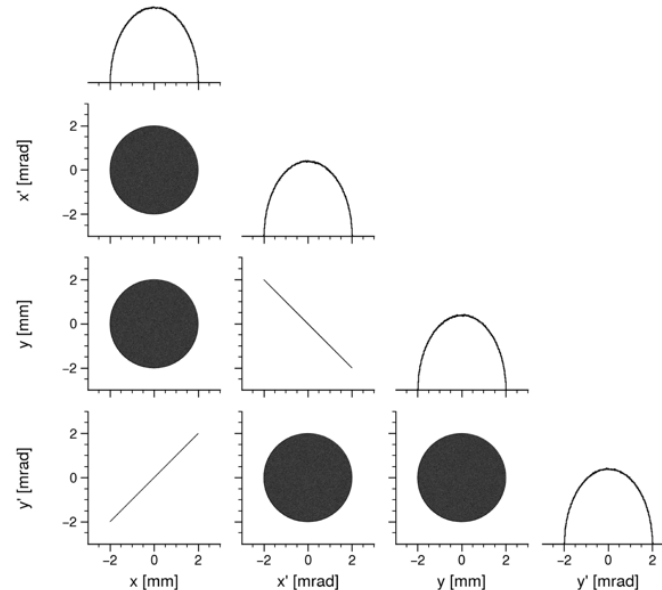

• Data  
 — Gaussian Fit  
 — Elliptical Fit

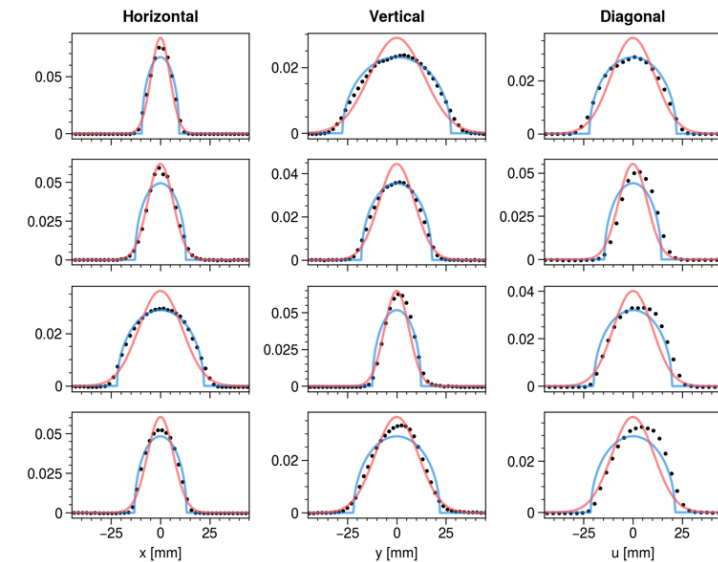

Uniform density manifests as elliptical profiles in wire scanners.



# Laser Assisted Charge Exchange – Current Experimental Program

- For multi-MW injection with material interaction is problematic interaction with photons is the obvious alternative
- SNS is the **ONLY** H- linac capable of testing LACE operationally

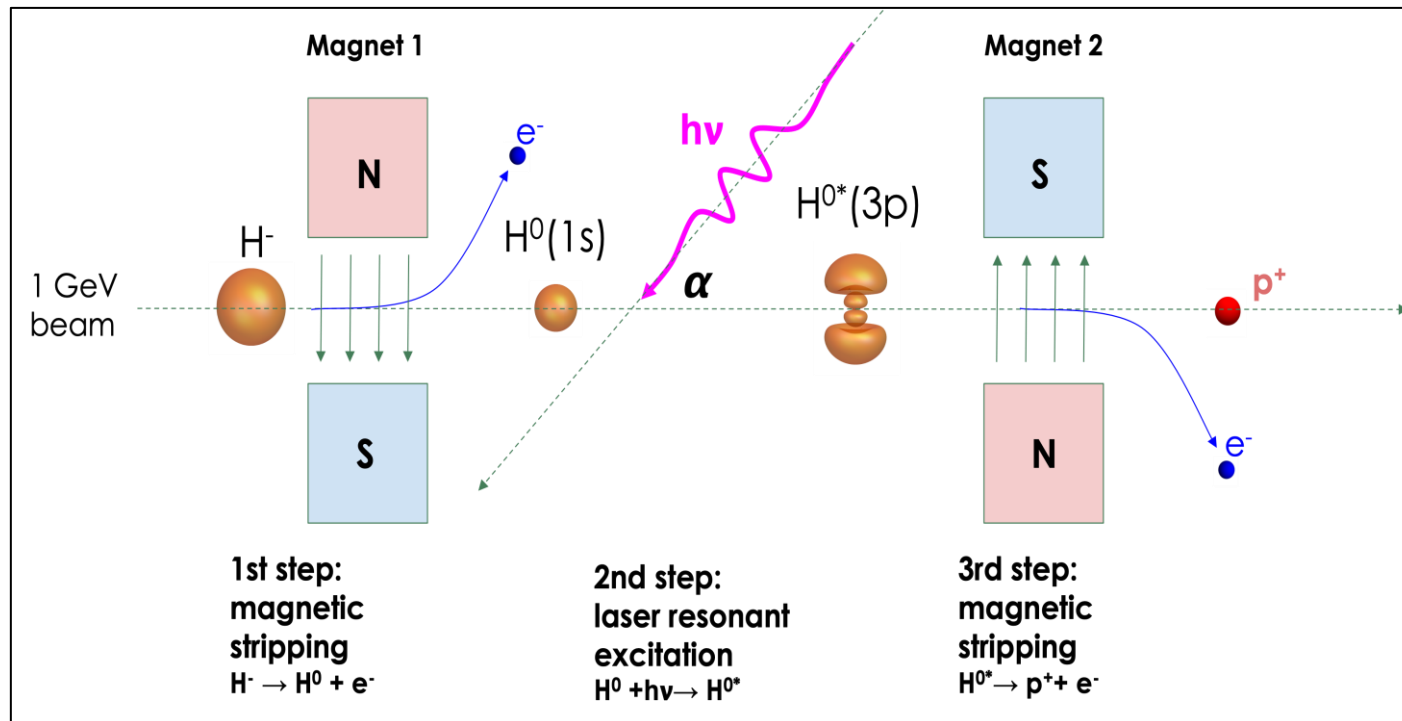

With foils, injection area  
>1 rem/h @ 30 cm 3-5 hrs  
after operation

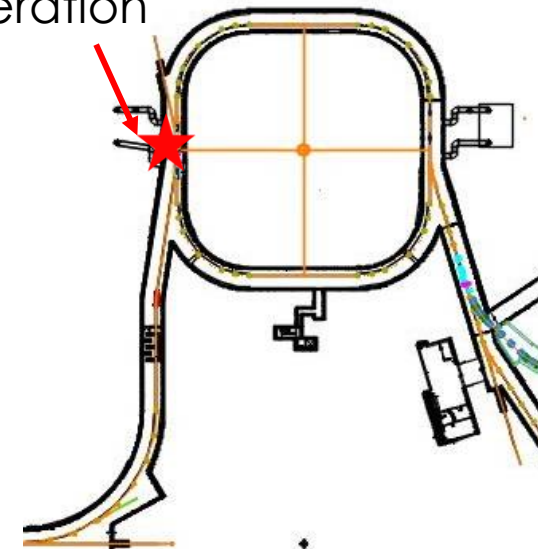

# The laser power challenge for LACE has been SOLVED

6ns

10us

1 ms capable

1 ms optimization

2006  
Proof of principle

2016  
10us  
Experiment

2018  
Sequential  
Resonance  
Excitation scheme  
proposed

2020  
Experimental Vessel  
Modified for  
Sequential  
Resonance

2022  
Experimental  
Demonstration of  
Sequential  
Resonance

2023  
Demonstration of  
laser crab crossing  
technique

2023 Development  
of new Chamber,  
Design of injection  
demonstration  
system start

A slew of innovations to maximize utility of available laser power puts an operational system within reach  
~1-2 kW average power,  
1 MW peak power

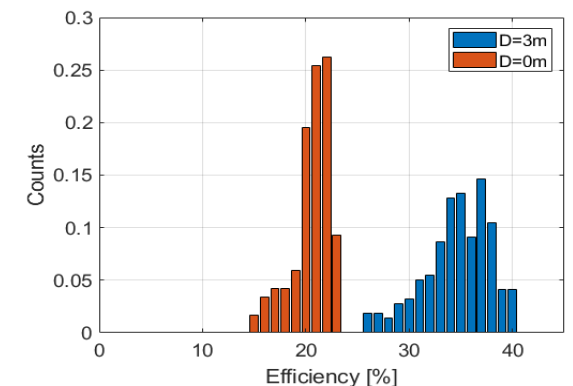
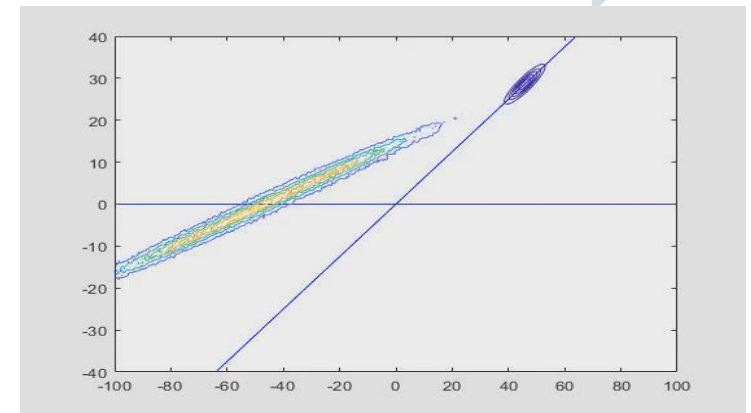
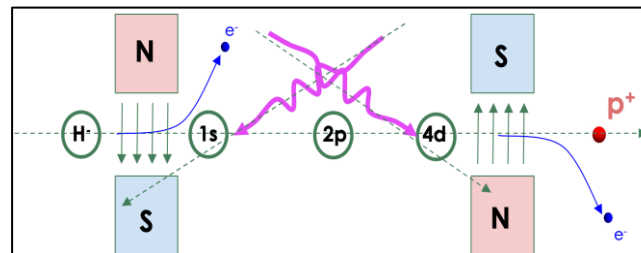
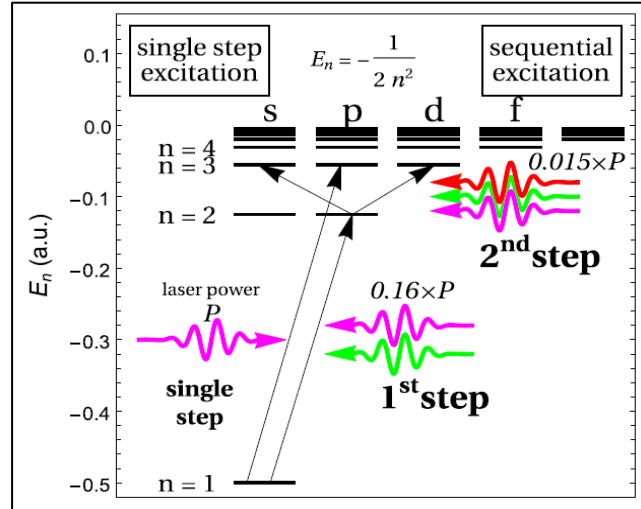

# Toward Operational LACE - Proposal

- Working on conceptual design of ring injection demo system in SNS – real ring injection, *not* stripping studies
- SNS is the **only** option for testing operational LACE
- Plan is to utilize long shutdown in 2028, but funding source is not secure!

Ring Injection

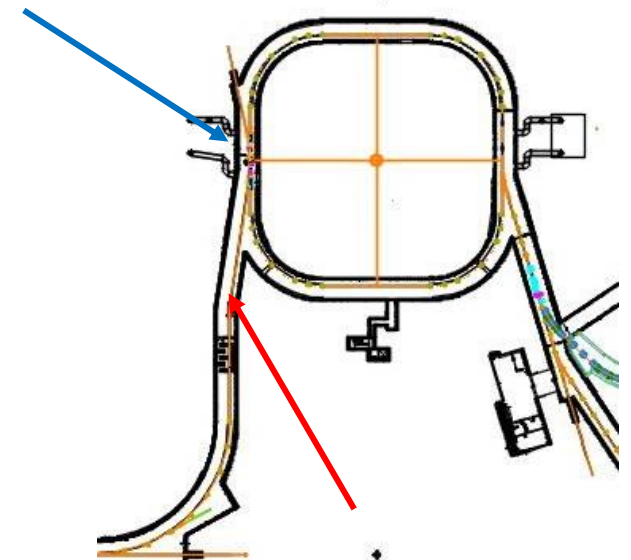

Existing LACE experiment station

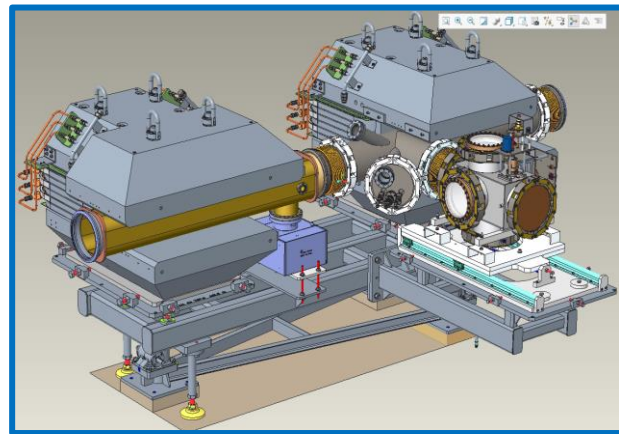

Post-PPU injection region is tight – engineering will be a challenge

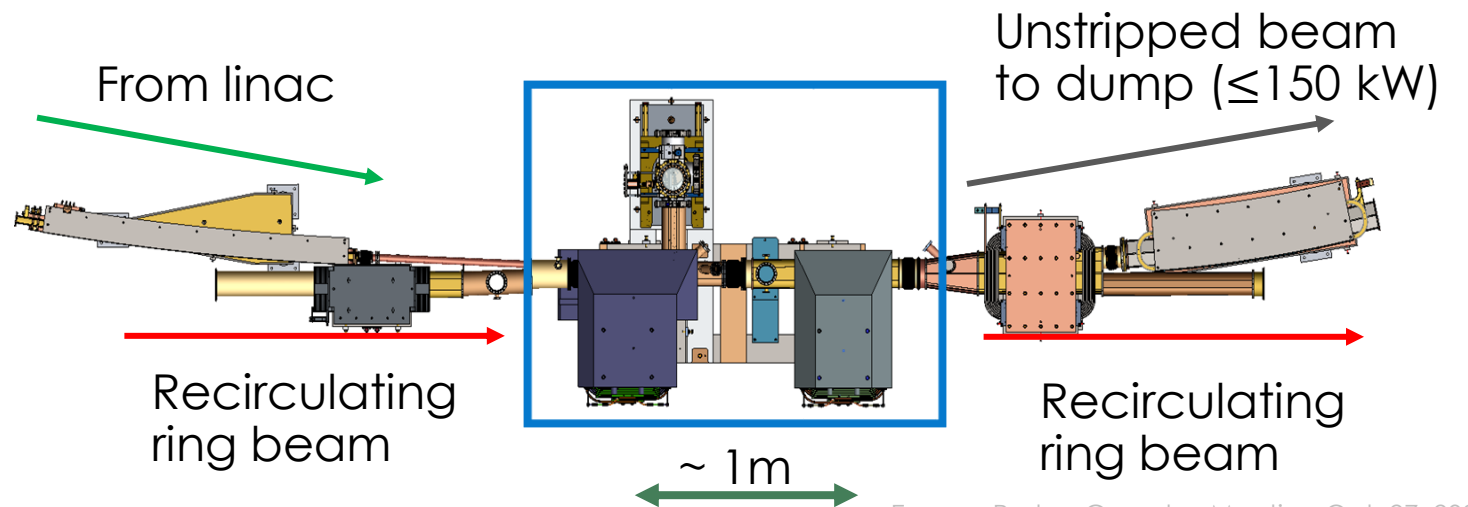

# Spallation Neutron Source – High Power Beam, High Impact R&D

- 1.0 GeV (1.3 GeV after upgrade) super conducting H- linac
- 1.4 MW (2.8 MW in 2024) average power
- $1.55 \times 10^{14}$  ppp ( $2.24 \times 10^{14}$  after upgrade)
- Capable of 4D transverse phase space painting for distribution tailoring
- Active laser assisted charge exchange injection R&D program
- Active self-consistent beam program to push limits of space charge in high intensity machines
- Beam Test Facility (BTF) - full 6D phase space, and high-dynamics range measurements

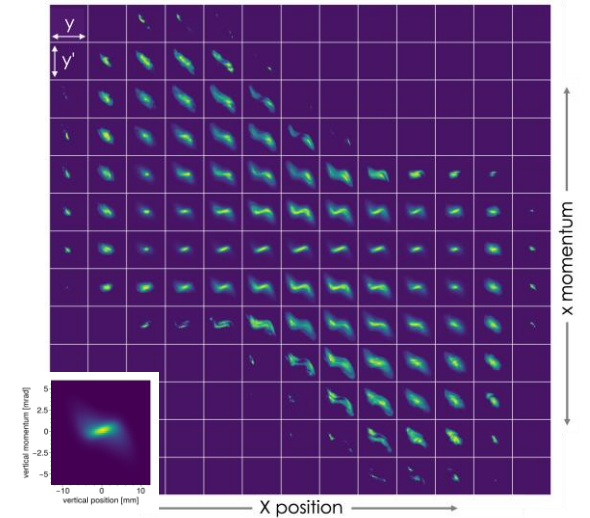

Direct 4D phase space measurement at BTF for understanding the origin of beam loss

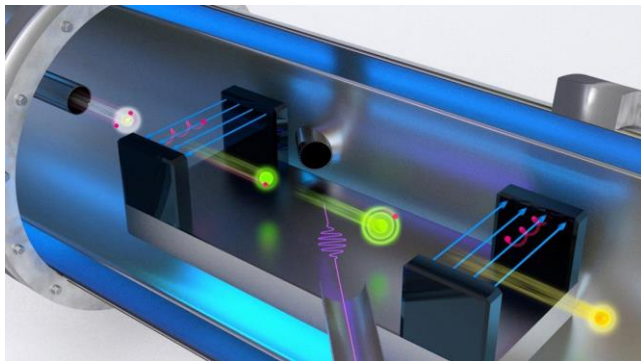

Laser assisted Charge Exchange Experiments at full energy – a path to replace foil-based injection

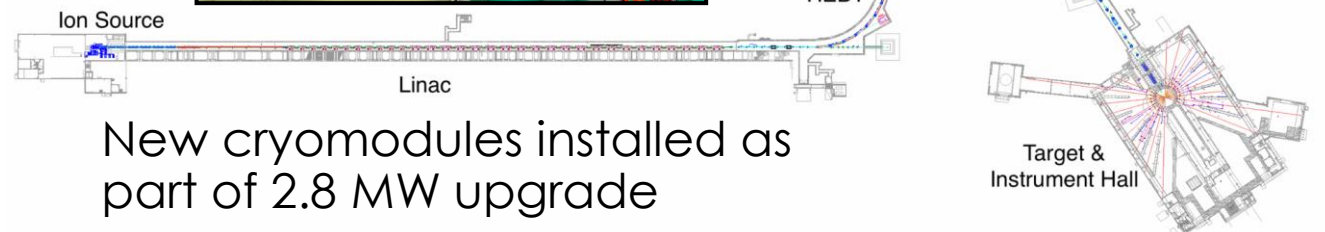

New cryomodules installed as part of 2.8 MW upgrade

# Summary

- SNS resembles some conceptions of a Muon Collider Proton Driver, particularly in charge per pulse
- Space charge limit for bunch compression is an open question, experimentally accessible at SNS
- Currently exploring techniques to push space charge limit that could benefit MCPD
- SNS is the only linac capable of testing operational laser assisted charge exchange injection – in active development, looking for funding
- Soliciting ideas for  $1.5\text{-}2.25 \times 10^{14}$  bunch at 1.3 GeV, 15 Hz
- SNS ready to contribute to Muon Collider R&D

# Extra Slides