



PRACTICAL SESSION

Design and dimensioning of an accelerator's
equipment

Exercise 2

Prepared by Marc Timmins and Tamino Wirz



ENGINEERING
DEPARTMENT



MECHANICAL & MATERIALS ENGINEERING
FOR PARTICLE ACCELERATORS AND DETECTORS

Disclaimer

The following exercise has been prepared explicitly for the Mechanical and Materials engineering CAS for educational purposes and by no means represent a functional component used in an accelerator.



You have completed the 3D design of a complete system(CASME001) , and you need to produce the detailed drawing of the vacuum chamber (CASME002) complying to the 5 functional requirements described in slide 5.

Material required for the exercise:

Pencil

Eraser

ISO GPS handbook

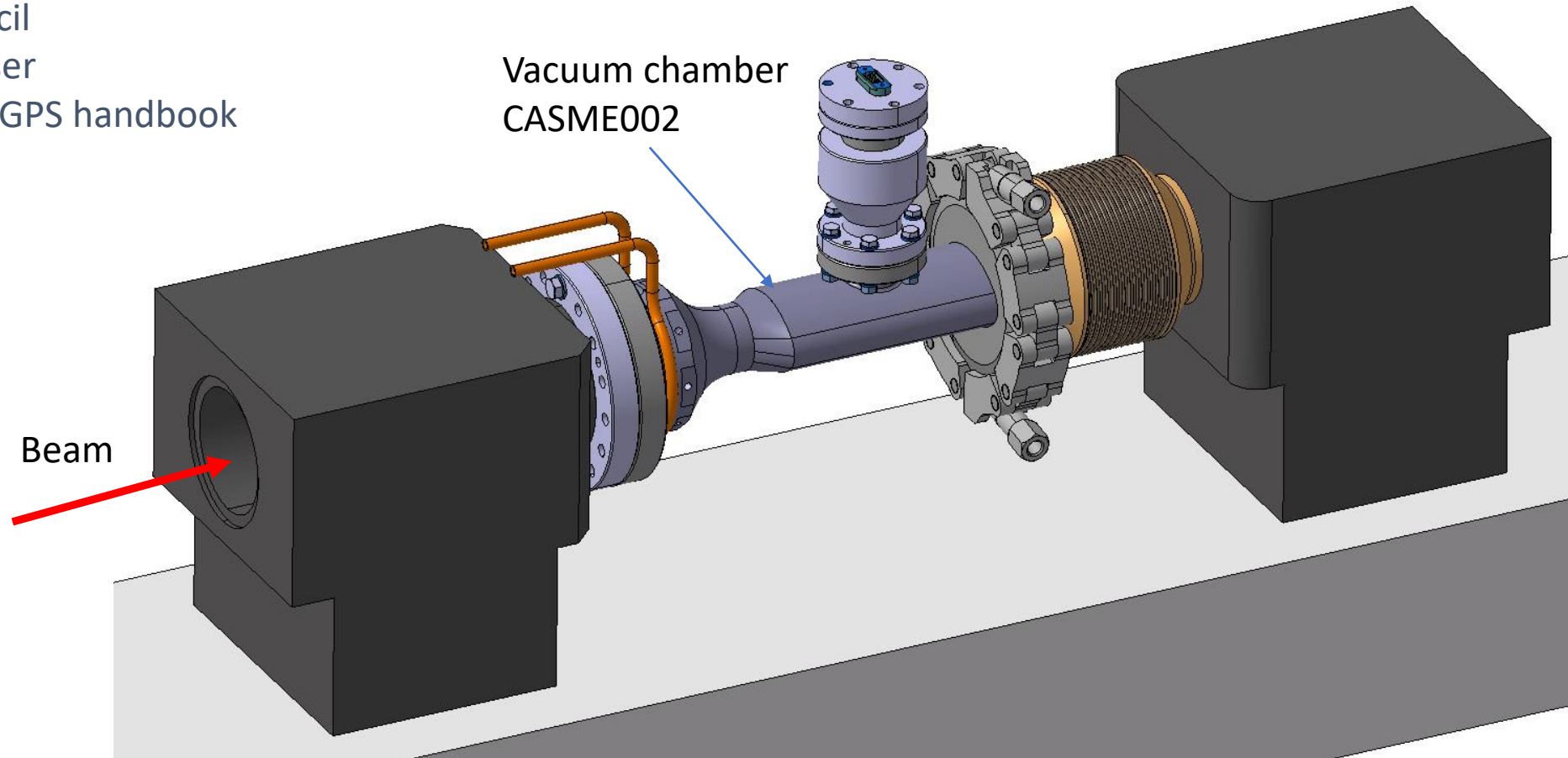

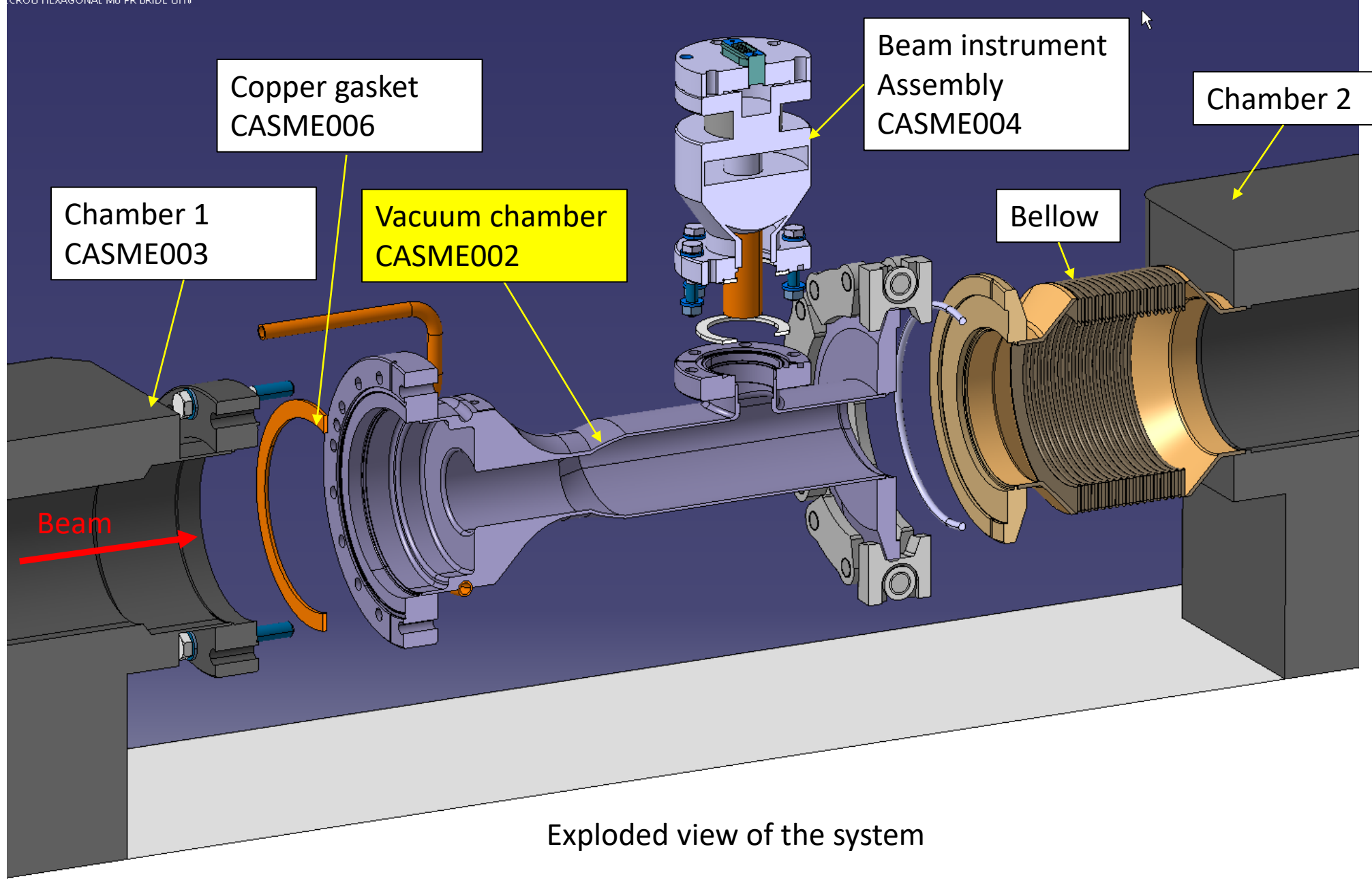

Exploded view of the system

Functional requirements to be read in conjunction with drawing CASME001 and slide 4:

F1 – Surface Alpha (not the axis) must be positioned within an envelope of $\pm 0.6 \text{ mm}$ around a nominal diameter of **42 mm** and perfectly centred on the beam.

F2 – Surface Beta, belonging to the beam instrument assembly, needs to be positioned horizontally at **23.2 mm $\pm 0.6 \text{ mm}$** from the beam.

F3 – Position the conical flange considering a maximum allowed transverse stroke of the bellow to be $\pm 2 \text{ mm}$ around its nominal position and an axial stroke of $\pm 1 \text{ mm}$.

F4 – Surface Gamma (not the axis) needs to be positioned within $\pm 1 \text{ mm}$ with respect to the beam

F5 – All mating surfaces must have a flatness tolerance of **0.1** and **Ra roughness of 1.6**.

Assumptions:

- Angular defects are neglected
- Welded assemblies are considered as one single part.
- The flange in chamber 1 (CASME003) is considered perfectly centred to the beam.
- The vacuum chamber (CASME002) is centred by the copper gasket (CASME006).
- Chamber 1 (CASME003) and bellow are perfectly aligned with respect to each other.

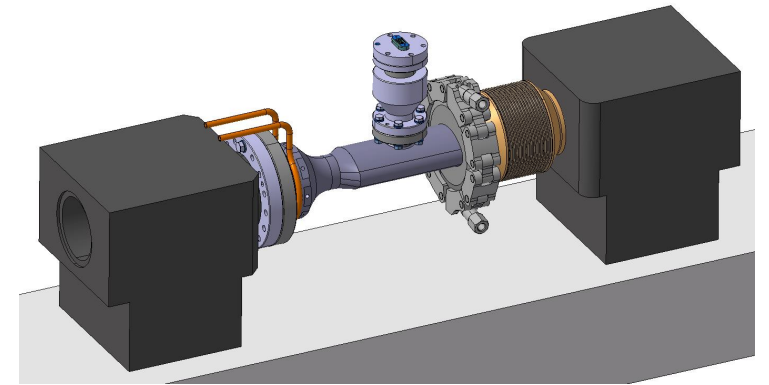

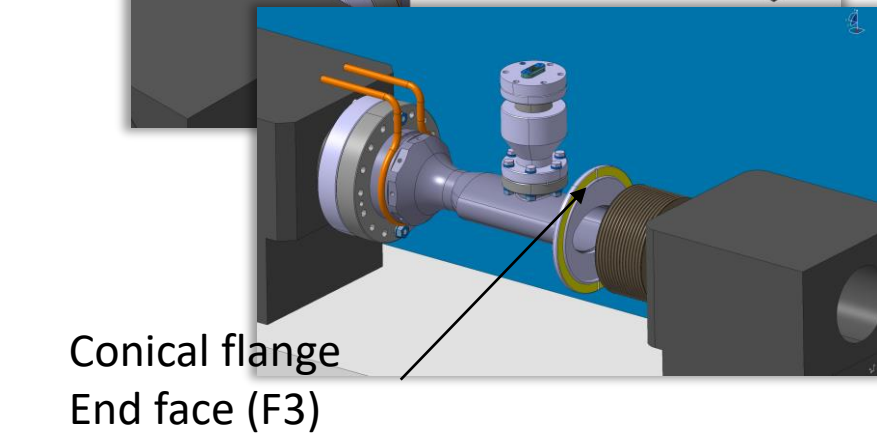
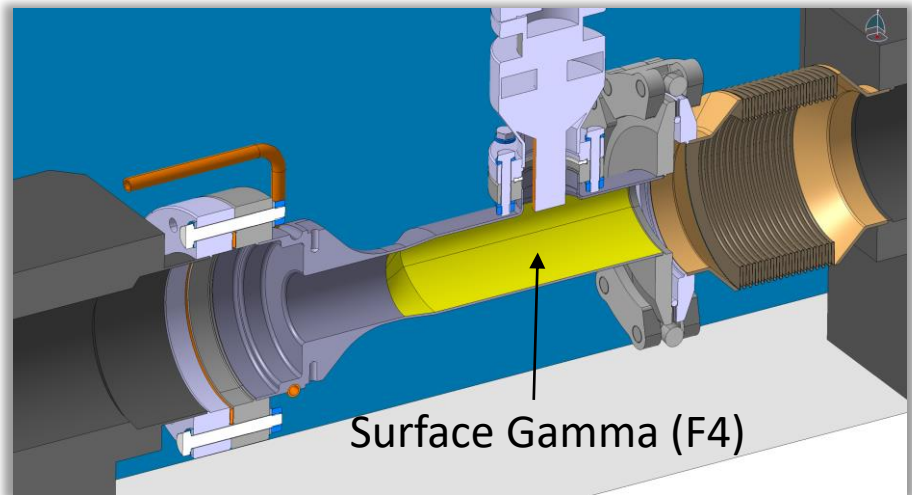
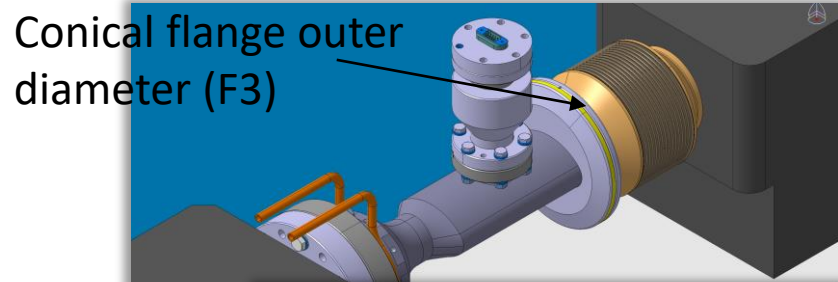
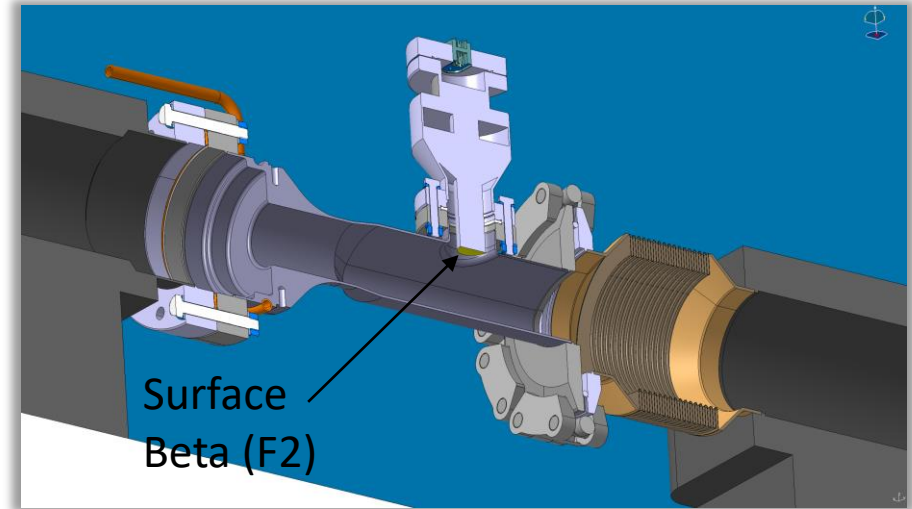
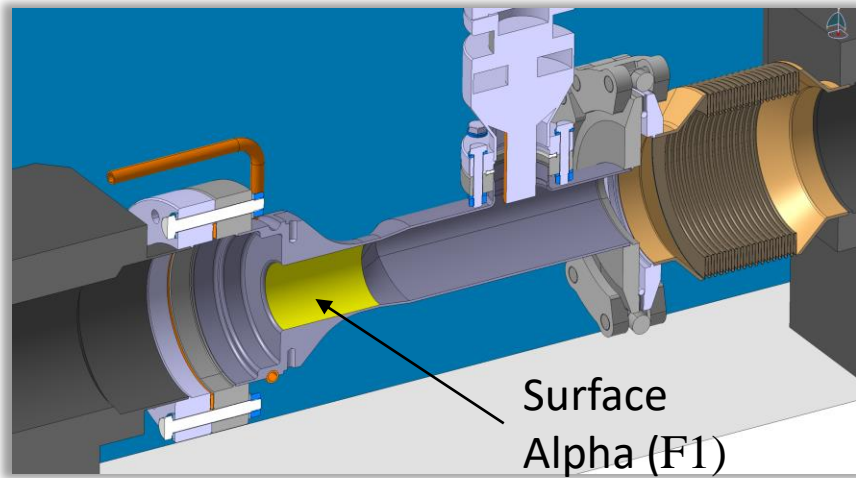

Questions:

- 1 – From your analysis of the system, define and indicate on the drawing of the vacuum chamber (CASME002), the primary, secondary and tertiary datums (A, B and C) according to ISO GPS norms and fill in the isostatic table
- 2 – Define and indicate on the drawing of the vacuum chamber CASME002 the appropriate ISO GPS symbol inside each existing geometrical specification box in order to fulfil the technical requirements F1, F3 and F5.
- 3 – Identify on the drawing of the vacuum chamber CASME002 the surface which relates to technical requirement F2 and indicate the appropriate geometrical specification symbol.
- 4 – Define and indicate on the drawing of the vacuum chamber CASME002 inside each existing geometrical specification box, the datums needed to position the specified surface.



Questions:

5 – Calculate the maximum misalignment (X_{max}) of the vacuum chamber (CASME002) with respect to the beam axis considering the dimensions and tolerances on the flanges and copper gasket with the help of the picture below.

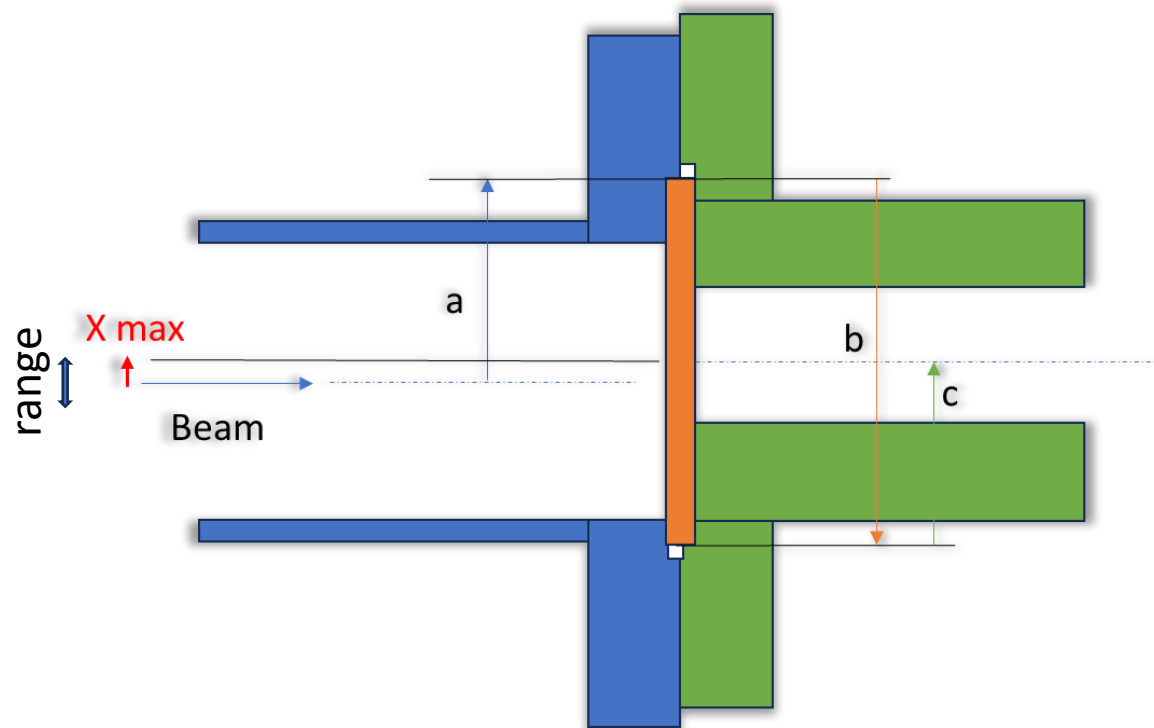

Answer:

Chamber 1 (a) =

Copper gasket (b) =

Vacuum chamber (c) =

X_{max} =

6 – From the result obtained in question 5 determine the maximum misalignment range:

7 – Considering the misalignment range calculated in the previous question, calculate the remaining maximum allowed tolerance range applicable to each geometrical specification indicated on the drawing of the vacuum chamber CASME002 in order to fulfil functional requirements F1, F2, F3, F4.

Answer:

Maximum allowed tolerance range for F1:

Maximum allowed tolerance range for F2:

Maximum allowed tolerance range for F3:

Maximum allowed tolerance range for F4:

8 – Indicated on the drawing of the vacuum chamber CASME002 each tolerance value previously calculated inside its corresponding geometrical tolerance box (except for F4).

9 – What alternative ISO GPS geometrical specification symbol could you use to express the functional requirement F1 ?

Answer

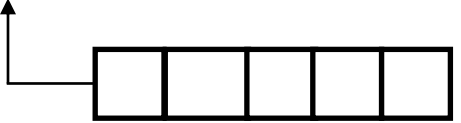

10 – In what way is the diameter 42 on surface Alpha affected by your answer to the previous question ?

Answer :

11 – What would be the new tolerance range value using the alternative ISO GPS geometrical specification symbol ?

12 – Define and indicate on the drawing of the vacuum chamber CASME002 the appropriate geometrical specification symbol, the tolerance value and the datums needed to position the specified surface in order to fulfill technical requirement F4.

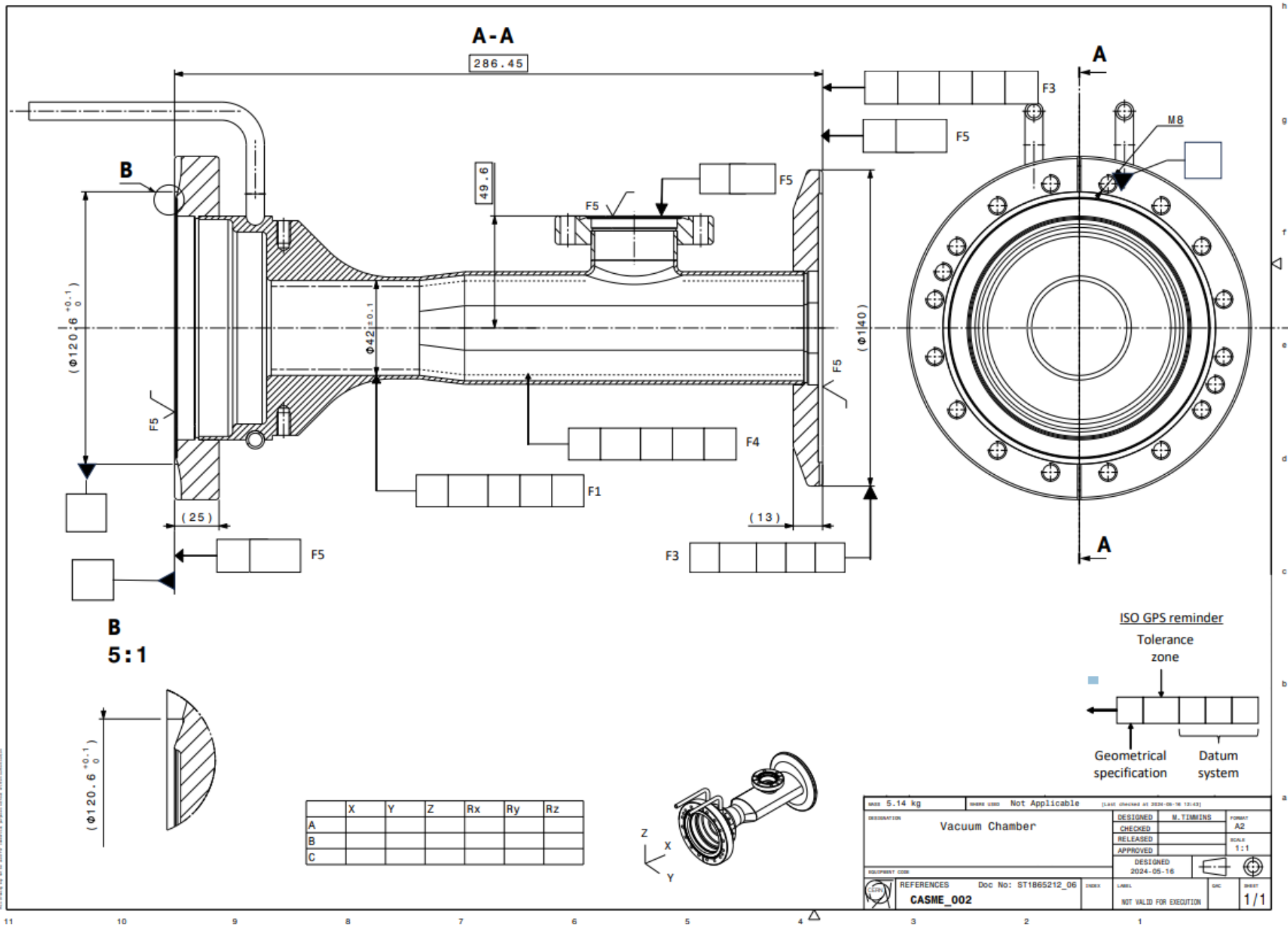

REVISIONS AND APPROVALS FOR
DRAWING AND EXECUTION OF WORKING DRAWINGS
DATE: 2024-05-16

WEIGHT	5.14 kg	WORK USED	Not Applicable	(LAST CHANGED AT 2024-05-16 12:42)
DESIGNATION	Vacuum Chamber			FORMAT A2
DESIGNED	M. TIMMINS			SCALE 1:1
CHECKED				
RELEASED				
APPROVED				
DESIGNED	2024-05-16			
REFERENCES	Doc No: ST1865212_06	INDEX	LABEL	QC
CASME_002				1/1
NOT VALID FOR EXECUTION				





We hope you enjoyed the
practical session

Thank you for your attention and work done



ENGINEERING
DEPARTMENT



MECHANICAL & MATERIALS ENGINEERING
FOR PARTICLE ACCELERATORS AND DETECTORS

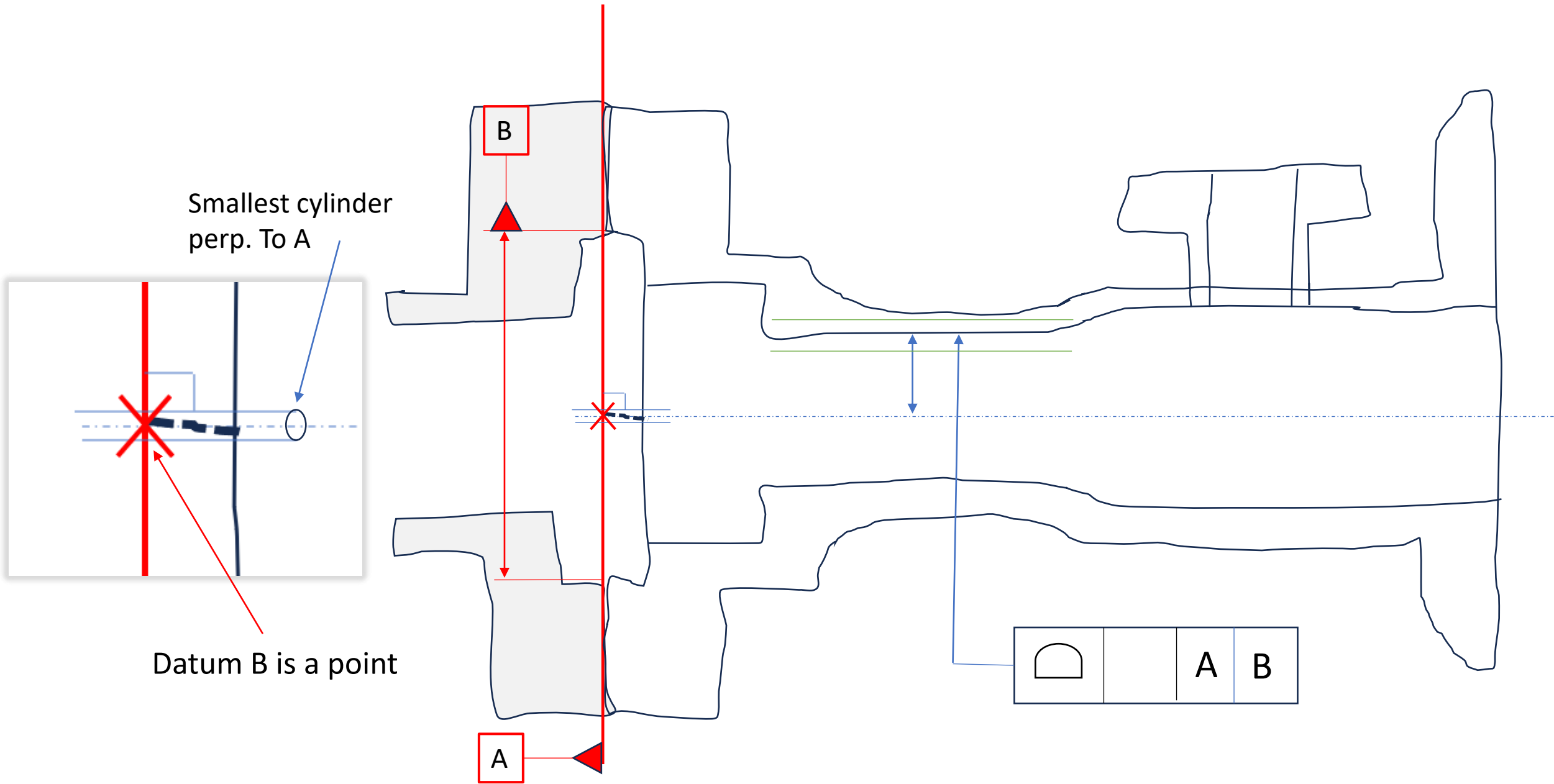

Smallest cylinder around
extracted axis

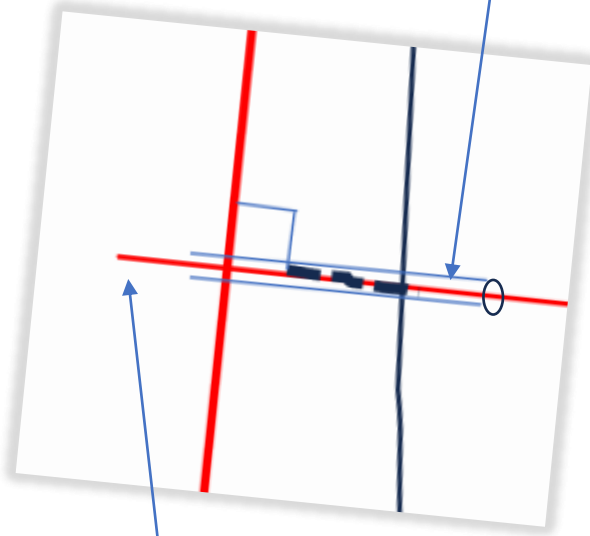

Datum A is a line

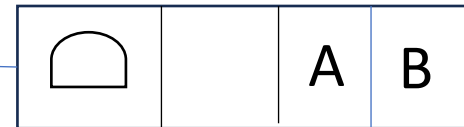
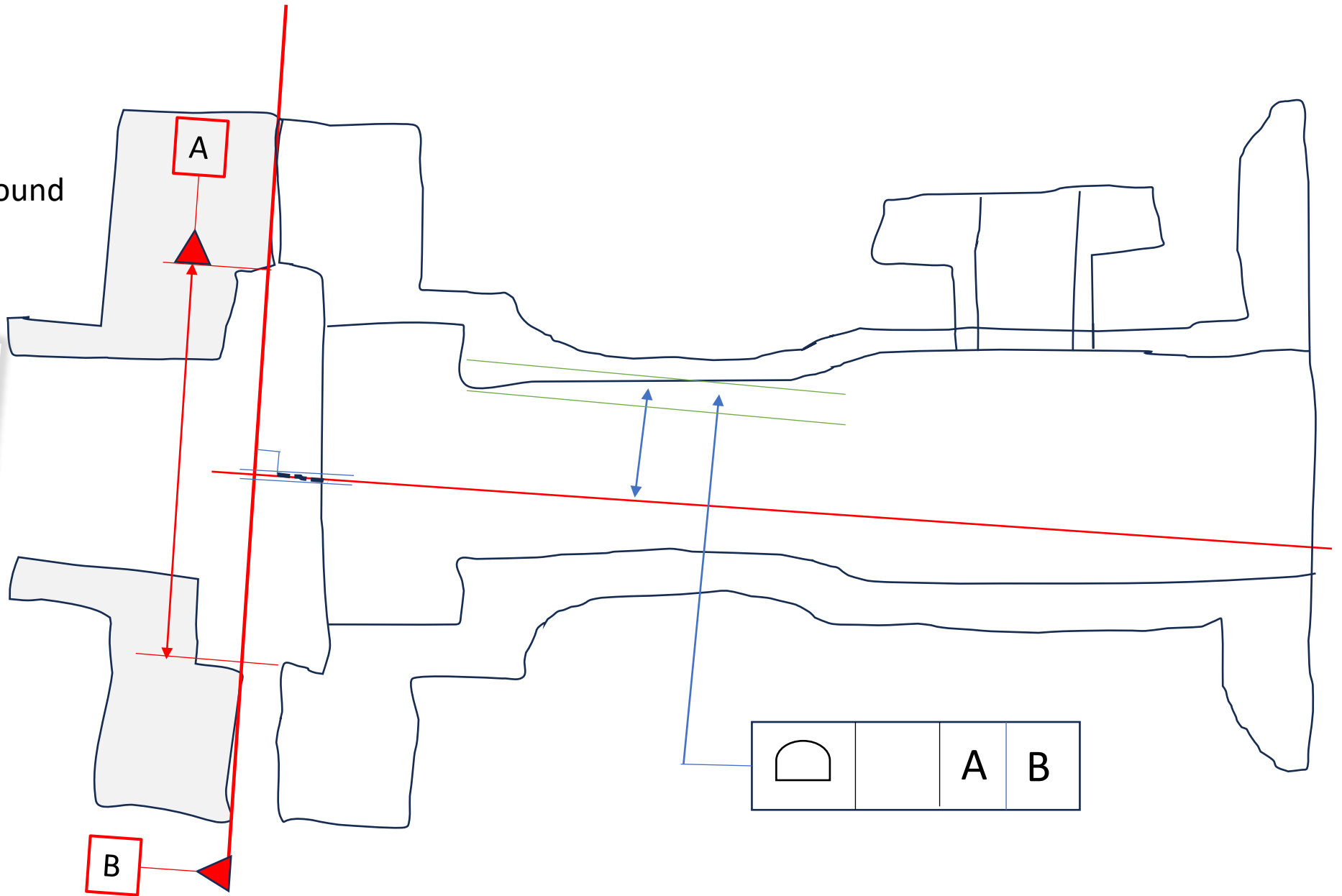

Smallest cylinder around extracted axis

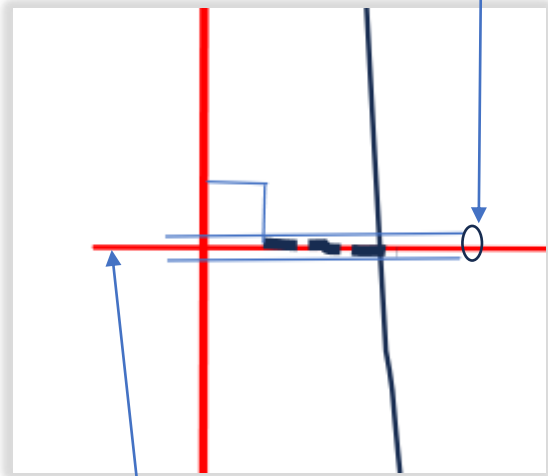

Datum A is a line

