

Search for evidence of the baryon junction in photonuclear processes and heavy-ion collisions

Chun Yuen Tsang

Kent State University, Brookhaven National Laboratory

Forward Physics in ALICE 3

Supported in part by:



U.S. DEPARTMENT OF
ENERGY

What carries baryon number, valence quark vs. baryon junction?

Valence quark

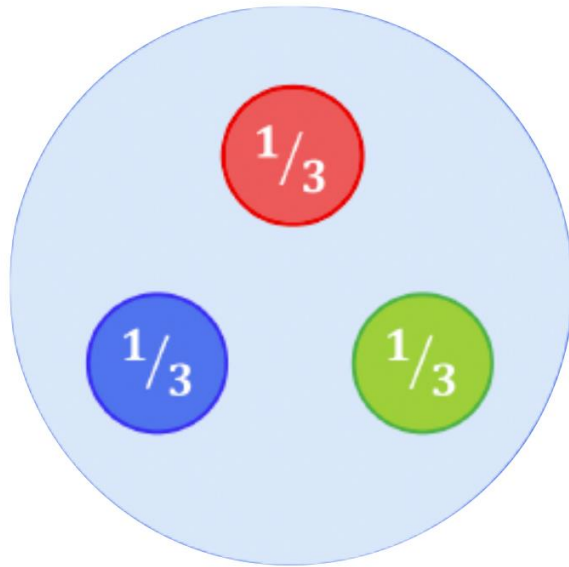

Conventional picture

Baryon junction [1, 2]

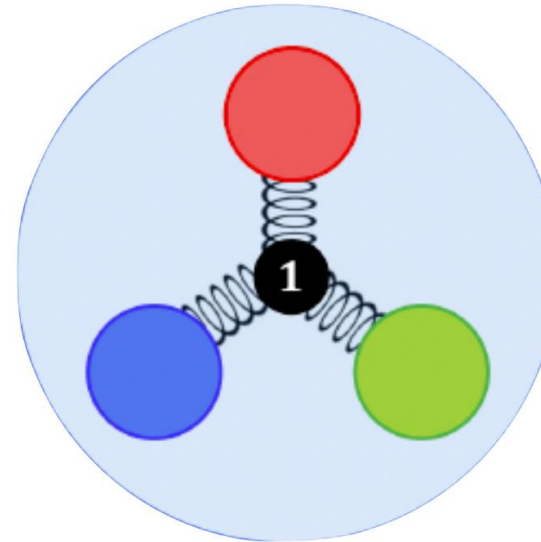

[1]: Artru, X. String Model with Baryons: Topology, Classical Motion. Nucl. Phys. B 85, 442–460 (1975).

[2]: Rossi, G. C. & Veneziano, G. A Possible Description of Baryon Dynamics in Dual and Gauge Theories. Nucl. Phys. B 123, 507–545 (1977)

Net-Baryon at mid-rapidity

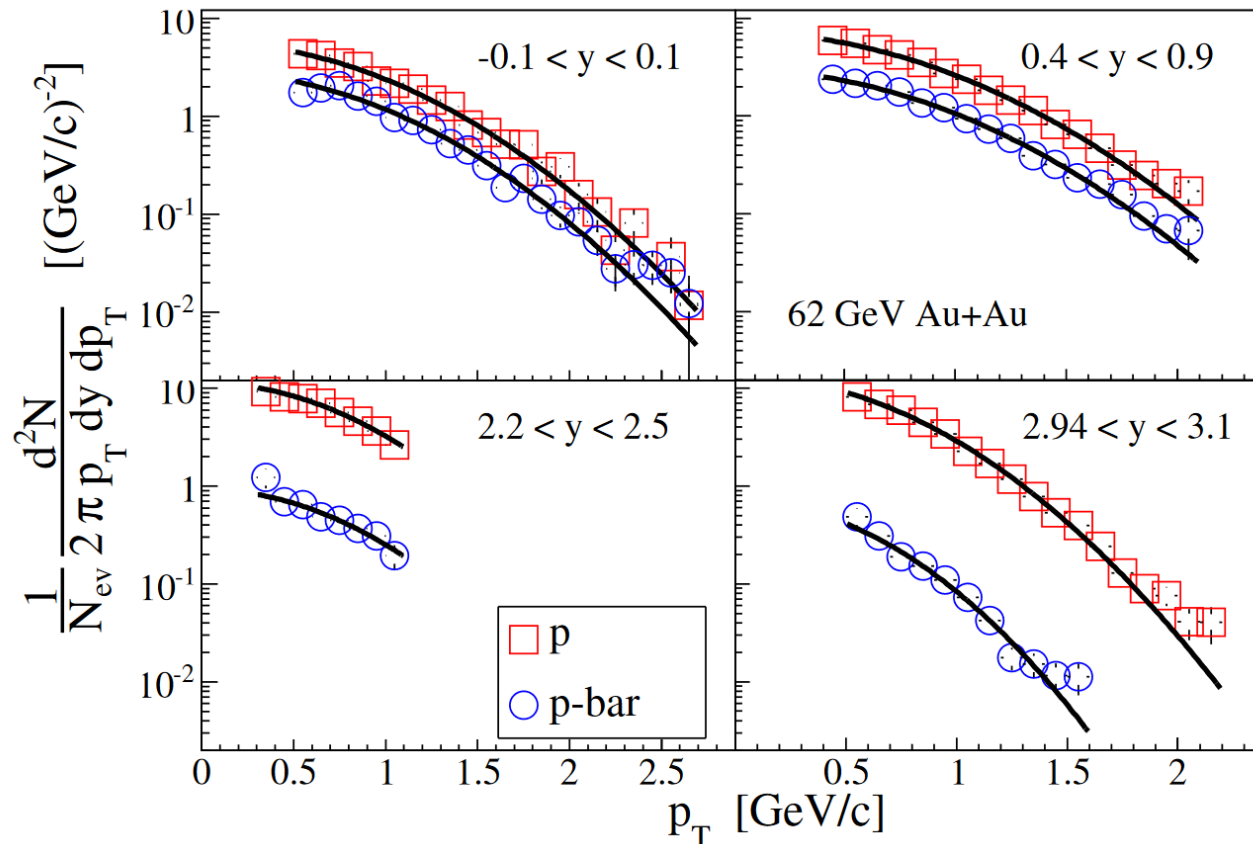

BRAHMS Collaboration, Phys. Lett. B **677**, 267-271 (2009)

- Net-Baryon = $p - \bar{p}$
- More baryons than antibaryons, even at midrapidity
- Expected yield of $p - \bar{p}$ is low
- Collision time is too short for a lot of valence quarks to be stopped



Net-Baryon at mid-rapidity

- **Changes with collision energy**

- Higher energy => Less interaction time

- **Normalized net-Baryon yield at mid-rapidity shows a clear exponential dependence on δy**

- Exponential factor too small to be explained by the valence quark picture

C. Shen and B. Schenke, PRC **105**, 064905 (2022)

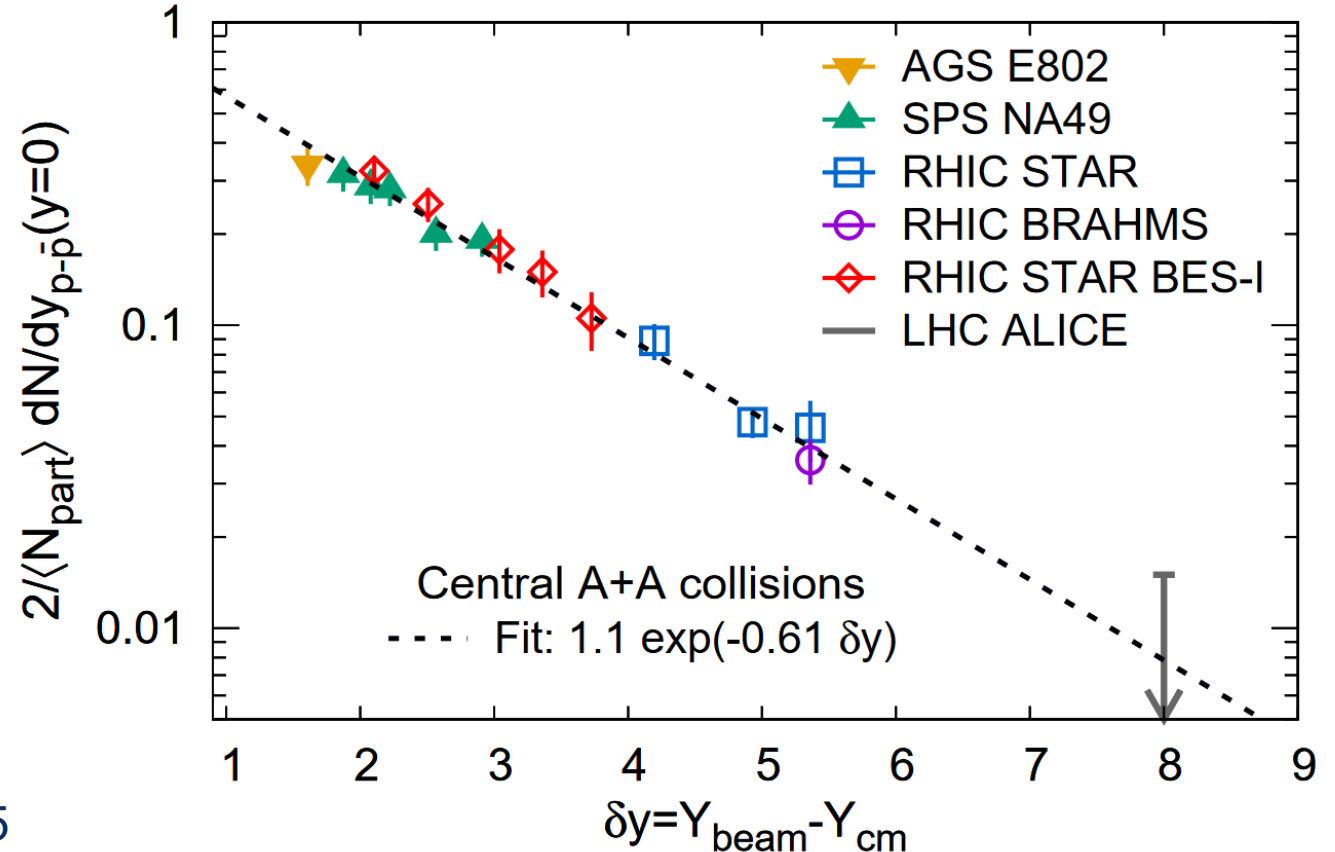

J. D. Brandenburg, N. Lewis,
P. Tribedy, Z. Xu, arXiv:2205.05685
(2022)

Baryon transport from junction

- **Valence quarks carry most of the momentum and are contracted into thin “pancakes” at high energy**
 - Quarks have less time to interact due to contracted longitudinal length
- **Junction carries lower momentum and is less contracted**
 - Junction is made of low- x gluons
 - More time to interact with other partons
 - Enhanced baryon transport to mid-rapidity

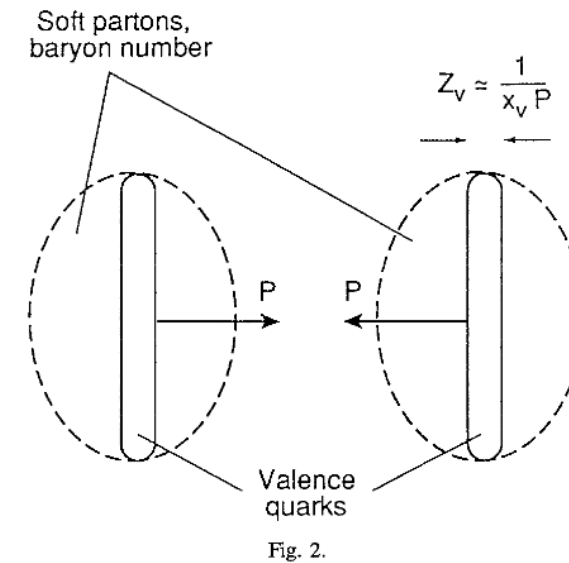
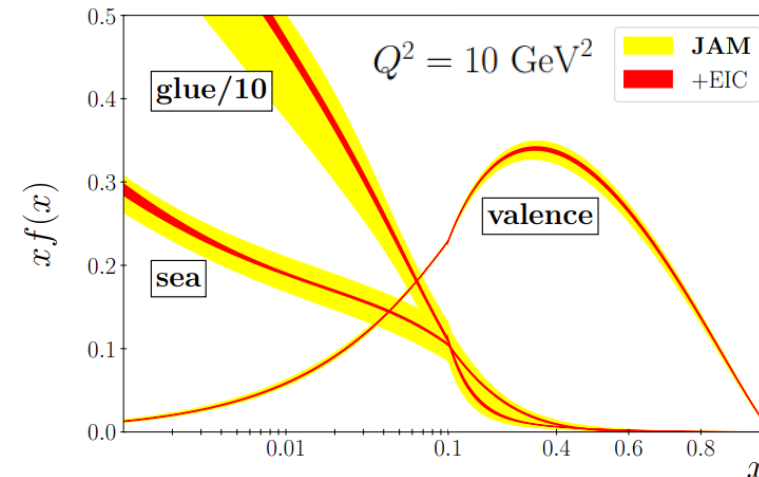

Figure from D. Kharzeev, Physics Letters B 378, 238 (1996)



R. Abdul Khalek et al, arXiv:2103.05419 [physics.ins-det]



Baryon transport from junction

- **Three methods to test the hypothesis:**
 1. **Net-Baryon vs. Net-Electric charge in Isobar collisions**
 2. Net-Baryon in photonuclear collisions
 3. Net-proton yield as a function of rapidity in hadronic Au+Au collisions

Electric charge of quarks

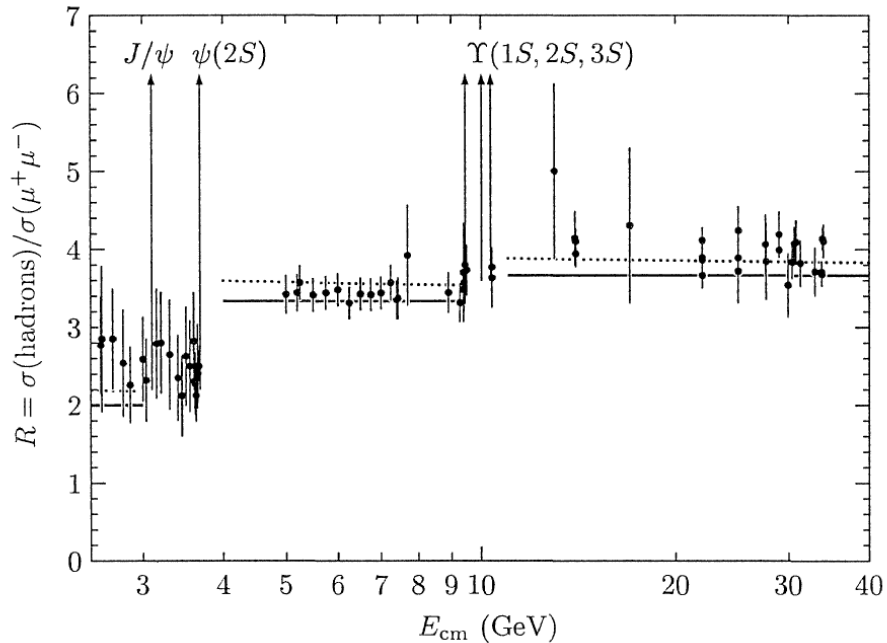

Figure 5.3. Experimental measurements of the total cross section for the reaction $e^+e^- \rightarrow \text{hadrons}$, from the data compilation of M. Swartz, *Phys. Rev. D* (to appear). Complete references to the various experiments are given there. The measurements are compared to theoretical predictions from Quantum Chromodynamics, as explained in the text. The solid line is the simple prediction (5.16).

$$\sigma(e^+e^- \rightarrow \text{hadrons}) \xrightarrow{E_{\text{cm}} \rightarrow \infty} 3 \cdot \left(\sum_i Q_i^2 \right) R, \quad (5.16)$$

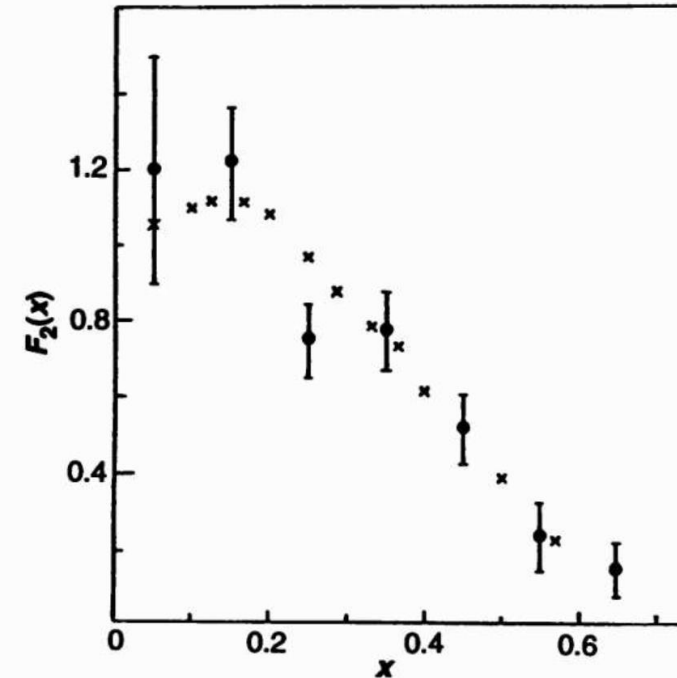
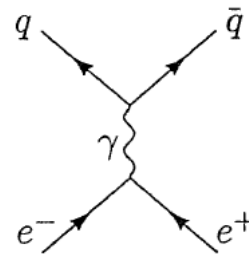
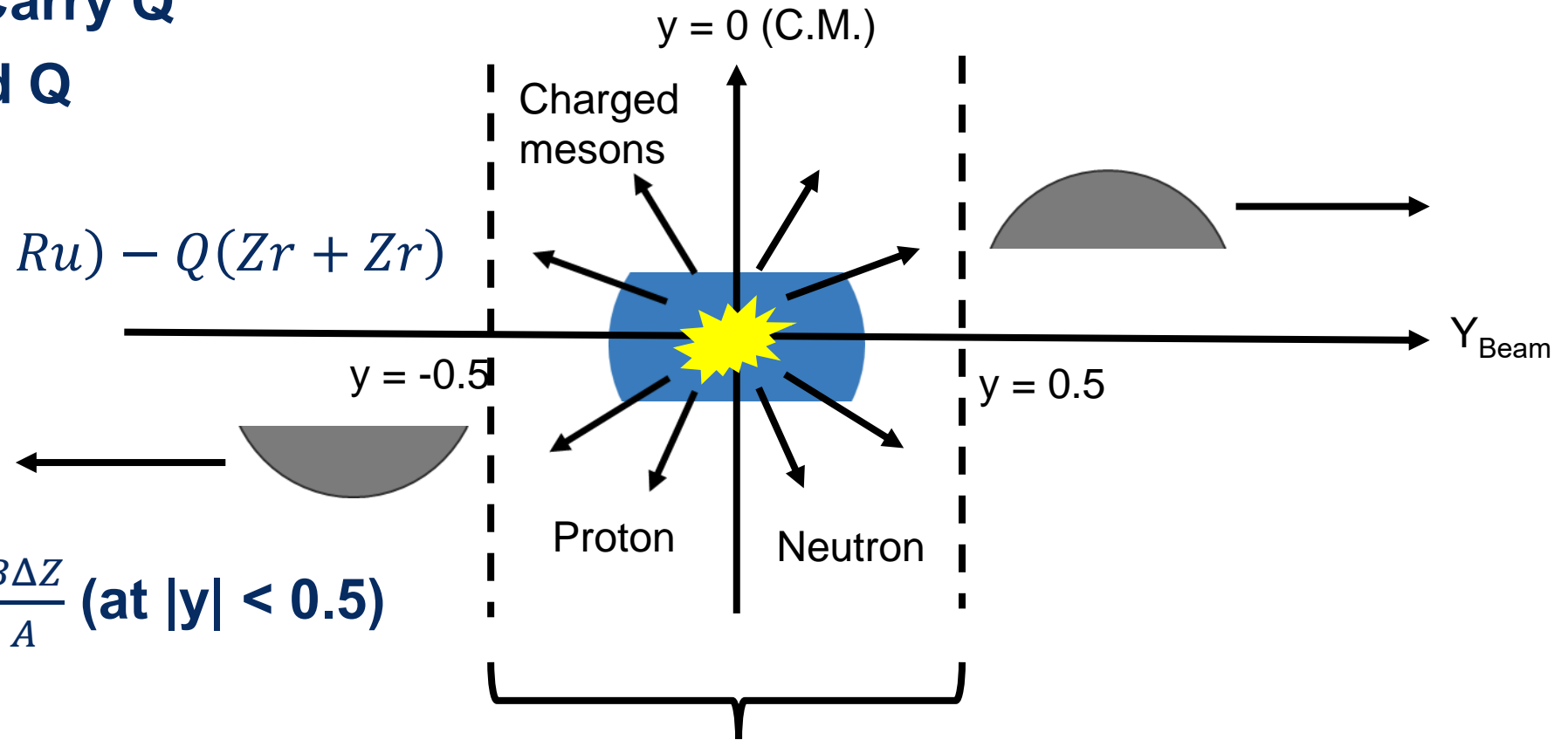

Fig. 8. Comparison of structure functions measured in deep inelastic neutrino-nucleon scattering experiments on the Gargamelle heavy-liquid bubble chamber with the MIT-SLAC data [(●), Gargamelle, $F_2^{\nu N}$; (×), MIT-SLAC, $(18/5)F_2^{eN}$]. When multiplied by 18/5, a number specified by the quark-parton model, the electron scattering data coincide with the neutrino data.

M. E. Peskin, D. V. Schroeder, *An Introduction to Quantum Field Theory*, Addison-Wesley Publishing Company, 1995

Method 1: Net-Baryon (B) vs. Net-Charge (Q)

- **Charged mesons: Carry Q**
- **Proton: Carry B and Q**
- **Neutron: Carry B**
- **Define $\Delta Q = Q(Ru + Ru) - Q(Zr + Zr)$**



- **Question: $\Delta Q = ??? \frac{B\Delta Z}{A}$ (at $|y| < 0.5$)**

- $B = (N_p - N_{\bar{p}}) + (N_n - N_{\bar{n}})$
- $Q = (N_{\pi^+} + N_{K^+} + N_p) - (N_{\pi^-} + N_{K^-} + N_{\bar{p}})$



Expected values of $B/\Delta Q * \Delta Z/A$ for different carriers

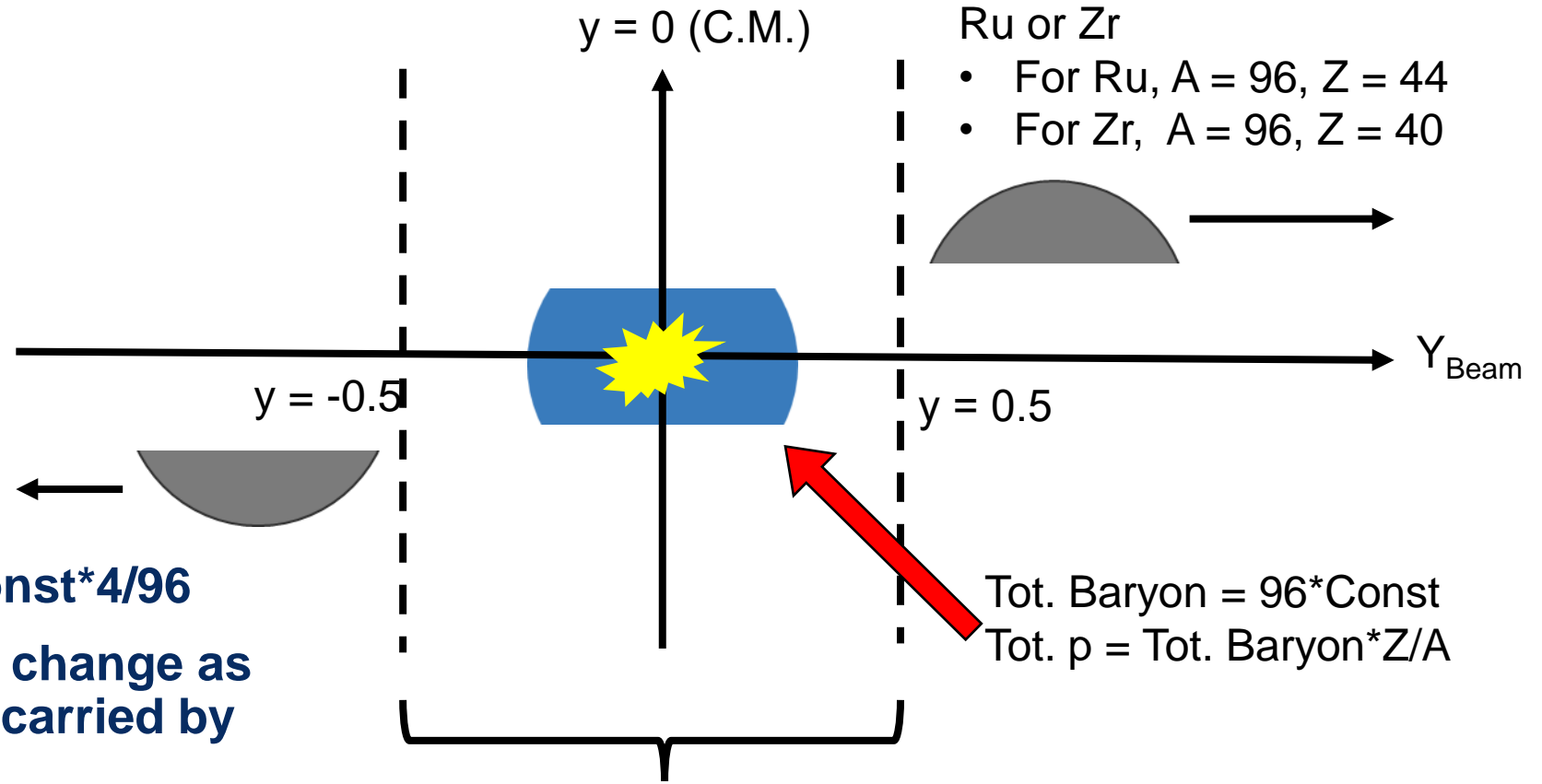
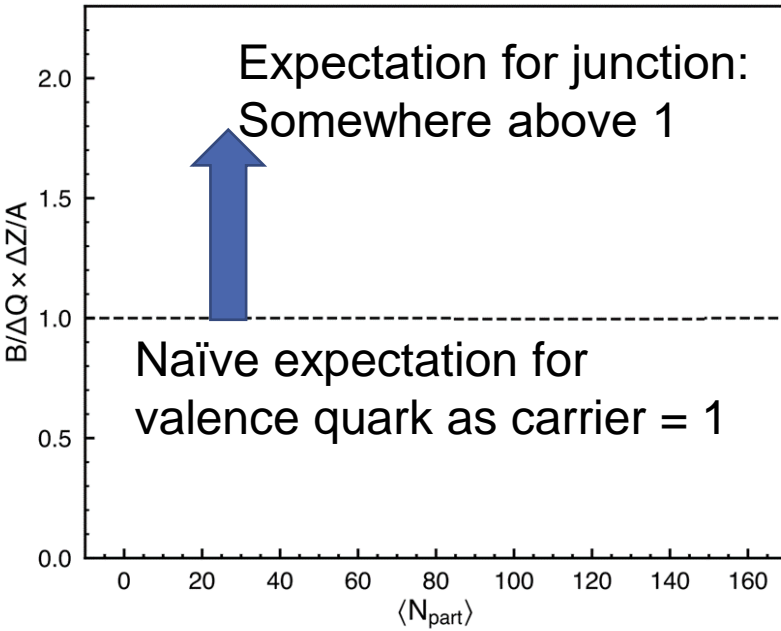

- $B_{init} = 96 * Const$
- $\Delta Q_{init} = Q_{init} (Ru - Zr) = 96 * Const * 4/96$
- $(B/\Delta Q * \Delta Z/A)_{init} = 1$, should not change as partons evolve if B and Q are carried by valence quarks.
- For junction, B is enhanced so $B/\Delta Q * \Delta Z/A > 1$

$$B = (N_p - N_{\bar{p}}) + (N_n - N_{\bar{n}})$$

$$Q = (N_{\pi^+} + N_{K^+} + N_p) - (N_{\pi^-} + N_{K^-} + N_{\bar{p}})$$



Net-Baryon number (B) and net-Charge (Q)

- $B = (N_p - N_{\bar{p}}) + (N_n - N_{\bar{n}})$
- (Anti-)Neutron yields are estimated with thermal model assumption
- $B = (N_p - N_{\bar{p}}) + N_{\bar{p}} \sqrt{\frac{N_d}{N_{\bar{d}}}} - N_p \sqrt{\frac{N_{\bar{d}}}{N_d}}$
- $\Delta Q = \left[(N_{\pi^+} + N_{K^+} + N_p) - (N_{\pi^-} + N_{K^-} + N_{\bar{p}}) \right]_{Ru} - \left[\right]_{Zr}$,
- Define $R2_{\pi} = \frac{(N_{\pi^+}/N_{\pi^-})_{Ru}}{(N_{\pi^+}/N_{\pi^-})_{Zr}}$,
- Let $N_{\pi} = 0.5 \times (N_{\pi^+} + N_{\pi^-})$, then change of variable,
- $\Delta Q \approx N_{\pi}(R2_{\pi} - 1) + N_K(R2_K - 1) + N_p(R2_p - 1)$
- Systematic uncertainty is reduced by replacing difference of spectrum with product of spectrum and double ratio where uncertainty cancels out

$$\begin{aligned} N_d &= F(m_d, T) \exp(2\mu_B + \mu_Q) \\ N_{\bar{d}} &= F(m_d, T) \exp(-2\mu_B - \mu_Q) \\ N_p &= F(m_p, T) \exp(\mu_B + \mu_Q) \\ N_{\bar{p}} &= F(m_p, T) \exp(-\mu_B - \mu_Q) \\ N_n &= F(m_n \approx m_p, T) \exp(\mu_B) \end{aligned}$$

Therefore,

$$\begin{aligned} \frac{N_d}{N_p^2} &= \frac{F(m_d, T)}{F(m_p, T)^2} \exp(-\mu_Q) \\ \frac{N_{\bar{d}}}{N_{\bar{p}}^2} &= \frac{F(m_d, T)}{F(m_p, T)^2} \exp(\mu_Q) \\ \frac{N_n}{N_p} &= \exp(-\mu_Q) \end{aligned}$$

Therefore,

$$\frac{N_n}{N_p} = \sqrt{\frac{d/p^2}{\bar{d}/\bar{p}^2}} = \frac{\bar{p}}{p} \sqrt{\frac{d}{\bar{d}}}$$

STAR Collaboration, PRC 99, 064905 (2019)

STAR detector

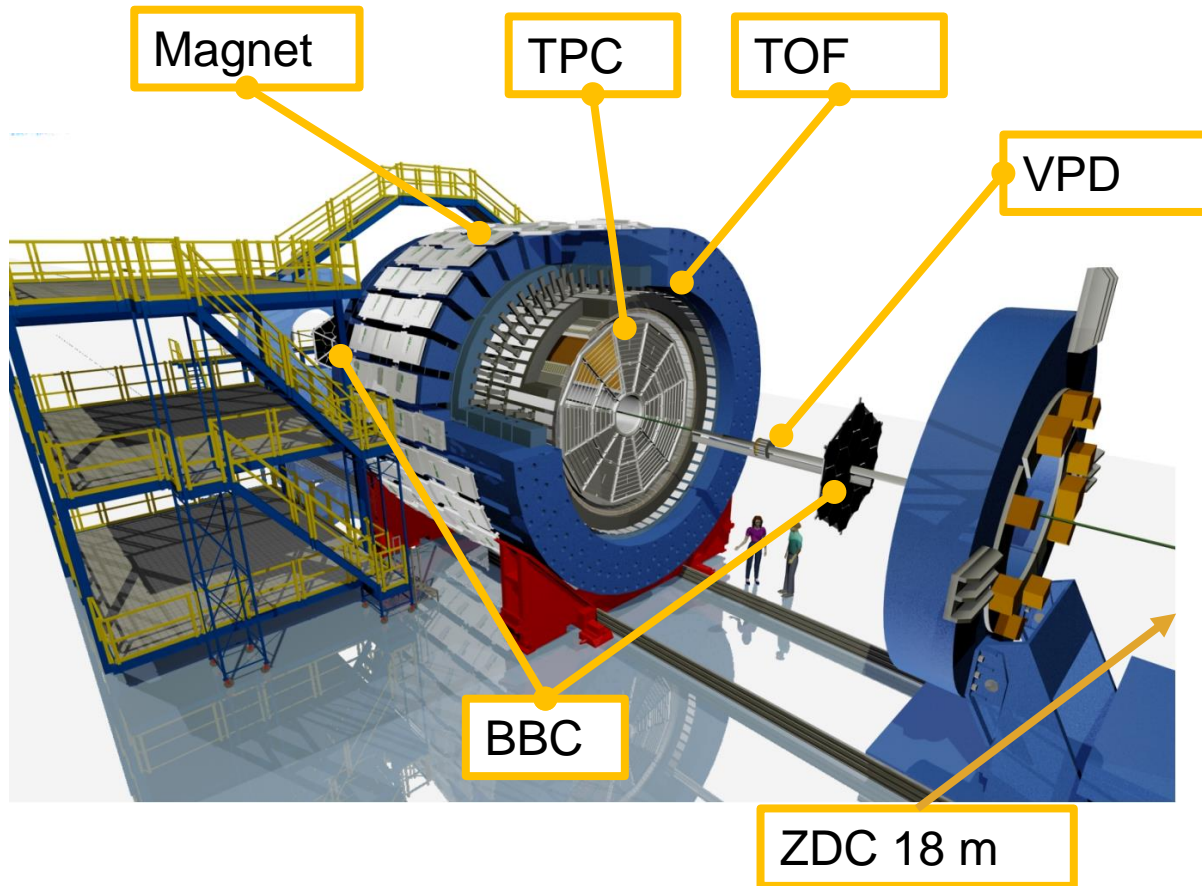

- **Time Projection Chamber (TPC)**
 - Measures charged particle momentum with track curvature under B-field
 - Identifies particle with energy loss per unit length (dE/dx)
- **Time-Of-Flight (TOF)**
 - Extends momentum range for particle identification
 - Pile-up rejection
- **Zero Degree Calorimeter (ZDC)**
 - Detect forward neutrons for event selection
- **Beam-Beam counter (BBC)**
 - Detector forward and backward beam fragments
- **Vertex Position Detector (VPD)**
 - One on the east and one on the west.
 - Vertex location is calculated from the averaged time of particle detection on both sides.

Spectra from Isobar Collisions

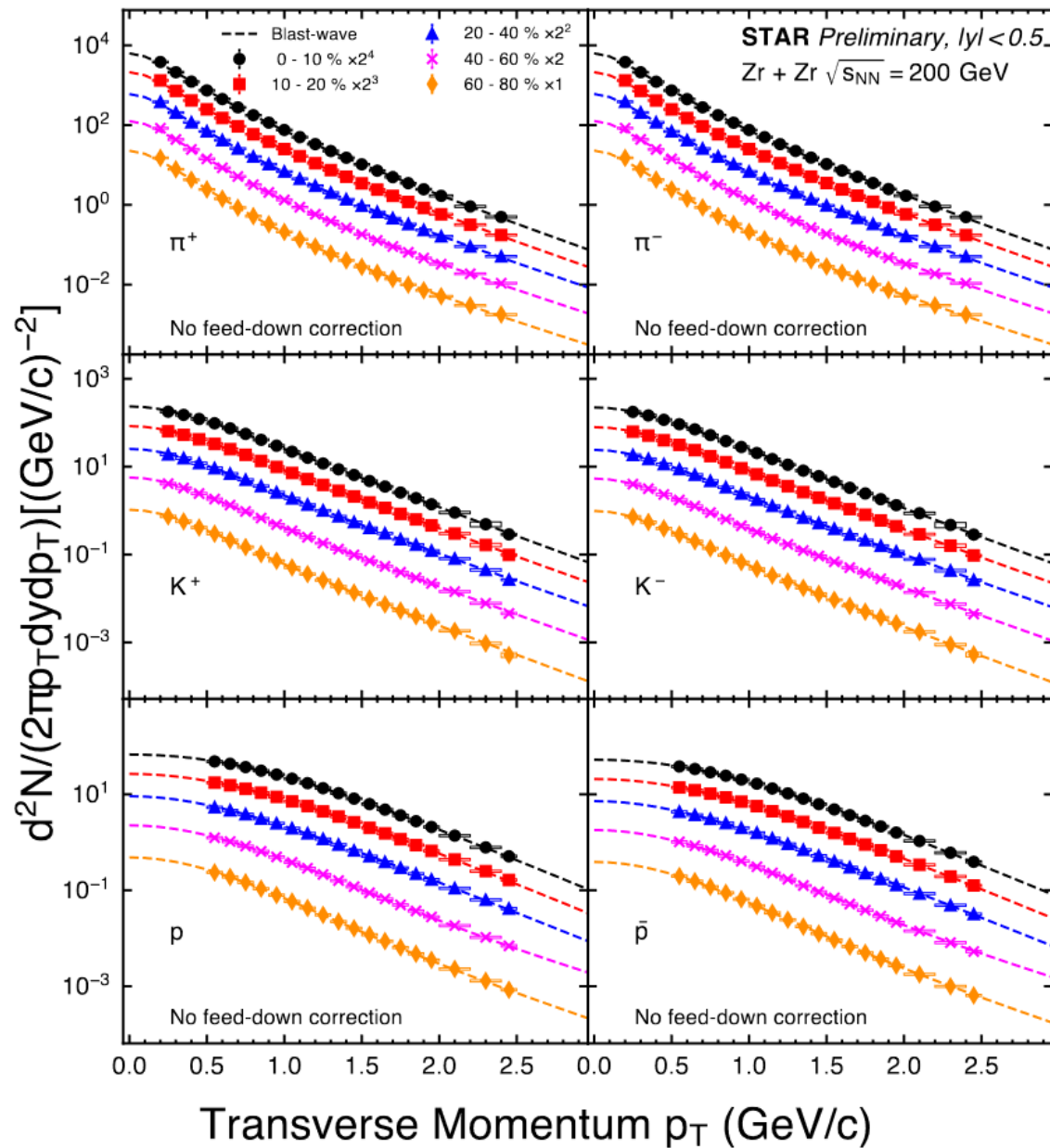
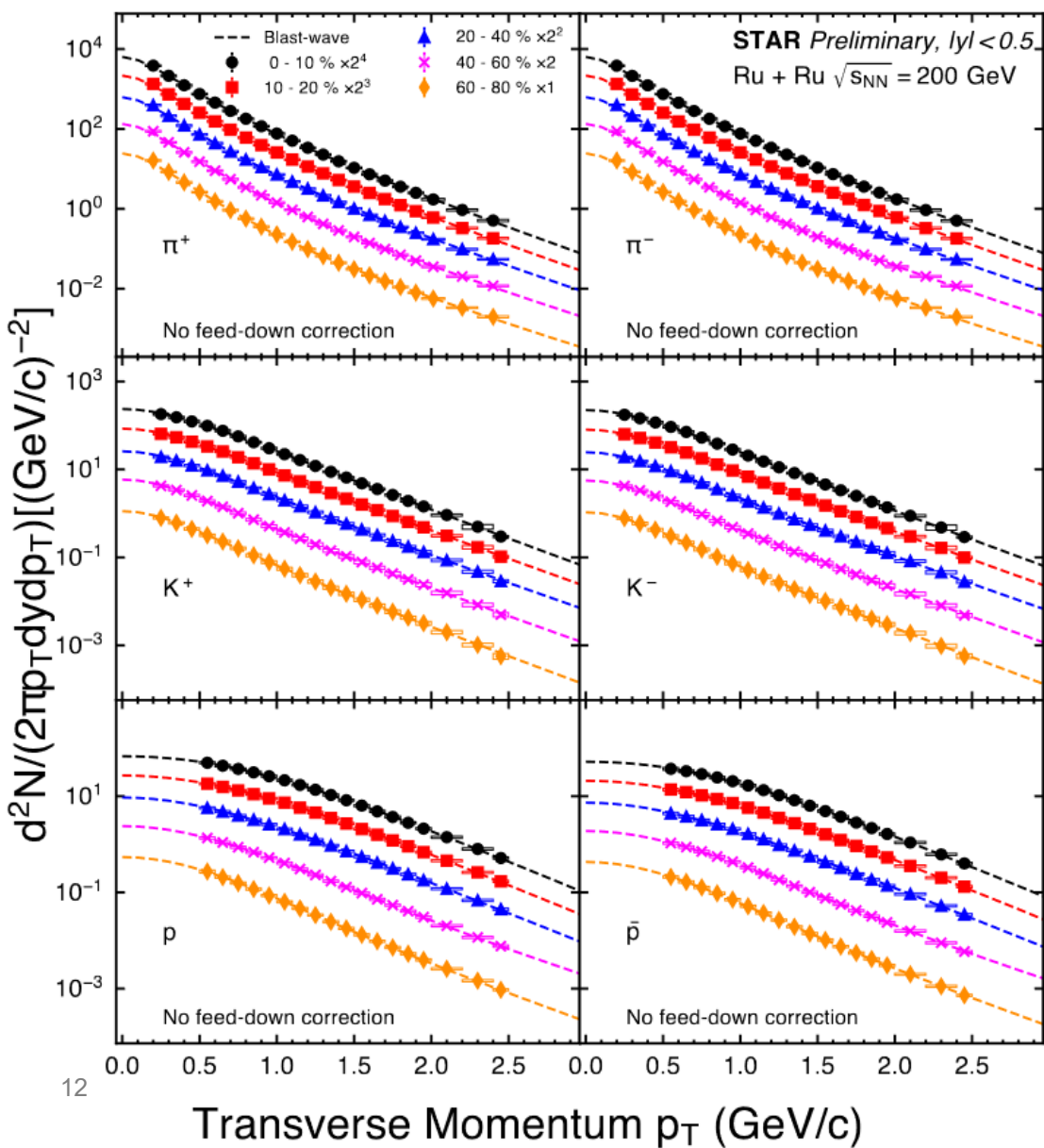
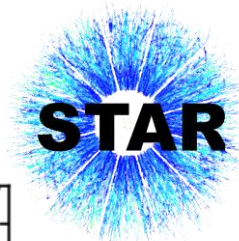

Double ratio R2s

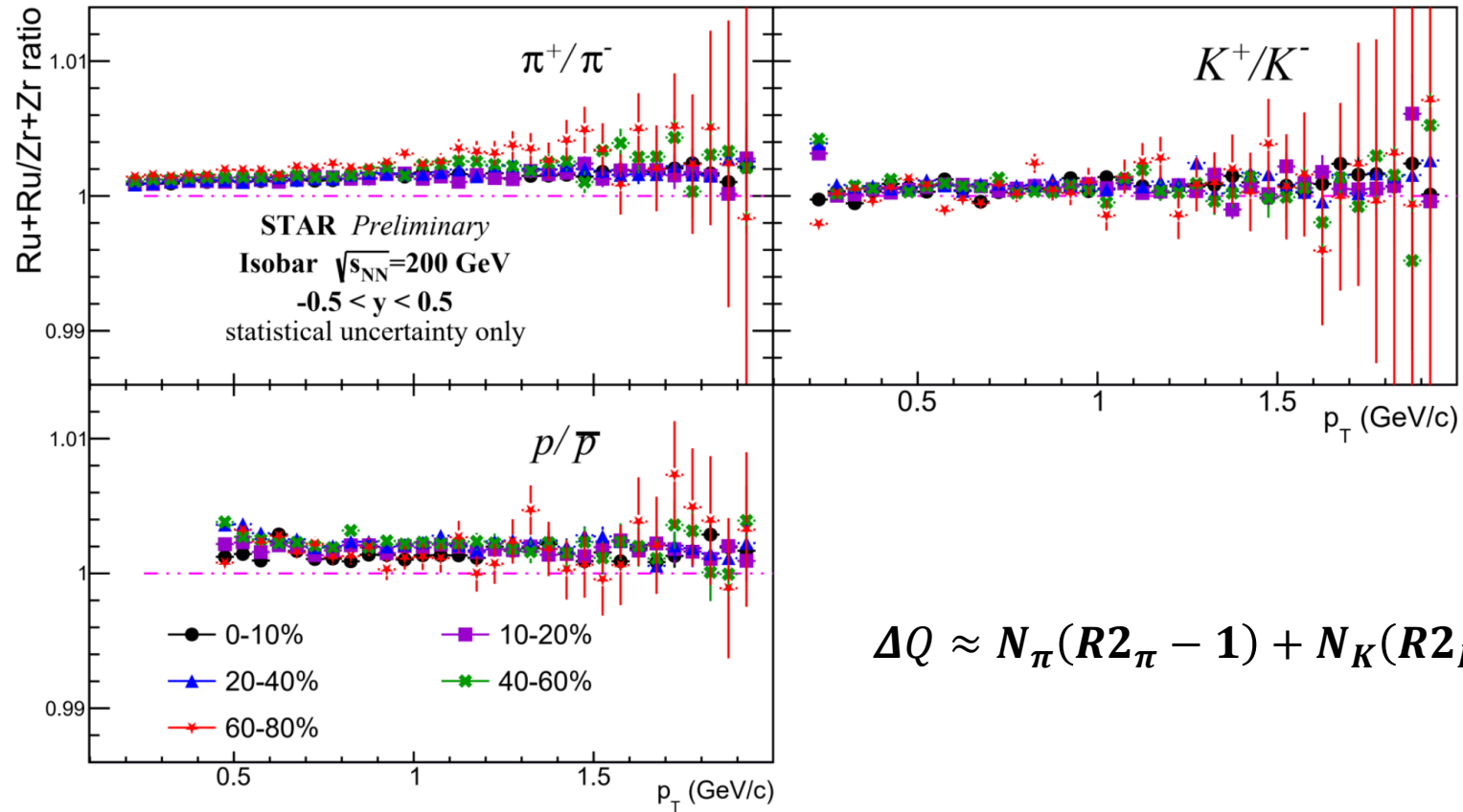

$$\Delta Q \approx N_\pi(R2_\pi - 1) + N_K(R2_K - 1) + N_p(R2_p - 1)$$

Net-Charge and Net-Baryon compared to UrQMD separately

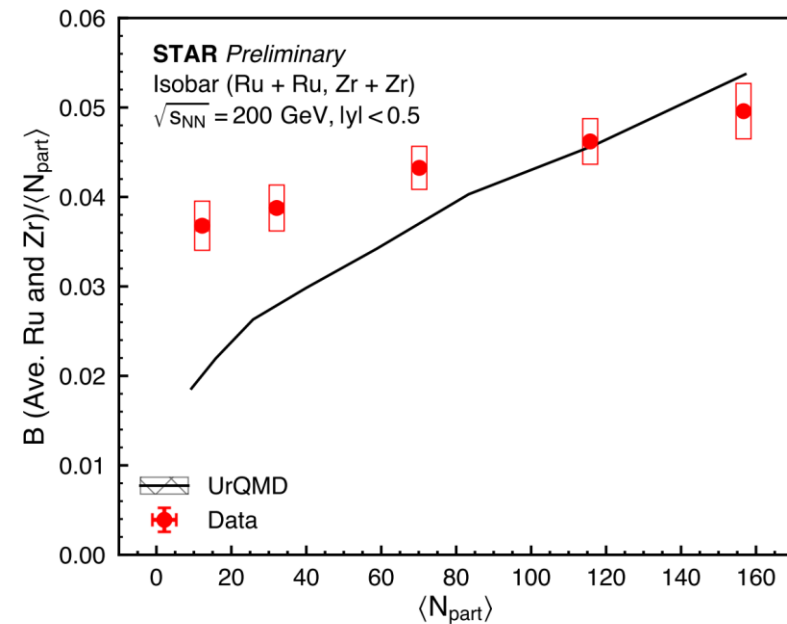
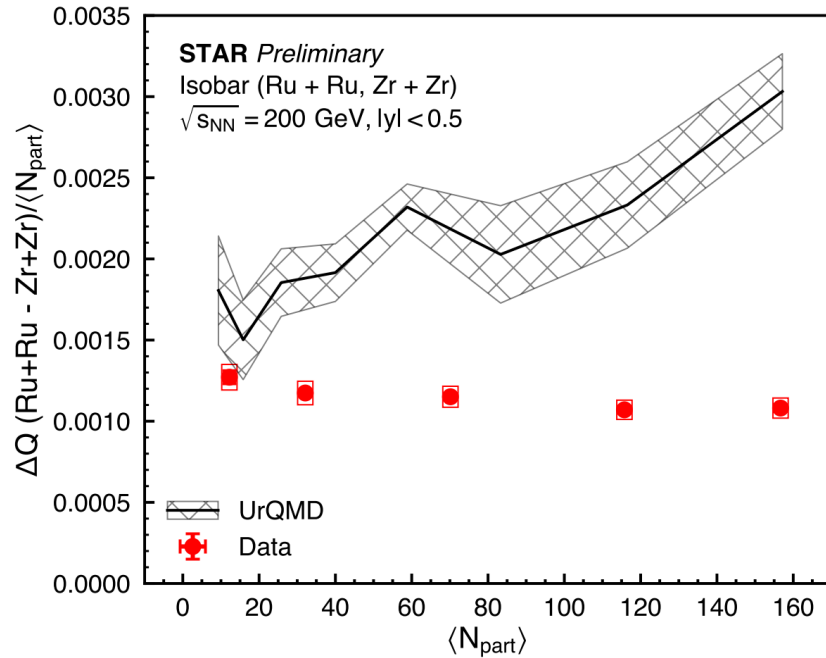

- **UrQMD accurately reproduces baryon transport to mid-rapidity in central collisions but not ΔQ , probably because UrQMD has been tuned to net-proton measurements**
- **Accurate measurement of charge transport can be used for model tuning**



Experimental result on Net-Charge and Net-Baryon

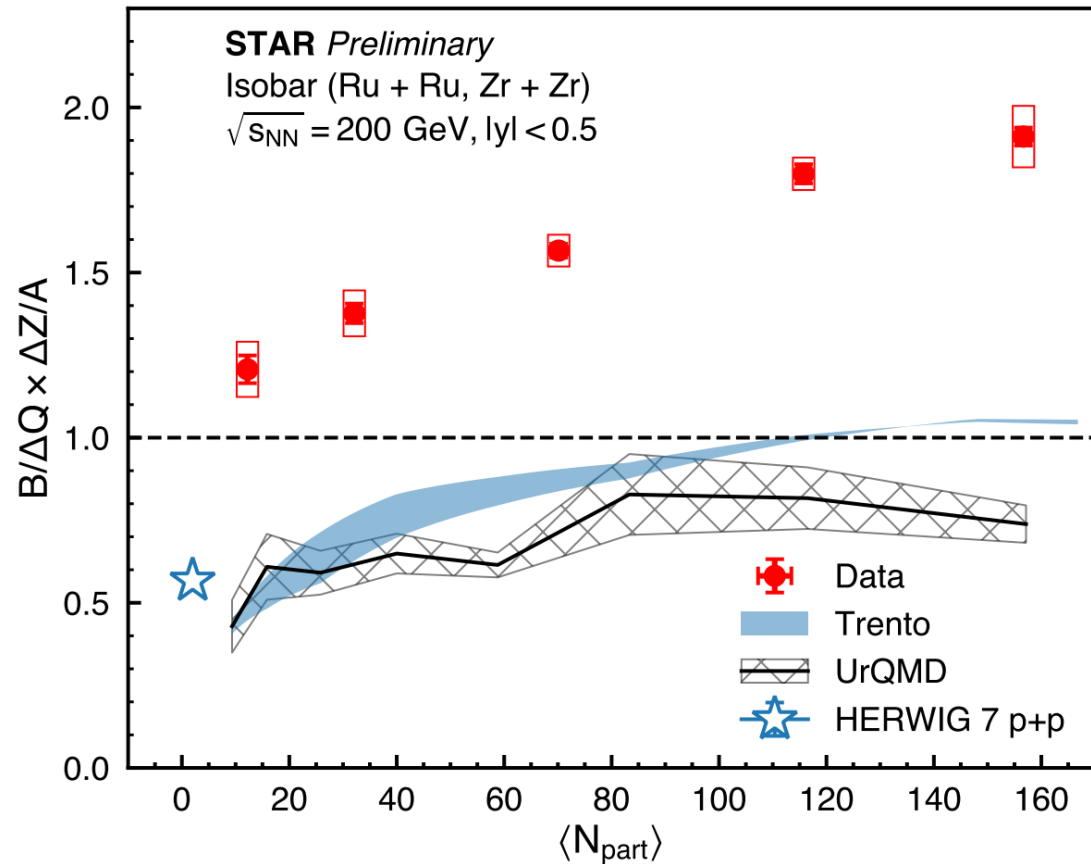

- $B/\Delta Q * \Delta Z/A > 1$
- Model calculations (Herwig $p + p$ ($B/Q * Z/A$, $Z=A=1$) [1] and UrQMD [2]) cannot describe our data
- Decrease with decreasing $\langle N_{part} \rangle$
 - Similar trend seen in Trento model [3]
 - Trento model accounts for initial conditions only
 - Consistent with change in neutron skin thickness differences

[1]: J. Bellm et al, Eur. Phys. J.C. 80 5, 452 (2020)

[2]: M. Bleicher et al, J. Phys. G. 25, 1859 (1999)

[3]: H. Xu et al, PRC 105, L011901 (2022)



Baryon transport from junction

- **Three methods to test the hypothesis:**
 1. Net-Baryon vs. Net-Electric charge in Isobar collisions
 2. **Net-Baryon in photonuclear collisions**
 3. Net-proton yield as a function of rapidity in hadronic Au+Au collisions

Method 2: Net-Baryon in photonuclear collisions

If junction hypothesis is true:

- Quasi-real $\gamma \rightarrow q\bar{q}$
- Interact with a junction in target Au nucleus
- Enhanced creation of mid-rapidity baryons
 - Junction interaction time > quark interaction time
 - More baryons are stopped in junction picture
- Regge theory: $dN/dy \propto e^{-\alpha_B \delta y}$, where
 - α_B is related to Regge intercept of junctions (J. D. Brandenburg, N. Lewis, P. Tribedy, Z. Xu, arXiv:2205.05685 (2022)).

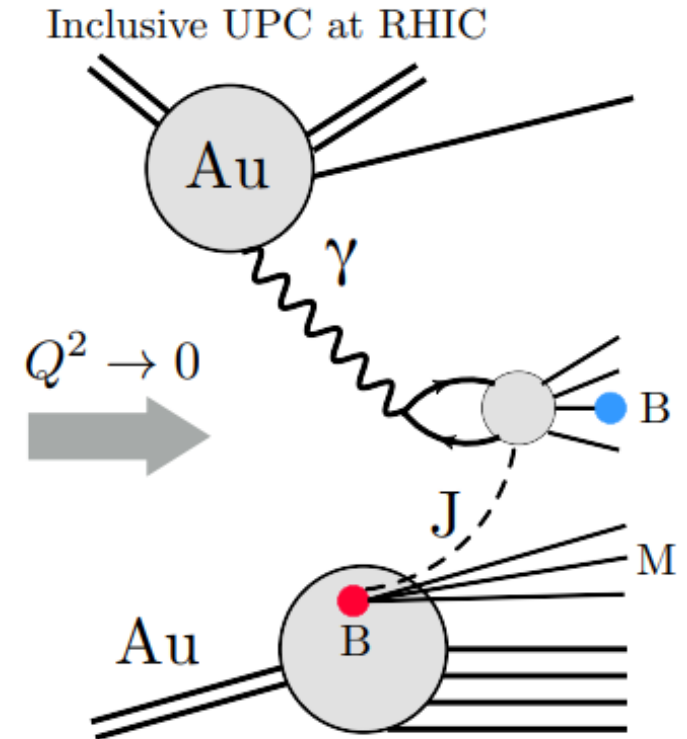

Figure from J. D. Brandenburg, N. Lewis, P. Tribedy, Z. Xu, arXiv:2205.05685 (2022)



Selecting photonuclear events in Au + Au collisions at $\sqrt{s_{NN}} = 54.4$ GeV

- **Asymmetric collision: target can only be traveling in one direction**
- **Select events with,**
 - Single neutron (1n) on ZDC east (ZDCE)
 - No activity in BBC east
 - Multiple neutron (Xn) on ZDC west (ZDCW)
 - Activity in BBC west
 - $|V_z(\text{VPD}) - V_z(\text{TPC})| > 10$ cm
 - vice versa (east \leftrightarrow west)

Figures from J. D. Brandenburg, N. Lewis, P. Tribedy, Z. Xu, arXiv:2205.05685 (2022)

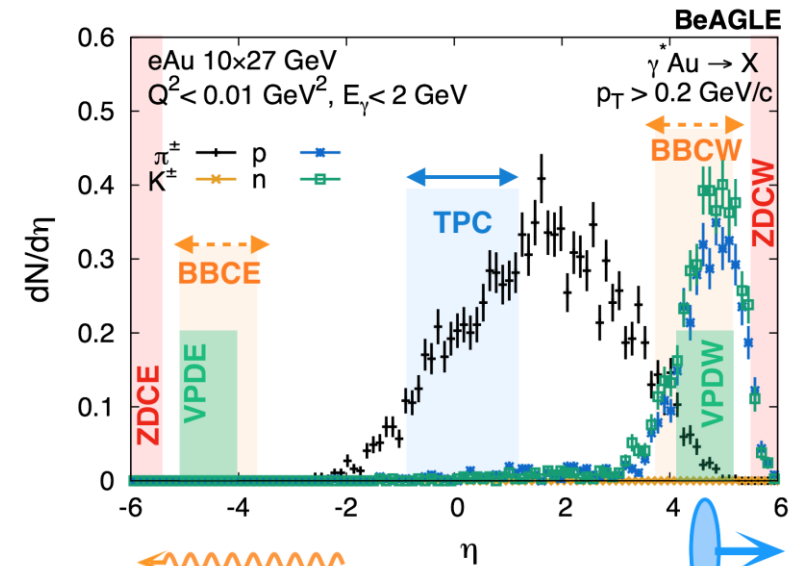
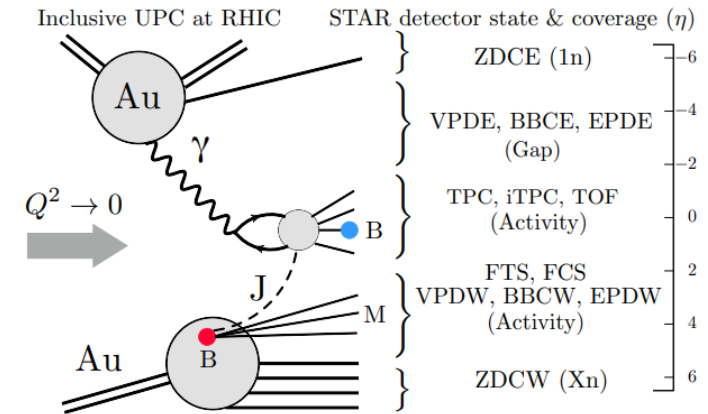

BeAGLE: W. Wang, *et al* PRD **106**, 012007 (2022)



Net-proton yield as a proxy for Net-Baryon

- Net-proton yield is described by $\exp((1.13 \pm 0.32)y) = \exp(-(1.13 \pm 0.32)\delta y)$
 - Recall that $\delta y = y_{beam} - y$ and $y_{beam} = 0$ in C.M. frame.
- PYTHIA-6, which has valence quarks as baryon number carrier, predicts a dependence of $\exp(-2.43\delta y)$ [1, 2, 3]

[1]: J. D. Brandenburg, N. Lewis, P. Tribedy, Z. Xu, arXiv:2205.05685 (2022)
[2]: B. Andersson, G. Gustafson, G. Ingelman, and T. Sjöstrand, Physics Reports 97, 31–145 (1983).
[3]: Torbjorn Sjostrand, Stephen Mrenna, and Peter Z. Skands, JHEP 05, 026 (2006), arXiv:hep-ph/0603175.

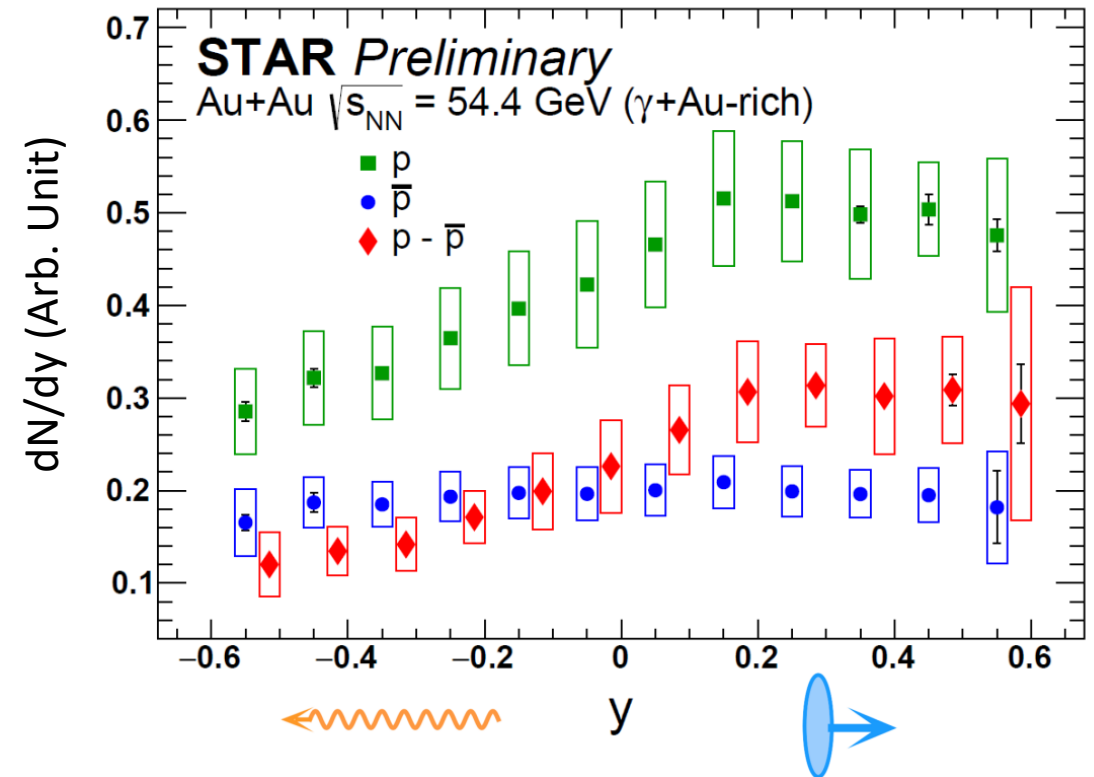



Baryon transport from junction

- **Three methods to test the hypothesis:**
 1. Net-Baryon vs. Net-Electric charge in Isobar collisions
 2. Net-Baryon in photonuclear collisions
 3. **Net-proton yield as a function of rapidity in hadronic Au+Au collisions**



Method 3: Net-proton yield at mid-rapidity as a function of beam rapidity in hadronic Au+Au collisions

- Regge theory predicts $dN/dy|_{y=0} \propto e^{-a_B \delta y}$
- Measured $a_B \approx 0.65$
- Slope is too small (flat) to be explained by conventional model such as PYTHIA and HERWIG (see next slide)
- Slope does not depend on centrality
 - Valence quark transport is expected to depend on multiple scatterings and thus on centrality

Au + Au BES-I data
STAR, PRC **79**, 034909 (2009) and
STAR, PRC **96**, 044904 (2017)

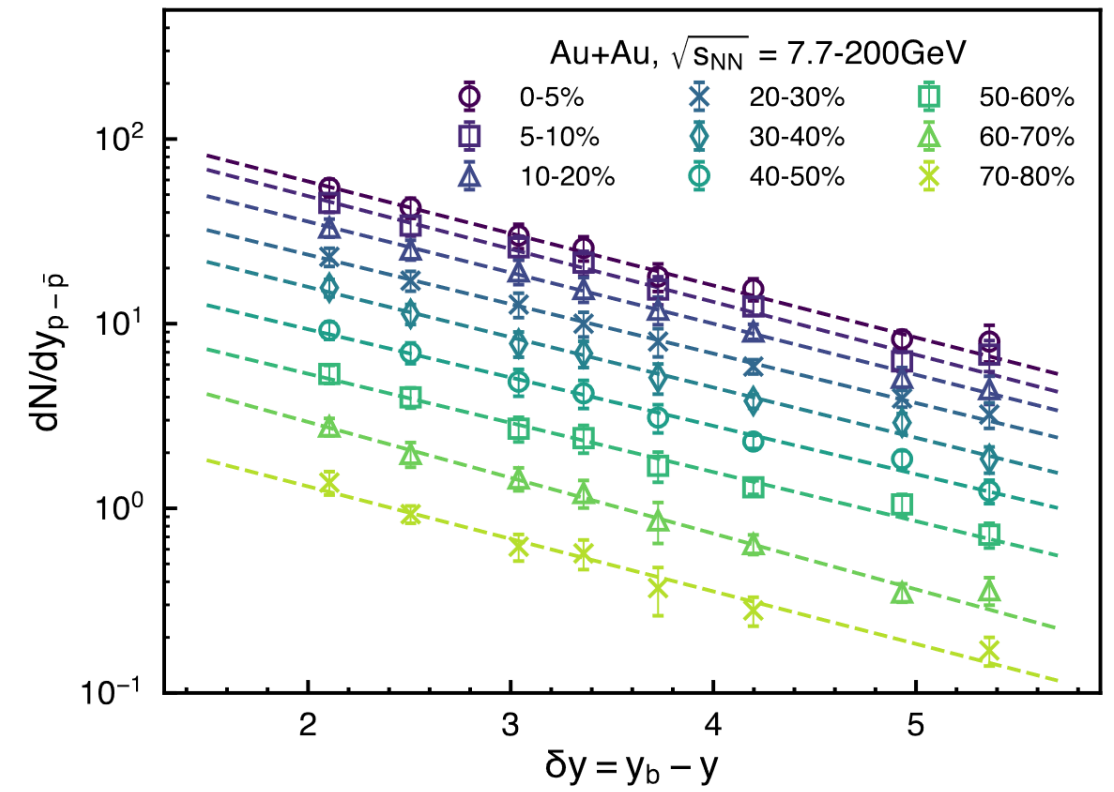

Net-proton exponential slope (α_B)

- $\alpha_B \sim 0.6$ for Au+Au [1, 2]
- $\alpha_B \sim 1$ for $\gamma + Au$
- Predicted values from HERWIG and PYTHIA (both versions) disagree with data
 - PYTHIA 8 includes a junction-like mechanism in final-state hadronization [3]
- Slopes for Junction-Junction (J+J) and Junction-Pomeron (J+P) predictions are more compatible with data [4]

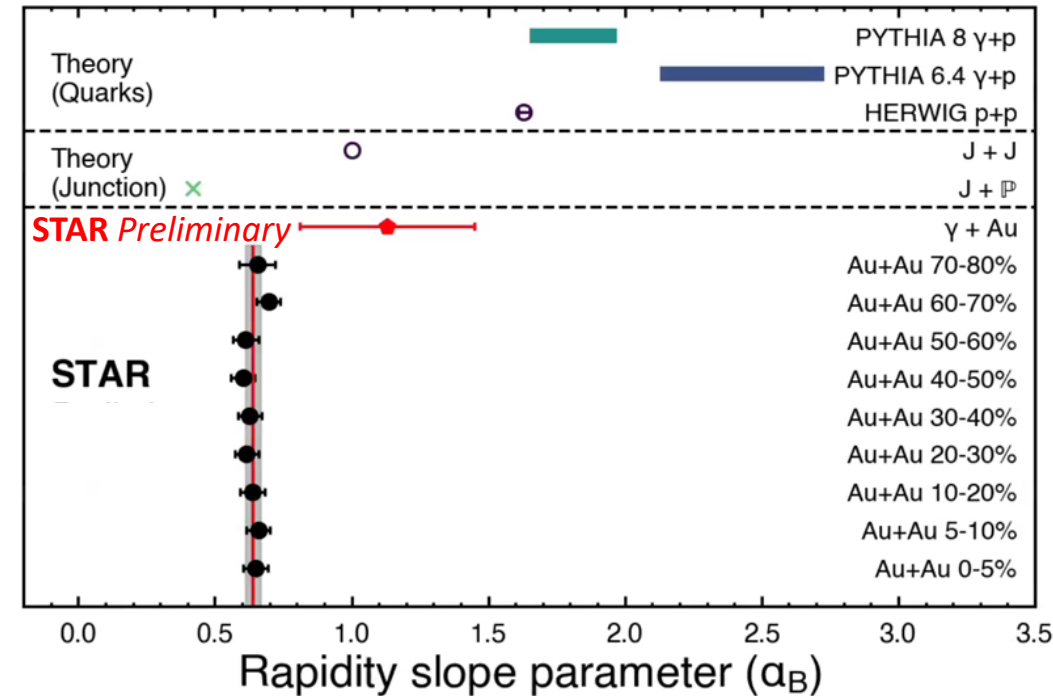

[1] STAR, PRC **79**, 034909 (2009)

[2] STAR, PRC **96**, 044904 (2017)

[3] Christiansen, J. R. & Skands, P. Z. String Formation Beyond Leading Colour. JHEP 08, 003 (2015). 1505.01681.

[4] Kharzeev, D. Can gluons trace baryon number? Phys. Lett. B 378, 238–246 (1996).nucl-th/9602027.

Need for forward detector: Cover a wider range of rapidity loss $\delta y = y_{beam} - y$ at different beam energy

- Near y_{beam} , slope may change due to contribution from next to leading term.

- Net baryon disagrees with low energy at 200 GeV. What happens at higher energy?

- Data from wide rapidity range to understand these contributions.

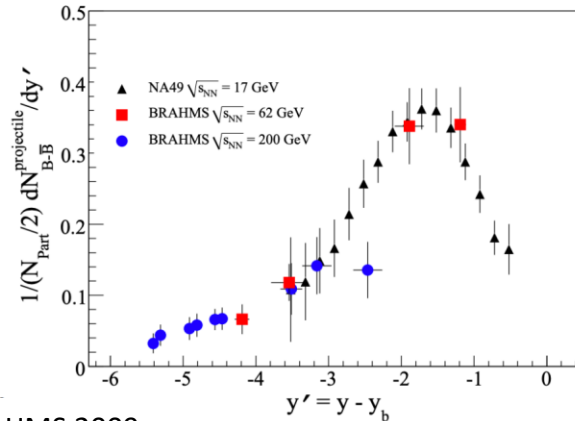

BRAHMS 2009

Figure 5: Projectile net-baryon rapidity density $(1/N_{part}/2)dN_{B-B}^{projectile}/dy'$ from SPS and RHIC after subtraction of the target net-baryon contribution (see Fig. 4).

Poster by Adrien Florio, David Frenklakh and Dmitri Kharzeev, QM 2023



Chun Yuen Tsang, Forward Physics in ALICE 3

A new idea: can we study junctions in ep-collisions? Yes!

- Tag a baryon in the virtual photon fragmentation region.
- Junction goes forward along with 2, 1 or 0 valence quarks (as shown on Fig. 4a-6a).
- The rest of the valence quarks break away from the junction producing unobserved mesons.
- The asymptotic s -dependence of the cross-sections estimated using optical theorem and Regge theory:

$$\sigma \propto s^{\alpha(0)-1}$$
 where $\alpha(0)$ is the intercept of the state exchanged in the t -channel of squared diagram.
- For the states M_4^J, M_2^J, M_0^J (shown on Fig. 4b-6b) the intercepts are estimated as [3]:

$$\alpha_{2k}^J = 2\alpha_B(0) - 1 + (3-k)(1 - \alpha_R(0))$$
 for $k=0, 1, 2$. $\alpha_B(0)$ and $\alpha_R(0)$ are the baryon and reggeon intercepts respectively.
- M_0^J has the largest intercept so the corresponding process dominates at large s .
- Rapidity dependence estimated (see Fig. 7)

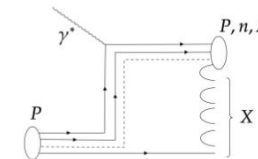

Fig. 4a The junction and two valence quarks in the forward direction. One string breaks producing unobserved mesons.

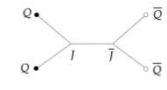

Fig. 4b M_4^J state exchanged in the t -channel of squared amplitude of Fig. 4a. $\alpha_4^J \approx -\frac{1}{2}$

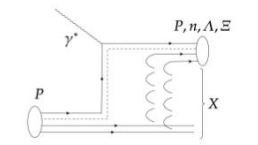

Fig. 5a The junction and one valence quark in the forward direction. Two strings break producing unobserved X.

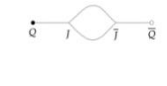

Fig. 5b M_2^J state exchanged in the t -channel of squared amplitude of Fig. 5a. $\alpha_2^J \approx 0$

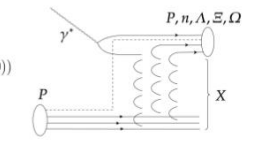

Fig. 6a Only the junction without valence quarks in the forward direction. Three strings break producing unobserved X.



Fig. 6b M_0^J state exchanged in the t -channel of squared amplitude of Fig. 6a. $\alpha_0^J \approx \frac{1}{2}$

- Flavor-independent forward baryon production rate since no valence quarks remain with the junction
- Large flavor-independent meson multiplicity
- Characteristic rapidity dependence (see Figure 7), decreasing in the forward direction slower than naively expected

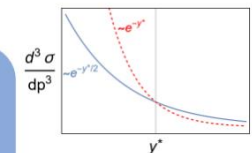
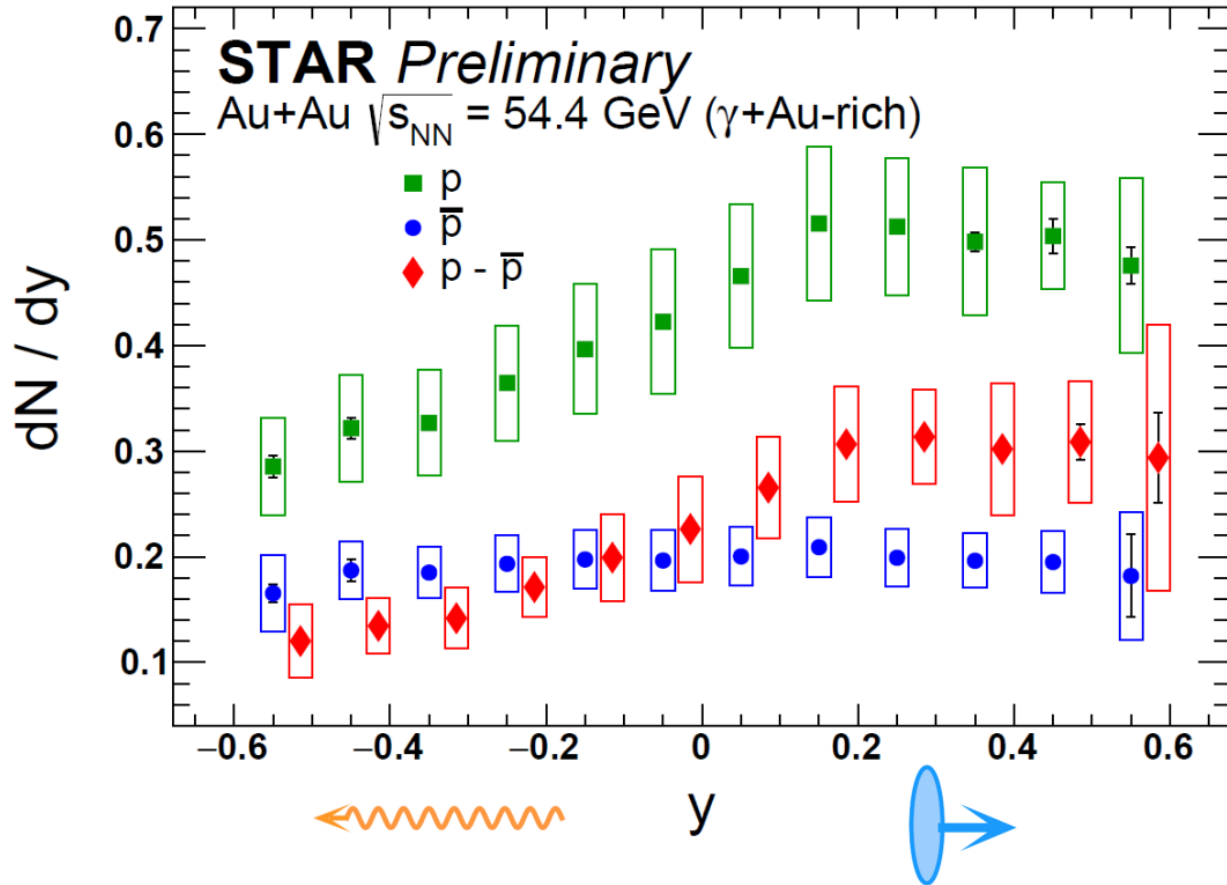

Fig. 7 Differential cross-section as a function of produced baryon COM rapidity y^* . Solid blue line: leading M_0^J exchange. Dashed red: subleading exchange or a naive expectation with baryon exchange.



Need for forward detector: Net-proton yield in photonuclear collision at forward rapidity



- STAR measures the slope at mid-rapidity.
- UPC corresponds to collision at lower CM energy.
- Will we see a change in exponential slope when y approaches y_{beam} , like for A + A collision?
- Study sub-leading contribution.



Conclusion

- Exponential slope of mid-rapidity net-proton yield in hadronic Au+Au from BES-I < theoretical (PYTHIA/HERWIG) predictions
- Observed significant net-proton yield $\gamma + Au$ collisions, whose slope against rapidity is smaller than that from PYTHIA and HERWIG without baryon junction
- The observed ratio of baryon to charge number difference is > 1 and models without baryon junction predications are < 1 with Ru+Ru and Zr+Zr collisions at $\sqrt{s_{NN}} = 200$ GeV
- Our results disfavor the assertion that valence quarks carry the baryon number

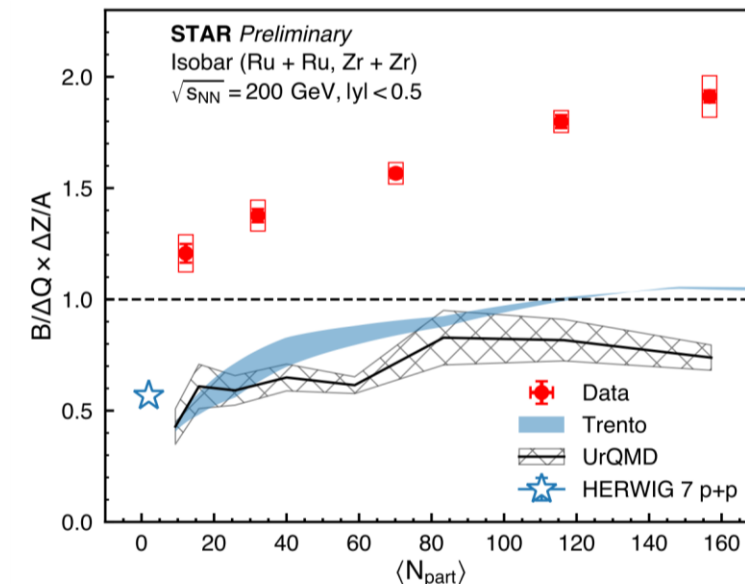
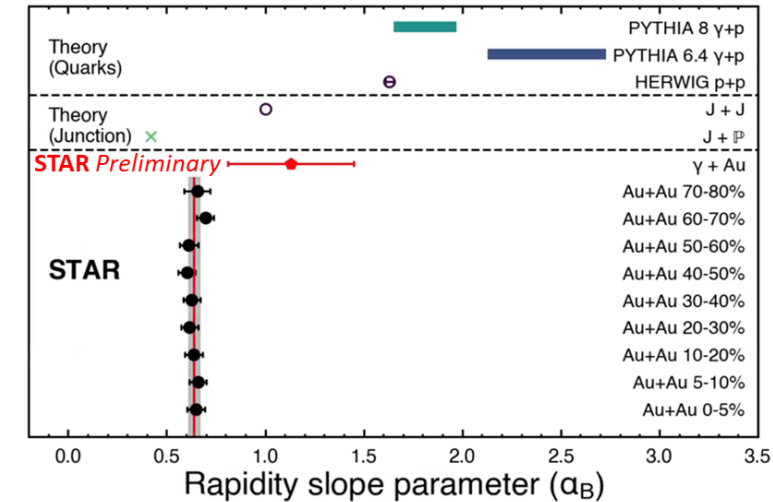

Thanks

Backup slides



Net-Charge difference (Ru+Ru – Zr+Zr)

- Define $R2_{\pi} = \frac{(N_{\pi}^{+}/N_{\pi}^{-})_{Ru}}{(N_{\pi}^{+}/N_{\pi}^{-})_{Zr}}$,
- Define $\Delta Q = [(N_{\pi}^{+} + N_K^{+} + N_p) - (N_{\pi}^{-} + N_K^{-} + N_{\bar{p}})]_{Ru} - []_{Zr}$,
- $R2_{\pi} = \frac{(N_{\pi}^{+}/N_{\pi}^{-})_{Ru}}{(N_{\pi}^{+}/N_{\pi}^{-})_{Zr}} \approx \frac{[1+(N_{\pi}^{+}-N_{\pi}^{-})/N_{\pi}]_{Ru}}{[1+(N_{\pi}^{+}-N_{\pi}^{-})/N_{\pi}]_{Zr}} = \frac{1+\Delta R_{Ru}}{1+\Delta R_{Zr}} \approx 1 + \Delta R_{Ru} - \Delta R_{Zr}$
- Focus on pion terms,
- $(N_{\pi}^{+} - N_{\pi}^{-})_{Ru} - (N_{\pi}^{+} - N_{\pi}^{-})_{Zr} = N_{\pi,Ru} \times \Delta R_{Ru} - N_{\pi,Zr} \times \Delta R_{Zr}$
- $\approx N_{\pi}(\Delta R_{Ru} - \Delta R_{Zr}) = N_{\pi} \times (R2_{\pi} - 1)$
- Where $N_{\pi} = 0.5 \times (N_{\pi}^{+} + N_{\pi}^{-})$
- Therefore, $\Delta Q = N_{\pi}(R2_{\pi} - 1) + N_K(R2_K - 1) + N_p(R2_p - 1)$
- Double ratio reduces systematics uncertainty

Method 3: Net-Baryon in photonuclear collisions

- Inclusive particle production in photonuclear collisions**

- Large flux of quasi-real photons produced by ultra-relativistic large-Z nuclei
- Similar to eA collisions except that the photon has almost zero virtuality
- Probes the nucleus at low- x

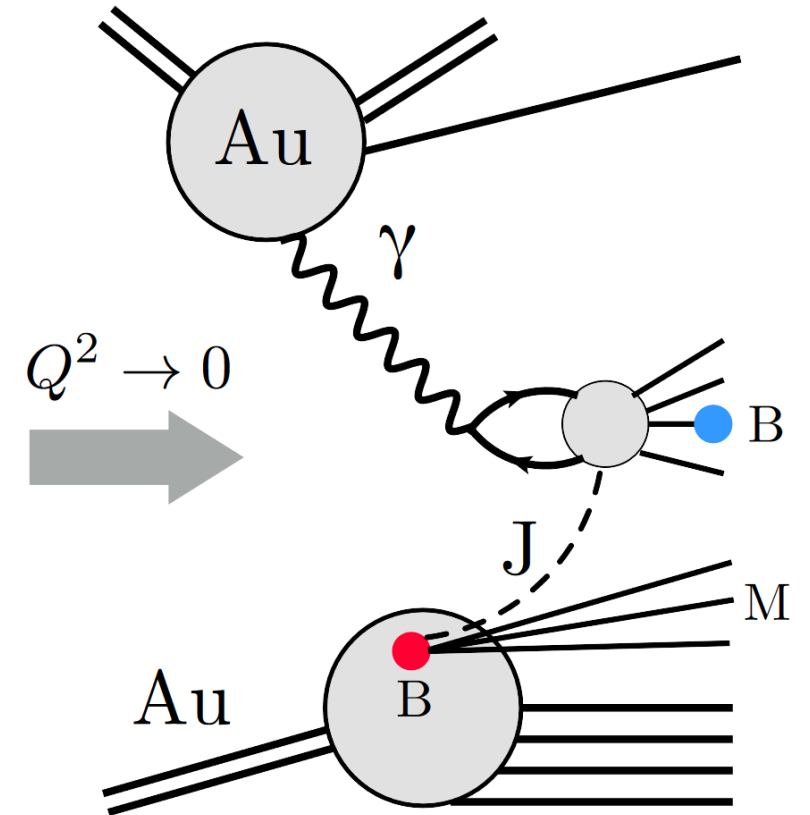

J. D. Brandenburg, N. Lewis,
P. Tribedy, Z. Xu, arXiv:2205.05685
(2022)

Rapidity asymmetry in γ A-rich events

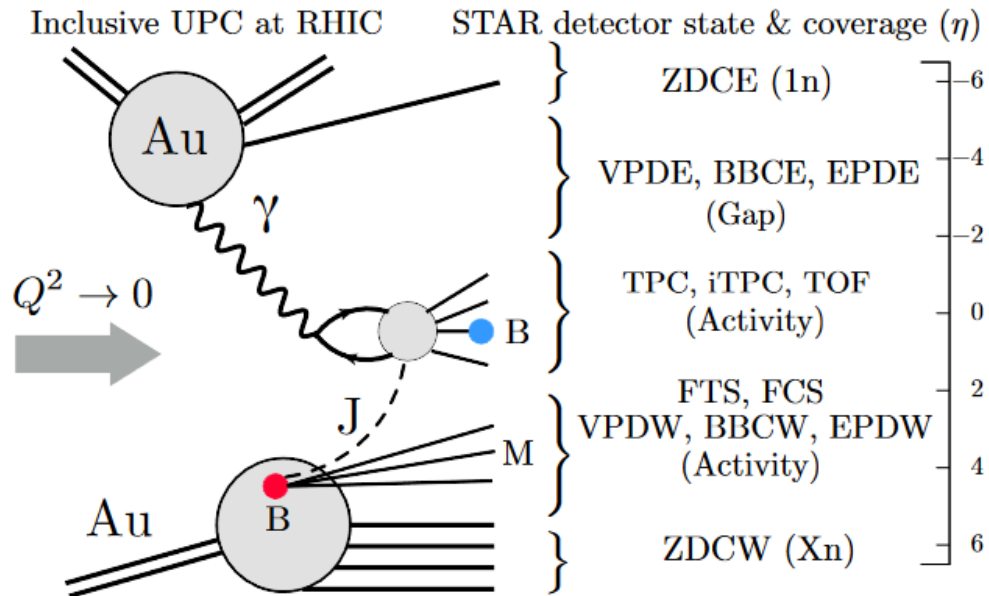

J. D. Brandenburg, N. Lewis,
P. Tribedy, Z. Xu, arXiv:2205.05685
(2022)

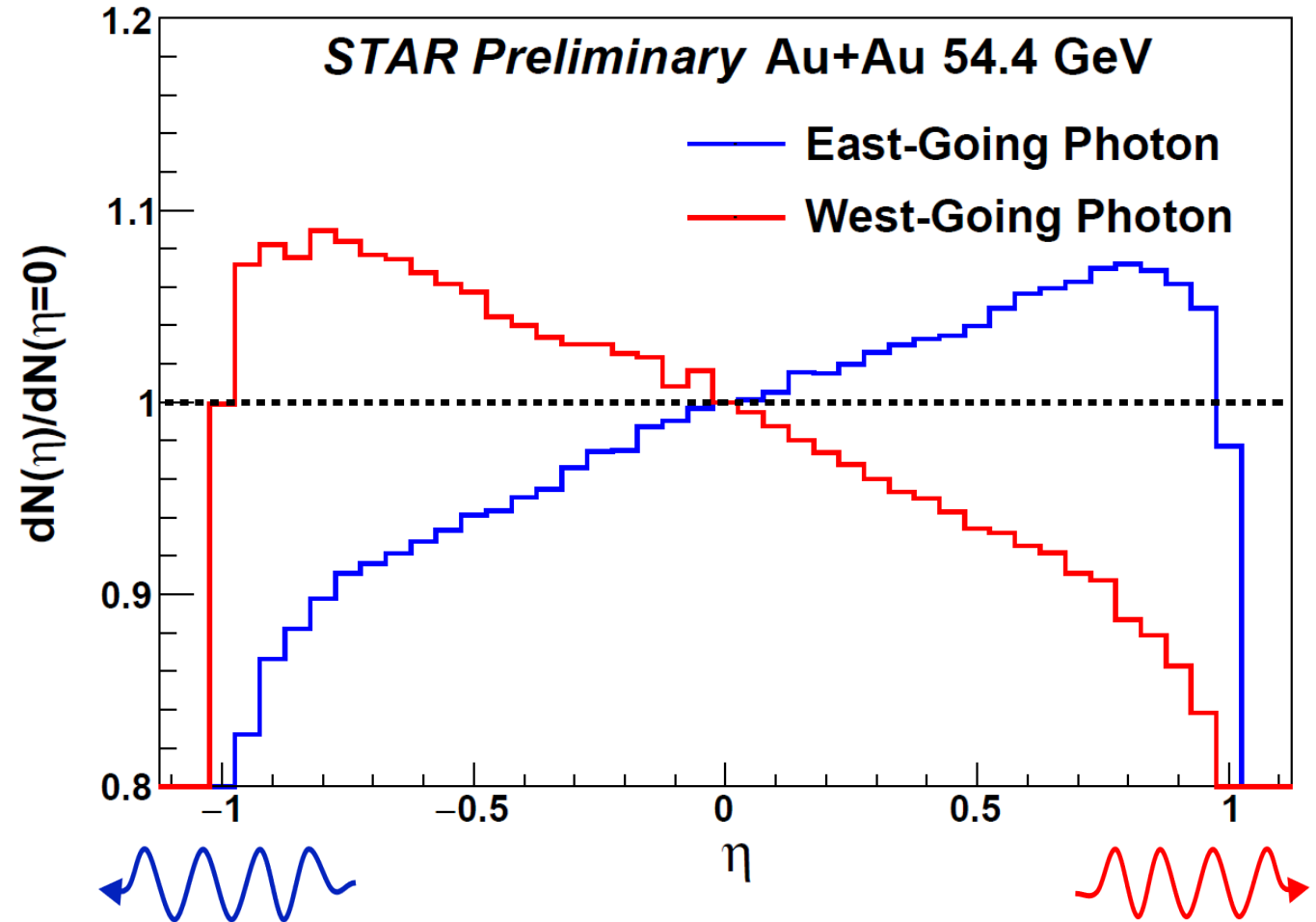

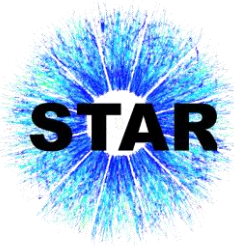

Defining γA and AA event classes

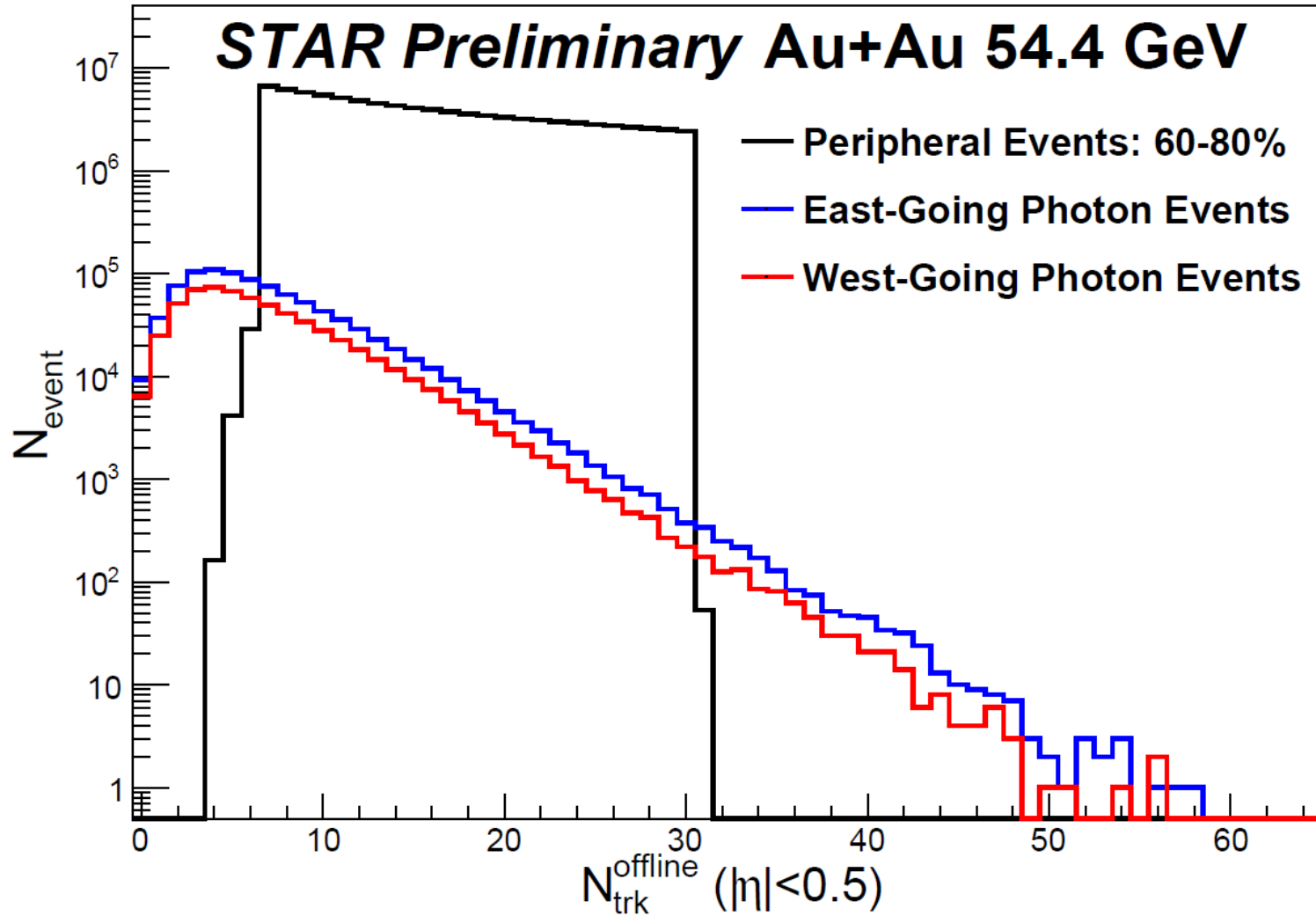

Most photonuclear events have low multiplicity, consistent with very peripheral Au + Au collisions

Using 60 – 80% peripheral collisions as a baseline and to estimate behavior of peripheral background

Y-Shaped baryon flux-tube in lattice QCD

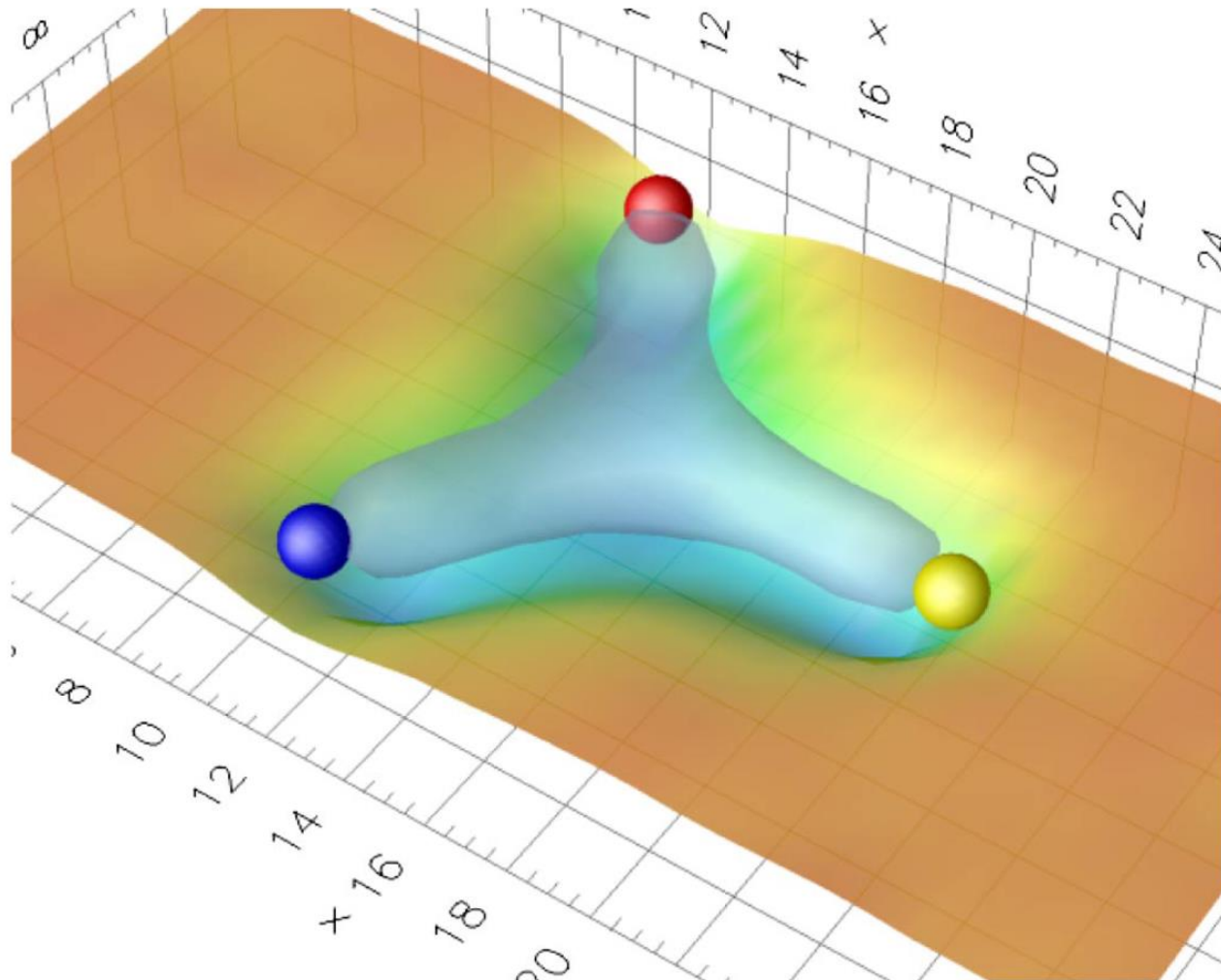

- **Some lattice calculations have suggested the formation of a Y-shaped color flux tube among the three quarks at long distances**

T. T. Takahashi, *et al* Phys. Rev. Lett. **86**, 18 (2001)

T. Takahashi, *et al*, Phys. Rev. D **65**, 114509 (2002)

- **Still under investigation**

F. Bissey, *et al* Phys. Rev. D **76**, 114512 (2007)



String junction model

- **3D hybrid model:**
GLAUBER + MUSIC + URQMD
Model
 - **String junction where the baryon charge of the string can fluctuate towards the center of the string with tuning parameter λ_B**
 - $\lambda_B = 0.2$ reproduces the dN/dy of net-protons at STAR
- C. Shen and B. Schenke, PRC **105**, 064905 (2022)

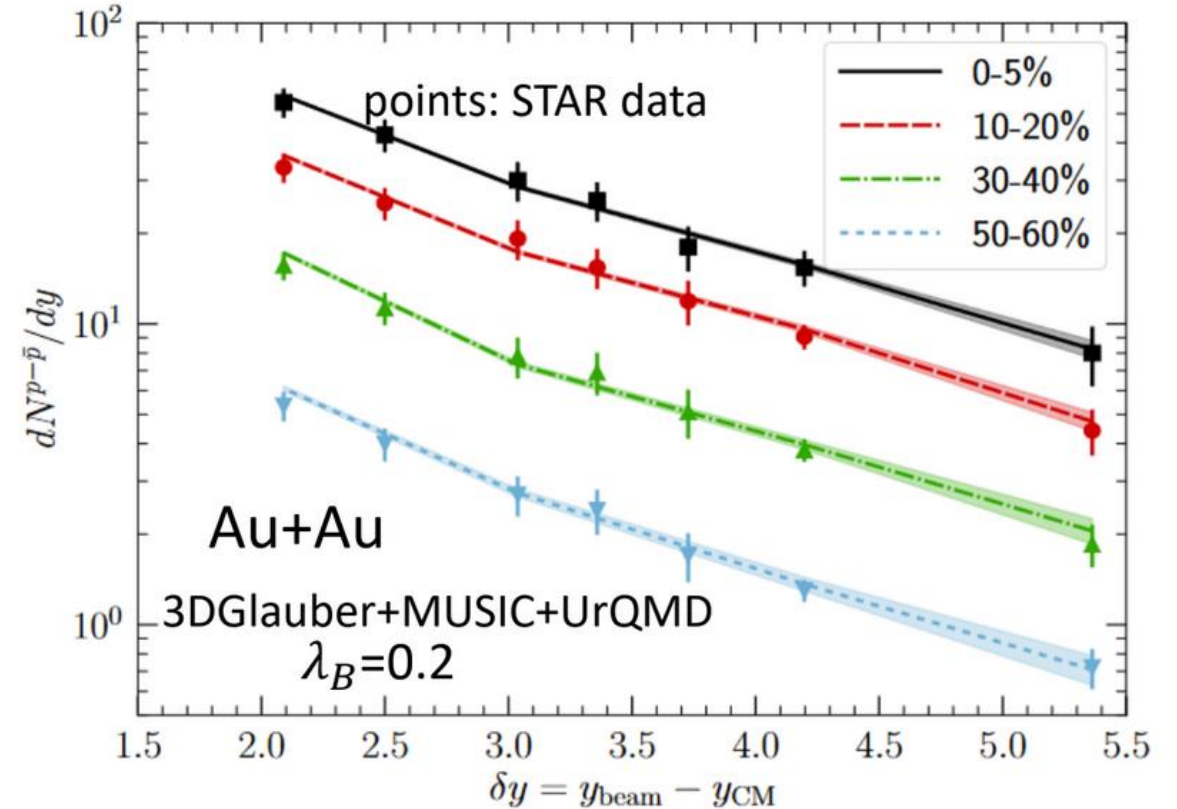

Plot from Wenbin Zhao, BES-Tea Seminar 2022

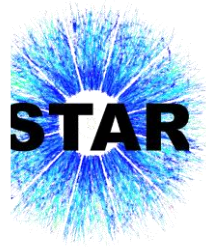

Net-Charge and Net-Baryon at $|y| < 1.0$, Predicted by UrQMD

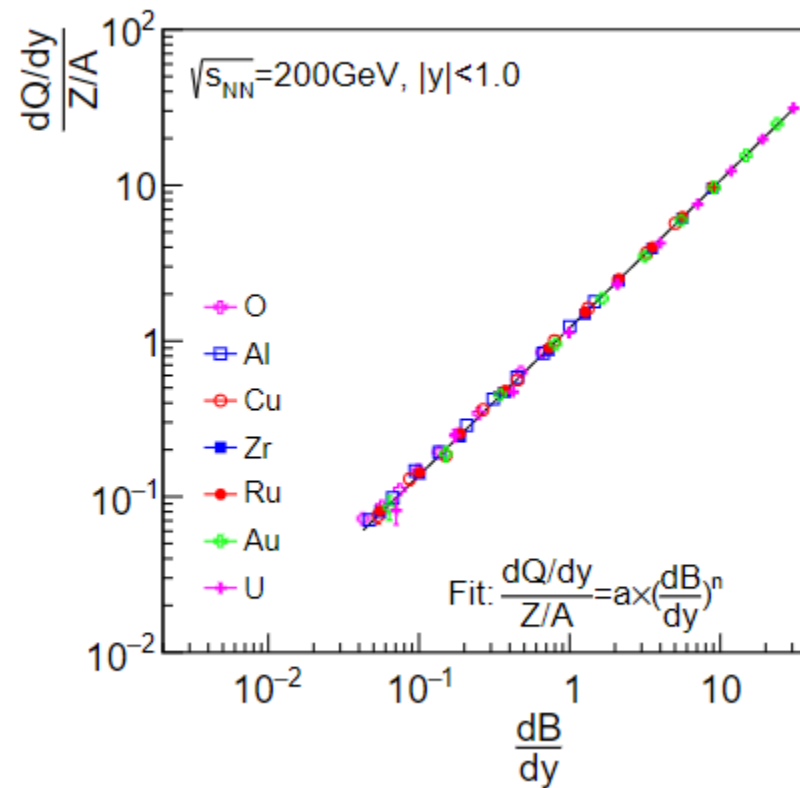

Courtesy: Z. Tang



Virtuality of ultra-peripheral Au + Au

$\sqrt{s_{NN}} = 54$ and 200 GeV. In UPCs the gold ions are the source of quasi-real photons. The size ($R_A \sim 1.2 A^{1/3}$) and charge ($Z = 79$) of gold ions (mass number $A = 197$) and the Lorentz boost $\gamma_L = 27 - 100$ at RHIC determines the energy of the quasi-real photons $E_\gamma = \gamma_L(\hbar c/R_A) = 0.8 - 2.8$ GeV. The virtuality and transverse momentum are $Q^2 \lesssim (E_\gamma/\gamma_L)^2 \simeq (\hbar c/R_A)^2 = 0.0008$ GeV². The typical range of the center of mass energy of the photon-nucleon system is $W_{\gamma N} = \sqrt{4E_\gamma E_A} \approx 9 - 34$ GeV for $\sqrt{s_{NN}} = 2 E_A = 54 - 200$ GeV. These numbers are close to what are quoted in Ref [36]. However, it is

Screenshot of J. D. Brandenburg, N. Lewis, P. Tribedy, Z. Xu, arXiv:2205.05685 (2022)

Gamma+Au and Au+Au on the same plot

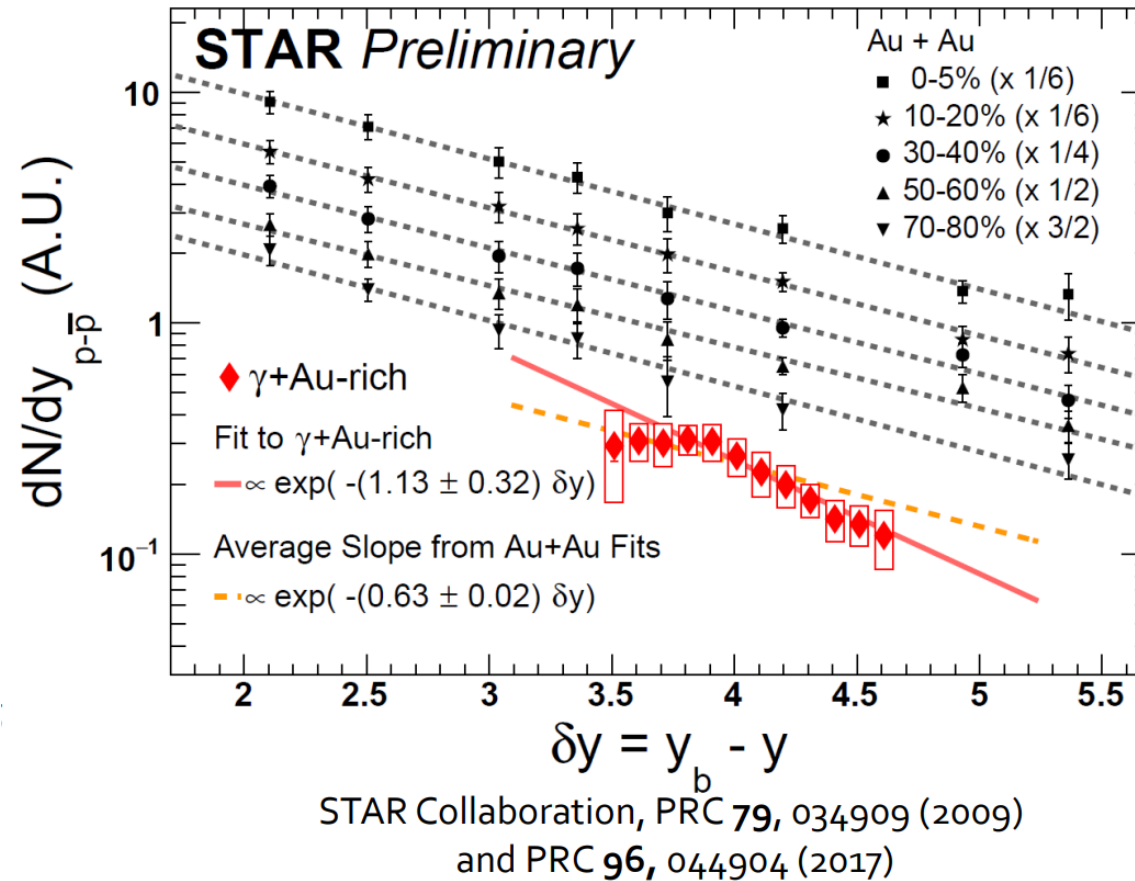



Fitting to PYTHIA data

- γ + Au-rich points acceptance:
 $-4.6 \lesssim y - Y_{\text{beam}} \lesssim -3.4$
- Central value fit range:
 $-4.0 < y - Y_{\text{beam}} < -0.81$
- Estimate Uncertainty by adjusting fit range:
 $-4.0 < y - Y_{\text{beam}} < -0.61$
 $-4.0 < y - Y_{\text{beam}} < -1.01$
- Slope: 2.43 ± 0.30
- Going to run more events in PYTHIA to have better coverage over our data acceptance

$$\text{Exponential Slope: } f(y - Y_{\text{beam}}) = A \exp(b \times (y - Y_{\text{beam}}))$$

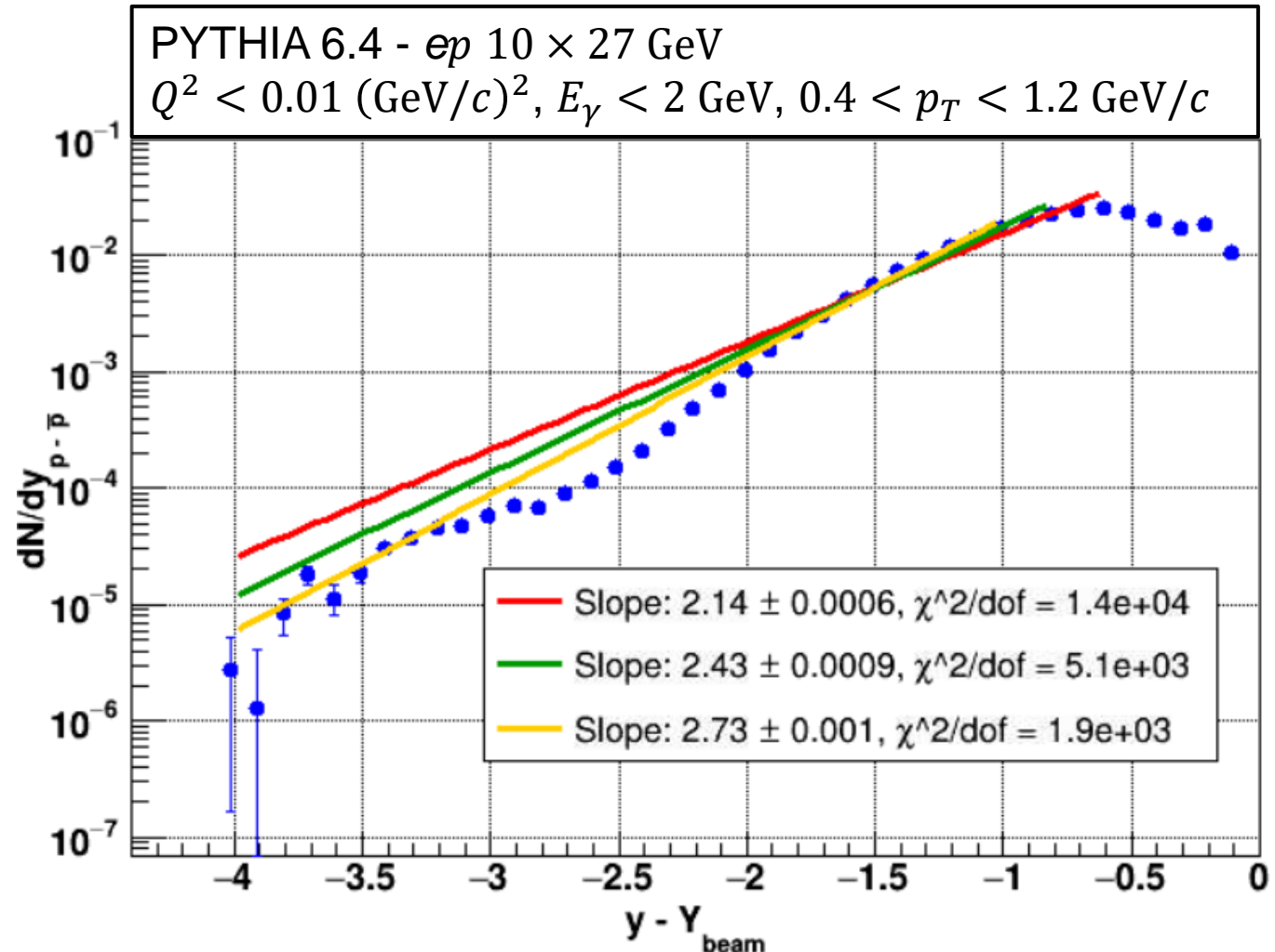

Thank you