

The Aachen Gas Database

RD51 Collaboration Meeting

Nick Thamm, RWTH Aachen University

CERN - 07.12.2023

The Aachen gaseous-detector group

- TPC R&D and operation
 - Participation in the T2K experiment (near detector gaseous TPC)
 - Involved in the ongoing upgrade
 - Calibration of TPC data for optimum track reconstruction
- Construction of monitor chambers (Mini-TPCs)
 - Continuous measurement of gas quality for best tracker performance
 - Rolling calibration of TPC
 - Detector safety
- Mini-TPCs:
 - Measurements of electron drift parameters
 - Wide range of operating pressures and drift fields
 - Various types of anode topologies
 - Mixing of gases with sub-percent accuracy

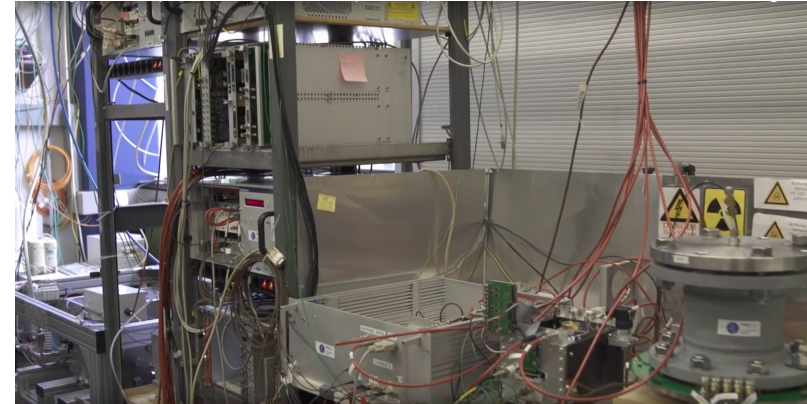

Measurement quantities

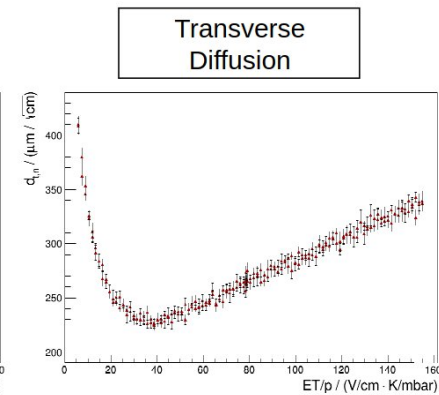
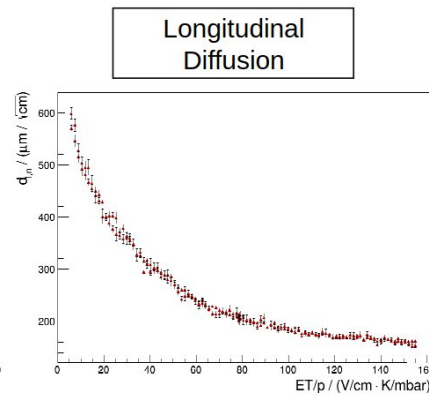
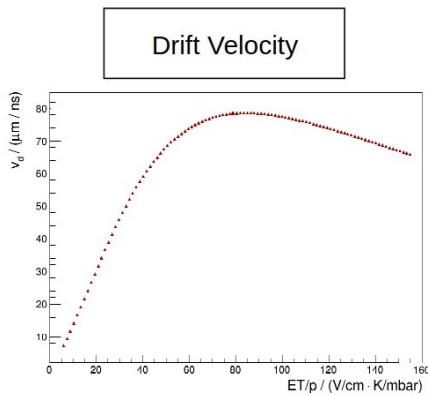
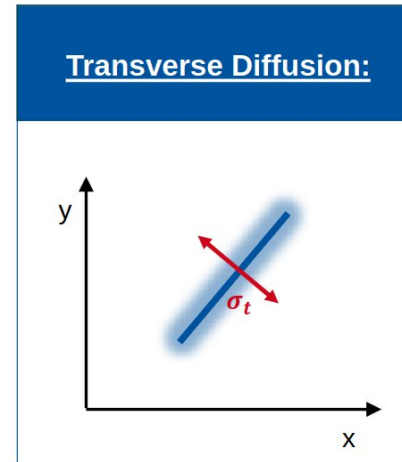
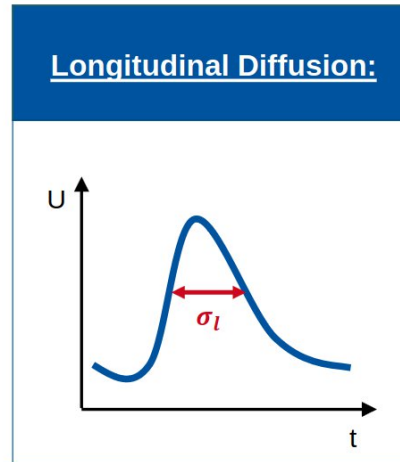
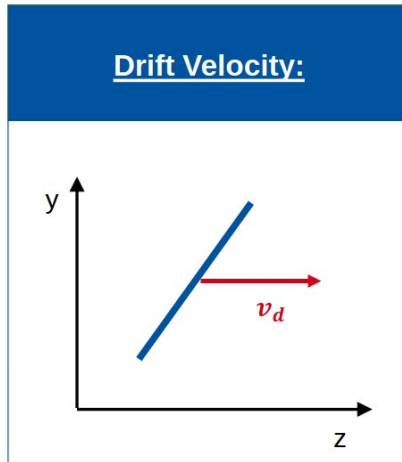

Gas Monitoring System @ ND280 / RWTH

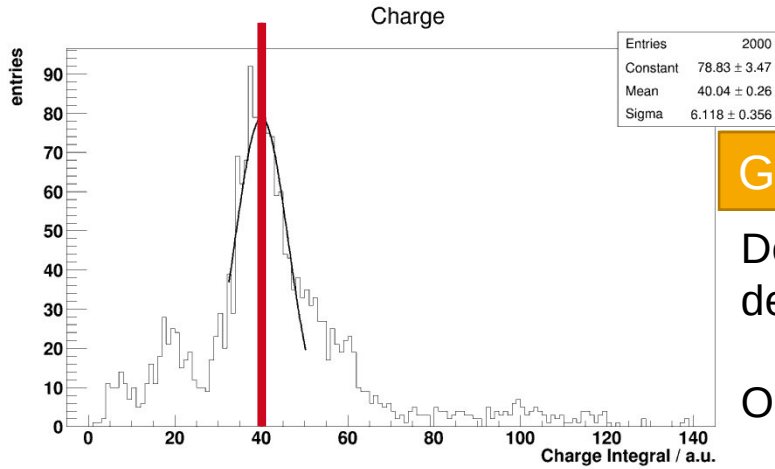

Gain Measurement

Detected charge from defined deposition

Only relative changes

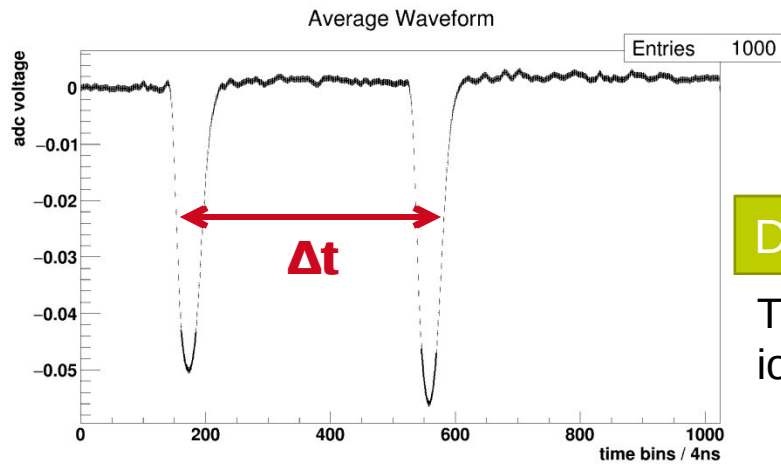
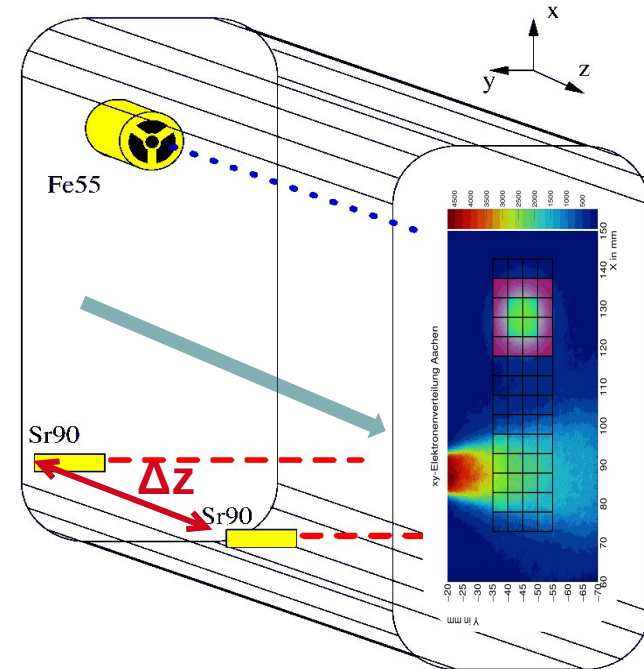

Drift Velocity

Time difference between ionization tracks of defined distance

Gas monitor chambers (GMC)

- Field-cage:

- Semi-flex PCB
- FR4 less hygroscopic
- Halogen-free
- Easier gluing
- New strip geometries

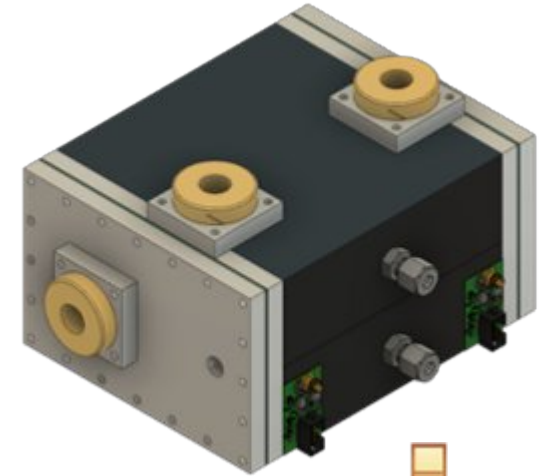
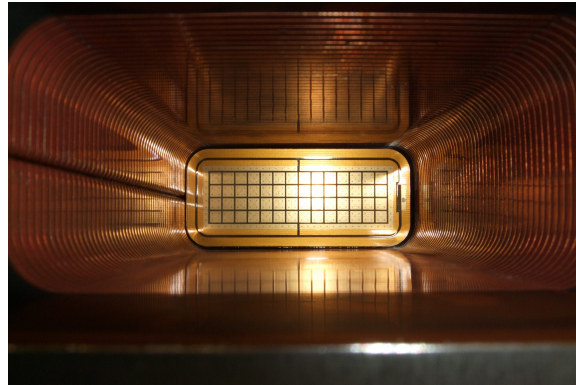

- Amplifier:

- Commercial solution
- Cremat charge sensitive amplifier and shaper

- Materials:

- Radiation-hard (PEEK / POM)
- Low outgassing

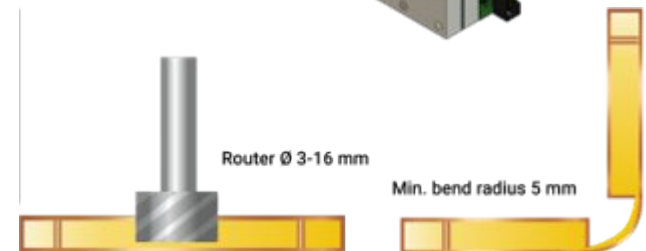

- Auxiliary sensors

- Temperature
- Pressure
- Humidity
- Oxygen

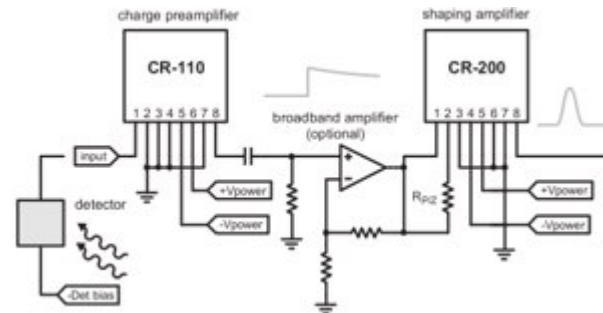

High/Low Pressure GMC

- Existing GMC setup for high pressures up to 10bar (HPGMC)
- Easily adaptable for low pressure measurements
 - External vacuum pump
 - Vacuum regulator integrated into system

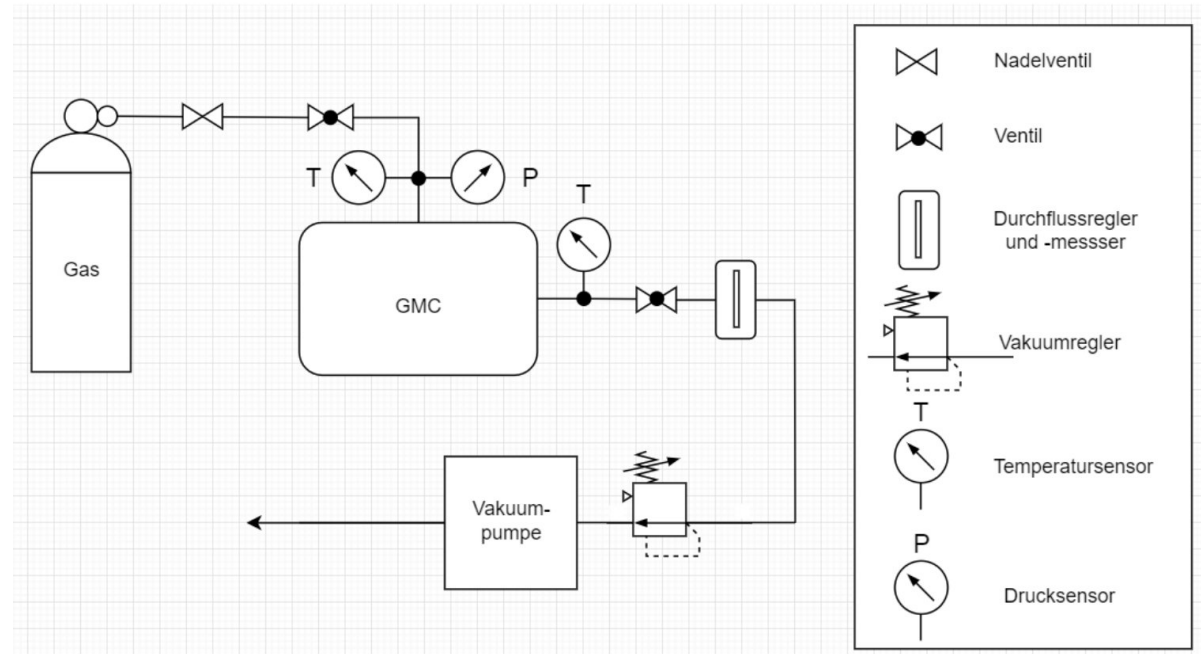
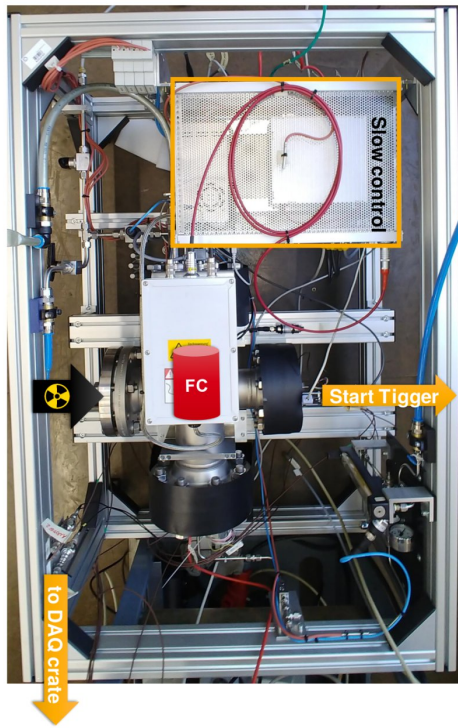

Results on high/low pressure

- Electron drift parameters scale with temperature and pressure
- Various measurement-techniques
 - Time-over-threshold
 - Waveform-fitting
- Results show good agreement with simulation

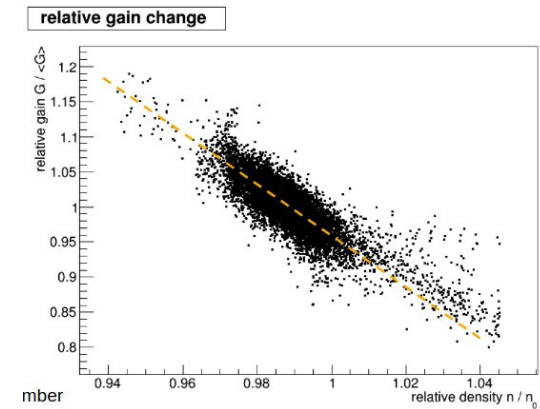
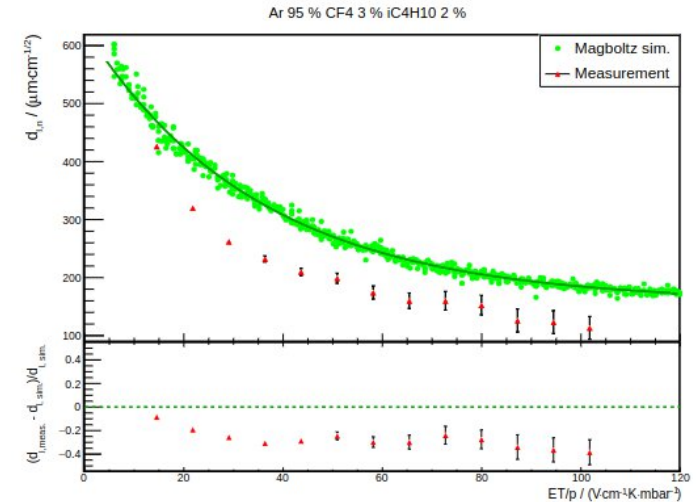
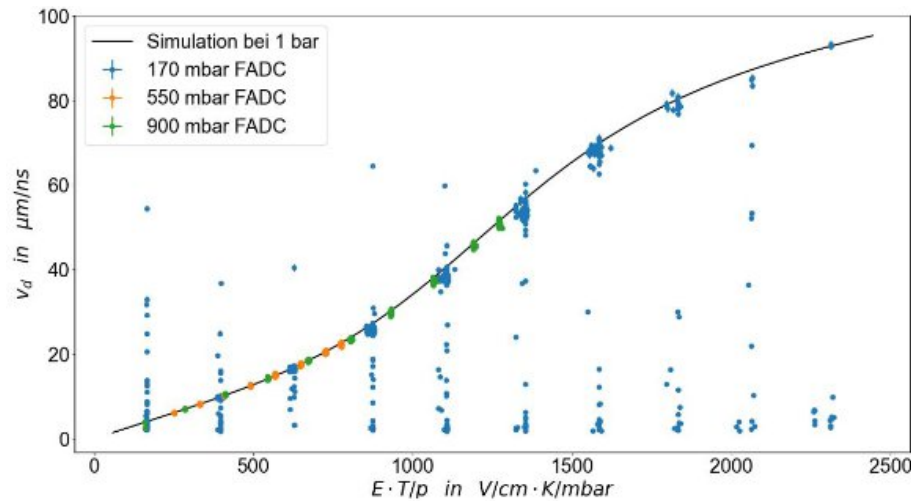

Measurement of first Townsend coefficient

- Measure current through drift-tube
- Scan voltage from 0V to 0(kV) to vary drift-field
- Induce current by photoeffect with UV-LED
 - Toggle LED to compensate for leakage currents
- Calculate from current to gas gain amplification
- Match gas gain to first Townsend coefficient
- Compare to simulation

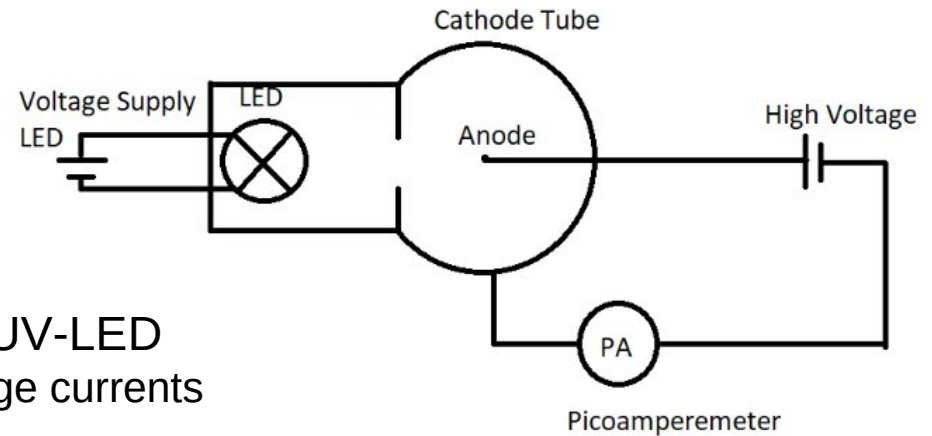

Simulation

- Magboltz / Pyboltz
 - Programs to simulate electron transport in gas mixtures
 - Drift velocity
 - Diffusion (longitudinal / transverse)
 - Gas gain (Townsend-coefficient / attachment)
 - <https://magboltz.web.cern.ch/magboltz/>
 - Actively maintained
 - Included into Garfield++
 - <https://github.com/UTA-REST/PyBoltz>
 - Not actively maintained?
- Custom scripts to run simulations in batch-mode on RWTH computer cluster

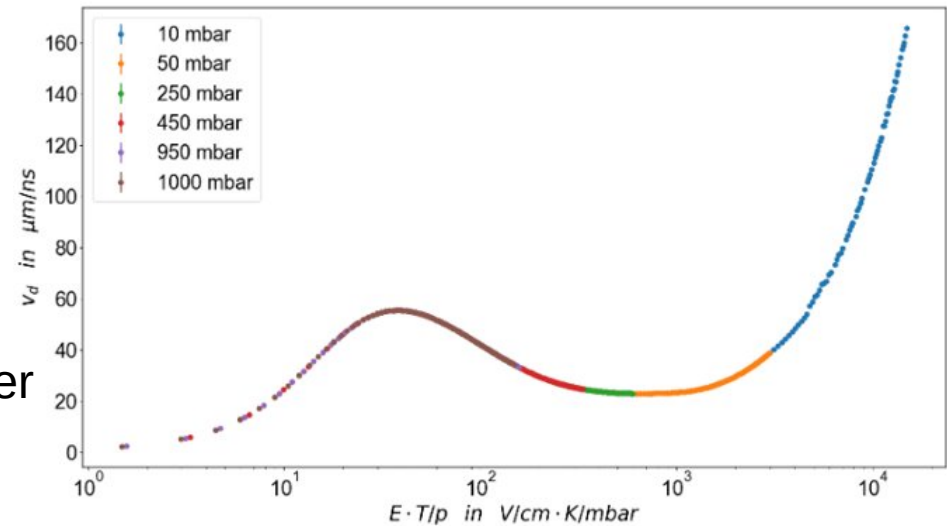

<https://www.rwth-aachen.de/gasdb>

Aachen GasDB Home About Citations Imprint Privacy Contact Us

0 ≤ E [V/cm] ≤ 1000000
 0 ≤ p [mbar] ≤ 11000
 0 ≤ B [T] ≤ 10

1. Select gases
 Argon (Ar) Methane (CH4)
 Strict

2. Select a gas mixture

3. Select a run

Ar_95.00_CF4_3.00_iC4H10_2.00 (T2K-gas); [magboltz 11.7] T2Kgas-H2O
 Ar_95.00_CF4_3.00_iC4H10_2.00 (T2K-gas); [vd_MM2013.5_PP] Ar_95_CF4_3_iC4H10_2 measurement, Chamber B, B = 0T, H2O < 5 ppm, O2 < 1 ppm
 Ar_95.00_CF4_3.00_iC4H10_2.00 (T2K-gas); [vd_MM2013.1] T2K-gas measurement, H2O < 10 ppm, O2 < 1 ppm, Ch. B
 Ar_90.00_CH4_10.00 (P10); [magboltz 11.9] Ar-CH4-HPGMC
 Ar_95.00_CH4_5.00 (P5); [magboltz 11.7] Ar-CH4-P5

Download a Python template for importing and working with the data

Plot Style: Scatter
 Marker Size: 6

x-axis Variable: E-T/p [V/cm-K/mbar]
 x-axis Type: Linear
 y-axis Variable: v_z [µm/ns]
 y-axis Type: Linear

- Ar_95.00_CF4_3.00_iC4H10_2.00 (T2K-gas); [magboltz 11.7] T2Kgas-H2O
- Ar_95.00_CF4_3.00_iC4H10_2.00 (T2K-gas); [vd_MM2013.5_PP] Ar_95_CF4_3_iC4H10_2 measurement, Chamber B, B = 0T, H2O < 5 ppm, O2 < 1 ppm
- Ar_95.00_CF4_3.00_iC4H10_2.00 (T2K-gas); [vd_MM2013.1] T2K-gas measurement, H2O < 10 ppm, O2 < 1 ppm, Ch. B
- Ar_90.00_CH4_10.00 (P10); [magboltz 11.9] Ar-CH4-HPGMC
- Ar_95.00_CH4_5.00 (P5); [magboltz 11.7] Ar-CH4-P5

gasDB - features

Aachen GasDB

Imprint

Publisher
Published on behalf of the Rector of RWTH Aachen University.

RWTH Aachen University
Templergraben 55
52062 Aachen (street address)

52056 Aachen (mailing address) Phone: +49 241 80 1
Fax: +49 241 80 92312
Email: impressum@rwth-aachen.de

RWTH Aachen University is a public institution represented by the Rector, Univ.-Prof. Dr. rer. nat. Dr. h.c. mult. Ulrich Rüdiger.

Regulatory Authority
The Ministry of Culture and Science of the Federal State of North Rhine-Westphalia, Völklinger Straße 49, 40221 Düsseldorf.

Sales Tax Identification Number
In accordance with § 27 Sales Tax Law: DE 121689807

Content Liability
Department Spokesperson:
Prof. Dr. Stefan Roth
Phone: +49 241 80 23688
Email: roth@physik.rwth-aachen.de

Aachen GasDB

Overview

This database is filled with both simulations and measurements. At the moment, only simulation runs performed with [MagBoltz](#), configured and run through [Garfield++](#) on our local computing cluster, are available. The corresponding [MagBoltz](#) versions are given within the run names of the simulations. Measurements are done in-house with various detectors of the Gas Monitoring Chamber type (T2K-style [GMC](#) and [HPGMC](#)). Some data was imported from publications, see the run names for the original sources.

Usage

The workflow is from left to right:

1. Select the desired gases one by one from the dropdown list, then click the "Submit Gases" button.
 - Uncheck "Strict" if additional gases are allowed in the mixture, as available.
2. Select a specific mixture from the dropdown list, then click the "Submit Mixture" button.
 - You can type in the field to filter the mixtures and only display those which match your input.
3. Select a run from the dropdown list, then click the "Add Run to List" button to add it to your plotting and download list.

By default, no range restrictions are applied to E , p , or B . If desired, these have to be set before submitting the gas mixture.

Runs on the runs list can be downloaded. Error bars displayed in the plots correspond to the total errors, but exported data distinguishes between statistical and systematic errors. The exported data is in human readable format and can be read into Python with our example project [example.py](#).

For online plotting, a number of options are available, most of which are self-explanatory. Density scaling corrections for comparing electron swarm parameters at different pressures or temperatures are a useful preselection possibility, since simulation runs can contain scans in the gas density. More details on density corrections can be found under [Density Scaling](#).

Density Scaling

For a given gas mixture, all swarm parameters depend in one way or another on the gas density. Given sufficient distance from phase boundaries of the mixture components, the ideal gas law can be used to factor in the change in gas density:

$$pV = nRT$$

gasDB - features

- Web-Interface
 - For quick comparisons
- .csv data-download
 - Including python-parsing example script
- Introductory information on gas-parameters / simulation
 - What exactly is provided and how does T/p-scaling work
- Citation information
 - Bibtex format
- Imprint
 - For legal reasons. Adjusted RWTH-version
- Contact information
 - For questions or requests for additional datasets

<https://publications.rwth-aachen.de/record/837464>

The screenshot shows the RWTH Publications record for 'The Aachen gas-database'. The record is highlighted with a red border. The main content area is divided into sections: Information, References (0), Discussion (0), and Files. The title is 'The Aachen gas-database'. The authors listed are Hamacher-Baumann, Philip; Roth, Stefan; Perot, Cameron Joseph; Radermacher, Thomas; Thamm, Nick; Koch, Lukas Uwe Gerhard. The year is 2021. The description is 'Charge transport and multiplication in gas (frei); Detector modelling and simulations (charge transport and multiplication) (frei); Gaseous detectors (frei)'. The abstract states that the Institute of Experimental Physics III B at RWTH Aachen University operates the Aachen Gas Database, which consists of a large quantity of simulations and measurements of electron transport parameters in gas mixtures. As of December 2021, the project is not yet finished. It is planned to add more records to the database. You can find an overview of the available versions below. The record type is 'Dataset', the origin is 'Public Reference', and the language is 'English'. The internal identifiers are 'RWTH-2021-06228' and 'Datensatz-ID: 821391'. Below the main record, there are three related datasets: 'The Aachen gas-database v2021.1', 'The Aachen gas-database v2021.2', and 'Corrigendum to "The Aachen gas-database v2021.2"'. Each related dataset has its own set of authors, a unique identifier, and options to view files or fulltext. At the bottom, there is a QR code and a list of collections where the record appears: Public Reference, 021000_20140620, 133510, and 021000. The record was created on 2021-06-29 and last modified on 2022-06-29.

- Official, DOI traceable record of gas-database via RWTH library
- Associated datasets with multiple releases (appended data)

gasDB - data release

ub RWTH AACHEN UNIVERSITY RWTH Publications English Deutsch guest login

Search Submit Personalize Help

Information References (0) Discussion (0) Files

The Aachen gas-database v2021.1

Hamacher-Baumann, Philip ; Roth, Stefan ; Perot, Cameron Joseph ; Radermacher, Thomas ; Thamm, Nick ; Koch, Lukas Uwe Gerhard

2021

Online
DOI: 10.18154/RWTH-2021-05537
URL: https://publications.rwth-aachen.de/record/820318/files/Aachen_gas-database_v2021.1.sql
URL: https://publications.rwth-aachen.de/record/820318/files/gasdb_manual.pdf
URL: <https://wiki-3ab.physik.rwth-aachen.de/gasdb/>

Einrichtungen

1. Lehrstuhl für Experimentalphysik III B (133510)

Inhaltliche Beschreibung (Schlagwörter)
Charge transport and multiplication in gas (frei) ; Gaseous detectors (frei) ; Detector modelling and simulations (charge transport and multiplication) (frei)

Kurzfassung
The Institute of Experimental Physics III B at RWTH Aachen University operates the Aachen Gas Database. It consists of a large quantity of simulations and measurements of electron transport parameters in gas mixtures. In-house measurements were done with various detectors of the Gas Monitoring Chamber type (TZK-style Gas Monitoring Chambers and a High Pressure Gas Monitoring Chamber). To date, the simulation data runs were performed with MagBoltz, configured and run through Garfield++ on our local computing cluster. Some data was imported from publications, see the run names for the original sources. Currently, the data can be used in two different ways:
The Chair of Experimental Physics III B provides a web frontend, available at the link above. Alternatively, the complete database can be downloaded from this page and used locally. Instructions can be found in the accompanying pdf. This version v2021.1 was published in June 2021 and includes the runs up to 25,956. The project is still ongoing.

Related:

Dataset
Hamacher-Baumann, P.* ; Roth, S.* ; Perot, C. J.* ; Radermacher, T.* ; Thamm, N.* ; Koch, L. U. G.*

The Aachen gas-database

BibTeX | Endnote XML | RIS

The record appears in these collections:
Faculty of Mathematics, Computer Science and Natural Sciences (Fac.1) > Department of Physics
Document types > Other document types
Research data > Datasets
Publication server / Open Access
Public records
Publications database
133510

Record created 2021-06-09, last modified 2021-07-03

OpenAccess:
Aachen_gas-database_v2021.1 - SQL
gasdb_manual.pdf (additional files)
External link:
Fulltext

Rate this document:
(Not yet reviewed)

⇒ Add to personal basket
⇒ Export as Author List with Ids BibTeX (UTF-8), EndNote XML, EndNote Text, RIS, MARC, Print MARC, MARC XML, DC
⇒ Request correction
⇒ Submit fulltext

- Database release accessible via individual DOI
 - Provides dataset, "manual" for dataset and citation information

Why this talk?

- Discussion about database in WG3 for the DRD1 proposal
- Common objective D3.1.1 of WG3
- Proposal to discuss a future common database at this RD51 CM

Scientific Proposal & Research Framework

v1.3

Reference	Description	Common Objective
D3.1.1	Gas properties: drift velocity, diffusion for e- and ions, gain measurements, light emission, attachment, etc.	Common gas properties database

Options

- Use database as is
 - Add external measurements and simulations on specific request (with limited service)
- Host and maintain database in a common effort
 - within WG3 "Gas and Material Studies" of DRD1
- Take the database as "inspiration" for a future tool with extended capabilities
 - There are many old gas databases, which could be imported
 - CERN tool Zenodo could be used to provide datasets

In case of interest, please contact us!

roth@physik.rwth-aachen.de

Thank you!

Backup

Conclusion

- Aachen gas database is a useful tool for developing and operating gaseous detectors
- Results are traceable and publicly available
- Database is easily extendable and published results could be imported
- Ongoing work on adding more results and new measurement techniques

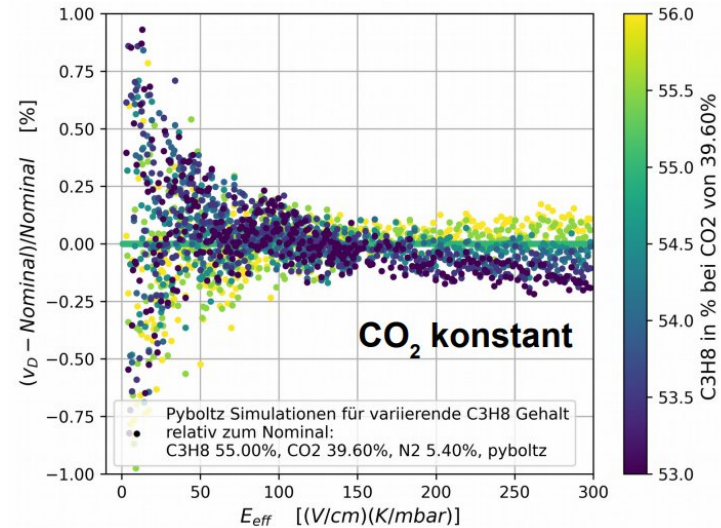
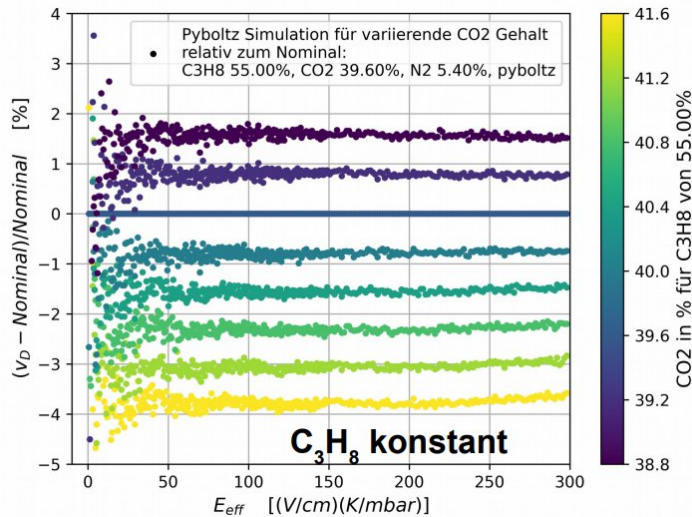

- Reconstructing impurities via simulation
- VD mostly sensitive to percentage of alkanes
- No exact match between measurement/simulation:
--> Probably detector effect

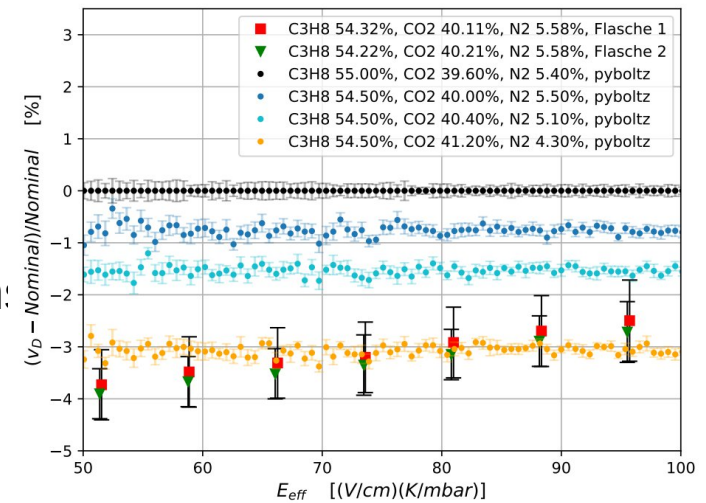

Gas Monitoring System - Limitations

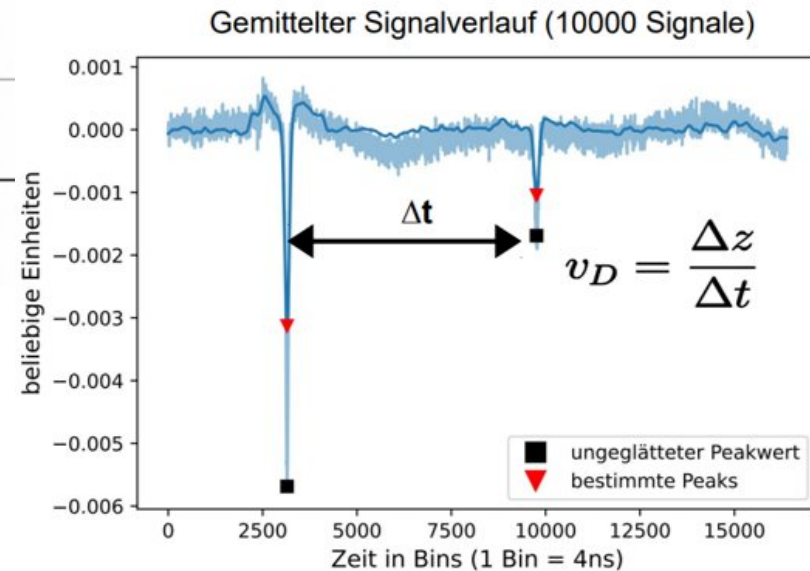
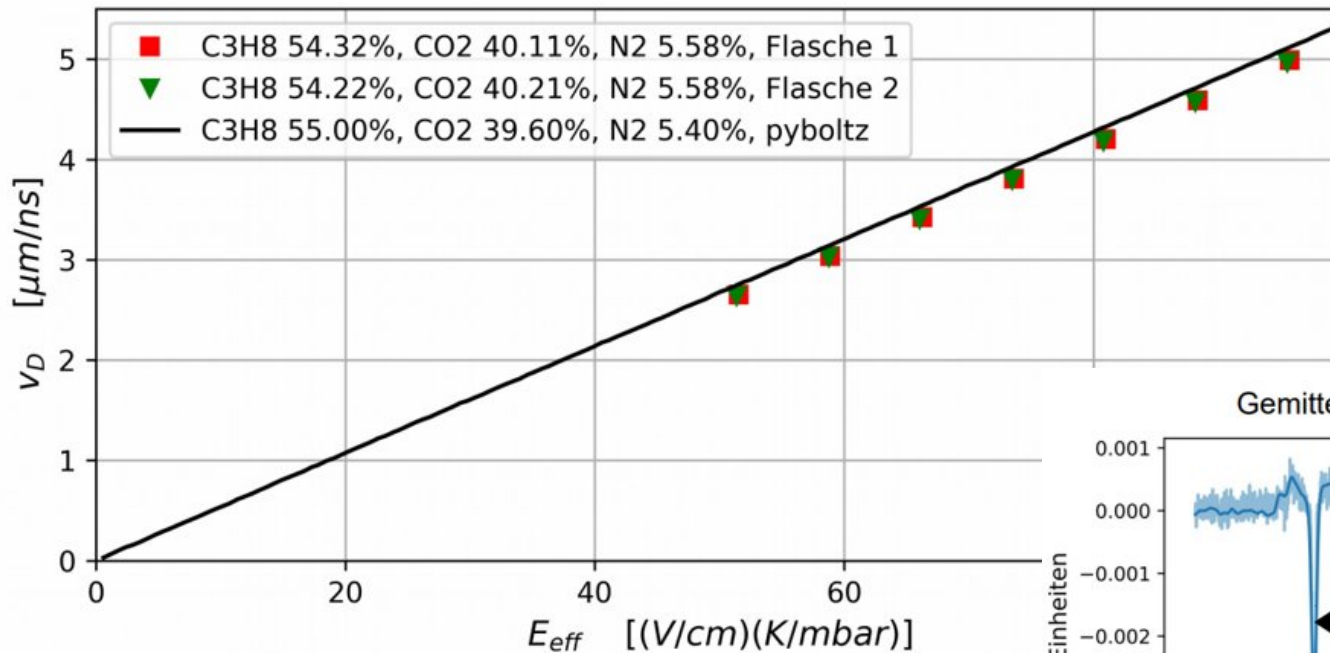

- Not limited to specific gas-mixture
 - Equipped for drift gases with electronic readout
- Not suitable to reconstruct gas-mixture after measurement

Technical aspects

- Data sources
 - Measurements, papers, simulations
- Very lightweight load from outside interactions
 - No powerful server needed
 - Refurbished lab-PC as server
- Interface self-hosted on dedicated lab-server
 - Podman / docker container with Flask / jQuery / Plotly / Bootstrap
- Database hosted on cluster infrastructure
 - Central mysql installation
 - Read-only user for data-access
 - Read/Write user to add data
- Domain hosted by RWTH and forwarded to lab-server
 - RWTH points to Physik-3B-Apache installation (webserver)
 - Webserver reverse proxies to lab server (apache)
 - Managed by physics IT-department

Database structure

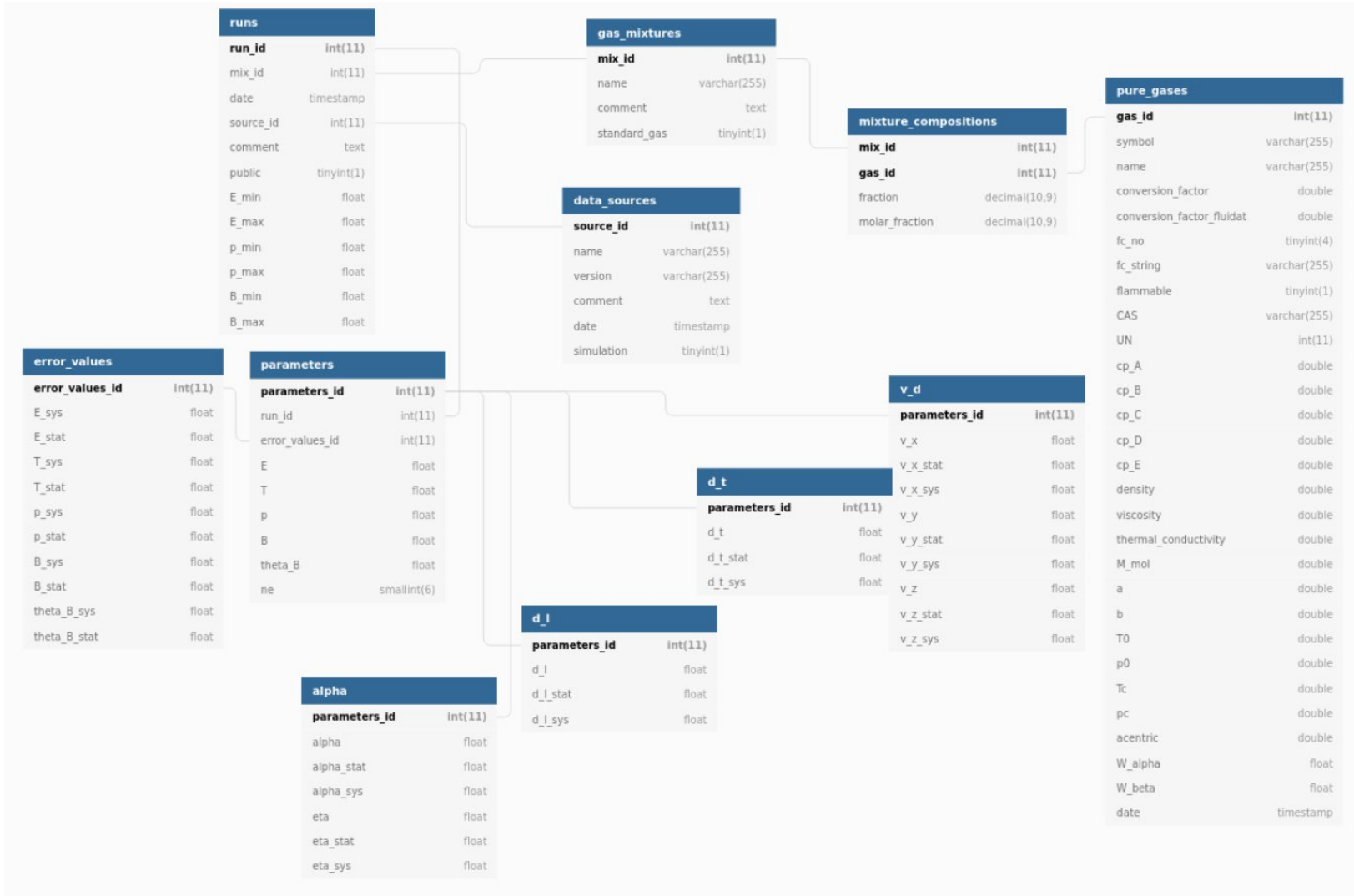

Gain Calibration

- **Correction depends on amplification technology (E-field shape)**
 - Pixel / pad detectors use homogenous amplification field (1st order)

$$\frac{\Delta G}{G_{STP}} = m \frac{\Delta \frac{p}{T}}{\frac{p_0}{T_0}}$$

$$G_{STP} = G(T_0, p_0)$$

- typical values for $m \approx -3$
- Application in TPC calibration
- Calculate current gain for single PAD

from calibration DB

$$G_{PAD} = G_{STP} \left(m \left(\frac{p/T}{p_0/T_0} - 1 \right) + 1 \right)$$

Measured by monitoring chamber

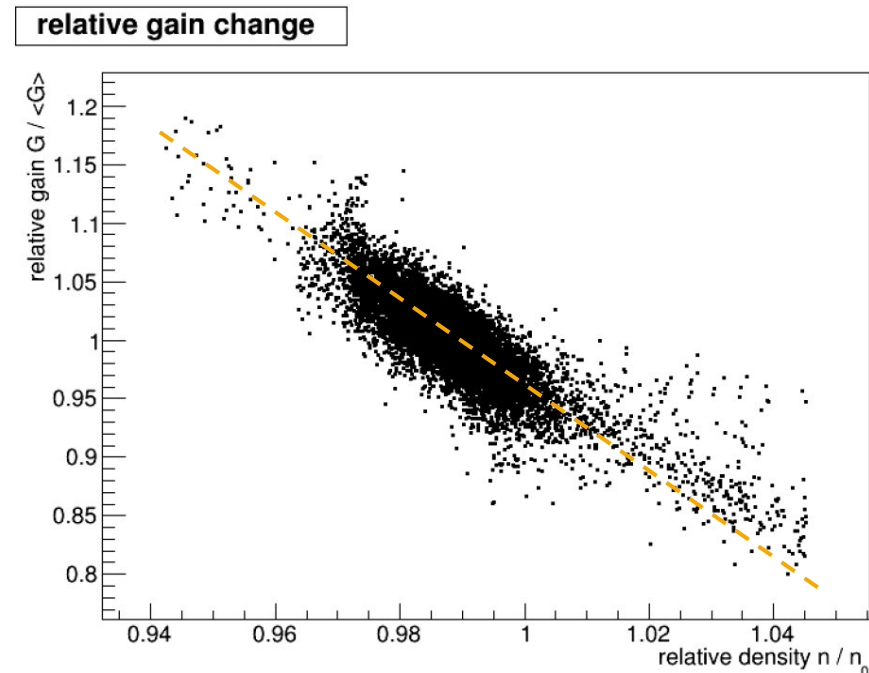

Gas Amplification

- **Density effects**

- Gas amplification changes a lot over the runtime of an experiment
- Caused by density fluctuations (i.e. weather)

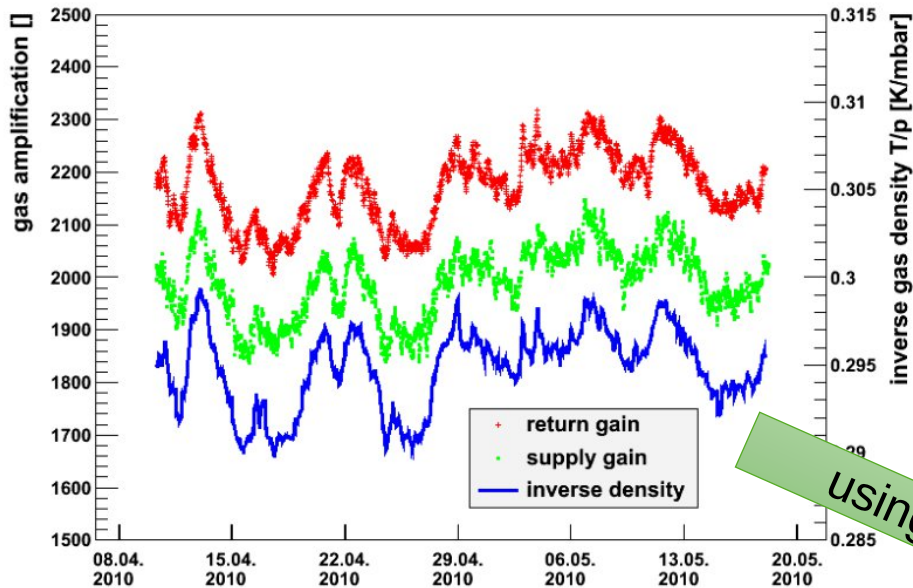

using m

Corrected vs. Uncorrected gain

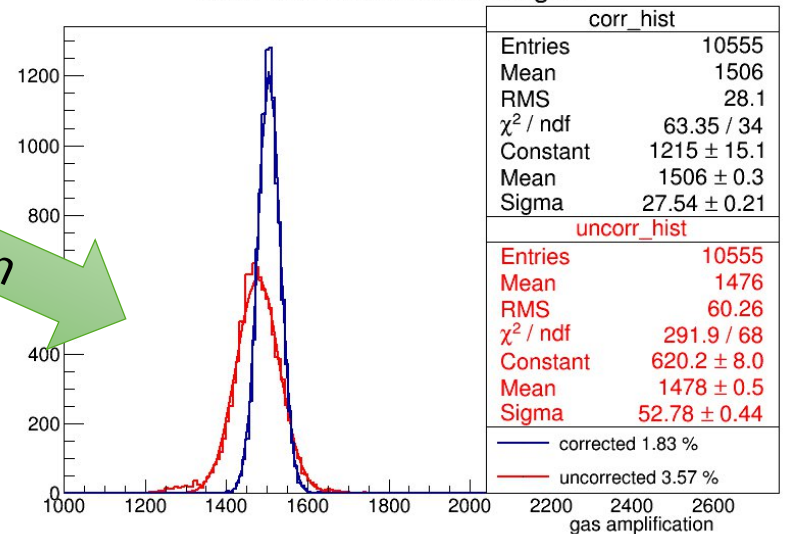

Slow-control

- GMC is technically a digital sensor
 - No external interactions required
 - Measurements are written onto self-contained DAQ-PC

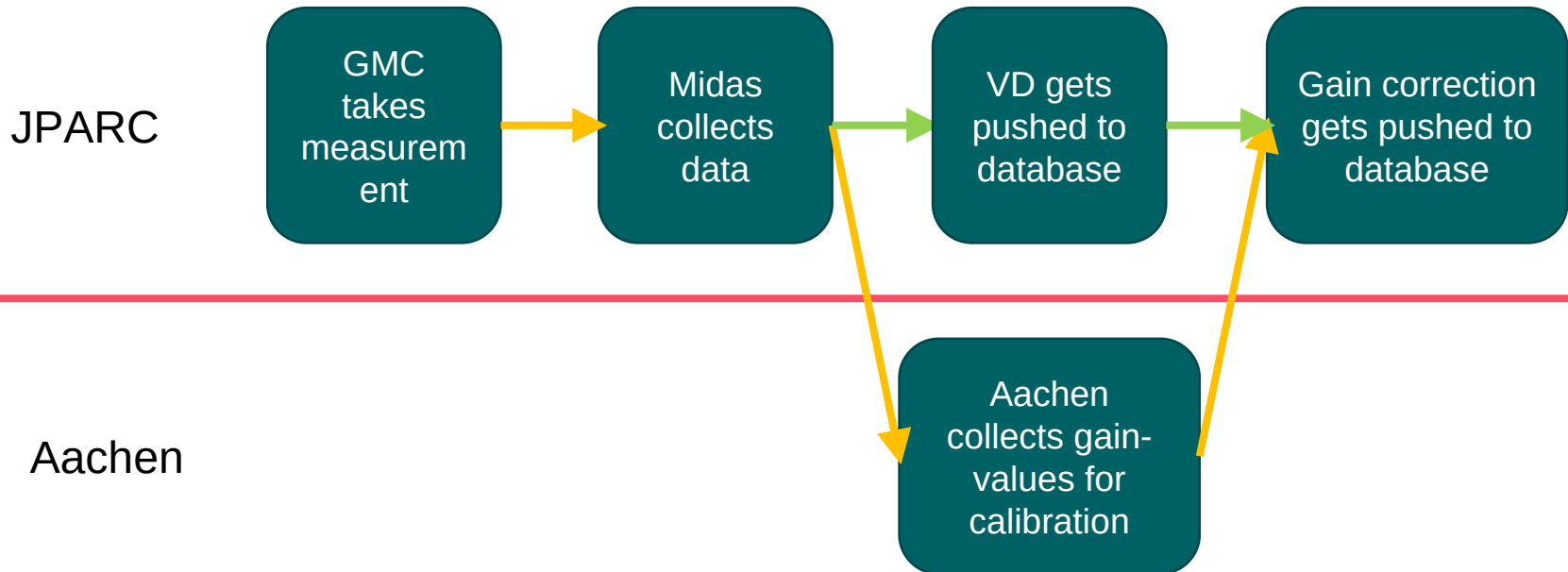

Configurations

- Pledged 4 GMCs
- Multiple anode-setups possible
 - ERAMs and Bulk-MMs
- Two suggestions:

Setup 1	Setup 2
Gas-supply (vTPC) – Bulk	Gas-supply (vTPC) – Bulk
Gas-exhaust (vTPC) – Bulk	Gas-exhaust (vTPC) – Bulk
Gas-supply (HAT) – ERAM	Gas-exhaust (HAT) – Bulk
Gas-exhaust (HAT) – ERAM	Gas-exhaust (HAT) – ERAM

Modular Deployment of GMCs

Only needs gas connection, power and ethernet link

Current setup with 2 crates

- 2 GMC crates
 - 2 Gas Monitoring Chambers
 - Pressure sensors
 - Temperature sensors
 - Preamps
- 2 (VME) DAQ and HV crates
 - FADC
 - Trigger Board
 - SiPM power supply
 - Anode & cathode power supply
 - § Security Loop
 - Storage slot
 - Computer



➤ Total of 4 crates ~20U in 19" rack space (2x 10U)

Gas System

Current situation



Gas system construction: modularity

- Gas systems are made of several modules (*building blocks*): mixer, pre-distribution, distribution, circulation pump, purifier, humidifier, membrane, liquefier, gas analysis, etc.
- Functional modules are equal between different gas systems, but they can be configured to satisfy the specific needs of all particle detector.
- Implementation: control rack and crates (flexible during installation phase and max modularity for large systems)

Control rack

Control crate (PLCs)

Modules crates
Profibus connection to control crate



16/04/2018

R. Guida CERN/EP-DT

7

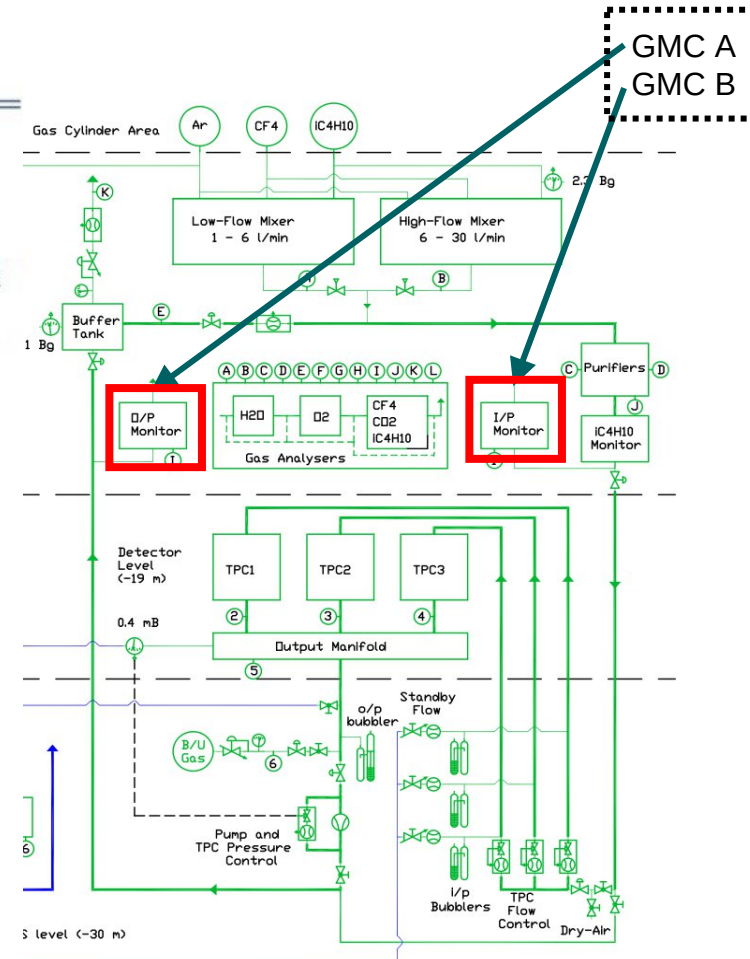

Gas-System / installation

- GMC should have security loop
 - Switch off, when no T2K-gas is present
 - Best: hardware, OK: software
- Ideally separate gas-stream for GMC
 - Currently 6 l/h
- GMC could profit from auxiliary measurements from gas-system
 - E.g.: Water, Oxygen
- For radioactive sources, GMC should be accessible from top
 - If rack-space is rare, GMC could be mounted on drawer rails
 - Flexible tube connection
 - Rack dimensions need to be known!
- GMC has over-pressure valves
 - Is there a need to connect them to gas-loop?

Questions?!

- Which GMC configuration is desired by the HAT-group?
- Where will the GMCs be installed?
 - Gas-shack or detector-level?
- Is there any public information available for the gas-system?
 - Sensors, connections, ...
- Will there be any interaction between gas-system and GMC?
- What is the best meeting, to ask GMC-integration related questions?
- Where should we provide any information on t2k.org?
 - Currently old information hidden in ~5 submenus
 - [nd280/tpc/operation/gas/GasMonChambers](#)

Amplifier

- New amplifier-modules testing going on with custom PCB
 - +/- 12V input (provided by VME backplane)
 - 3 channels (charge sensitive amplifier + gaussian shaper)
 - Test input for calibration and functionality-checks

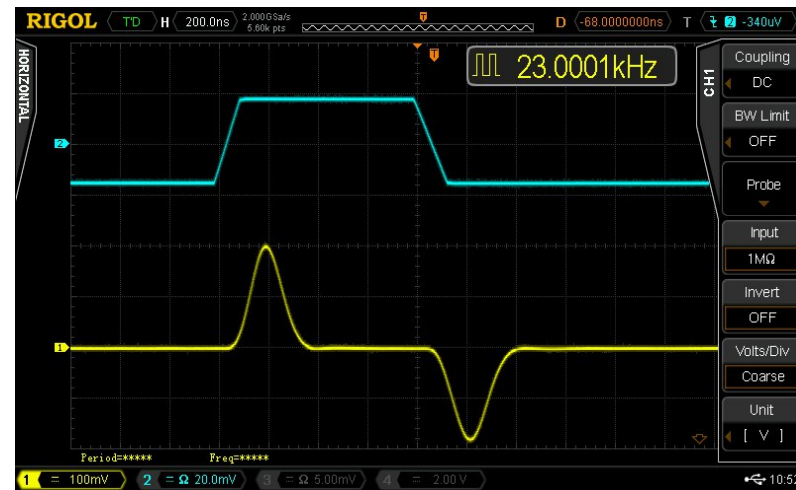
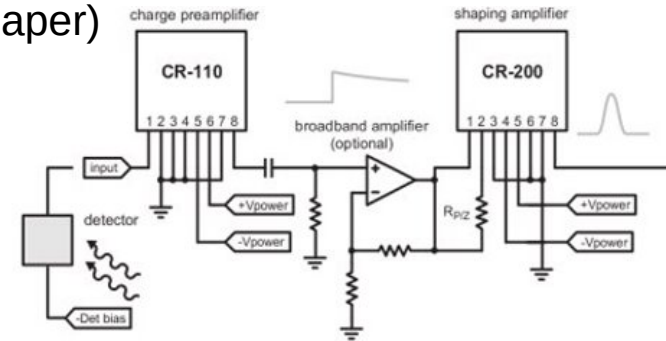
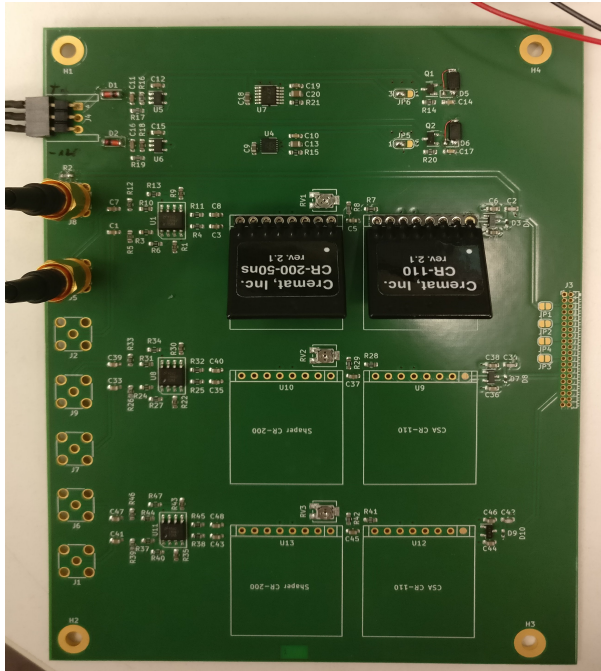

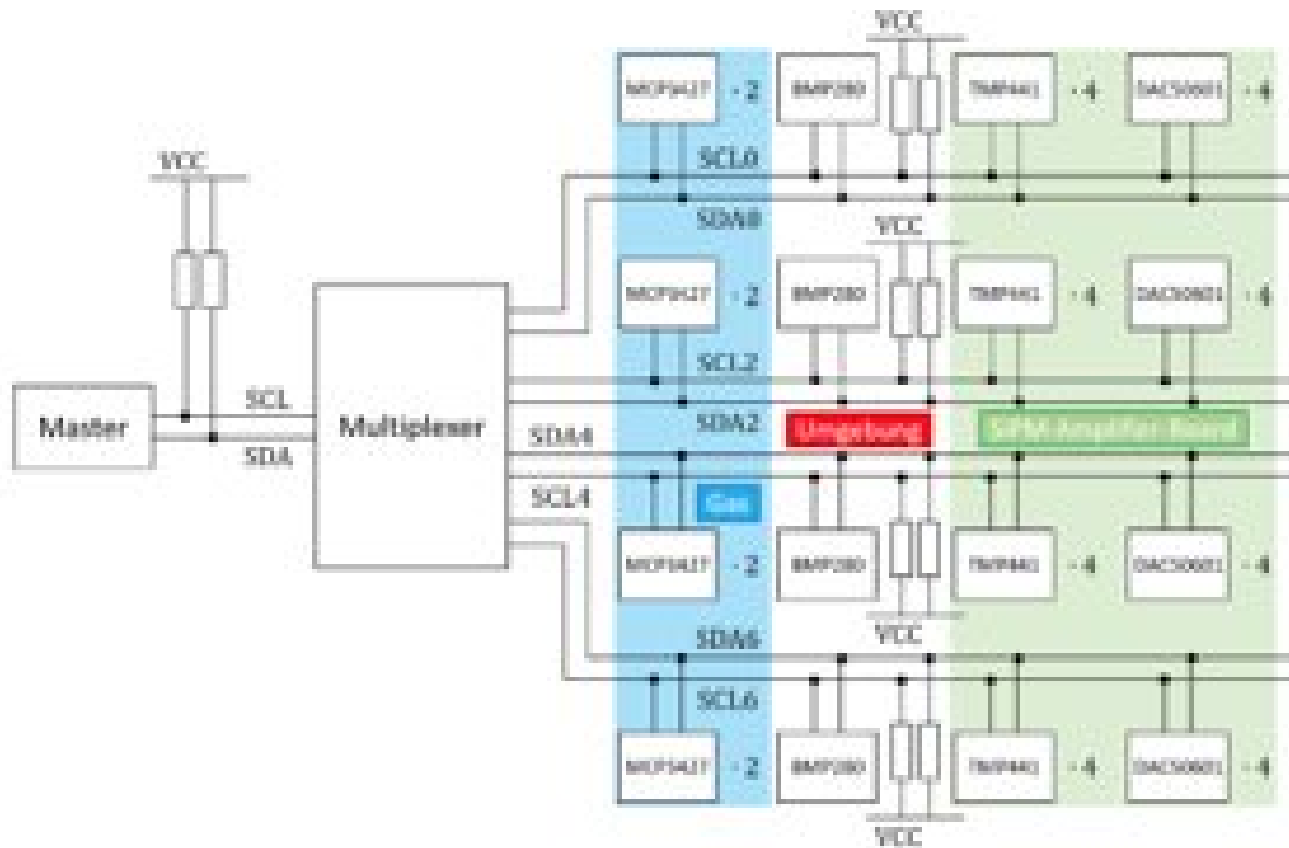

Micromegas Subdivision

- **MM pads are subdivided into groups**
 - Horizontal bars for drift measurement
 - Ring/Pad for gain-measurement
 - Ring -> Veto pad

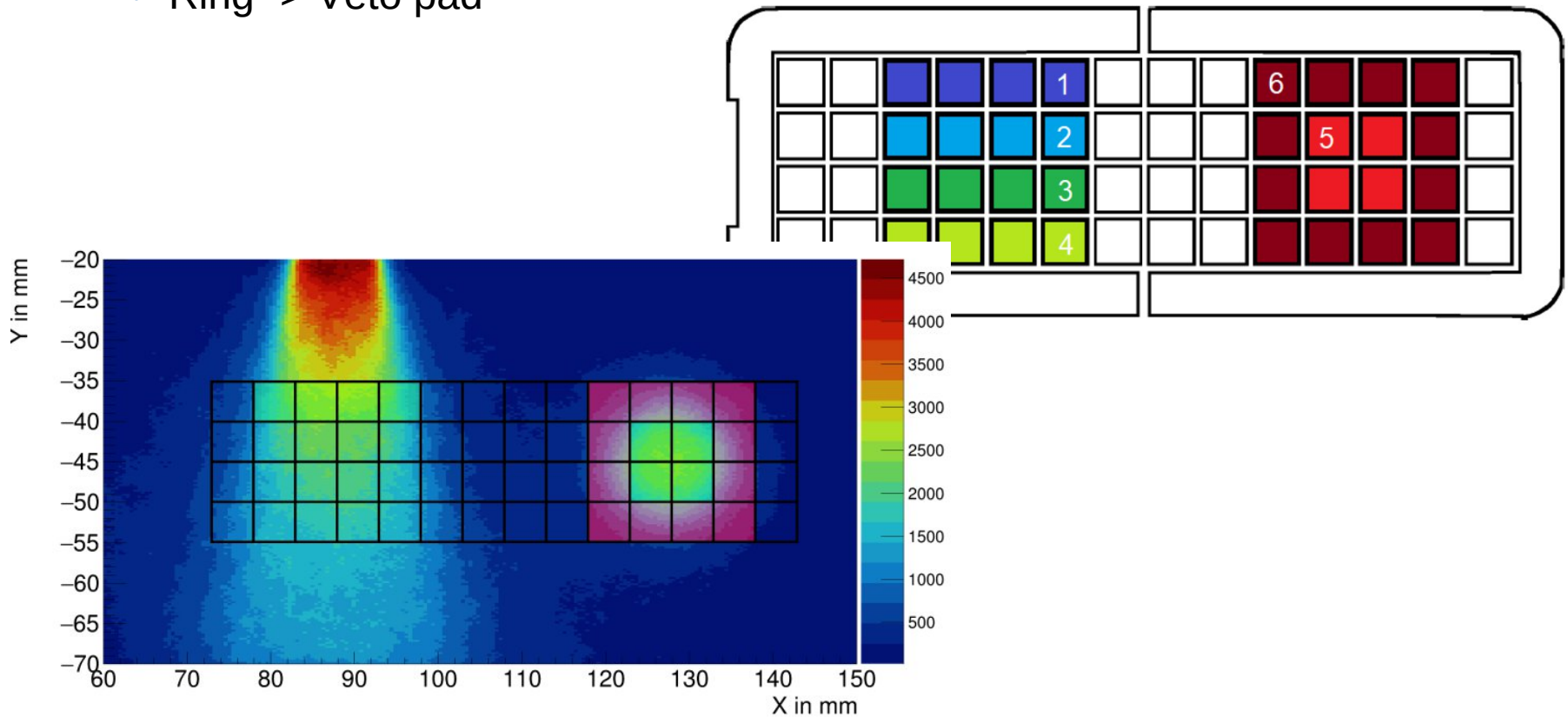

Amplifier / DAQ

- Combination of charge-sensitive-amplifier and shaper
 - Several combinations possible (various gain-options / shaping times)
- Waveforms are digitized with CAEN VX1720
 - 250MS/s, 12bit FADC

Specifications		Assume temp =20°C, $V_s = \pm 6.1V$, unloaded output	
	CR-110-R2		units
Preamplification channels	1		
Equivalent noise charge (ENC)*			
ENC RMS	200	electrons	
Equivalent noise in silicon	0.03	femtoCoul.	
Equivalent noise in CdZnTe	1.7	keV (FWHM)	
ENC slope	2.4	keV (FWHM)	
Gain	4	elect. RMS /pF	
Gain	1.4	volts / pC	
Rise time **	62	mV / MeV(Si)	
Decay time constant	7	ns	
Unsaturated output swing	140	μs	
Maximum charge detectable per event	-3 to +3	volts	
Power supply voltage (V_s)	1.3×10^7	electrons	
maximum	2.1	pC	
minimum	$V_s = \pm 13$	volts	
Power supply current (pos)	$V_s = \pm 6$	volts	
(neg)	7.5	mA	
Power dissipation	3.5	mA	
Operating temperature	70	mW	
Output offset	-40 to +85	°C	
Output impedance	+0.2 to -0.2	volts	
	50	ohms	

Specifications		Assume temp =20°C, $V_s = \pm 9V$, unloaded output	
	CR-200		units
amplification channels	1		
polarity	non-inverting		
operating temperature range	-40°C to 85°C		
input noise voltage			
CR-200-50ns	115	μV RMS	
CR-200-100ns	90	μV RMS	
CR-200-250ns	60	μV RMS	
CR-200-500ns	47	μV RMS	
CR-200-1 μs	36	μV RMS	
CR-200-2 μs	30	μV RMS	
CR-200-4 μs	24	μV RMS	
CR-200-8 μs	22	μV RMS	
output impedance	<5	Ω	
output offset	-40 to +40	mV	
output temperature coefficient	-60 to +60	$\mu V / ^\circ C$	
power supply voltage (V_s)			
absolute maximum	$V_s = \pm 13$	volts	
minimum	$V_s = \pm 5$	volts	
quiescent power supply current	7	mA	
maximum output current	20	mA	
maximum output swing*	$V_s - 0.5$	volts	

* for CR-200-50ns maximum output is +/-6V or $V_s - 0.5$, whichever is less.

High voltage

- ISEG VME modules (same as old GMCs)
 - ISEG VHS 4005p / 500V (ERAM)
 - ISEG VHS 4060n / –6kV (Drift)
- Ripple and noise
 - $f > 10\text{Hz}$: $< 10\text{mVpp}$
 - $f > 1\text{kHz}$: $< 2\text{-}3\text{mVpp}$
- By now, no filter on MM installed
 - DLC more susceptible to noise?
- Connection via round solder-point

SPECIFICATIONS	VHS Common-GND (CG)
Polarity	Factory fixed, positive or negative
Ripple and noise ($f > 10\text{ Hz}$)	$< 10\text{ mV}_{\text{pp}}$
Ripple and noise ($f > 1\text{ kHz}$)	$< 2\text{-}3\text{ mV}_{\text{pp}}$
Stability	
Stability – $[\Delta V_{\text{out}} \text{ vs. } \Delta V_{\text{in}}]$	$< 1 \cdot 10^{-4} \cdot V_{\text{nom}}$
Stability – $[\Delta V_{\text{out}} \text{ vs. } \Delta R_{\text{load}}]$	$< 5 \cdot 10^{-4} \cdot V_{\text{nom}}$
Temperature coefficient voltage measurement	$< 50\text{ ppm / K}$
Temperature coefficient current measurement	$< 50\text{ ppm / K}$
Resolution – The resolution of measurable values depends on the settings of the sampling rate and the digital filter!	
Resolution voltage setting	$< 2 \cdot 10^{-6} \cdot V_{\text{nom}}$
Resolution current setting (trip)	$< 2 \cdot 10^{-6} \cdot I_{\text{nom}}$
Resolution voltage measurement ¹⁾	$< 2 \cdot 10^{-6} \cdot V_{\text{nom}}$
Resolution current measurement [$I_{\text{out}} > 20\text{ }\mu\text{A}$] ¹⁾	$< 2 \cdot 10^{-6} \cdot I_{\text{nom}}$
Measurement Accuracy – The measurement accuracy is guaranteed in the range $1\% \cdot V_{\text{nom}} < V_{\text{out}} < V_{\text{nom}}$ and for 1 year	
Accuracy voltage measurement	$\pm (0.01\% \cdot V_{\text{out}} + 0.02\% \cdot V_{\text{nom}})$
Accuracy current measurement [$I_{\text{out}} > 20\text{ }\mu\text{A}$]	$\pm (0.02\% \cdot I_{\text{out}} + 0.02\% \cdot I_{\text{nom}})$
Sample rates ADC (SPS)	5, 10, 25, 50, 60, 100, 500 ²⁾
Digital filter averages	1, 16, 64 ²⁾ , 256, 512, 1024
Voltage ramp up / down	$1 \cdot 10^{-4} \cdot V_{\text{nom}} / \text{s}$ to $0.2 \cdot V_{\text{nom}} / \text{s}$
Hardware limits	Potentiometer per module [$V_{\text{max}} / I_{\text{max}}$]
Limit monitor volt	2.5 V
Digital interface	VMEbus
Protection	Safety loop, over load and short circuit protected (ATTENTION: there is only one short circuit or arc per second allowed!)
HV connector	Redel 51 pole SHV
System connector	96-pin connector according to DIN 41612 (MMS HV compatible)
Safety loop connector	Lemo 2pole
Limit monitor connector	Lemo 2pole
Case	6U VME cassette (single and double width)
Dimensions – L/W/H	164mm 4HP,(8HP) / 6U VME cassette,
Operating temperature	0 – 40 °C
Storage temperature	-20 – 60 °C
Humidity	20 – 80 %, not condensing
Notes: ¹⁾ The resolution of measurable values depends on the settings of the sampling rate and the digital filter! ²⁾ Standard factory settings	

Table 1: Technical data: Specifications

- Pad dimensions:
 - Pitch: 5mm
 - Distance between pads: 0.5mm
- Larger veto-pads around segmented plane
- HV-ring around all pads
- Corner radius: 10mm

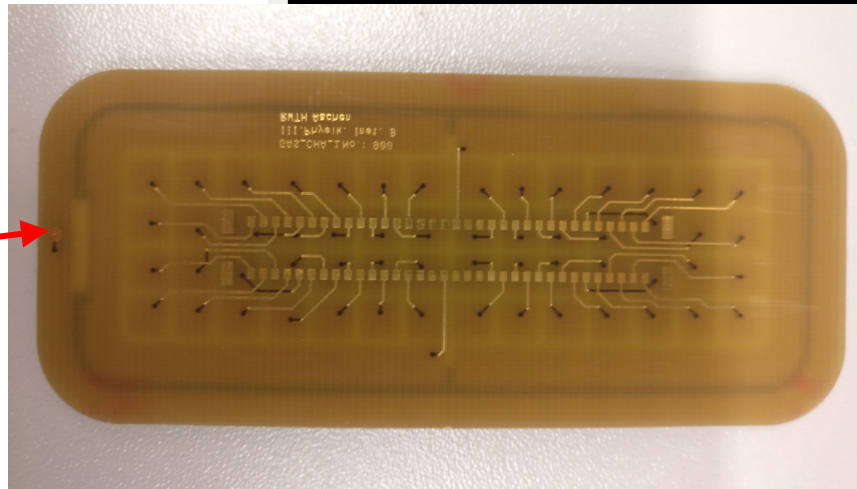
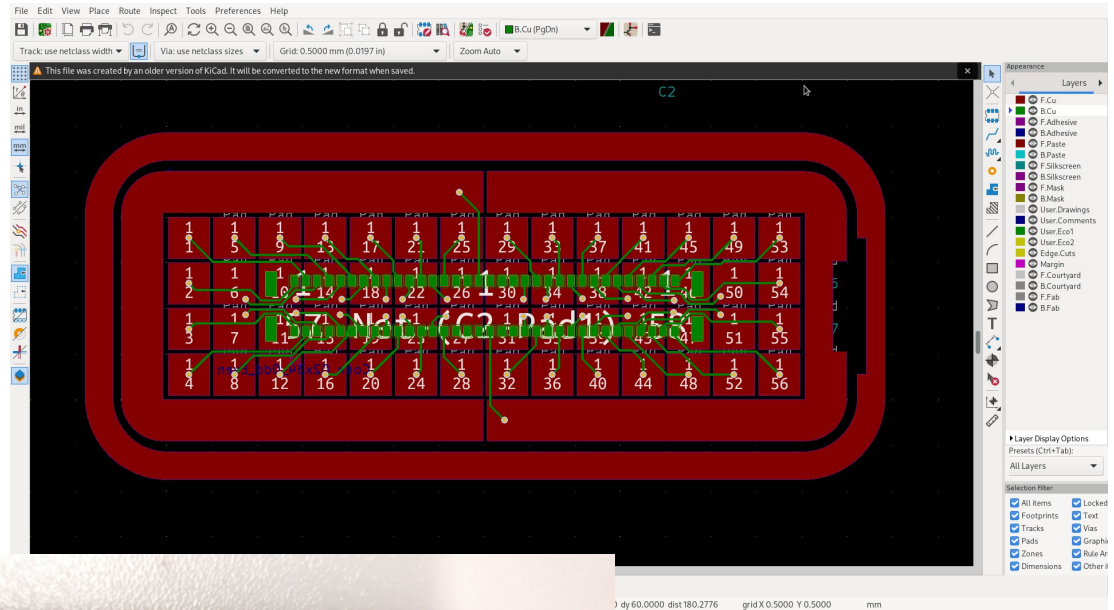

HV connection

Anode (Micromegas / ERAM)

- Large TPCs are changing technology
 - Bulk micromegas vs resistive micromegas (ERAM)
- Resistive layer introduces charge-spread
 - DLC foil acts as **intrinsic sparking protection**
 - **Charge-spread** reduces number of required pads
 - Mesh @ GND
 - **Equipotential plane** for whole detector.

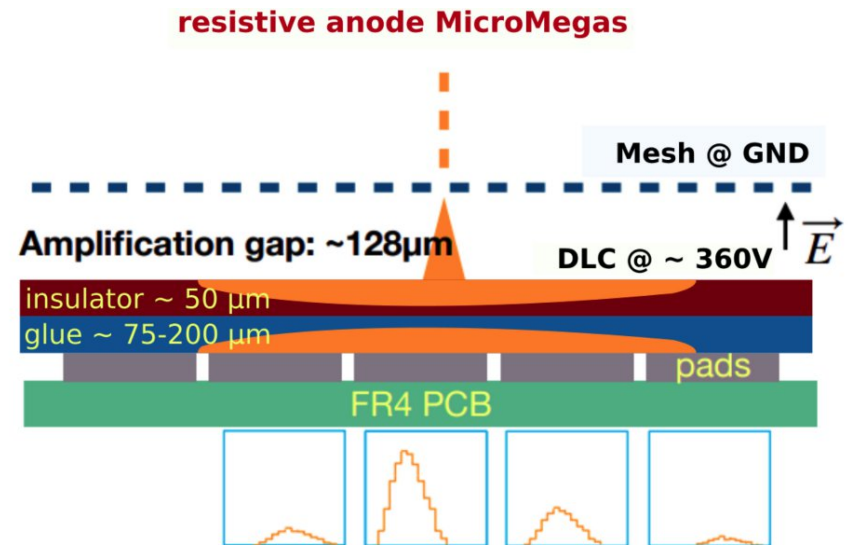
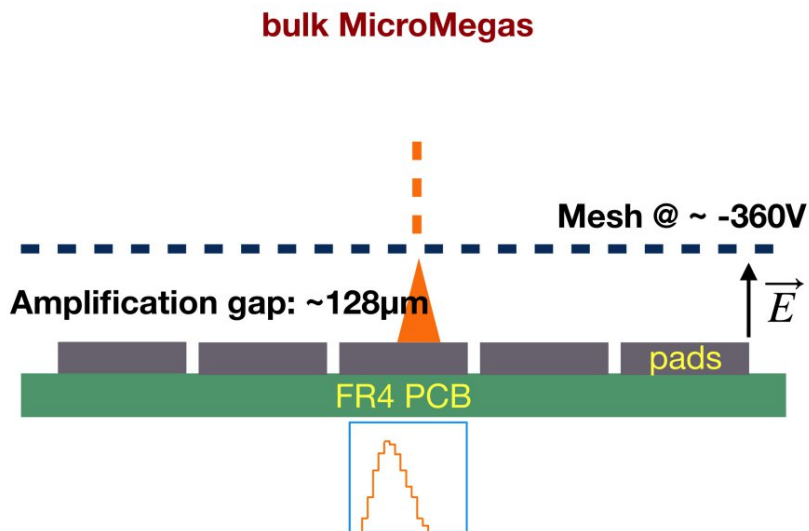
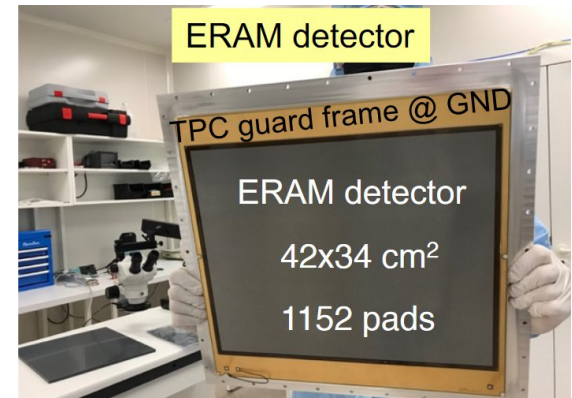

Micromegas signal

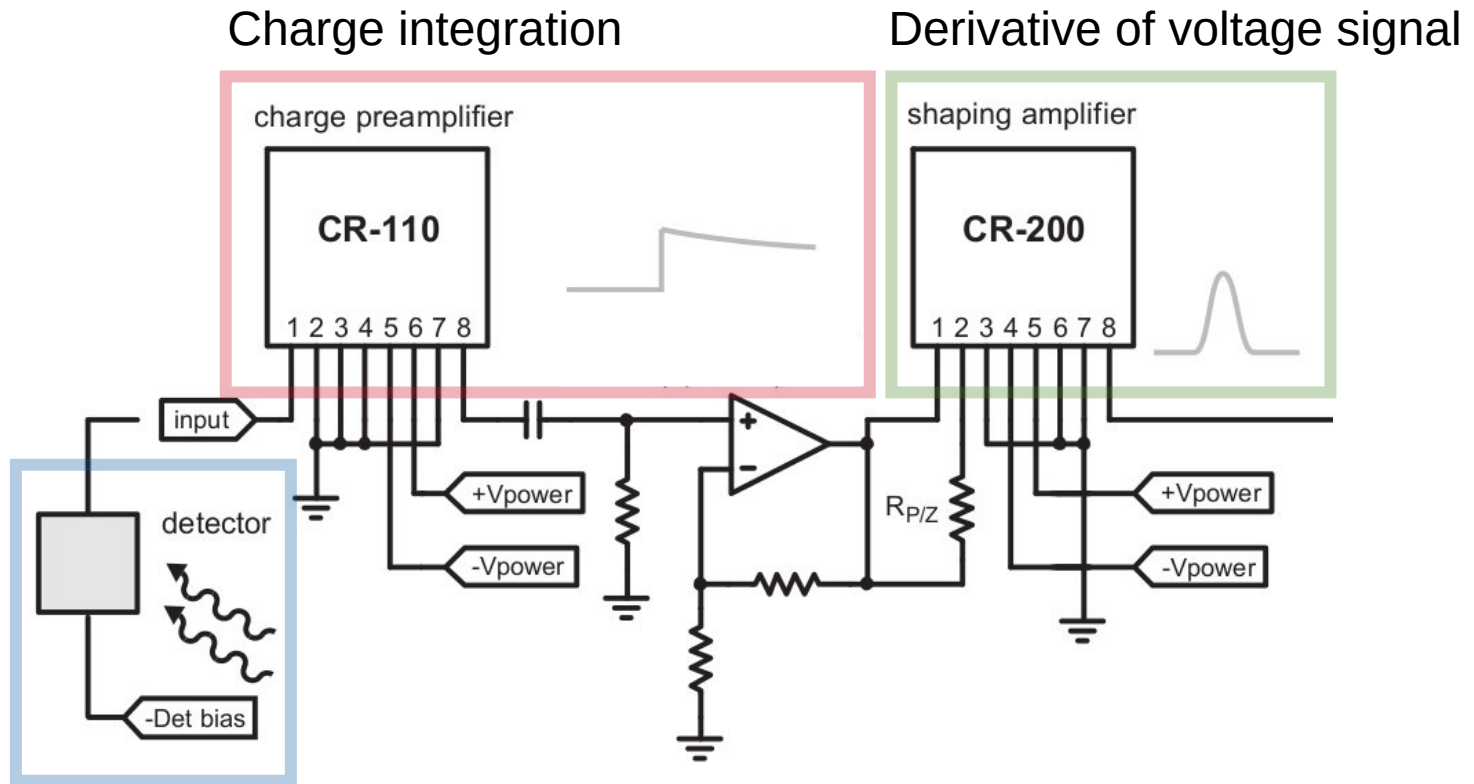

Signal of several 1000 electrons

General idea for GMCs

- Choice of materials (PEEK, POM, G10, ...)
 - Radiation hardness, halogen free
 - Low outgassing
- Modular approach
 - Make anode easily replaceable / upgradable
 - Rack-mountable system

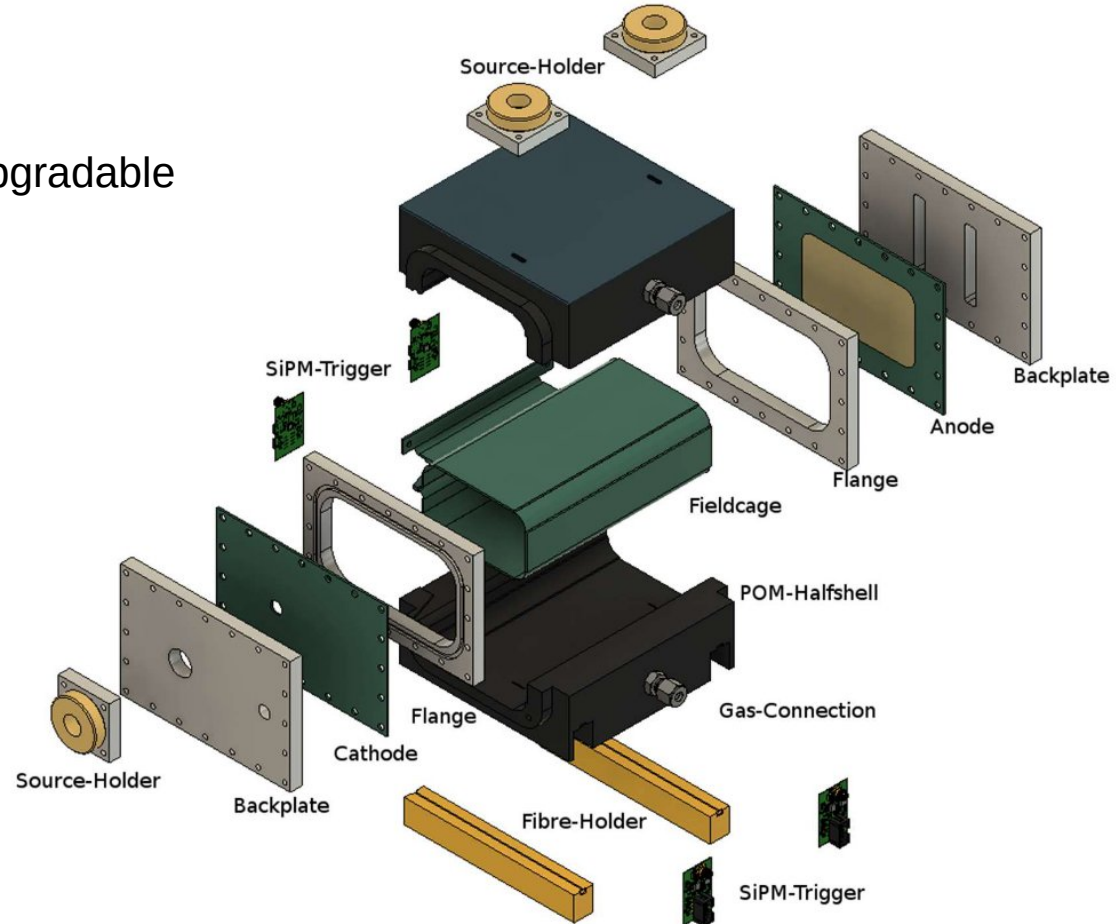
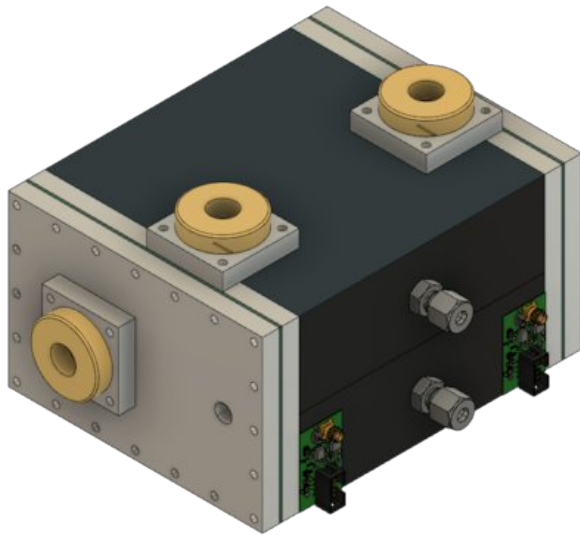

Interesting databases / material information

Starting points (!) for "material selections"?

- <https://outgassing.nasa.gov/outgassing-data-table>
- <https://www.ensingerplastics.com/en/plastic-material-selection/radiation-resistant>
- <https://www.klebeprofi.net/klebe-anleitungen/>
- <https://www.matweb.com/>
- <https://www.nist.gov/srd/physics>

- <http://cyclotron.mit.edu/drift/www/>

- https://ncsx.pppl.gov/NCSX_Engineering/Materials/VacuumMaterials/Outgassing_Data.pdf

- Database of databases would be really useful!

Setup at CERN

