

2023 beam test of μ RGroove and plan of 2024

Tian Xiangqi, He Siqi, Zhou Yi
State Key Laboratory of Particle Detection and Electronics
University of Science and Technology of China
2023.12.08

μ RGroove prototypes of 10cm \times 10cm



XY-readout μ RGroove

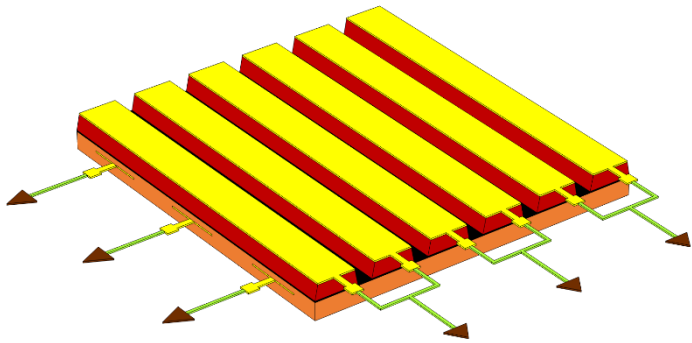

XYV-readout μ RGroove

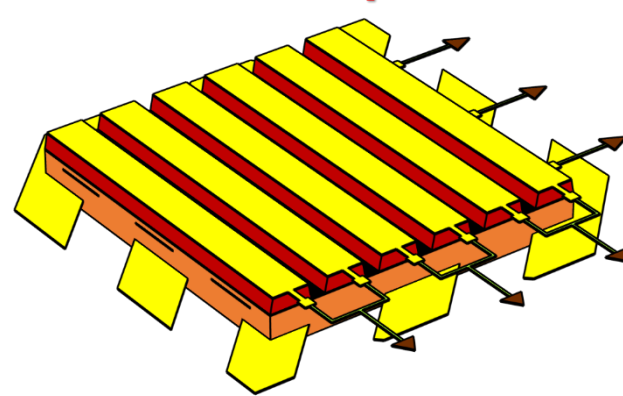

Drift electrode

μ RGroove PCB

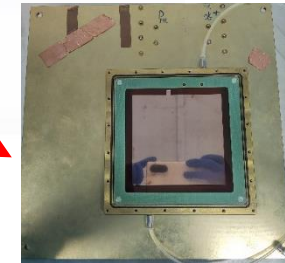
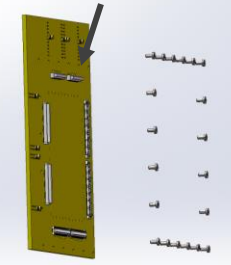
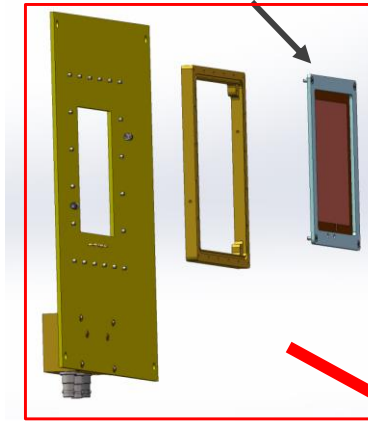

- The two prototypes have the same groove geometry but different readout structures.
- XY- μ RGroove has only one layer of readout strip
- XYV is designed for evaluating the spatial resolution of XV readout

Beam Test setup

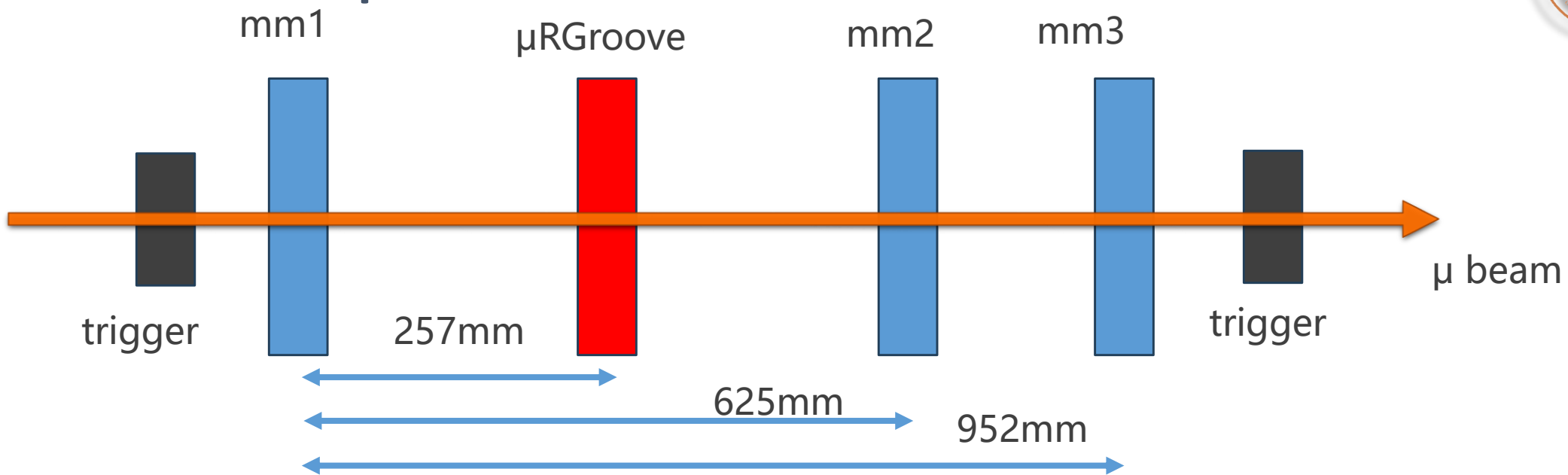

Ar:iC4H10 = 95:5
(μRGroove)

mmDAQ+SRS+APV25

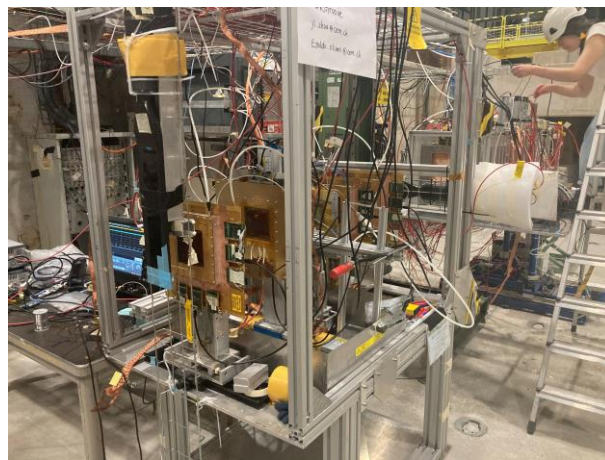

Preliminary result of beam test

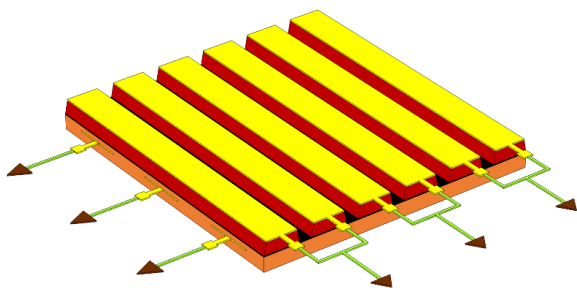

2D Anode scan

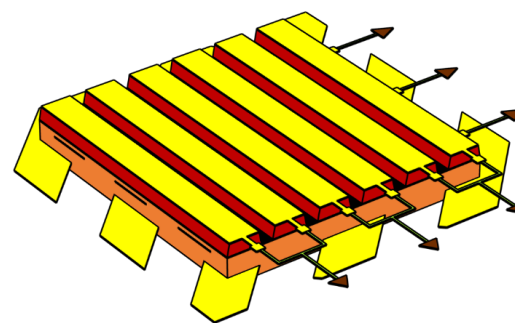

3D Anode scan

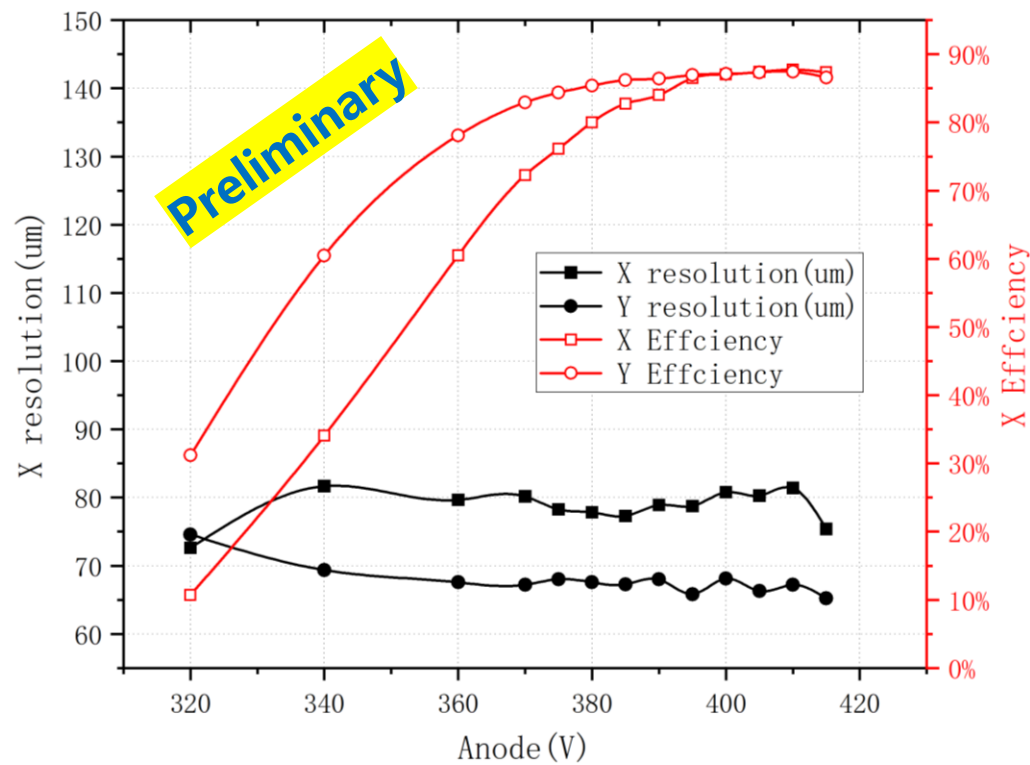
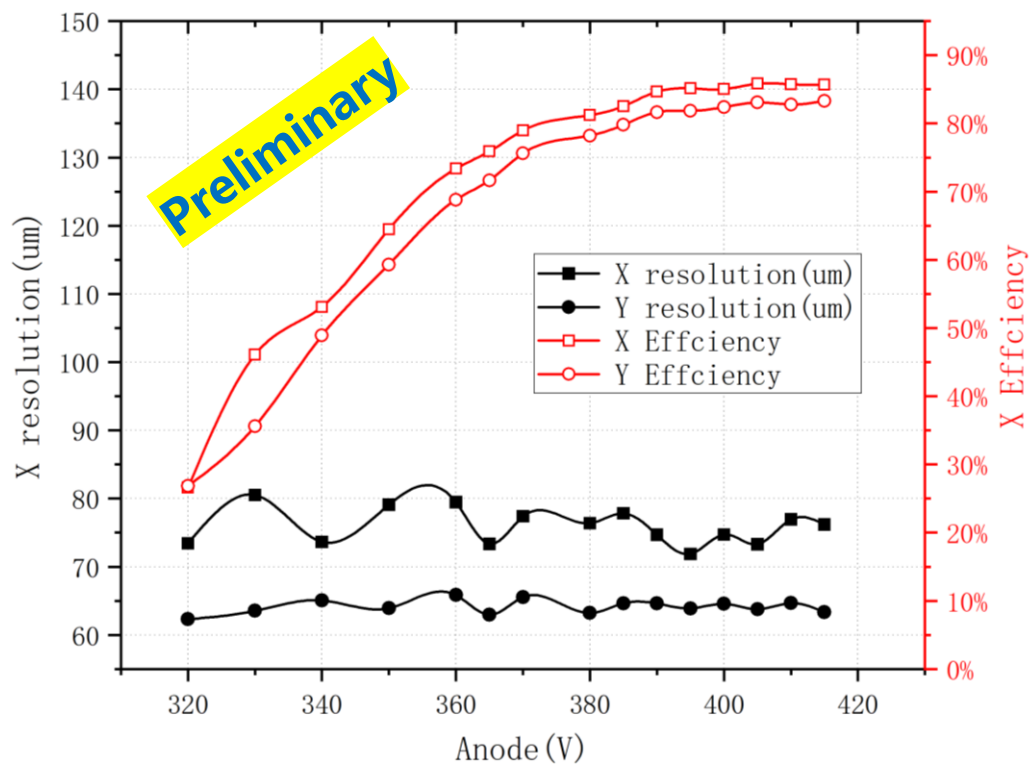

Test plan of 2024



Detector Group1(No magnet needed):

- 10cm×10cm μ RGroove ×4
Used for as the tracker of c- μ RWELL/c- μ RGroove
- 50cm×50cm μ RGroove ×1
Used for the study of μ RGroove rate capability
- 50cm×50cm μ RWELL ×2
Used for the study of large area high rate μ RWELL

Detector Group2(Magnet needed):

- c- μ RWELL/c- μ RGroove
R&D of STCF inner tracker

Request to RD51: Detector Group1

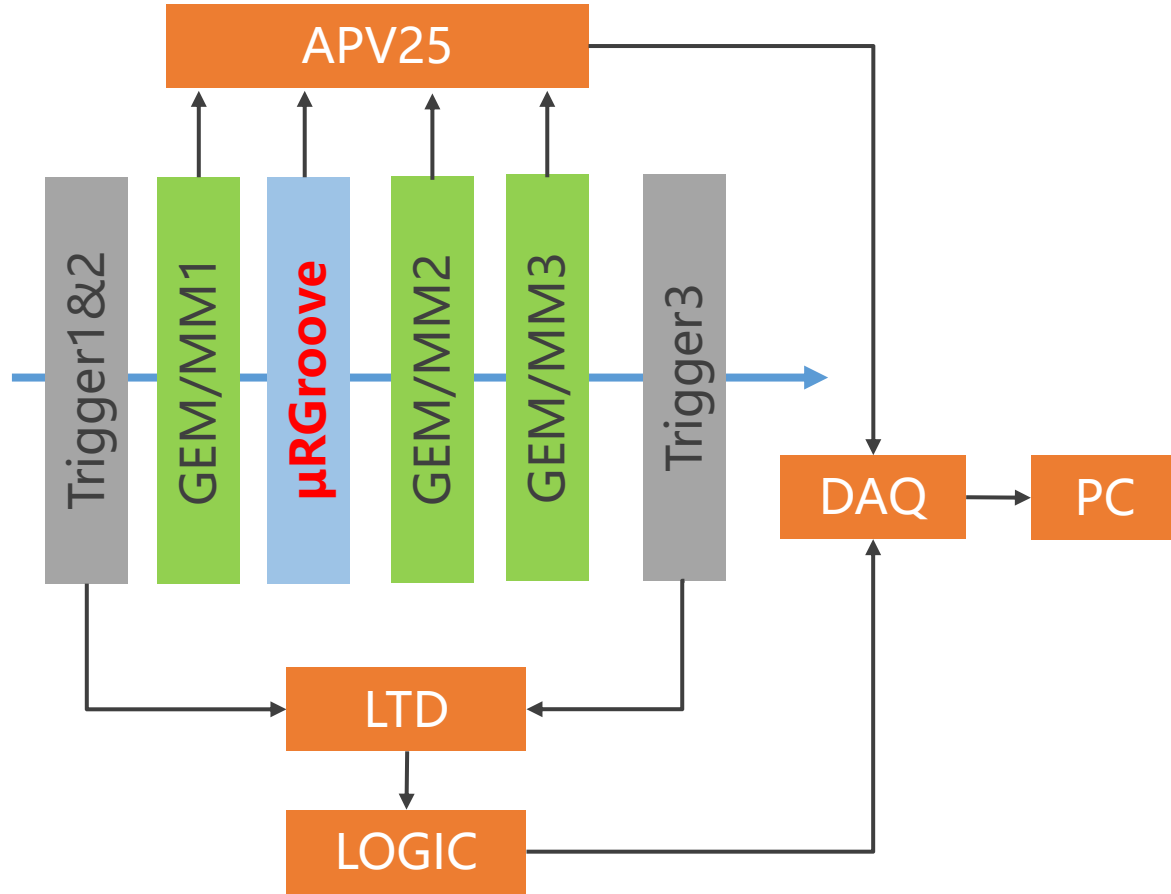

Telescope:

- GEM or MM Tracker
- 3 scintillators for trigger

Electronics:

- APV25 FEE \times 12 for Tracker
- APV25 FEE \times 4 for test detectors

Gas:

- Ar:CO₂ 70:30/93:7 for GEM/MM
- Ar:iC₄H₁₀ 95:5 for μ RWELL/ μ RGroove

Expected beam time:

- 1st beam in 2024
- 2nd beam in 2024

Request to RD51: Detector Group2

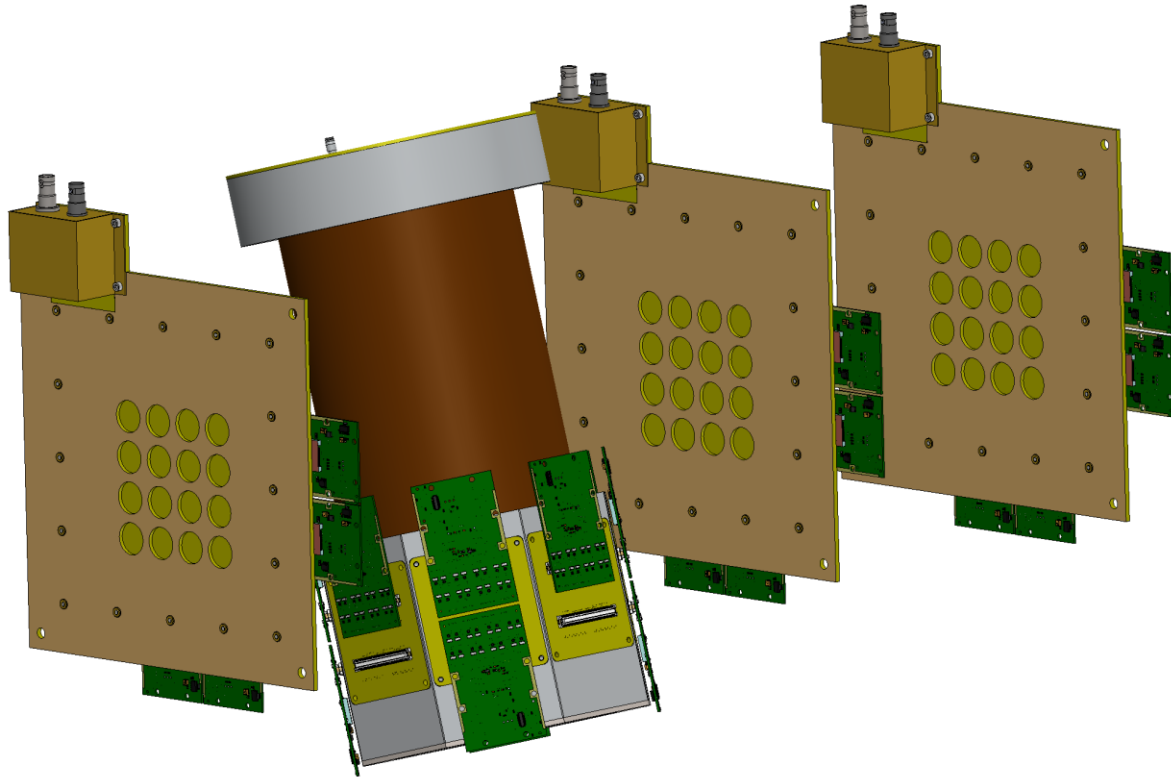

Electronics:

- APV25 FEE × 12 for μ RGroove Tracker
- APV25 FEE × 6 for c- μ RWELL/c- μ RGroove

Gas:

- Ar:iC₄H₁₀ 95:5 for all detectors

Expected beam time:

- 2nd beam in 2024
- 3rd beam in 2024

- **We will use μ RGroove tracker, it is still under building;**
- **We need magnet, and we will remotely control the rotation of the detector;**
- **The real beam test time depends on the progress of detector & tracker manufacture;**

THANKS!

Backup



大学技术

2D uRGroove

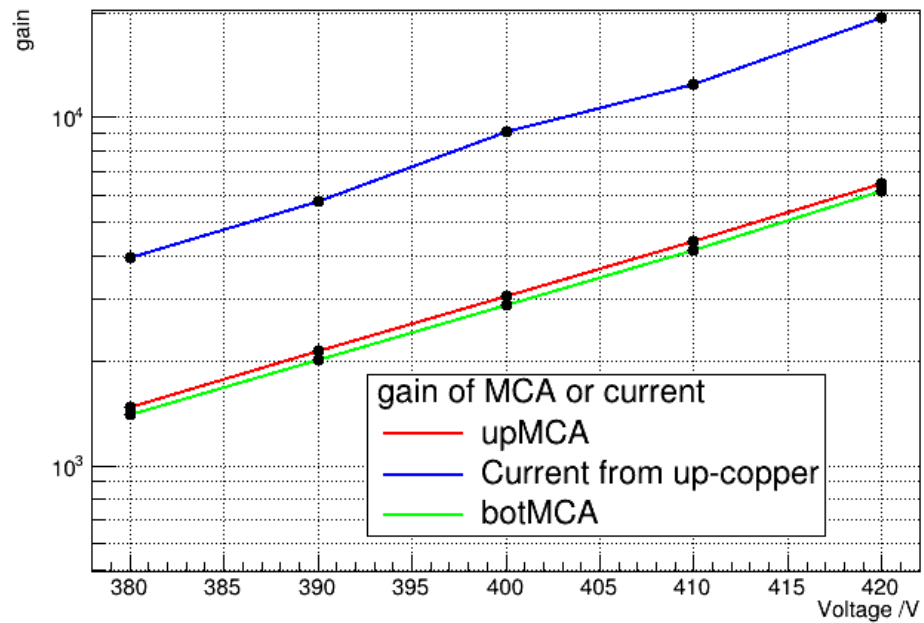

stability

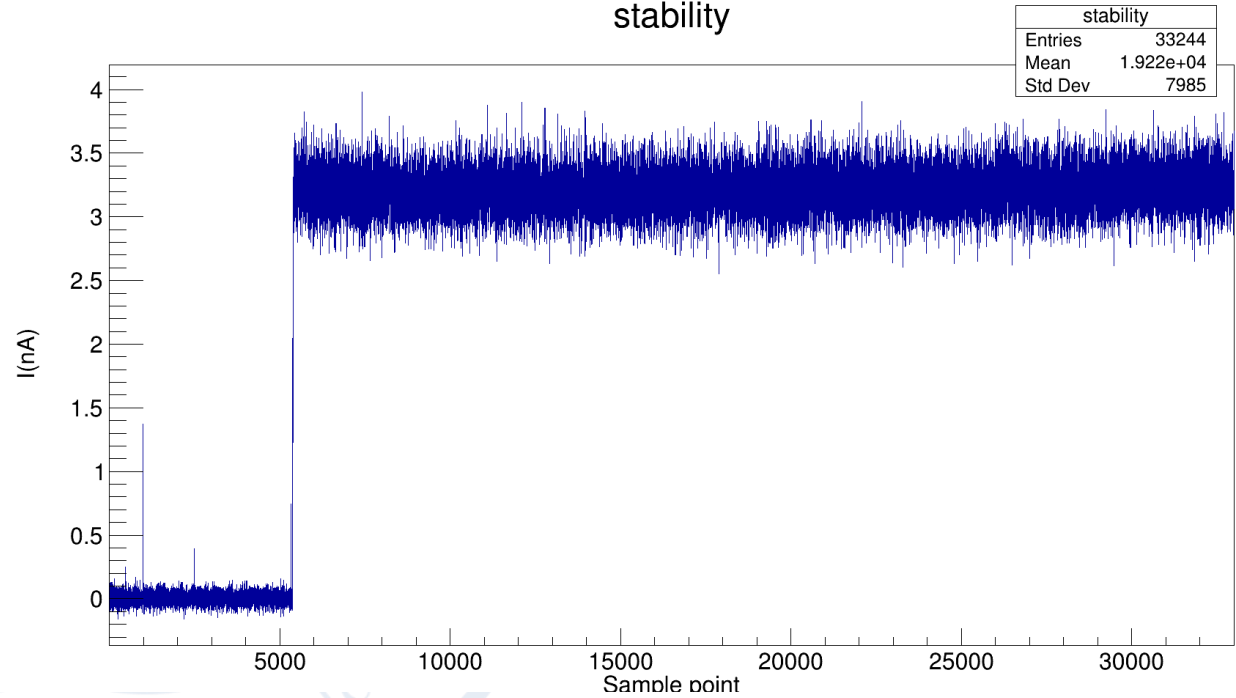

Science and Technology