



FUNDAMENTOS DE CIÊNCIA & CIÊNCIA FUNDAMENTAL



André David (CERN)



3

Things you can't "unsee"

[<http://cern.ch/go/Dxh7>]



Things you can't "unsee"



4

[<http://cern.ch/go/Dxh7>]





Things you can't "unsee"

[<http://cern.ch/go/Dxh7>]



Como o bóson de Higgs

6

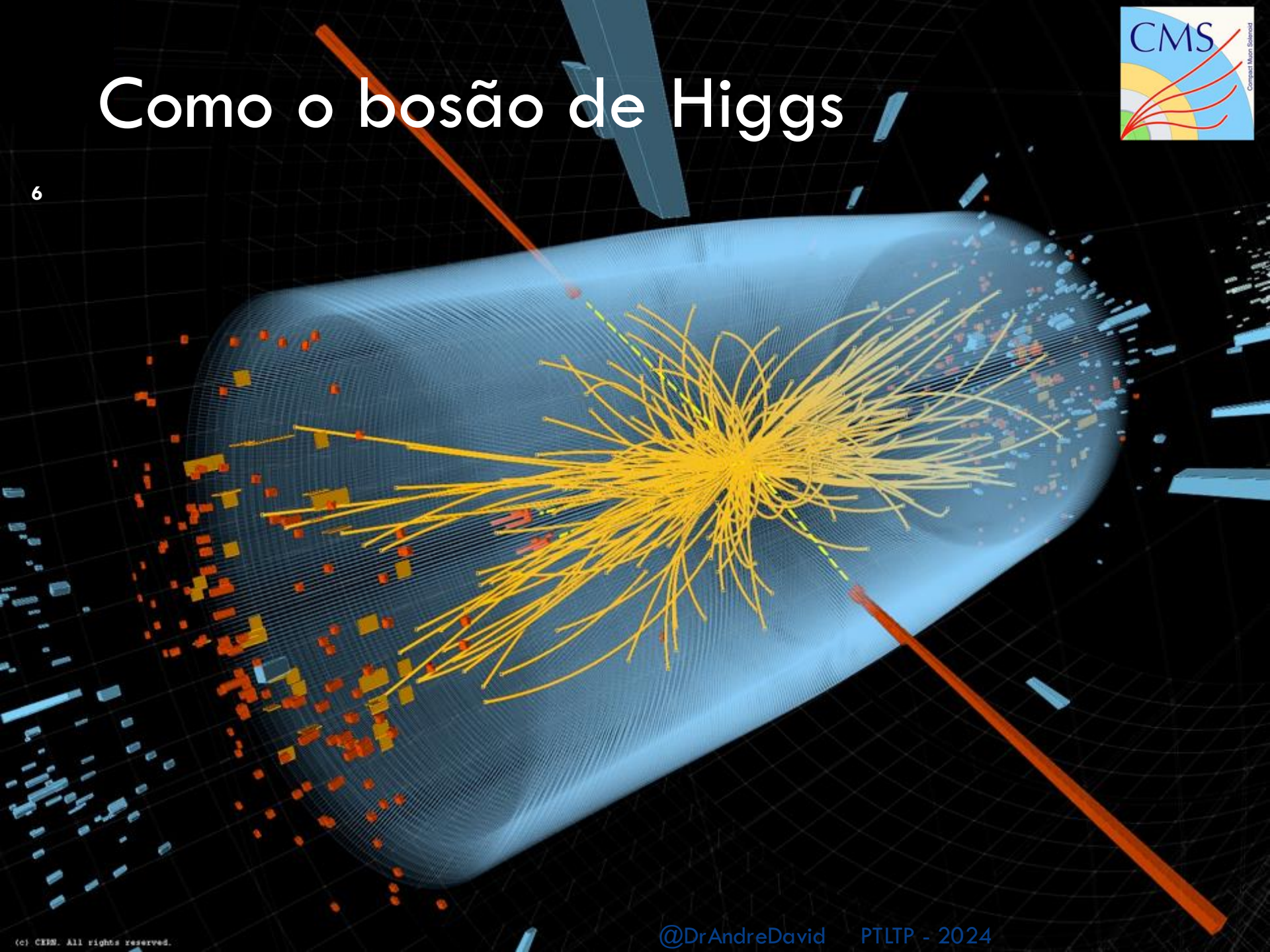

7 O papel dos experimentalistas



Natureza



Natureza



Teoria

Natureza

Teoria

Teóricos
(dentro)

Natureza

Teoria

Fenomenologistas

Teóricos
(dentro)



Natureza



Natureza



Teoria



Fenomenologistas



Teóricos
(dentro)

Natureza

Experimentalistas

Natureza

Teoria

Fenomenologistas

Teóricos
(dentro)

Natureza

Experimentalistas
com mais
experiência

Experimentalistas

Natureza

Teoria

Fenomenologistas

Teóricos
(dentro)

16

Lógica (“formal” e “da batata”)

Ou como decidir que experiências fazer.



Wason selection task

17

[https://en.wikipedia.org/wiki/Wason_selection_task]

- “You are shown a set of four cards placed on a table, each of which has a number on one side and a colored patch on the other side. The visible faces of the cards show 3, 8, red and brown. **Which card(s) must you turn over in order to test the truth of the proposition that if a card shows an even number on one face, then its opposite face is red?”**

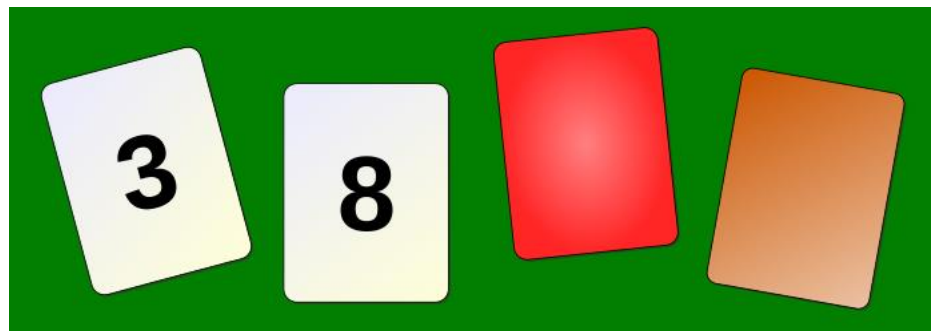

Wason selection task

- “Há quatro cartas na mesa, cada uma com um número num lado e uma cor no outro. Podemos ver um 3, um 8, uma vermelha, e uma castanha. **Que carta(s) têm que ser viradas de forma a testar a veracidade da proposição que se uma carta tem um número par de um lado, então a cor do outro lado é vermelho?**”

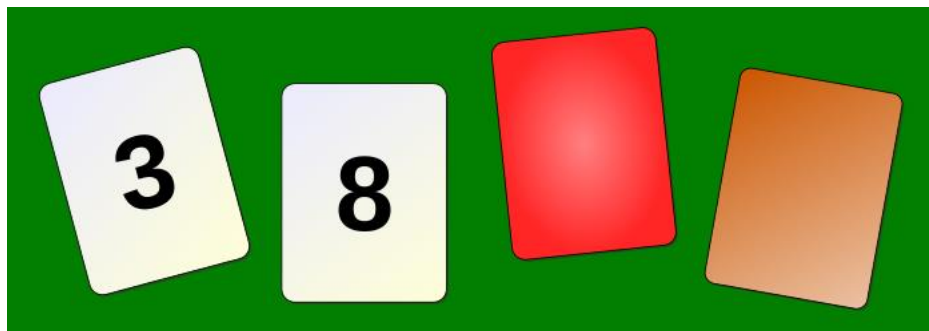



Trocado por miúdos

- Como testar a ideia que “**par** \Rightarrow **vermelho**”?

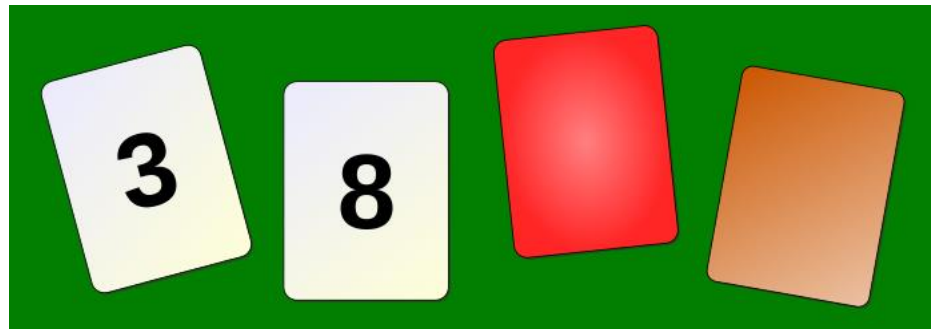



Lógica (formal)

20

- $A \Rightarrow B$
- Ou seja:
par \Rightarrow vermelho

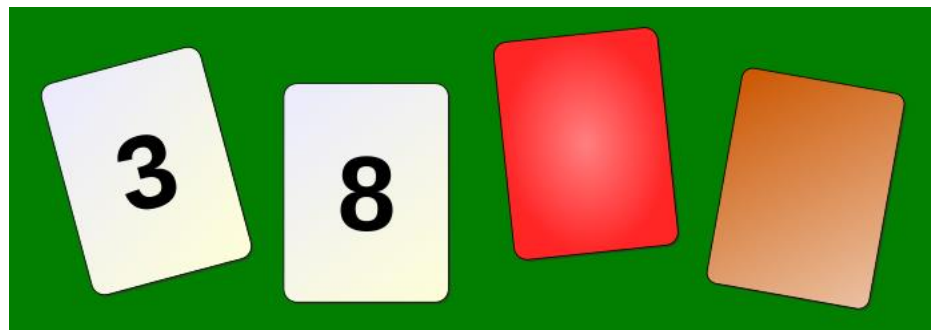



Lógica (formal)

21

- $A \Rightarrow B \Leftrightarrow \neg B \Rightarrow \neg A$.
- Ou seja:
par \Rightarrow vermelho \Leftrightarrow não-vermelho \Rightarrow não-par.

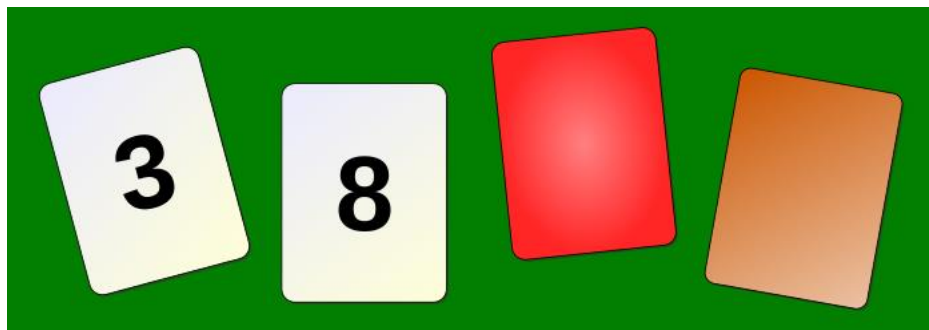



Lógica (da batata)

□ $\text{par} \Rightarrow \text{vermelho}$

\Leftrightarrow

$\text{não-vermelho} \Rightarrow \text{não-par.}$

□ O que é que a regra implica para cada uma das cartas?

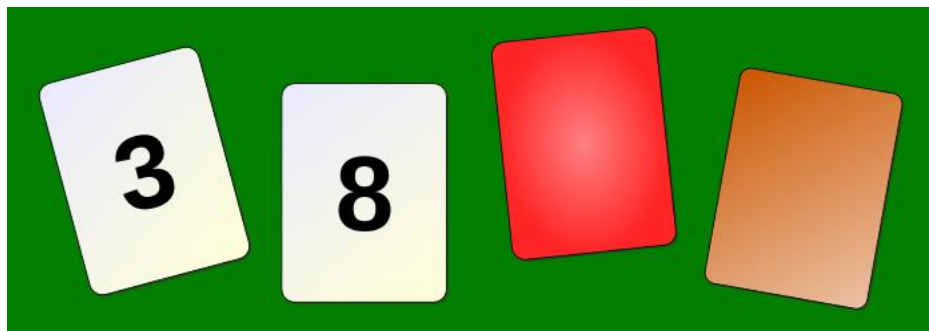

23

Respeitar a incerteza

A importância da incerteza

[<http://observador.pt/especiais/transplante-de-medula-ossea-um-novo-e-grande-incentivo/>]

A taxa de sucesso em Portugal foi maior que a média europeia



Fonte: Gabinete de Promoção do Programa Quadro de I&DT/Ministério da Educação e Ciência



A importância da incerteza

25

[<http://observador.pt/especiais/transplante-de-medula-ossea-um-novo-e-grande-incentivo/>]

A taxa de sucesso em Portugal foi maior que a média europeia

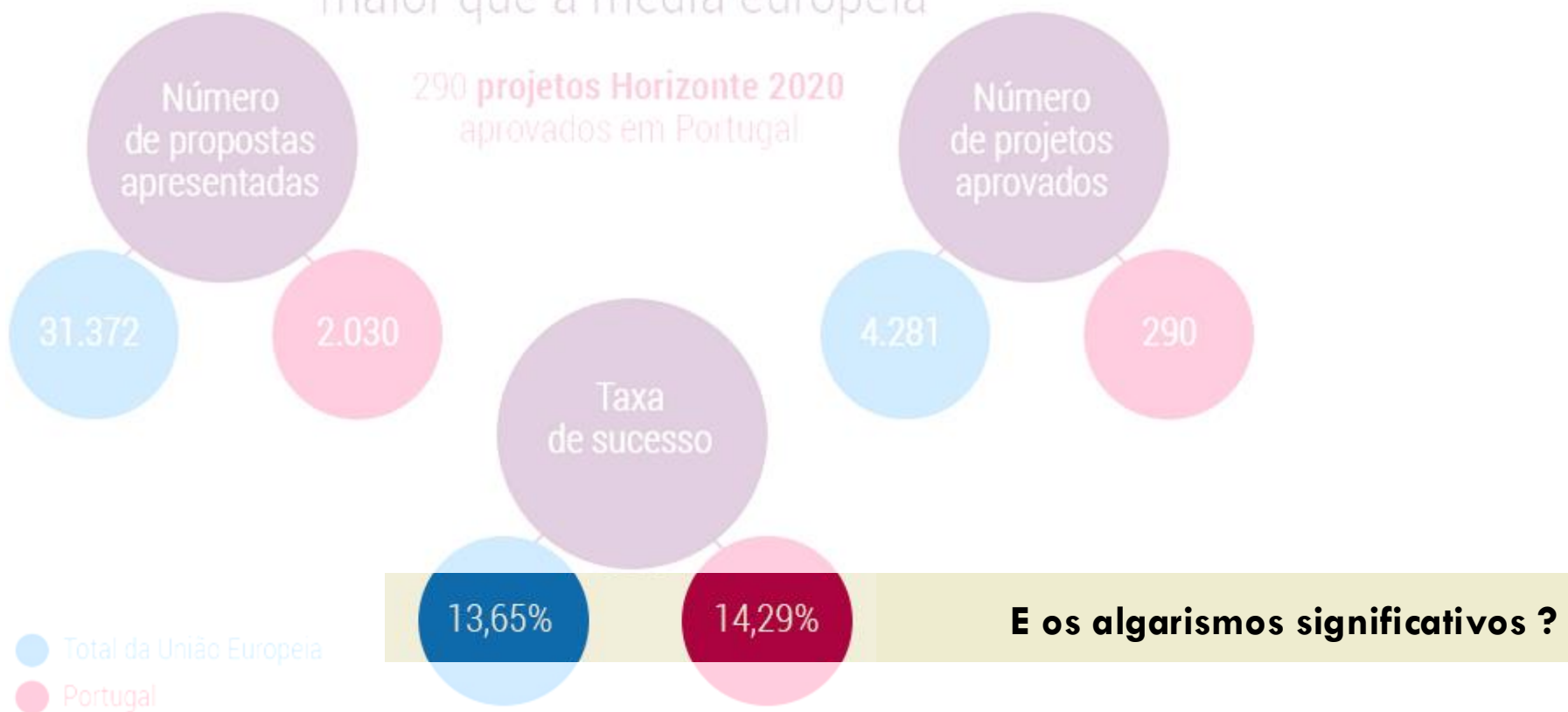

Fonte: Gabinete de Promoção do Programa Quadro de I&DT/Ministério da Educação e Ciência



A importância da incerteza

26

[<http://observador.pt/especiais/transplante-de-medula-ossea-um-novo-e-grande-incentivo/>]

A taxa de sucesso em Portugal foi maior que a média europeia

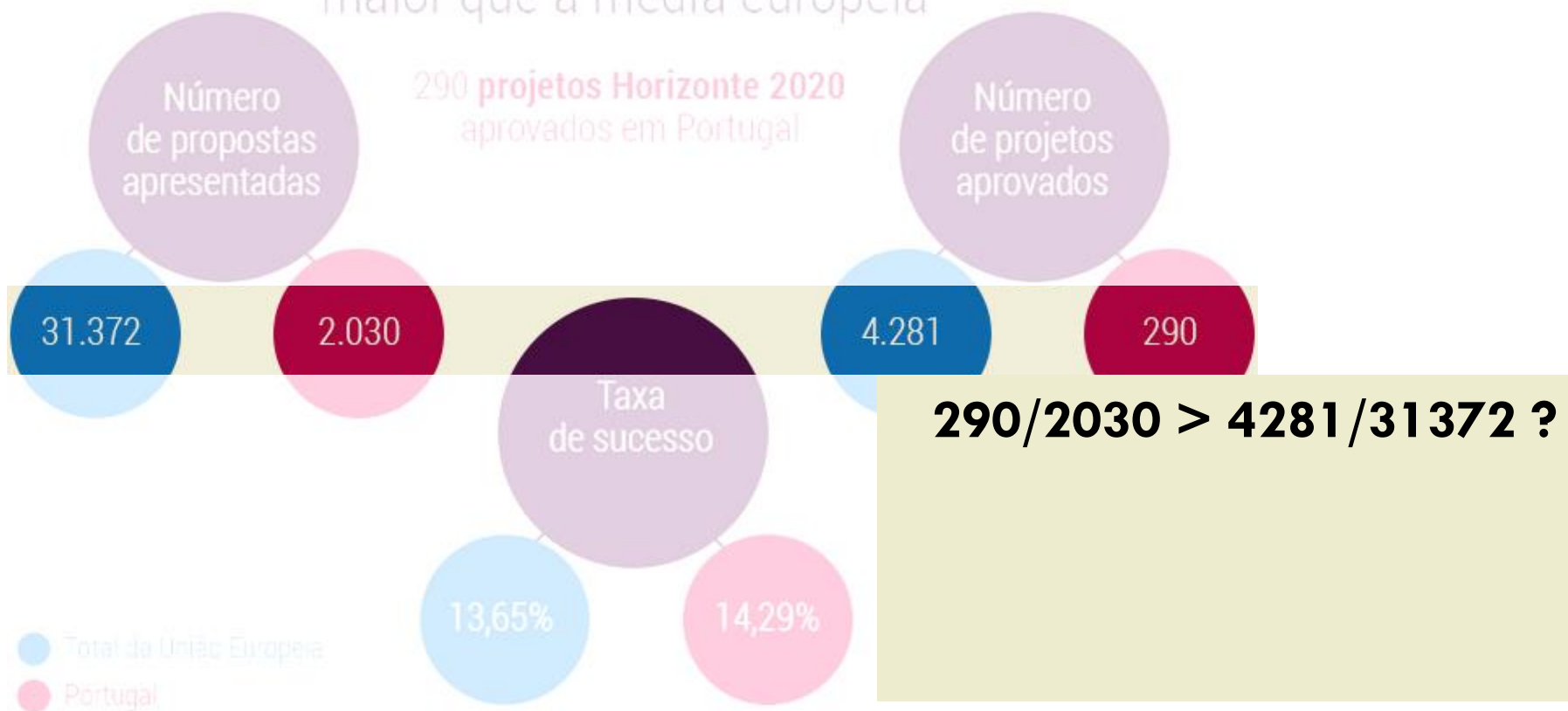

Fonte: Gabinete de Promoção do Programa Quadro de I&DT/Ministério da Educação e Ciência



A importância da incerteza

[<http://observador.pt/especiais/transplante-de-medula-ossea-um-novo-e-grande-incentivo/>]

A taxa de sucesso em Portugal foi maior que a média europeia

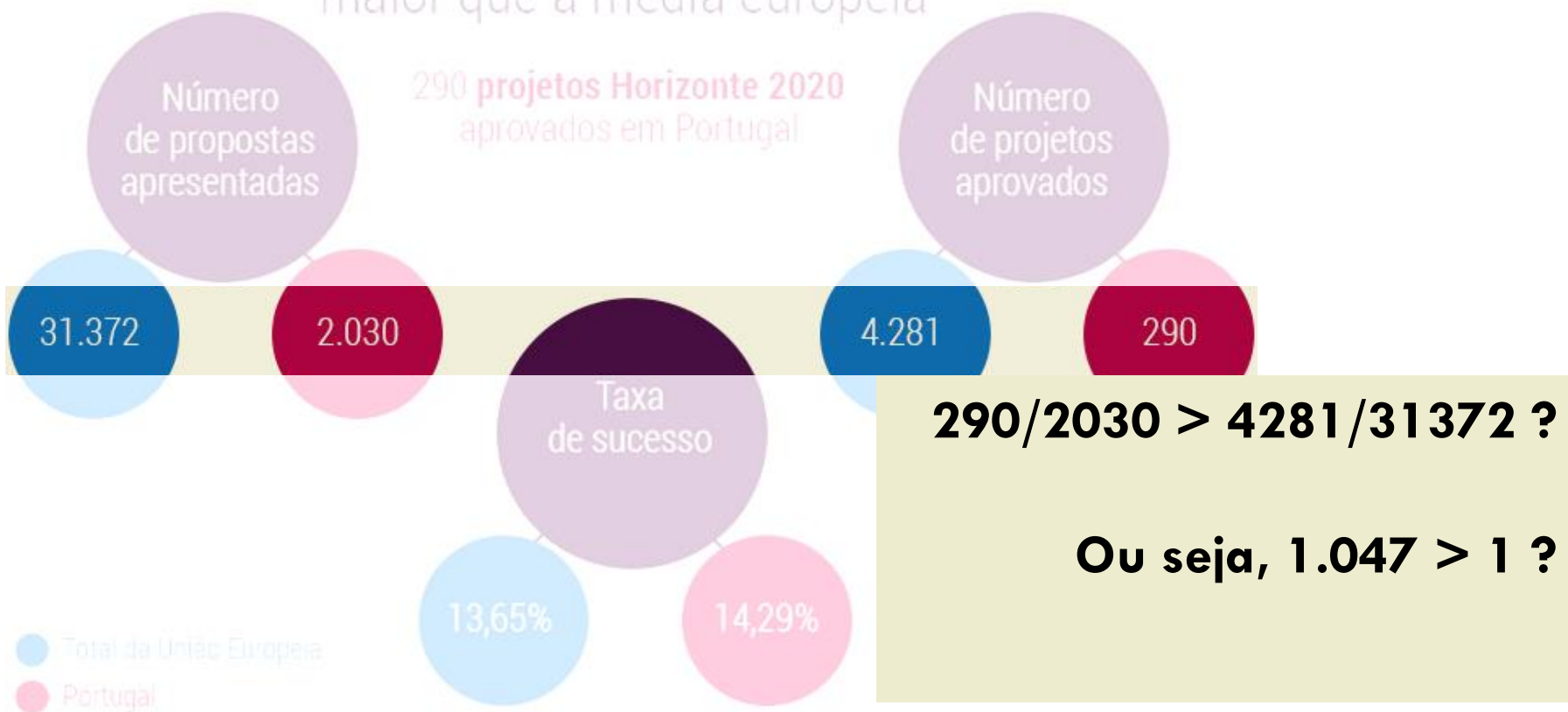

Fonte: Gabinete de Promoção do Programa Quadro de I&DT/Ministério da Educação e Ciência



A importância da incerteza

28

[<http://observador.pt/especiais/transplante-de-medula-ossea-um-novo-e-grande-incentivo/>]

\$ R

```
R version 3.2.2 (2015-08-14) -- "Fire Safety"
Copyright (C) 2015 The R Foundation for Statistical Computing
Platform: x86_64-apple-darwin14.5.0 (64-bit)
```

```
> library("rateratio.test")
> rateratio.test(c(290,4281),c(2030,31372),conf.level=0.90,alternative="greater")
```

Exact Rate Ratio Test, assuming Poisson counts

```
data: c(290, 4281) with time of c(2030, 31372), null rate ratio 1
```

p-value = 0.2331

alternative hypothesis: true rate ratio is greater than 1

90 percent confidence interval:

0.9664013 Inf

sample estimates:

Rate Ratio	Rate 1	Rate 2
1.0468849	0.1428571	0.1364593

A taxa de sucesso em Portugal foi maior que a média europeia



Fonte: Gabinete de Promoção do Programa Quadro de I&DT/Ministério da Educação e Ciência

A importância da incerteza

[<http://observador.pt/especiais/transplante-de-medula-ossea-um-novo-e-grande-incentivo/>]

A taxa de sucesso em Portugal foi **basicamente a mesma** ~~maior~~ que a média europeia



Fonte: Gabinete de Promoção do Programa Quadro de I&DT/Ministério da Educação e Ciência

Um final feliz: artigo actualizado

30

[<http://observador.pt/especiais/transplante-de-medula-ossea-um-novo-e-grande-incentivo/>]

A **taxa de sucesso** em Portugal está em linha com a média europeia



Fonte: Gabinete de Promoção do Programa Quadro de I&DT/Ministério da Educação e Ciência

31

Exactidão e precisão

Erros e incerteza



Dicas sobre exactidão e *precisão*









37

Erros não são incertezas

Dicas sobre erro e incerteza

- **Erro:** o resultado de um **desvio** ou de uma **incorrecção**.
- **Incerteza:** o quão não se conhece algo.
- ***É incorrecto chamar erros às incertezas.***
- E.g., os experimentalistas corrigem erros sistemáticos.
 - ▣ E essas correcções adicionam incerteza às medidas.

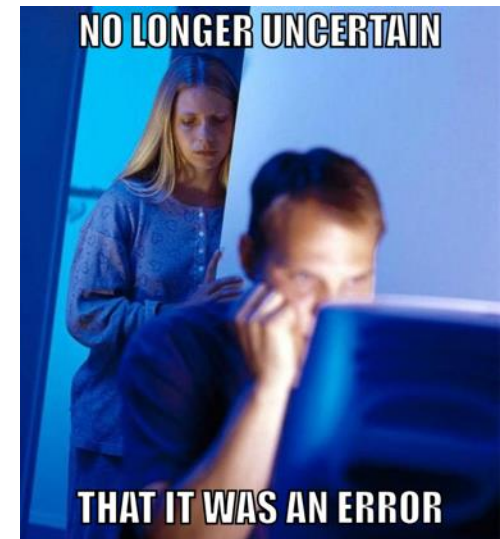

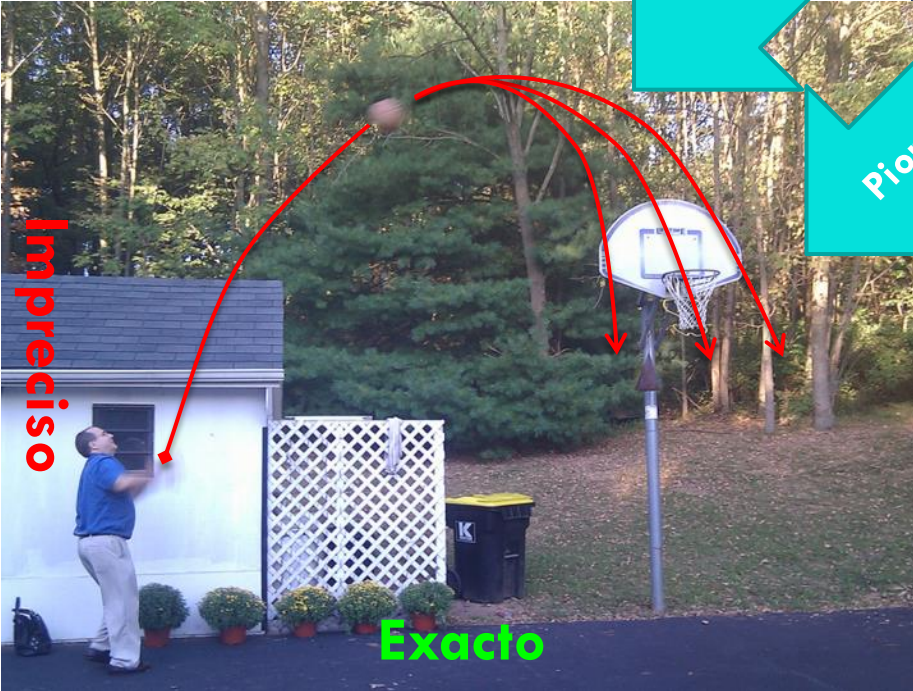
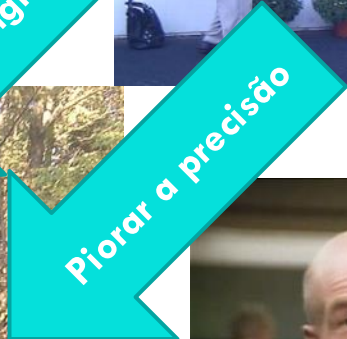

40

“Água mole em pedra dura...”

Ou o preço de procurar coisas novas.

Significant – xkcd.com/882



41

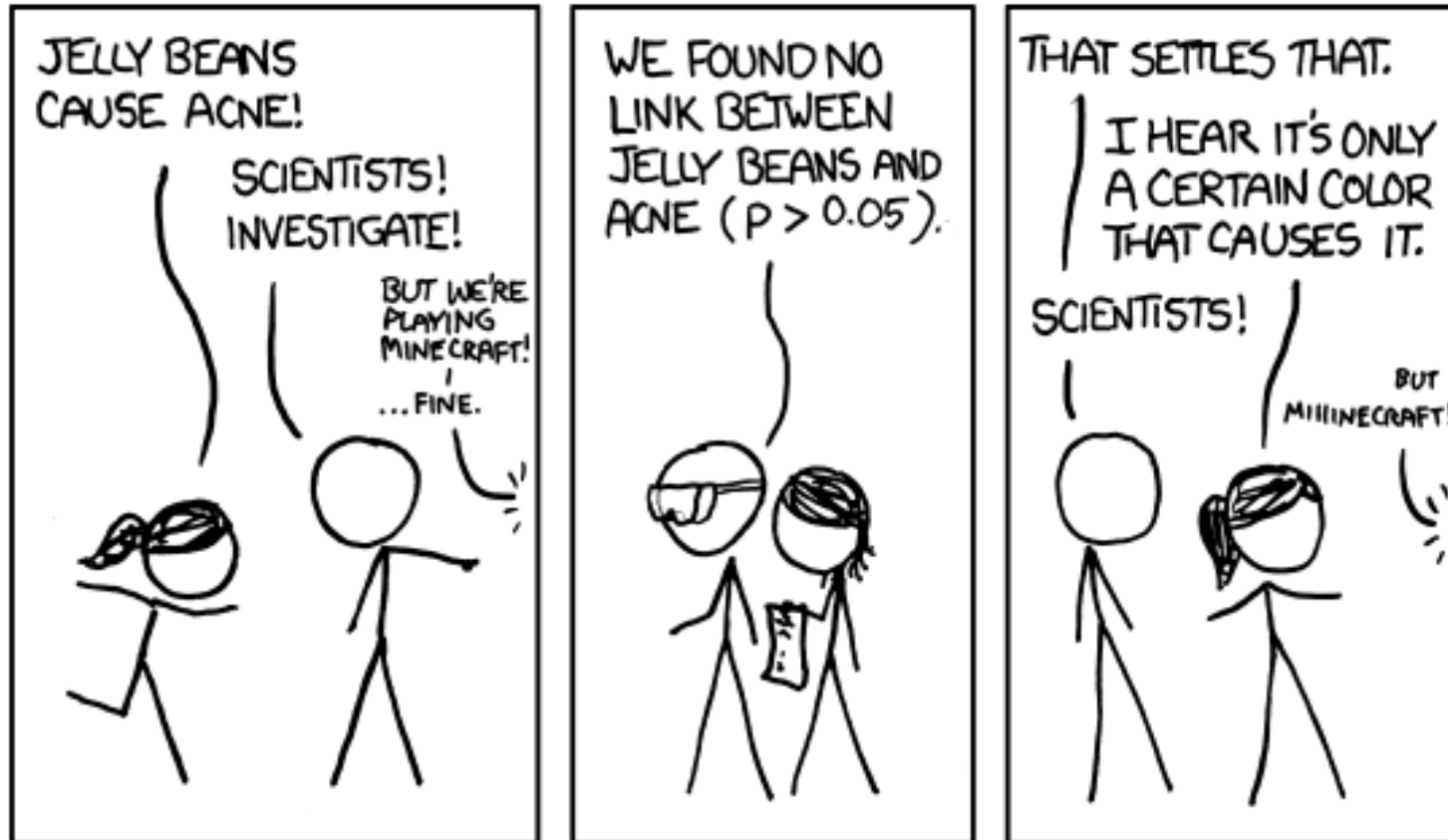

Significant – xkcd.com/882



42

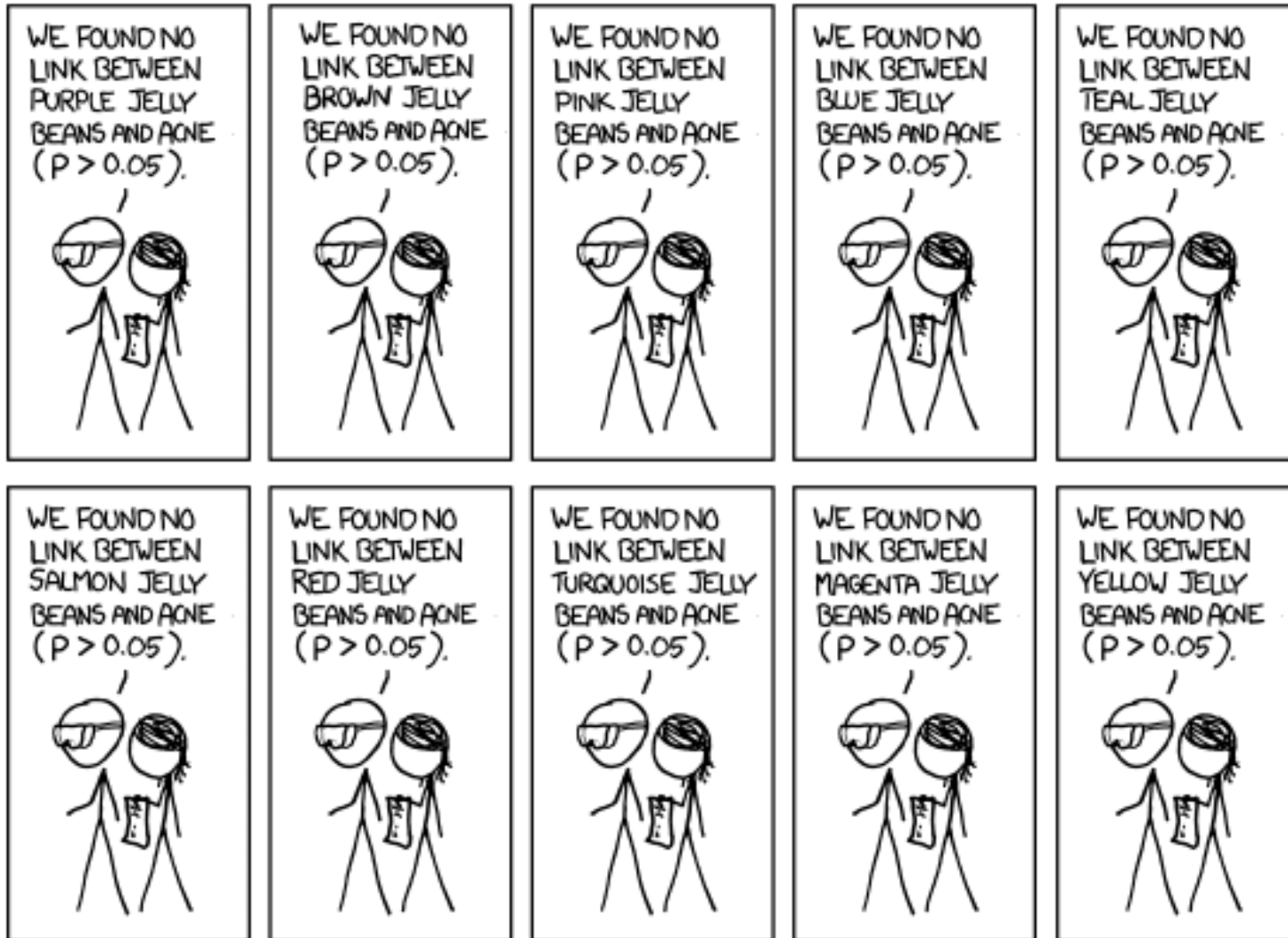

Significant – xkcd.com/882



43

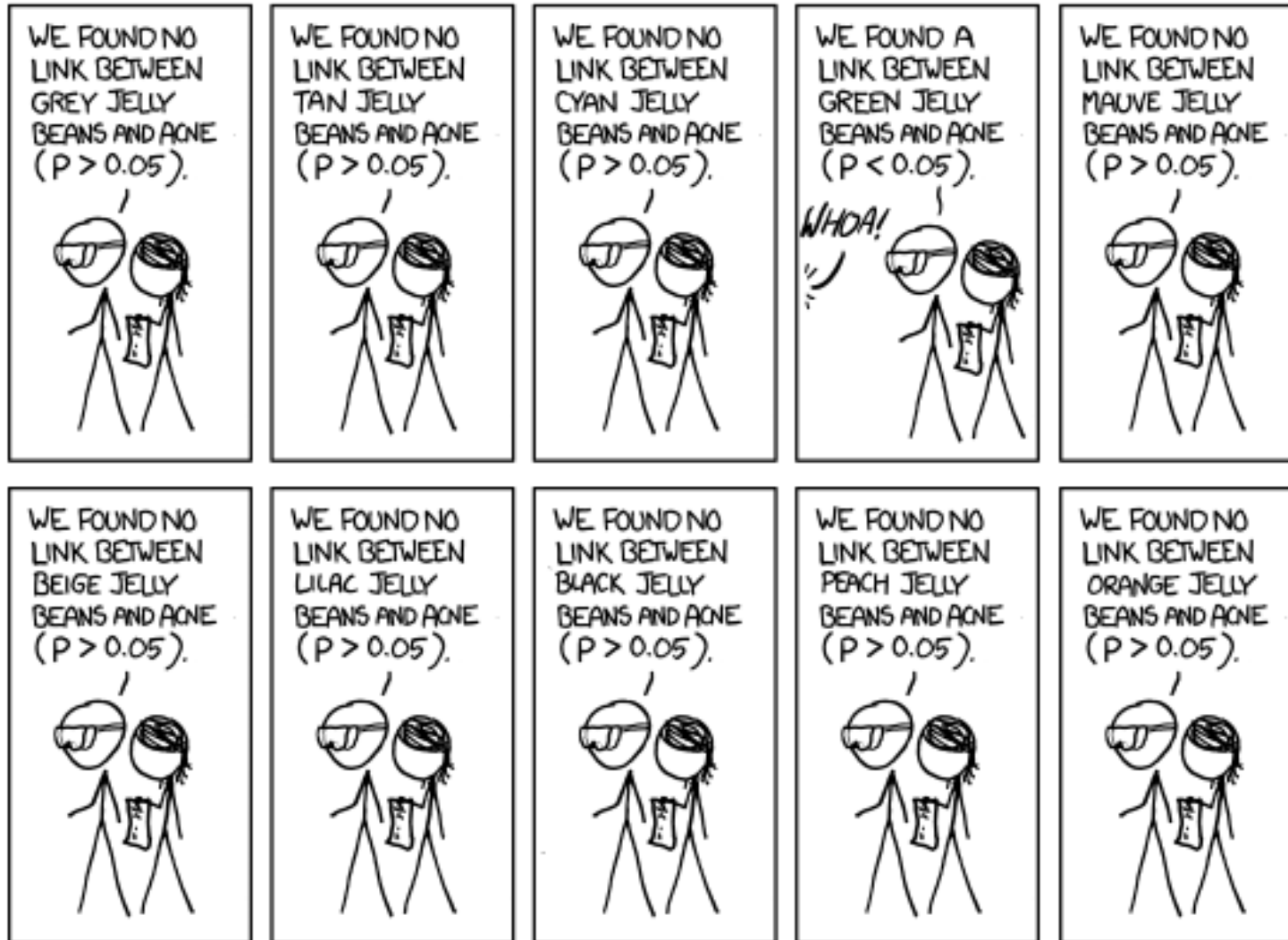

Significant – xkcd.com/882

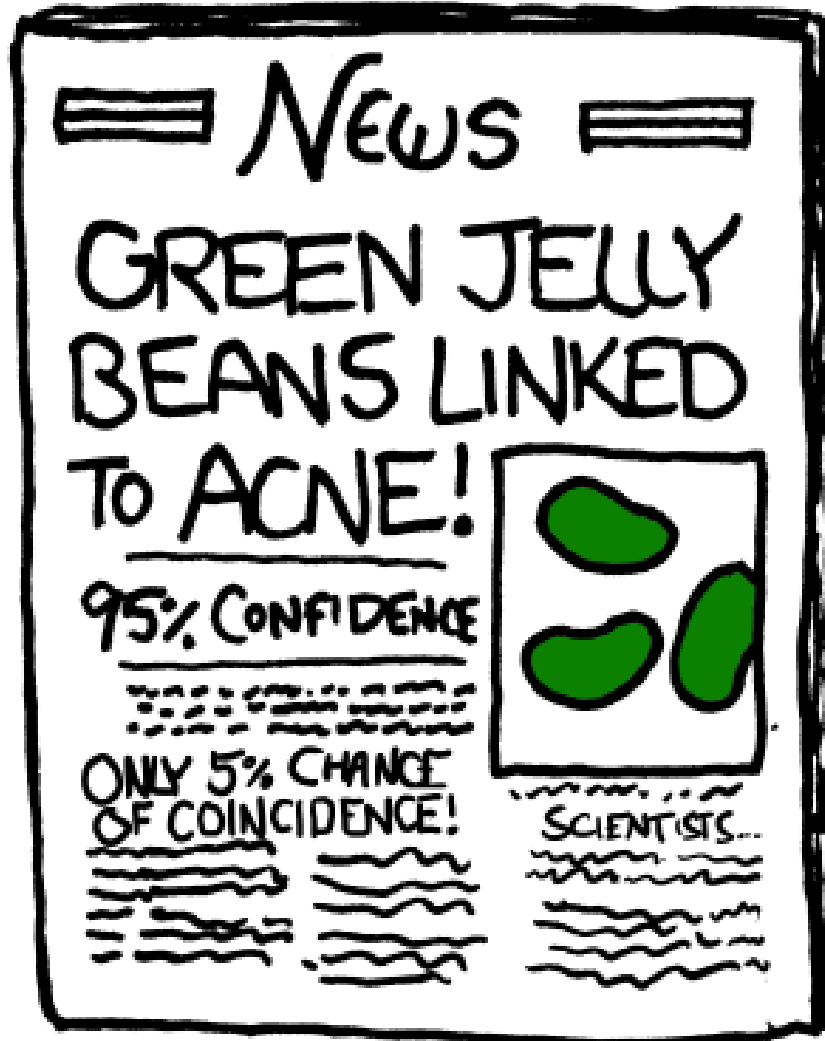



Uma proposta irrecusável

- Mandei-te previsões correctas para comprar ou vender no mercado accionista todas as semanas durante as últimas 10 semanas.



Uma proposta irrecusável

- Mandei-te previsões correctas para comprar ou vender no mercado accionista todas as semanas durante as últimas 10 semanas.
 - Qual é a probabilidade de isto acontecer por acaso?

Uma proposta irrecusável

- Mandei-te previsões correctas para comprar ou vender no mercado accionista todas as semanas durante as últimas 10 semanas.
 - ▣ Qual é a probabilidade de isto acontecer por acaso?
- Obviamente deves mandar-me 1000€ para eu os investir por ti.
 - ▣ Certo?



Uma proposta irrecusável

- Mandei-te previsões correctas para comprar ou vender no mercado accionista todas as semanas durante as últimas 10 semanas.
 - ▣ Qual é a probabilidade de isto acontecer por acaso?
- Obviamente deves mandar-me 1000€ para eu os investir por ti.
 - ▣ Certo?

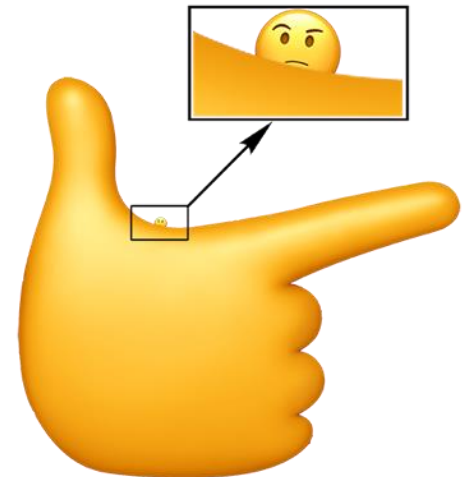

Qual é o denominador/contexto?

[https://en.wikipedia.org/wiki/Survivorship_bias]

- Survivorship bias.
 - “the parapsychology researcher Joseph Banks Rhine **believed he had identified the few individuals from hundreds of potential subjects who had powers of ESP.** His calculations were based on the improbability of these few subjects guessing”

- **Importante ao noticiar e ao comunicar.**

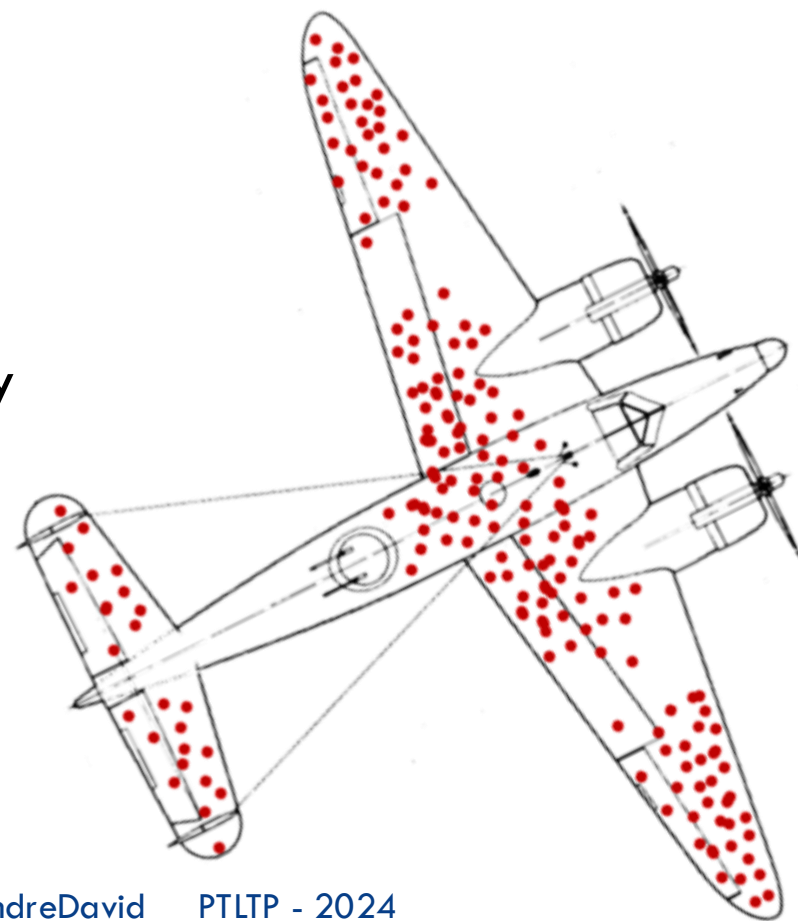

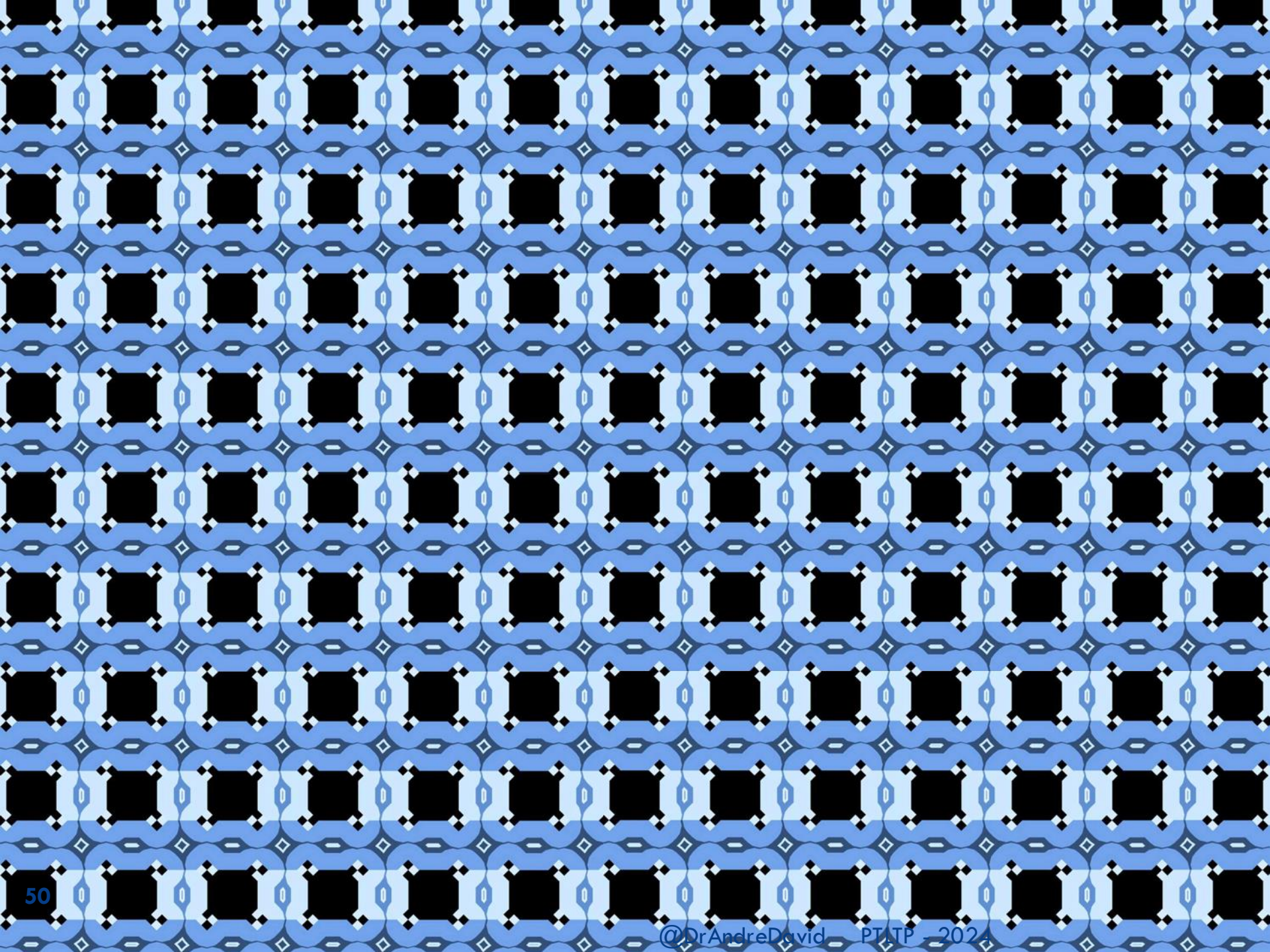

You can't unsee it

You can't unsee it

Os teóricos podem ver a próxima onda.

Os experimentalistas surfam as ondas.

You can't unsee it

Os teóricos podem ver a próxima onda.

Os experimentalistas surfam as ondas.

Conhecimento gera-se por exclusão.

You can't unsee it

Os teóricos podem ver a próxima onda.

Os experimentalistas surfam as ondas.

Conhecimento gera-se por exclusão.

Respeita a incerteza.

You can't unsee it

Os teóricos podem ver a próxima onda.

Os experimentalistas surfam as ondas.

Conhecimento gera-se por exclusão.

Respeita a incerteza.

Não confundas erros e incertezas.

You can't unsee it

Os teóricos podem ver a próxima onda.

Os experimentalistas surfam as ondas.

Conhecimento gera-se por exclusão.

Respeita a incerteza.

Não confundas erros e incertezas.

Quanto mais procurares, mais vais encontrar.

Qual foi o denominador?

The experimental method

falsifying theories since the dawn of reason

57

[opensource.com]

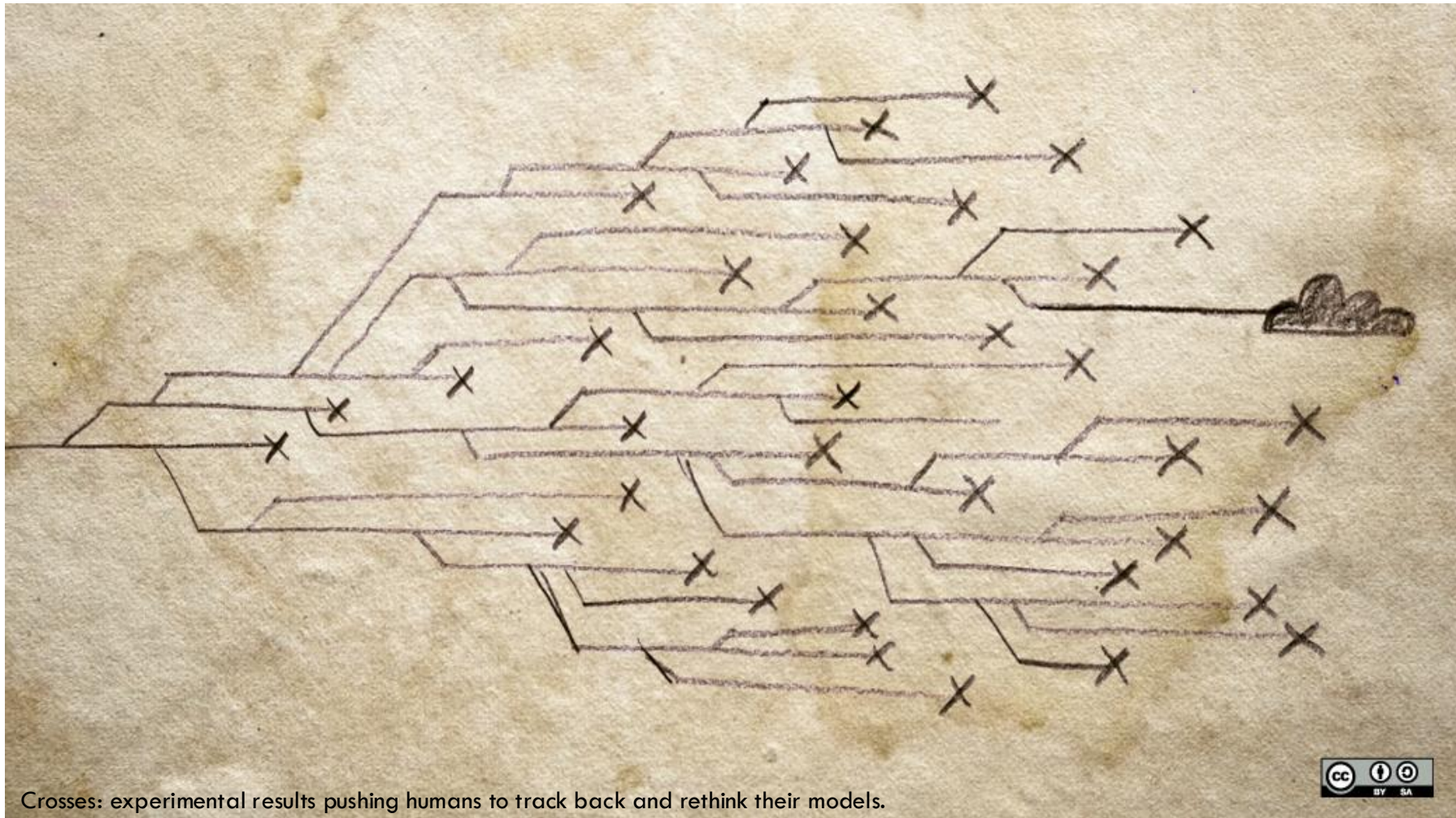

Evolutions & revolutions of the elements

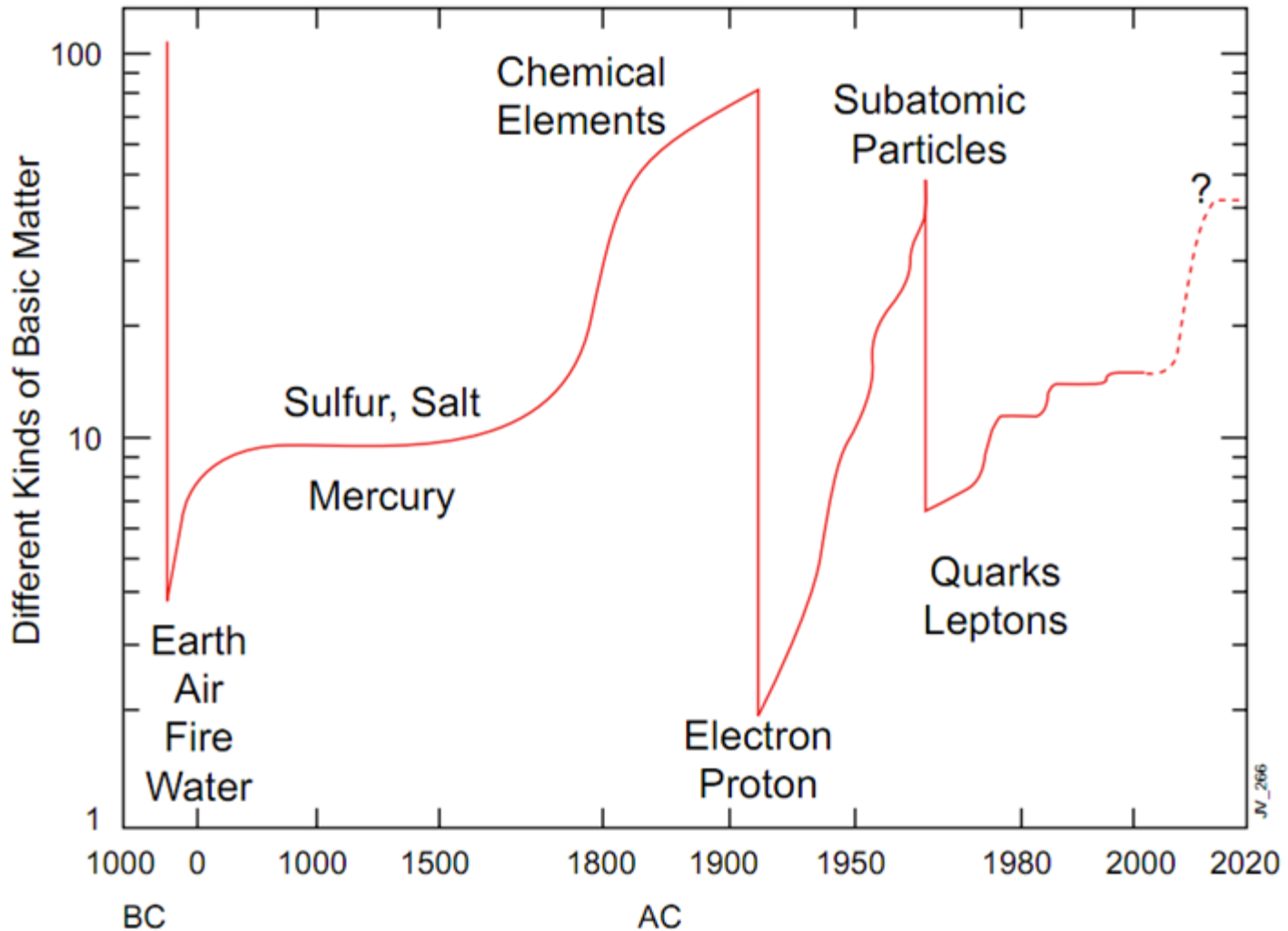

LHC – the lord of the rings



59

[<http://natronics.github.io/science-hack-day-2014/lhc-map/>]

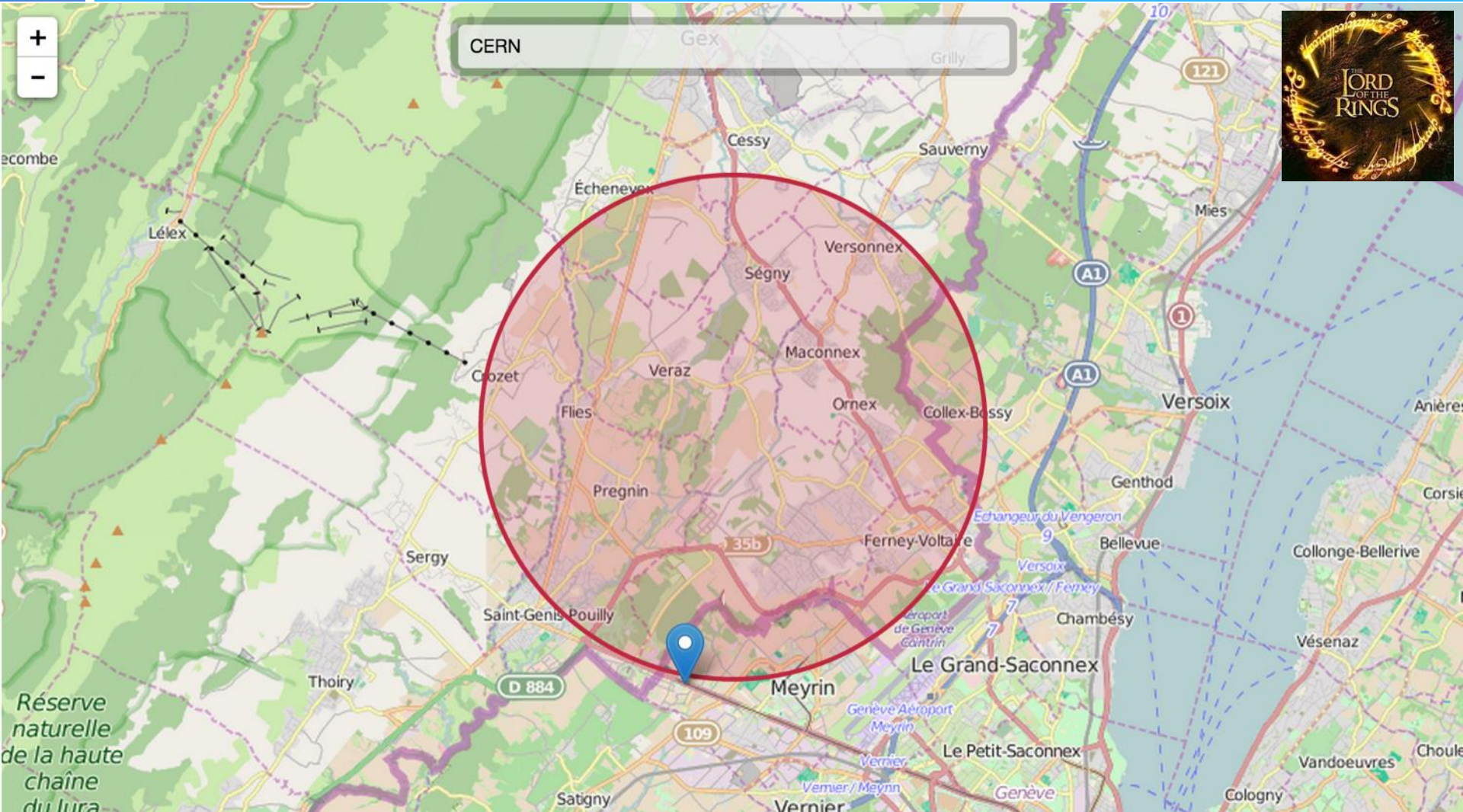

LHC – the lord of the rings



60

[<http://natronics.github.io/science-hack-day-2014/lhc-map/>]

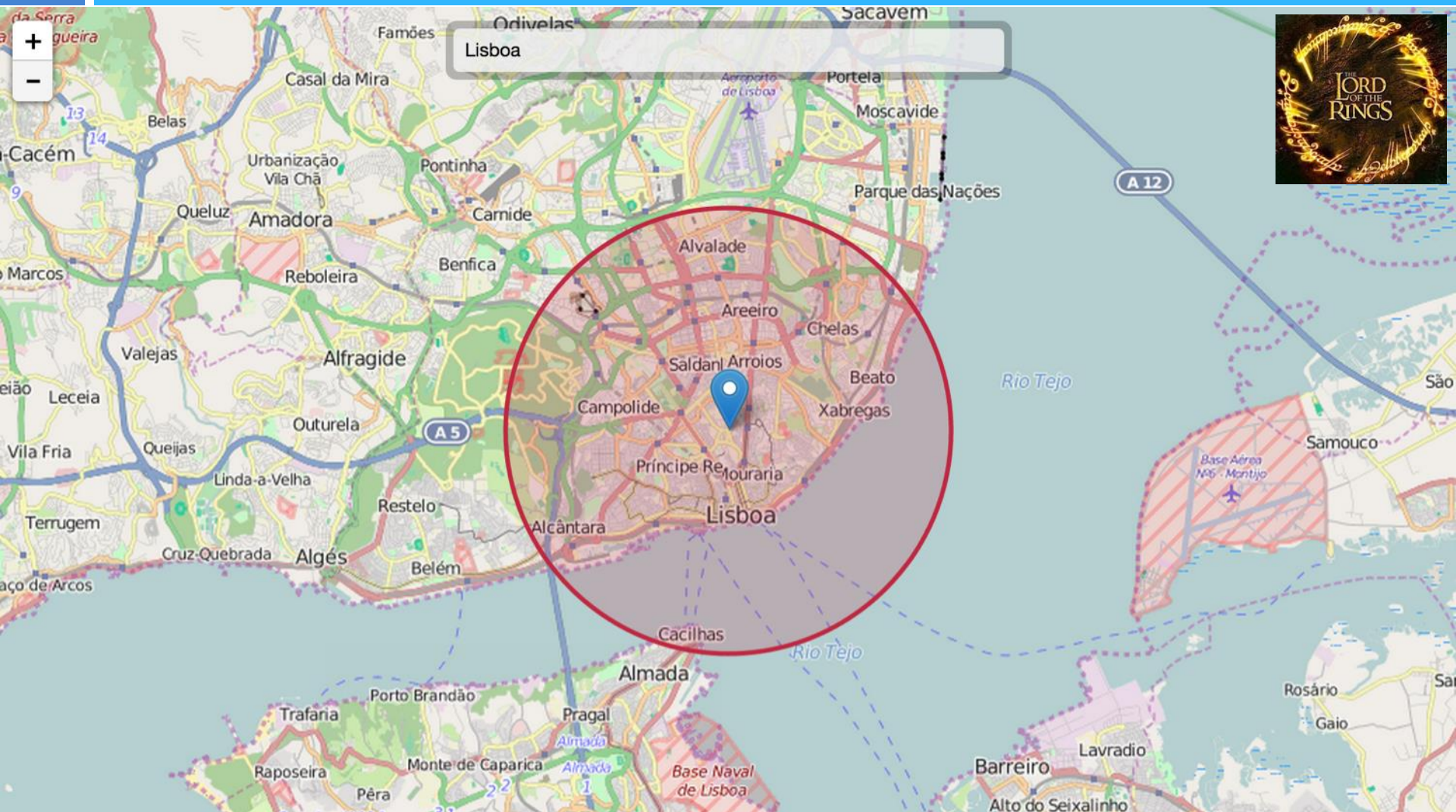

LHC – the lord of the rings



61

[<http://natronics.github.io/science-hack-day-2014/lhc-map/>]

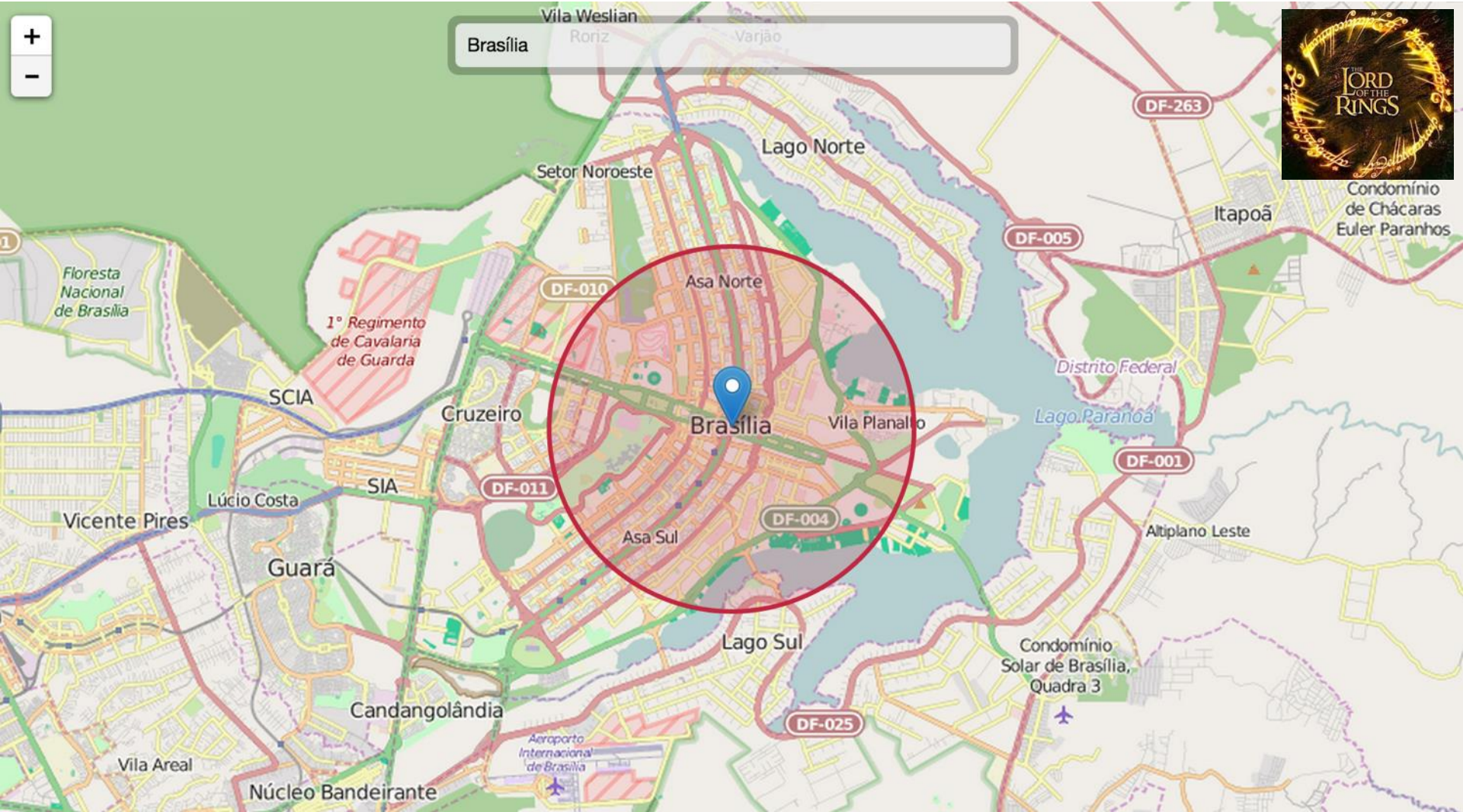

LHC – the lord of the rings



62

[<http://natronics.github.io/science-hack-day-2014/lhc-map/>]

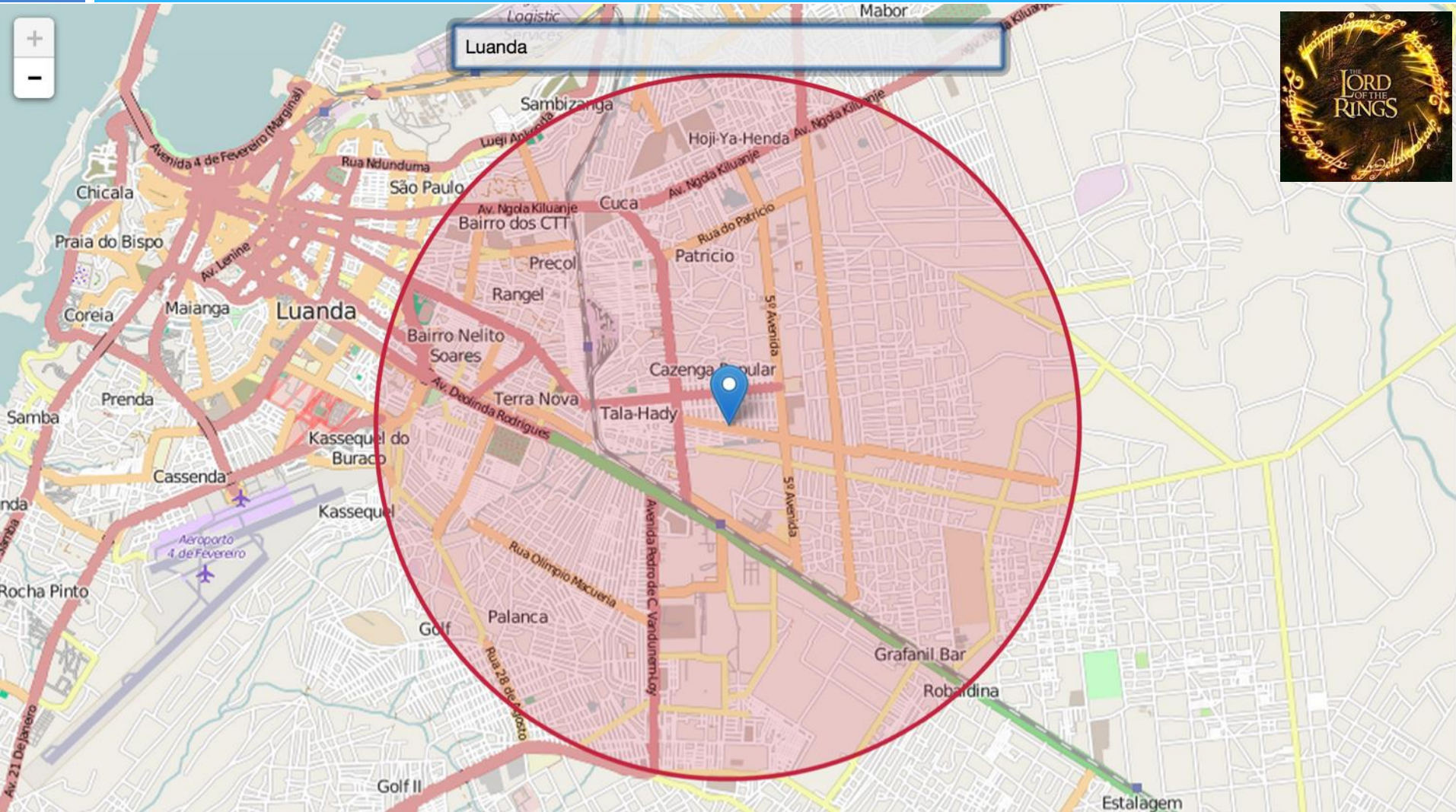

LHC – the lord of the rings



63

[<http://natronics.github.io/science-hack-day-2014/lhc-map/>]

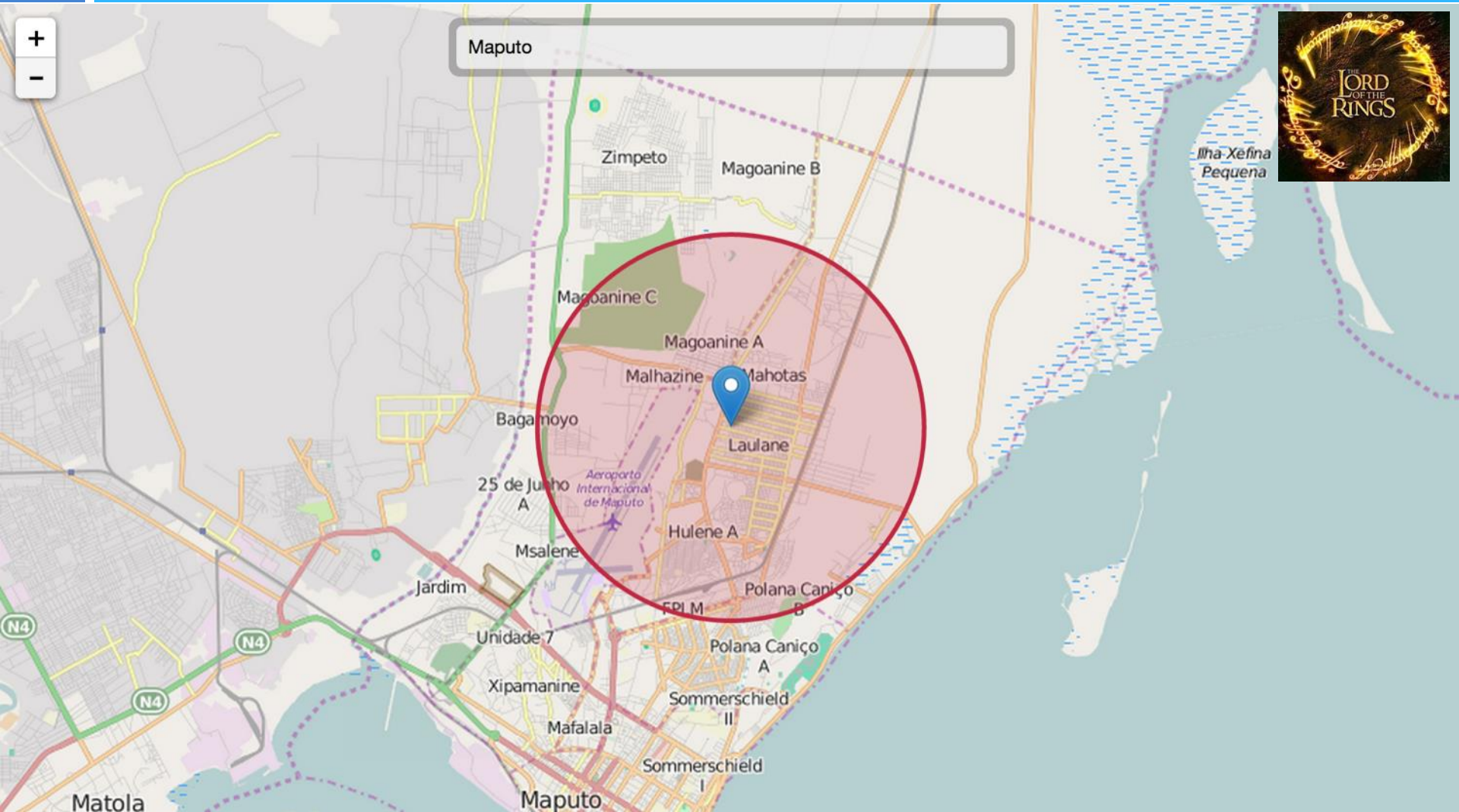

LHC – the lord of the rings



64

[<http://natronics.github.io/science-hack-day-2014/lhc-map/>]

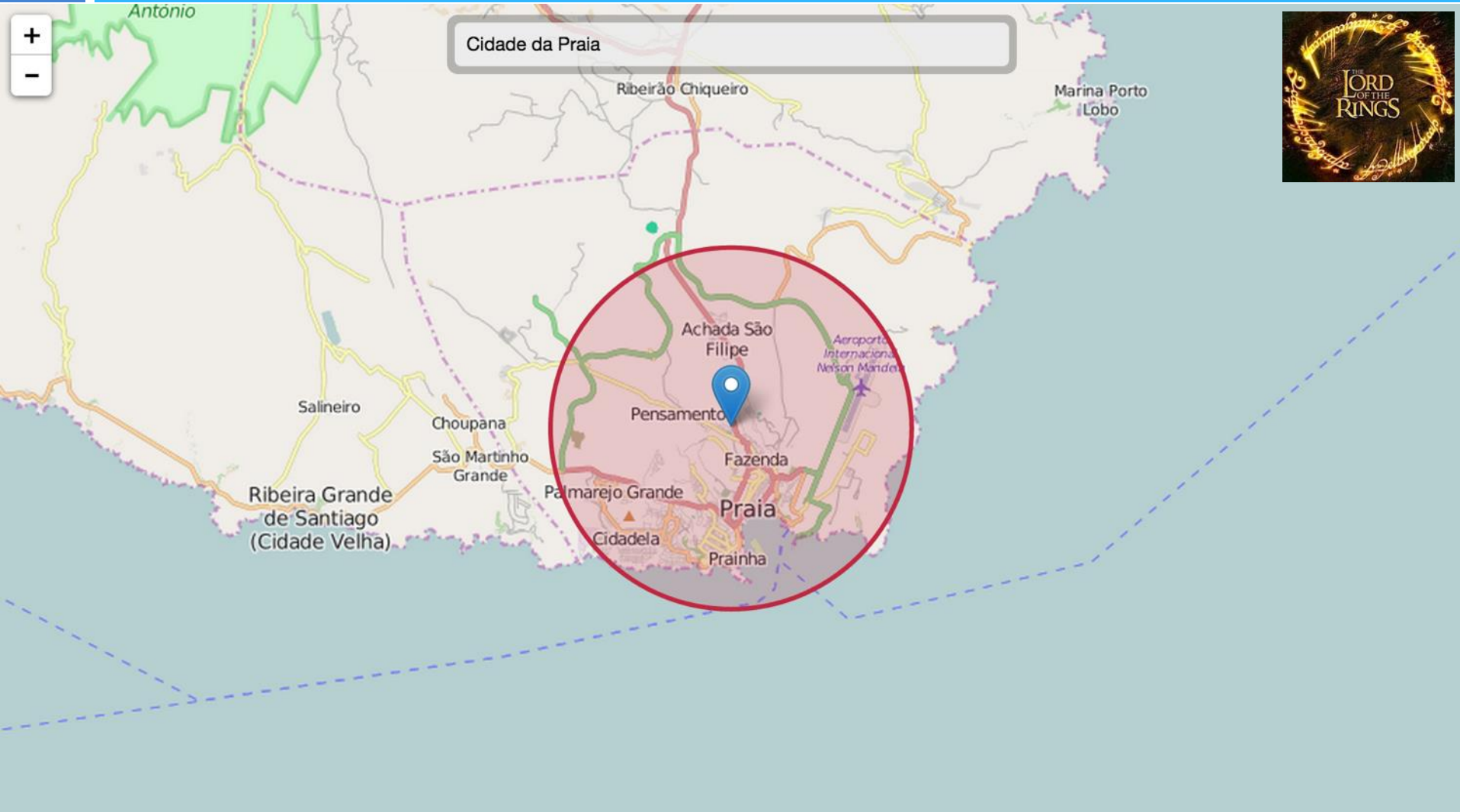

LHC – the lord of the rings



65

[<http://natronics.github.io/science-hack-day-2014/lhc-map/>]

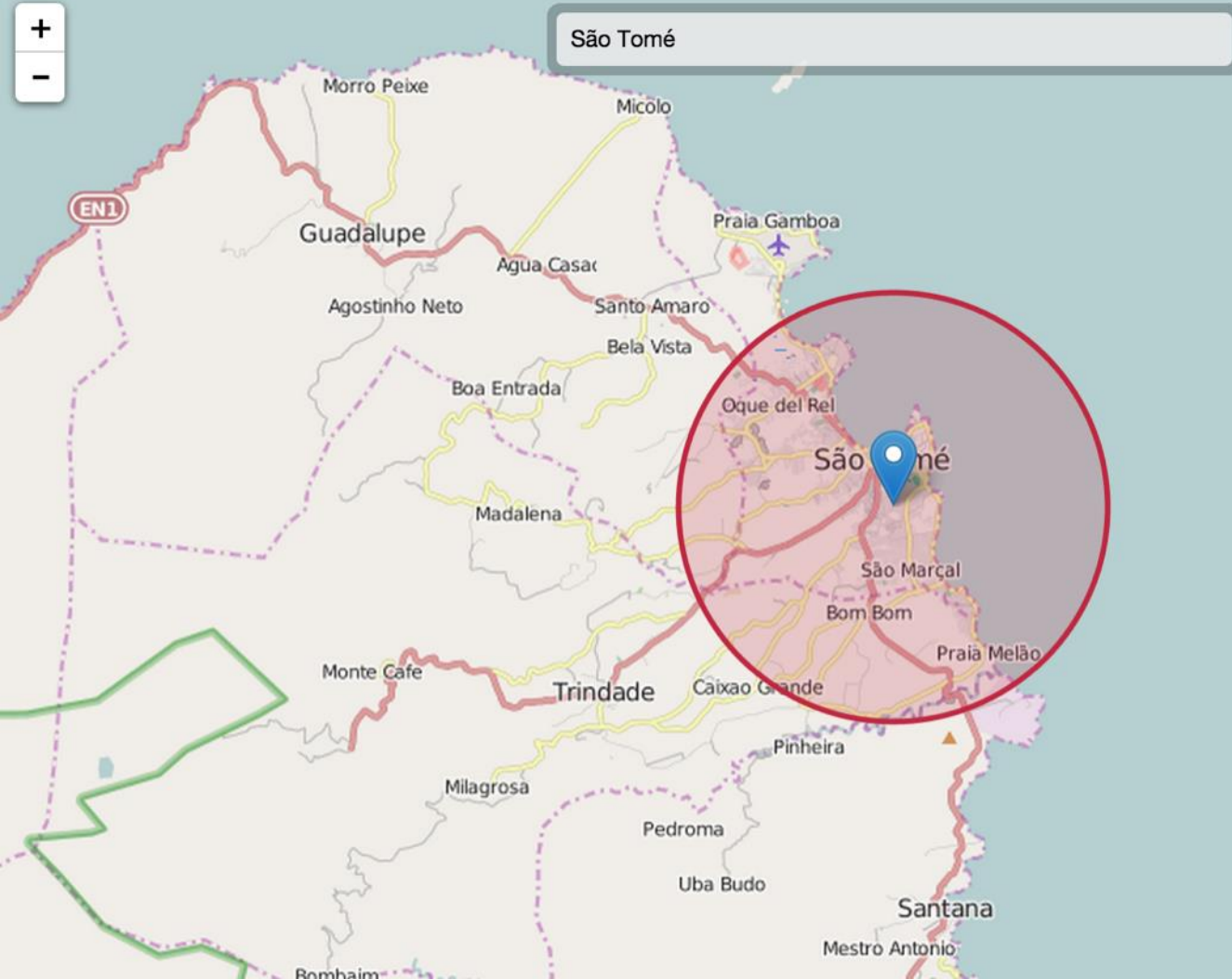

LHC – the lord of the rings



66

[<http://natronics.github.io/science-hack-day-2014/lhc-map/>]



Dili

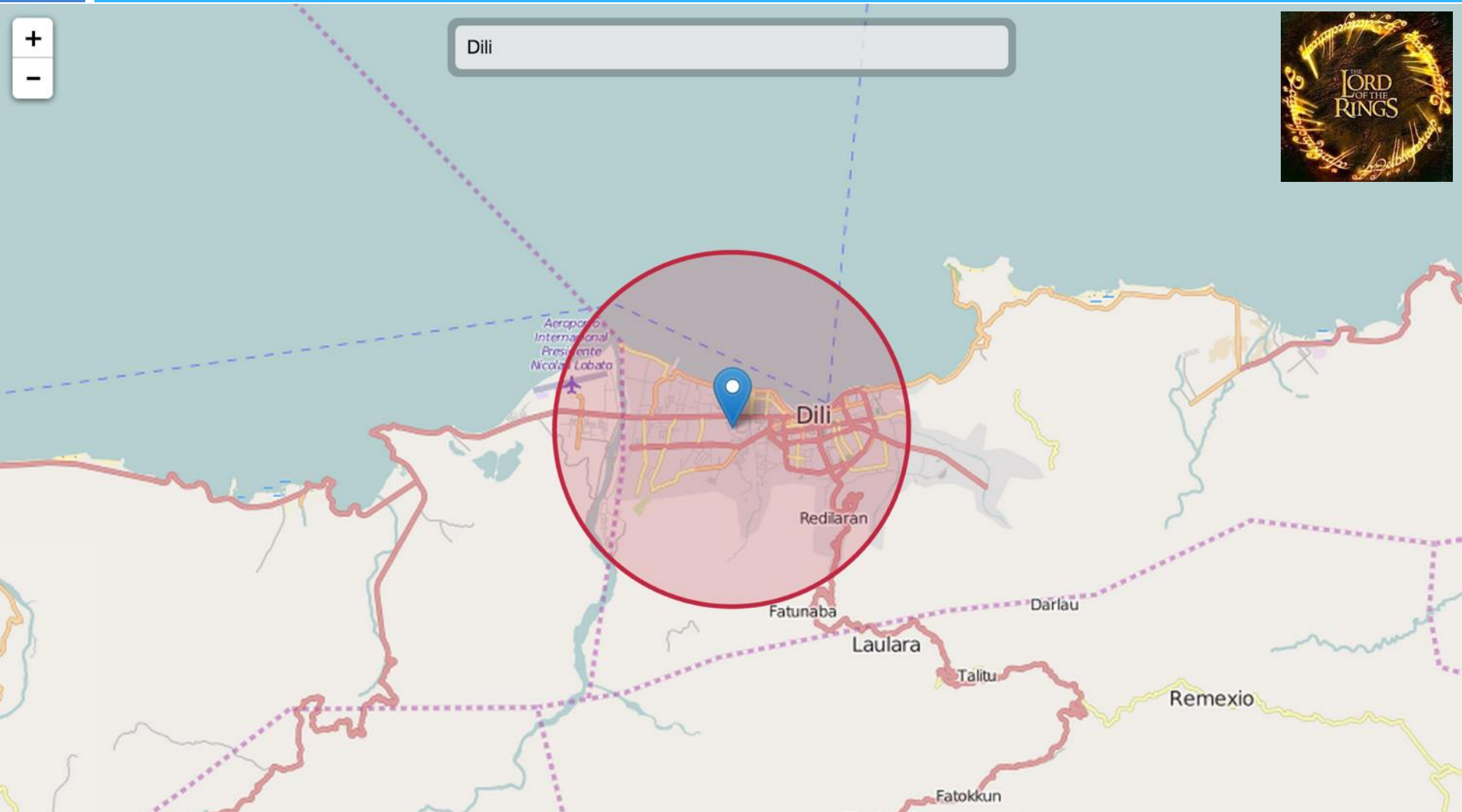

LHC – the lord of the rings



67

[<http://natronics.github.io/science-hack-day-2014/lhc-map/>]

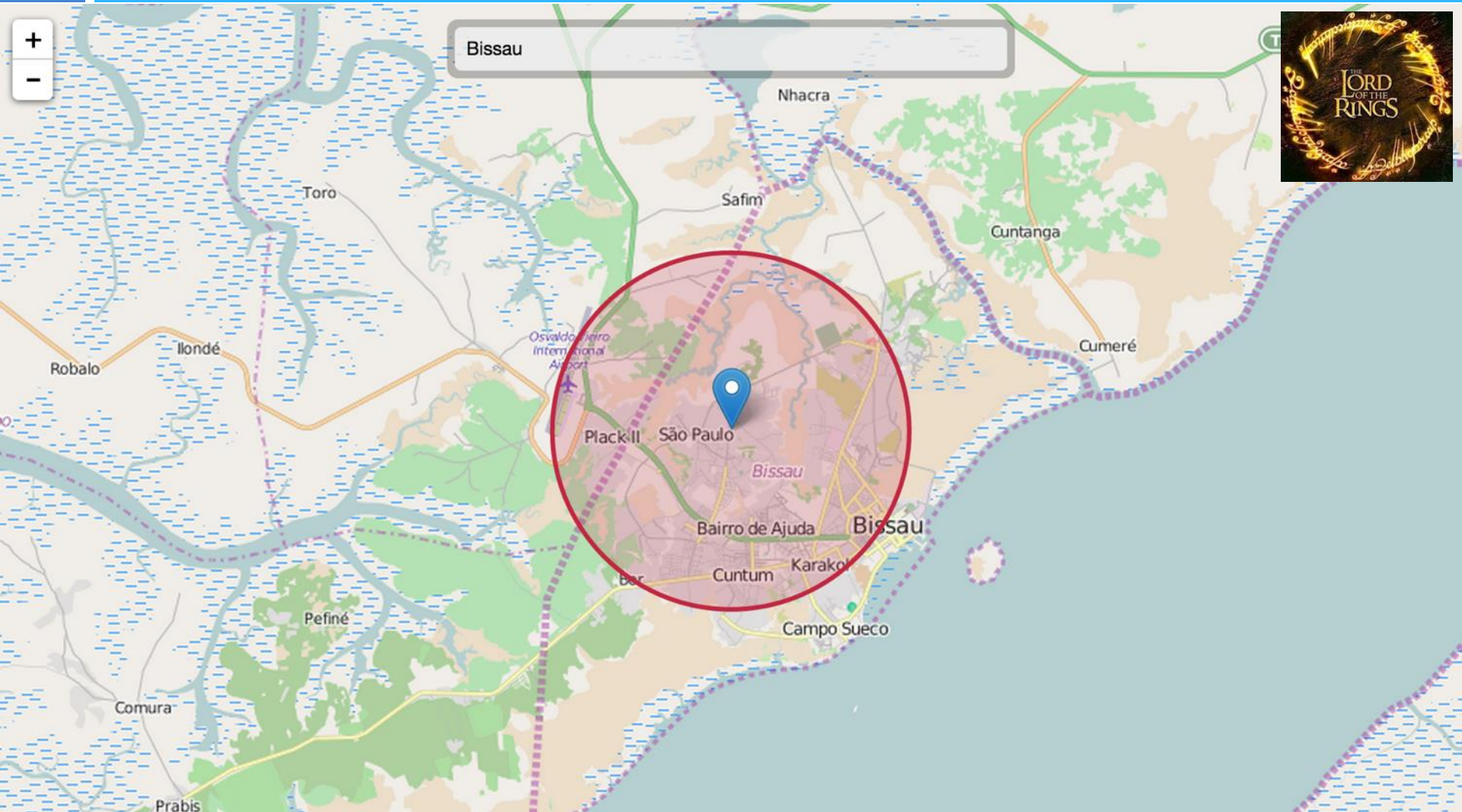

Particle detectors in CMS

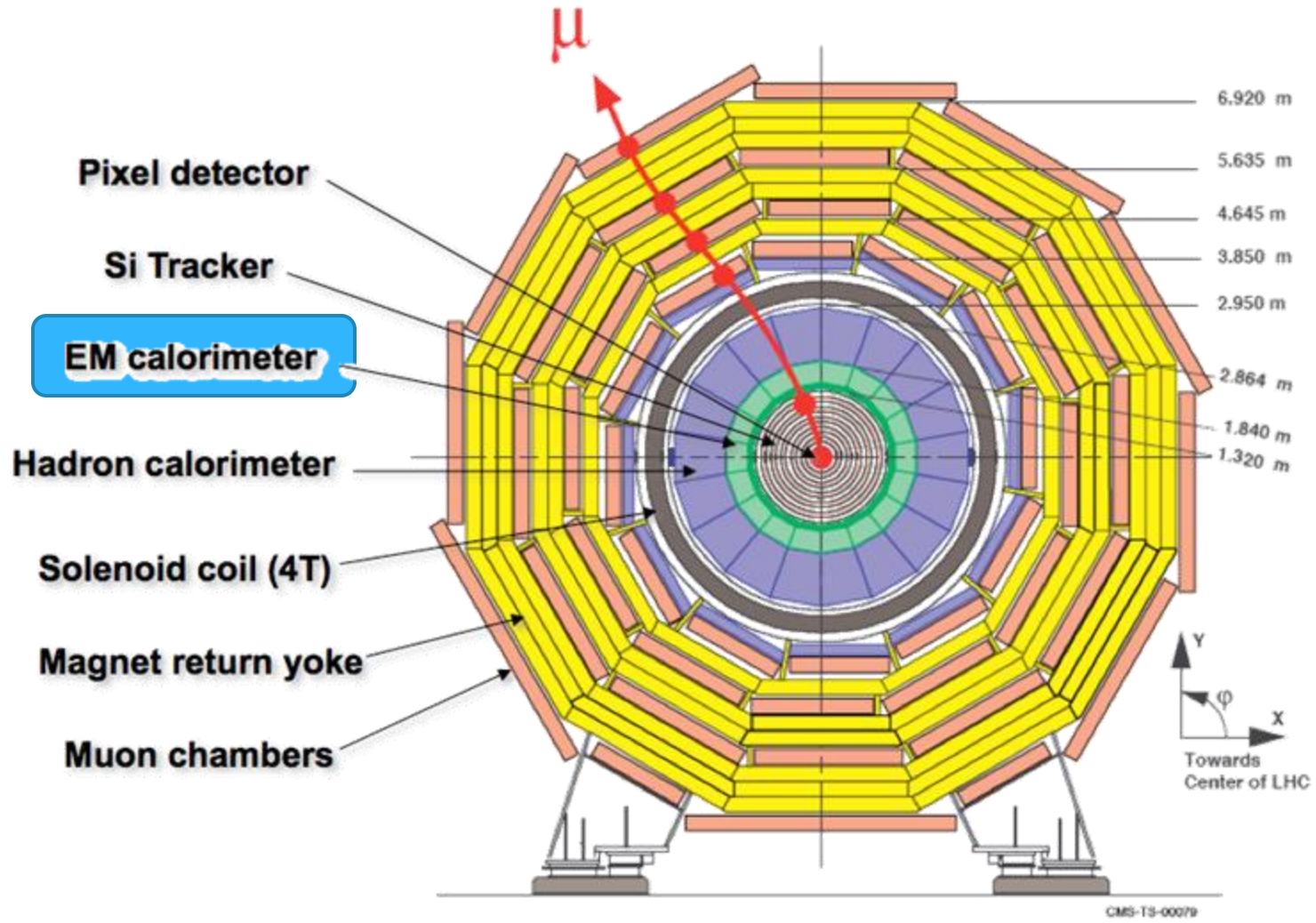

2007: ECAL barrel installed



Detecting particles in CMS

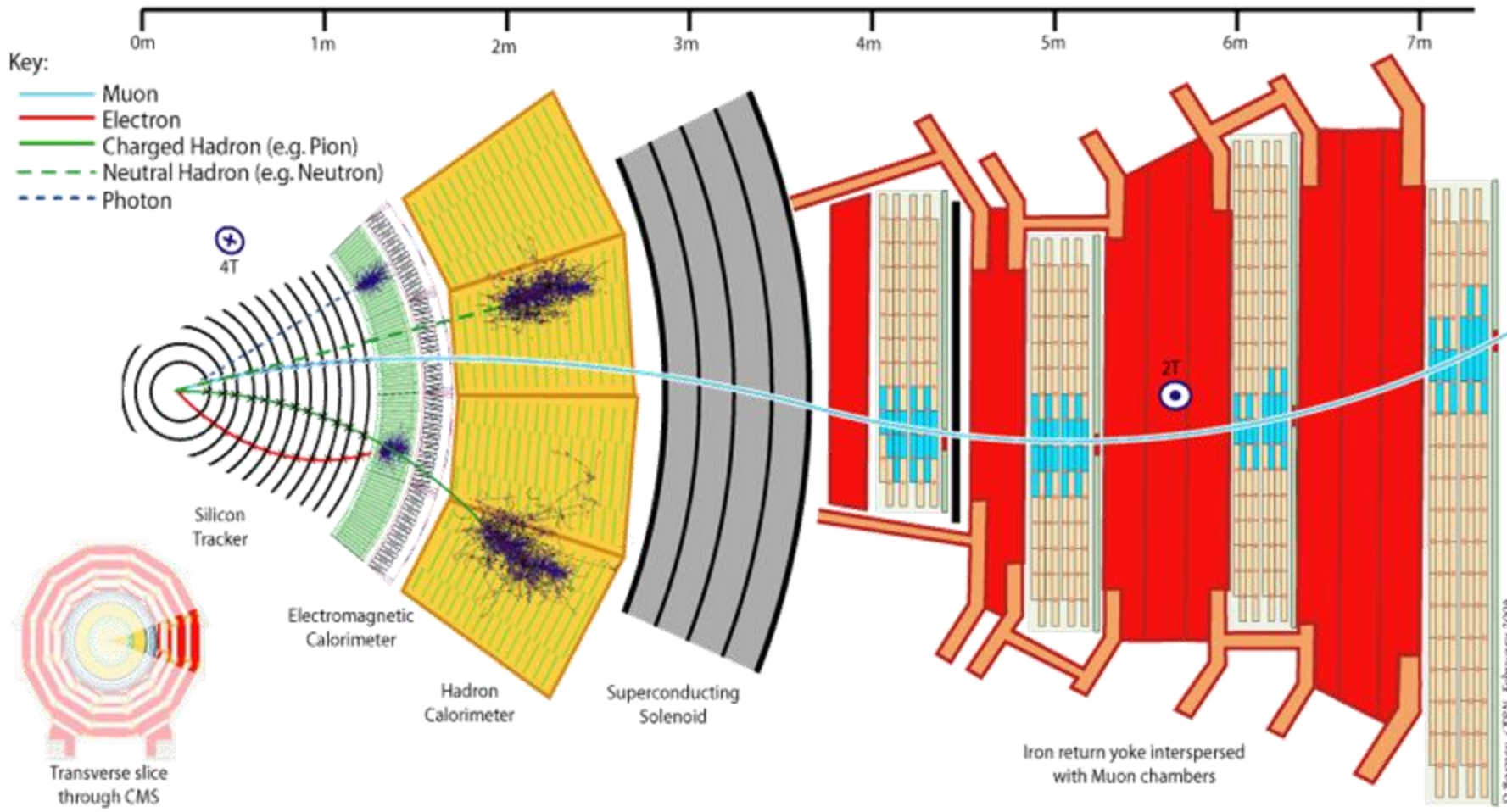

Detecting particles in CMS

71

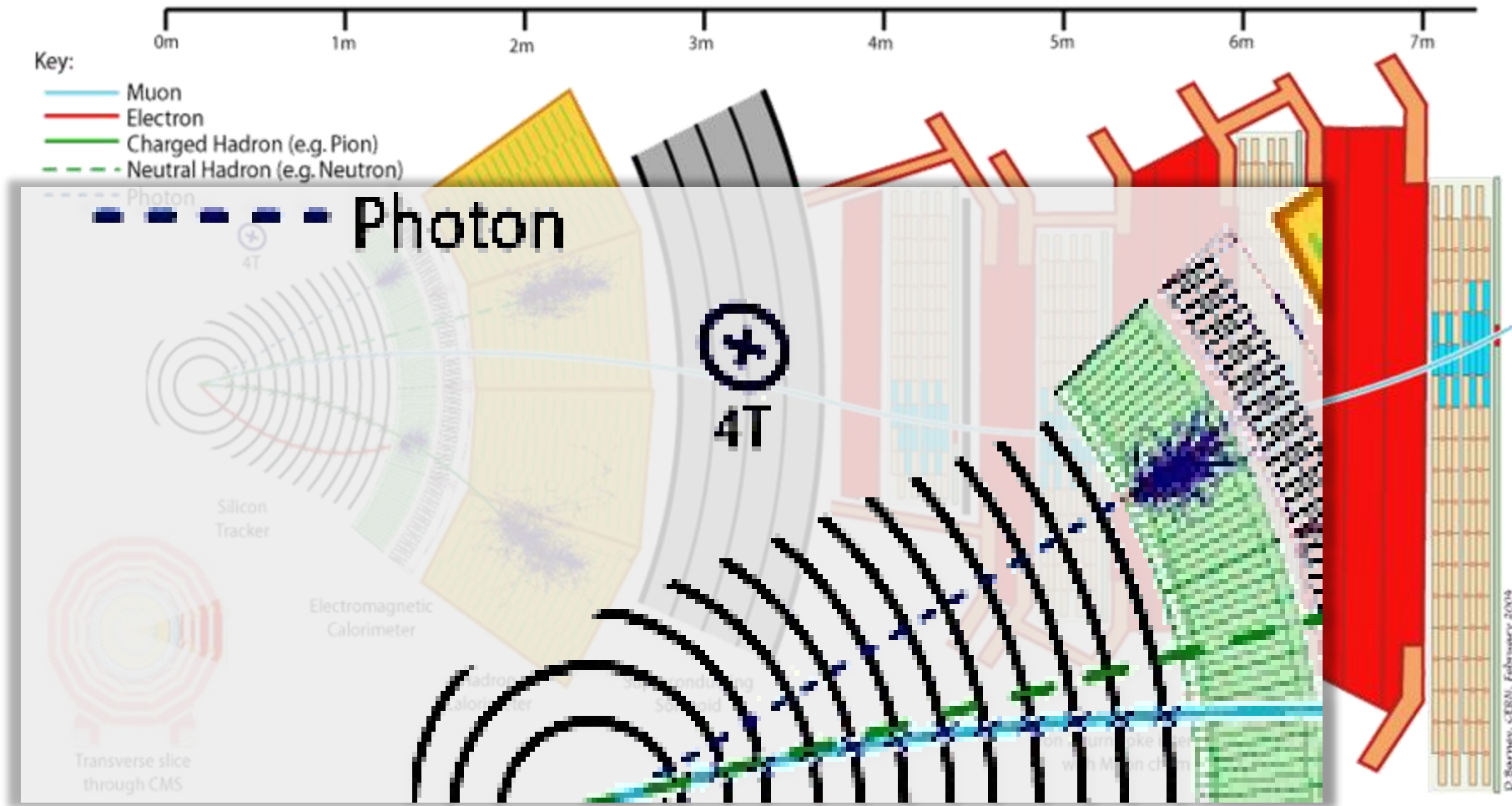



The Standard Model of Particle Physics

72

[<https://cds.cern.ch/record/2748662>]

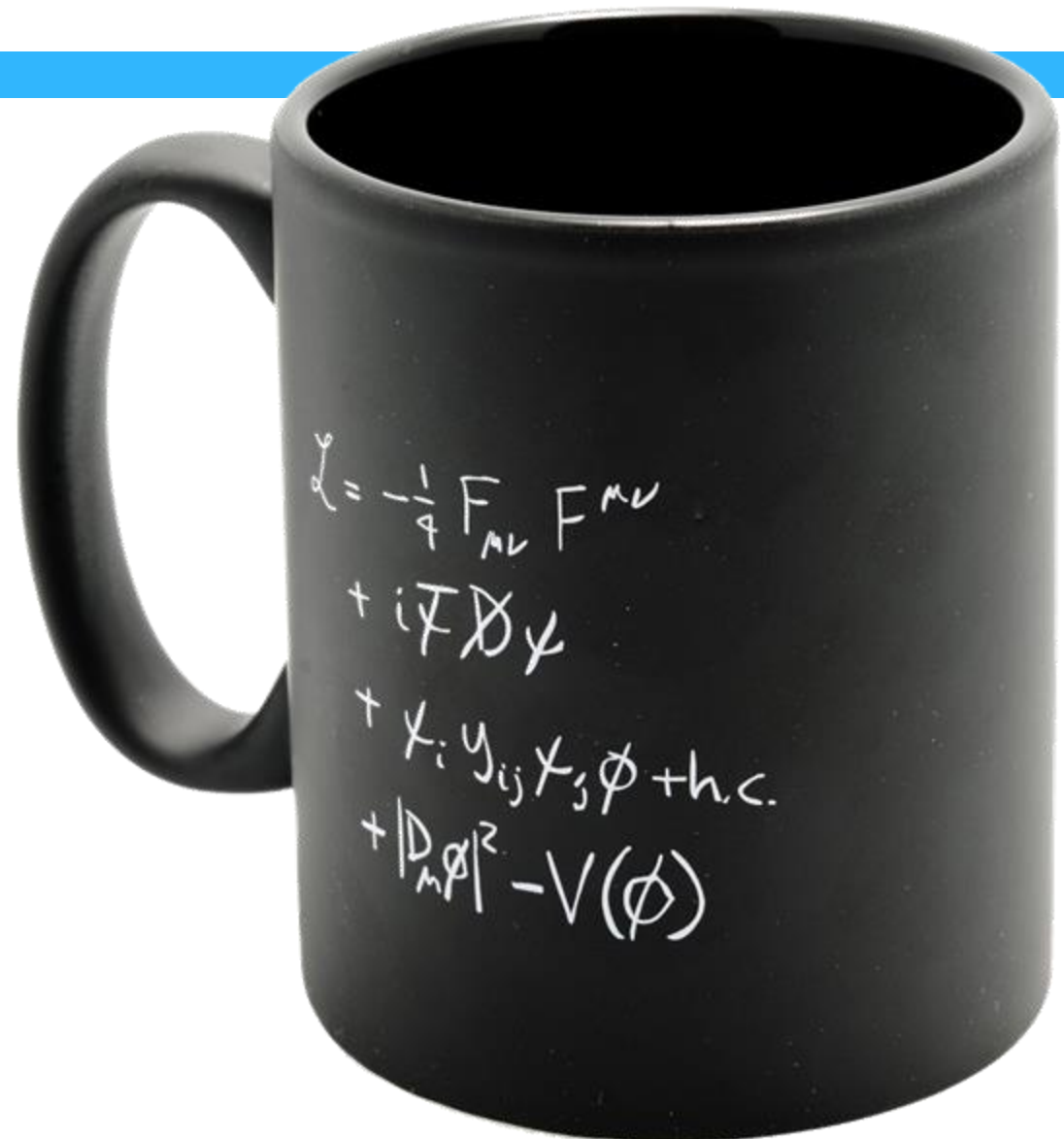

The Standard Model of Particle Physics



$$\begin{aligned}
 & -\frac{1}{2}\partial_\nu g_\mu^a \partial_\nu g_\mu^a - g_s f^{abc} \partial_\mu g_\nu^a g_\mu^b g_\nu^c - \frac{1}{4}g_s^2 f^{abc} f^{ade} g_\mu^b g_\nu^c g_\mu^d g_\nu^e + \frac{1}{2}ig_s^2 (\bar{q}_i^\sigma \gamma^\mu q_j^\sigma) g_\mu^a + \bar{G}^a \partial^2 G^a + g_s f^{abc} \partial_\mu \bar{G}^a G^b g_\mu^c - \\
 & \partial_\nu W_\mu^+ \partial_\nu W_\mu^- - M^2 W_\mu^+ W_\mu^- - \frac{1}{2}\partial_\nu Z_\mu^0 \partial_\nu Z_\mu^0 - \frac{1}{2c_w^2} M^2 Z_\mu^0 Z_\mu^0 - \frac{1}{2}\partial_\mu A_\nu \partial_\mu A_\nu - \frac{1}{2}\partial_\mu H \partial_\mu H - \frac{1}{2}m_h^2 H^2 - \partial_\mu \phi^+ \partial_\mu \phi^- - \\
 & M^2 \phi^+ \phi^- - \frac{1}{2}\partial_\mu \phi^0 \partial_\mu \phi^0 - \frac{1}{2c_w^2} M \phi^0 \phi^0 - \beta_h \left[\frac{2M^2}{g^2} + \frac{2M}{g} H + \frac{1}{2}(H^2 + \phi^0 \phi^0 + 2\phi^+ \phi^-) \right] + \frac{2M^4}{g^2} \alpha_h - igc_w [\partial_\nu Z_\mu^0 (W_\mu^+ W_\nu^- - \\
 & W_\nu^+ W_\mu^-) - Z_\nu^0 (W_\mu^+ \partial_\nu W_\mu^- - W_\mu^- \partial_\nu W_\mu^+) + Z_\mu^0 (W_\nu^+ \partial_\nu W_\mu^- - W_\nu^- \partial_\nu W_\mu^+)] - ig s_w [\partial_\nu A_\mu (W_\mu^+ W_\nu^- - W_\nu^+ W_\mu^-) - \\
 & A_\nu (W_\mu^+ \partial_\nu W_\mu^- - W_\mu^- \partial_\nu W_\mu^+) + A_\mu (W_\nu^+ \partial_\nu W_\mu^- - W_\nu^- \partial_\nu W_\mu^+)] - \frac{1}{2}g^2 W_\mu^+ W_\mu^- W_\nu^+ W_\nu^- + \frac{1}{2}g^2 W_\mu^+ W_\nu^- W_\mu^- W_\nu^+ + \\
 & g^2 c_w^2 (Z_\mu^0 W_\mu^+ Z_\nu^0 W_\nu^- - Z_\mu^0 Z_\nu^0 W_\mu^+ W_\nu^-) + g^2 s_w^2 (A_\mu W_\mu^+ A_\nu W_\nu^- - A_\mu A_\nu W_\mu^+ W_\nu^-) + g^2 s_w c_w [A_\mu Z_\nu^0 (W_\mu^+ W_\nu^- - \\
 & W_\nu^+ W_\mu^-) - 2A_\mu Z_\mu^0 W_\nu^+ W_\nu^-] - g\alpha [H^3 + H\phi^0 \phi^0 + 2H\phi^+ \phi^-] - \frac{1}{8}g^2 \alpha_h [H^4 + (\phi^0)^4 + 4(\phi^+ \phi^-)^2 + 4(\phi^0)^2 \phi^+ \phi^- + \\
 & 4H^2 \phi^+ \phi^- + 2(\phi^0)^2 H^2] - g M W_\mu^+ W_\mu^- H - \frac{1}{2}g \frac{M}{c_w^2} Z_\mu^0 Z_\mu^0 H - \frac{1}{2}ig [W_\mu^+ (\phi^0 \partial_\mu \phi^- - \phi^- \partial_\mu \phi^0) - W_\mu^- (\phi^0 \partial_\mu \phi^+ - \phi^+ \partial_\mu \phi^0)] + \\
 & \frac{1}{2}g [W_\mu^+ (H \partial_\mu \phi^- - \phi^- \partial_\mu H) - W_\mu^- (H \partial_\mu \phi^+ - \phi^+ \partial_\mu H)] + \frac{1}{2}g \frac{1}{c_w} (Z_\mu^0 (H \partial_\mu \phi^0 - \phi^0 \partial_\mu H) - ig \frac{s_w^2}{c_w} M Z_\mu^0 (W_\mu^+ \phi^- - \\
 & W_\mu^- \phi^+) + ig s_w M A_\mu (W_\mu^+ \phi^- - W_\mu^- \phi^+) - ig \frac{1-2c_w^2}{2c_w} Z_\mu^0 (\phi^+ \partial_\mu \phi^- - \phi^- \partial_\mu \phi^+) + ig s_w A_\mu (\phi^+ \partial_\mu \phi^- - \phi^- \partial_\mu \phi^+) - \\
 & \frac{1}{4}g^2 W_\mu^+ W_\mu^- [H^2 + (\phi^0)^2 + 2\phi^+ \phi^-] - \frac{1}{4}g^2 \frac{1}{c_w^2} Z_\mu^0 Z_\mu^0 [H^2 + (\phi^0)^2 + 2(2s_w^2 - 1)^2 \phi^+ \phi^-] - \frac{1}{2}g^2 \frac{s_w^2}{c_w} Z_\mu^0 \phi^0 (W_\mu^+ \phi^- + \\
 & W_\mu^- \phi^+) - \frac{1}{2}ig^2 \frac{s_w^2}{c_w} Z_\mu^0 H (W_\mu^+ \phi^- - W_\mu^- \phi^+) + \frac{1}{2}g^2 s_w A_\mu \phi^0 (W_\mu^+ \phi^- + W_\mu^- \phi^+) + \frac{1}{2}ig^2 s_w A_\mu H (W_\mu^+ \phi^- - W_\mu^- \phi^+) - \\
 & g^2 \frac{s_w}{c_w} (2c_w^2 - 1) Z_\mu^0 A_\mu \phi^+ \phi^- - g^1 s_w^2 A_\mu A_\mu \phi^+ \phi^- - \bar{e}^\lambda (\gamma \partial + m_e^\lambda) e^\lambda - \bar{\nu}^\lambda \gamma \partial \nu^\lambda - \bar{u}_j^\lambda (\gamma \partial + m_u^\lambda) u_j^\lambda - \bar{d}_j^\lambda (\gamma \partial + m_d^\lambda) d_j^\lambda + \\
 & ig s_w A_\mu [-(\bar{e}^\lambda \gamma^\mu e^\lambda) + \frac{2}{3}(\bar{u}_j^\lambda \gamma^\mu u_j^\lambda) - \frac{1}{3}(\bar{d}_j^\lambda \gamma^\mu d_j^\lambda)] + \frac{ig}{4c_w} Z_\mu^0 [(\bar{\nu}^\lambda \gamma^\mu (1 + \gamma^5) \nu^\lambda) + (\bar{e}^\lambda \gamma^\mu (4s_w^2 - 1 - \gamma^5) e^\lambda) + (\bar{u}_j^\lambda \gamma^\mu (\frac{4}{3}s_w^2 - \\
 & 1 - \gamma^5) u_j^\lambda) + (\bar{d}_j^\lambda \gamma^\mu (1 - \frac{8}{3}s_w^2 - \gamma^5) d_j^\lambda)] + \frac{ig}{2\sqrt{2}} W_\mu^+ [(\bar{\nu}^\lambda \gamma^\mu (1 + \gamma^5) e^\lambda) + (\bar{u}_j^\lambda \gamma^\mu (1 + \gamma^5) C_{\lambda\kappa} d_j^\kappa)] + \frac{ig}{2\sqrt{2}} W_\mu^- [(\bar{e}^\lambda \gamma^\mu (1 + \\
 & \gamma^5) \nu^\lambda) + (\bar{d}_j^\kappa C_{\lambda\kappa}^\dagger \gamma^\mu (1 + \gamma^5) u_j^\lambda)] + \frac{ig}{2\sqrt{2}} \frac{m_e^\lambda}{M} [-\phi^+ (\bar{\nu}^\lambda (1 - \gamma^5) e^\lambda) + \phi^- (\bar{e}^\lambda (1 + \gamma^5) \nu^\lambda)] - \frac{g}{2} \frac{m_e^\lambda}{M} [H (\bar{e}^\lambda e^\lambda) + \\
 & i\phi^0 (\bar{e}^\lambda \gamma^5 e^\lambda)] + \frac{ig}{2M\sqrt{2}} \phi^+ [-m_d^\kappa (\bar{u}_j^\lambda C_{\lambda\kappa} (1 - \gamma^5) d_j^\kappa) + m_u^\lambda (\bar{u}_j^\lambda C_{\lambda\kappa} (1 + \gamma^5) d_j^\kappa) + \frac{ig}{2M\sqrt{2}} \phi^- [m_d^\lambda (\bar{d}_j^\lambda C_{\lambda\kappa}^\dagger (1 + \gamma^5) u_j^\kappa) - \\
 & m_u^\kappa (\bar{d}_j^\lambda C_{\lambda\kappa}^\dagger (1 - \gamma^5) u_j^\kappa) - \frac{g}{2} \frac{m_u^\lambda}{M} H (\bar{u}_j^\lambda u_j^\lambda) - \frac{g}{2} \frac{m_d^\lambda}{M} H (\bar{d}_j^\lambda d_j^\lambda) + \frac{ig}{2} \frac{m_u^\lambda}{M} \phi^0 (\bar{u}_j^\lambda \gamma^5 u_j^\lambda) - \frac{ig}{2} \frac{m_d^\lambda}{M} \phi^0 (\bar{d}_j^\lambda \gamma^5 d_j^\lambda) + \bar{X}^+ (\partial^2 - \\
 & M^2) X^+ + \bar{X}^- (\partial^2 - M^2) X^- + \bar{X}^0 (\partial^2 - \frac{M^2}{c_w^2}) X^0 + \bar{Y} \partial^2 Y + igc_w W_\mu^+ (\partial_\mu \bar{X}^0 X^- - \partial_\mu \bar{X}^+ X^0) + ig s_w W_\mu^+ (\partial_\mu \bar{Y} X^- - \\
 & \partial_\mu \bar{X}^+ Y) + igc_w W_\mu^- (\partial_\mu \bar{X}^- X^0 - \partial_\mu \bar{X}^0 X^+) + ig s_w W_\mu^- (\partial_\mu \bar{X}^- Y - \partial_\mu \bar{Y} X^+) + igc_w Z_\mu^0 (\partial_\mu \bar{X}^+ X^+ - \partial_\mu \bar{X}^- X^-) + \\
 & ig s_w A_\mu (\partial_\mu \bar{X}^+ X^+ - \partial_\mu \bar{X}^- X^-) - \frac{1}{2}g M [\bar{X}^+ X^+ H + \bar{X}^- X^- H + \frac{1}{c_w^2} \bar{X}^0 X^0 H] + \frac{1-2c_w^2}{2c_w} ig M [\bar{X}^+ X^0 \phi^+ - \\
 & \bar{X}^- X^0 \phi^-] + \frac{1}{2c_w} ig M [\bar{X}^0 X^- \phi^+ - \bar{X}^0 X^+ \phi^-] + ig M s_w [\bar{X}^0 X^- \phi^+ - \bar{X}^0 X^+ \phi^-] + \frac{1}{2}ig M [\bar{X}^+ X^+ \phi^0 - \bar{X}^- X^- \phi^0]
 \end{aligned}$$

The Standard Model of Particle Physics



$$\begin{aligned}
 & -\frac{1}{2}\partial_\nu g_\mu^a \partial_\nu g_\mu^a - g_s f^{abc} \partial_\mu g_\nu^a g_\mu^b g_\nu^c - \frac{1}{4}g_s^2 f^{abc} f^{ade} g_\mu^b g_\nu^c g_\mu^d g_\nu^e + \frac{1}{2}ig_s^2 (\bar{q}_i^\sigma \gamma^\mu q_j^\sigma) g_\mu^a + \bar{G}^a \partial^2 G^a + g_s f^{abc} \partial_\mu \bar{G}^a G^b g_\mu^c - \\
 & \partial_\nu W_\mu^+ \partial_\nu W_\mu^- - M^2 W_\mu^+ W_\mu^- - \frac{1}{2}\partial_\nu Z_\mu^0 \partial_\nu Z_\mu^0 - \frac{1}{2c_w^2} M^2 Z_\mu^0 Z_\mu^0 - \frac{1}{2}\partial_\mu A_\nu \partial_\mu A_\nu - \frac{1}{2}\partial_\mu H \partial_\mu H - \frac{1}{2}m_h^2 H^2 - \partial_\mu \phi^+ \partial_\mu \phi^- - \\
 & M^2 \phi^+ \phi^- - \frac{1}{2}\partial_\mu \phi^0 \partial_\mu \phi^0 - \frac{1}{2c_w^2} M \phi^0 \phi^0 - \beta_h [\frac{2M^2}{g^2} + \frac{2M}{g} H + \frac{1}{2}(H^2 + \phi^0 \phi^0 + 2\phi^+ \phi^-)] + \frac{2M^4}{g^2} \alpha_h - igc_w [\partial_\nu Z_\mu^0 (W_\mu^+ W_\nu^- - \\
 & W_\nu^+ W_\mu^-) - Z_\nu^0 (W_\mu^+ \partial_\nu W_\mu^- - W_\mu^- \partial_\nu W_\mu^+) + Z_\mu^0 (W_\nu^+ \partial_\nu W_\mu^- - W_\nu^- \partial_\nu W_\mu^+)] - ig s_w [\partial_\nu A_\mu (W_\mu^+ W_\nu^- - W_\nu^+ W_\mu^-) - \\
 & A_\nu (W_\mu^+ \partial_\nu W_\mu^- - W_\mu^- \partial_\nu W_\mu^+) + A_\mu (W_\nu^+ \partial_\nu W_\mu^- - W_\nu^- \partial_\nu W_\mu^+)] - \frac{1}{2}g^2 W_\mu^+ W_\mu^- W_\nu^+ W_\nu^- + \frac{1}{2}g^2 W_\mu^+ W_\nu^- W_\mu^- W_\nu^+ + \\
 & g^2 c_w^2 (Z_\mu^0 W_\mu^+ Z_\nu^0 W_\nu^- - Z_\mu^0 Z_\nu^0 W_\mu^+ W_\nu^-) + g^2 s_w^2 (A_\mu W_\mu^+ A_\nu W_\nu^- - A_\mu A_\nu W_\mu^+ W_\nu^-) + g^2 s_w c_w [A_\mu Z_\nu^0 (W_\mu^+ W_\nu^- - \\
 & W_\nu^+ W_\mu^-) - 2A_\mu Z_\mu^0 W_\nu^+ W_\nu^-] - g\alpha [H^3 + H\phi^0 \phi^0 + 2H\phi^+ \phi^-] - \frac{1}{8}g^2 \alpha_h [H^4 + (\phi^0)^4 + 4(\phi^+ \phi^-)^2 + 4(\phi^0)^2 \phi^+ \phi^- + \\
 & 4H^2 \phi^+ \phi^- + 2(\phi^0)^2 H^2] - gM [W_\mu^+ W_\mu^- H - \frac{1}{2}g \frac{M}{c_w^2} Z_\mu^0 Z_\mu^0 H] - \frac{1}{2}ig [W_\mu^+ (\phi^0 \partial_\mu \phi^- - \phi^- \partial_\mu \phi^0) - W_\mu^- (\phi^0 \partial_\mu \phi^+ - \phi^+ \partial_\mu \phi^0)] + \\
 & \frac{1}{2}g [W_\mu^+ (H \partial_\mu \phi^- - \phi^- \partial_\mu H) - W_\mu^- (H \partial_\mu \phi^+ - \phi^+ \partial_\mu H)] + \frac{1}{2}g \frac{1}{c_w} (Z_\mu^0 (H \partial_\mu \phi^0 - \phi^0 \partial_\mu H) - ig \frac{s_w^2}{c_w} M Z_\mu^0 (W_\mu^+ \phi^- - \\
 & W_\mu^- \phi^+) + ig s_w M A_\mu (W_\mu^+ \phi^- - W_\mu^- \phi^+) - ig \frac{1-2c_w^2}{2c_w} Z_\mu^0 (\phi^+ \partial_\mu \phi^- - \phi^- \partial_\mu \phi^+) + ig s_w A_\mu (\phi^+ \partial_\mu \phi^- - \phi^- \partial_\mu \phi^+) - \\
 & \frac{1}{4}g^2 W_\mu^+ W_\mu^- [H^2 + (\phi^0)^2 + 2\phi^+ \phi^-] - \frac{1}{4}g^2 \frac{1}{c_w^2} Z_\mu^0 Z_\mu^0 [H^2 + (\phi^0)^2 + 2(2s_w^2 - 1)^2 \phi^+ \phi^-] - \frac{1}{2}g^2 \frac{s_w^2}{c_w} Z_\mu^0 \phi^0 (W_\mu^+ \phi^- + \\
 & W_\mu^- \phi^+) - \frac{1}{2}ig^2 \frac{s_w^2}{c_w} Z_\mu^0 H (W_\mu^+ \phi^- - W_\mu^- \phi^+) + \frac{1}{2}g^2 s_w A_\mu \phi^0 (W_\mu^+ \phi^- + W_\mu^- \phi^+) + \frac{1}{2}ig^2 s_w A_\mu H (W_\mu^+ \phi^- - W_\mu^- \phi^+) - \\
 & g^2 \frac{s_w}{c_w} (2c_w^2 - 1) Z_\mu^0 A_\mu \phi^+ \phi^- - g^1 s_w^2 A_\mu A_\mu \phi^+ \phi^- - \bar{e}^\lambda (\gamma \partial + m_e^\lambda) e^\lambda - \bar{\nu}^\lambda \gamma \partial \nu^\lambda - \bar{u}_j^\lambda (\gamma \partial + m_u^\lambda) u_j^\lambda - \bar{d}_j^\lambda (\gamma \partial + m_d^\lambda) d_j^\lambda + \\
 & ig s_w A_\mu [-(\bar{e}^\lambda \gamma^\mu e^\lambda) + \frac{2}{3}(\bar{u}_j^\lambda \gamma^\mu u_j^\lambda) - \frac{1}{3}(\bar{d}_j^\lambda \gamma^\mu d_j^\lambda)] + \frac{ig}{4c_w} Z_\mu^0 [(\bar{\nu}^\lambda \gamma^\mu (1 + \gamma^5) \nu^\lambda) + (\bar{e}^\lambda \gamma^\mu (4s_w^2 - 1 - \gamma^5) e^\lambda) + (\bar{u}_j^\lambda \gamma^\mu (\frac{4}{3}s_w^2 - \\
 & 1 - \gamma^5) u_j^\lambda) + (\bar{d}_j^\lambda \gamma^\mu (1 - \frac{8}{3}s_w^2 - \gamma^5) d_j^\lambda)] + \frac{ig}{2\sqrt{2}} W_\mu^+ [(\bar{\nu}^\lambda \gamma^\mu (1 + \gamma^5) e^\lambda) + (\bar{u}_j^\lambda \gamma^\mu (1 + \gamma^5) C_{\lambda\kappa} d_j^\kappa)] + \frac{ig}{2\sqrt{2}} W_\mu^- [(\bar{e}^\lambda \gamma^\mu (1 + \\
 & \gamma^5) \nu^\lambda) + (\bar{d}_j^\kappa C_{\lambda\kappa}^\dagger \gamma^\mu (1 + \gamma^5) u_j^\lambda)] + \frac{ig}{2\sqrt{2}} \frac{m_\lambda^2}{M} [-\phi^+ (\bar{\nu}^\lambda (1 - \gamma^5) e^\lambda) + \phi^- (\bar{e}^\lambda (1 + \gamma^5) \nu^\lambda)] - \frac{g}{2} \frac{m_\lambda^2}{M} [H (\bar{e}^\lambda e^\lambda) + \\
 & i\phi^0 (\bar{e}^\lambda \gamma^5 e^\lambda)] + \frac{ig}{2M\sqrt{2}} \phi^+ [-m_d^\lambda (\bar{u}_j^\lambda C_{\lambda\kappa} (1 - \gamma^5) d_j^\kappa) + m_u^\lambda (\bar{u}_j^\lambda C_{\lambda\kappa} (1 + \gamma^5) d_j^\kappa)] + \frac{ig}{2M\sqrt{2}} \phi^- [m_d^\lambda (\bar{d}_j^\lambda C_{\lambda\kappa}^\dagger (1 + \gamma^5) u_j^\kappa) - \\
 & m_u^\lambda (\bar{d}_j^\lambda C_{\lambda\kappa}^\dagger (1 - \gamma^5) u_j^\kappa)] - \frac{g}{2} \frac{m_\lambda^2}{M} H (\bar{u}_j^\lambda u_j^\lambda) - \frac{g}{2} \frac{m_\lambda^2}{M} H (\bar{d}_j^\lambda d_j^\lambda) + \frac{ig}{2} \frac{m_\lambda^2}{M} \phi^0 (\bar{u}_j^\lambda \gamma^5 u_j^\lambda) - \frac{ig}{2} \frac{m_\lambda^2}{M} \phi^0 (\bar{d}_j^\lambda \gamma^5 d_j^\lambda) + \bar{X}^+ (\partial^2 - \\
 & M^2) X^+ + \bar{X}^- (\partial^2 - M^2) X^- + \bar{X}^0 (\partial^2 - \frac{M^2}{c_w^2}) X^0 + \bar{Y} \partial^2 Y + igc_w W_\mu^+ (\partial_\mu \bar{X}^0 X^- - \partial_\mu \bar{X}^+ X^0) + ig s_w W_\mu^+ (\partial_\mu \bar{Y} X^- - \\
 & \partial_\mu \bar{X}^+ Y) + igc_w W_\mu^- (\partial_\mu \bar{X}^- X^0 - \partial_\mu \bar{X}^0 X^+) + ig s_w W_\mu^- (\partial_\mu \bar{X}^- Y - \partial_\mu \bar{Y} X^+) + igc_w Z_\mu^0 (\partial_\mu \bar{X}^- X^+ - \partial_\mu \bar{X}^+ X^-) + \\
 & ig s_w A_\mu (\partial_\mu \bar{X}^+ X^+ - \partial_\mu \bar{X}^- X^-) - \frac{1}{2}gM [\bar{X}^+ X^+ H + \bar{X}^- X^- H + \frac{1}{c_w^2} \bar{X}^0 X^0 H] + \frac{1-2c_w^2}{2c_w} igM [\bar{X}^- X^0 \phi^+ - \\
 & \bar{X}^- X^0 \phi^-] + \frac{1}{2c_w} igM [\bar{X}^0 X^- \phi^+ - \bar{X}^0 X^+ \phi^-] + igM s_w [\bar{X}^0 X^- \phi^+ - \bar{X}^0 X^+ \phi^-] + \frac{1}{2}igM [\bar{X}^- X^+ \phi^0 - \bar{X}^- X^- \phi^0]
 \end{aligned}$$

The Standard Model of Particle Physics



75

[<http://cern.ch/go/dW6z>]

$$\begin{aligned}
 & -\frac{1}{2}\partial_\nu g_\mu^a \partial_\nu g_\mu^a - g_s f^{abc} \partial_\mu g_\nu^a g_\mu^b g_\nu^c - \frac{1}{4}g_s^2 f^{abc} f^{ade} g_\mu^b g_\nu^c g_\mu^d g_\nu^e \\
 & \partial_\nu W_\mu^+ \partial_\nu W_\mu^- - M^2 W_\mu^+ W_\mu^- - \frac{1}{2}\partial_\nu Z_\mu^0 \partial_\nu Z_\mu^0 - \frac{1}{2c_w^2} M^2 Z_\mu^0 Z_\mu^0 \\
 & M^2 \phi^+ \phi^- - \frac{1}{2}\partial_\mu \phi^0 \partial_\mu \phi^0 - \frac{1}{2c_w^2} M \phi^0 \phi^0 - \beta_h \left[\frac{2M^2}{g^2} + \frac{2M}{g} H (W_\nu^+ W_\mu^-) - Z_\nu^0 (W_\mu^+ \partial_\nu W_\mu^- - W_\mu^- \partial_\nu W_\mu^+) + Z_\mu^0 (W_\nu^+ \partial_\mu W_\nu^- - W_\nu^- \partial_\mu W_\nu^+) \right. \\
 & \quad \left. + A_\nu (W_\mu^+ \partial_\nu W_\mu^- - W_\mu^- \partial_\nu W_\mu^+) + A_\mu (W_\nu^+ \partial_\mu W_\nu^- - W_\nu^- \partial_\mu W_\nu^+) \right. \\
 & \quad \left. + g^2 c_w^2 (Z_\mu^0 W_\mu^+ Z_\nu^0 W_\nu^- - Z_\mu^0 Z_\nu^0 W_\mu^+ W_\nu^-) + g^2 s_w^2 (A_\mu W_\nu^+ W_\mu^- - 2A_\mu Z_\mu^0 W_\nu^+ W_\nu^-) - g\alpha [H^3 + H\phi^0 \phi^0 + 2H\phi^+ \phi^-] \right. \\
 & \quad \left. + 4H^2 \phi^+ \phi^- + 2(\phi^0)^2 H^2 \right] - gM W_\mu^+ W_\mu^- H - \frac{1}{2}g \frac{M}{c_w} Z_\mu^0 Z_\mu^0 H \\
 & \frac{1}{2}g [W_\mu^+ (H\partial_\mu \phi^- - \phi^- \partial_\mu H) - W_\mu^- (H\partial_\mu \phi^+ - \phi^+ \partial_\mu H) + W_\mu^- \phi^+ + i g s_w M A_\mu (W_\mu^+ \phi^- - W_\mu^- \phi^+) - i g \frac{1-2c_w^2}{2c_w} Z_\mu^0 \phi^0 \\
 & \frac{1}{4}g^2 W_\mu^+ W_\mu^- [H^2 + (\phi^0)^2 + 2\phi^+ \phi^-] - \frac{1}{4}g^2 \frac{1}{c_w} Z_\mu^0 Z_\mu^0 [H^2 + (\phi^0)^2 + 2\phi^+ \phi^-] \\
 & W_\mu^- \phi^+ - \frac{1}{2}i g^2 \frac{s_w^2}{c_w} Z_\mu^0 H (W_\mu^+ \phi^- - W_\mu^- \phi^+) + \frac{1}{2}g^2 s_w A_\mu (W_\mu^+ \phi^- - W_\mu^- \phi^+) \\
 & g^2 \frac{s_w}{c_w} (2c_w^2 - 1) Z_\mu^0 A_\mu \phi^+ \phi^- - g^1 s_w^2 A_\mu A_\mu \phi^+ \phi^- - \bar{e}^\lambda (\gamma^\mu \partial_\mu e^\lambda) + i g s_w A_\mu [-(\bar{e}^\lambda \gamma^\mu e^\lambda) + \frac{2}{3}(\bar{u}_j^\lambda \gamma^\mu u_j^\lambda) - \frac{1}{3}(\bar{d}_j^\lambda \gamma^\mu d_j^\lambda)] + \frac{i g}{4c_w} Z_\mu^0 [(1 - \gamma^5) u_j^\lambda + (\bar{d}_j^\lambda \gamma^\mu (1 - \frac{8}{3}s_w^2 - \gamma^5) d_j^\lambda)] + \frac{i g}{2\sqrt{2}} W_\mu^+ [(\bar{\nu}^\lambda \gamma^\mu (1 - \gamma^5) \nu^\lambda) + (\bar{d}_j^\lambda C_{\lambda\kappa}^\dagger \gamma^\mu (1 + \gamma^5) u_j^\lambda)] + \frac{i g}{2\sqrt{2}} \frac{m_\lambda}{M} [-\phi^+ (\bar{\nu}^\lambda \gamma^\mu (1 - \gamma^5) \nu^\lambda) + (\bar{d}_j^\lambda C_{\lambda\kappa}^\dagger \gamma^\mu (1 + \gamma^5) u_j^\lambda)] + \frac{i g}{2M\sqrt{2}} \phi^+ [-m_d^\kappa (\bar{u}_j^\lambda C_{\lambda\kappa} (1 - \gamma^5) d_j^\kappa) + m_u^\kappa (\bar{d}_j^\lambda C_{\lambda\kappa}^\dagger (1 - \gamma^5) u_j^\kappa)] - \frac{g}{2} \frac{m_\lambda}{M} H (\bar{u}_j^\lambda u_j^\lambda) - \frac{g}{2} \frac{m_\lambda}{M} H (\bar{d}_j^\lambda d_j^\lambda) + \frac{i g}{2} \frac{m_\lambda}{M} \phi^0 (\bar{u}_j^\lambda \gamma^5 u_j^\lambda) - \frac{i g}{2} \frac{m_\lambda}{M} \phi^0 (\bar{d}_j^\lambda \gamma^5 d_j^\lambda) + \bar{X}^+ (\partial^2 - M^2) X^+ + \bar{X}^- (\partial^2 - M^2) X^- + \bar{X}^0 (\partial^2 - \frac{M^2}{c_w^2}) X^0 + \bar{Y} \partial^2 Y + i g c_w W_\mu^+ (\partial_\mu \bar{X}^0 X^- - \partial_\mu \bar{X}^+ X^0) + i g s_w W_\mu^+ (\partial_\mu \bar{Y} X^- - \partial_\mu \bar{X}^+ Y) + i g c_w W_\mu^- (\partial_\mu \bar{X}^- X^0 - \partial_\mu \bar{X}^0 X^+) + i g s_w W_\mu^- (\partial_\mu \bar{X}^- Y - \partial_\mu \bar{Y} X^+) + i g c_w Z_\mu^0 (\partial_\mu \bar{X}^- X^+ - \partial_\mu \bar{X}^+ X^-) + i g s_w A_\mu (\partial_\mu \bar{X}^+ X^+ - \partial_\mu \bar{X}^- X^-) - \frac{1}{2}g M [\bar{X}^+ X^+ H + \bar{X}^- X^- H + \frac{1}{c_w^2} \bar{X}^0 X^0 H] + \frac{1-2c_w^2}{2c_w} i g M [\bar{X}^+ X^0 \phi^+ - \bar{X}^- X^0 \phi^-] + \frac{1}{2c_w} i g M [\bar{X}^0 X^- \phi^+ - \bar{X}^0 X^+ \phi^-] + i g M s_w [\bar{X}^0 X^- \phi^+ - \bar{X}^0 X^+ \phi^-] + \frac{1}{2}i g M [\bar{X}^+ X^+ \phi^0 - \bar{X}^- X^- \phi^0]
 \end{aligned}$$



The Standard Model of Particle Physics



76

Electromagnetic force – light

Weak force – star combustion

Strong force – protons and neutrons

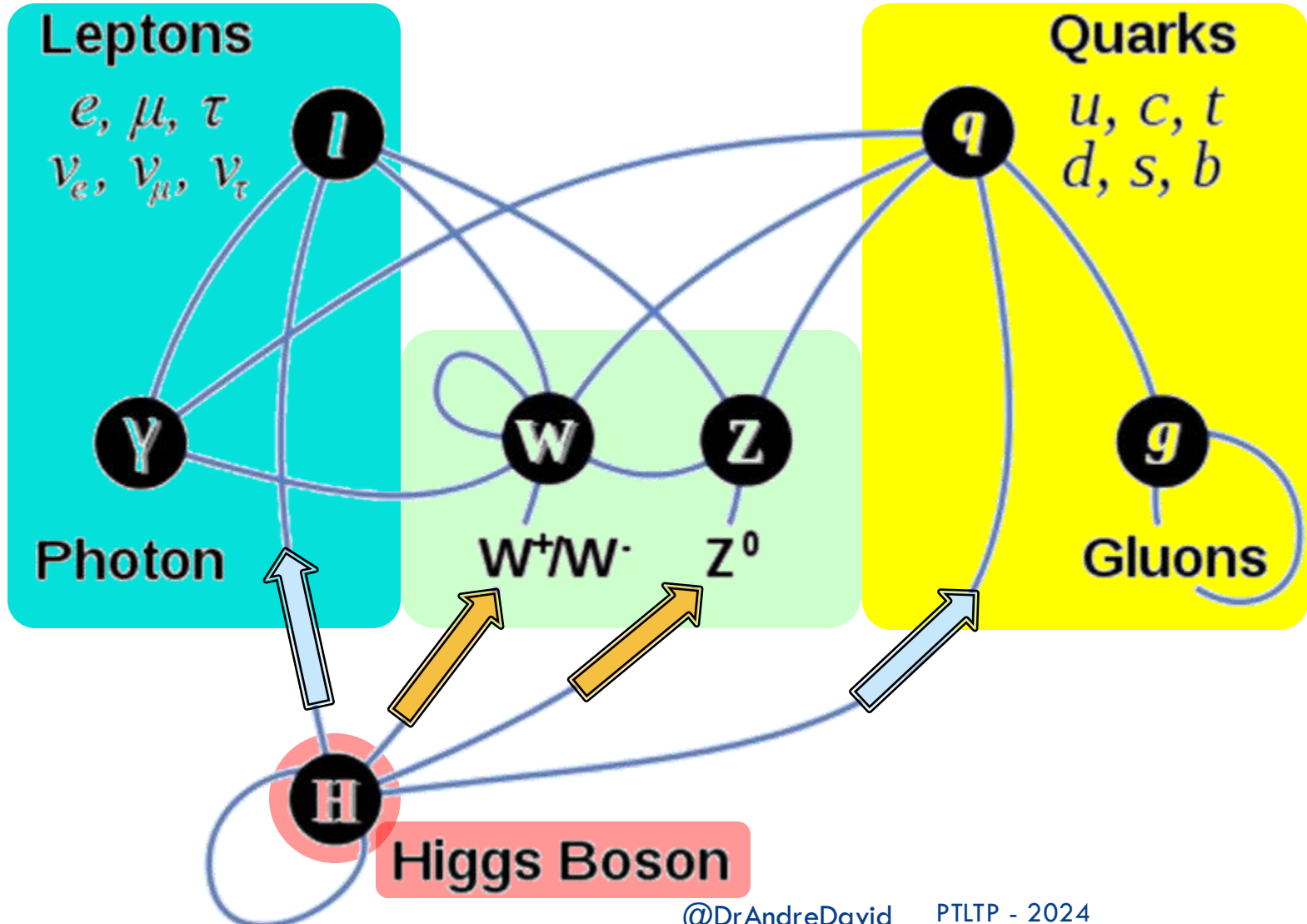



How SM Higgses are born



77

[<http://cern.ch/go/cWH8>] [<http://cern.ch/go/SnJ8>]

□ **Gluon fusion**

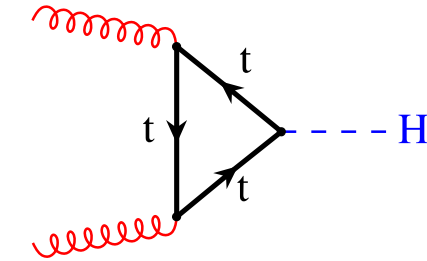

□ **VBF**

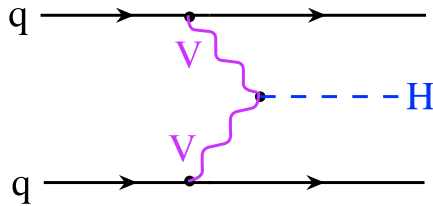

□ **WH, ZH**

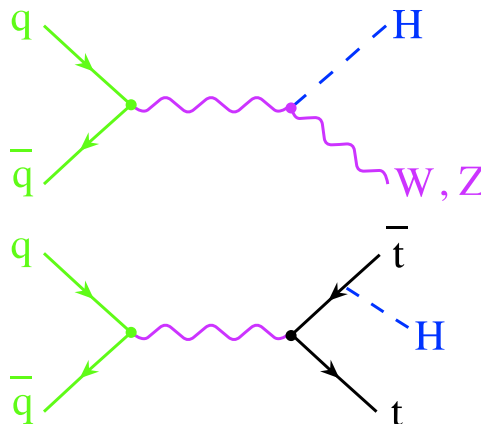

□ **bbH, ttH**

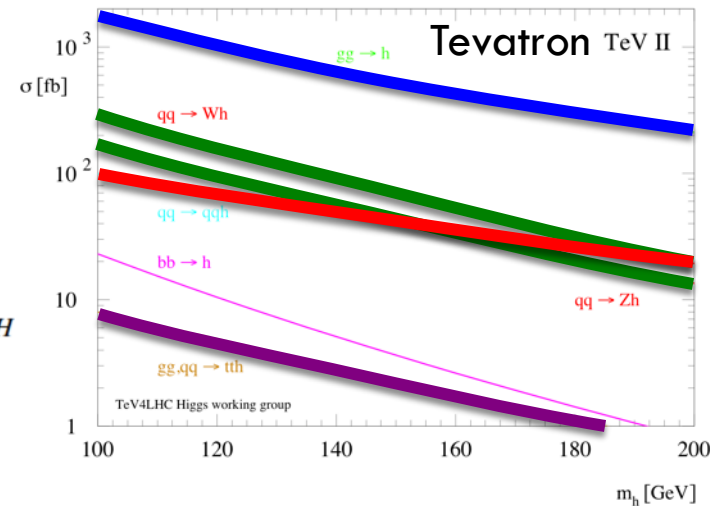
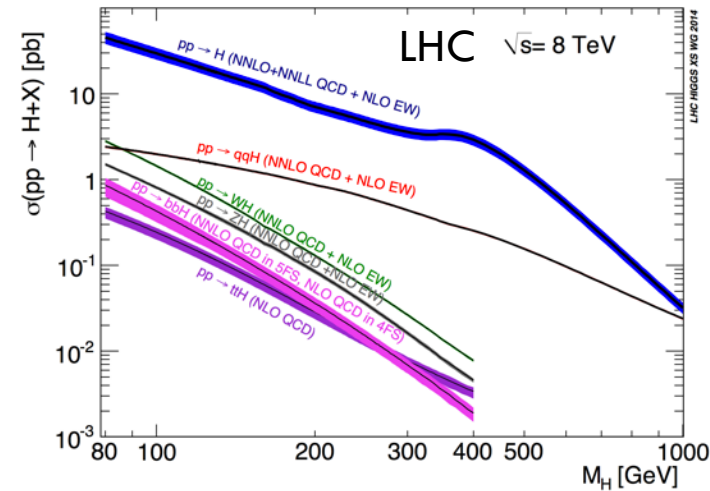
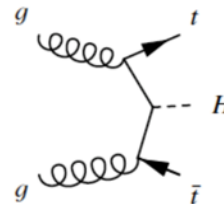

How SM Higgses die



- Couplings and kinematics drive BR ($b\bar{b}$, WW , $\tau\tau$, ZZ).
- ▣ Decays with photons ($\gamma\gamma$, $Z\gamma$) through loops.

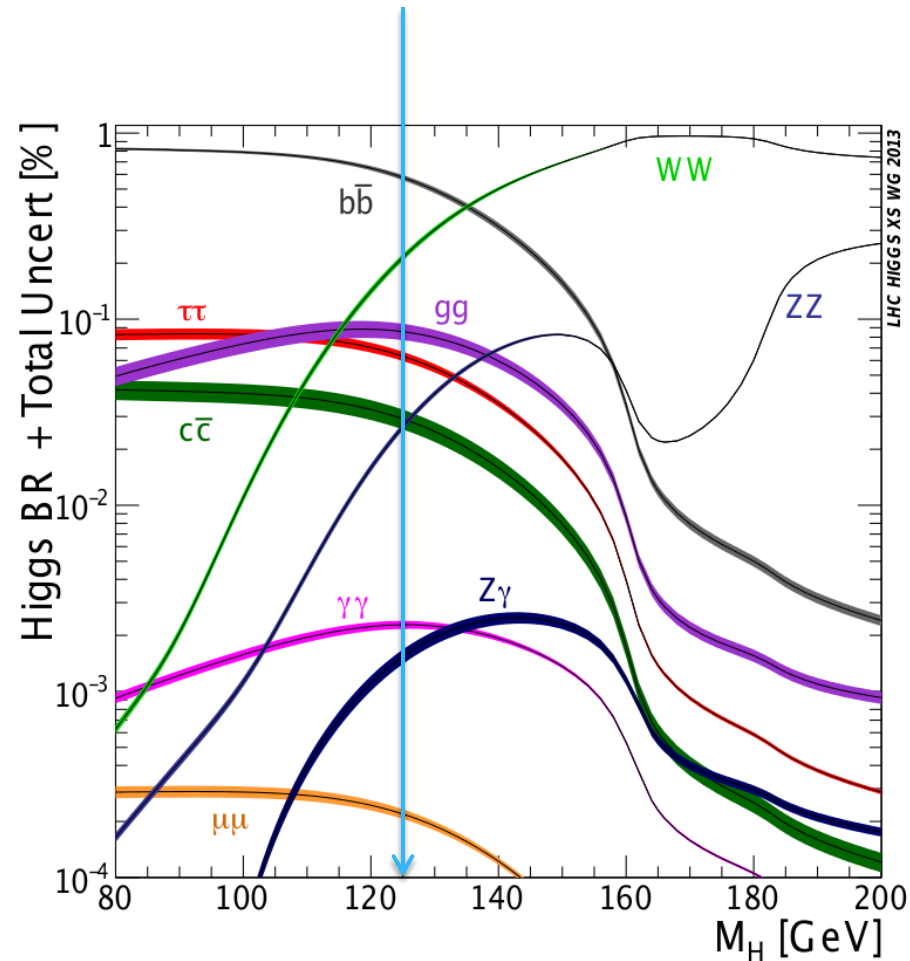
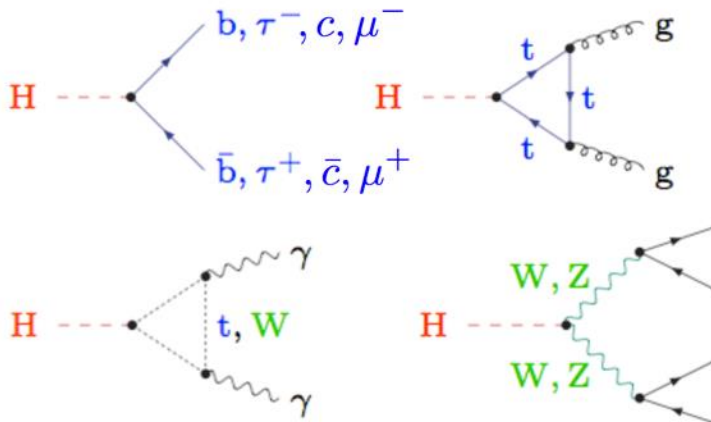

Putting it all together



$$\begin{aligned}
 & -\frac{1}{2}g_2^2\partial_\mu\phi_\nu^2 - g_1f^{abc}\partial_\mu\phi_\nu^2\phi_\rho^2 - \frac{1}{2}g_1^2f^{abc}f^{def}\partial_\mu\phi_\nu^2\phi_\rho^2\phi_\sigma^2 + \frac{1}{2}g_2^2(\partial_\mu\gamma^\nu\phi_\rho^2)g_\sigma^\mu + G^{\mu\nu}G^\sigma + g_1f^{abc}\partial_\mu G^\nu G^\sigma\phi_\rho^2 - \\
 & \partial_\mu W_\nu^+ \partial_\mu W_\nu^- - M^2 W_\nu^+ W_\nu^- - \frac{1}{2}\partial_\mu Z_\nu^2 Z_\nu^2 - \frac{1}{2}M^2 Z_\nu^2 Z_\nu^2 + \frac{1}{2}\partial_\mu A_\nu \partial_\mu A_\nu - \frac{1}{2}\partial_\mu H \partial_\mu H - \frac{1}{2}m_H^2 H^2 - \partial_\mu \phi^+ \partial_\mu \phi^- - \\
 & M^2 \phi^+ \phi^- - \frac{1}{2}g_2^2 \partial_\mu \phi^+ \phi^- - \frac{1}{2}M\phi^+ \phi^- - \frac{3}{2}(M^2 + \frac{1}{2}M^2 H + \frac{1}{2}(H^2 + \phi^+ \phi^- + 2\phi^+ \phi^-)) + \frac{1}{2}g_2^2 \phi_\mu^+ \partial_\nu \phi_\nu^2 (W_\nu^+ W_\nu^- - \\
 & W_\nu^- W_\nu^+) - Z_\nu^2 (W_\nu^+ \partial_\mu W_\nu^- - W_\nu^- \partial_\mu W_\nu^+) + Z_\nu^2 (W_\nu^+ \partial_\mu W_\nu^- - W_\nu^- \partial_\mu W_\nu^+) - ig_2 g_1 \partial_\mu A_\nu (W_\nu^+ W_\nu^- - W_\nu^- W_\nu^+) - \\
 & A_\nu (W_\nu^+ \partial_\mu W_\nu^- - W_\nu^- \partial_\mu W_\nu^+) + A_\nu (W_\nu^+ \partial_\mu W_\nu^- - W_\nu^- \partial_\mu W_\nu^+) - \frac{1}{2}g_2^2 W_\nu^+ W_\nu^- W_\nu^+ W_\nu^- + \frac{1}{2}g_2^2 W_\nu^+ W_\nu^- W_\nu^+ W_\nu^- + \\
 & g_1^2 \partial_\mu^2 (Z_\nu^2 W_\nu^+ Z_\nu^2 W_\nu^- - Z_\nu^2 Z_\nu^2 W_\nu^+ W_\nu^-) + g_1^2 \partial_\mu^2 (A_\nu W_\nu^+ A_\nu W_\nu^- - A_\nu A_\nu W_\nu^+ W_\nu^-) + g_1^2 g_2 g_1 A_\nu Z_\nu^2 (W_\nu^+ W_\nu^- - \\
 & W_\nu^- W_\nu^+) - 2A_\nu Z_\nu^2 W_\nu^+ W_\nu^- - g_0(H^2 + H\phi^+ \phi^- + 2H\phi^+ \phi^-) - \frac{1}{2}g_1^2 \phi_\mu^+ (H^2 + (\phi^+)^2 + 4(\phi^+ \phi^-)^2 + 4(\phi^+)^2 \phi^- \phi^- + \\
 & 4H\phi^+ \phi^- + 2(\phi^+)^2 H^2) - g_1 M W_\nu^+ W_\nu^- H - \frac{1}{2}g_2^2 Z_\nu^2 Z_\nu^2 H - \frac{1}{2}g_1^2 (W_\nu^+ \partial_\mu \phi^+ \phi^- - \phi^- \partial_\mu \phi^+) - W_\nu^+ (\phi^+ \partial_\mu \phi^- - \phi^- \partial_\mu \phi^+) + \\
 & \frac{1}{2}g_1^2 (W_\nu^+ (H\partial_\mu \phi^- - \phi^- \partial_\mu H) - W_\nu^- (H\partial_\mu \phi^+ - \phi^+ \partial_\mu H)) + \frac{1}{2}g_2^2 (Z_\nu^2 (H\partial_\mu \phi^+ - \phi^+ \partial_\mu H) - ig_2^2 M Z_\nu^2 (W_\nu^+ \phi^- - \\
 & W_\nu^- \phi^+) + ig_2 g_1 M A_\nu (W_\nu^+ \phi^- - W_\nu^- \phi^+) - ig_2^2 \frac{M^2}{2} Z_\nu^2 (\phi^+ \partial_\mu \phi^- - \phi^- \partial_\mu \phi^+) + ig_2 g_1 A_\nu (\phi^+ \partial_\mu \phi^- - \phi^- \partial_\mu \phi^+) - \\
 & \frac{1}{2}g_2^2 W_\nu^+ W_\nu^- (H^2 + (\phi^+)^2 + 2\phi^+ \phi^-) - \frac{1}{2}g_1^2 \frac{M^2}{2} Z_\nu^2 (H^2 + (\phi^+)^2 + 2(2\phi^+ - 1)\phi^+ \phi^-) - \frac{1}{2}g_1^2 \frac{M^2}{2} Z_\nu^2 \phi^0 (W_\nu^+ \phi^- + \\
 & W_\nu^- \phi^+) - \frac{1}{2}g_1^2 \frac{M^2}{2} Z_\nu^2 H (W_\nu^+ \phi^- - W_\nu^- \phi^+) + \frac{1}{2}g_1^2 g_2 A_\nu \phi^0 (W_\nu^+ \phi^- + W_\nu^- \phi^+) + \frac{1}{2}g_1^2 g_2 A_\nu H (W_\nu^+ \phi^- - W_\nu^- \phi^+) - \\
 & g_1^2 \frac{M^2}{2} (2\phi^+ - 1) Z_\nu^2 A_\nu \phi^0 \phi^- - g_1^2 \frac{M^2}{2} A_\nu \phi^0 \phi^- - g_1^2 (\gamma_0 + m_\phi^2) \phi^+ - g_1^2 \gamma_0 \phi^+ - g_1^2 (\gamma_0 + m_\phi^2) \phi^- - g_1^2 (\gamma_0 + m_\phi^2) \phi^- + \\
 & ig_2 g_1 A_\nu [-(\phi^+ \gamma^0 \phi^+) + \frac{1}{2}(\phi^+ \gamma^0 \phi^+)] - \frac{1}{2}(\phi^+ \gamma^0 \phi^+) + \frac{1}{2}Z_\nu^2 ((\phi^+ \gamma^0 (1 + \gamma^5) \phi^+) + (\phi^+ \gamma^0 (4\phi^+ - 1 - \gamma^5) \phi^-) + (\phi^+ \gamma^0 [\frac{1}{2}\phi^+ - \\
 & 1 - \gamma^5] \phi^-) + (\phi^+ \gamma^0 (1 - \frac{1}{2}\phi^+ - \gamma^5) \phi^-)] + \frac{1}{2}g_2^2 W_\nu^+ [(\phi^+ \gamma^0 (1 + \gamma^5) \phi^+) + (\phi^+ \gamma^0 (1 + \gamma^5) C_{\mu\nu} \phi^-)] + \frac{1}{2}g_2^2 W_\nu^- [(\phi^+ \gamma^0 (1 + \\
 & \gamma^5) \phi^+) + (\phi^+ C_{\mu\nu} \gamma^0 (1 + \gamma^5) \phi^-)] + \frac{1}{2}g_2^2 W_\nu^+ [-(\phi^+ \gamma^0 (1 - \gamma^5) \phi^-) + \phi^- (\phi^+ (1 + \gamma^5) \phi^-)] - \frac{1}{2}g_2^2 H (\phi^+ \phi^-) + \\
 & i\phi^0 (\phi^+ \phi^-) + \frac{1}{2}g_2^2 \gamma_0^2 [1 - m_\phi^2] C_{\mu\nu} (1 - \gamma^5) \phi^- + m_\phi^2 [g_2^2 C_{\mu\nu} (1 + \gamma^5) \phi^-] + \frac{1}{2}g_2^2 \gamma_0^2 [m_\phi^2 \partial_\mu^2 C_{\mu\nu} (1 + \gamma^5) \phi^-] - \\
 & m_\phi^2 \partial_\mu^2 C_{\mu\nu} (1 - \gamma^5) \phi^- - \frac{1}{2}g_2^2 H (g_2^2 \phi^+) - \frac{1}{2}g_2^2 H (g_2^2 \phi^-) + \frac{1}{2}g_2^2 \phi^0 (\phi^+ \gamma^0 \phi^+) - \frac{1}{2}g_2^2 \phi^0 (\phi^+ \gamma^0 \phi^+) + X^+ (\phi^+ - \\
 & M^2 X^+ + X^+ (\phi^+ - M^2 X^+ + X^+ \phi^+ - \frac{1}{2}M^2 X^+ + X^+ \phi^+) + ig_2 W_\nu^+ (\partial_\mu X^+ X^+ - \partial_\mu X^+ X^+) + ig_2 W_\nu^- (\partial_\mu X^+ X^+ - \\
 & \partial_\mu X^+ X^+) + ig_2 W_\nu^+ (\partial_\mu X^- X^- - \partial_\mu X^- X^-) + ig_2 W_\nu^- (\partial_\mu X^- X^- - \partial_\mu X^- X^-) + ig_2 Z_\nu^2 (\partial_\mu X^+ X^- - \partial_\mu X^- X^+) + \\
 & ig_2 A_\nu (\partial_\mu X^+ X^- - \partial_\mu X^- X^+) - \frac{1}{2}g_1 M [X^+ X^- H + X^- X^+ H + \frac{1}{2}X^+ X^+ H] + \frac{1}{2}g_1 M [X^+ X^+ X^+ \phi^- \\
 & X^- X^+ \phi^-] + \frac{1}{2}g_1 M [X^+ X^- \phi^- - X^- X^+ \phi^-] + ig_2 M_\mu [X^+ X^- \phi^- - X^- X^+ \phi^-] + \frac{1}{2}g_1 M [X^+ X^+ \phi^- - X^- X^- \phi^-]
 \end{aligned}$$





2011: nothing else in the horizon

80

["Lawrence of Arabia" idea from C. Grojean]

- We first saw that we could not exclude a narrow range.



2011: nothing else in the horizon

- We first saw that we could not exclude a narrow range.

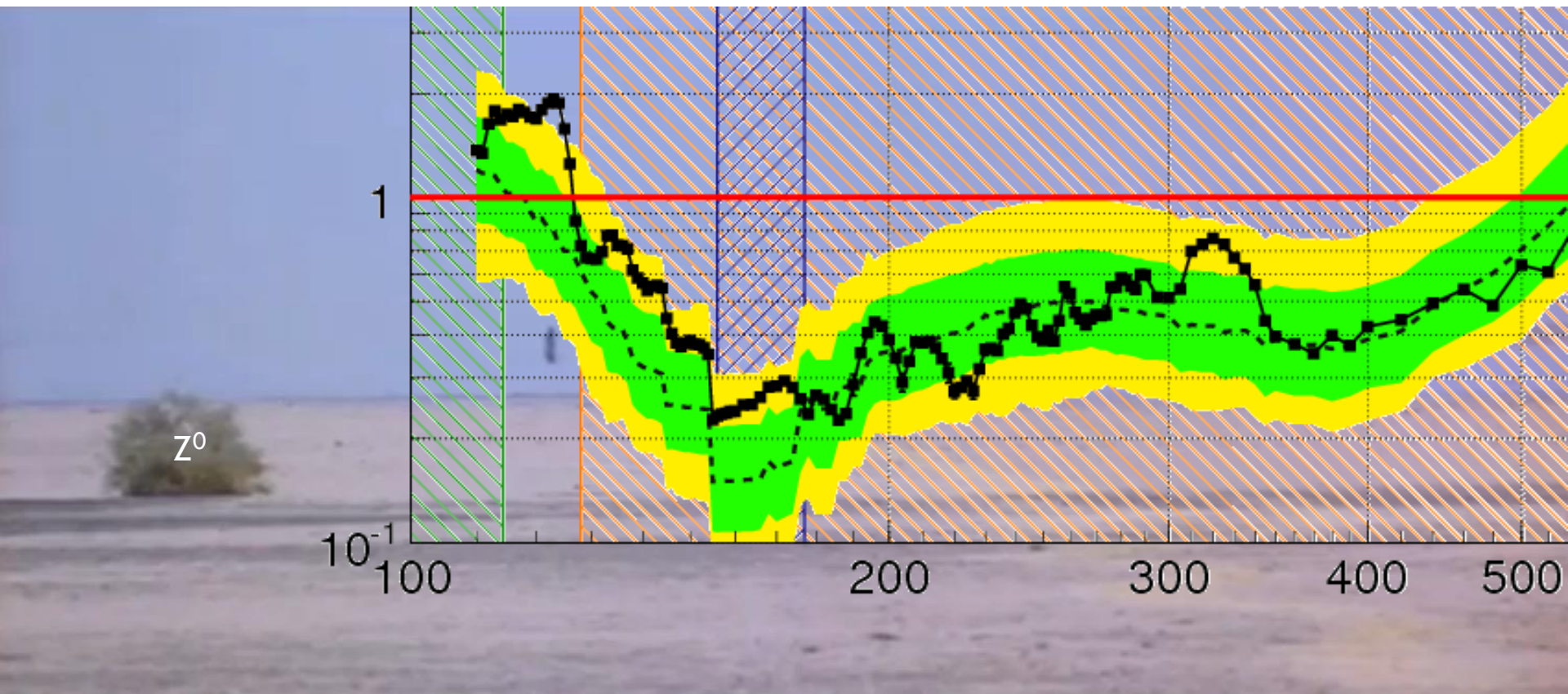



2012: a rider!

82

["Lawrence of Arabia" idea from C. Grojean]

- We discovered a peak rising from the background.



July 4, 2012

Looking up to a new boson

83

[<http://cern.ch/go/q8jx>]

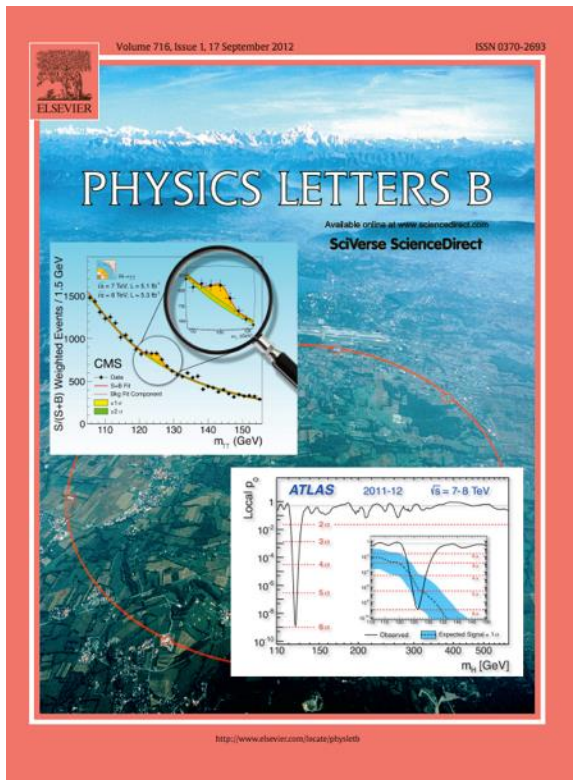

Higgsdependence day recap



- **Both experiments at 5.0σ .**
 - One above SM expectations...
 $\sigma_{\text{ATLAS}}/\sigma_{\text{SM}} = 1.2 \pm 0.3$ (at 126.5 GeV).
 - ...the other one below.
 $\sigma_{\text{CMS}}/\sigma_{\text{SM}} = 0.80 \pm 0.20$ (at 125 GeV).
- Mass
 - ATLAS: min. p-value at 126.5 GeV.
 - CMS: $m_{\chi} = 125.3 \pm 0.6$ GeV.
- “Proto-couplings” compatible with SM.
- **“More data needed...”**

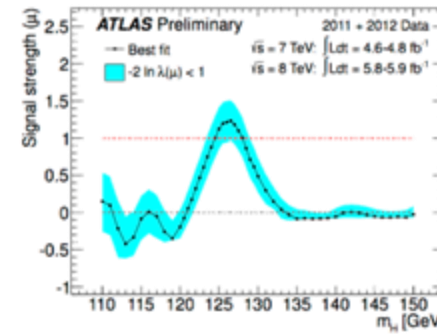
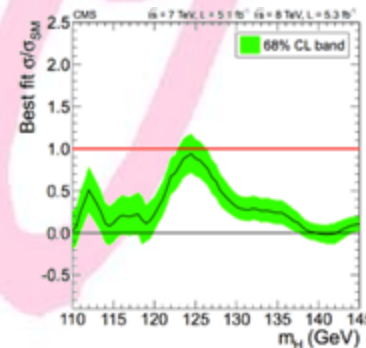
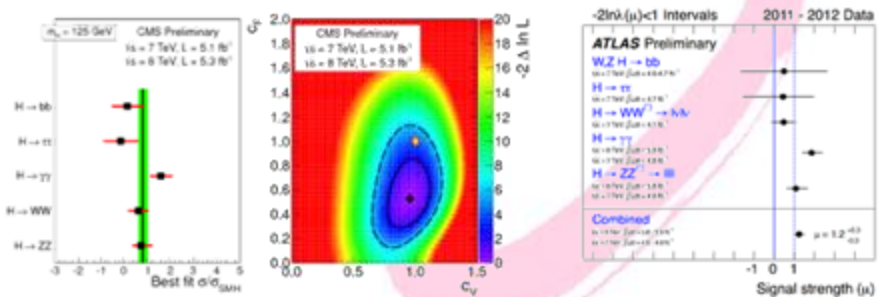
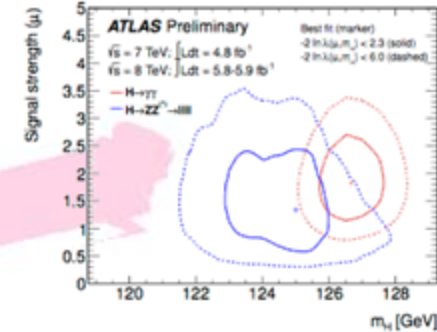
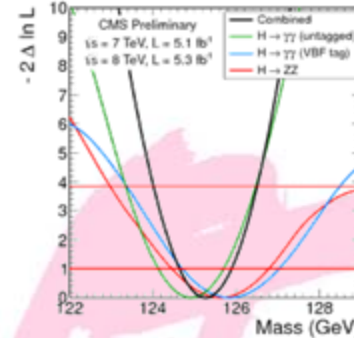
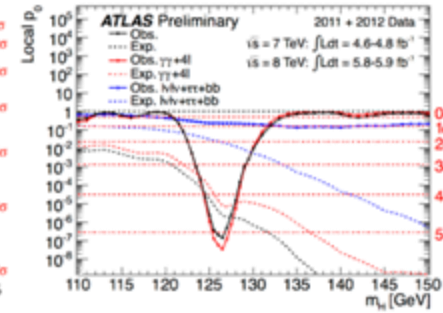
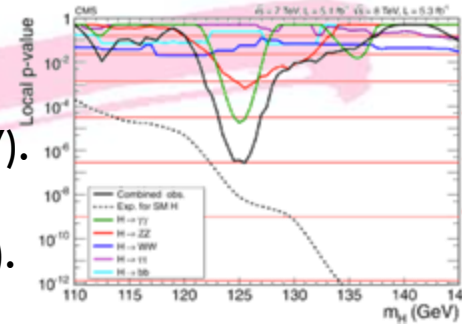

Evolutions & revolutions of the elements



85

The Standard Model of particle physics

Years from concept to discovery

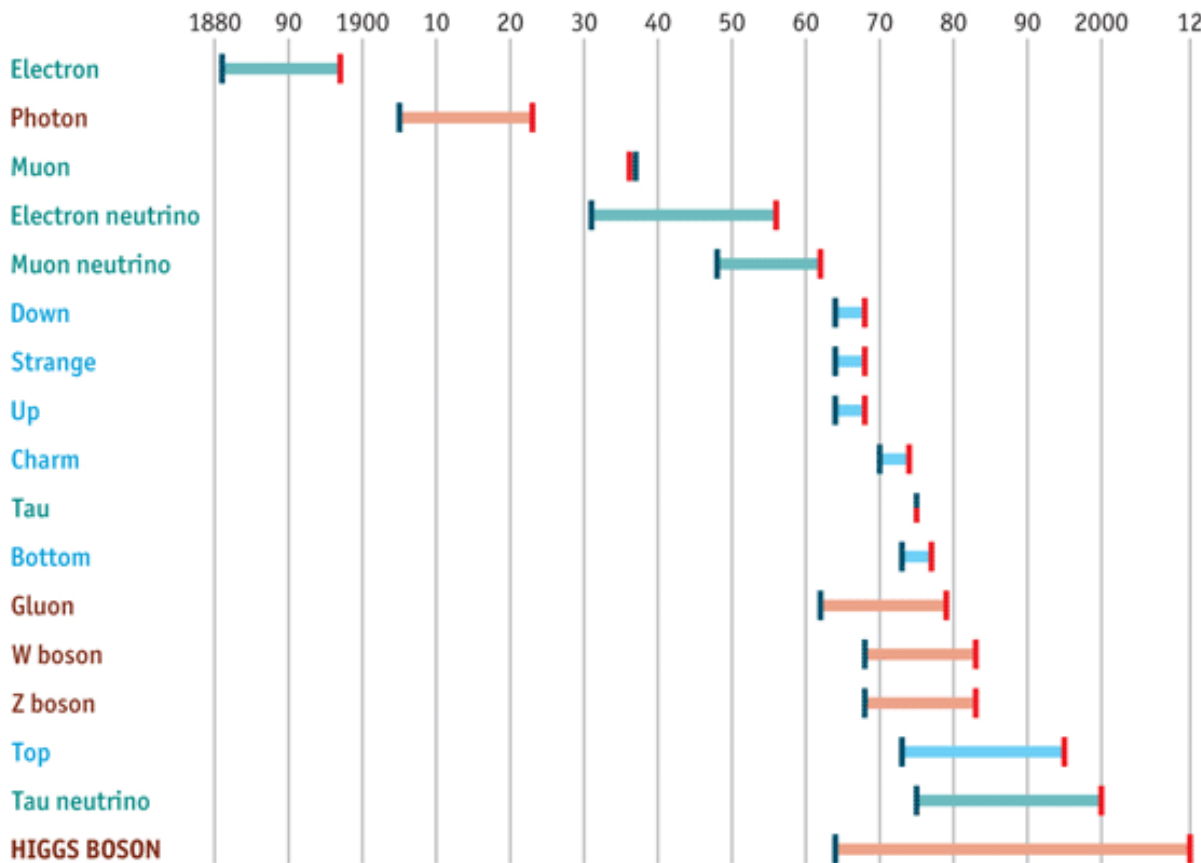

Source: *The Economist*

Evolutions & revolutions of the elements



86

The Standard Model of particle physics

Years from concept to discovery

Leptons
Bosons
Quarks
Theorised/explained
Discovered

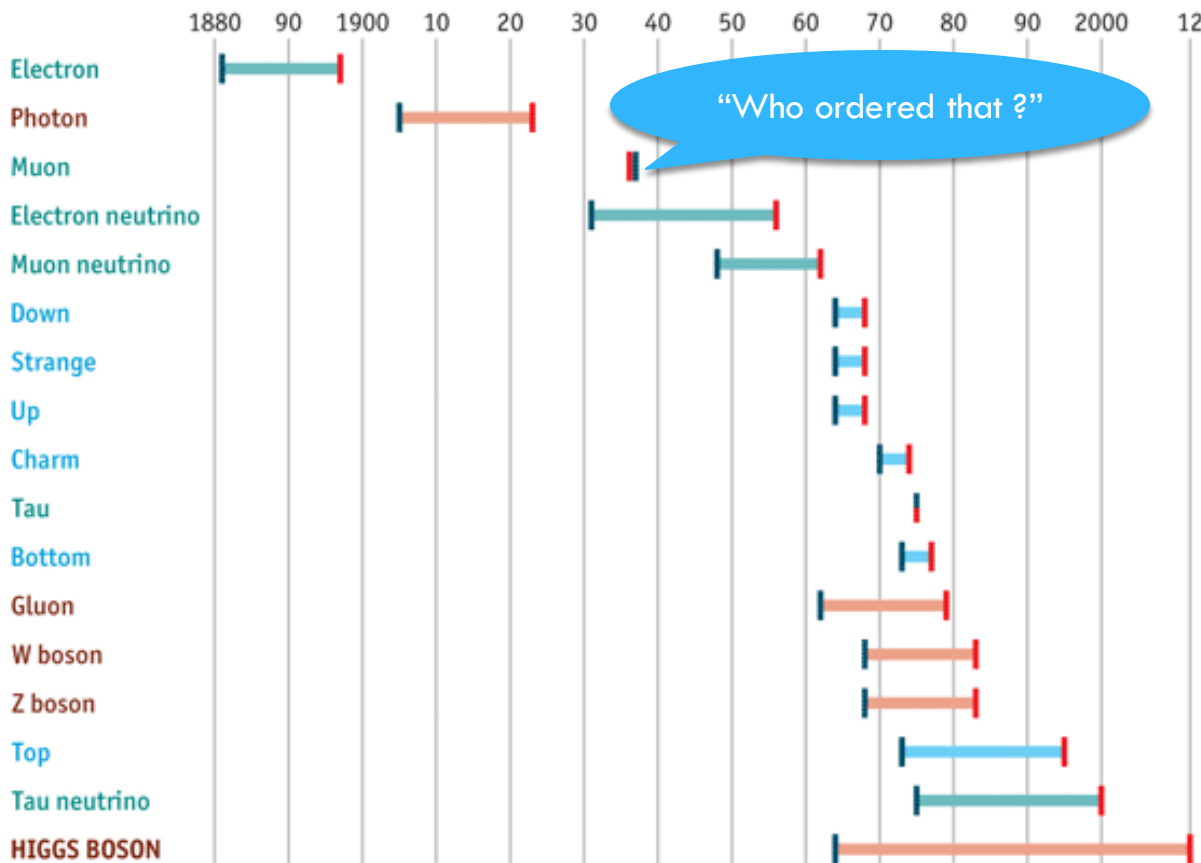

“Who ordered that ?”

Source: *The Economist*

Evolutions & revolutions of the elements



The Standard Model of particle physics

Years from concept to discovery

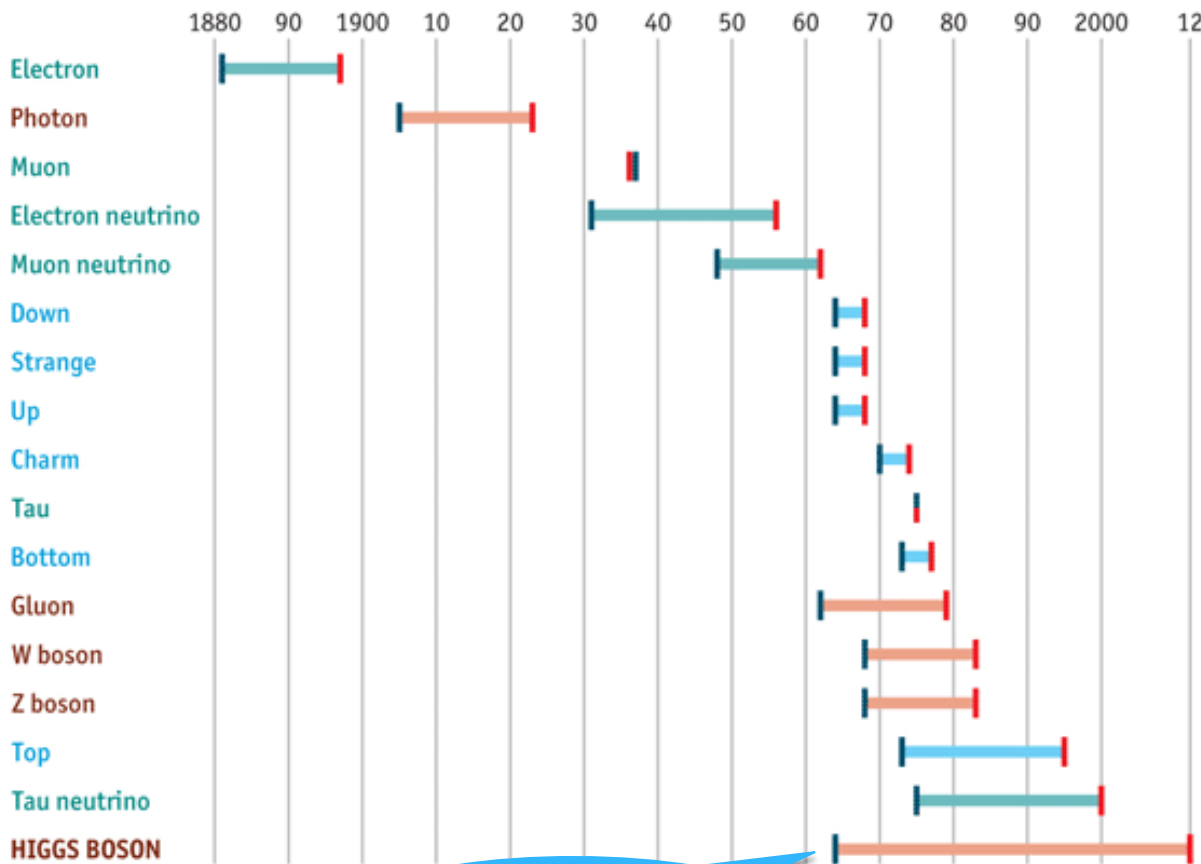

Source: *The Economist*

Almost 50 years !

2012 2011 2010 2009 2008

Who Should Be TIME's Person of the Year 2012? >

As always, TIME's editors will choose the Person of the Year, but that doesn't mean readers shouldn't have their say. Cast your vote for the person you think most influenced the news this year for better or worse. Voting closes at 11:59 p.m. on Dec. 12, and the winner will be announced on Dec. 14.

Like 1.5k Tweet 536 +1 20 Share 7

THE CANDIDATES

The Higgs Boson

By Jeffrey Kluger | Monday, Nov. 26, 2012

◀ 18 of 40 ▶

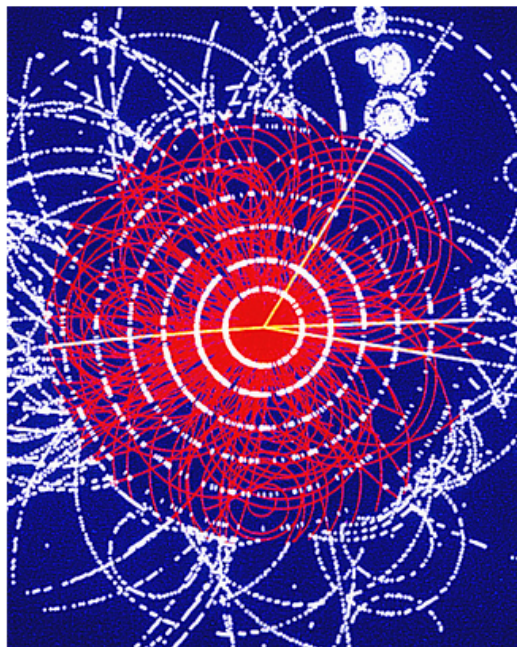

SSPL/GETTY IMAGES

Simulation of a Higgs-Boson decaying into four muons, CERN, 1990.

What do you think?

Should **The Higgs Boson** be TIME's Person of the Year 2012?

Definitely No Way

VOTE

Take a moment to thank this little particle for all the work it does, because without it, you'd be just inchoate energy without so much as a bit of mass. What's more, the same would be true for the entire universe. It was in the 1960s that Scottish physicist Peter Higgs first posited the existence of a particle that causes energy to make the jump to matter. But it was not until last summer that a team of researchers at Europe's Large Hadron Collider — Rolf Heuer, Joseph Incandela and Fabiola Gianotti — at last sealed the deal and in so doing finally fully confirmed Einstein's general theory of relativity. The Higgs — as particles do — immediately decayed to more-fundamental particles, but the scientists would surely be happy to collect any honors or awards in its stead.

Photos: Step inside the Large Hadron Collider.

WHO SHOULD BE TIME'S PERSON OF THE YEAR 2012?

The Candidates

Video

Poll Results

PAST PERSONS OF THE YEAR



2011: The Protester

2010: Facebook's Mark Zuckerberg



2009: Ben Bernanke



2008: Barack Obama

Most Read

Most Emailed

- 1 Who Should Be TIME's Person of the Year 2012?
- 2 LIFE Behind the Picture: The Photo That Changed the Face of AIDS
- 3 Nativity-Scene Battles: Score One for the Atheists
- 4 The \$7 Cup of Starbucks: A Logical Extension of the Coffee Chain's Long-Term Strategy

2012 2011 2010 2009 2008

Who Should Be TIME's Person of the Year 2012? >

As always, TIME's editors will choose the Person of the Year, but that doesn't mean readers shouldn't have their say. Cast your vote for the person you think most influenced the news this year for better or worse. Voting closes at 11:59 p.m. on Dec. 12, and the winner will be announced on Dec. 14.

Like 1.5k Tweet 536 +1 20 Share 7

THE CANDIDATES

The Higgs Boson

By Jeffrey Kluger | Monday, Nov. 26, 2012

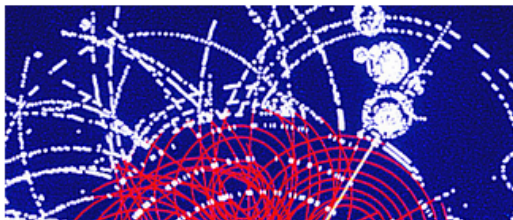

What do you think?

Should The Higgs Boson be TIME's Person of the Year 2012?

Definitely No Way

VOTE

◀ 18 of 40 ▶

WHO SHOULD BE TIME'S PERSON OF THE YEAR 2012?

The Candidates

Video

Poll Results

PAST PERSONS OF THE YEAR



2011: The Protester



2010: Facebook's Mark Zuckerberg



last summer that a team of researchers at Europe's Large Hadron Collider — Rolf Heuer, Joseph Incandela and Fabiola Gianotti — at last sealed the deal and in so doing finally fully confirmed Einstein's general theory of relativity. The

On the shoulders of giants

detector makers & theory calculators

Inelastic collisions: $\sim 7 \times 10^{10}$
May 2020

CMS Preliminary

Eight orders of magnitude of EWK, top, and Higgs Physics

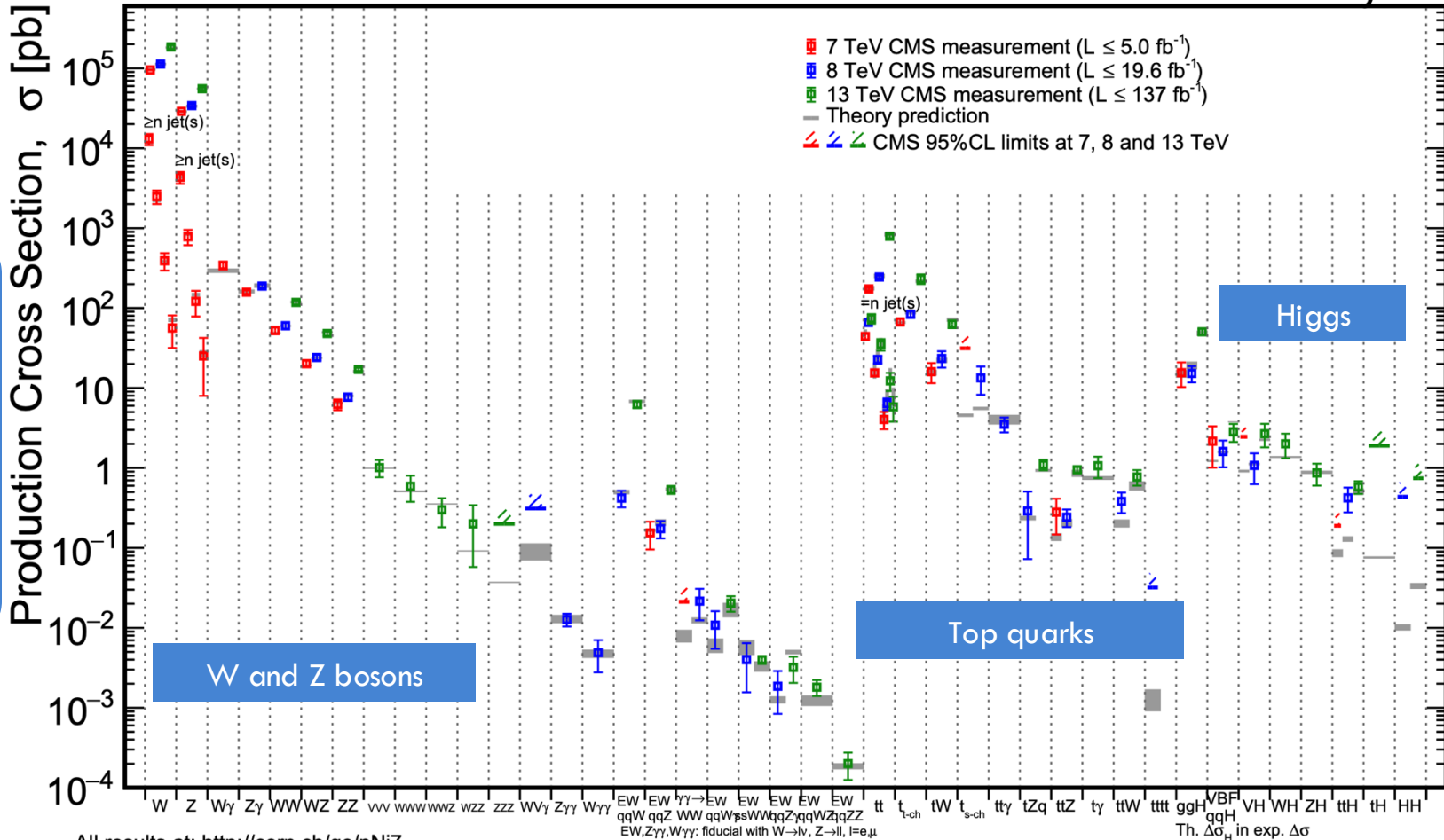



2013: a rider with a gun

91

["Lawrence of Arabia" idea from C. Grojean]

- By early 2013 a clear Higgs-like picture emerged.





Nobel prizes...

92



The Nobel Prize in Physics 2013

François Englert, Peter Higgs

Share this: [f](#) [g+](#) [t](#) [+](#) [1.8K](#) [e](#)

The Nobel Prize in Physics 2013



Photo: A. Mahmoud

François Englert

Prize share: 1/2



Photo: A. Mahmoud

Peter W. Higgs

Prize share: 1/2

The Nobel Prize in Physics 2013 was awarded jointly to François Englert and Peter W. Higgs *"for the theoretical discovery of a mechanism that contributes to our understanding of the origin of mass of subatomic particles, and which recently was confirmed through the discovery of the predicted fundamental particle, by the ATLAS and CMS experiments at CERN's Large Hadron Collider"*

Nobel prizes...



 The Nobel Prize in Physics 2013
François Englert, Peter Higgs

Share this:     1.8K 

The Nobel Prize 2013



Photo: A. Mahmoud
François Englert
Prize share: 1/2



Photo: A. Mahmoud
Peter W. Higgs
Prize share: 1/2

The Nobel Prize in Physics 2013 was awarded to François Englert and Peter W. Higgs "for the theoretical mechanism that contributes to our understanding of the mass of subatomic particles, and which results through the discovery of the predicted fundamental particles at the ATLAS and CMS experiments at CERN's Large Hadron Collider".

HÄDRÖNN CJÖLIDDER

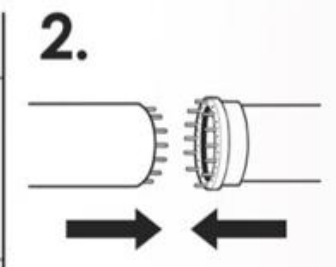
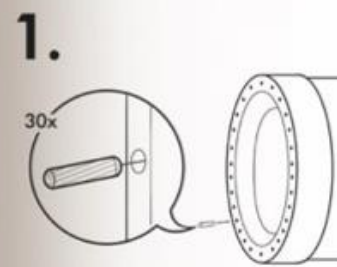
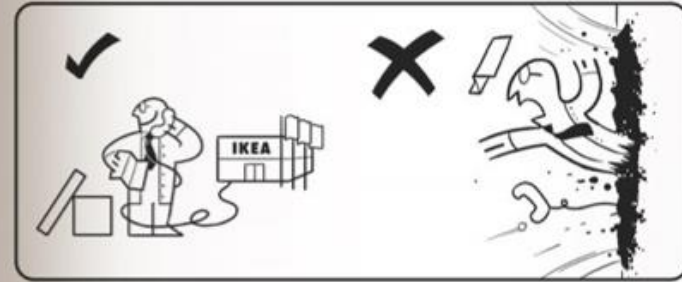
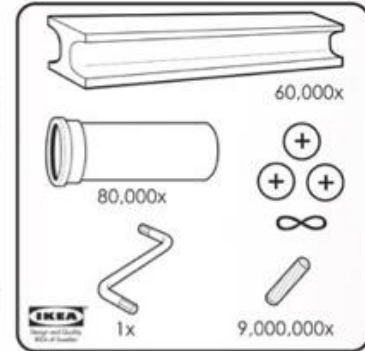
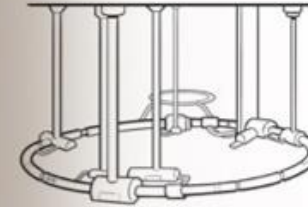

What is the Higgs boson mass?

Something that the SM does not predict.

Something we can measure!

Mass peaks: mass measurements

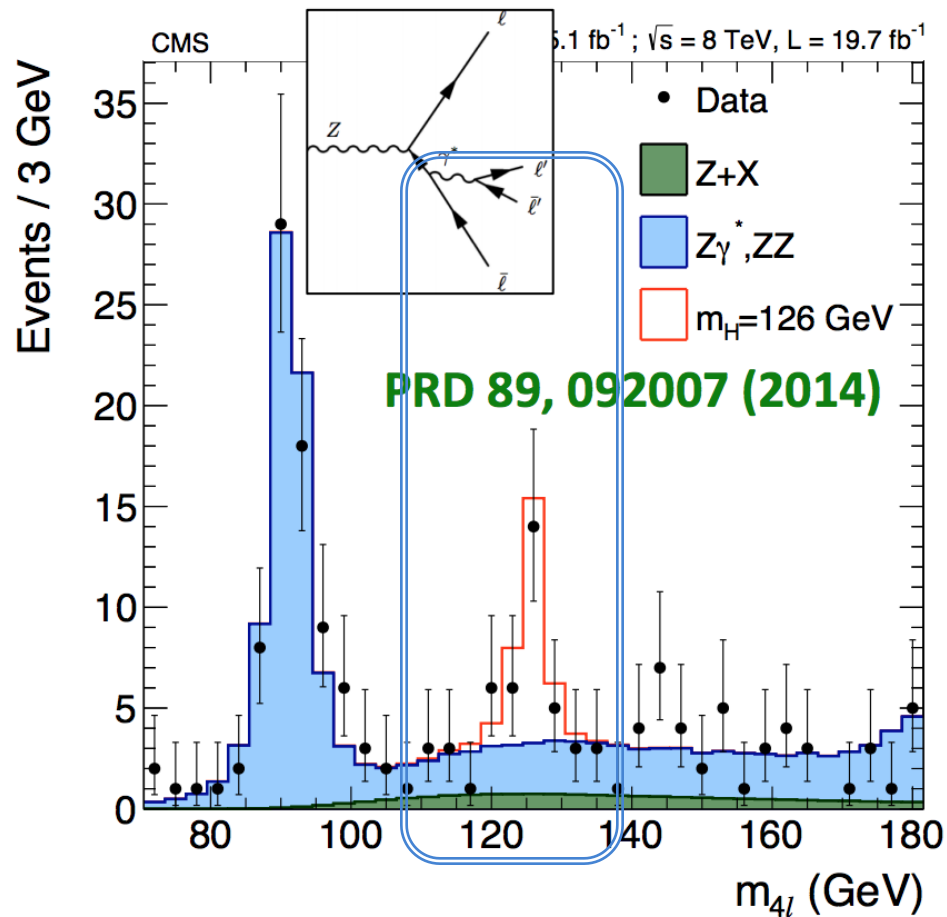
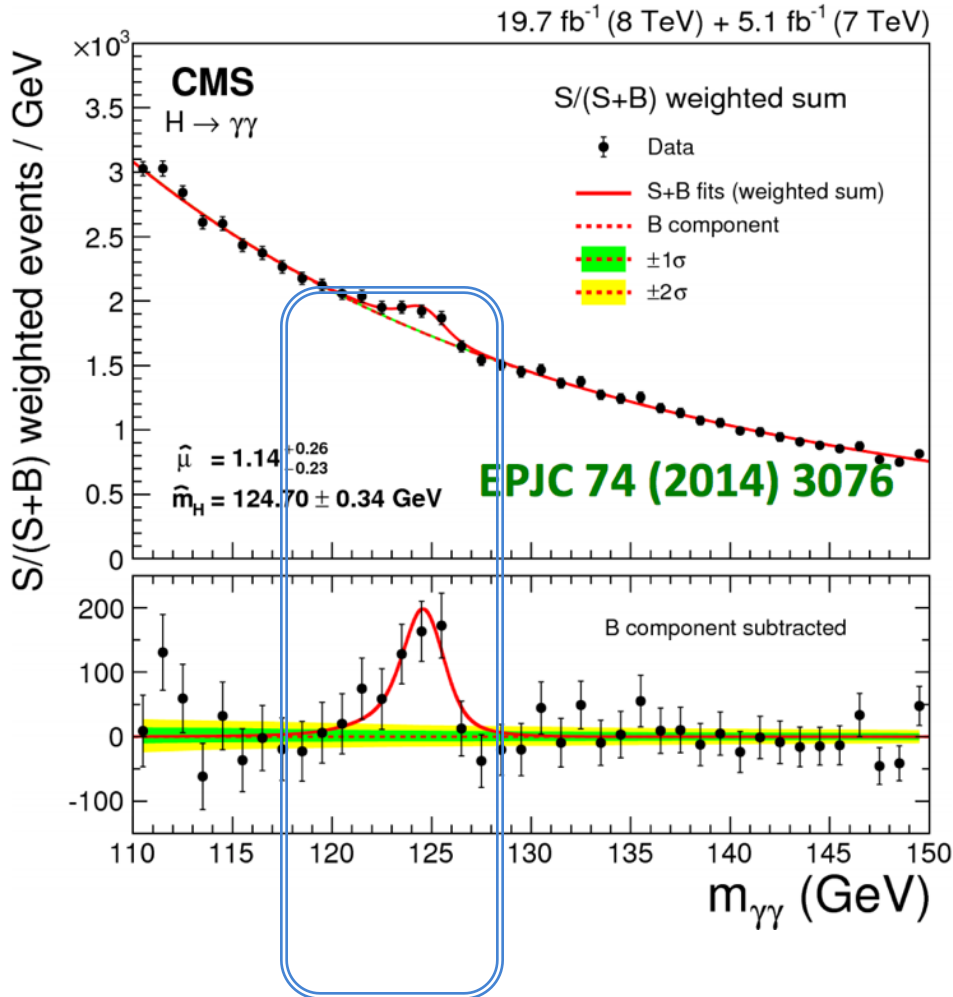

Mass peaks: mass measurements

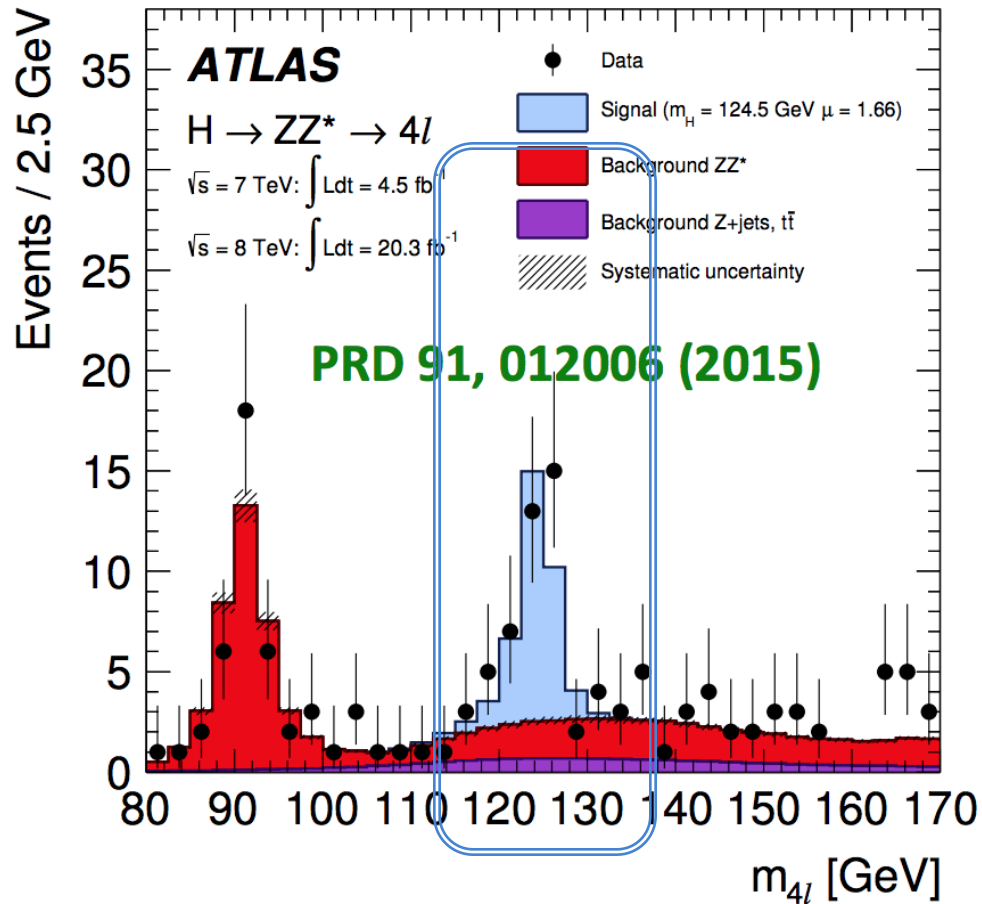
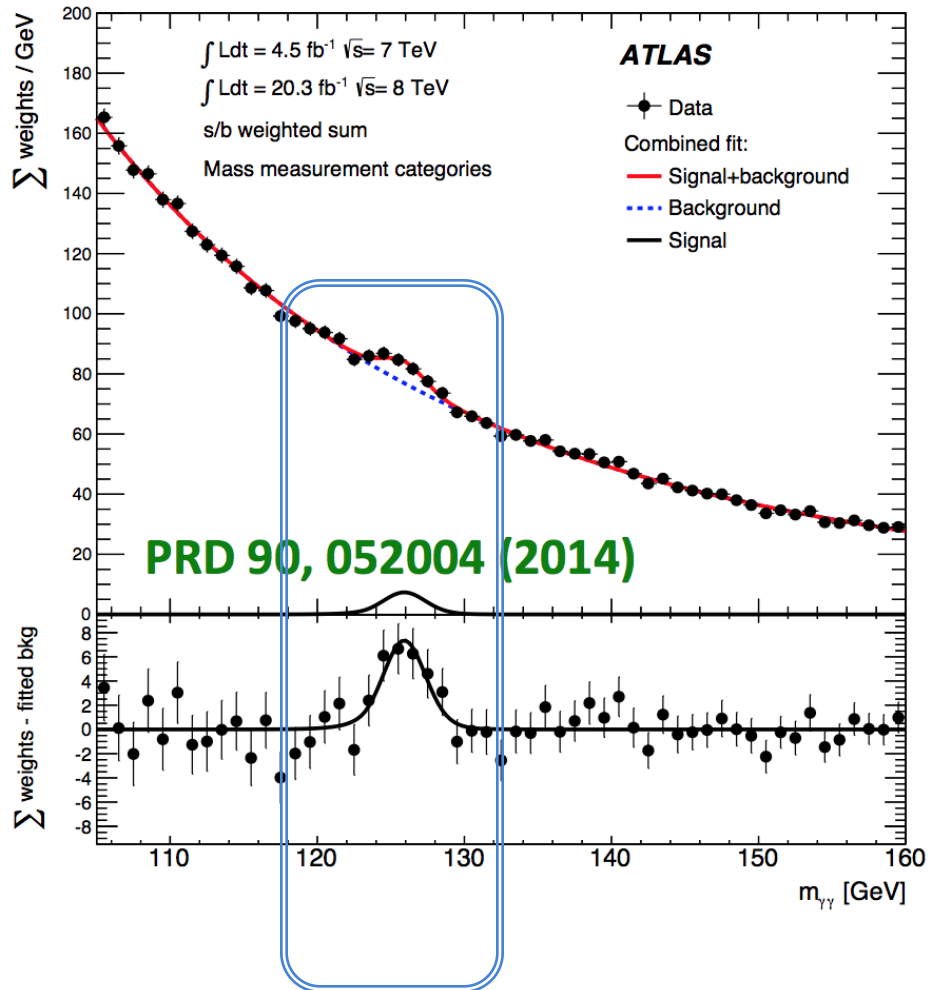

Combined LHC mass measurement

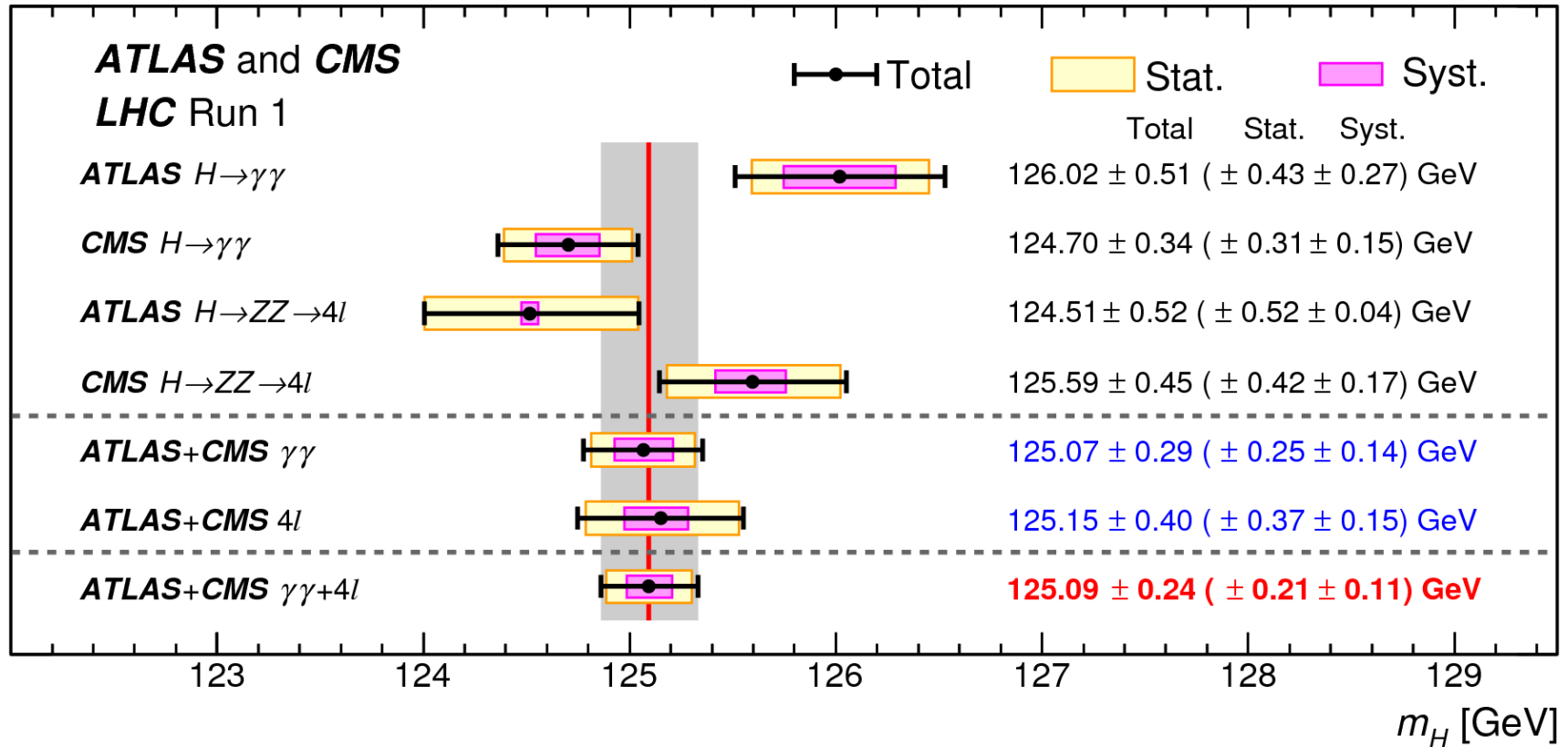



98

For the record

- ~5150 authors.
- Found that there are two:
 - Archana Sharma
(both CMS)
 - Andrea Bocci
 - Muhammad Ahmad
 - F. M. Giorgi
(one CMS, one ATLAS)



Physics paper sets record with more than 5,000 authors

Detector teams at the Large Hadron Collider collaborated for a more precise estimate of the size of the Higgs boson.

Daive Castelvechi

15 May 2015



CERN

Thousands of scientists and engineers have worked on the Large Hadron Collider at CERN.

A physics paper with 5,154 authors has — as far as anyone knows — broken the record for the largest number of contributors to a single research article.

Standard Model of Particle Physics



$$\begin{aligned}
 & -\frac{1}{2}\partial_\nu g_\mu^a \partial_\nu g_\mu^a - g_s f^{abc} \partial_\mu g_\nu^a g_\mu^b g_\nu^c - \frac{1}{4}g_s^2 f^{abc} f^{ade} g_\mu^b g_\nu^c g_\mu^d g_\nu^e + \frac{1}{2}ig_s^2 (\bar{q}_i^\sigma \gamma^\mu q_j^\sigma) g_\mu^a + \bar{G}^a \partial^2 G^a + g_s f^{abc} \partial_\mu \bar{G}^a G^b g_\mu^c - \\
 & \partial_\nu W_\mu^+ \partial_\nu W_\mu^- - M^2 W_\mu^+ W_\mu^- - \frac{1}{2}\partial_\nu Z_\mu^0 \partial_\nu Z_\mu^0 - \frac{1}{2c_w^2} M^2 Z_\mu^0 Z_\mu^0 - \frac{1}{2}\partial_\mu A_\nu \partial_\mu A_\nu - \frac{1}{2}\partial_\mu H \partial_\mu H - \frac{1}{2}m_h^2 H^2 - \partial_\mu \phi^+ \partial_\mu \phi^- - \\
 & M^2 \phi^+ \phi^- - \frac{1}{2}\partial_\mu \phi^0 \partial_\mu \phi^0 - \frac{1}{2c_w^2} M \phi^0 \phi^0 - \beta_h \left[\frac{2M^2}{g^2} + \frac{2M}{g} H + \frac{1}{2}(H^2 + \phi^0 \phi^0 + 2\phi^+ \phi^-) \right] + \frac{2M^4}{g^2} \alpha_h - igc_w [\partial_\nu Z_\mu^0 (W_\mu^+ W_\nu^- - \\
 & W_\nu^+ W_\mu^-) - Z_\nu^0 (W_\mu^+ \partial_\nu W_\mu^- - W_\mu^- \partial_\nu W_\mu^+) + Z_\mu^0 (W_\nu^+ \partial_\nu W_\mu^- - W_\nu^- \partial_\nu W_\mu^+)] - ig s_w [\partial_\nu A_\mu (W_\mu^+ W_\nu^- - W_\nu^+ W_\mu^-) - \\
 & A_\nu (W_\mu^+ \partial_\nu W_\mu^- - W_\mu^- \partial_\nu W_\mu^+) + A_\mu (W_\nu^+ \partial_\nu W_\mu^- - W_\nu^- \partial_\nu W_\mu^+)] - \frac{1}{2}g^2 W_\mu^+ W_\mu^- W_\nu^+ W_\nu^- + \frac{1}{2}g^2 W_\mu^+ W_\nu^- W_\mu^- W_\nu^+ + \\
 & g^2 c_w^2 (Z_\mu^0 W_\mu^+ Z_\nu^0 W_\nu^- - Z_\mu^0 Z_\nu^0 W_\mu^+ W_\nu^-) + g^2 s_w^2 (A_\mu W_\mu^+ A_\nu W_\nu^- - A_\mu A_\nu W_\mu^+ W_\nu^-) + g^2 s_w c_w [A_\mu Z_\nu^0 (W_\mu^+ W_\nu^- - \\
 & W_\nu^+ W_\mu^-) - 2A_\mu Z_\mu^0 W_\nu^+ W_\nu^-] - g\alpha [H^3 + H\phi^0 \phi^0 + 2H\phi^+ \phi^-] - \frac{1}{8}g^2 \alpha_h [H^4 + (\phi^0)^4 + 4(\phi^+ \phi^-)^2 + 4(\phi^0)^2 \phi^+ \phi^- + \\
 & 4H^2 \phi^+ \phi^- + 2(\phi^0)^2 H^2] - gM W_\mu^+ W_\mu^- H - \frac{1}{2}g \frac{M}{c_w^2} Z_\mu^0 Z_\mu^0 H - \frac{1}{2}ig [W_\mu^+ (\phi^0 \partial_\mu \phi^- - \phi^- \partial_\mu \phi^0) - W_\mu^- (\phi^0 \partial_\mu \phi^+ - \phi^+ \partial_\mu \phi^0)] + \\
 & \frac{1}{2}g [W_\mu^+ (H \partial_\mu \phi^- - \phi^- \partial_\mu H) - W_\mu^- (H \partial_\mu \phi^+ - \phi^+ \partial_\mu H)] + \frac{1}{2}g \frac{1}{c_w} (Z_\mu^0 (H \partial_\mu \phi^0 - \phi^0 \partial_\mu H) - ig \frac{s_w^2}{c_w} M Z_\mu^0 (W_\mu^+ \phi^- - \\
 & W_\mu^- \phi^+) + ig s_w M A_\mu (W_\mu^+ \phi^- - W_\mu^- \phi^+) - ig \frac{1-2c_w^2}{2c_w} Z_\mu^0 (\phi^+ \partial_\mu \phi^- - \phi^- \partial_\mu \phi^+) + ig s_w A_\mu (\phi^+ \partial_\mu \phi^- - \phi^- \partial_\mu \phi^+) - \\
 & \frac{1}{4}g^2 W_\mu^+ W_\mu^- [H^2 + (\phi^0)^2 + 2\phi^+ \phi^-] - \frac{1}{4}g^2 \frac{1}{c_w^2} Z_\mu^0 Z_\mu^0 [H^2 + (\phi^0)^2 + 2(2s_w^2 - 1)^2 \phi^+ \phi^-] - \frac{1}{2}g^2 \frac{s_w^2}{c_w} Z_\mu^0 \phi^0 (W_\mu^+ \phi^- + \\
 & W_\mu^- \phi^+) - \frac{1}{2}ig^2 \frac{s_w^2}{c_w} Z_\mu^0 H (W_\mu^+ \phi^- - W_\mu^- \phi^+) + \frac{1}{2}g^2 s_w A_\mu \phi^0 (W_\mu^+ \phi^- + W_\mu^- \phi^+) + \frac{1}{2}ig^2 s_w A_\mu H (W_\mu^+ \phi^- - W_\mu^- \phi^+) - \\
 & g^2 \frac{s_w}{c_w} (2c_w^2 - 1) Z_\mu^0 A_\mu \phi^+ \phi^- - g^1 s_w^2 A_\mu A_\mu \phi^+ \phi^- - \bar{e}^\lambda (\gamma \partial + m_e^\lambda) e^\lambda - \bar{\nu}^\lambda \gamma \partial \nu^\lambda - \bar{u}_j^\lambda (\gamma \partial + m_u^\lambda) u_j^\lambda - \bar{d}_j^\lambda (\gamma \partial + m_d^\lambda) d_j^\lambda + \\
 & ig s_w A_\mu [-(\bar{e}^\lambda \gamma^\mu e^\lambda) + \frac{2}{3}(\bar{u}_j^\lambda \gamma^\mu u_j^\lambda) - \frac{1}{3}(\bar{d}_j^\lambda \gamma^\mu d_j^\lambda)] + \frac{ig}{4c_w} Z_\mu^0 [(\bar{\nu}^\lambda \gamma^\mu (1 + \gamma^5) \nu^\lambda) + (\bar{e}^\lambda \gamma^\mu (4s_w^2 - 1 - \gamma^5) e^\lambda) + (\bar{u}_j^\lambda \gamma^\mu (\frac{4}{3}s_w^2 - \\
 & 1 - \gamma^5) u_j^\lambda) + (\bar{d}_j^\lambda \gamma^\mu (1 - \frac{8}{3}s_w^2 - \gamma^5) d_j^\lambda)] + \frac{ig}{2\sqrt{2}} W_\mu^+ [(\bar{\nu}^\lambda \gamma^\mu (1 + \gamma^5) e^\lambda) + (\bar{u}_j^\lambda \gamma^\mu (1 + \gamma^5) C_{\lambda\kappa} d_j^\kappa)] + \frac{ig}{2\sqrt{2}} W_\mu^- [(\bar{e}^\lambda \gamma^\mu (1 + \\
 & \gamma^5) \nu^\lambda) + (\bar{d}_j^\kappa C_{\lambda\kappa}^\dagger \gamma^\mu (1 + \gamma^5) u_j^\lambda)] + \frac{ig}{2\sqrt{2}} \frac{m_e^\lambda}{M} [-\phi^+ (\bar{\nu}^\lambda (1 - \gamma^5) e^\lambda) + \phi^- (\bar{e}^\lambda (1 + \gamma^5) \nu^\lambda)] - \frac{g}{2} \frac{m_e^\lambda}{M} [H (\bar{e}^\lambda e^\lambda) + \\
 & i\phi^0 (\bar{e}^\lambda \gamma^5 e^\lambda)] + \frac{ig}{2M\sqrt{2}} \phi^+ [-m_d^\kappa (\bar{u}_j^\lambda C_{\lambda\kappa} (1 - \gamma^5) d_j^\kappa) + m_u^\lambda (\bar{u}_j^\lambda C_{\lambda\kappa} (1 + \gamma^5) d_j^\kappa) + \frac{ig}{2M\sqrt{2}} \phi^- [m_d^\lambda (\bar{d}_j^\lambda C_{\lambda\kappa}^\dagger (1 + \gamma^5) u_j^\kappa) - \\
 & m_u^\kappa (\bar{d}_j^\lambda C_{\lambda\kappa}^\dagger (1 - \gamma^5) u_j^\kappa) - \frac{g}{2} \frac{m_u^\lambda}{M} H (\bar{u}_j^\lambda u_j^\lambda) - \frac{g}{2} \frac{m_d^\lambda}{M} H (\bar{d}_j^\lambda d_j^\lambda) + \frac{ig}{2} \frac{m_u^\lambda}{M} \phi^0 (\bar{u}_j^\lambda \gamma^5 u_j^\lambda) - \frac{ig}{2} \frac{m_d^\lambda}{M} \phi^0 (\bar{d}_j^\lambda \gamma^5 d_j^\lambda) + \bar{X}^+ (\partial^2 - \\
 & M^2) X^+ + \bar{X}^- (\partial^2 - M^2) X^- + \bar{X}^0 (\partial^2 - \frac{M^2}{c_w^2}) X^0 + \bar{Y} \partial^2 Y + igc_w W_\mu^+ (\partial_\mu \bar{X}^0 X^- - \partial_\mu \bar{X}^+ X^0) + ig s_w W_\mu^+ (\partial_\mu \bar{Y} X^- - \\
 & \partial_\mu \bar{X}^+ Y) + igc_w W_\mu^- (\partial_\mu \bar{X}^- X^0 - \partial_\mu \bar{X}^0 X^+) + ig s_w W_\mu^- (\partial_\mu \bar{X}^- Y - \partial_\mu \bar{Y} X^+) + igc_w Z_\mu^0 (\partial_\mu \bar{X}^+ X^+ - \partial_\mu \bar{X}^- X^-) + \\
 & ig s_w A_\mu (\partial_\mu \bar{X}^+ X^+ - \partial_\mu \bar{X}^- X^-) - \frac{1}{2}gM [\bar{X}^+ X^+ H + \bar{X}^- X^- H + \frac{1}{c_w^2} \bar{X}^0 X^0 H] + \frac{1-2c_w^2}{2c_w} igM [\bar{X}^+ X^0 \phi^+ - \\
 & \bar{X}^- X^0 \phi^-] + \frac{1}{2c_w} igM [\bar{X}^0 X^- \phi^+ - \bar{X}^0 X^+ \phi^-] + igM s_w [\bar{X}^0 X^- \phi^+ - \bar{X}^0 X^+ \phi^-] + \frac{1}{2}igM [\bar{X}^+ X^+ \phi^0 - \bar{X}^- X^- \phi^0]
 \end{aligned}$$

Standard Theory of Particle Physics



$$\begin{aligned} & -\frac{1}{2}\partial_\nu g_\mu^a \partial_\nu g_\mu^a - g_s f^{abc} \partial_\mu g_\nu^a g_\mu^b g_\nu^c - \frac{1}{4}g_s^2 f^{abc} f^{ade} g_\mu^b g_\nu^c g_\mu^d g_\nu^e + \frac{1}{2}ig_s^2 (\bar{q}_i^\sigma \gamma^\mu q_j^\sigma) g_\mu^a + \bar{G}^a \partial^2 G^a + g_s f^{abc} \partial_\mu \bar{G}^a G^b g_\mu^c - \\ & \partial_\nu W_\mu^+ \partial_\nu W_\mu^- - M^2 W_\mu^+ W_\mu^- - \frac{1}{2}\partial_\nu Z_\mu^0 \partial_\nu Z_\mu^0 - \frac{1}{2c_w^2} M^2 Z_\mu^0 Z_\mu^0 - \frac{1}{2}\partial_\mu A_\nu \partial_\mu A_\nu - \frac{1}{2}\partial_\mu H \partial_\mu H - \frac{1}{2}m_h^2 H^2 - \partial_\mu \phi^+ \partial_\mu \phi^- - \\ & M^2 \phi^+ \phi^- - \frac{1}{2}\partial_\mu \phi^0 \partial_\mu \phi^0 - \frac{1}{2c_w^2} M \phi^0 \phi^0 - \beta_h \left[\frac{2M^2}{g^2} + \frac{2M}{g} H + \frac{1}{2}(H^2 + \phi^0 \phi^0 + 2\phi^+ \phi^-) \right] + \frac{2M^4}{g^2} \alpha_h - igc_w [\partial_\nu Z_\mu^0 (W_\mu^+ W_\nu^- - \\ & W_\nu^+ W_\mu^-) - Z_\nu^0 (W_\mu^+ \partial_\nu W_\mu^- - W_\mu^- \partial_\nu W_\mu^+) + Z_\mu^0 (W_\nu^+ \partial_\nu W_\mu^- - W_\nu^- \partial_\nu W_\mu^+)] - ig s_w [\partial_\nu A_\mu (W_\mu^+ W_\nu^- - W_\nu^+ W_\mu^-) - \\ & A_\nu (W_\mu^+ \partial_\nu W_\mu^- - W_\mu^- \partial_\nu W_\mu^+) + A_\mu (W_\nu^+ \partial_\nu W_\mu^- - W_\nu^- \partial_\nu W_\mu^+)] - \frac{1}{2}g^2 W_\mu^+ W_\mu^- W_\nu^+ W_\nu^- + \frac{1}{2}g^2 W_\mu^+ W_\nu^- W_\mu^- W_\nu^+ + \\ & g^2 c_w^2 (Z_\mu^0 W_\mu^+ Z_\nu^0 W_\nu^- - Z_\nu^0 Z_\mu^0 W_\nu^+ W_\nu^-) + g^2 s_w^2 (A_\mu W_\mu^+ A_\nu W_\nu^- - A_\mu A_\nu W_\mu^+ W_\nu^-) + g^2 s_w c_w [A_\mu Z_\nu^0 (W_\mu^+ W_\nu^- - \\ & W_\nu^+ W_\mu^-) - 2A_\mu Z_\mu^0 W_\nu^+ W_\nu^-] - g\alpha [H^3 + H\phi^0 \phi^0 + 2H\phi^+ \phi^- - \frac{1}{2}\alpha_h [H^4 + (\phi^0)^4 - 4(\phi^+ \phi^-)^2 + 4(\phi^0)^2 \phi^+ \phi^- + \\ & 4H^2 \phi^+ \phi^- + 2(\phi^0)^2 H^2] - gM W_\mu^+ W_\mu^- - \frac{1}{2}ig \frac{M}{c_w} Z_\mu^0 H - \frac{1}{2}ig \frac{M}{c_w} (\phi^+ \partial_\mu \phi^- - \phi^- \partial_\mu \phi^+) - W_\mu^- (\phi^0 \partial_\mu \phi^+ - \phi^+ \partial_\mu \phi^0)] + \\ & \frac{1}{2}g [W_\mu^+ (H \partial_\mu \phi^- - \phi^- \partial_\mu H) - W_\mu^- (H \partial_\mu \phi^+ - \phi^+ \partial_\mu H)] + \frac{1}{c_w} (Z_\mu^0 (H \partial_\mu \phi^0 - \phi^0 \partial_\mu H) - ig \frac{s_w^2}{c_w} M Z_\mu^0 (W_\mu^+ \phi^- - \\ & W_\mu^- \phi^+)) + ig s_w A_\mu (W_\mu^+ \phi^- - W_\mu^- \phi^+) - g \frac{2c_w^2}{2c_w} Z_\mu^0 (\phi^+ \partial_\mu \phi^- - \phi^- \partial_\mu \phi^+) + ig s_w A_\mu (\phi^+ \partial_\mu \phi^- - \phi^- \partial_\mu \phi^+) - \\ & \frac{1}{4}g^2 (W_\mu^+ W_\mu^-)^2 + (\phi^0)^2 + 2\phi^+ \phi^- - \frac{1}{4}g^2 \frac{1}{c_w} Z_\mu^0 Z_\mu^0 [H^2 + (\phi^0)^2 + 2(2s_w^2 - 1)^2 \phi^+ \phi^-] - \frac{1}{2}g^2 \frac{s_w^2}{c_w} Z_\mu^0 \phi^0 (W_\mu^+ \phi^- + \\ & W_\mu^- \phi^+) - \frac{1}{2}ig^2 \frac{s_w^2}{c_w} Z_\mu^0 H (W_\mu^+ \phi^- - W_\mu^- \phi^+) + \frac{1}{2}g^2 s_w A_\mu (W_\mu^+ \phi^- - W_\mu^- \phi^+) + g^2 s_w^2 W_\mu^+ H (W_\mu^+ \phi^- - W_\mu^- \phi^+) - \\ & g^2 \frac{s_w}{c_w} (2c_w^2 - 1) Z_\mu^0 A_\mu \phi^+ \phi^- - g^1 s_w^2 A_\mu A_\mu \phi^+ \phi^- - \frac{1}{2}(\bar{u}_j^\lambda \gamma^\mu u_j^\lambda) (\gamma^\mu \partial + m_u^\lambda) u_j^\lambda - \frac{1}{2}(\bar{d}_j^\lambda \gamma^\mu d_j^\lambda) (\gamma^\mu \partial + m_d^\lambda) d_j^\lambda + \\ & ig s_w A_\mu [-(\bar{e}^\lambda \gamma^\mu e^\lambda) + \frac{2}{3}(\bar{u}_j^\lambda \gamma^\mu u_j^\lambda) - \frac{1}{3}(\bar{d}_j^\lambda \gamma^\mu d_j^\lambda) + Z_\mu^0 [(\bar{\nu}^\lambda \gamma^\mu (1 + \gamma^5) \nu^\lambda) + (\bar{e}^\lambda \gamma^\mu (4s_w^2 - 1 - \gamma^5) e^\lambda) + (\bar{u}_j^\lambda \gamma^\mu (\frac{4}{3}s_w^2 - \\ & 1 - \gamma^5) u_j^\lambda) + (\bar{d}_j^\lambda \gamma^\mu (-\frac{2}{3} + \gamma^5) d_j^\lambda) - \frac{1}{2\sqrt{2}} W_\mu^- [(\bar{\nu}^\lambda \gamma^\mu (1 + \gamma^5) e^\lambda) + (\bar{u}_j^\lambda \gamma^\mu (1 + \gamma^5) C_{\lambda\kappa} d_j^\kappa)] + \frac{ig}{2\sqrt{2}} W_\mu^- [(\bar{e}^\lambda \gamma^\mu (1 + \\ & \gamma^5) e^\lambda) + (\bar{u}_j^\lambda \gamma^\mu (1 + \gamma^5) u_j^\lambda)] + \frac{ig}{2\sqrt{2}} \frac{m_\lambda}{M} [-\phi^+ (\bar{\nu}^\lambda (1 - \gamma^5) e^\lambda) + \phi^- (\bar{e}^\lambda (1 + \gamma^5) \nu^\lambda)] - \frac{g}{2} \frac{m_\lambda^2}{M} [H (\bar{e}^\lambda e^\lambda) + \\ & i\phi^0 (\bar{e}^\lambda \gamma^5 e^\lambda)] + \frac{ig}{2M\sqrt{2}} \phi^+ [-m_d^\lambda (\bar{u}_j^\lambda C_{\lambda\kappa} (1 - \gamma^5) d_j^\kappa) + m_u^\lambda (\bar{u}_j^\lambda C_{\lambda\kappa} (1 + \gamma^5) d_j^\kappa) + \frac{ig}{2M\sqrt{2}} \phi^- [m_d^\lambda (\bar{d}_j^\lambda C_{\lambda\kappa}^\dagger (1 + \gamma^5) u_j^\kappa) - \\ & m_u^\lambda (\bar{d}_j^\lambda C_{\lambda\kappa}^\dagger (1 - \gamma^5) u_j^\kappa) - \frac{g}{2} \frac{m_\lambda^2}{M} H (\bar{u}_j^\lambda u_j^\lambda) - \frac{g}{2} \frac{m_\lambda^2}{M} H (\bar{d}_j^\lambda d_j^\lambda) + \frac{ig}{2} \frac{m_\lambda^2}{M} \phi^0 (\bar{u}_j^\lambda \gamma^5 u_j^\lambda) - \frac{ig}{2} \frac{m_\lambda^2}{M} \phi^0 (\bar{d}_j^\lambda \gamma^5 d_j^\lambda) + \bar{X}^+ (\partial^2 - \\ & M^2) X^+ + \bar{X}^- (\partial^2 - M^2) X^- + \bar{X}^0 (\partial^2 - \frac{M^2}{c_w^2}) X^0 + \bar{Y} \partial^2 Y + igc_w W_\mu^+ (\partial_\mu \bar{X}^0 X^- - \partial_\mu \bar{X}^+ X^0) + ig s_w W_\mu^+ (\partial_\mu \bar{Y} X^- - \\ & \partial_\mu \bar{X}^+ Y) + igc_w W_\mu^- (\partial_\mu \bar{X}^- X^0 - \partial_\mu \bar{X}^0 X^+) + ig s_w W_\mu^- (\partial_\mu \bar{X}^- Y - \partial_\mu \bar{Y} X^+) + igc_w Z_\mu^0 (\partial_\mu \bar{X}^+ X^+ - \partial_\mu \bar{X}^- X^-) + \\ & ig s_w A_\mu (\partial_\mu \bar{X}^+ X^+ - \partial_\mu \bar{X}^- X^-) - \frac{1}{2}gM [\bar{X}^+ X^+ H + \bar{X}^- X^- H + \frac{1}{c_w^2} \bar{X}^0 X^0 H] + \frac{1-2c_w^2}{2c_w} igM [\bar{X}^+ X^0 \phi^+ - \\ & \bar{X}^- X^0 \phi^-] + \frac{1}{2c_w} igM [\bar{X}^0 X^- \phi^+ - \bar{X}^0 X^+ \phi^-] + igM s_w [\bar{X}^0 X^- \phi^+ - \bar{X}^0 X^+ \phi^-] + \frac{1}{2}igM [\bar{X}^+ X^+ \phi^0 - \bar{X}^- X^- \phi^0] \end{aligned}$$

SM with H = Standard Theory

Standard Theory of Particle Physics



$$\begin{aligned}
 & -\frac{1}{2}\partial_\nu g_\mu^a \partial_\nu g_\mu^a - g_s f^{abc} \partial_\mu g_\nu^a g_\mu^b g_\nu^c - \frac{1}{4}g_s^2 f^{abc} f^{ade} g_\mu^b g_\nu^c g_\mu^d g_\nu^e + \frac{1}{2}ig_s^2 (\bar{q}_i^\sigma \gamma^\mu q_j^\sigma) g_\mu^a + \bar{G}^a \partial^2 G^a + g_s f^{abc} \partial_\mu \bar{G}^a G^b g_\mu^c - \\
 & \partial_\nu W_\mu^+ \partial_\nu W_\mu^- - M^2 W_\mu^+ W_\mu^- - \frac{1}{2}\partial_\nu Z_\mu^0 \partial_\nu Z_\mu^0 - \frac{1}{2c_w^2} M^2 Z_\mu^0 Z_\mu^0 - \frac{1}{2}\partial_\mu A_\nu \partial_\mu A_\nu - \frac{1}{2}\partial_\mu H \partial_\mu H - \frac{1}{2}m_h^2 H^2 - \partial_\mu \phi^+ \partial_\mu \phi^- - \\
 & M^2 \phi^+ \phi^- - \frac{1}{2}\partial_\mu \phi^0 \partial_\mu \phi^0 - \frac{1}{2c_w^2} M \phi^0 \phi^0 - \beta_h [\frac{2M^2}{g^2} + \frac{2M}{g} H + \frac{1}{2}(H^2 + \phi^0 \phi^0 + 2\phi^+ \phi^-)] + \frac{2M^4}{g^2} \alpha_h - igc_w [\partial_\nu Z_\mu^0 (W_\mu^+ W_\nu^- - \\
 & W_\nu^+ W_\mu^-) - Z_\nu^0 (W_\mu^+ \partial_\nu W_\mu^- - W_\mu^- \partial_\nu W_\mu^+) + Z_\mu^0 (W_\nu^+ \partial_\nu W_\mu^- - W_\nu^- \partial_\nu W_\mu^+)] - igs_w [\partial_\nu A_\mu (W_\mu^+ W_\nu^- - W_\nu^+ W_\mu^-) - \\
 & A_\nu (W_\mu^+ \partial_\nu W_\mu^- - W_\mu^- \partial_\nu W_\mu^+) + A_\mu (W_\nu^+ \partial_\nu W_\mu^- - W_\nu^- \partial_\nu W_\mu^+)] - \frac{1}{2}g^2 W_\mu^+ W_\mu^- W_\nu^+ W_\nu^- + \frac{1}{2}g^2 W_\mu^+ W_\nu^- W_\mu^- W_\nu^+ + \\
 & g^2 c_w^2 (Z_\mu^0 W_\mu^+ Z_\nu^0 W_\nu^- - Z_\mu^0 Z_\nu^0 W_\mu^+ W_\nu^-) + g^2 s_w^2 (A_\mu W_\mu^+ A_\nu W_\nu^- - A_\mu A_\nu W_\mu^+ W_\nu^-) + g^2 s_w c_w [A_\mu Z_\nu^0 (W_\mu^+ W_\nu^- - \\
 & W_\nu^+ W_\mu^-) - 2A_\mu Z_\mu^0 W_\nu^+ W_\nu^-] - g\alpha [H^3 + H\phi^0 \phi^0 + 2H\phi^+ \phi^-] - \frac{1}{8}g^2 \alpha_h [H^4 + (\phi^0)^4 + 4(\phi^+ \phi^-)^2 + 4(\phi^0)^2 \phi^+ \phi^- + \\
 & 4H^2 \phi^+ \phi^- + 2(\phi^0)^2 H^2] - gM W_\mu^+ W_\mu^- H - \frac{1}{2}g \frac{M}{c_w^2} Z_\mu^0 Z_\mu^0 H - \frac{1}{2}ig [W_\mu^+ (\phi^0 \partial_\mu \phi^- - \phi^- \partial_\mu \phi^0) - W_\mu^- (\phi^0 \partial_\mu \phi^+ - \phi^+ \partial_\mu \phi^0)] + \\
 & \frac{1}{2}g [W_\mu^+ (H \partial_\mu \phi^- - \phi^- \partial_\mu H) - W_\mu^- (H \partial_\mu \phi^+ - \phi^+ \partial_\mu H)] + \frac{1}{2}g \frac{1}{c_w} [Z_\mu^0 (H \partial_\mu \phi^0 - \phi^0 \partial_\mu H) - ig \frac{s_w^2}{c_w} M Z_\mu^0 (W_\mu^+ \phi^- - \\
 & W_\mu^- \phi^+) + igs_w \\
 & \frac{1}{4}g^2 W_\mu^+ W_\mu^- [H \\
 & W_\mu^- \phi^+) - \frac{1}{2}ig^2 \frac{s_w^2}{c_w} Z_\mu^0 H (W_\mu^+ \phi^- - W_\mu^- \phi^+) + \frac{1}{2}g^2 s_w A_\mu \phi^0 (W_\mu^+ \phi^- + W_\mu^- \phi^+) + \frac{1}{2}ig^2 s_w A_\mu H (W_\mu^+ \phi^- - W_\mu^- \phi^+) - \\
 & g^2 \frac{s_w}{c_w} (2c_w^2 - 1) Z_\mu^0 A_\mu \phi^+ \phi^- - g^1 s_w^2 A_\mu A_\mu \phi^+ \phi^- - \bar{e}^\lambda (\gamma \partial + m_e^\lambda) e^\lambda - \bar{\nu}^\lambda \gamma \partial \nu^\lambda - \bar{u}_j^\lambda (\gamma \partial + m_u^\lambda) u_j^\lambda - \bar{d}_j^\lambda (\gamma \partial + m_d^\lambda) d_j^\lambda + \\
 & igs_w A_\mu [-(\bar{e}^\lambda \gamma^\mu e^\lambda) + \frac{2}{3}(\bar{u}_j^\lambda \gamma^\mu u_j^\lambda) - \frac{1}{3}(\bar{d}_j^\lambda \gamma^\mu d_j^\lambda)] + \frac{ig}{4c_w} Z_\mu^0 [(\bar{\nu}^\lambda \gamma^\mu (1 + \gamma^5) \nu^\lambda) + (\bar{e}^\lambda \gamma^\mu (4s_w^2 - 1 - \gamma^5) e^\lambda) + (\bar{u}_j^\lambda \gamma^\mu (\frac{4}{3}s_w^2 - \\
 & 1 - \gamma^5) u_j^\lambda) + (\bar{d}_j^\lambda \gamma^\mu (1 - \frac{8}{3}s_w^2 - \gamma^5) d_j^\lambda)] + \frac{ig}{2\sqrt{2}} W_\mu^+ [(\bar{\nu}^\lambda \gamma^\mu (1 + \gamma^5) e^\lambda) + (\bar{u}_j^\lambda \gamma^\mu (1 + \gamma^5) C_{\lambda\kappa} d_j^\kappa)] + \frac{ig}{2\sqrt{2}} W_\mu^- [(\bar{e}^\lambda \gamma^\mu (1 + \\
 & \gamma^5) \nu^\lambda) + (\bar{d}_j^\kappa C_{\lambda\kappa}^\dagger \gamma^\mu (1 + \gamma^5) u_j^\lambda)] + \frac{ig}{2\sqrt{2}} \frac{m_\lambda^2}{M} [-\phi^+ (\bar{\nu}^\lambda (1 - \gamma^5) e^\lambda) + \phi^- (\bar{e}^\lambda (1 + \gamma^5) \nu^\lambda)] - \frac{g}{2} \frac{m_\lambda^2}{M} [H (\bar{e}^\lambda e^\lambda) + \\
 & i\phi^0 (\bar{e}^\lambda \gamma^5 e^\lambda)] + \frac{ig}{2M\sqrt{2}} \phi^+ [-m_d^\lambda (\bar{u}_j^\lambda C_{\lambda\kappa} (1 - \gamma^5) d_j^\kappa) + m_u^\lambda (\bar{u}_j^\lambda C_{\lambda\kappa} (1 + \gamma^5) d_j^\kappa)] + \frac{ig}{2M\sqrt{2}} \phi^- [m_d^\lambda (\bar{d}_j^\lambda C_{\lambda\kappa}^\dagger (1 + \gamma^5) u_j^\kappa) - \\
 & m_u^\lambda (\bar{d}_j^\lambda C_{\lambda\kappa}^\dagger (1 - \gamma^5) u_j^\kappa)] - \frac{g}{2} \frac{m_\lambda^2}{M} H (\bar{u}_j^\lambda u_j^\lambda) - \frac{g}{2} \frac{m_\lambda^2}{M} H (\bar{d}_j^\lambda d_j^\lambda) + \frac{ig}{2} \frac{m_\lambda^2}{M} \phi^0 (\bar{u}_j^\lambda \gamma^5 u_j^\lambda) - \frac{ig}{2} \frac{m_\lambda^2}{M} \phi^0 (\bar{d}_j^\lambda \gamma^5 d_j^\lambda) + \bar{X}^+ (\partial^2 - \\
 & M^2) X^+ + \bar{X}^- (\partial^2 - M^2) X^- + \bar{X}^0 (\partial^2 - \frac{M^2}{c_w^2}) X^0 + \bar{Y} \partial^2 Y + igc_w W_\mu^+ (\partial_\mu \bar{X}^0 X^- - \partial_\mu \bar{X}^+ X^0) + igs_w W_\mu^+ (\partial_\mu \bar{Y} X^- - \\
 & \partial_\mu \bar{X}^+ Y) + igc_w W_\mu^- (\partial_\mu \bar{X}^- X^0 - \partial_\mu \bar{X}^0 X^+) + igs_w W_\mu^- (\partial_\mu \bar{X}^- Y - \partial_\mu \bar{Y} X^+) + igc_w Z_\mu^0 (\partial_\mu \bar{X}^+ X^+ - \partial_\mu \bar{X}^- X^-) + \\
 & igs_w A_\mu (\partial_\mu \bar{X}^+ X^+ - \partial_\mu \bar{X}^- X^-) - \frac{1}{2}gM [\bar{X}^+ X^+ H + \bar{X}^- X^- H + \frac{1}{c_w^2} \bar{X}^0 X^0 H] + \frac{1-2c_w^2}{2c_w} igM [\bar{X}^+ X^0 \phi^+ - \\
 & \bar{X}^- X^0 \phi^-] + \frac{1}{2c_w} igM [\bar{X}^0 X^- \phi^+ - \bar{X}^0 X^+ \phi^-] + igM s_w [\bar{X}^0 X^- \phi^+ - \bar{X}^0 X^+ \phi^-] + \frac{1}{2}igM [\bar{X}^+ X^+ \phi^0 - \bar{X}^- X^- \phi^0]
 \end{aligned}$$

Valid up to \sim Planck scale ?

The fate/character of the Universe

102

[JHEP 08 (2012) 098]

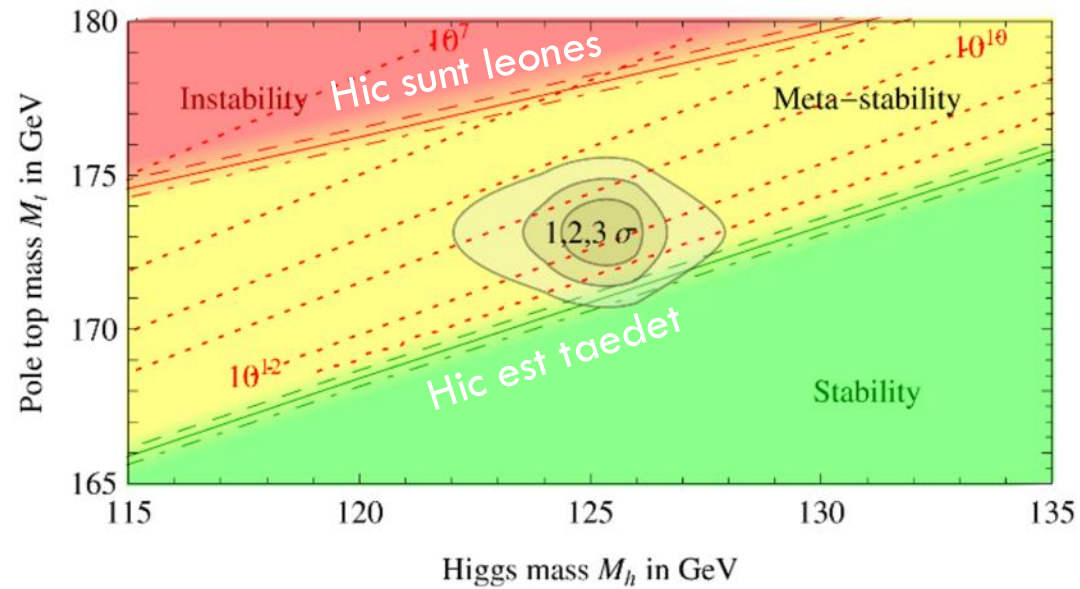
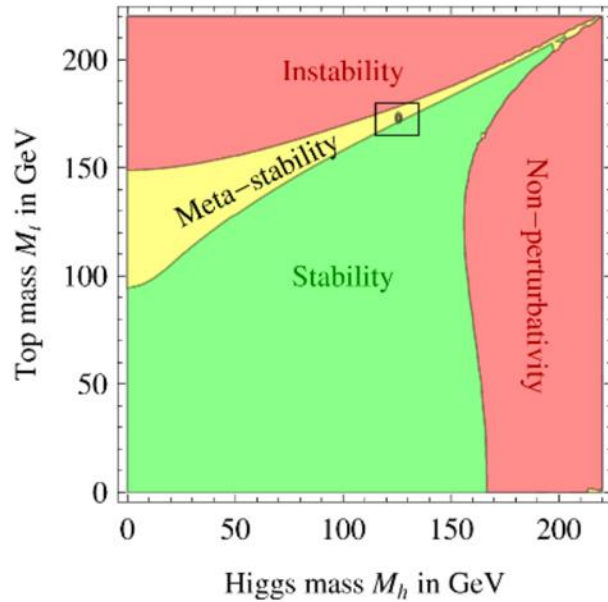

- The SM vacuum stability depends crucially on the masses of the top quark and Higgs boson.

Standard Theory of Particle Physics



$$\begin{aligned}
 & -\frac{1}{2}\partial_\nu g_\mu^a \partial_\nu g_\mu^a - g_s f^{abc} \partial_\mu g_\nu^a g_\mu^b g_\nu^c - \frac{1}{4}g_s^2 f^{abc} f^{ade} g_\mu^b g_\nu^c g_\mu^d g_\nu^e + \frac{1}{2}ig_s^2 (\bar{q}_i^\sigma \gamma^\mu q_j^\sigma) g_\mu^a + \bar{G}^a \partial^2 G^a + g_s f^{abc} \partial_\mu \bar{G}^a G^b g_\mu^c - \\
 & \partial_\nu W_\mu^+ \partial_\nu W_\mu^- - M^2 W_\mu^+ W_\mu^- - \frac{1}{2}\partial_\nu Z_\mu^0 \partial_\nu Z_\mu^0 - \frac{1}{2c_w^2} M^2 Z_\mu^0 Z_\mu^0 - \frac{1}{2}\partial_\mu A_\nu \partial_\mu A_\nu - \frac{1}{2}\partial_\mu H \partial_\mu H - \frac{1}{2}m_h^2 H^2 - \partial_\mu \phi^+ \partial_\mu \phi^- - \\
 & M^2 \phi^+ \phi^- - \frac{1}{2}\partial_\mu \phi^0 \partial_\mu \phi^0 - \frac{1}{2c_w^2} M \phi^0 \phi^0 - \beta_h [\frac{2M^2}{g^2} + \frac{2M}{g} H + \frac{1}{2}(H^2 + \phi^0 \phi^0 + 2\phi^+ \phi^-)] + \frac{2M^4}{g^2} \alpha_h - igc_w [\partial_\nu Z_\mu^0 (W_\mu^+ W_\nu^- - \\
 & W_\nu^+ W_\mu^-) - Z_\nu^0 (W_\mu^+ \partial_\nu W_\mu^- - W_\mu^- \partial_\nu W_\mu^+) + Z_\mu^0 (W_\nu^+ \partial_\nu W_\mu^- - W_\nu^- \partial_\nu W_\mu^+)] - ig s_w [\partial_\nu A_\mu (W_\mu^+ W_\nu^- - W_\nu^+ W_\mu^-) - \\
 & A_\nu (W_\mu^+ \partial_\nu W_\mu^- - W_\mu^- \partial_\nu W_\mu^+) + A_\mu (W_\nu^+ \partial_\nu W_\mu^- - W_\nu^- \partial_\nu W_\mu^+)] - \frac{1}{2}g^2 W_\mu^+ W_\mu^- W_\nu^+ W_\nu^- + \frac{1}{2}g^2 W_\mu^+ W_\nu^- W_\mu^- W_\nu^+ + \\
 & g^2 c_w^2 (Z_\mu^0 W_\mu^+ Z_\nu^0 W_\nu^- - Z_\mu^0 Z_\nu^0 W_\mu^+ W_\nu^-) + g^2 s_w^2 (A_\mu W_\mu^+ A_\nu W_\nu^- - A_\mu A_\nu W_\mu^+ W_\nu^-) + g^2 s_w c_w [A_\mu Z_\nu^0 (W_\mu^+ W_\nu^- - \\
 & W_\nu^+ W_\mu^-) - 2A_\mu Z_\mu^0 W_\nu^+ W_\nu^-] - g\alpha [H^3 + H\phi^0 \phi^0 + 2H\phi^+ \phi^-] - \frac{1}{8}g^2 \alpha_h [H^4 + (\phi^0)^4 + 4(\phi^+ \phi^-)^2 + 4(\phi^0)^2 \phi^+ \phi^- + \\
 & 4H^2 \phi^+ \phi^- + 2(\phi^0)^2 H^2] - g M W_\mu^+ W_\mu^- H - \frac{1}{2}g \frac{M}{c_w^2} Z_\mu^0 Z_\mu^0 H - \frac{1}{2}ig [W_\mu^+ (\phi^0 \partial_\mu \phi^- - \phi^- \partial_\mu \phi^0) - W_\mu^- (\phi^0 \partial_\mu \phi^+ - \phi^+ \partial_\mu \phi^0)] + \\
 & \frac{1}{2}g [W_\mu^+ (H \partial_\mu \phi^- - \phi^- \partial_\mu H) - W_\mu^- (H \partial_\mu \phi^+ - \phi^+ \partial_\mu H)] + \frac{1}{2}g \frac{1}{c_w} [Z_\mu^0 (H \partial_\mu \phi^0 - \phi^0 \partial_\mu H) - ig \frac{s_w^2}{c_w} M Z_\mu^0 (W_\mu^+ \phi^- - \\
 & W_\mu^- \phi^+) + ig s_w \\
 & \frac{1}{4}g^2 W_\mu^+ W_\mu^- [H \\
 & W_\mu^- \phi^+) - \frac{1}{2}ig^2 \frac{s_w^2}{c_w} Z_\mu^0 H (W_\mu^+ \phi^- - W_\mu^- \phi^+) + \frac{1}{2}g^2 s_w A_\mu \phi^0 (W_\mu^+ \phi^- + W_\mu^- \phi^+) + \frac{1}{2}ig^2 s_w A_\mu H (W_\mu^+ \phi^- - W_\mu^- \phi^+) - \\
 & g^2 \frac{s_w}{c_w} (2c_w^2 - 1) Z_\mu^0 A_\mu \phi^+ \phi^- - g^1 s_w^2 A_\mu A_\mu \phi^+ \phi^- - \bar{e}^\lambda (\gamma \partial + m_e^\lambda) e^\lambda - \bar{\nu}^\lambda \gamma \partial \nu^\lambda - \bar{u}_j^\lambda (\gamma \partial + m_u^\lambda) u_j^\lambda - \bar{d}_j^\lambda (\gamma \partial + m_d^\lambda) d_j^\lambda + \\
 & ig s_w A_\mu [-(\bar{e}^\lambda \gamma^\mu e^\lambda) + \frac{2}{3}(\bar{u}_j^\lambda \gamma^\mu u_j^\lambda) - \frac{1}{3}(\bar{d}_j^\lambda \gamma^\mu d_j^\lambda)] + \frac{ig}{4c_w} Z_\mu^0 [(\bar{\nu}^\lambda \gamma^\mu (1 + \gamma^5) \nu^\lambda) + (\bar{e}^\lambda \gamma^\mu (4s_w^2 - 1 - \gamma^5) e^\lambda) + (\bar{u}_j^\lambda \gamma^\mu (\frac{4}{3}s_w^2 - \\
 & 1 - \gamma^5) u_j^\lambda) + (\bar{d}_j^\lambda \gamma^\mu (1 - \frac{8}{3}s_w^2 - \gamma^5) d_j^\lambda)] + \frac{ig}{2\sqrt{2}} W_\mu^+ [(\bar{\nu}^\lambda \gamma^\mu (1 + \gamma^5) e^\lambda) + (\bar{u}_j^\lambda \gamma^\mu (1 + \gamma^5) C_{\lambda\kappa} d_j^\kappa)] + \frac{ig}{2\sqrt{2}} W_\mu^- [(\bar{e}^\lambda \gamma^\mu (1 + \\
 & \gamma^5) \nu^\lambda) + (\bar{d}_j^\kappa C_{\lambda\kappa}^\dagger \gamma^\mu (1 + \gamma^5) u_j^\lambda)] + \frac{ig}{2\sqrt{2}} \frac{m_\lambda^2}{M} [-\phi^+ (\bar{\nu}^\lambda (1 - \gamma^5) e^\lambda) + \phi^- (\bar{e}^\lambda (1 + \gamma^5) \nu^\lambda)] - \frac{g}{2} \frac{m_\lambda^2}{M} [H (\bar{e}^\lambda e^\lambda) + \\
 & i\phi^0 (\bar{e}^\lambda \gamma^5 e^\lambda)] + \frac{ig}{2M\sqrt{2}} \phi^+ [-m_d^\lambda (\bar{u}_j^\lambda C_{\lambda\kappa} (1 - \gamma^5) d_j^\kappa) + m_u^\lambda (\bar{u}_j^\lambda C_{\lambda\kappa} (1 + \gamma^5) d_j^\kappa)] + \frac{ig}{2M\sqrt{2}} \phi^- [m_d^\lambda (\bar{d}_j^\lambda C_{\lambda\kappa}^\dagger (1 + \gamma^5) u_j^\kappa) - \\
 & m_u^\lambda (\bar{d}_j^\lambda C_{\lambda\kappa}^\dagger (1 - \gamma^5) u_j^\kappa) - \frac{g}{2} \frac{m_\lambda^2}{M} H (\bar{u}_j^\lambda u_j^\lambda) - \frac{g}{2} \frac{m_\lambda^2}{M} H (\bar{d}_j^\lambda d_j^\lambda) + \frac{ig}{2} \frac{m_\lambda^2}{M} \phi^0 (\bar{u}_j^\lambda \gamma^5 u_j^\lambda) - \frac{ig}{2} \frac{m_\lambda^2}{M} \phi^0 (\bar{d}_j^\lambda \gamma^5 d_j^\lambda) + \bar{X}^+ (\partial^2 - \\
 & M^2) X^+ + \bar{X}^- (\partial^2 - M^2) X^- + \bar{X}^0 (\partial^2 - \frac{M^2}{c_w^2}) X^0 + \bar{Y} \partial^2 Y + igc_w W_\mu^+ (\partial_\mu \bar{X}^0 X^- - \partial_\mu \bar{X}^+ X^0) + ig s_w W_\mu^+ (\partial_\mu \bar{Y} X^- - \\
 & \partial_\mu \bar{X}^+ Y) + igc_w W_\mu^- (\partial_\mu \bar{X}^- X^0 - \partial_\mu \bar{X}^0 X^+) + ig s_w W_\mu^- (\partial_\mu \bar{X}^- Y - \partial_\mu \bar{Y} X^+) + igc_w Z_\mu^0 (\partial_\mu \bar{X}^+ X^+ - \partial_\mu \bar{X}^- X^-) + \\
 & ig s_w A_\mu (\partial_\mu \bar{X}^+ X^+ - \partial_\mu \bar{X}^- X^-) - \frac{1}{2}gM [\bar{X}^+ X^+ H + \bar{X}^- X^- H + \frac{1}{c_w^2} \bar{X}^0 X^0 H] + \frac{1-2c_w^2}{2c_w} igM [\bar{X}^+ X^0 \phi^+ - \\
 & \bar{X}^- X^0 \phi^-] + \frac{1}{2c_w} igM [\bar{X}^0 X^- \phi^+ - \bar{X}^0 X^+ \phi^-] + igM s_w [\bar{X}^0 X^- \phi^+ - \bar{X}^0 X^+ \phi^-] + \frac{1}{2}igM [\bar{X}^+ X^+ \phi^0 - \bar{X}^- X^- \phi^0]
 \end{aligned}$$

Valid up to ~Planck scale ?

Standard Theory of Particle Physics



$$\begin{aligned}
 & -\frac{1}{2}\partial_\nu g_\mu^a \partial_\nu g_\mu^a - g_s f^{abc} \partial_\mu g_\nu^a g_\mu^b g_\nu^c - \frac{1}{4}g_s^2 f^{abc} f^{ade} g_\mu^b g_\nu^c g_\mu^d g_\nu^e + \frac{1}{2}ig_s^2 (\bar{q}_i^\sigma \gamma^\mu q_j^\sigma) g_\mu^a + \bar{G}^a \partial^2 G^a + g_s f^{abc} \partial_\mu \bar{G}^a G^b g_\mu^c - \\
 & \partial_\nu W_\mu^+ \partial_\nu W_\mu^- - M^2 W_\mu^+ W_\mu^- - \frac{1}{2}\partial_\nu Z_\mu^0 \partial_\nu Z_\mu^0 - \frac{1}{2c_w^2} M^2 Z_\mu^0 Z_\mu^0 - \frac{1}{2}\partial_\mu A_\nu \partial_\mu A_\nu - \frac{1}{2}\partial_\mu H \partial_\mu H - \frac{1}{2}m_h^2 H^2 - \partial_\mu \phi^+ \partial_\mu \phi^- - \\
 & M^2 \phi^+ \phi^- - \frac{1}{2}\partial_\mu \phi^0 \partial_\mu \phi^0 - \frac{1}{2c_w^2} M \phi^0 \phi^0 - \beta_h \left[\frac{2M^2}{g^2} + \frac{2M}{g} H + \frac{1}{2}(H^2 + \phi^0 \phi^0 + 2\phi^+ \phi^-) \right] + \frac{2M^4}{g^2} \alpha_h - igc_w [\partial_\nu Z_\mu^0 (W_\mu^+ W_\nu^- - \\
 & W_\nu^+ W_\mu^-) - Z_\nu^0 (W_\mu^+ \partial_\nu W_\mu^- - W_\mu^- \partial_\nu W_\mu^+) + Z_\mu^0 (W_\nu^+ \partial_\nu W_\mu^- - W_\nu^- \partial_\nu W_\mu^+)] - ig s_w [\partial_\nu A_\mu (W_\mu^+ W_\nu^- - W_\nu^+ W_\mu^-) - \\
 & A_\nu (W_\mu^+ \partial_\nu W_\mu^- - W_\mu^- \partial_\nu W_\mu^+) + A_\mu (W_\nu^+ \partial_\nu W_\mu^- - W_\nu^- \partial_\nu W_\mu^+)] - \frac{1}{2}g^2 W_\mu^+ W_\mu^- W_\nu^+ W_\nu^- + \frac{1}{2}g^2 W_\mu^+ W_\nu^- W_\mu^- W_\nu^+ + \\
 & g^2 c_w^2 (Z_\mu^0 W_\mu^+ Z_\nu^0 W_\nu^- - Z_\mu^0 Z_\nu^0 W_\mu^+ W_\nu^-) + g^2 s_w^2 (A_\mu W_\mu^+ A_\nu W_\nu^- - A_\mu A_\nu W_\mu^+ W_\nu^-) + g^2 s_w c_w [A_\mu Z_\nu^0 (W_\mu^+ W_\nu^- - \\
 & W_\nu^+ W_\mu^-) - 2A_\mu Z_\mu^0 W_\nu^+ W_\nu^-] - g\alpha [H^3 + H\phi^0 \phi^0 + 2H\phi^+ \phi^-] - \frac{1}{8}g^2 \alpha_h [H^4 + (\phi^0)^4 + 4(\phi^+ \phi^-)^2 + 4(\phi^0)^2 \phi^+ \phi^- + \\
 & 4H^2 \phi^+ \phi^- + 2(\phi^0)^2 H^2] - g M W_\mu^+ W_\mu^- H - \frac{1}{2}g \frac{M}{c_w^2} Z_\mu^0 Z_\mu^0 H - \frac{1}{2}ig [W_\mu^+ (\phi^0 \partial_\mu \phi^- - \phi^- \partial_\mu \phi^0) - W_\mu^- (\phi^0 \partial_\mu \phi^+ - \phi^+ \partial_\mu \phi^0)] + \\
 & \frac{1}{2}g [W_\mu^+ (H \partial_\mu \phi^- - \phi^- \partial_\mu H) - W_\mu^- (H \partial_\mu \phi^+ - \phi^+ \partial_\mu H)] + \frac{1}{2}g \frac{1}{c_w} (Z_\mu^0 (H \partial_\mu \phi^0 - \phi^0 \partial_\mu H) - ig \frac{s_w^2}{c_w} M Z_\mu^0 (W_\mu^+ \phi^- - \\
 & W_\mu^- \phi^+) + ig s_w \\
 & \frac{1}{4}g^2 W_\mu^+ W_\mu^- [H \\
 & W_\mu^- \phi^+) - \frac{1}{2}ig^2 \frac{s_w^2}{c_w} Z^0 H (W^+ \phi^- - W^- \phi^+) + \frac{1}{2}g^2 s_w A_\mu \phi^0 (W^+ \phi^- + W^- \phi^+) + \frac{1}{2}ig^2 s_w A_\mu H (W^+ \phi^- - W^- \phi^+) - \\
 & g^2 \frac{s_w}{c_w} (2c_w^2 - 1) Z_\mu^0 \\
 & ig s_w A_\mu [-(\bar{e}^\lambda \gamma^\mu e \\
 & 1 - \gamma^5) u_j^\lambda] + (d_j^\lambda \gamma^\mu (1 - \frac{2}{3}s_w^2 - \gamma^5) d_j^\lambda)] + \frac{2}{2\sqrt{2}} W_\mu^+ [(\bar{\nu}^\lambda \gamma^\mu (1 + \gamma^5) e^\lambda) + (u_j^\lambda \gamma^\mu (1 + \gamma^5) C_{\lambda\kappa} d_j^\kappa)] + \frac{2}{2\sqrt{2}} W_\mu^- [(e^\lambda \gamma^\mu (1 + \\
 & \gamma^5) \nu^\lambda) + (d_j^\kappa C_{\lambda\kappa}^\dagger \gamma^\mu (1 + \gamma^5) u_j^\lambda)] + \frac{ig}{2\sqrt{2}} \frac{m_\lambda^2}{M} [-\phi^+ (\bar{\nu}^\lambda (1 - \gamma^5) e^\lambda) + \phi^- (\bar{e}^\lambda (1 + \gamma^5) \nu^\lambda)] - \frac{g}{2} \frac{m_\lambda^2}{M} [H (\bar{e}^\lambda e^\lambda) + \\
 & i\phi^0 (\bar{e}^\lambda \gamma^5 e^\lambda)] + \frac{ig}{2M\sqrt{2}} \phi^+ [-m_d^\kappa (\bar{u}_j^\lambda C_{\lambda\kappa} (1 - \gamma^5) d_j^\kappa) + m_u^\lambda (\bar{u}_j^\lambda C_{\lambda\kappa} (1 + \gamma^5) d_j^\kappa)] + \frac{ig}{2M\sqrt{2}} \phi^- [m_d^\lambda (\bar{d}_j^\lambda C_{\lambda\kappa}^\dagger (1 + \gamma^5) u_j^\kappa) - \\
 & m_u^\kappa (\bar{d}_j^\lambda C_{\lambda\kappa}^\dagger (1 - \gamma^5) u_j^\kappa) - \frac{g}{2} \frac{m_\lambda^2}{M} H (\bar{u}_j^\lambda u_j^\lambda) - \frac{g}{2} \frac{m_\lambda^2}{M} H (\bar{d}_j^\lambda d_j^\lambda) + \frac{ig}{2} \frac{m_\lambda^2}{M} \phi^0 (\bar{u}_j^\lambda \gamma^5 u_j^\lambda) - \frac{ig}{2} \frac{m_\lambda^2}{M} \phi^0 (\bar{d}_j^\lambda \gamma^5 d_j^\lambda) + \bar{X}^+ (\partial^2 - \\
 & M^2) X^+ + \bar{X}^- (\partial^2 - M^2) X^- + \bar{X}^0 (\partial^2 - \frac{M^2}{c_w^2}) X^0 + \bar{Y} \partial^2 Y + igc_w W_\mu^+ (\partial_\mu \bar{X}^0 X^- - \partial_\mu \bar{X}^+ X^0) + ig s_w W_\mu^+ (\partial_\mu \bar{Y} X^- - \\
 & \partial_\mu \bar{X}^+ Y) + igc_w W_\mu^- (\partial_\mu \bar{X}^- X^0 - \partial_\mu \bar{X}^0 X^+) + ig s_w W_\mu^- (\partial_\mu \bar{X}^- Y - \partial_\mu \bar{Y} X^+) + igc_w Z_\mu^0 (\partial_\mu \bar{X}^+ X^+ - \partial_\mu \bar{X}^- X^-) + \\
 & ig s_w A_\mu (\partial_\mu \bar{X}^+ X^+ - \partial_\mu \bar{X}^- X^-) - \frac{1}{2}g M [\bar{X}^+ X^+ H + \bar{X}^- X^- H + \frac{1}{c_w^2} \bar{X}^0 X^0 H] + \frac{1-2c_w^2}{2c_w} ig M [\bar{X}^+ X^0 \phi^+ - \\
 & \bar{X}^- X^0 \phi^-] + \frac{1}{2c_w} ig M [\bar{X}^0 X^- \phi^+ - \bar{X}^0 X^+ \phi^-] + ig M s_w [\bar{X}^0 X^- \phi^+ - \bar{X}^0 X^+ \phi^-] + \frac{1}{2}ig M [\bar{X}^+ X^+ \phi^0 - \bar{X}^- X^- \phi^0]
 \end{aligned}$$

Valid up to ~Planck scale ?

But: dark matter, matter-antimatter, etc.

The Next Standard Model



Standard Theory

The Next Standard Model



Standard theory



Something else

Moving forward

["Lawrence of Arabia" idea from C. Grojean]

- We must examine this Higgs to the fullest extent !
 - ▣ It may be the only clue to leave the SM oasis and cross the desert.





Deeper into the rabbit hole

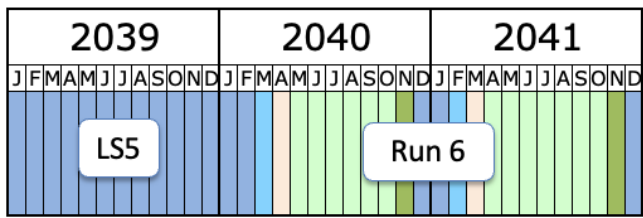
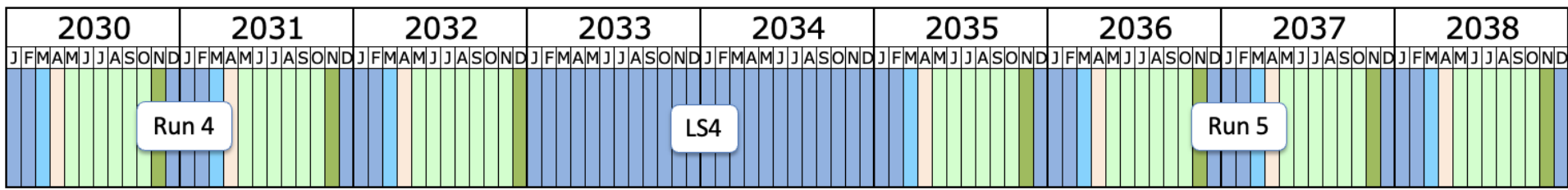
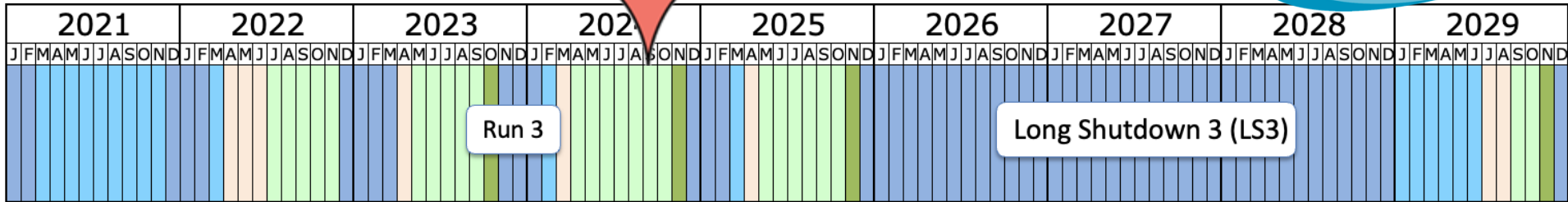

- Shutdown/Technical stop
- Protons physics
- Ions (tbc after LS4)
- Commissioning with beam
- Hardware commissioning

Sizing a Future Circular Collider

109

[<https://cds.cern.ch/record/2653532>]

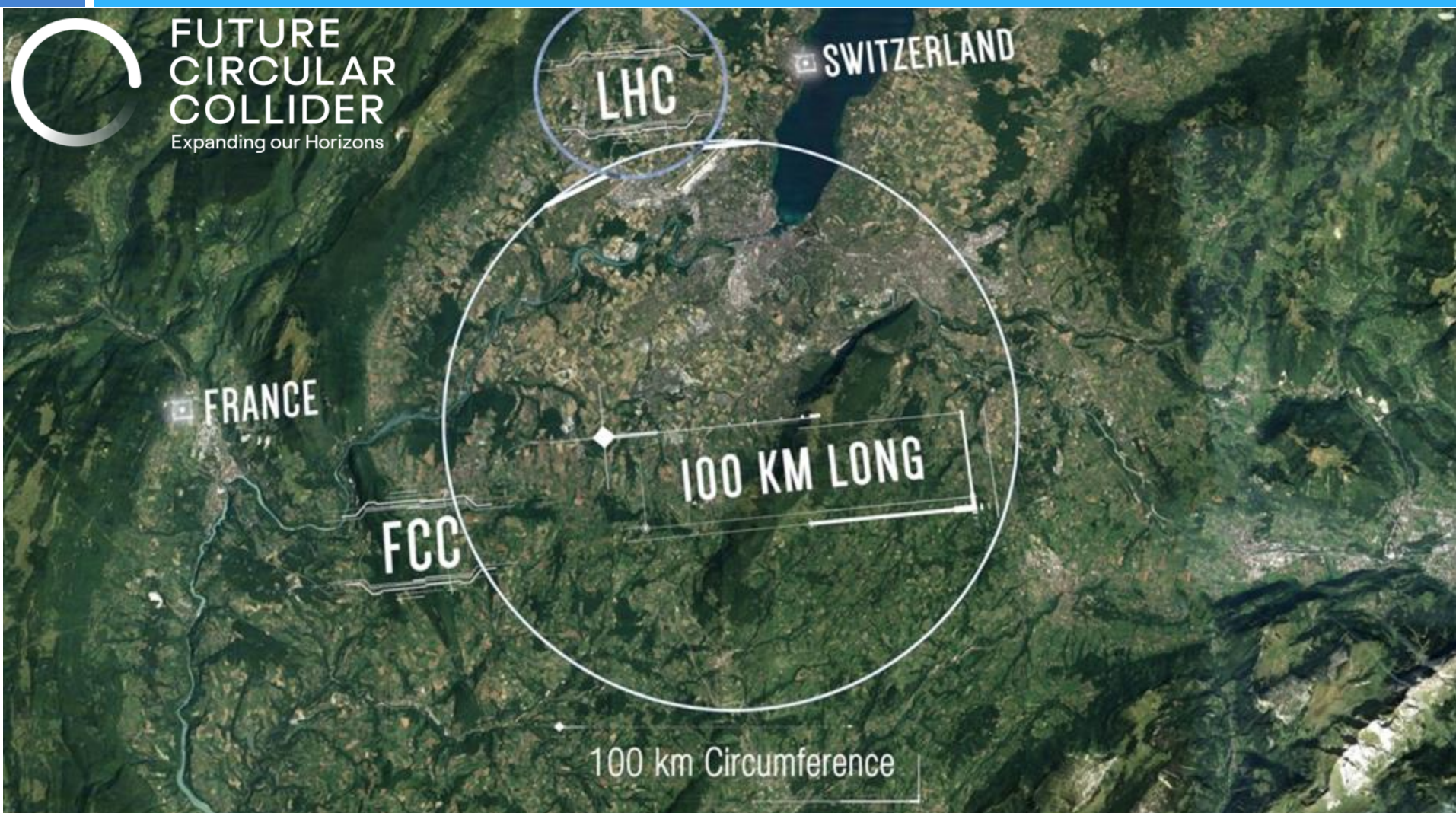

Sizing a Future Circular Collider

110

[<https://cds.cern.ch/record/2653532>]

FUTURE CIRCULAR COLLIDER
Expanding our Horizons

FRANCE SWITZERLAND

LHC

FCC

100 KM LONG

100 km Circumference

BBC NEWS
Science
Huge atom-smasher bid to find missing 95% of Universe

FINANCIAL TIMES
Science + Add to myFT
Cern chiefs push €16bn particle accelerator expansion plan
Debate over funding of 'pure science' ventures heats up with ambitious proposal for 91km supercollider

The Register
SCIENCE 63
CERN seeks €20B to build a bigger, faster, particle accelerator
The Future Circular Collider, if built, will be three times the size of the LHC
Tue 6 Feb 2024 07:29 UTC

CERN
Cern aims to build €20bn collider to unlock secrets of universe
Research lab submits plans for next-generation model at least three times size of Large Hadron Collider
Ian Sample Science editor
@iansample
Mon 5 Feb 2024 18:32 CET

Sizing a Future Circular Collider

111

[<https://cds.cern.ch/record/2653532>]



André David
@DrAndreDavid

Searching for the other 95% is no guarantee of finding them.

Two certainties remain:

- Without exploring we won't find even a smidgen of those 95%.
- Without pushing back the boundaries of technology, society won't benefit from that bonanza.



Huge atom-smasher bid to find missing 95% of Universe

From bbc.com



BBC NEWS

Science

Huge atom-smasher bid to find missing 95% of Universe



FINANCIAL TIMES

Science

Cern chiefs push €16bn particle accelerator expansion plan

Debate over funding of 'pure science' ventures heats up with ambitious proposal for 91km supercollider

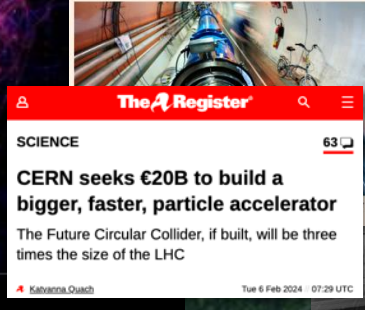

The Register

SCIENCE

CERN seeks €20B to build a bigger, faster, particle accelerator

The Future Circular Collider, if built, will be three times the size of the LHC

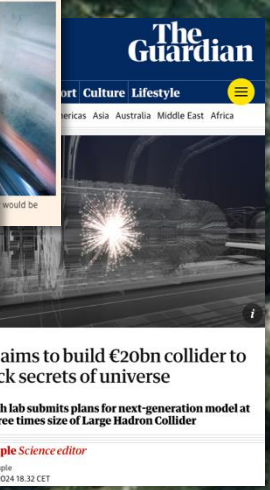

The Guardian

Cern aims to build €20bn collider to unlock secrets of universe

Research lab submits plans for next-generation model at least three times size of Large Hadron Collider

Ian Sample Science editor

The beautiful boring Universe today

- **Up above:**
“Simple six-parameter Λ CDM”.

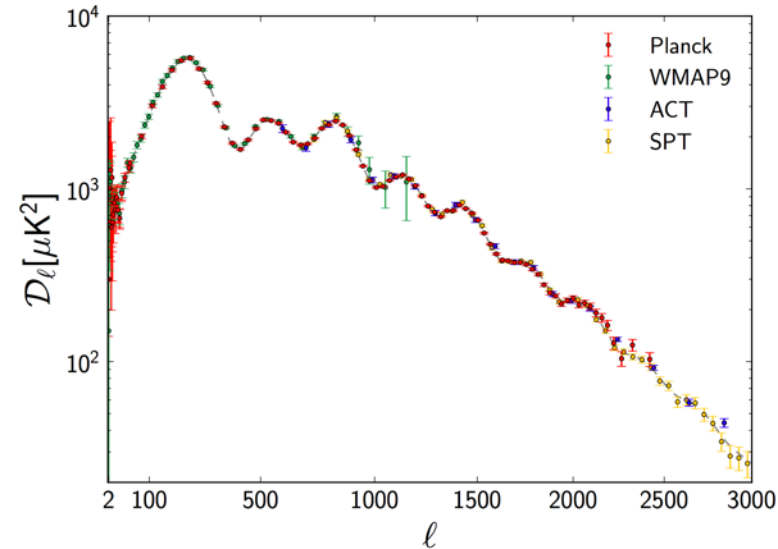

- **Down below:**
(Not-as-simple) ~ 20 -parameter Standard Model of Particle Physics.

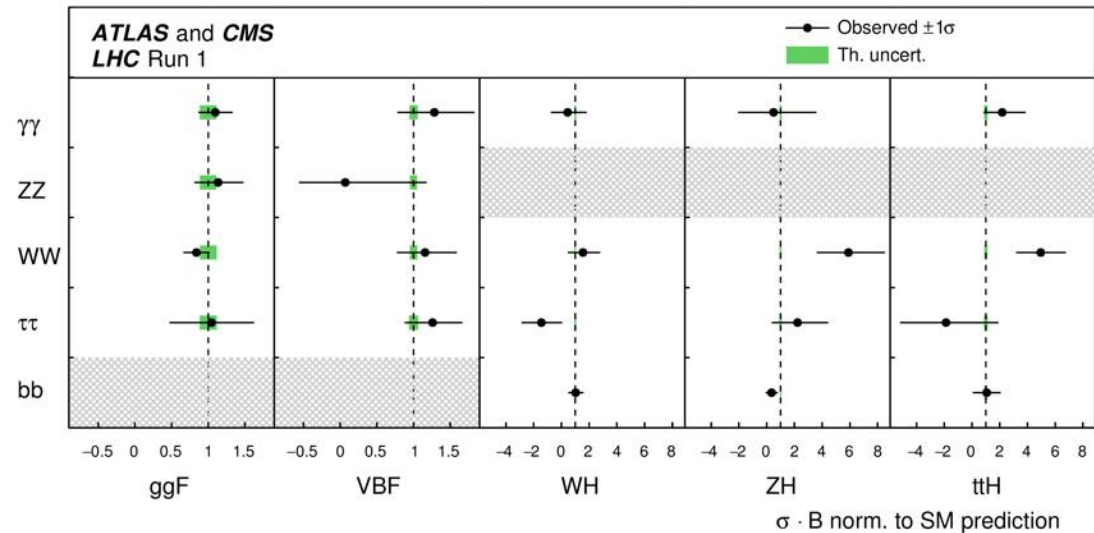

Looking forward to surprises at higher energy: PeV neutrinos, #MoarData at colliders, ...



TERMOS E CONDIÇÕES GERAIS DE UTILIZAÇÃO

- ❑ Não deixe perguntas por fazer. Seja crítico.
- ❑ Pensar mais pode fazer-lhe bem.
- ❑ Os resultados dependem de convicções e crenças pré-existentes. Agite-as antes de tirar conclusões.
- ❑ Mantenha-se aberto a outros pontos de vista.
- ❑ O conhecimento não gera infelicidade e pode ajudar a combatê-la.
- ❑ A ciência desilude quem não está alinhado com a realidade.
- ❑ Os presentes Termos e Condições são regidos e interpretados de acordo com o método científico.
- ❑ É competente o método experimental com exclusão de qualquer outro para dirimir quaisquer conflitos que resultem da interpretação e aplicação dos presentes Termos e Condições.

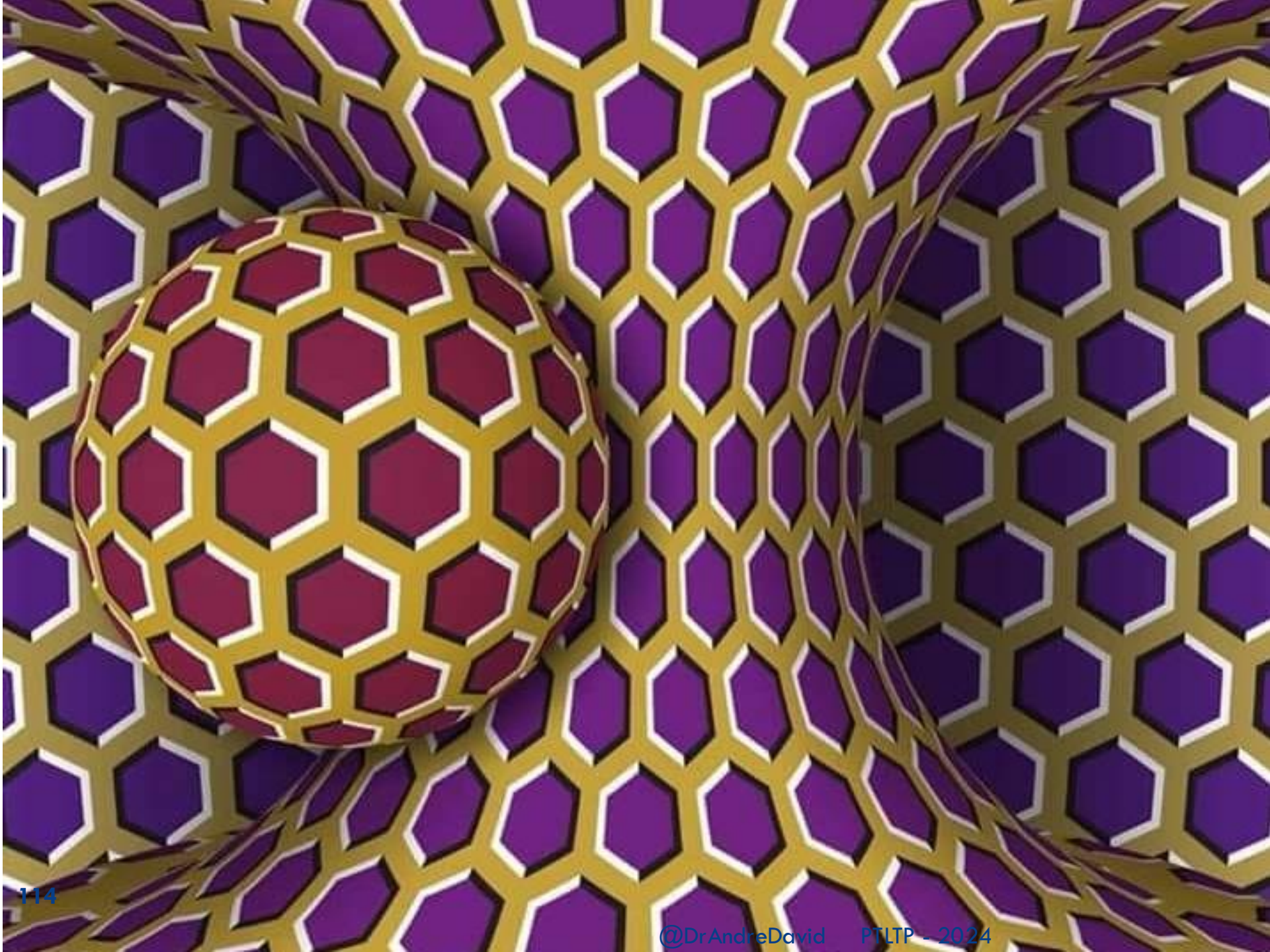



“...and references therein.”

- Experiments' pages on Higgs results:
 - ATLAS: <http://cern.ch/go/7IDT>
 - CMS: <http://cern.ch/go/6qmZ>
 - Tevatron: <http://cern.ch/go/h9jX>
 - CDF: <http://cern.ch/go/q8NV>
 - D0: <http://cern.ch/go/9Djq>