

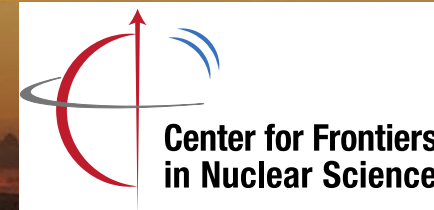

ACAT 2024



Science @ BNL and Stony Brook

22nd International Workshop on
Advanced Computing and Analysis Techniques in Physics Research

Wang Center @ Stony Brook University
March 11, 2024

Abhay Deshpande

Stony Brook University & Brookhaven National Laboratory



Stony Brook **University**





ACAT 2024

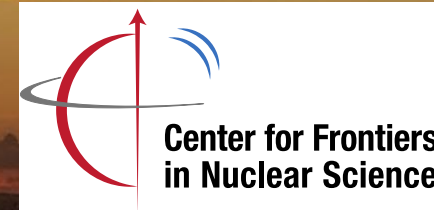

mainly Nuclear, Particle & Accelerator Science @ BNL and Stony Brook

22nd International Workshop on
Advanced Computing and Analysis Techniques in Physics Research

Wang Center @ Stony Brook University
March 11, 2024

Abhay Deshpande

Stony Brook University & Brookhaven National Laboratory



Stony Brook University





Many thanks to:

Alan Calder, Dmitri Denisov, Haiyan Gao, Robert Harrison,
John Hobbs who provided slides or information.

Stony Brook University

- Founded in 1957, Since 2001 member of Association of American Universities
- One of two SUNY Flagship Universities
 - 26k (17k UG) students, from 50 States and 150+ Countries
 - National Ranking #58
 - Public Universities #26; In NY:#1
 - National universities in social mobility #12
 - 200+ UG majors and minors, 48 Graduate Programs & Long Island's premier academic medical center – Dental, Health Technology Management, Medicine, Nursing and Social Welfare
- Regional Economic Impact:
 - \$7.23 Billion
 - \$470M tax revenue
 - 54,646 jobs (8% of Suffolk County) LI's largest single employer
 - 3% of the economic activity on Long Island
- Stony Brook & Battelle chair the Brookhaven Science Associates : Operate BNL: Columbia, Cornell, Harvard, MIT, Princeton and Yale

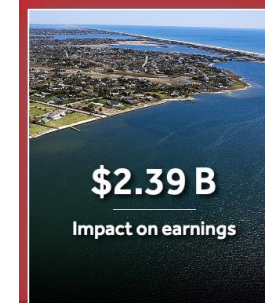

Brookhaven Lab: A Multi-purpose DOE Office of Science Lab

•Managed by Brookhaven Science Associates

- Partnership between Stony Brook University and Battelle Memorial Institute
- Core universities: Columbia, Cornell, Harvard, MIT, Princeton, Yale

•People

- 2,800 staff, 130 joint faculty, 500 students (FY22)
- 166 summer interns remotely; 189 in person (FY22)
- ~4,400 guests/users, including remote (FY22)
- >30,000 (K-12) students and educators annually (pre-COVID)
- 7 Nobel Prizes; 21 Laureates

Budget

- FY22 costs: \$704 million
- Strongly aligned to SC (86%) and to DOE (91%)

Regional Economic Impact

- Supports over 4,700 New York jobs
- ~\$400M NYS investment since 2013
- Long Island Rail-Road Station near Discovery Park



A Few of BNL's Employee Resource Groups

Stony Brook University

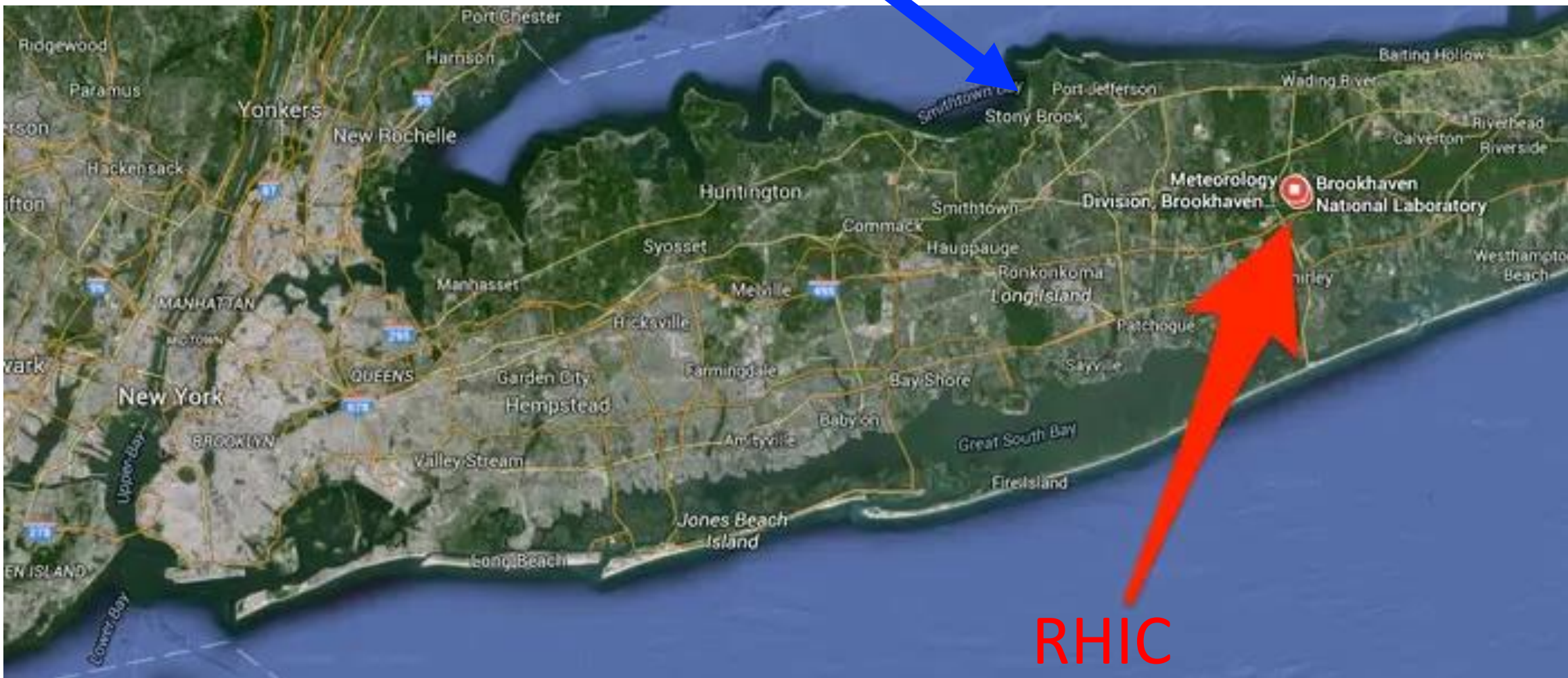

RHIC

Science Organizations at BNL

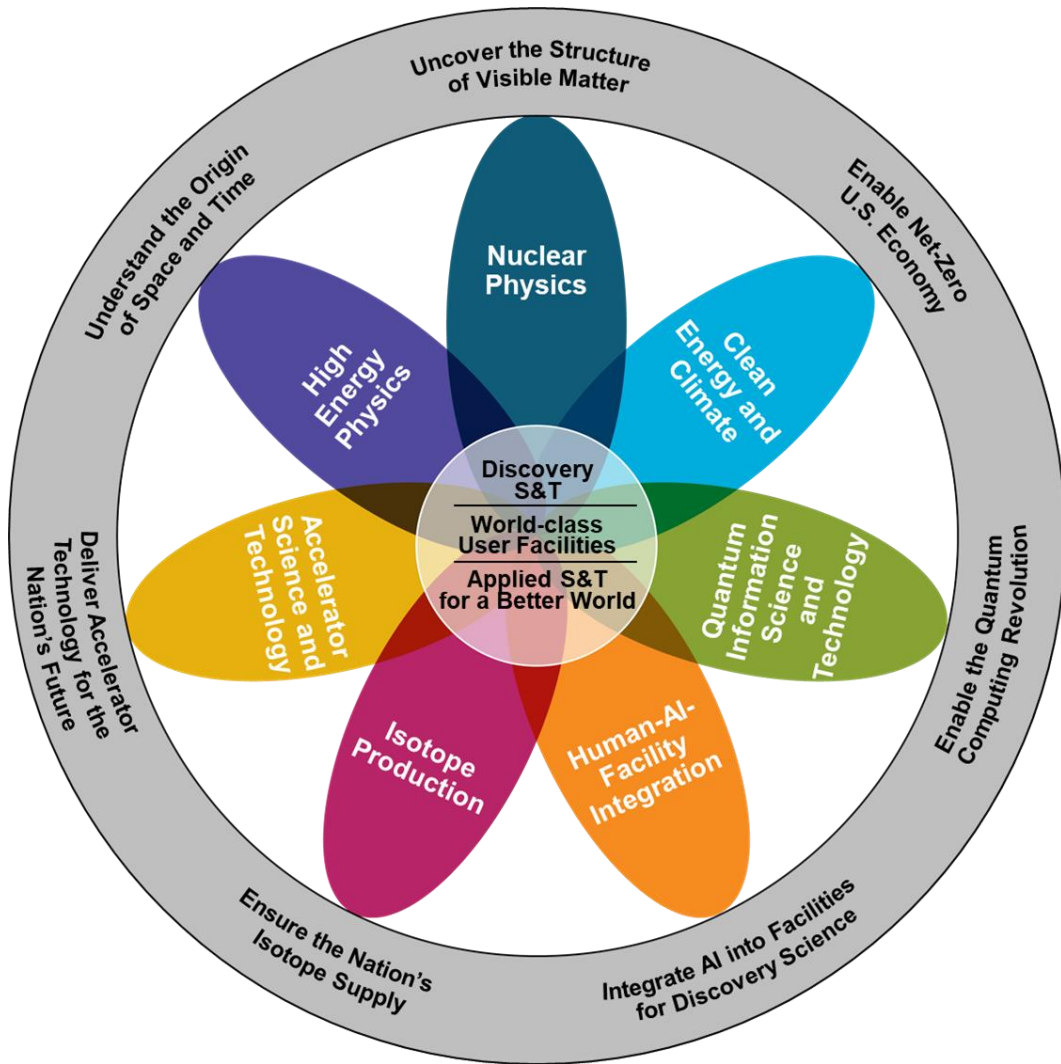

- Nuclear and Particle Physics
- Electron-Ion Collider
- Energy & Photon Sciences
- Environment, Biology, Nuclear Science & Nonproliferation
- Advanced Technology Research Office
- Computational Sciences Initiative

Significant collaboration/participation on all fronts: Stony Brook

Nuclear and Particle Physics at BNL

Our mission is to lead and support discovery-based, innovation-driven research at the frontiers of the subatomic world. We are **world-leading in nuclear physics research, building and operating accelerator-based user facilities** that serve international scientific communities. We also play a **leading role in global particle physics programs that push the limits of precision and expand our understanding of the cosmos**. Our pursuit of this fundamental and discovery research yields scientific and **technological breakthroughs, and applications that benefit society**—such as radioisotopes used to support industrial, medical and national security needs.

Our work draws on an international community filled with unique voices and perspectives, all contributing their ideas and experiences. We are passionate about welcoming people from all backgrounds and helping them succeed. Collectively, we will expand the boundaries of science and technology, advance the knowledge of humankind, bring new applications to society, and further our understanding of the natural world.

Nuclear & Particle Physics at BNL and Stony Brook

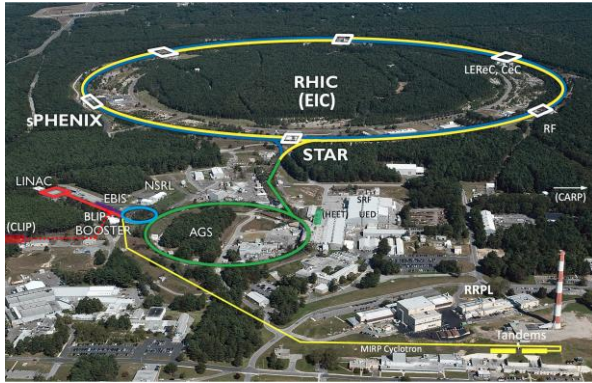

To understand sub-atomic world deeper and deeper

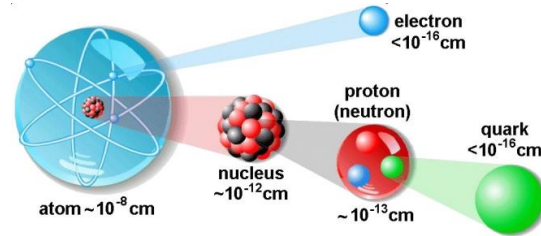

Electron-Ion Collider  Stony Brook University

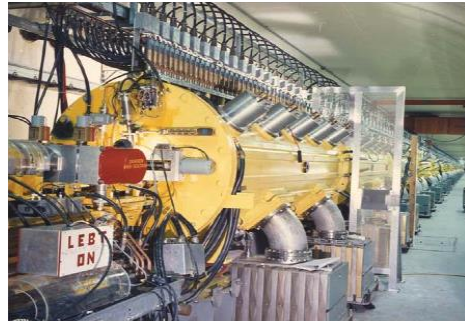
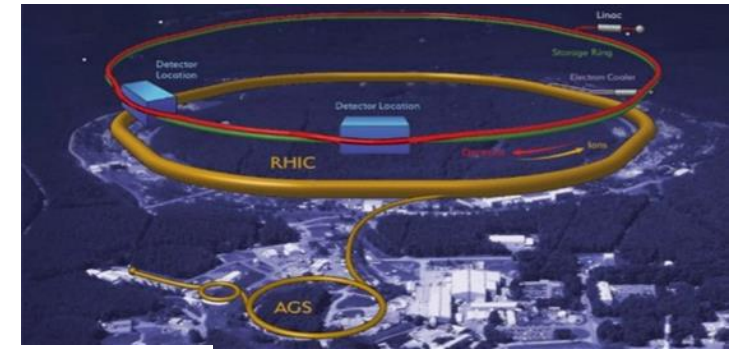

BLIP: Medical Isotopes

Develop unique technologies to answer fundamental questions in nature and for applications

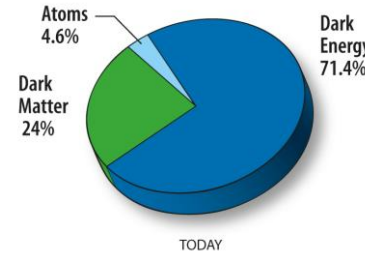

 Stony Brook University

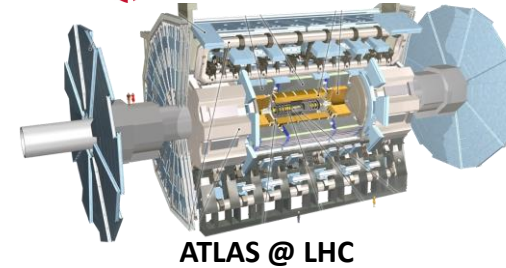

ATLAS @ LHC

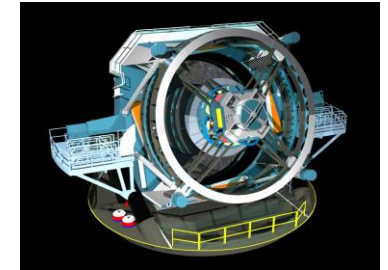

Ruben Observatory



NASA Space Radiation Lab

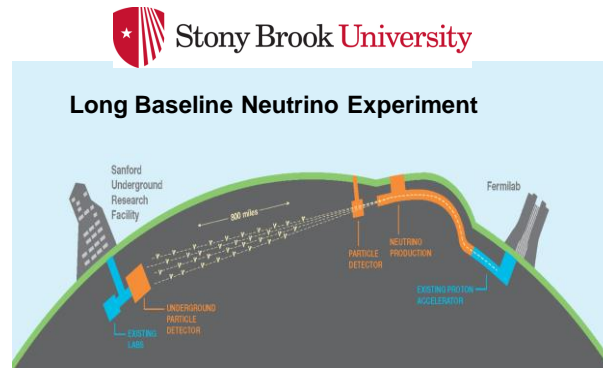

Long Baseline Neutrino Experiment

 Stony Brook University

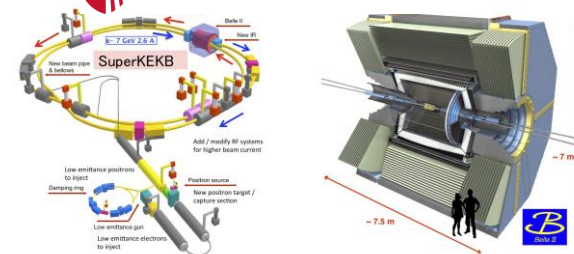

Belle II at SuperKEKB

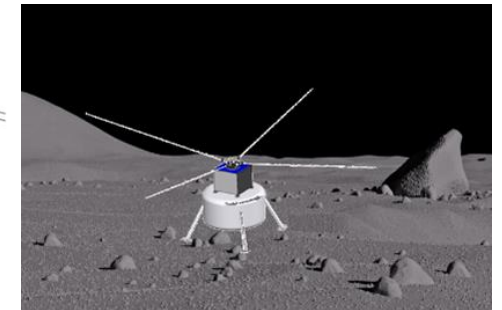

LuSEE-Night mission

Active high-energy and nuclear theory groups; RIKEN-BNL Research Center (RBRC) and **Center for Frontiers in Nuclear Science at Stony Brook**

Abhay Deshpande @ ACAT2024

- **ATLAS experiment at CERN**



- Lead laboratory for US ATLAS

- **Neutrino Program at Fermilab**



- Proto-DUNE detector with BNL-developed components
- Studying properties of neutrinos at short-baseline

- **Belle II experiment at KEK**

- Lead laboratory for US Belle II

- **Rubin Observatory**

- Commissioning the experiment in Chile



- **Theory, Detectors and Accelerators R&D**



- Major contributions to the field

ATLAS muon system at CERN

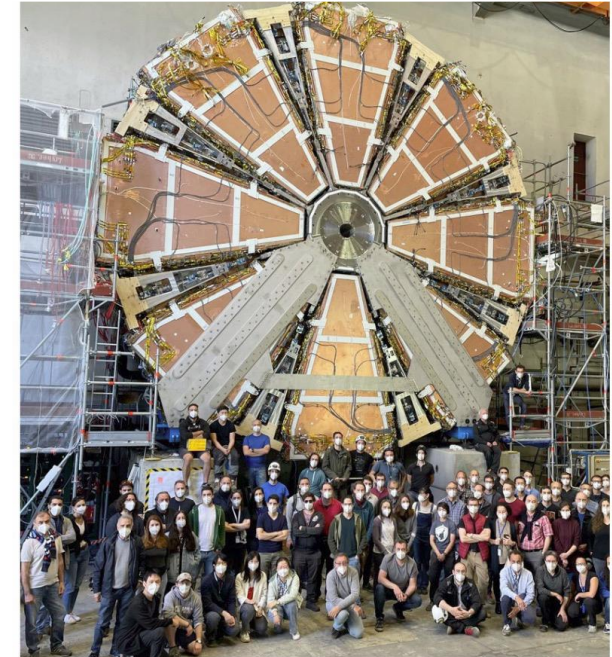

New g-2 Result

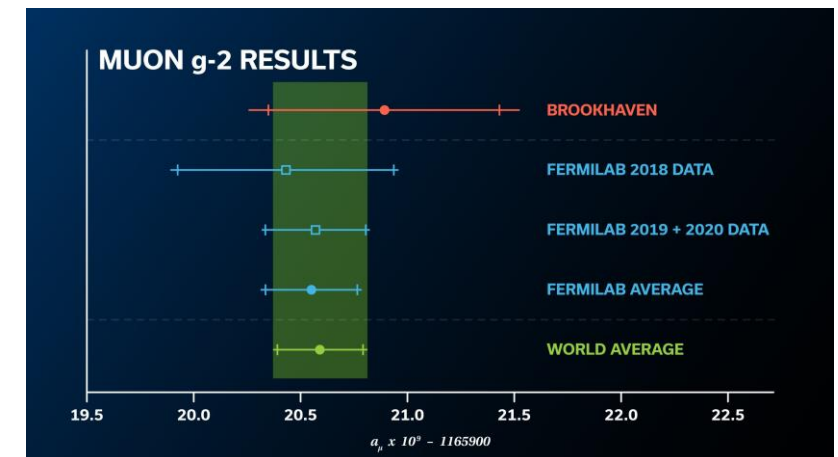



Developing Future of HEP Program

- **Energy Frontier**
 - Hosting project for \$300M HL-LHC ATLAS upgrade
 - Building magnets for the HL-LHC
 - Developing HL-LHC computing and software
- **Intensity Frontier**
 - Contributing to DUNE experiment
 - Leading DUNE far detector Module 2 activities
 - Preparing Belle II detector for Run II
- **Cosmic Frontier**
 - Getting ready to analyze Rubin Observatory data
 - Building LuSEE-Night mission to the far side of the moon
- **Leading Technologies Developments for Particle Physics**
 - Computing and software
 - Detectors and electronics
 - Accelerator R&D including superconducting magnets
- **Actively participating in developing long term future**

HL-LHC magnet testing at BNL



ATLAS silicon assembly at BNL



DUNE Module 2 design

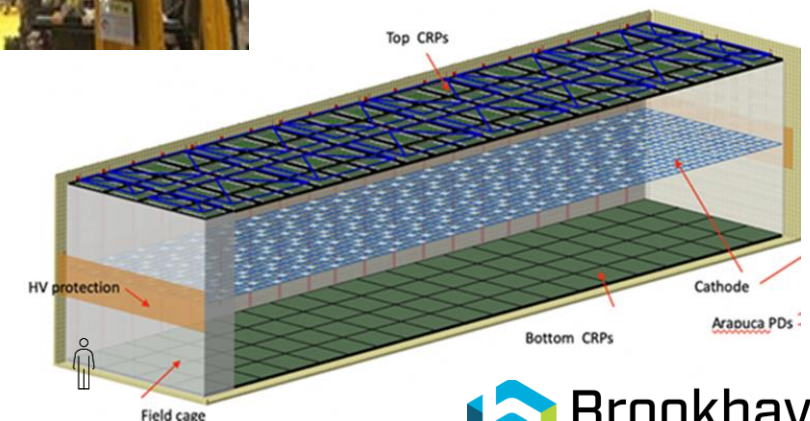

LHC and HL-LHC programs

- Energy frontier collider with 14 TeV center of mass energy
 - The only place to study the Higgs boson and many other elementary particles for ~20 years
 - x10 data set is yet to come
- HL-LHC brings unprecedented data challenge
 - Pushing accelerators, detectors and computing technologies
- Excellent training for early career scientists
 - Analysis, detectors, operations
- BNL and Particle Physics group at Stony Brook are fully committed to HL-LHC program success

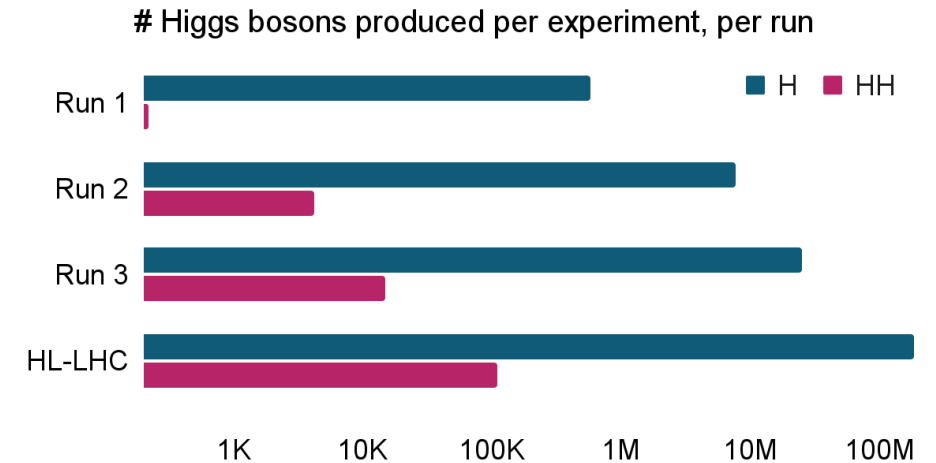

Magnet for HL-LHC



Intensity Frontier

- Timely construction of the DUNE experiment is the priority
 - Provides unprecedented potential for a wide range of scientific topics
 - BNL is committed to deliver Module 2; SBU engaged as collaborator
- Development of DUNE Phase II program is critical to pursue early implementation
 - BNL & SBU are actively engaged in physics and far detectors Modules 3 and 4 design
- Short baseline neutrino program provides important information about neutrinos and its interactions
 - Critical for DUNE success
- Studies of heavy quarks with Belle II
 - Puzzling anomalies remain

LBNF/DUNE

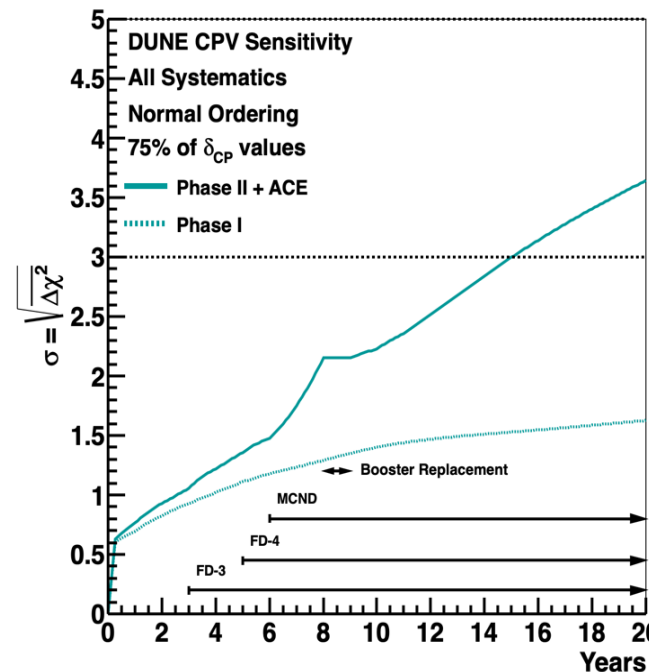
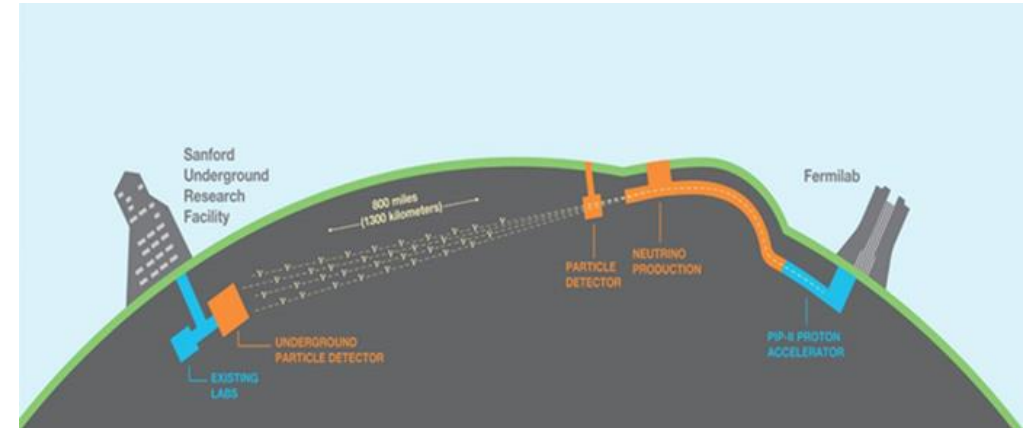

SuperKEKB Luminosity

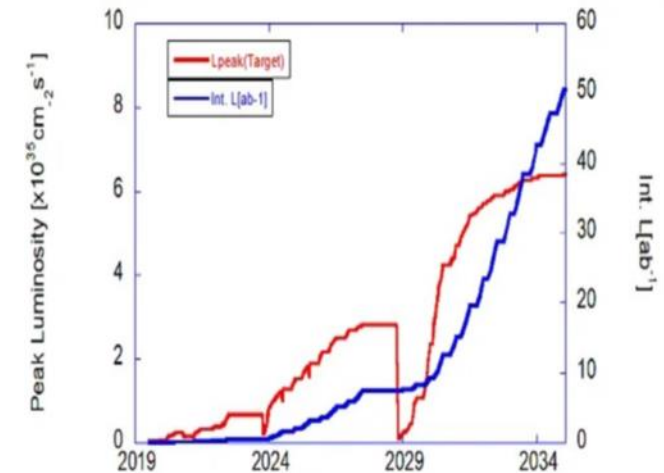

Cosmic Frontier

AT BNL:

- Commissioning and operations of Vera Rubin telescope in Chile
- Executing exciting opportunities for small scale experiments
 - BNL leads joint DOE/NASA LuSEE-Night program
- Developing plans for the next large-scale QIS based spectroscopic experiment

At Stony Brook:

- IceCube at the South Pole:
 - Studying the origins of the highest energy neutrinos and mapping of the neutrino sky (looks down into the earth)

Rubin Commissioning in Chile

 **Katrin Heitmann** 1:06 PM
Most amazing ending of the session! 😊 I was able to capture
Screen Shot 2022-02-22 at 2.02.33 PM.png



LuSEE-Night on the moon

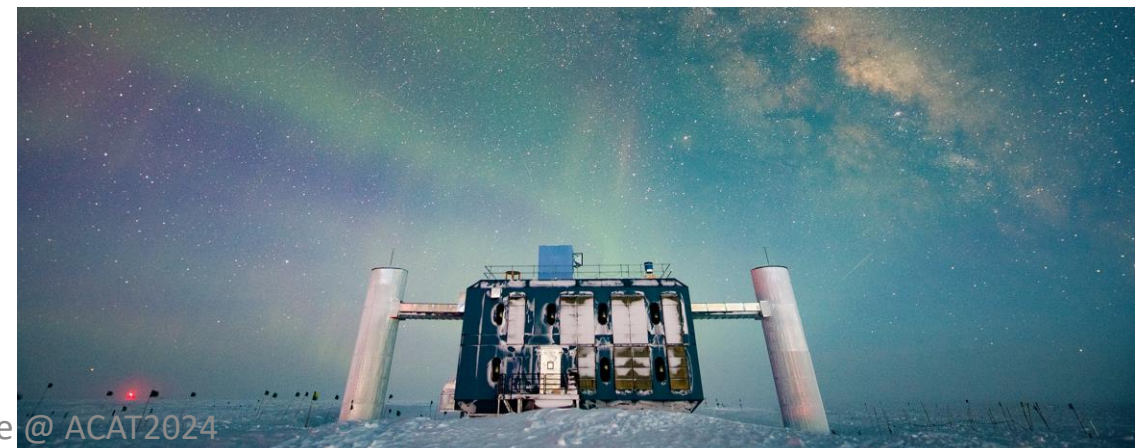
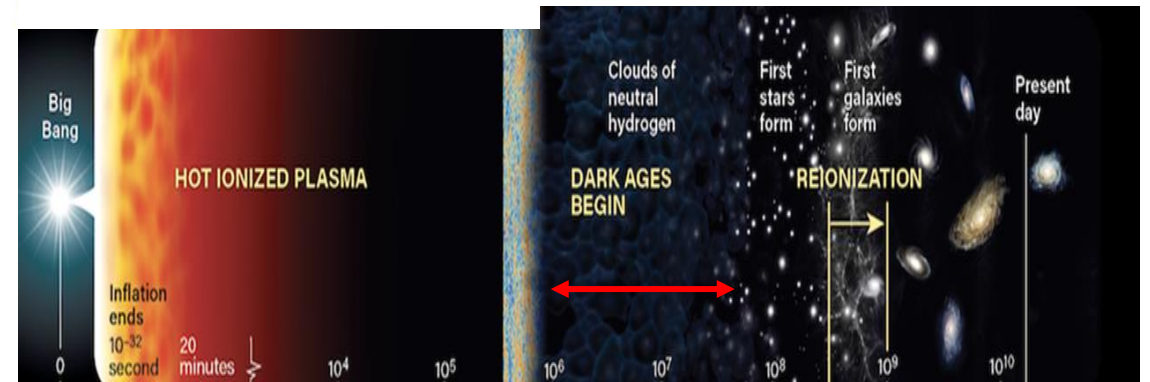

High Energy Theory at BNL

Strong connections with the C. N. Yang Center, the Simons Center for Physics and Geometry & Center for Frontiers in Nuclear Science at Stony Brook



- High energy frontier
 - Precision QCD, SMEFT calculations for the LHC (Higgs physics)
 - Next to leading power SCET effects for Higgs physics
 - Development of new techniques for higher order calculations
- Intensity frontier
 - Precision studies of long baseline ν data
 - Probes of ν cross sections with ultra high energy ν telescopes
 - Dark matter models with light mediators
- Lattice
 - $g-2$ (HVP, LbL), weak interaction matrix elements
 - Heavy flavor (probe R_K lepton number violation)
 - Development of numerical algorithms
 - ML improvements
 - Nucleon structure
- Strong community leadership in $g-2$ theory initiative, Snowmass, LHC working groups, DUNE working groups

Diagram	Order	Value	Relative Error
	α^2	$6845(40) \times 10^{-11}$	0.37 ppm [0.6%]
	α^3	$92(18) \times 10^{-11}$	0.15 ppm [20%]

Synergies with other BNL Programs

- Joint experimental and theoretical efforts
 - Nuclear physics
- Accelerator applications
 - Isotope production (BLIP)
 - Space radiation studies (NSRL)
 - Industrial applications (Tandems)
- Superconducting magnets developments
 - Joint with nuclear physics and fusion
- Detector technologies
 - Multiple fields
- Computing facilities
 - Joint center with nuclear physics and basic energy sciences
- QIS center
 - Quantum computing applications
- Electron Ion Collider
 - First physics in early 2030's

BNL Hadron Accelerators Complex

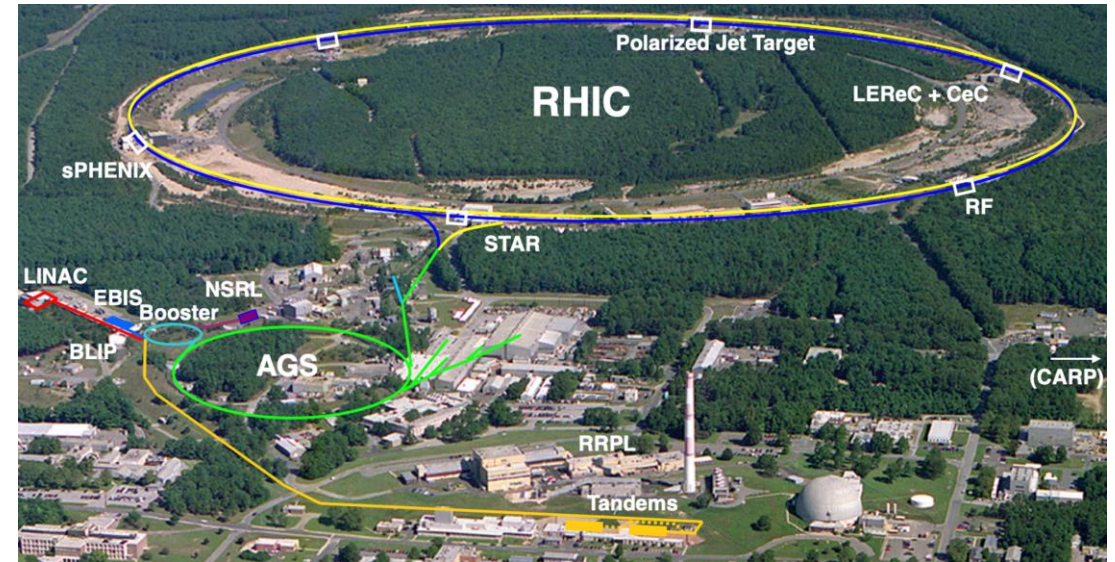

Electron Ion Collider

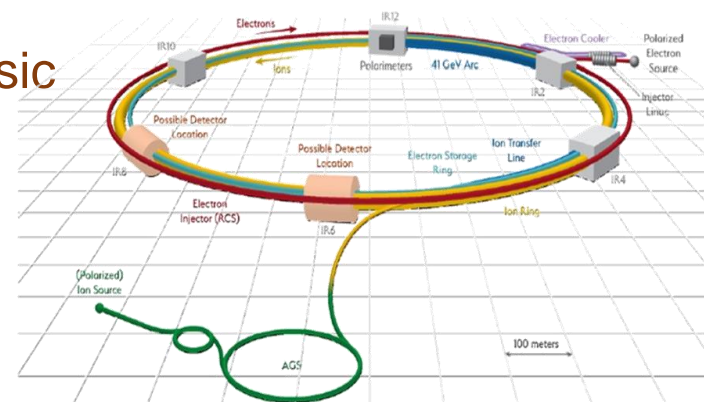

NASA Space Radiation Lab



RHIC – a Unique Research Tool

- Heavy ion collisions
 - Explore new state of matter: Quark Gluon Plasma
 - Highest collision rates and collide many different ion species
- Polarized proton collisions
 - Only collider of spin polarized protons to explore the internal spin structure of protons.
 - Gluons carry part of proton spin

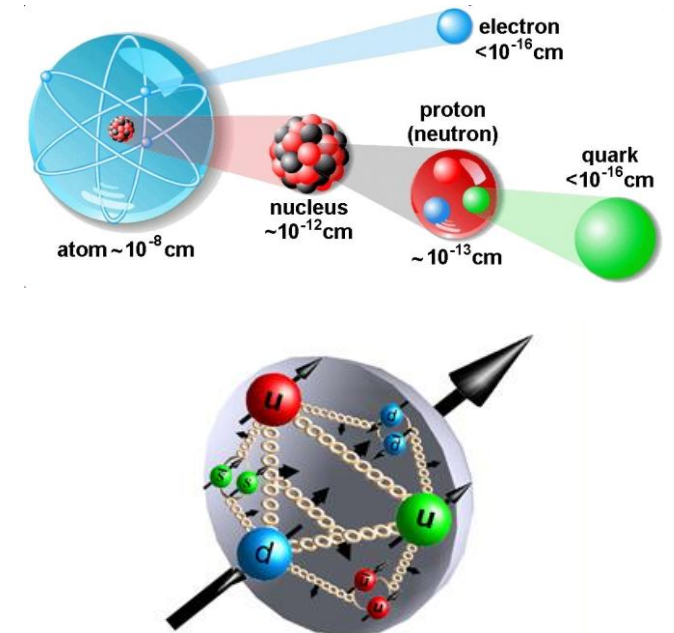
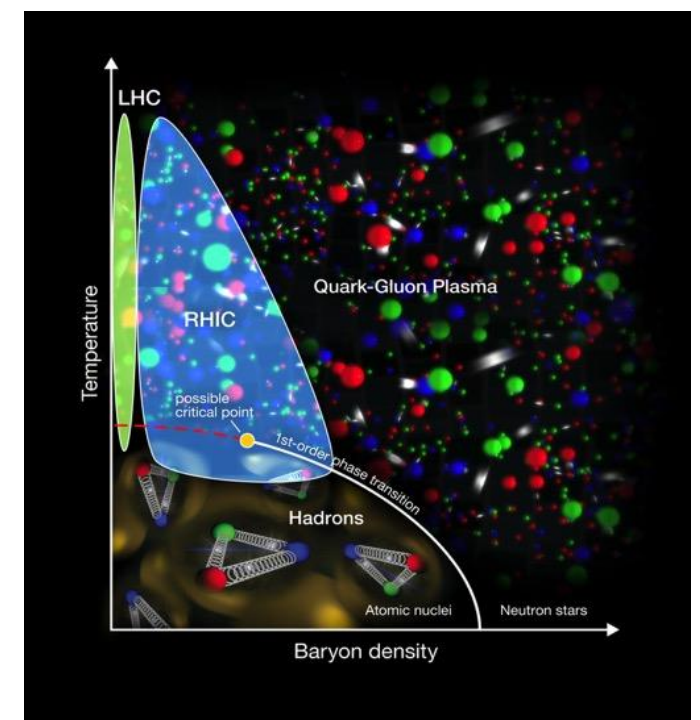

Relativistic Heavy Ion Collider (RHIC) Complex

Uniquely flexible and only hadron collider in US for exploration of QCD phase diagram and proton spin

Injectors also used for application programs:

- Linac/BLIP for isotope production
- Booster/NSRL for space radiation studies
- Tandem for industrial/academic users

R&D for future facilities and application sources, cooling, pol. beams, ...

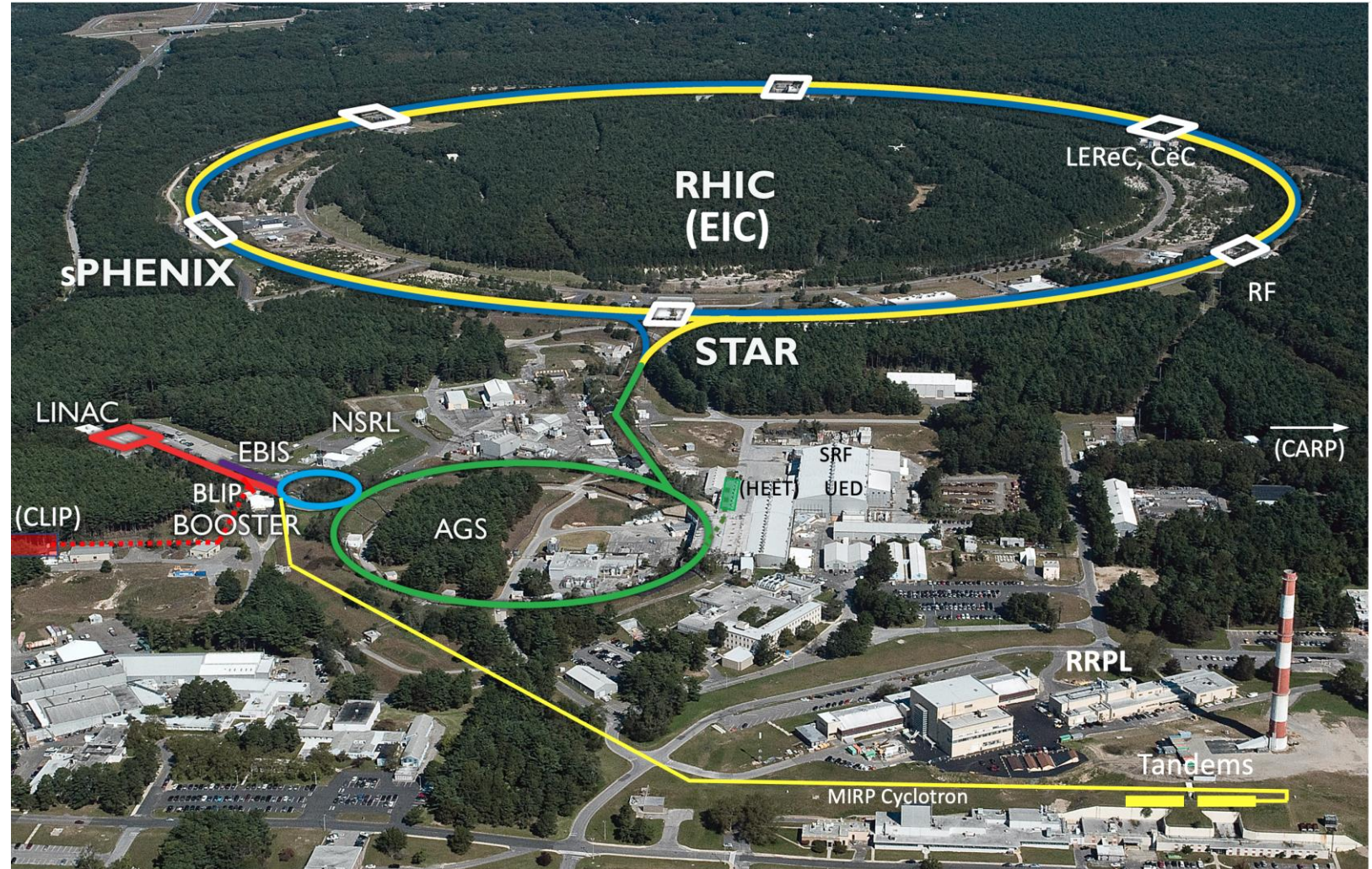

Completing the RHIC Mission with sPHENIX and STAR

- sPHENIX will use energetic probes (jets, heavy quarks) to study quark-gluon plasma with unprecedented precision
 - How the structureless "perfect" fluid emerges from the underlying interactions of quarks and gluons at high temperature
- sPHENIX outer hadron calorimeter will be part of the EIC project detector
- STAR with forward upgraded detectors will understand the initial state of nucleon and nuclei from high to low x and the inner workings of QGP
- How are gluons and sea quarks distributed in space and momentum inside the nucleon?
- How does a dense nuclear environment affect quarks and gluons, their correlations, and their interactions and giving rise to non-linear effects?

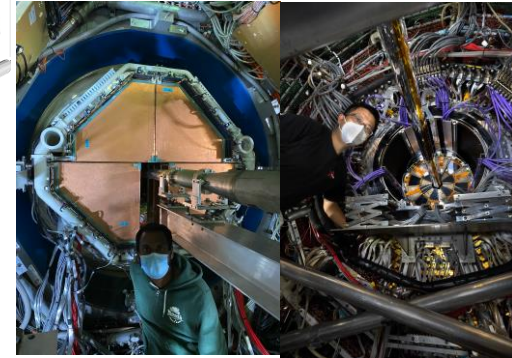
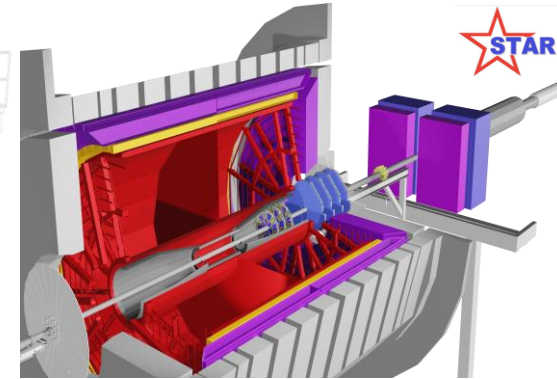
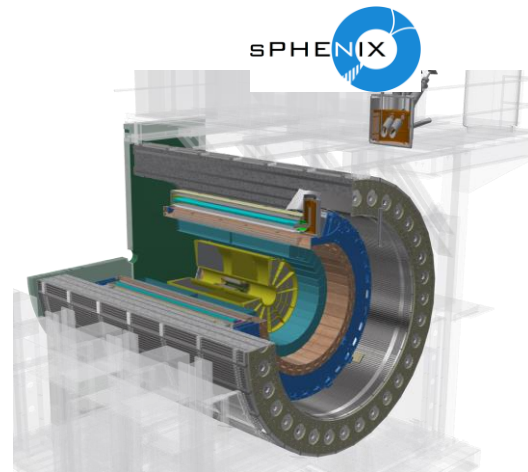
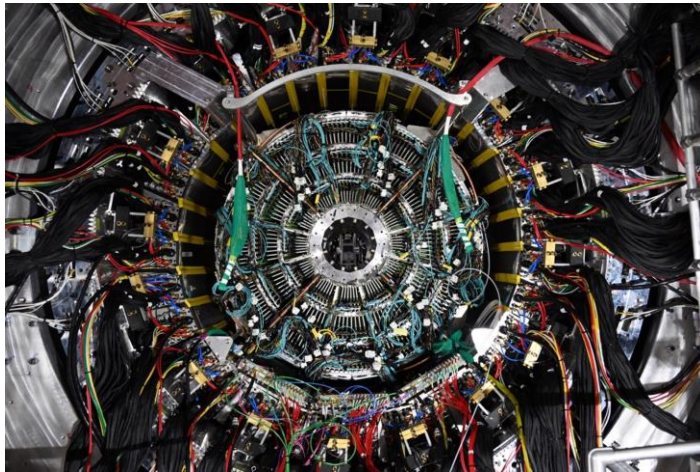

Synergies with the EIC science and contribute to EIC workforce development

RHIC data taking scheduled for 2024–2025
sPHENIX and STAR with forward upgrade will fully utilize the enhanced (~50 times Au+Au design) luminosity of RHIC

sPHENIX commissioning 2023. Now ready for data for Run 24.

- Commissioning with beam started May-August 2023. Now ready for Run 24, expected to begin in April 15, 2024. Length depends on the Budget allocation. Awaited.
- Ten sub-detectors* and DAQ commissioned
- SC magnet operated very stably
- All sPHENIX subsystems, including the MVTX, have taken RHIC data and stored in HPSS
- Excellent support from C-AD to provide wide variety of RHIC beam conditions
- Recent focus had been on operation of TPC at full HV and on MVTX response.

*MVTX, INTT, TPC, TPOT, EMCal, iHCal, oHCal, MBD, sEPD, ZDC/SMD

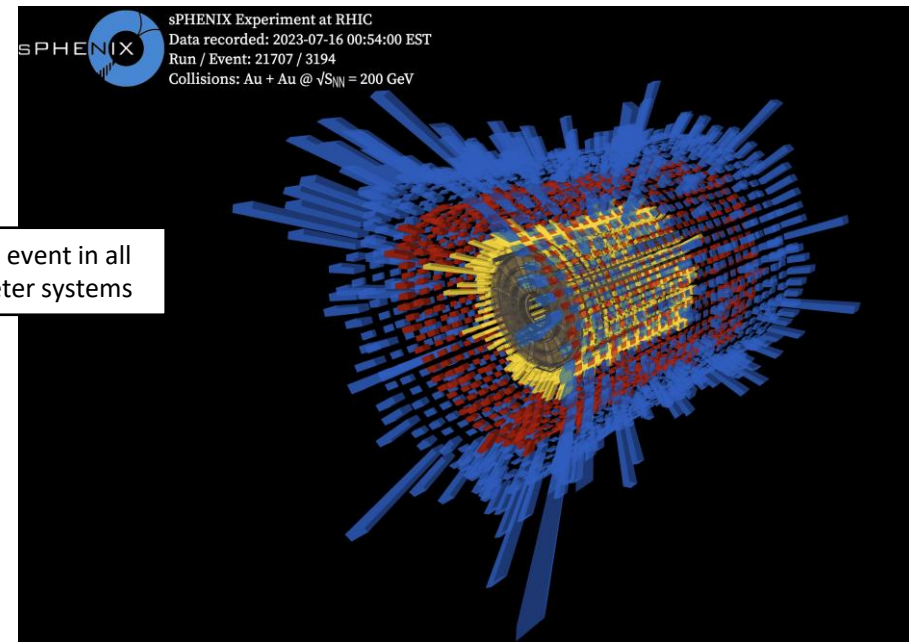

Central Au+Au event in all three calorimeter systems

Reconstruction of vertex location along beam axis using INTT silicon strip detector

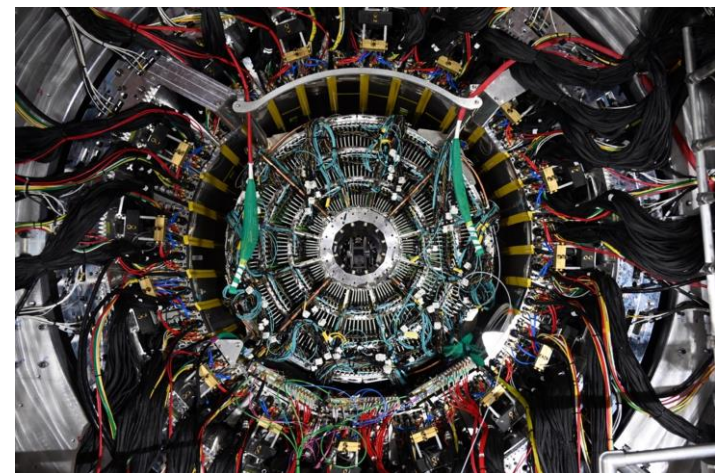
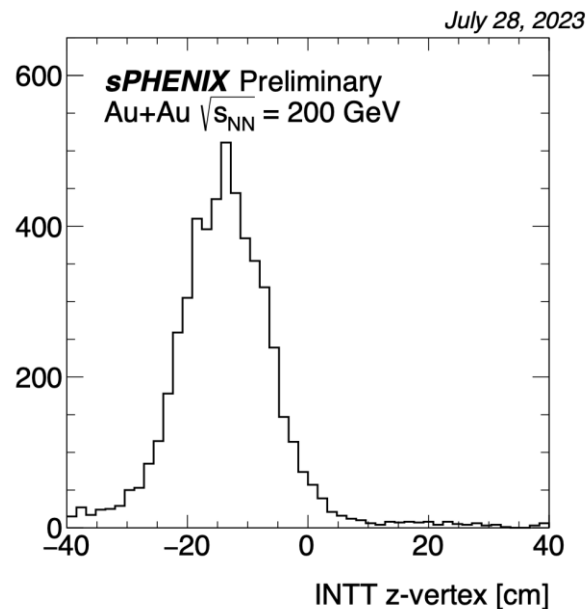



National Academy's Assessment, July 2018

Electron Ion Collider

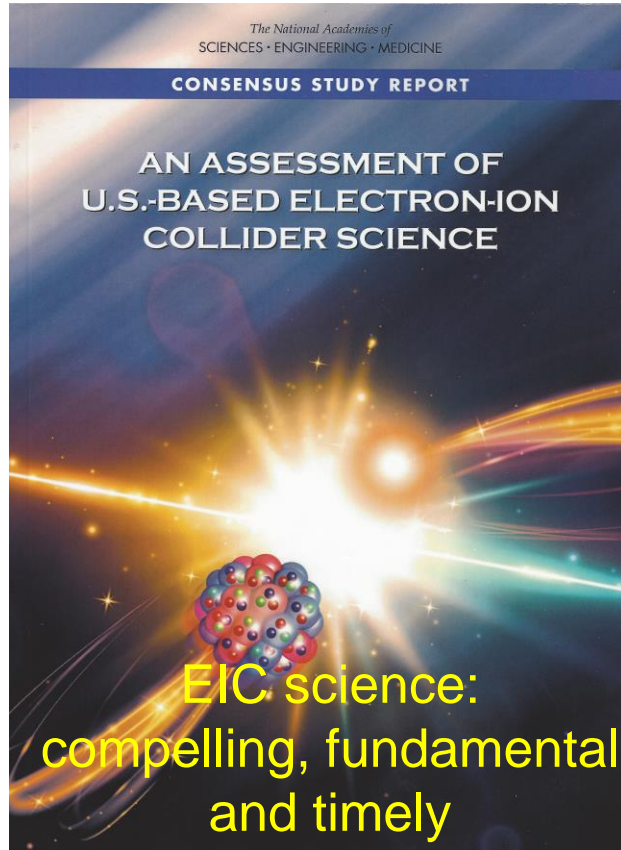

Electron Ion Collider Science:

- Origin of nucleon spin
- Understanding the origin of mass
- Intense gluonic fields & novel gluonic matter

Machine Design Parameters:

- High luminosity: $up\ to\ 10^{33}-10^{34}\ cm^{-2}sec^{-1}$
 - a factor ~100-1000 times HERA
- Broad range in center-of-mass energy: ~20-100 GeV upgradable to 140 GeV
- Polarized beams e-, p, and light ion beams with flexible spin patterns/orientation
- Broad range in hadron species: protons.... Uranium
- Up to two detectors well-integrated detector(s) into the machine lattice

Use of AI and ML in both operation, optimization of machine and data acquisition (triggerless data collections)

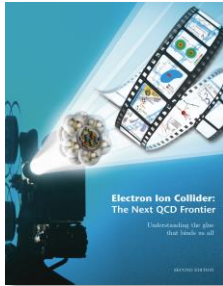

EIC Accelerator Design

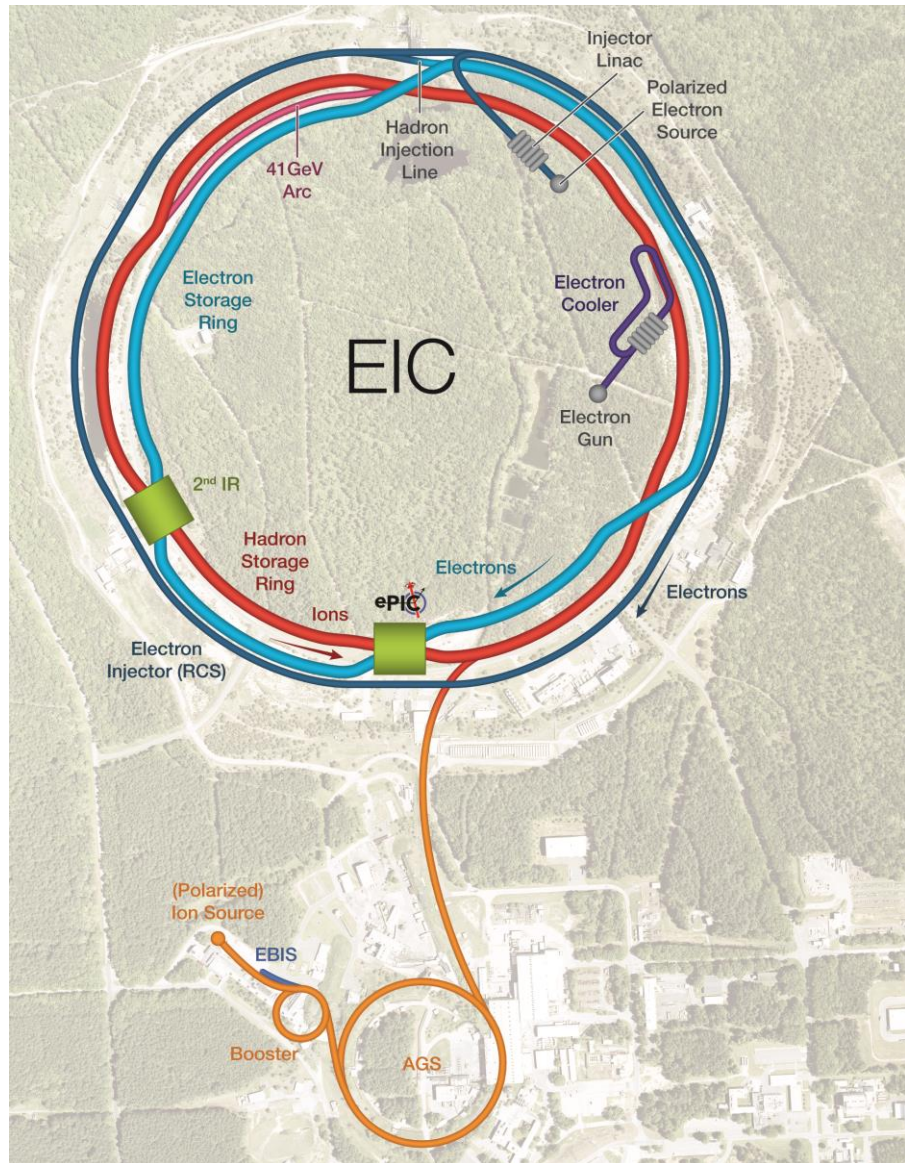

Center of Mass Energies:	20GeV - 140GeV
Luminosity:	$10^{33} - 10^{34} \text{ cm}^{-2}\text{s}^{-1}$ / 10-100fb ⁻¹ / year
Highly Polarized Beams:	70%
Large Ion Species Range:	p to U
Number of Interaction Regions:	Up to 2!

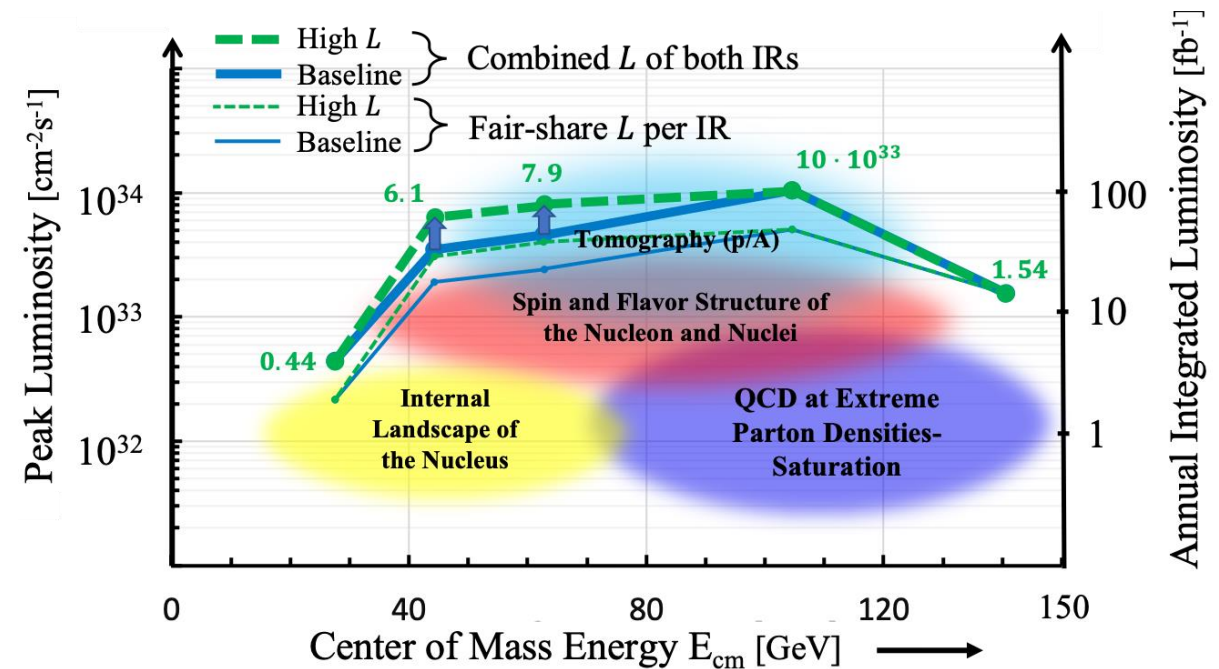

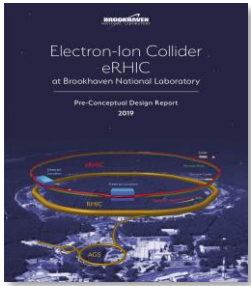

The US Electron Ion Collider

CD0: Dec. 2019, CD1 July 2021

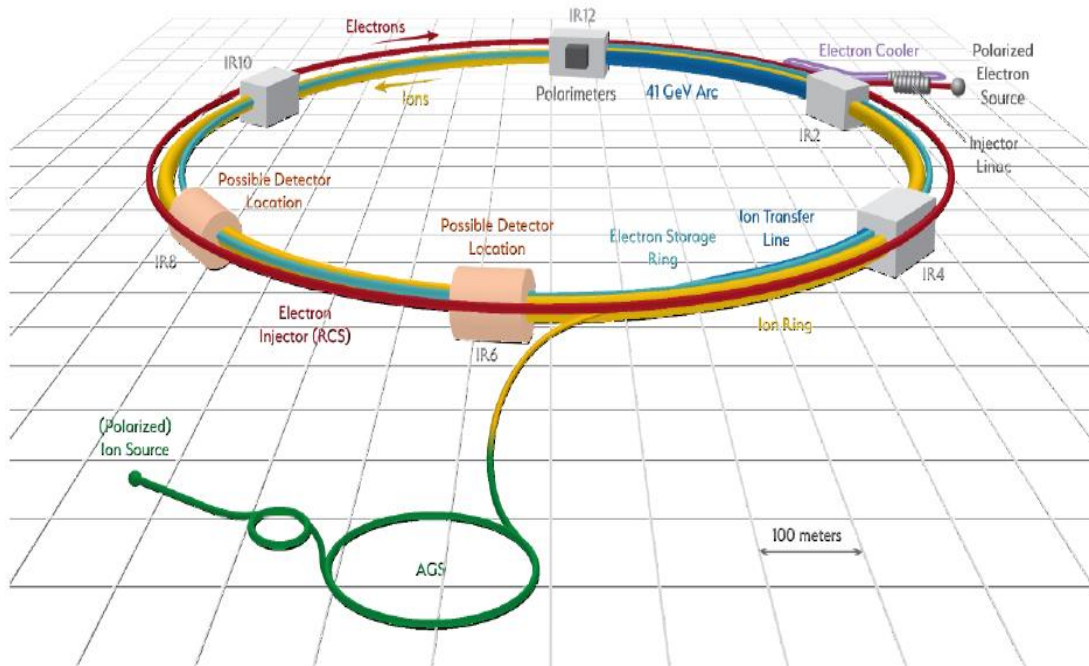

- ❖ Electron storage ring with frequent injection of fresh polarized electron bunches
- ❖ Hadron storage ring with strong cooling or frequent injection of hadron bunches
- ❖ AI and ML surely will play a major role in optimizing this complex accelerator operation

Hadrons up to 275 GeV

- Existing RHIC complex: Storage (Yellow), injectors (source, booster, AGS)
- Need few modifications
- RHIC beam parameters fairly close to those required for EIC@BNL

Electrons up to 18 GeV

- Storage ring, provides the range $\sqrt{s} = 20\text{-}140$ GeV. Beam current limited by RF power of 10 MW
- Electron beam with variable spin pattern (s) accelerated in on-energy, spin transparent injector (Rapid-Cycling-Synchrotron) with 1-2 Hz cycle frequency
- Polarized e-source and a 400 MeV s-band injector LINAC in the existing tunnel

Design optimized to reach 10^{34} $\text{cm}^{-2}\text{sec}^{-1}$

Central Detector Non-DOE Interest & In-Kind

*US involved
in all sub-
systems
not shown
explicitly*

ePIC Detector

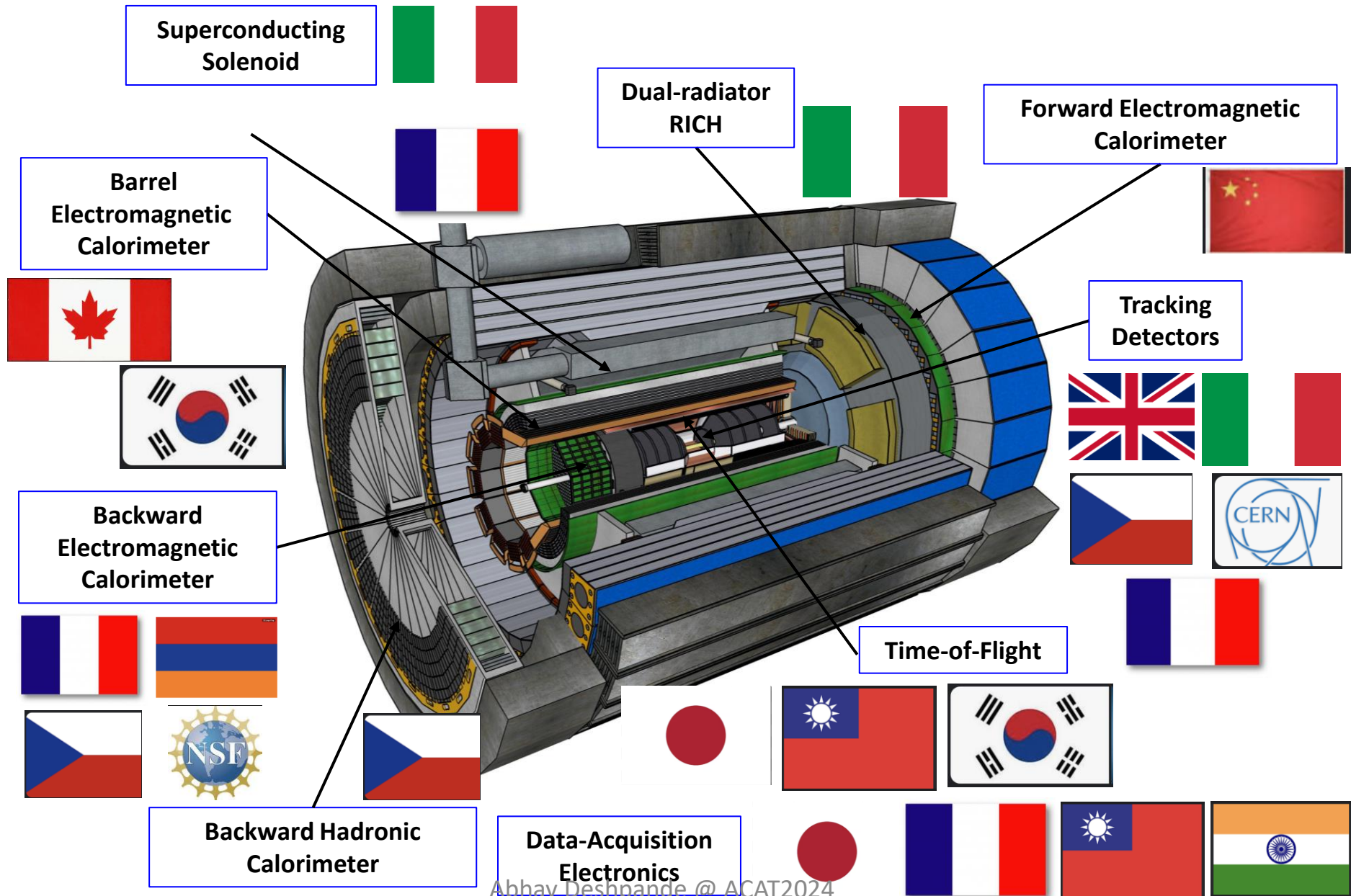

Worldwide Interest in EIC

The EIC User Group:
<https://eicug.github.io/>

- 1450+ collaborators,
- 45+ countries,
 - 287 institutions
- as of January 2024.

Strong International Participation.

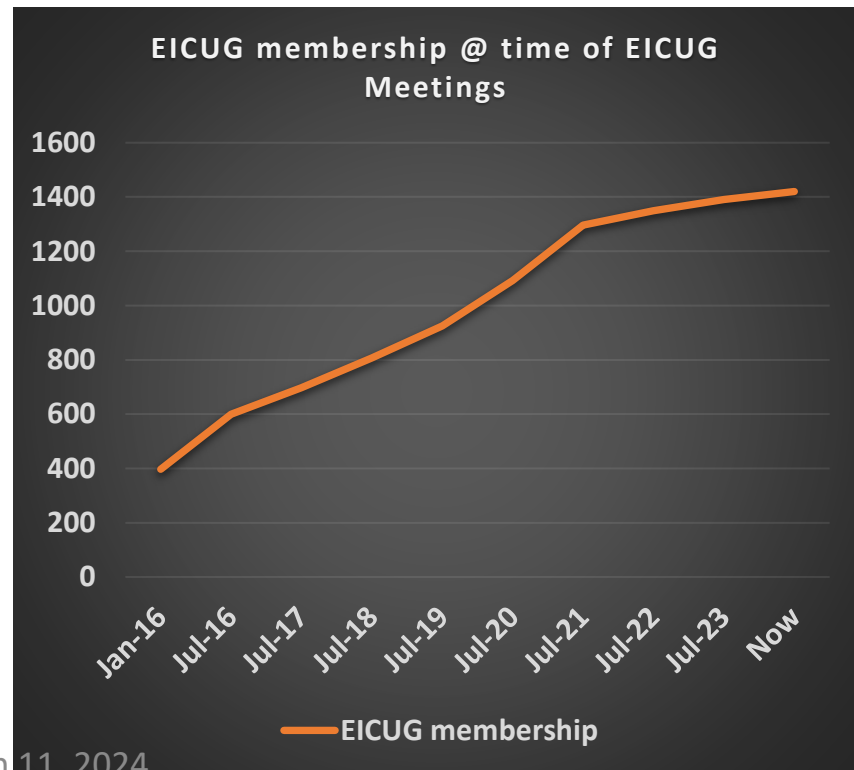
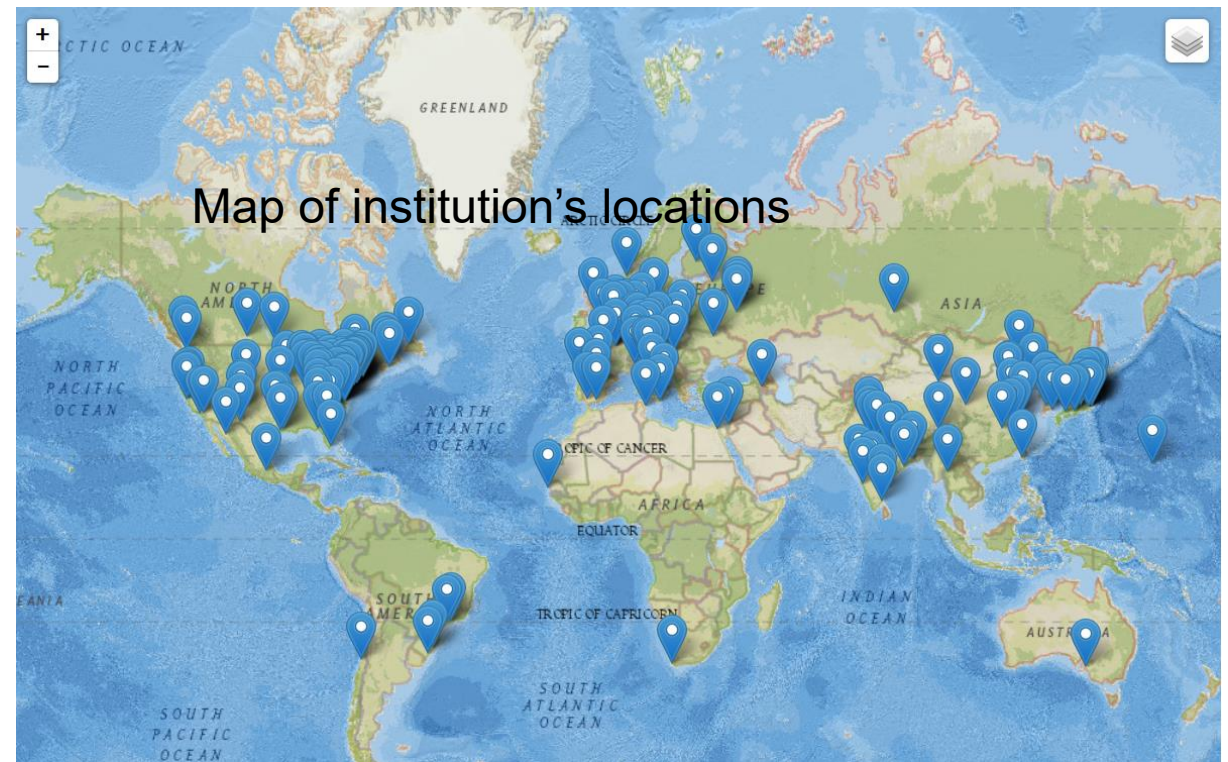

Annual EICUG meeting

- 2016 UC Berkeley, CA
- 2016 Argonne, IL
- 2017 Trieste, Italy
- 2018 CUA, Washington, DC
- 2019 Paris, France
- 2020 FIU, Miami, FL
- 2021 VUU, VA & UCR, CA
- 2022 Stony Brook U, NY
- 2023 Warsaw, Poland
- 2024 Lehigh U, PA

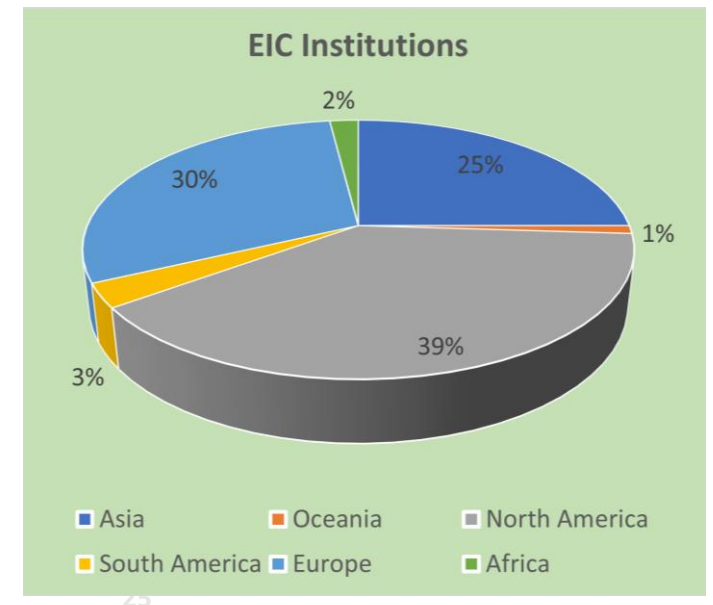

Computing

- Particle physics leads in the complexity and amount of the data collected and analyzed. Nuclear Physics complements this for complexities of detectors and pattern recognition in heavy ion physics.
- Computing requirements of HL-LHC and DUNE are substantial
 - Solving them will advance computing frontier
- Synergies with other fields and industry must be explored
 - Joint computing facilities, DOE HPC
 - Cloud computing, ASCR
- BNL is a leader and strong partner in providing computing support for current experiments and developing future ideas.
- **Institute of Advanced Computational Science (IACS) at Stony Brook**, complements by participating in interdisciplinary activities beyond NP and HEP (Ecology, biology, chemistry....)

Computing challenges of LHC and DUNE

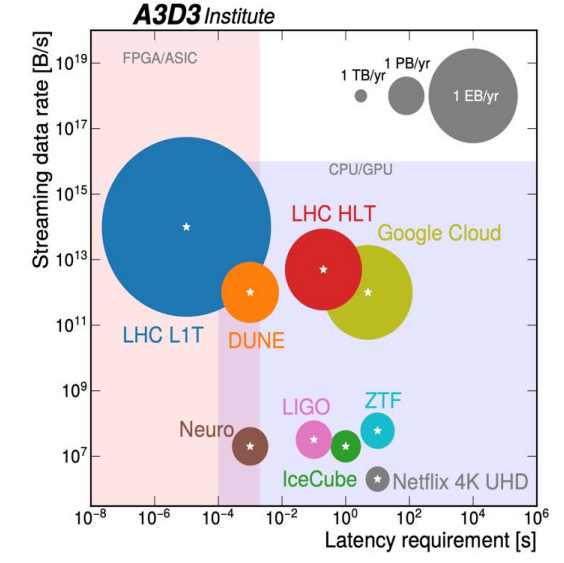
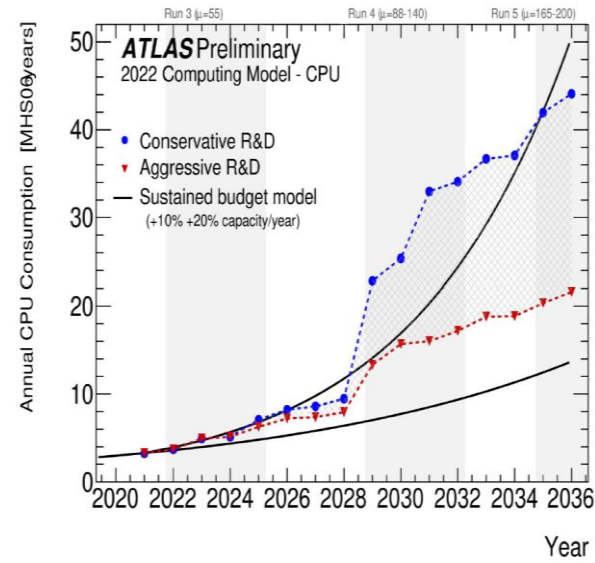

New BNL computing facility for ATLAS, RHIC and Belle II



Accelerators and Detectors R&D

- Accelerators R&D is critical to develop next generation of colliders (Particle, nuclear and photon sciences and medicine)
 - Targeted R&D to develop (high field) magnets
- Cost and energy consumption reduction are important
 - Use of new technologies, such as high temperature superconductivity, are critical
- Particle detectors R&D
 - To enable scientific goals of the field
 - Synergies with other fields and industry
 - BNL leads in multiple areas in cooperation with universities (including – in particular Stony Brook) and national labs partners

BNL HTS/Hybrid common coil dipole design study

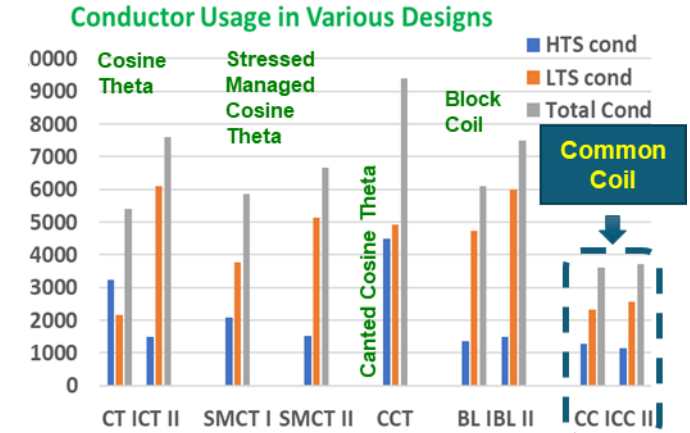

Students visiting BNL LAr R&D facility

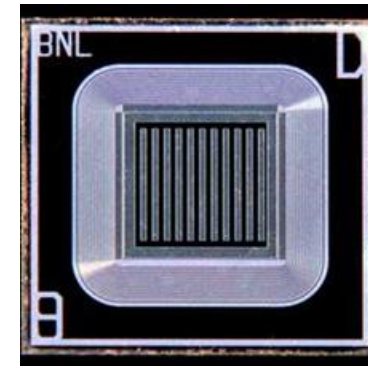

AC-LGAD manufactured at BNL

National Initiatives

- BNL is strongly contributing to and benefiting from the national initiatives; Stony Brook also aspires to participate with a broader scientific interest and perspective (than just NP and Particle Physics)
- AI/ML initiative
 - AI/ML tools are used in HEP for decades, including for discoveries. Now growing beyond those fields.
 - Particle physics is in excellent position to contribute and benefit from the industrial scale AI/ML developments
- Quantum Information Science (QIS) initiative
 - HEP has unique expertise, including in detection of quantum states
 - Excellent potential for theoretical calculations and simulation using quantum computers
 - Developing program beyond initial QuantISED HEP initiative
- Microelectronics
 - Area where BNL led, including ASIC operations at cryo temperatures, for decades

AI/ML tools are used in Higgs studies

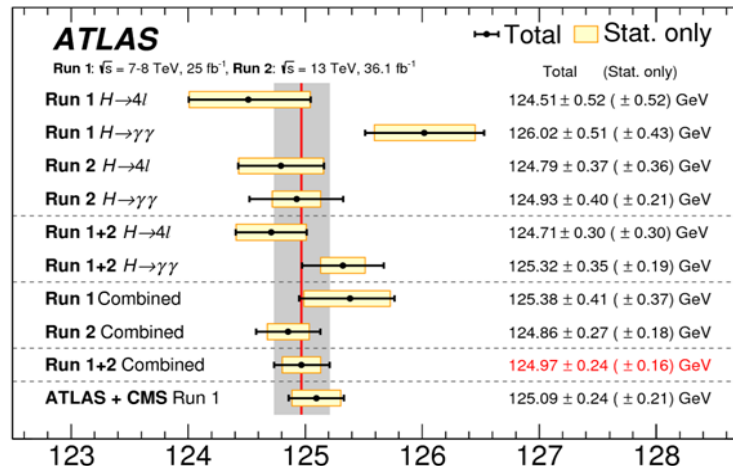

BNL Microelectronics Laboratory





Center for Frontiers in Nuclear Science

<https://www.stonybrook.edu/cfns/>

**Founded jointly by Stony Brook & BNL
in September 2017**

Simons Foundation support till 2027/8
+ NY State : Renovations at Stony Brook
+ BNL : Renovations at BNL (Seminar Room)



Stony Brook University

Vision:

A Center for all scientists interested in the US Electron Ion Collider (& related particle and nuclear Science)

A “home” for

- scientific discourse and
- **attract & support young scientists → EIC/QCD**
- help seed future detector & theory collaborations

Capture EIC for BNL

Work with the EIC Users Group & BNL+ JLab & DOE to help realize the US Electron Ion Collider.

CFNS Activities

- **CFNS post-doctoral fellow and joint CFNS-Remote University program** ~ 20 graduates of the Center since 2018. ALL tenure track or tenured at institutions world-wide created EIC related scientific initiative
- CFNS [Workshops and Adhoc Meetings](#)
- SBU-BNL [Joint Seminars](#) : Twice a month broadly on QCD (Thursday 4:00PM)
- Short- (& **long-term**) visitor program: ~7 days - ~ 30-(**90+**) days
 - Coordinated effort with the EIC Theory Center – Raju Venugopalan (since 2023)
- CFNS QCD summer school: **International participation (see next slide)**
- **AI and ML in nuclear physics and accelerator science a new initiative @ CFNS**
- **Edward Bouchet Initiating** (since 2022) to support under-represented minorities

Total of ~750 visitors/year at the Center through the hybrid in-person/remote activities

CFNS EIC QCD Summer School 2019-2023 (except 2020)

~180 students from 26 countries have attended The School at Stony Brook
Institutions from which these students came from

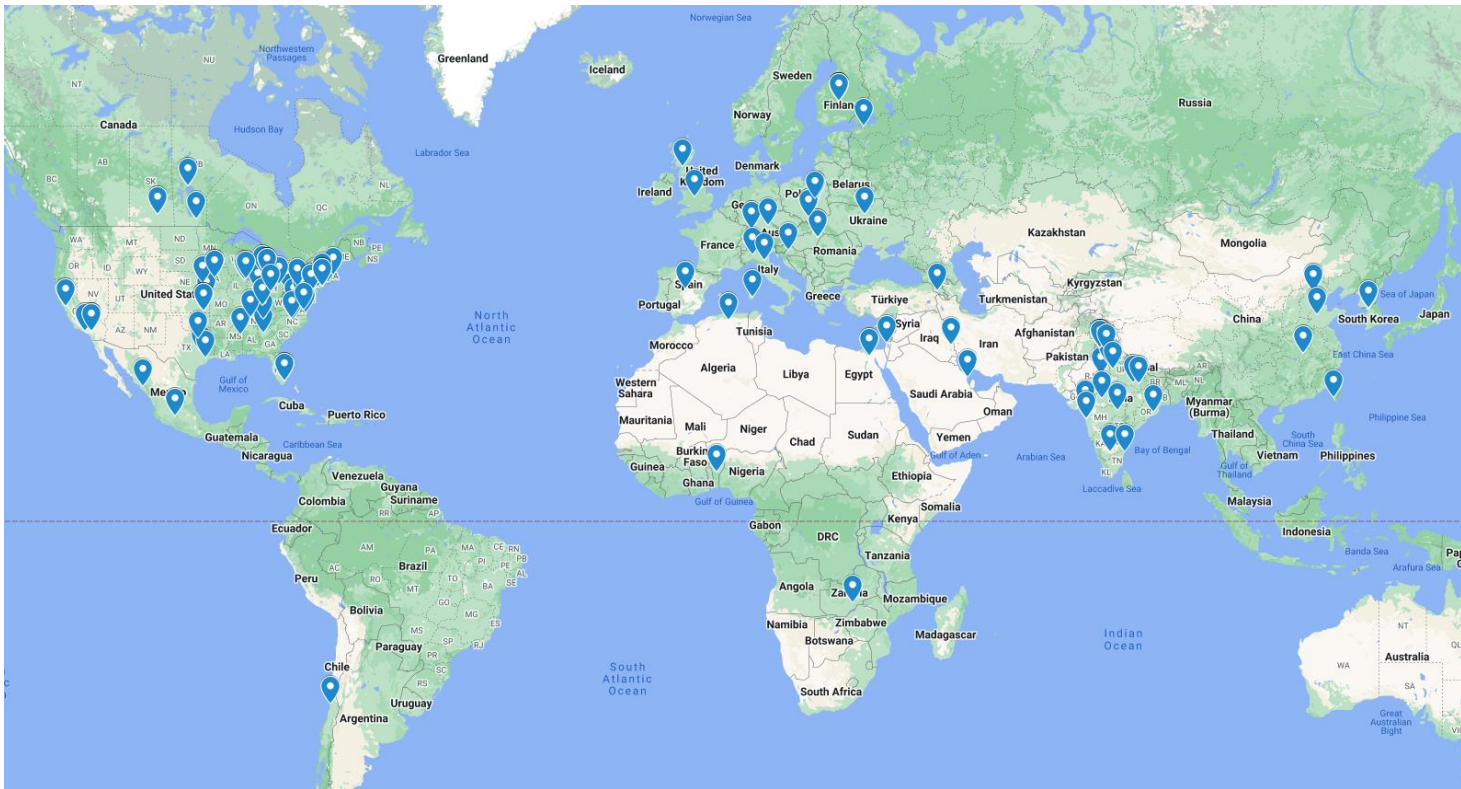

Driven by popular demand FNS Has started EIC QCD Summer Schools: Europe (2023), Asia (2024) and planning to start one in Africa (2024) and South America (~2025)

Institute for Advanced Computational Science (IACS)

Vision: establish SBU at the forefront of data and computing in science, engineering, the arts and humanities through interdisciplinary research... across SBU, SUNY for NY State.

Mission: students, faculty and researchers interact with diverse fields and explore ways to apply modern computing tools and techniques across disciplines

Endowed Chairs and IACS Faculty connect not only to physics, chemistry, mathematics but also biology, ecology and environment...



P5 Proposals: BNL and Stony Brook are Actively Engaged

- DUNE upgrades
 - Physics and modules 3 and 4 upgrade
- Higgs factory
 - FCC due to our close connections with CERN
 - ILC
- Muon collider
 - Unique expertise in accelerator and detectors
- Forward Physics Facility at CERN
 - Neutrinos and energy frontier
- PIONEER
 - Small scale experiment with deep science connection to HEP fundamental principles
- LHCb
 - Have experts in both physics and detectors, upgrade starts after HL-LHC projects
- Various proposals for accelerator, detectors, computing and related R&D

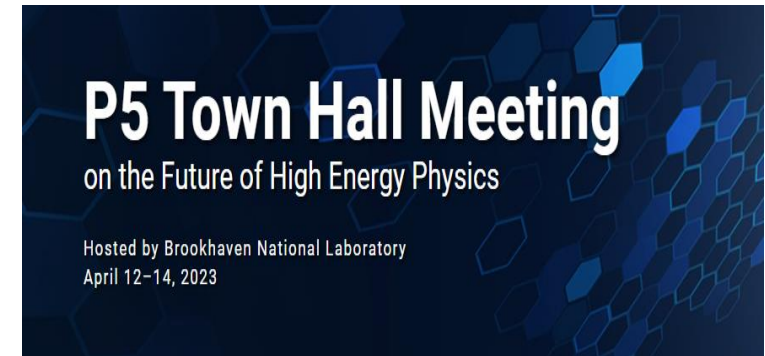

NSAC LRP 2023 Recommendation

BNL and/or Stony Brook involved in all of them

1. Capitalize on extraordinary opportunities made possible by investments in US...
 - ❖ Workforce development, Operate facilities (ATLAS@ANL, CEBAF@Jlab, FRIB, and **complete the RHIC Mission**)
2. and 3.
 - ❖ Lead an international consortium for **neutrino-less double beta** decay experiment
 - ❖ Expeditious completion of **Electron Ion Collider (EIC)** as highest priority facility
4. Capitalize on the unique ways in which nuclear physics can advance discovery science and applications for the society by investing in additional projects and strategic opportunities (detector R&D, support computing, theory, lattice QCD...)





ACAT 2024

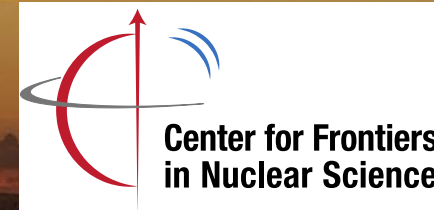

Welcome to you all ACAT2024

Advanced Computing (AI, ML etc.) and Analysis Techniques are crucial for science and society in the next decades to come.

BNL and Stony Brook University aspire to be fully engaged and lead many aspects of this.

We are excited to have you here: all the best this week!



Stony Brook **University**



Backup

Diversity, Equity, Inclusion and Accessibility

- BNL ranked #7 on the top 20 list of government employers by the STEM Workforce Diversity Magazine in 2023
- BNL launched DEI quarterly theme in FY23 Q3 on “Emotional intelligence” and Q4 on “*Inclusion –Cultivating an Inclusive Workplace*” –NPP actively participating and part of the pilot program with the launch
- NPP DEI council has been active with many initiatives (e.g., Code of Conduct committee report)
- [Workshop on Exploring Collaboration with Minority Serving Institutions \(MSIs\) in Nuclear and Particle Physics](#) was a great success at BNL, July 18-19, 2023, 17 MSIs participated including students, DOE-NP, HEP and IP program managers participated in a panel discussion
- Led BNL@ North Carolina Agricultural and Technical State Univ. in April was successful & strong NPP participation
- Working on improving physical spaces and activities to make the working environment more welcoming and inclusive, collaborating with DEI council and ERGs
- Responding to DOE-SC FOAs on FAIR and RENEW programs in collaborations with MSIs
- Workforce development and pipeline: outreach, BNL summer Sundays, SULI, SCGSR, Nuclear Chemistry Summer School, African School of Physics, and more



EIC Network for Discovery Science and Workforce Development

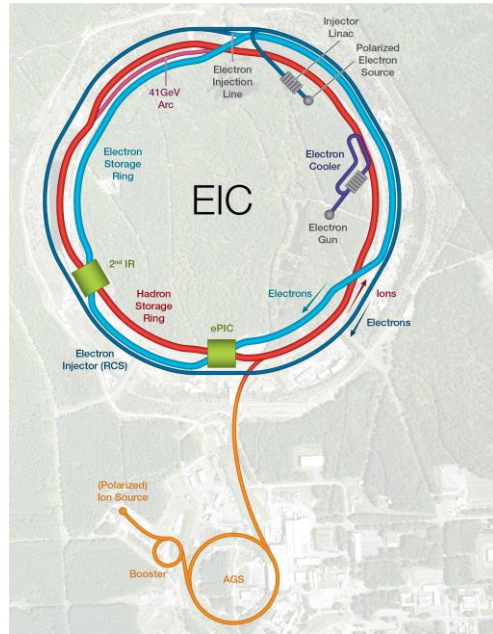

Such a network would empower discovery science at the EIC while strengthening and building nuclear physics research at U.S institutions, especially those with limited research capacities, and supporting training of a STEM workforce for the nation from a broad pool of talent.

The network would promote partnerships between U.S. national labs and universities and supports students and postdoctoral fellows. The network would promote collaborations between experiments and theory, organize traineeships, mentoring and career development programs for students and postdocs.

In addition to discovery science, the nation benefits from a highly skilled STEM workforce for advances in fields such as energy, environment, health, and national security.

