

Prospects for novel track reconstruction algorithms based on Graph Neural Network models using telescope detector testbed

Wojciech Gomułka, Piotr A. Kowalski, Tomasz Szumlak, Tomasz Bołd

AGH University of Krakow
Faculty of Physics and Applied Computer Science



Presentation agenda

1. Graph Neural Networks in particle tracking - related work
2. Graph Neural Networks - idea and principles of application
3. Telescope detector testbed in *A Common Tracking Software* with use of *Pythia*
4. Experiments and results
5. Summary and future plans

1. Graph Neural Networks in particle tracking - related work

| Article | Notes | Scope |
|---|--|--|
| Farrell, Steven, et al. "The HEP.TrkX Project: deep neural networks for HL-LHC online and offline tracking." EPJ Web of Conferences. Vol. 150. EDP Sciences, 2017. | Proceeding about HEP.TrkX project. with LSTM and CNN layers usage. | Tracking, LSTM, CNN, dataset: toy detector (10 layers). |
| Farrell, Steven, et al. "Novel deep learning methods for track reconstruction." arXiv preprint arXiv:1810.06111 (2018) | One of the first mentions of HEP.TrkX project. Relatively "old" paper which describes usage of LSTMs and GNNs in track reconstruction. | Tracking, LSTM, GNN, dataset: ACTS generic detector |
| Biscarat, Catherine, et al. "Towards a realistic track reconstruction algorithm based on graph neural networks for the HL-LHC." EPJ Web of Conferences. Vol. 251. EDP Sciences, 2021. | Post-conference proceeding from CHEP 25th conference . Authors show own GNN architecture (using encoding with 2 x MLP layers and Interconnection Networks known from other publications). | Tracking, GNN, dataset: TrackML |
| Duarte, Javier, and Jean-Roch Vlimant. "Graph neural networks for particle tracking and reconstruction." Artificial intelligence for high energy physics. 2022. 387-436. | Article describing idea of application of graph neural networks in particle tracking and reconstruction process. Describes mathematical formalism behind GNN and has a form of review presenting potential problems addressable in tracking with GNN . | Tracking, GNN, dataset: TrackML |
| Liu, Ryan, et al. "Hierarchical Graph Neural Networks for Particle Track Reconstruction." arXiv preprint arXiv:2303.01640 (2023) | Extensions of ExA.TrkX project, which uses hierarchical GNN with new loss function dedicated to the problem of tracking. | Tracking, GNN, dataset: TrackML |

...and many more

2. Graph Neural Networks - principles and ideas of application

- One of the basic concepts is treating cloud of hits as input graph
- The task is then to predict existence of edges between two hits
- As many other methods, **GNNs** are named as potential approach to address HL environment of incoming experiments

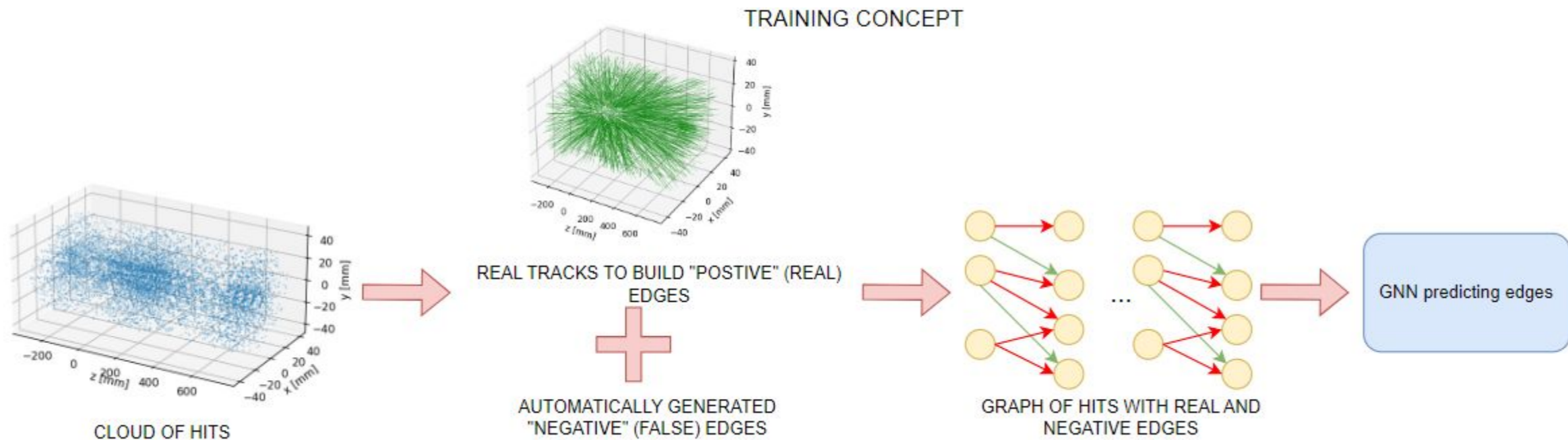

3. Telescope detector testbed in *A Common Tracking Software* with use of *Pythia*

We leveraged *TelescopeDetector* from *ACTS* to build simple toy-detector, partially resembling *VELO*'s geometry in number of layers, their shape and distance between consecutive surfaces. The toy-detector uses **disks with a hole instead of half-disks** (like old *VELO*).

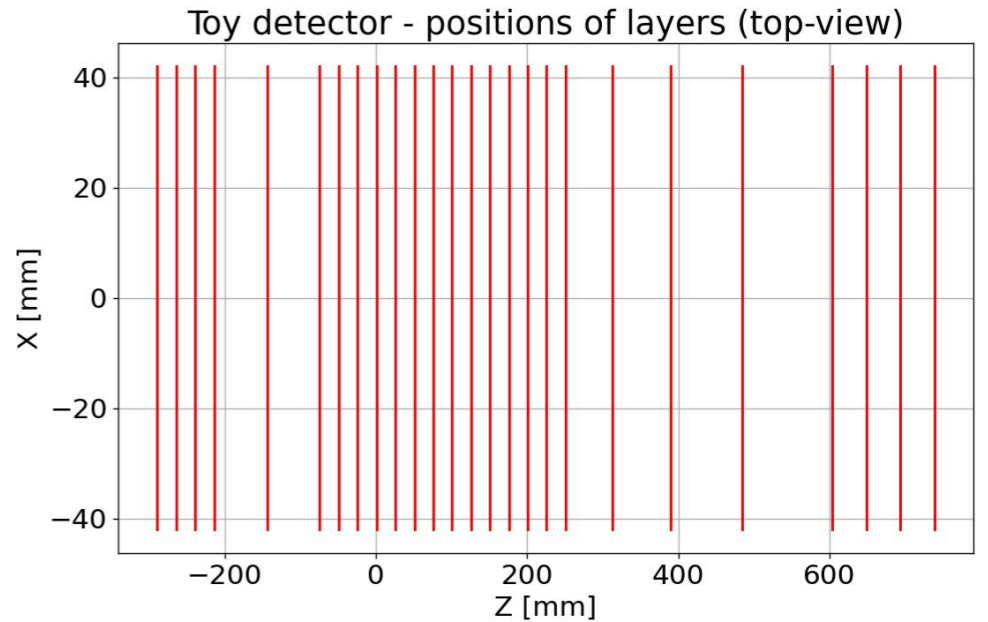

Toy detector - position of layers (front-view)

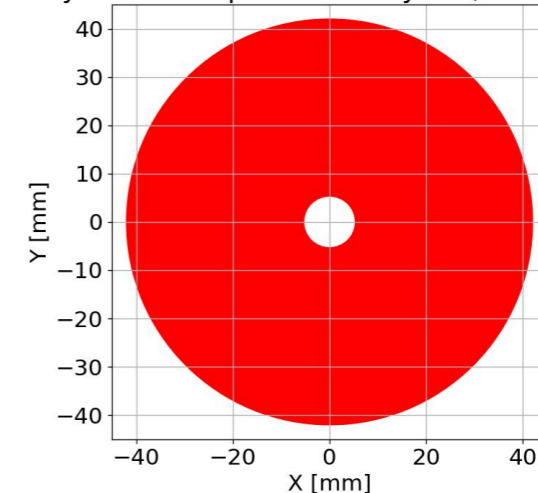

VELO - positions of layers

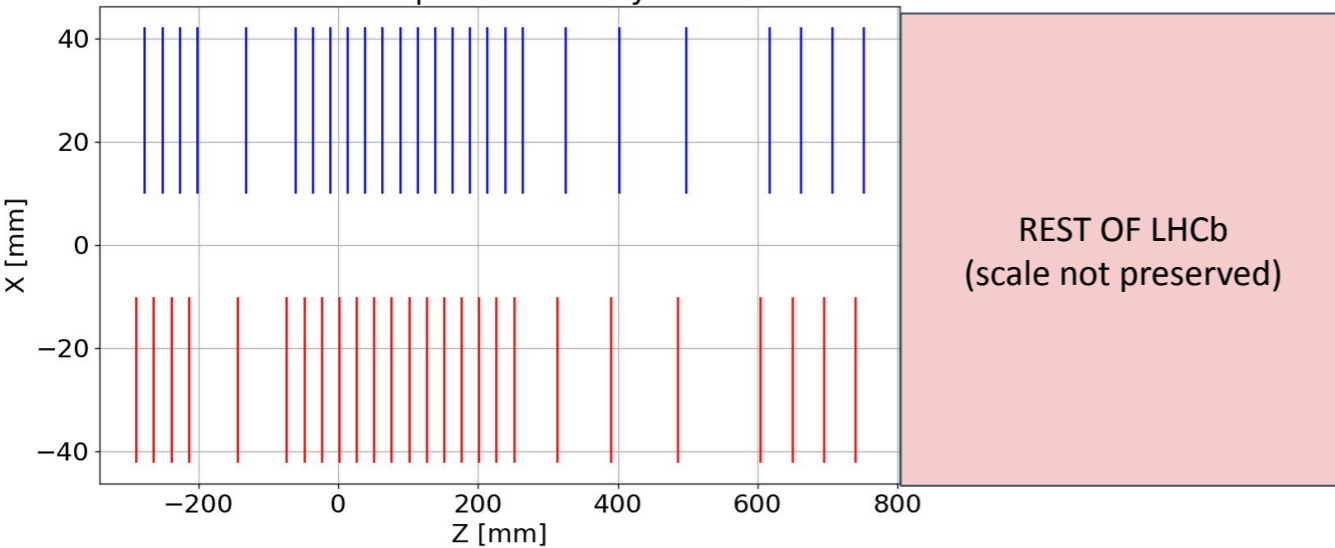

Own figure based on: <https://cds.cern.ch/record/1624070/files/LHCB-TDR-013.pdf>

3. Telescope detector testbed in *A Common Tracking Software* with use of *Pythia*

- Data is created with use of **Pythia** and **FATRAS**
- Physical properties are preserved, as could be seen on the energy histogram
- Distributions of hits and energy of one example event could be found below:

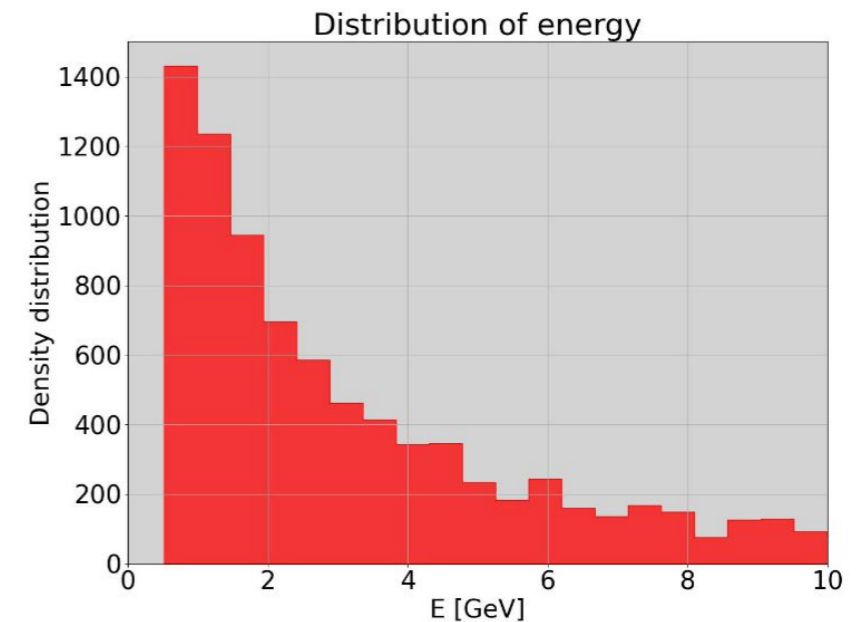
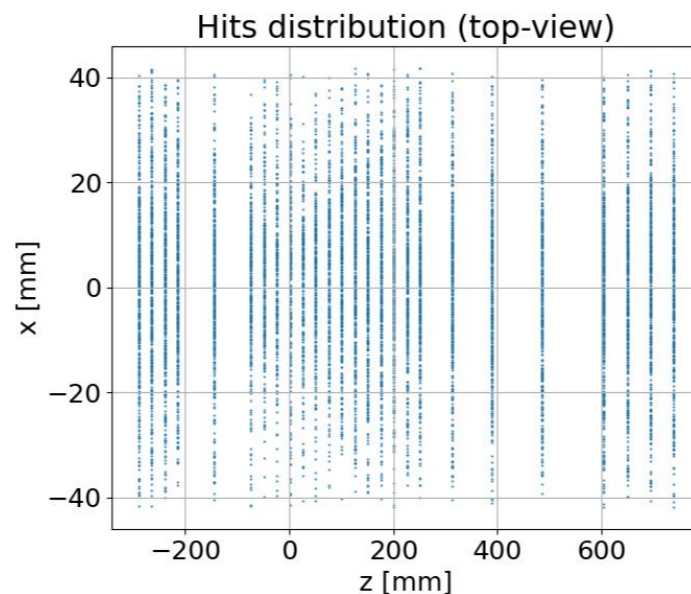
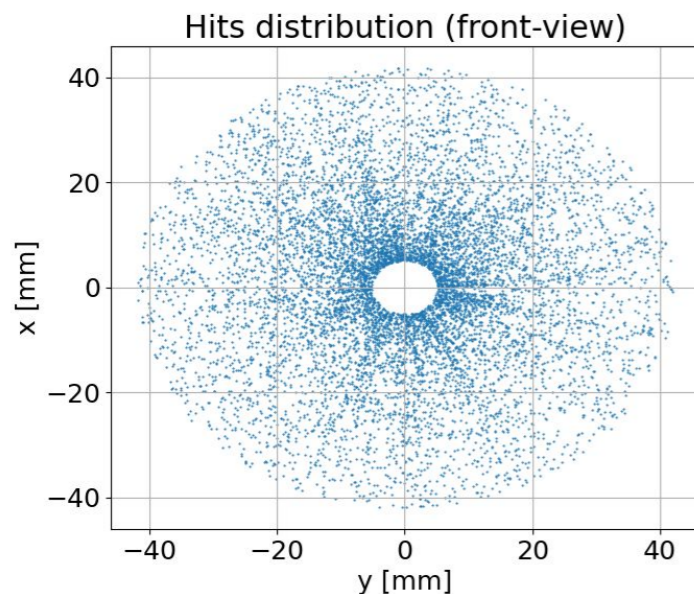

4. Experiments and results

Areas we see as worthy to explore:

- **VELO** and generally **LHCb** topics seem to be less involved in **ACTS** when compared to **ATLAS**
- relatively simpler data from telescope detectors is given less attention than datasets from cylindrical geometry with B field (especially **TrackML** challenge)
- **GNNs** shall be flexible enough to learn on events which operate on environments with no magnetic field ($\mathbf{B} = \mathbf{0}$) - **VELO** case - as well as in those with non-0 magnetic field (**TrackML** / **ATLAS** etc.).
- layers leveraging attention mechanism are not yet used very widely for the tracking problem***

*** - actually, it changes recently as **ExA.TrkX** group is showing second time this year research with use of attentive mechanisms / transformers

4. Experiments and results - previous research

Task:

edge prediction (existence of connection between hits of two consecutive layers).

Simplified example: similar number of positive (received from simulation) and negative edges (randomly generated).

Data:

generated with use of OpenDataDetector.

Outcome:

Counterintuitively, Gated Recurrent Network did not work well.

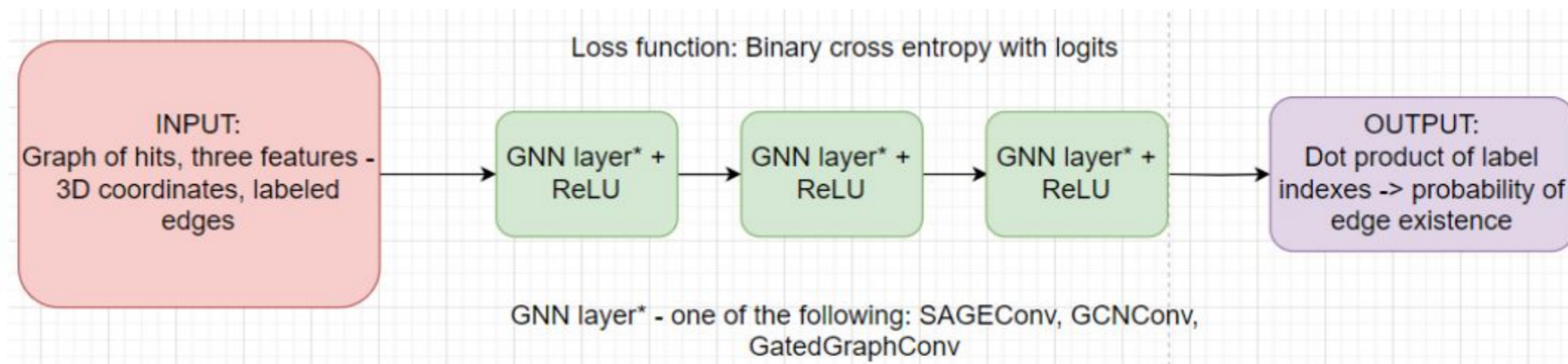

Table 1. Metrics for training of models using different layers

| Metric | SAGEConv | GCNConv | GatedGraphConv |
|---------------------------|----------|---------|----------------|
| Sensitivity | 0.976 | 0.993 | 0.402 |
| Specificity | 0.830 | 0.849 | 0.860 |
| Precision | 0.852 | 0.868 | 0.742 |
| Negative predictive value | 0.972 | 0.991 | 0.590 |
| Accuracy | 0.903 | 0.921 | 0.631 |

4. Experiments and results - current research, usage of transformer layers

Task:

edge prediction (existence of connection between hits of two consecutive layers).

Data:

generated with use **VELO-inspired** toy-detector.

Positive edges - those between hits which belong to ground-truth track

Negative edges - constructed between consecutive layers, selected randomly for training to equalize number of positive edges

Volume:

200 events, each ~10,000 hits and ~2000 particles. Around 80% of data used for training, 10% for validation and 10% for testing.

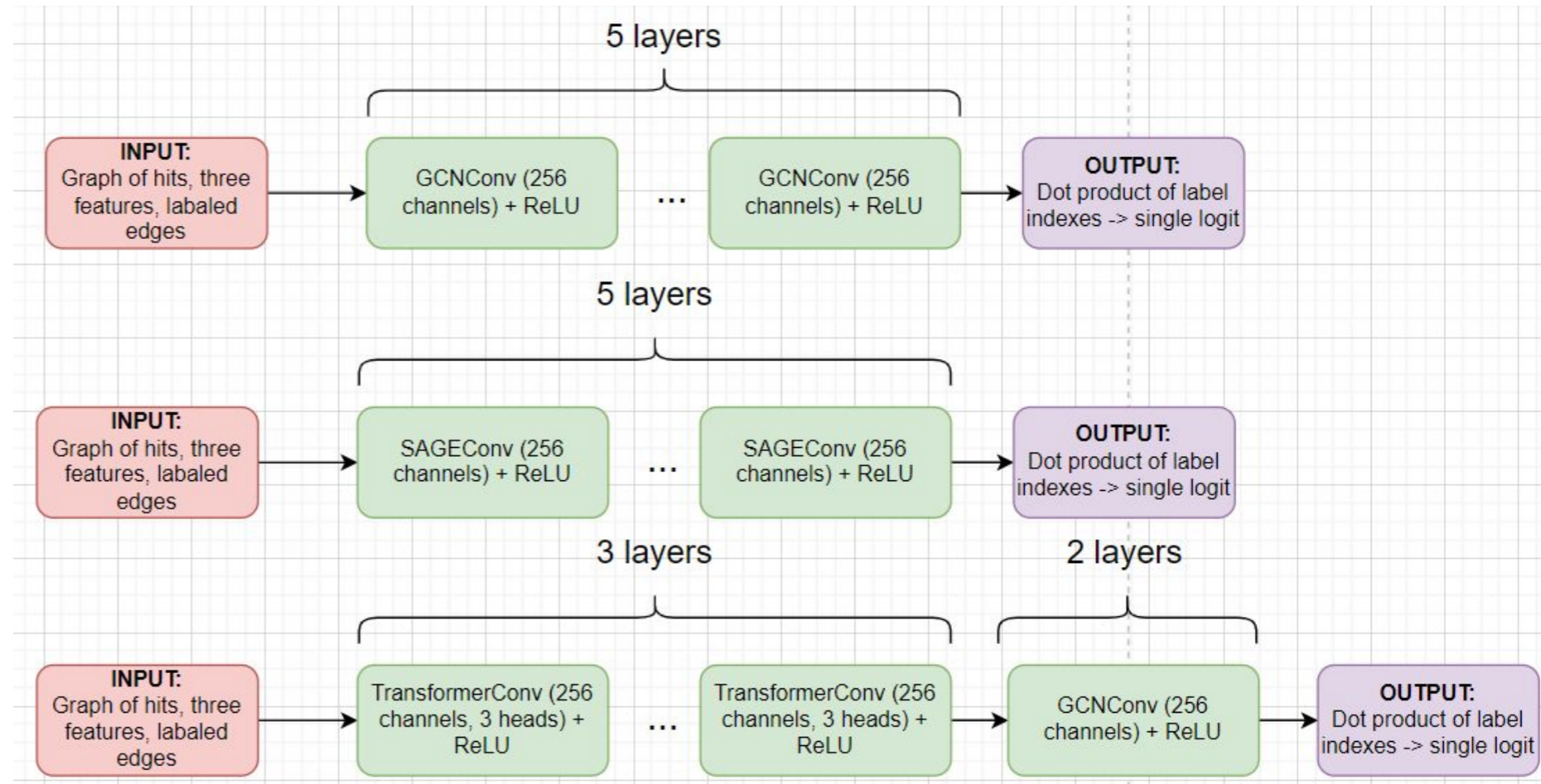

4. Experiments and results - current research, loss (binary cross-entropy with logits)

Loss (binary cross-entropy with logits) for GCNConv model

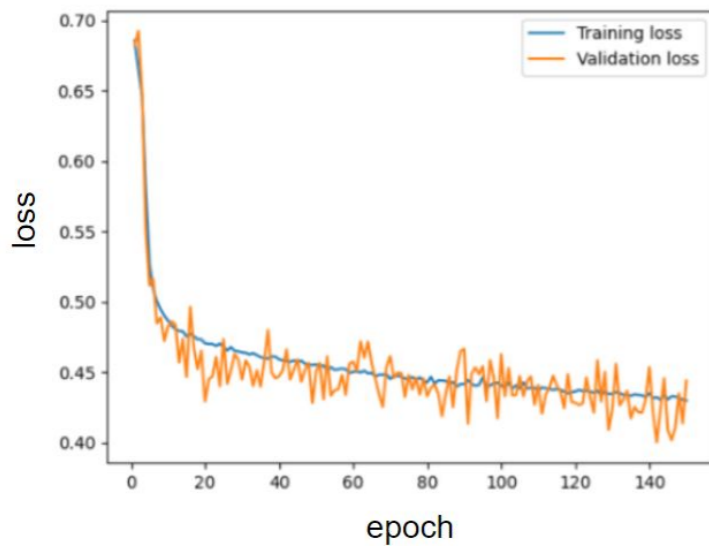

Loss (binary cross-entropy with logits) for SAGEConv model

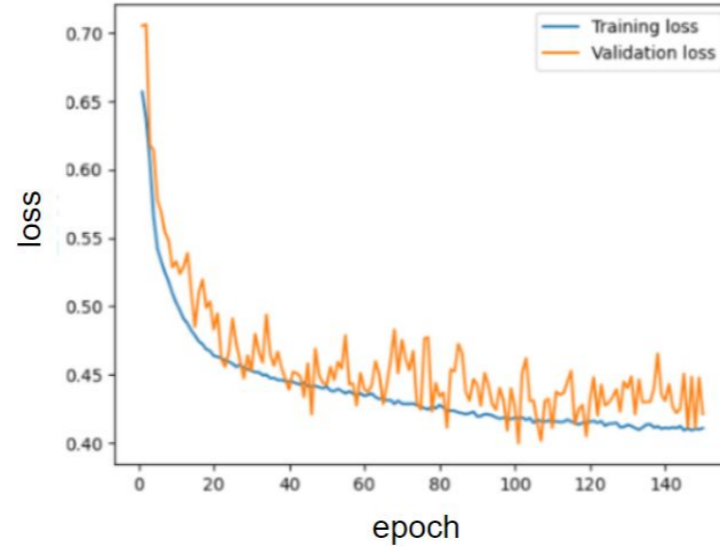

Loss (binary cross-entropy with logits) for TransformerConv model

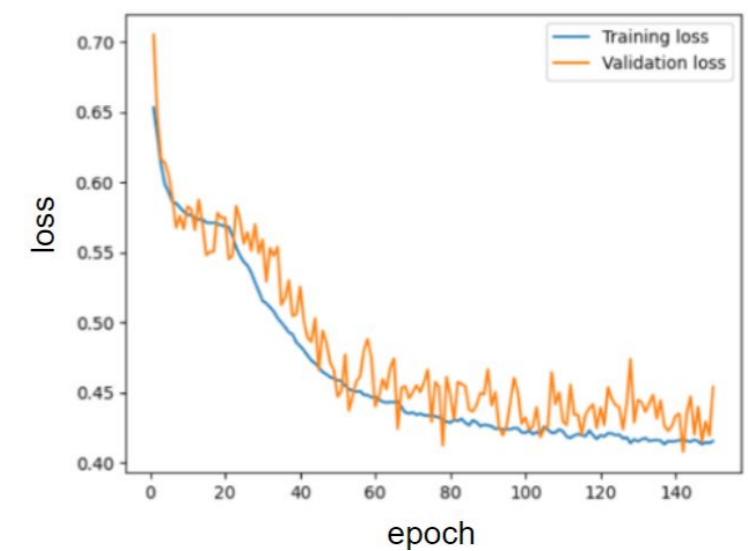

4. Experiments and results - current research, metrics (unseen event), simplified task (similar number of positive and negative edges)

In simplified scenario, metric looks well, but realistically the number of “ghost” seeds would grow significantly due to bigger number of False Positives. Results for SAGEConv and TransformerConv are very close.

| Metric | SAGEConv | GCNConv | TransformerConv |
|---------------------------|---------------|---------|-----------------|
| Sensitivity | 0.9997 | 0.9895 | 0.9987 |
| Specificity | 0.9522 | 0.9409 | 0.9534 |
| Precision | 0.9545 | 0.9434 | 0.9549 |
| Negative Predictive Value | 0.9996 | 0.9890 | 0.9986 |
| F1 score | 0.9766 | 0.9659 | 0.9763 |
| Accuracy | 0.9760 | 0.9651 | 0.9759 |

4. Experiments and results - current research, more realistic (“imbalanced”) scenario

Potential edge is constructed this way: a point from one layer, connected with point from the next, if it lies at most +/- 10 mm (considering both dimensions).

Task is not “simplified”, but “realistic” - imbalanced data (in the considered example, there is **52:1** ratio of negative to realseeds among potential edges).

$$Eff = \frac{\text{correctly reconstructed real seeds}}{\text{all real seeds}} \times 100\%$$

$$Fake\ ratio = \frac{\text{wrongly reconstructed seeds}}{\text{all reconstructed seeds}} \times 100\%$$

Transformer, 100 epochs, 200 events

$$Eff = \frac{5841}{5942} \times 100\% \approx 98.3\%$$

$$Fake\ ratio = \frac{38414}{44225} \times 100\% \approx 86.8\%$$

Fake ratio is very concerning, but not terrible considering data imbalance.

Transformer, 100 epochs. 500 events

$$Eff = \frac{5775}{5942} \times 100\% \approx 97.19\%$$

$$Fake\ ratio = \frac{33925}{39700} \times 100\% \approx 85.4\%$$

Training was performed with use of NVIDIA GeForce RTX 4050.

5. Summary and future plans

1. On the one hand, we managed to show a few **GNN** layers as a natural tool for edge prediction and **ACTS** as a testbed for telescope detectors like **VELO**.
2. On the other hand fake ratio received so far is absolutely not acceptable, even for seeds.
3. As it might be associated with pre-filtering, it is worth to verify if this is a matter of the network or actually a data.
4. Nevertheless, probably there is a need to use significantly bigger data volumes, i.e. 10,000 events (not a problem to generate with **ACTS + Pythia** and **FATRAS**)
5. Need to verify what is effect of extending dataset to efficiency results.
6. Maybe it would be rational to simplify the task temporarily by limiting the pile-up before taking next steps.

THANK YOU FOR ATTENTION!

Acknowledgements:



We gratefully acknowledge the funding support by program “Excellence initiative—research university” for the **AGH University of Krakow** as well as the **ARTIQ** project: UMO-2021/01/2/ST6/00004 and ARTIQ/0004/2021. T. Bold is supported by Polish Science Centre grant UMO-2023/51/B/ST2/00920.

Thanks to the **ACTS** society for support with configuration of the environment.