

Introduction

Future Higgs Factory: Circular Electron Positron Collider (CEPC)

- Boson Mass Resolution (BMR) 3%~4%: stringent requirements on calorimeters

Novel high-granularity crystal ECAL: orthogonally arranged crystal bars

- 5D calorimetry, optimal EM energy resolution $\sim 3\%/\sqrt{E}$
- Critical requirements on dynamic range: detecting up to $\sim 10^5$ level photons

Electronics candidate with large dynamic range: MPT2321-B

- 32-channel readout, 12-bit ADC and 20-bit TDC per channel
- Large dynamic range: nominal design value 1.8 nC
- Lab/beam experiments to study functionality/performance

Talk on high-granularity crystal ECAL: CALOR 2024 Session Future Colliders 2

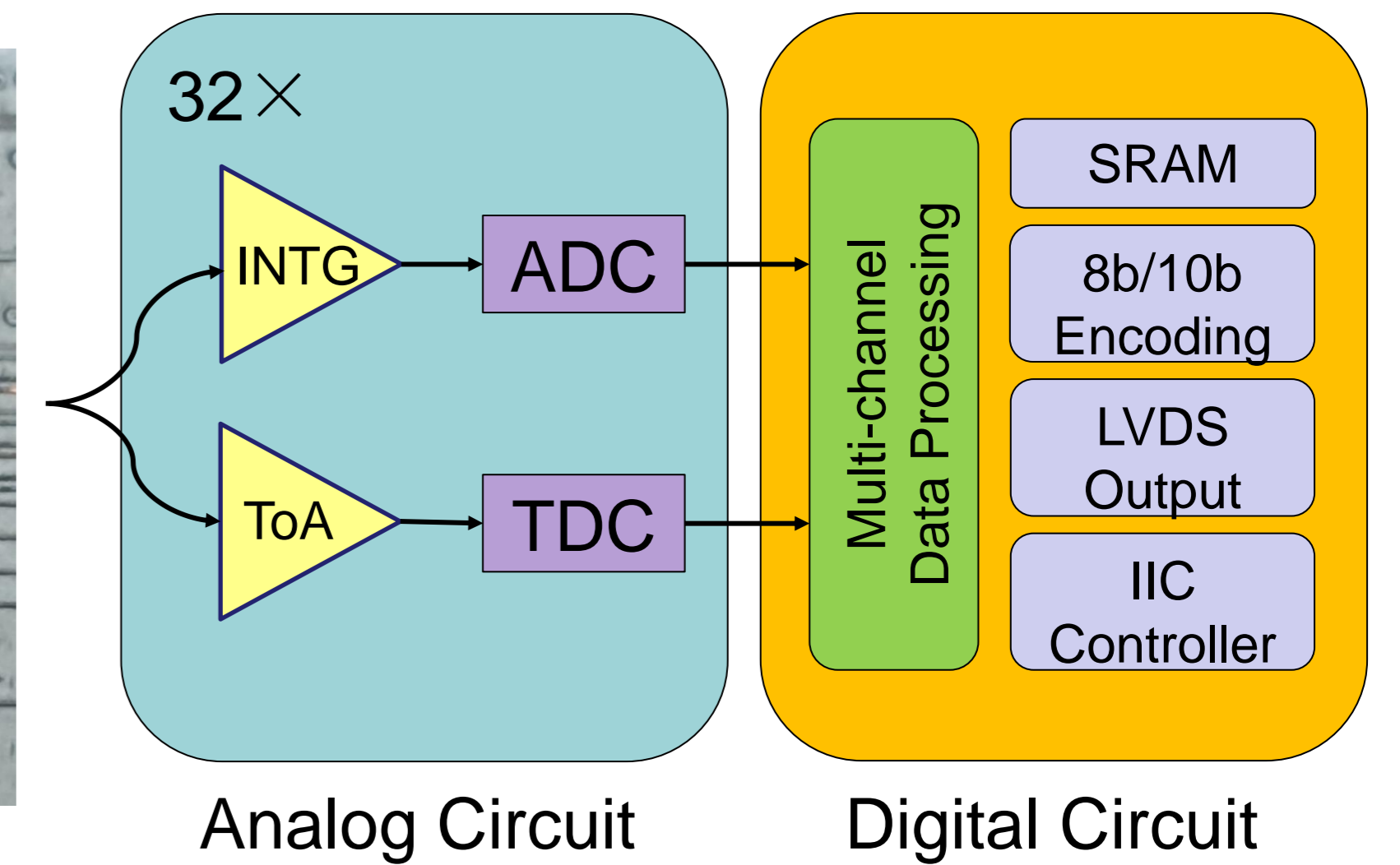
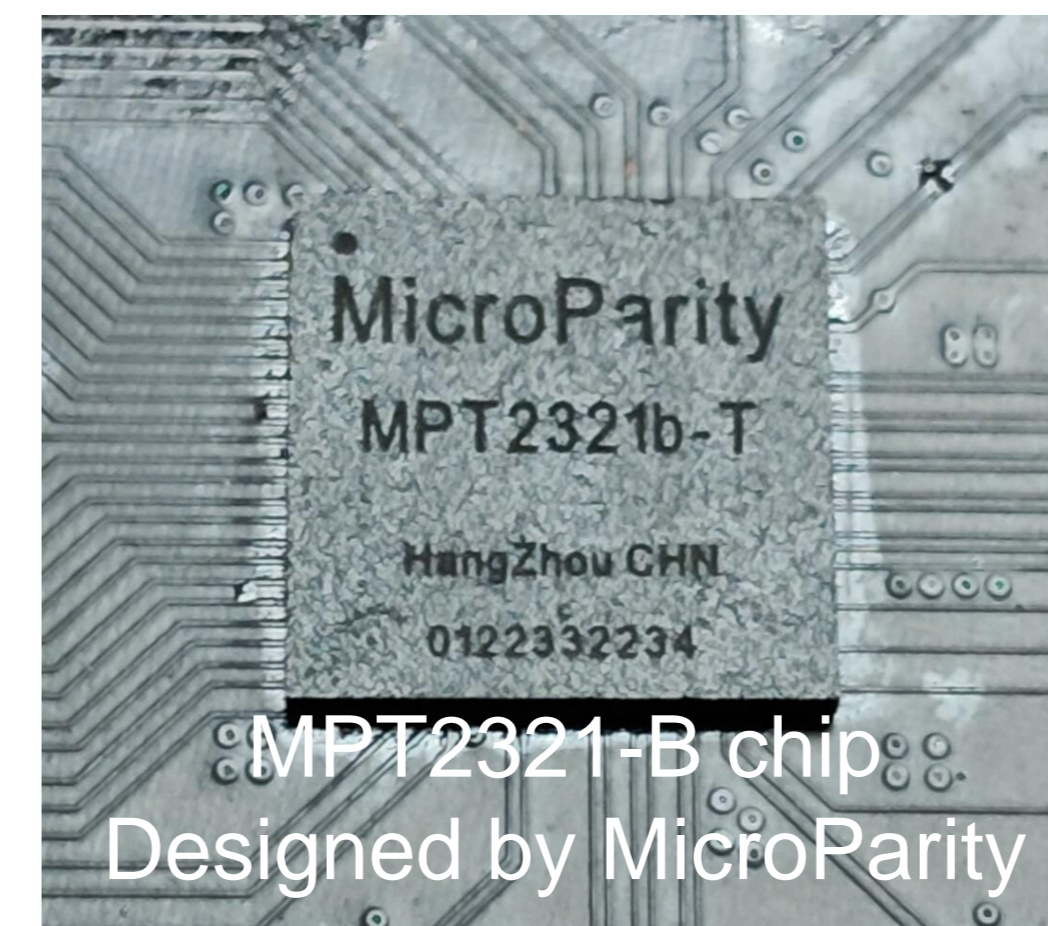

Lab Characterization

MPT-chip response linearity with charge injection

- Determining the linear range of the chip with an evaluation board
- 4 high gain modes and 4 low gain modes were tested

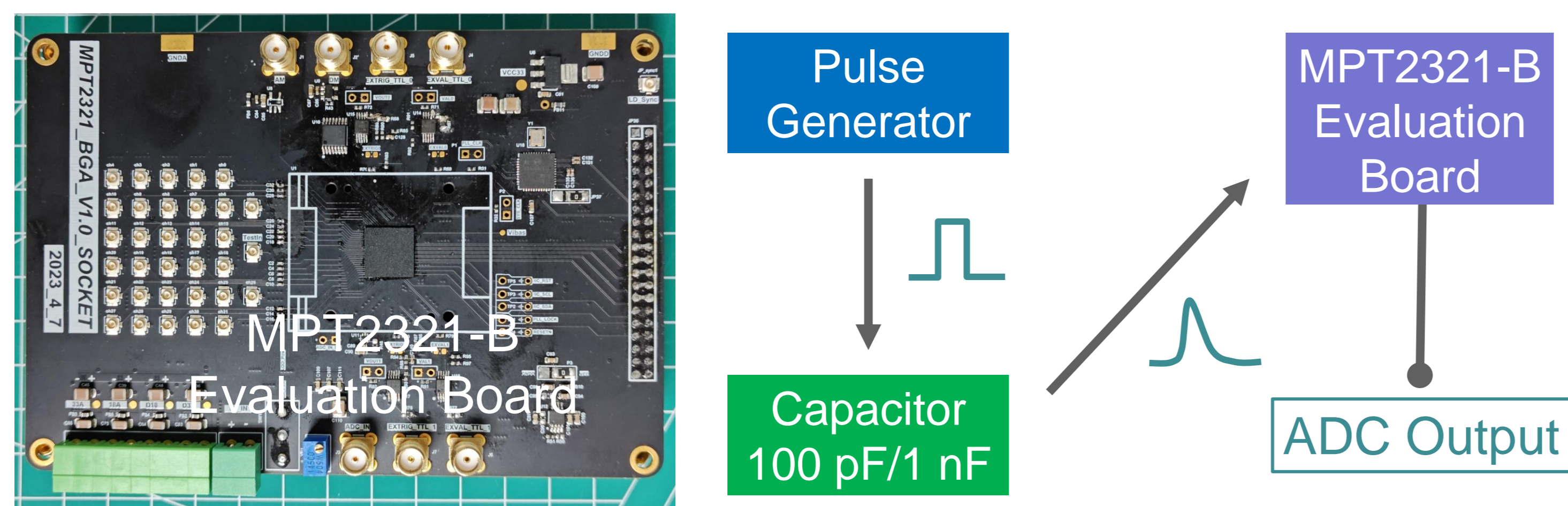

- Excellent linearity with high gain modes
- Low gain mode 4 has the largest dynamic range but also observed non-linearity effects
- With 1 nC capacitor, the maximum linear range reaches up to 1.8nC

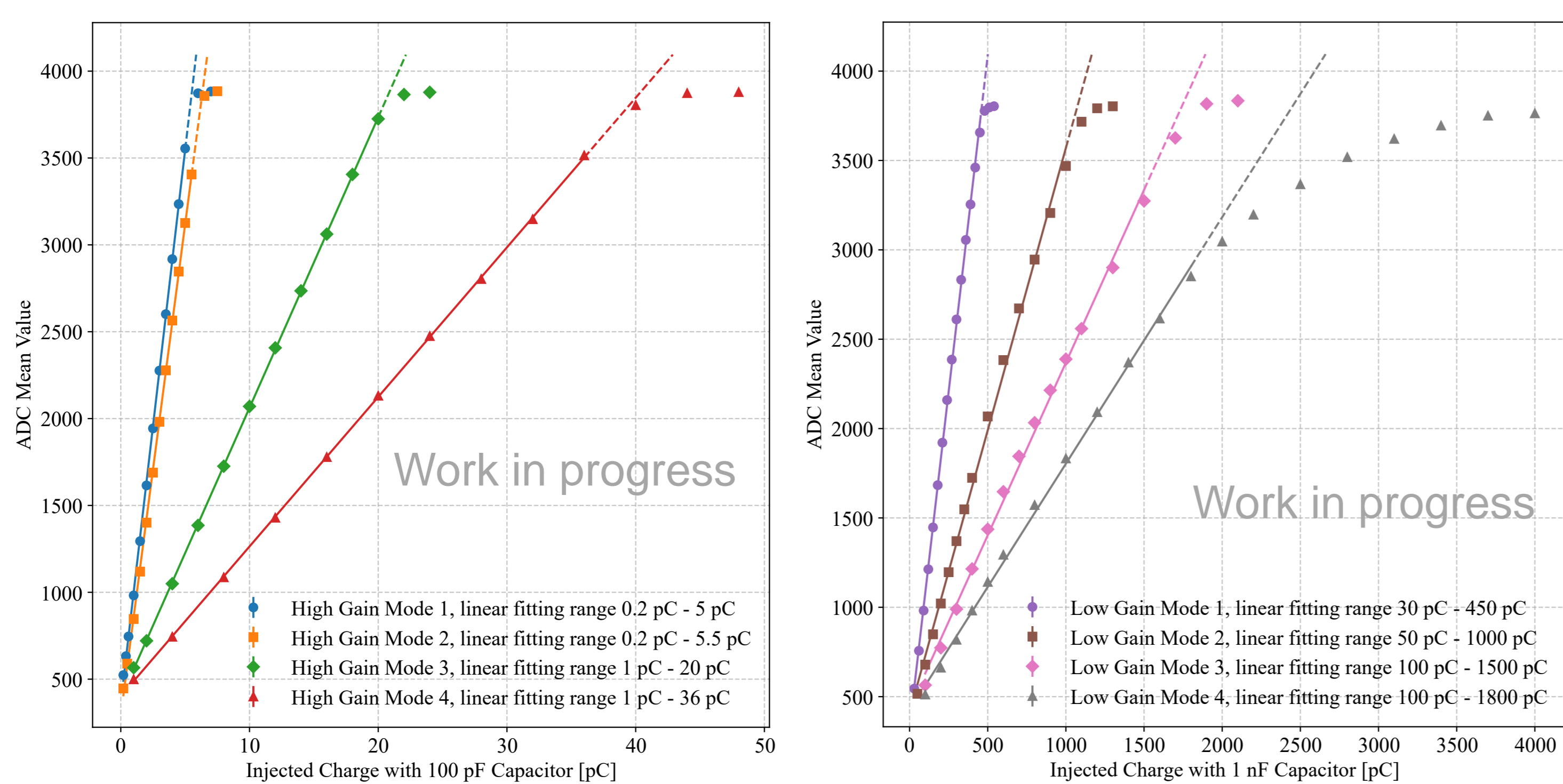

Single Photon Calibration

- LED tests with SiPMs: single-photon detection capability

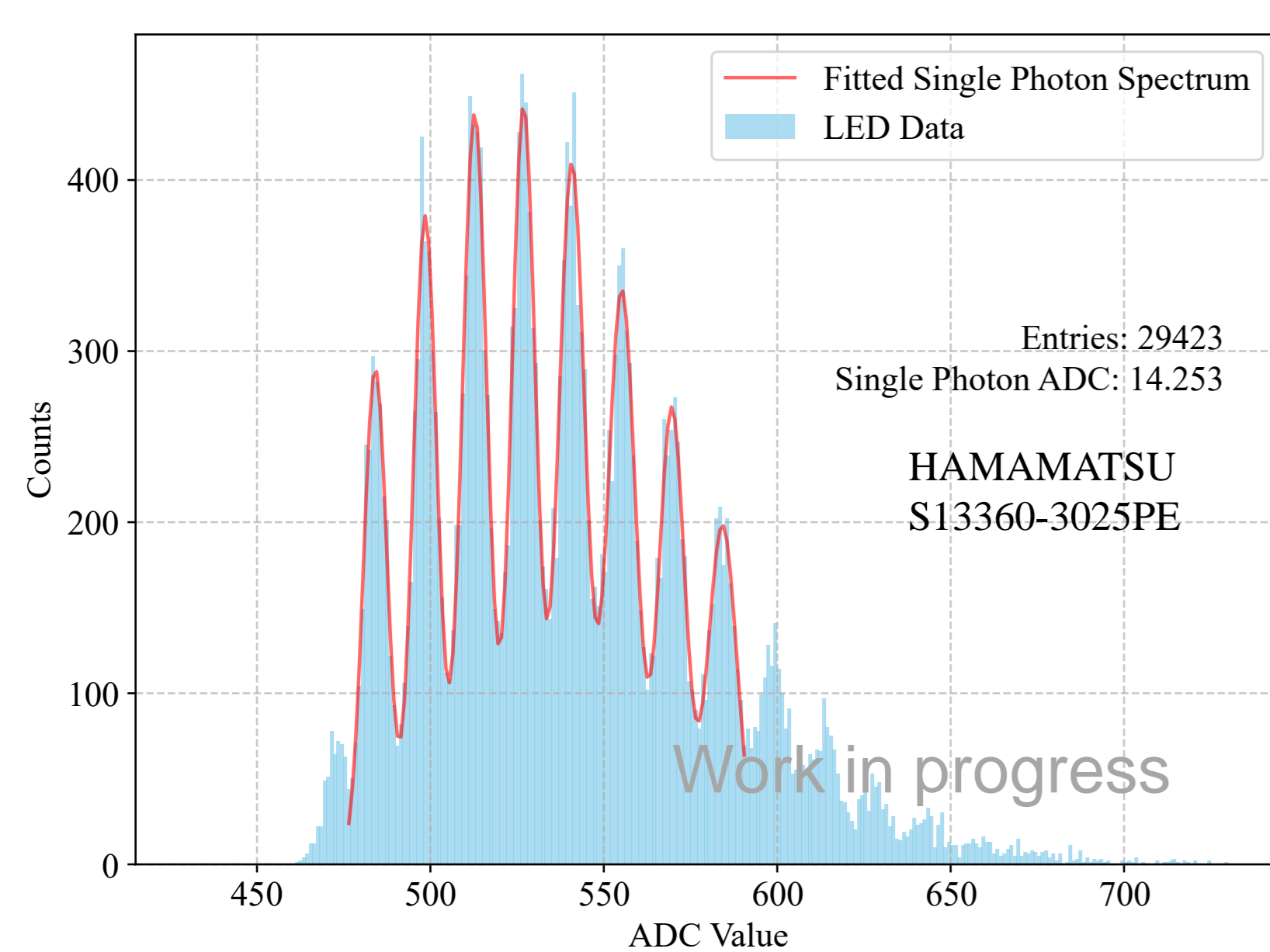

Single Photon ADC @ High Gain Mode 1

Inter-calibration constant obtained with charge injection

Single Photon ADC @ Low Gain Mode 4

Beam-test at DESY in 2023

Beam-test: first test of MPT-chip with high energy particles

- Dynamic range validation with crystal + SiPM units
- 5 GeV/c electrons hit on each one of a matrix of 4 LYSO crystals

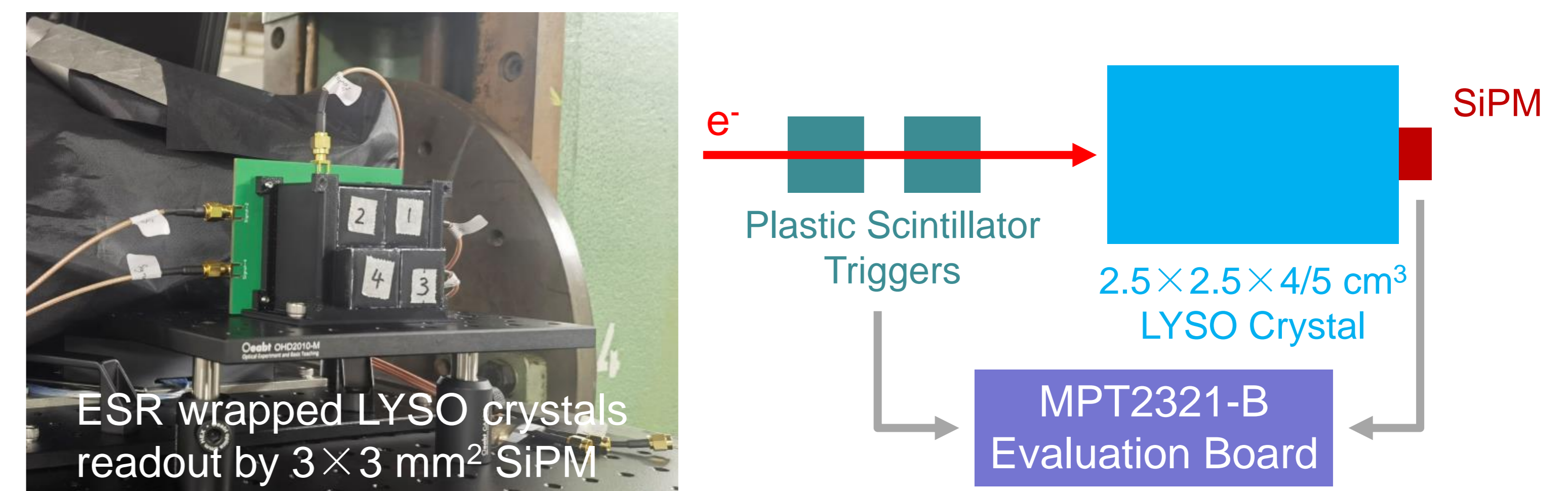

Data analysis scheme

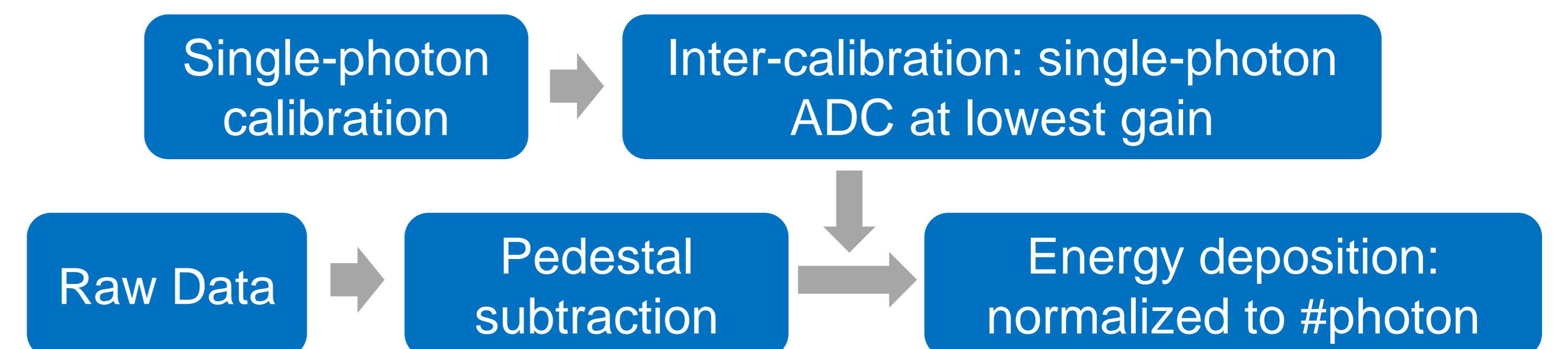

DESY beam-test results

- Electron beam response: MPV $\sim 33,000$ detected photons
 - Not reaching the plateau of the ADC value
 - Very close to the non-linear region (over 3000 ADC channel)
- Geant4 optical simulation with a similar setup
 - Detected photons $\sim 82,000$ (w/o saturation effects)
- Toy Monte Carlo for SiPM saturation modelling
 - Around 88,000 input photons for 33,000 detected photons
 - Generally consistent with the optical simulation

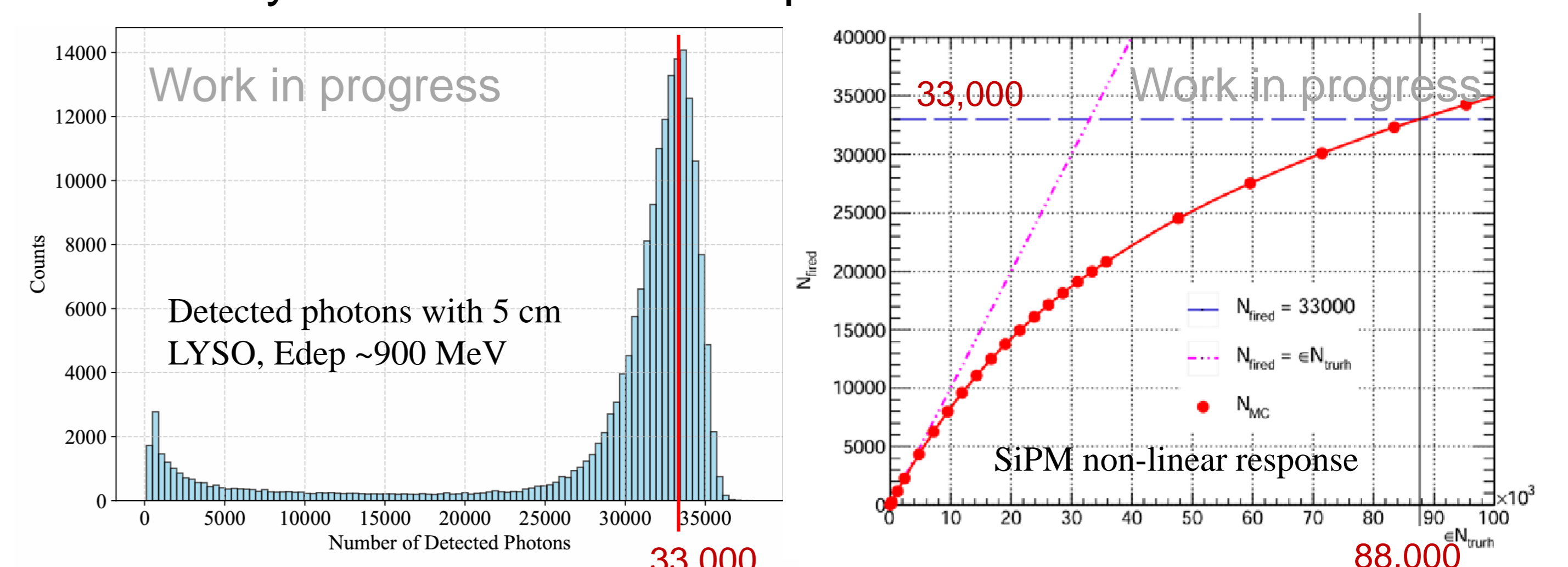

Further discussions

- For SiPMs used with 7×10^5 gain: 33,000 photons \rightarrow 3.7 nC charge
 - Note: The actual ADC is not simply equal to the input charge
 - Output depends on signal waveform, shaping time, hold-delay, etc.

Conclusions

- Successfully conducted the laboratory and beam experiments of a new SiPM readout chip
 - Demonstrated good S/N for single photon calibration
 - Capability of detecting $\sim 33,000$ photons, shows a moderately large dynamic range for SiPM readout
 - Could be improved by utilizing SiPMs with lower gains, reducing shaping time, etc.
 - New features are expected in future chip iterations

Acknowledgement

The authors would like to thank the support from the beam-test facilities at DESY and the CALICE collaboration.