

Quantum information processing with metastable states in trapped barium ions

Andres Vazquez-Brennan
10.07.2024

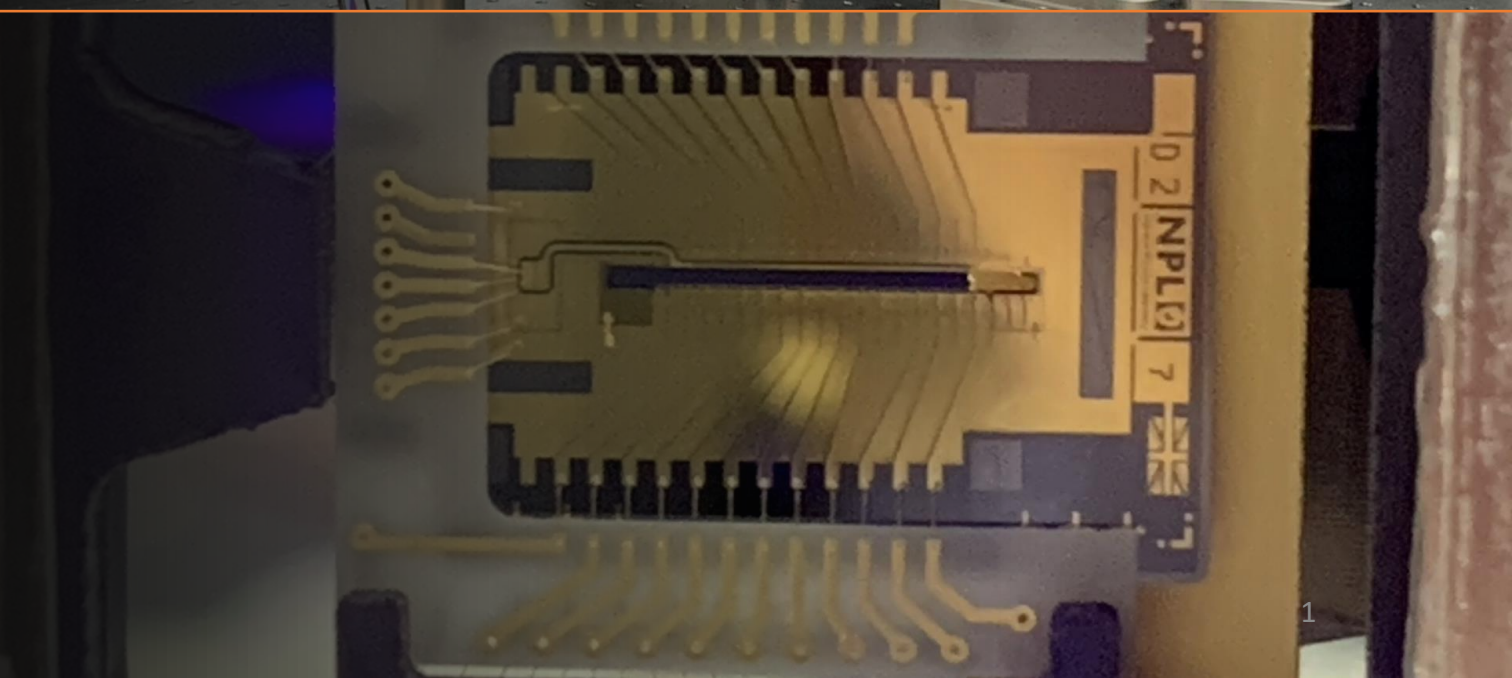

Individual addressing

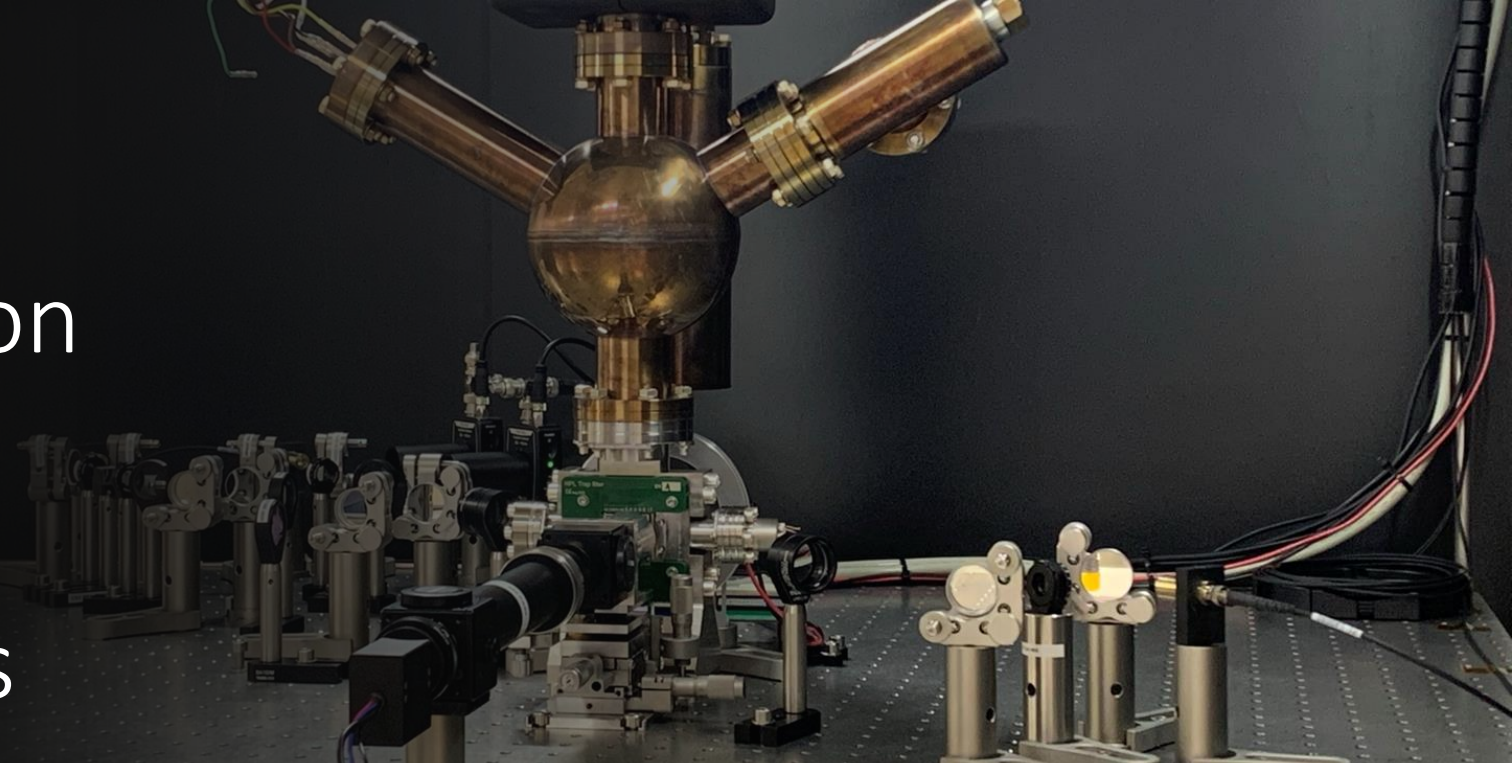
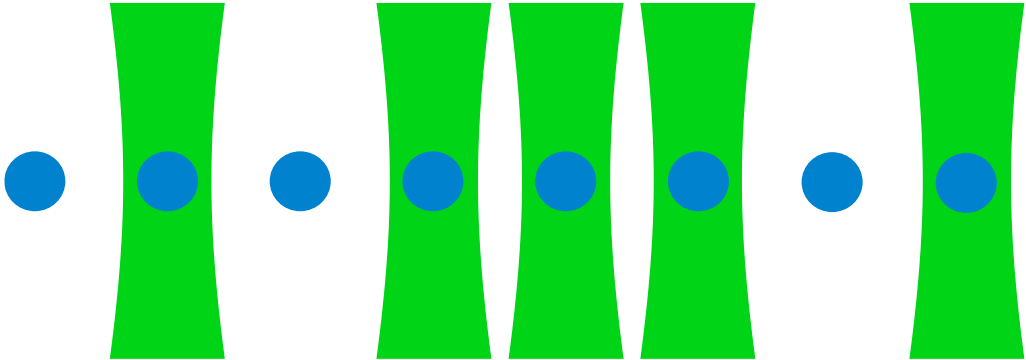

SPAM

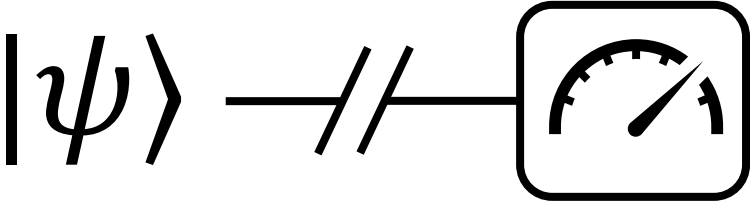

Ground

$P_{1/2}$ —————

$D_{5/2}$ —————

$S_{1/2}$ —————

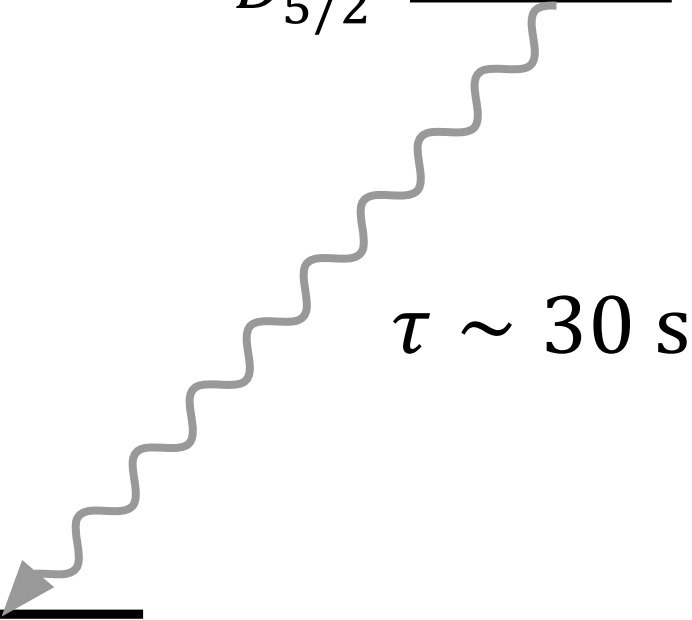

Metastable

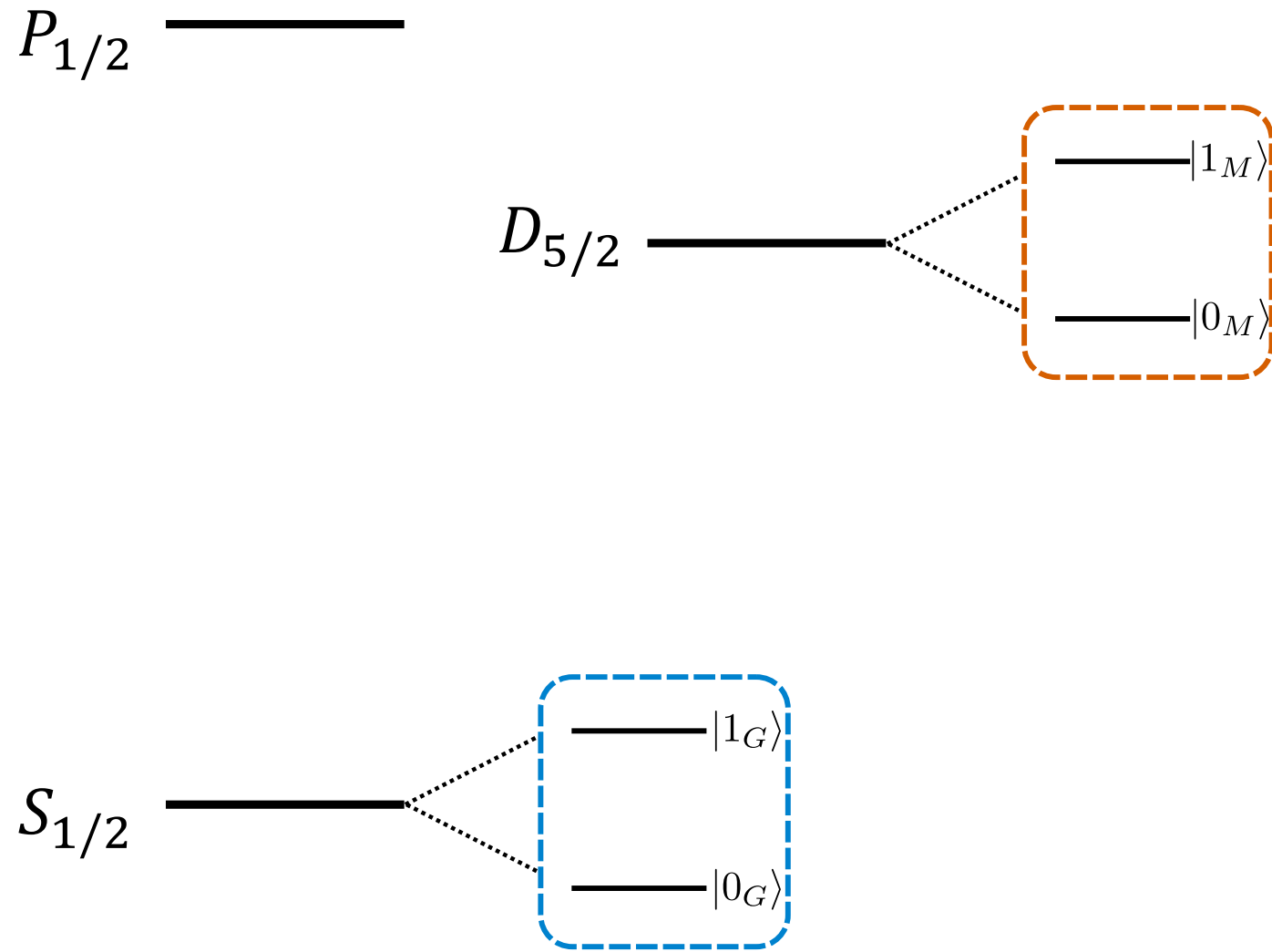

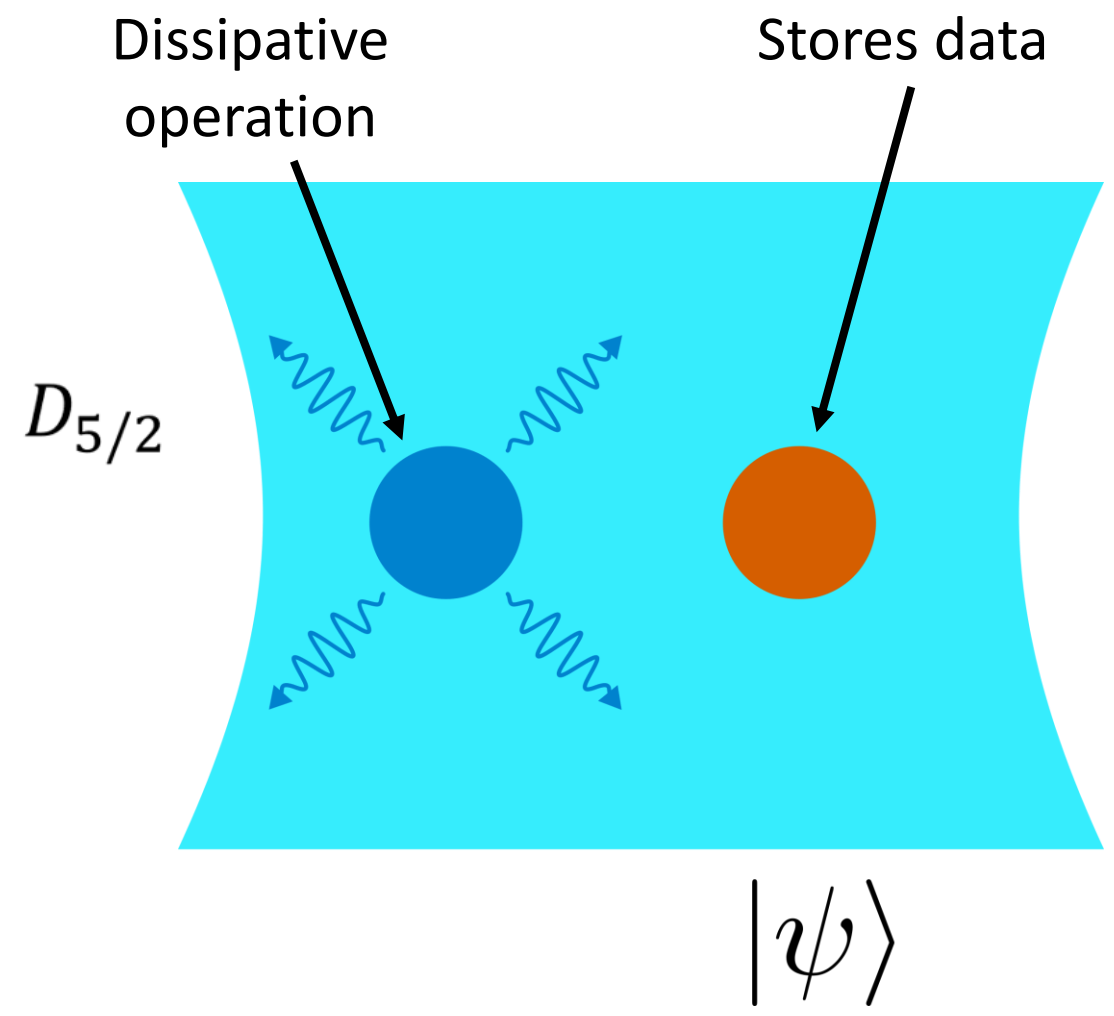
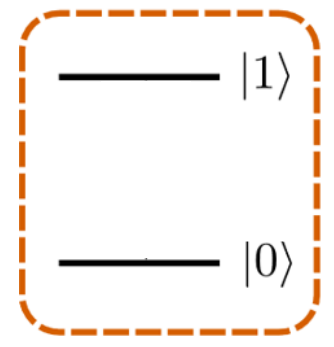
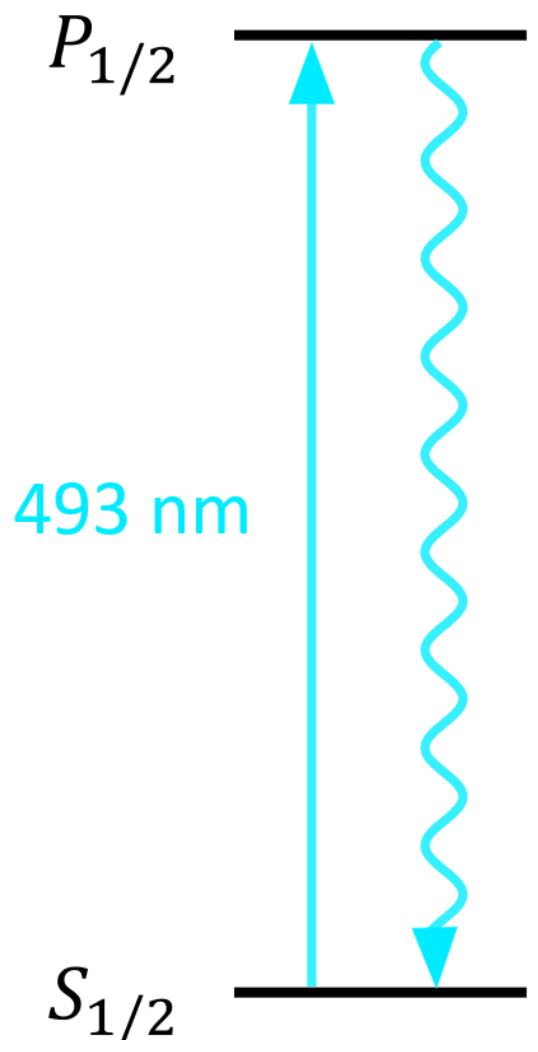

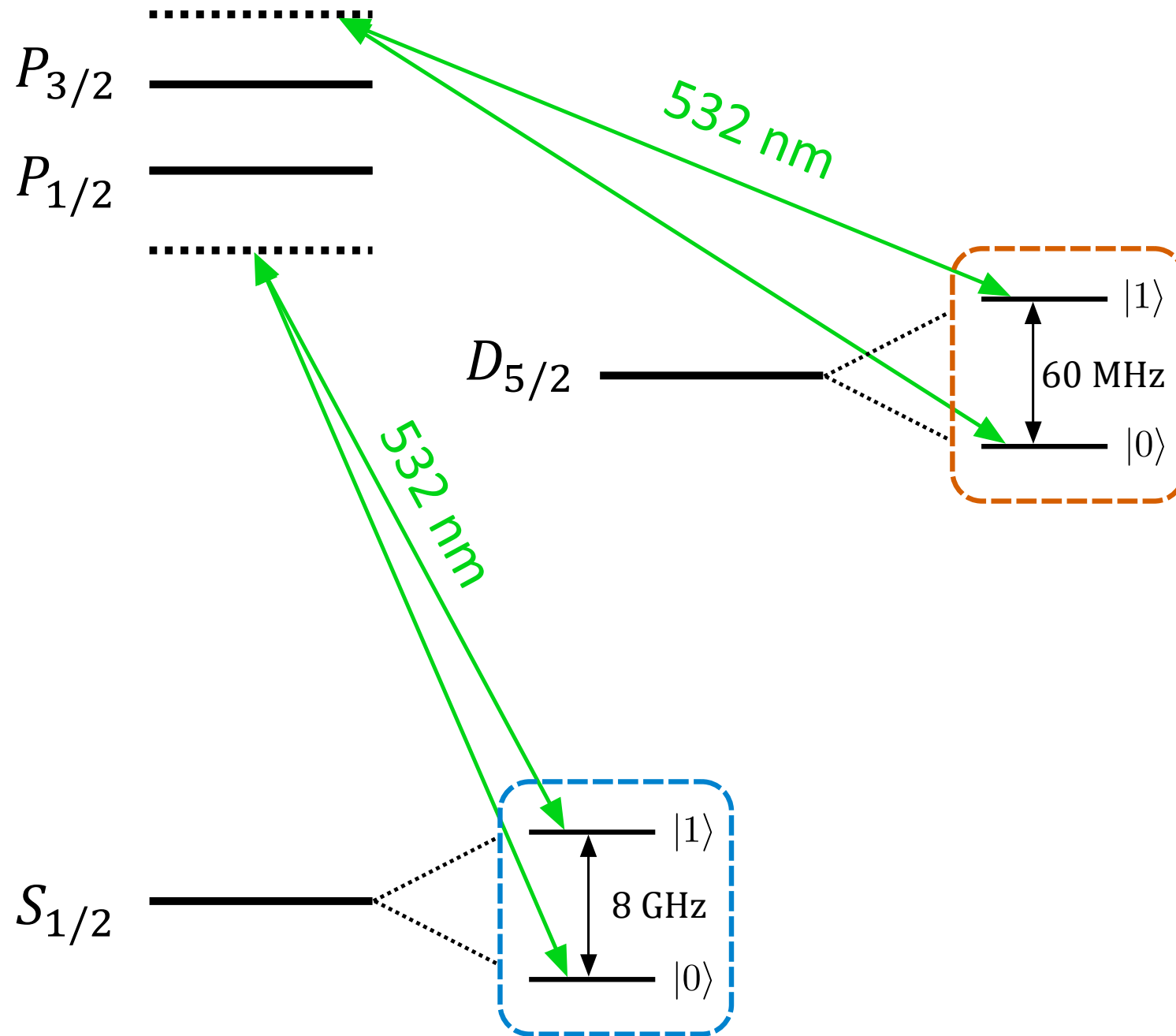

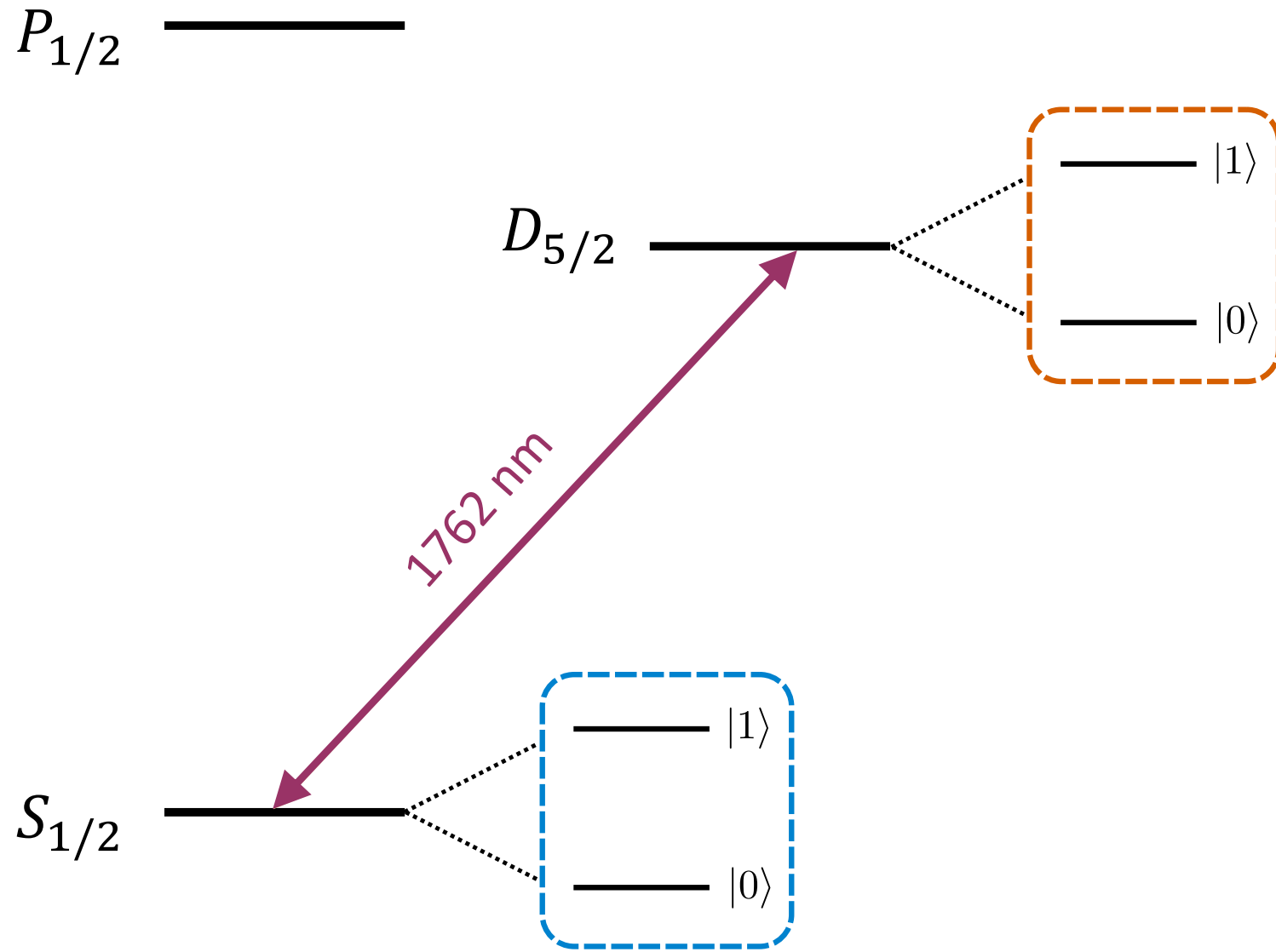

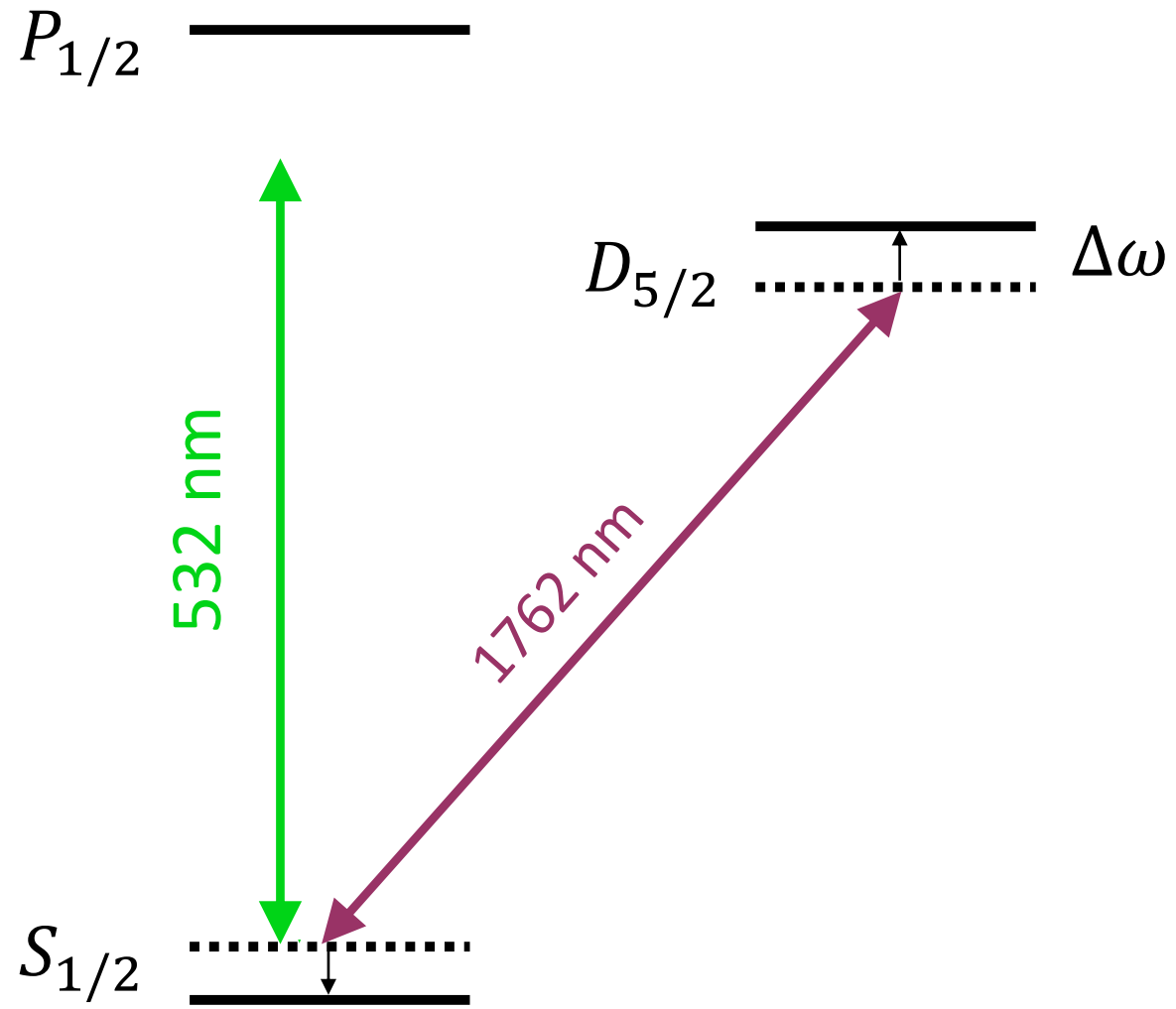

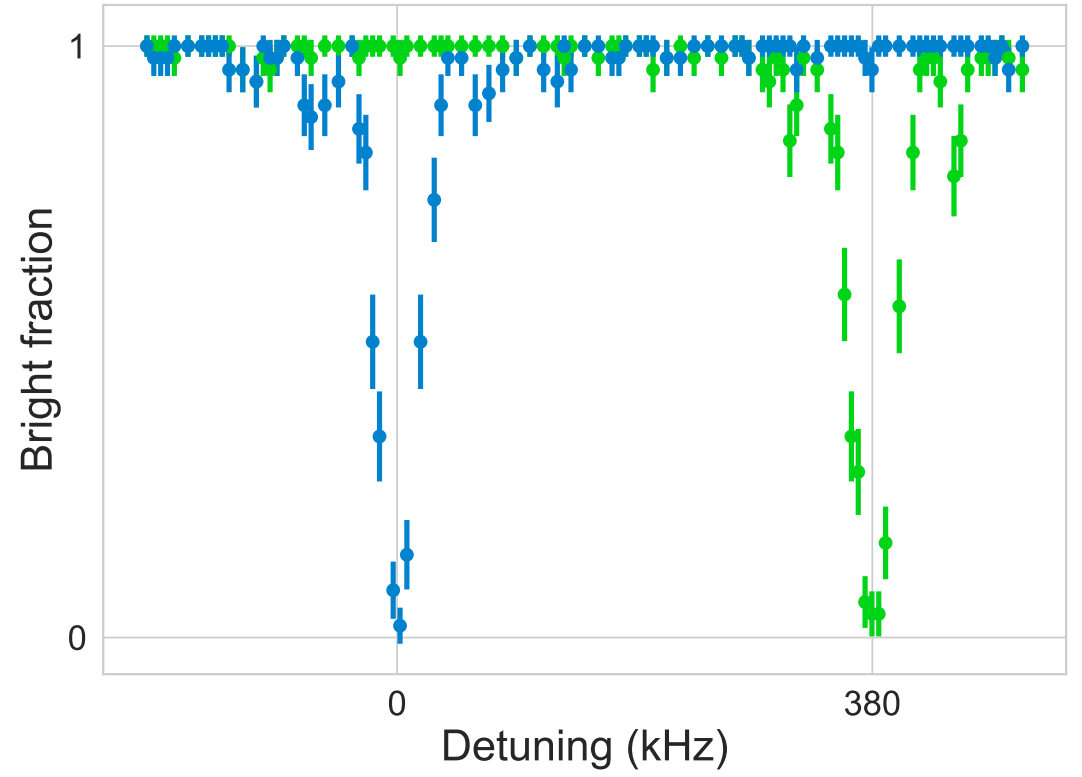
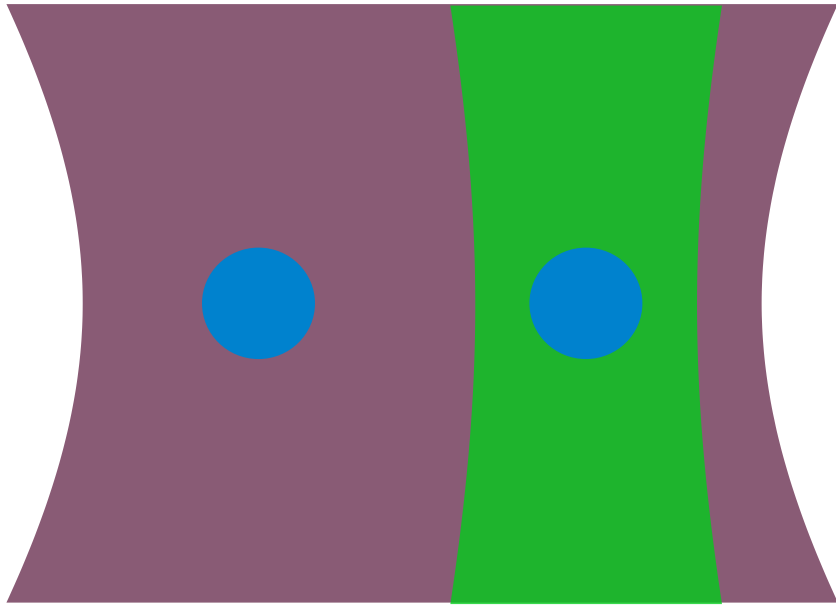

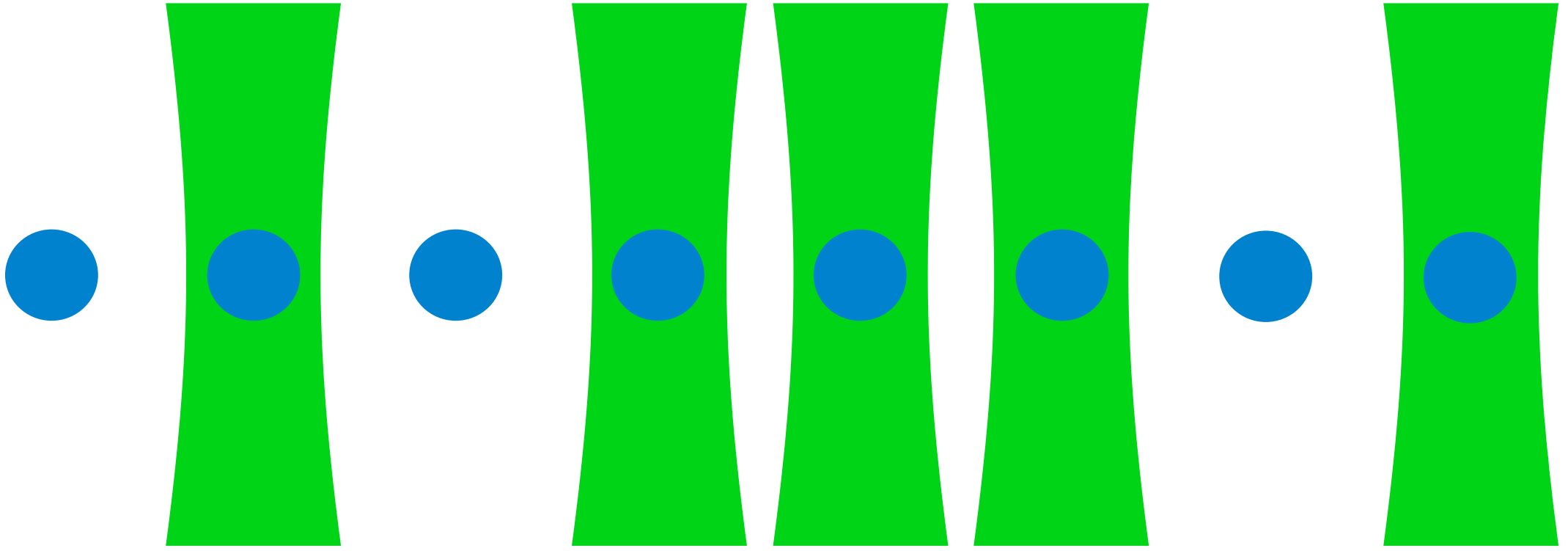

Raman
beams

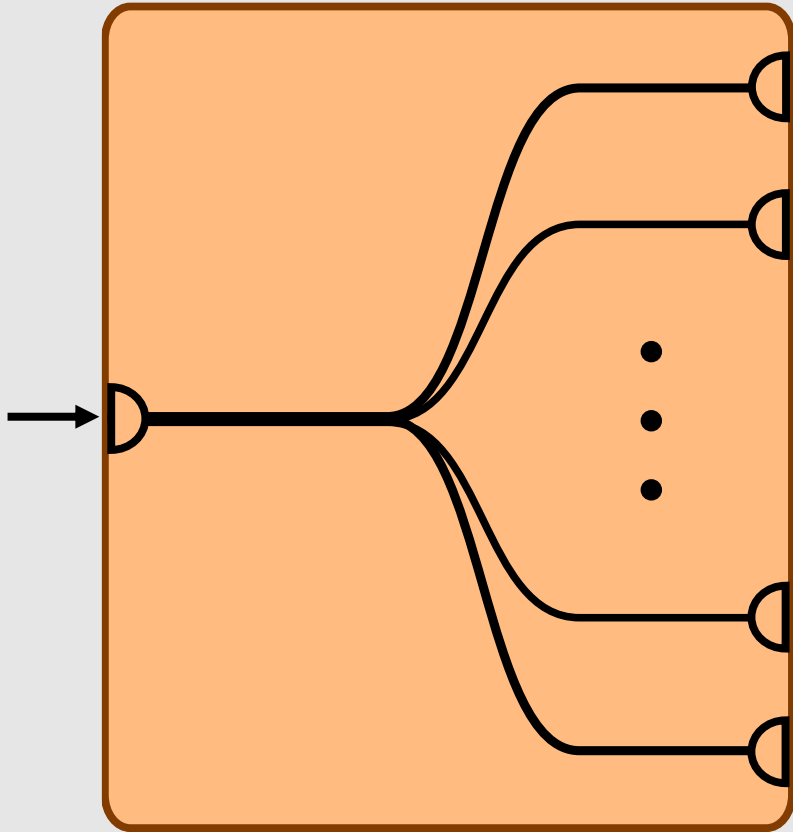

Fibre splitters



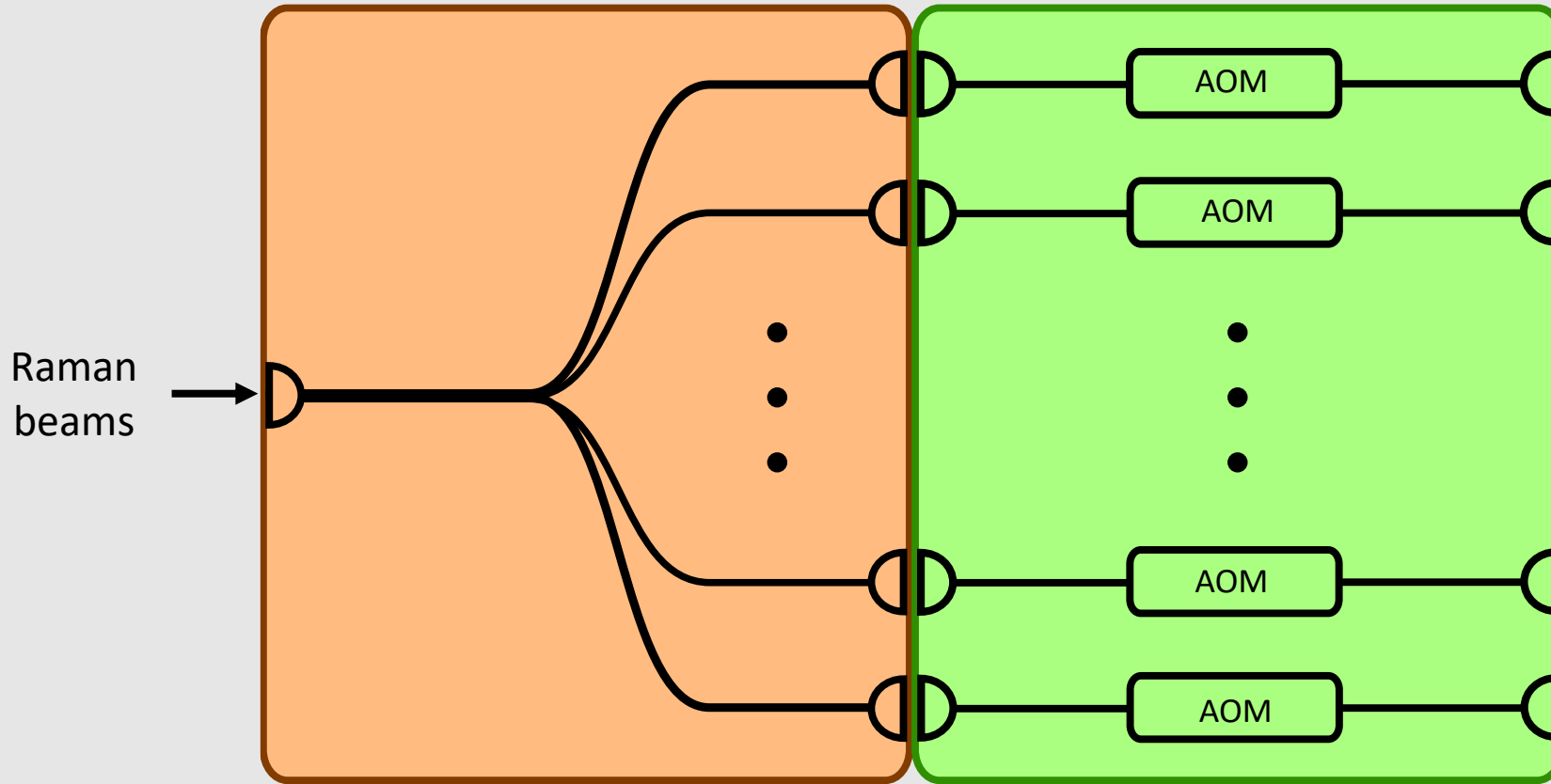

Fibre splitters



Fibre AOMs

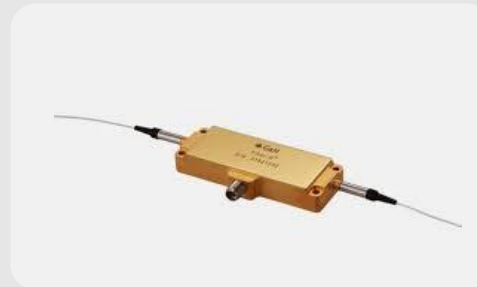

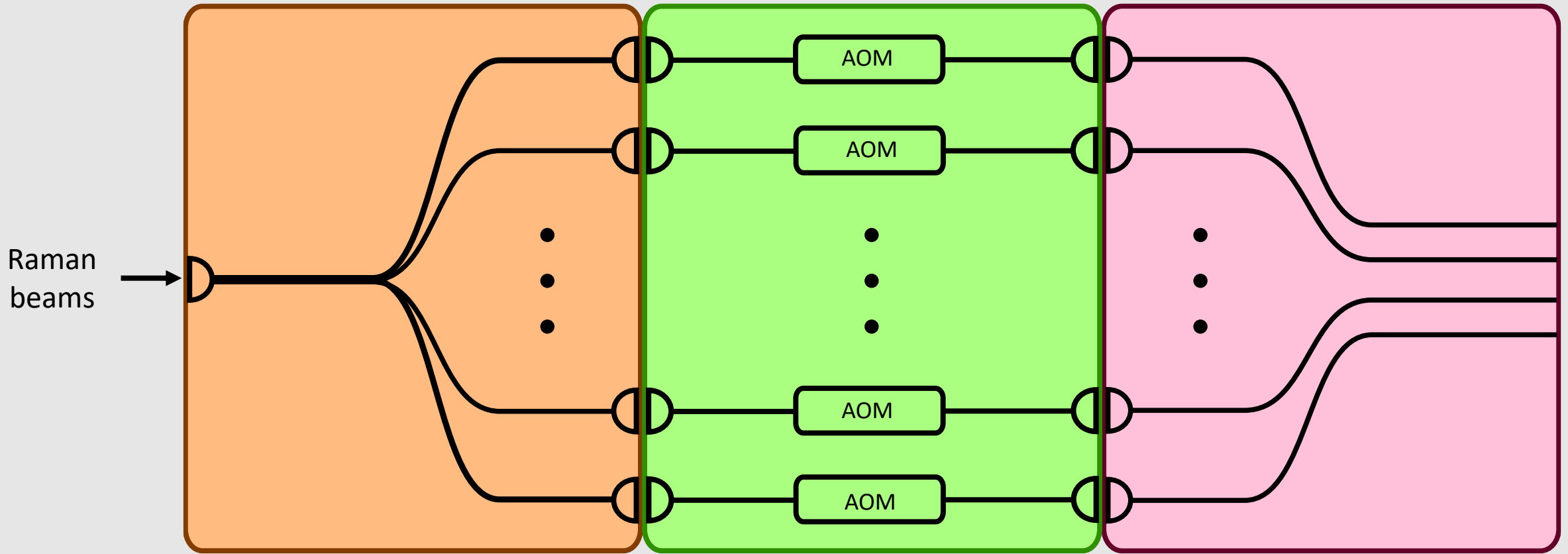

Fibre splitters



Fibre AOMs

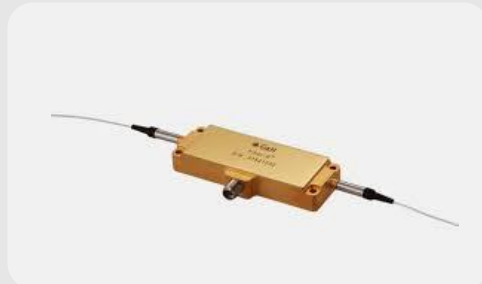

V-groove array

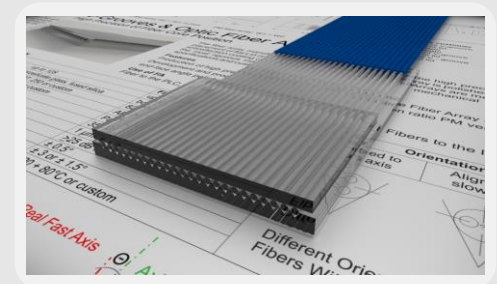

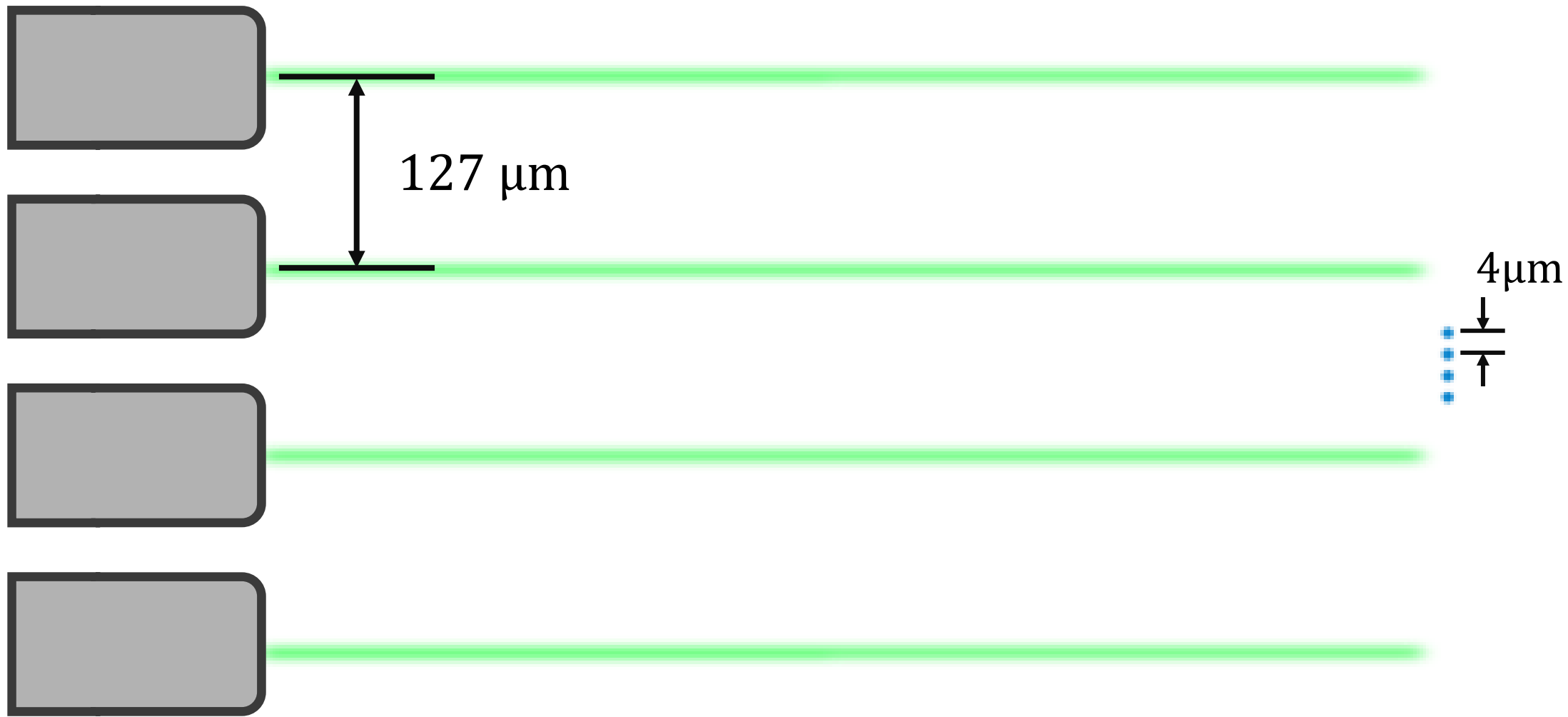

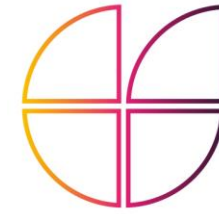

DEPARTMENT OF
**ENGINEERING
SCIENCE**

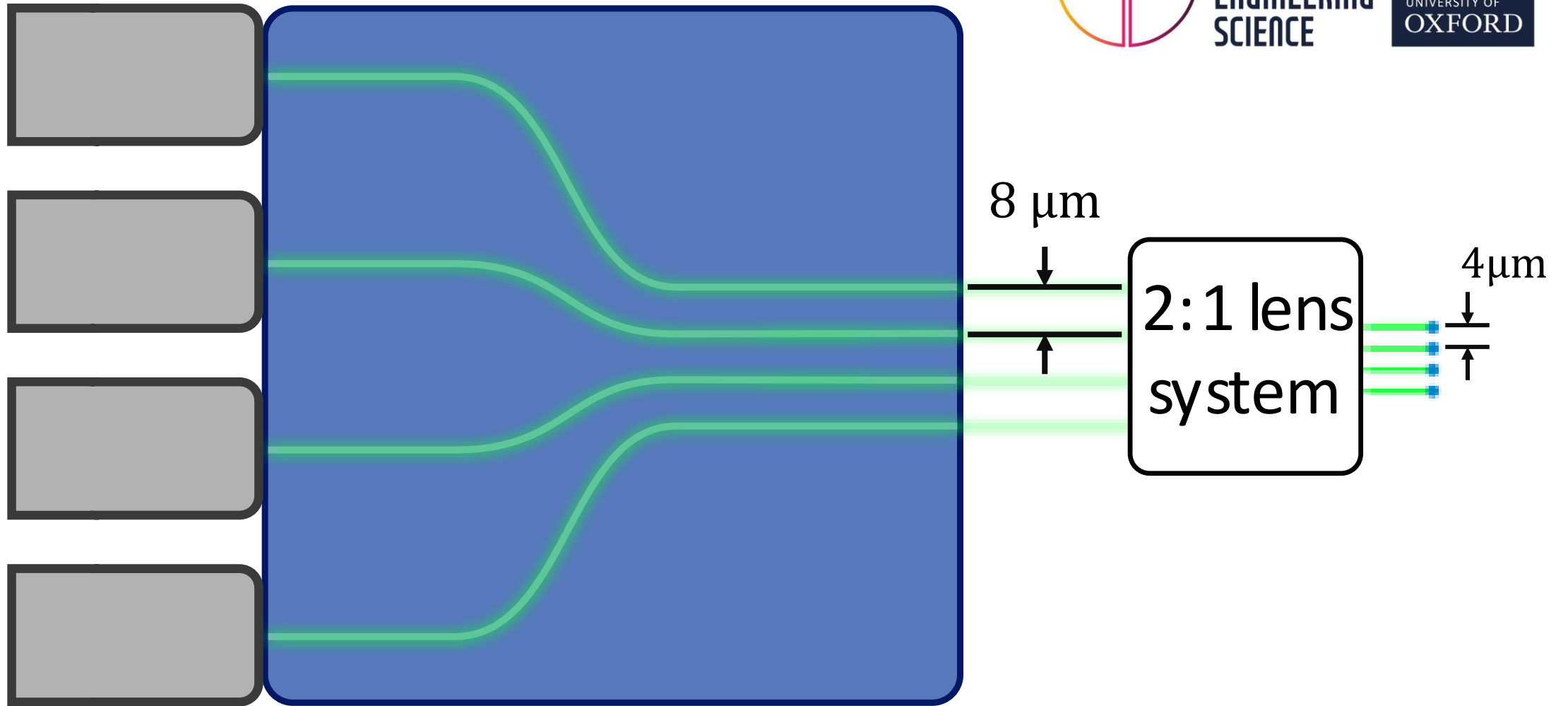

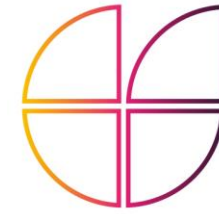

DEPARTMENT OF
**ENGINEERING
SCIENCE**

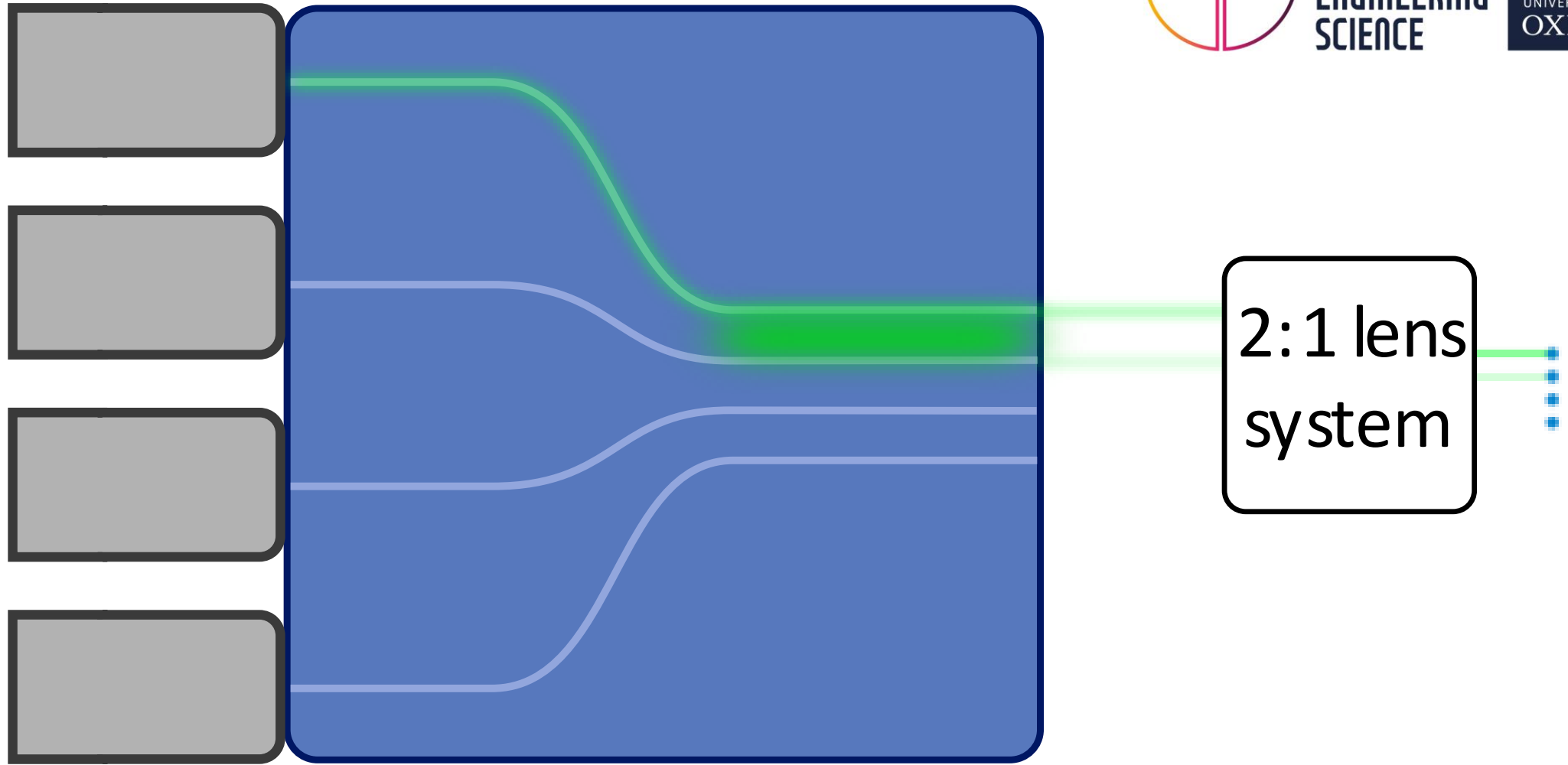

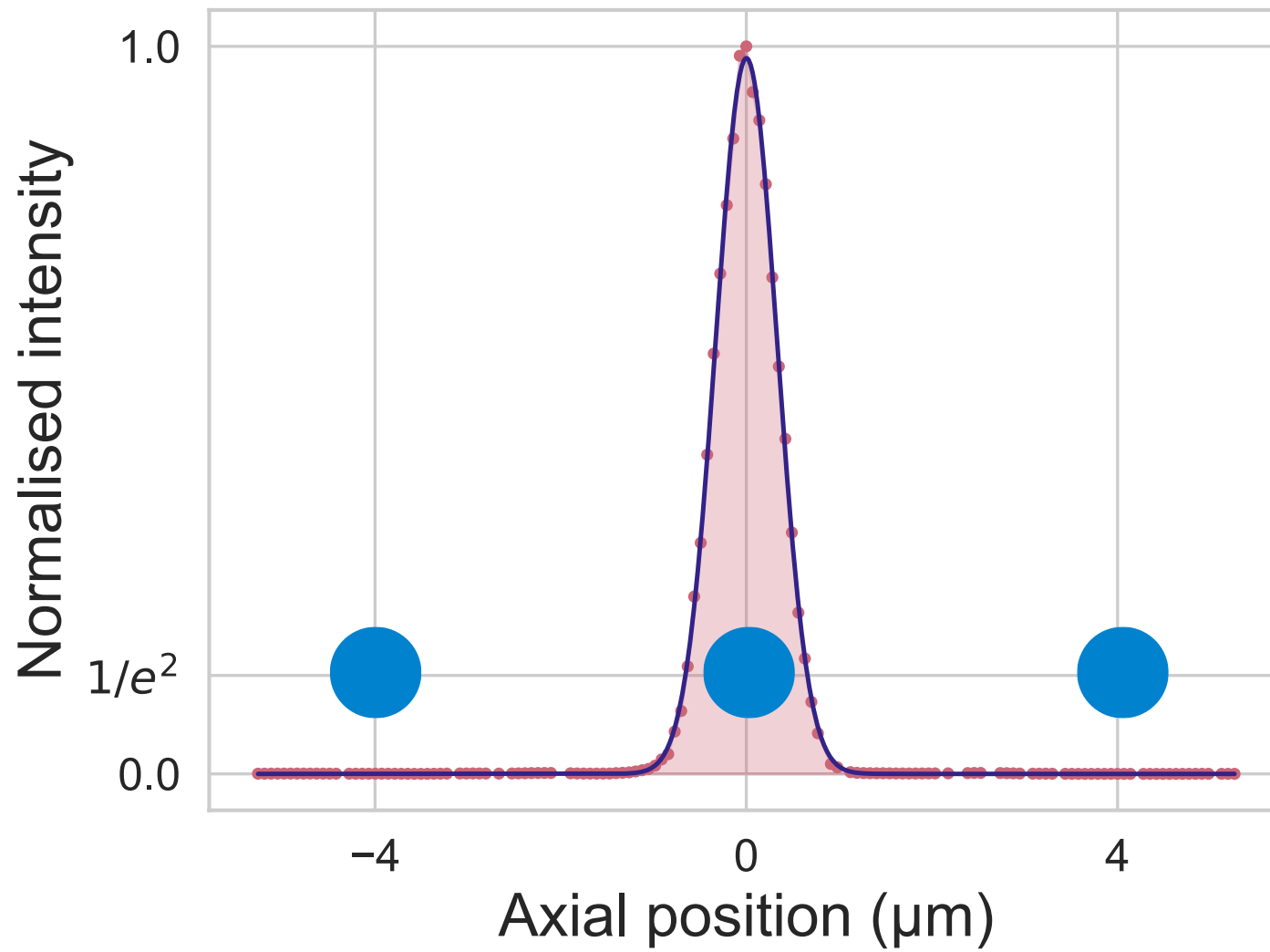

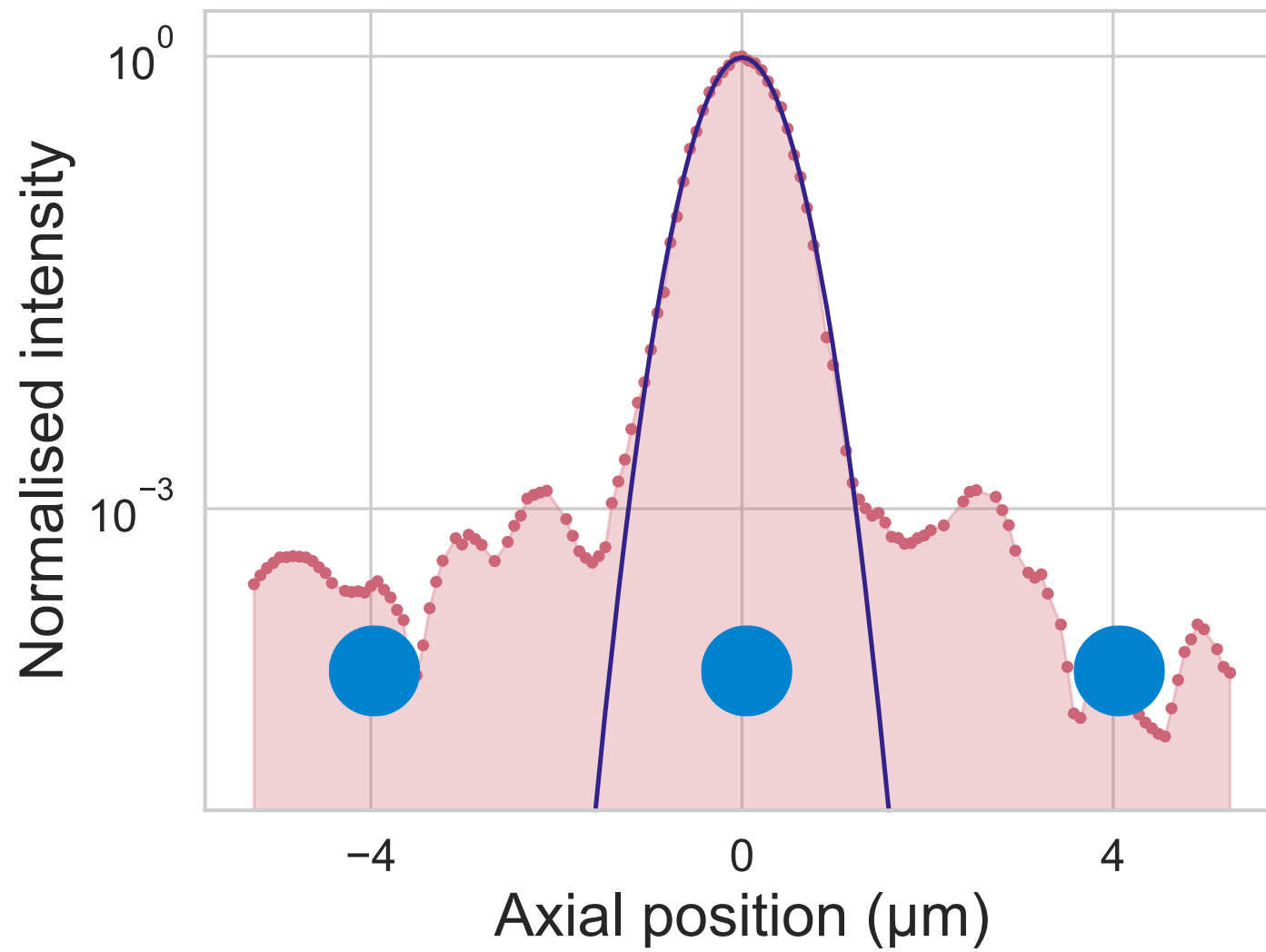

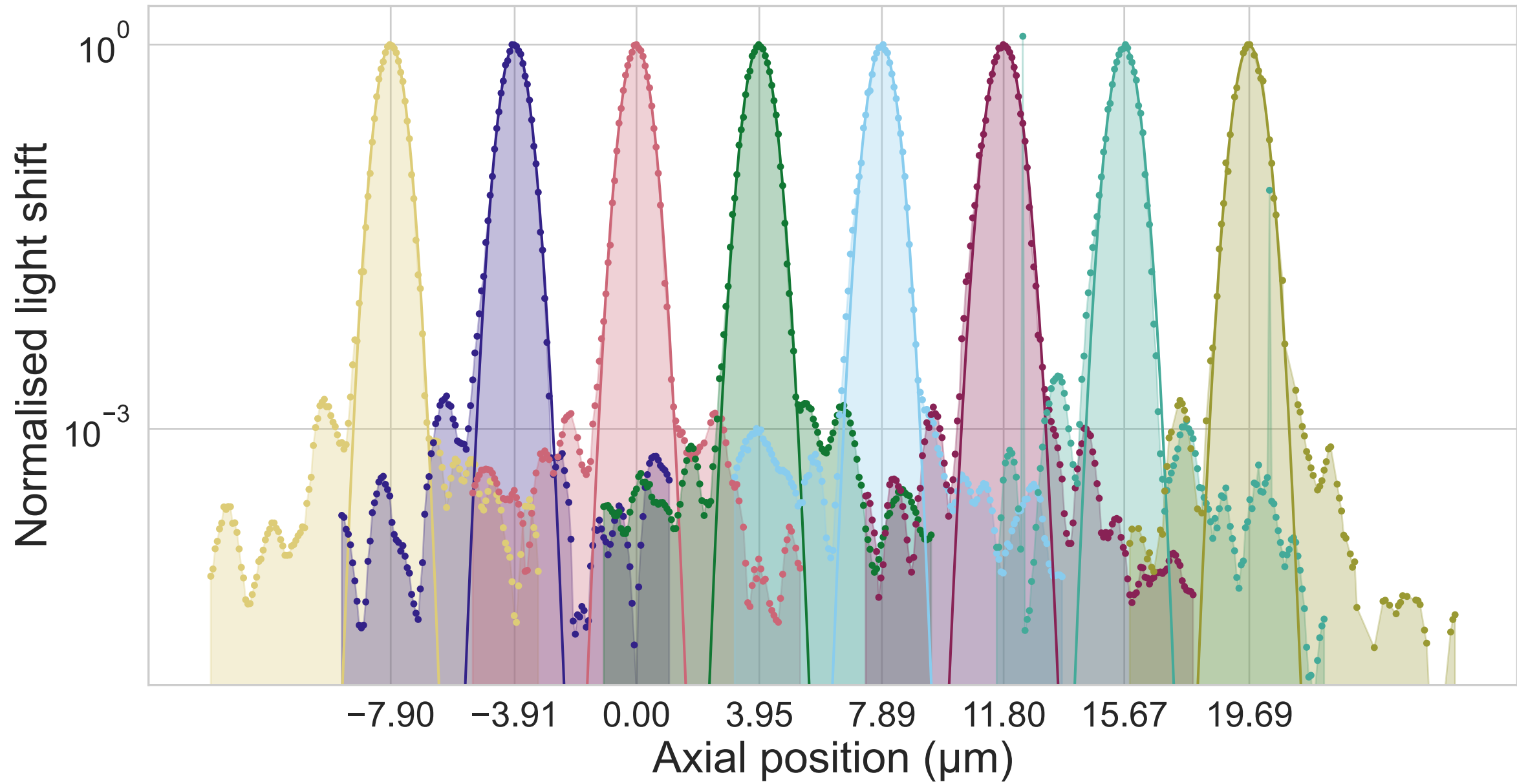

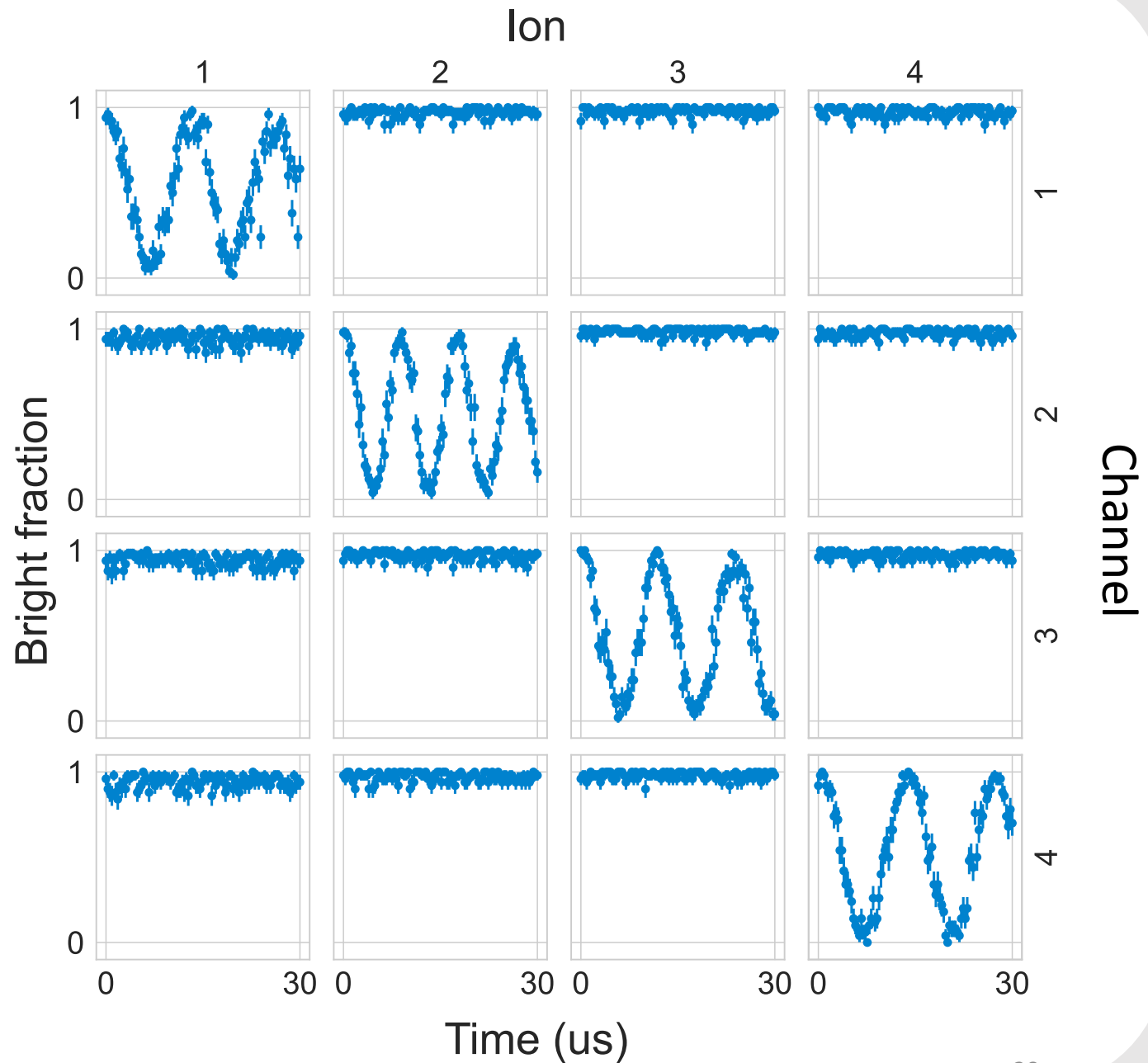
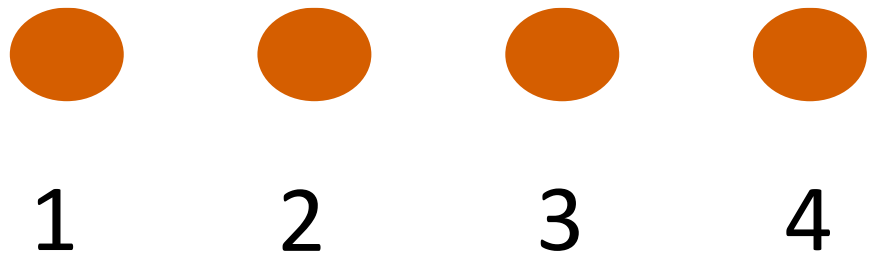

State
Prep

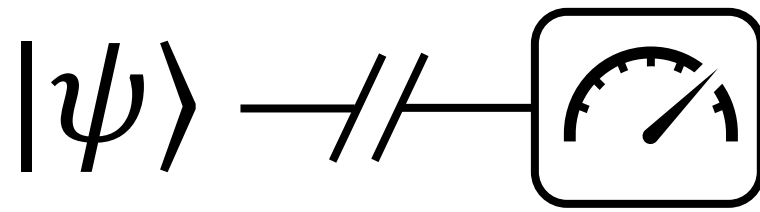

Measurement

And



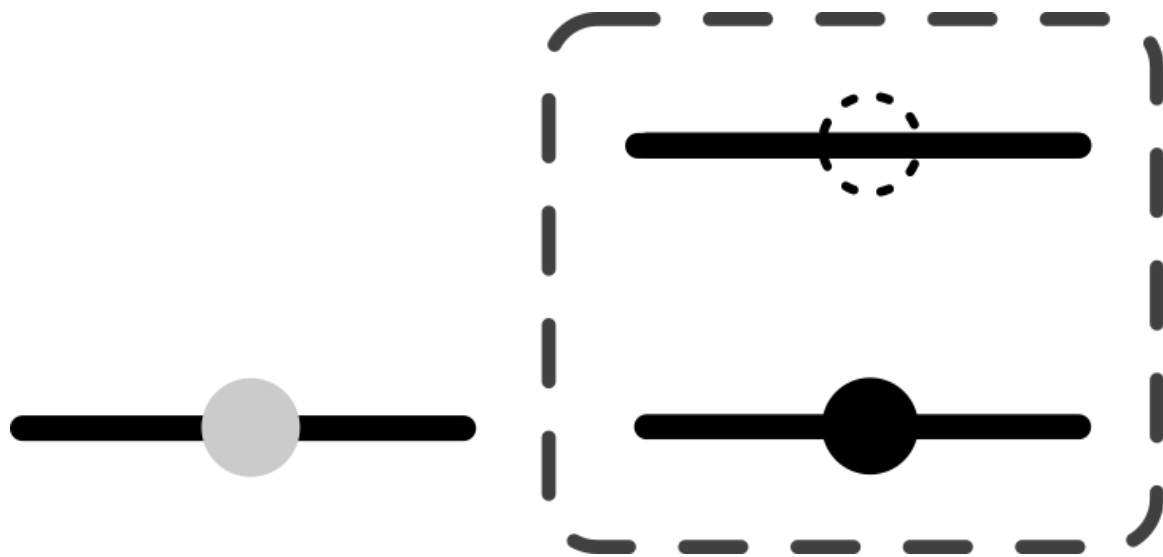

$|\psi\rangle$

[nature](#) > [npj quantum information](#) > [articles](#) > [article](#)

Article | [Open access](#) | [Published: 14 December 2020](#)

Leakage detection for a transmon-based surface code

[Boris Mihailov Varbanov](#) , [Francesco Battistel](#), [Brian Michael Tarasinski](#), [Viacheslav Petrovych Ostroukh](#), [Thomas Eugene O'Brien](#), [Leonardo DiCarlo](#) & [Barbara Maria Terhal](#)

[npj Quantum Information](#) **6**, Article number: 102 (2020) | [Cite this article](#)

3228 Accesses | 24 Citations | 4 Altmetric | [Metrics](#)

[nature](#) > [nature communications](#) > [articles](#) > [article](#)

Article | [Open access](#) | [Published: 09 August 2022](#)

Erasure conversion for fault-tolerant quantum computing in alkaline earth Rydberg atom arrays

[Yue Wu](#), [Shimon Kolkowitz](#), [Shruti Puri](#) & [Jeff D. Thompson](#) 

[Nature Communications](#) **13**, Article number: 4657 (2022) | [Cite this article](#)

10k Accesses | 34 Citations | 121 Altmetric | [Metrics](#)

PHYSICAL REVIEW X **13**, 041022 (2023)

Erasure Qubits: Overcoming the T_1 Limit in Superconducting Circuits

[Aleksander Kubica](#) , ^{1,2,*} [Arbel Haim](#), ^{1,3,*} [Yotam Vaknin](#) , ^{1,4,*} [Harry Levine](#), ¹ [Fernando Brandão](#), ^{1,2} and [Alex Retzker](#) ^{1,2,4}

¹AWS Center for Quantum Computing, Pasadena, California 91125, USA

²California Institute of Technology, Pasadena, California 91125, USA

³Institute of Applied Physics, The Hebrew University of Jerusalem, Jerusalem 91904, Givat Ram, Israel

⁴Racah Institute of Physics, The Hebrew University of Jerusalem, Jerusalem 91904, Givat Ram, Israel

 (Received 15 August 2022; revised 2 July 2023; accepted 30 August 2023; published 1 November 2023)

PRX QUANTUM **4**, 020358 (2023)

Quantum Error Correction with Metastable States of Trapped Ions Using Erasure Conversion

[Mingyu Kang](#) , ^{1,2,*} [Wesley C. Campbell](#), ^{3,4,5} and [Kenneth R. Brown](#) ^{1,2,6,7,†}

¹Duke Quantum Center, Duke University, Durham, North Carolina 27701, USA

²Department of Physics, Duke University, Durham, North Carolina 27708, USA

³Department of Physics and Astronomy, University of California, Los Angeles, California 90095, USA

⁴Challenge Institute for Quantum Computation, University of California, Los Angeles, California 90095, USA

⁵Center for Quantum Science and Engineering, University of California, Los Angeles, California 90095, USA

⁶Department of Electrical and Computer Engineering, Duke University, Durham, North Carolina 27708, USA

⁷Department of Chemistry, Duke University, Durham, North Carolina 27708, USA

 (Received 15 November 2022; revised 12 March 2023; accepted 15 May 2023; published 30 June 2023)

[nature](#) > [nature physics](#) > [letters](#) > [article](#)

Letter | [Published: 01 August 2022](#)

Realizing coherently convertible dual-type qubits with the same ion species

[H.-X. Yang](#), [J.-Y. Ma](#), [Y.-K. Wu](#), [Y. Wang](#), [M.-M. Cao](#), [W.-X. Guo](#), [Y.-Y. Huang](#), [L. Feng](#), [Z.-C. Zhou](#) & [L.-M. Duan](#)

[Nature Physics](#) **18**, 1058–1061 (2022) | [Cite this article](#)

2421 Accesses | 15 Citations | 33 Altmetric | [Metrics](#)

State Prep

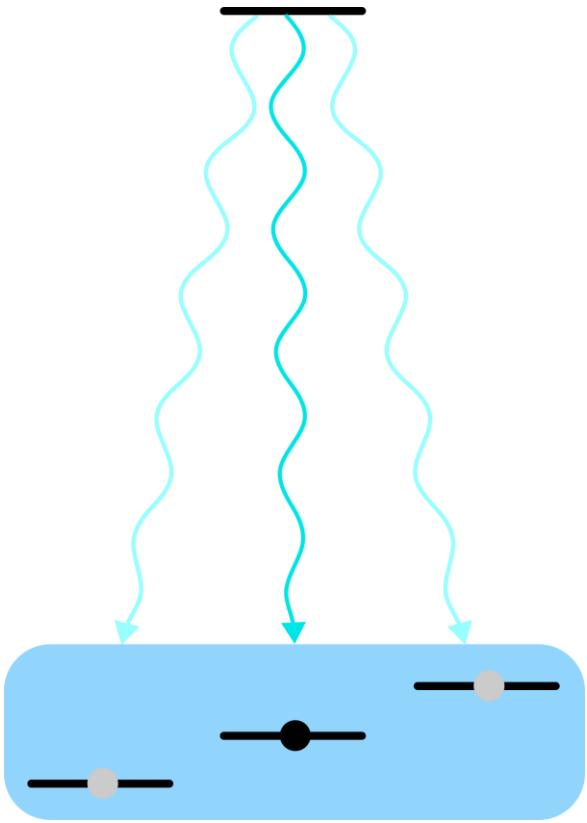

Measurement

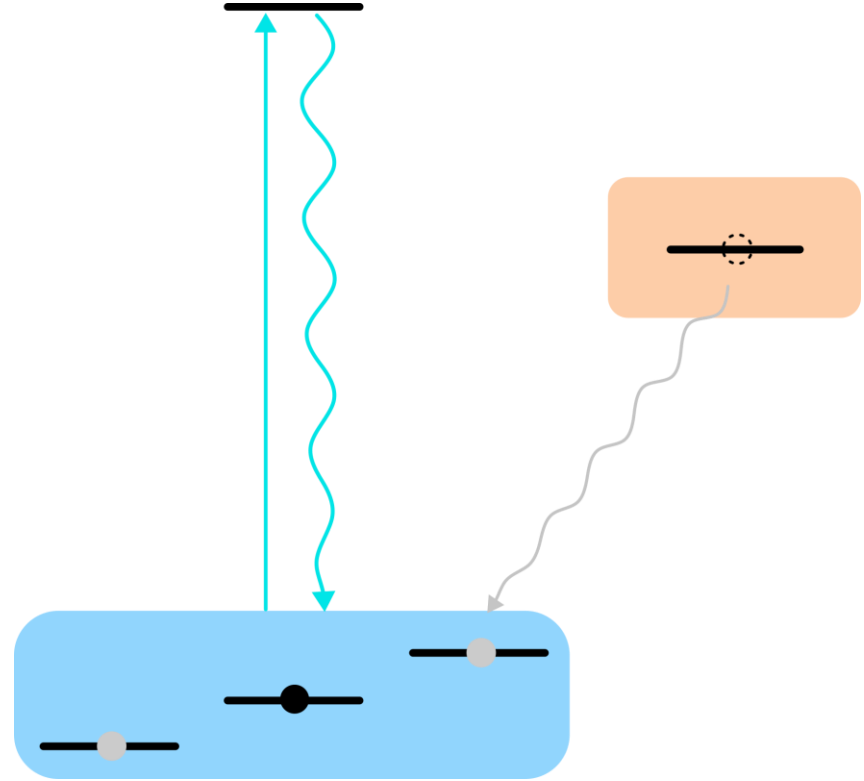

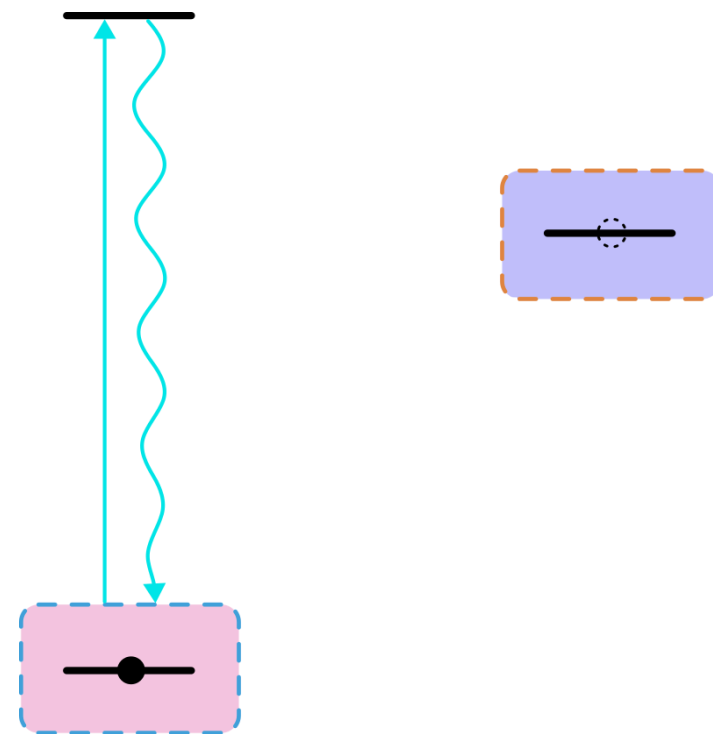
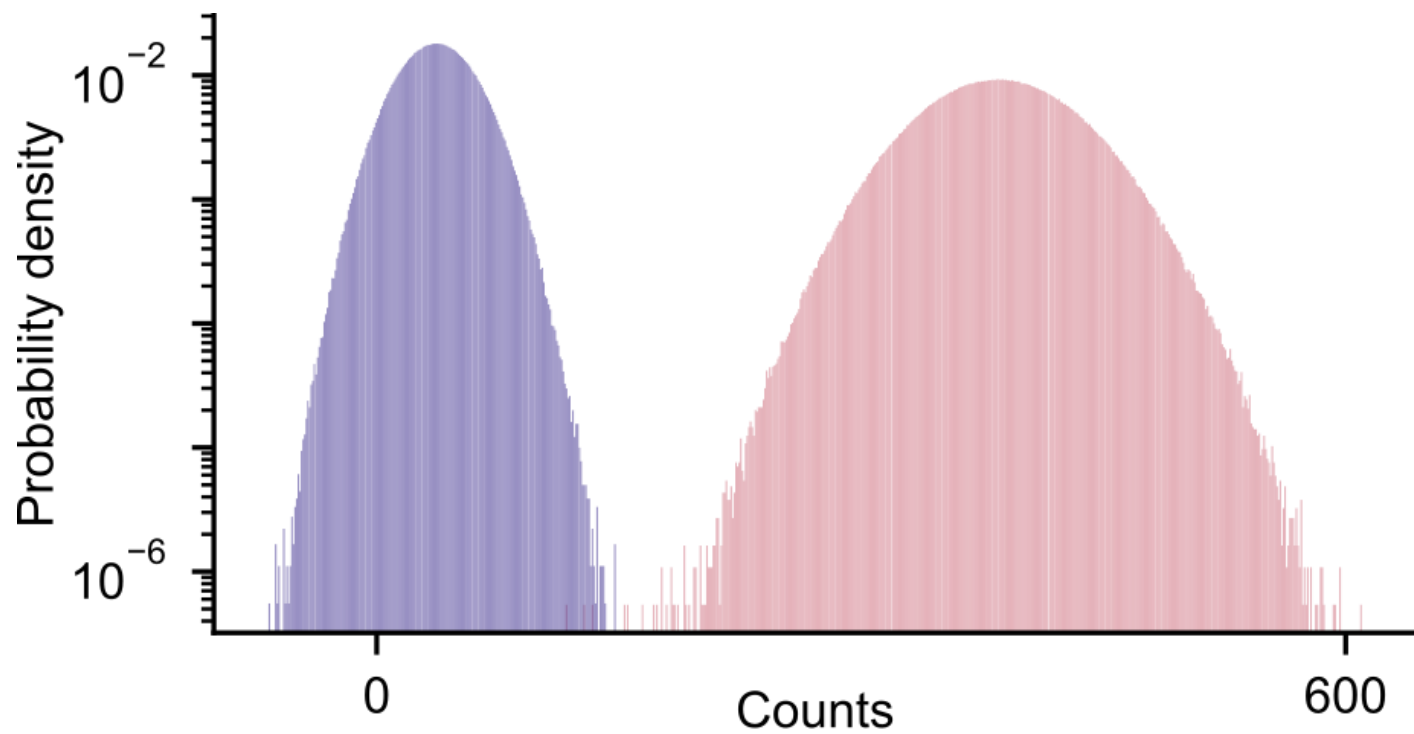

$$\varepsilon \sim 10^{-6}$$

State-prep (Metastable)

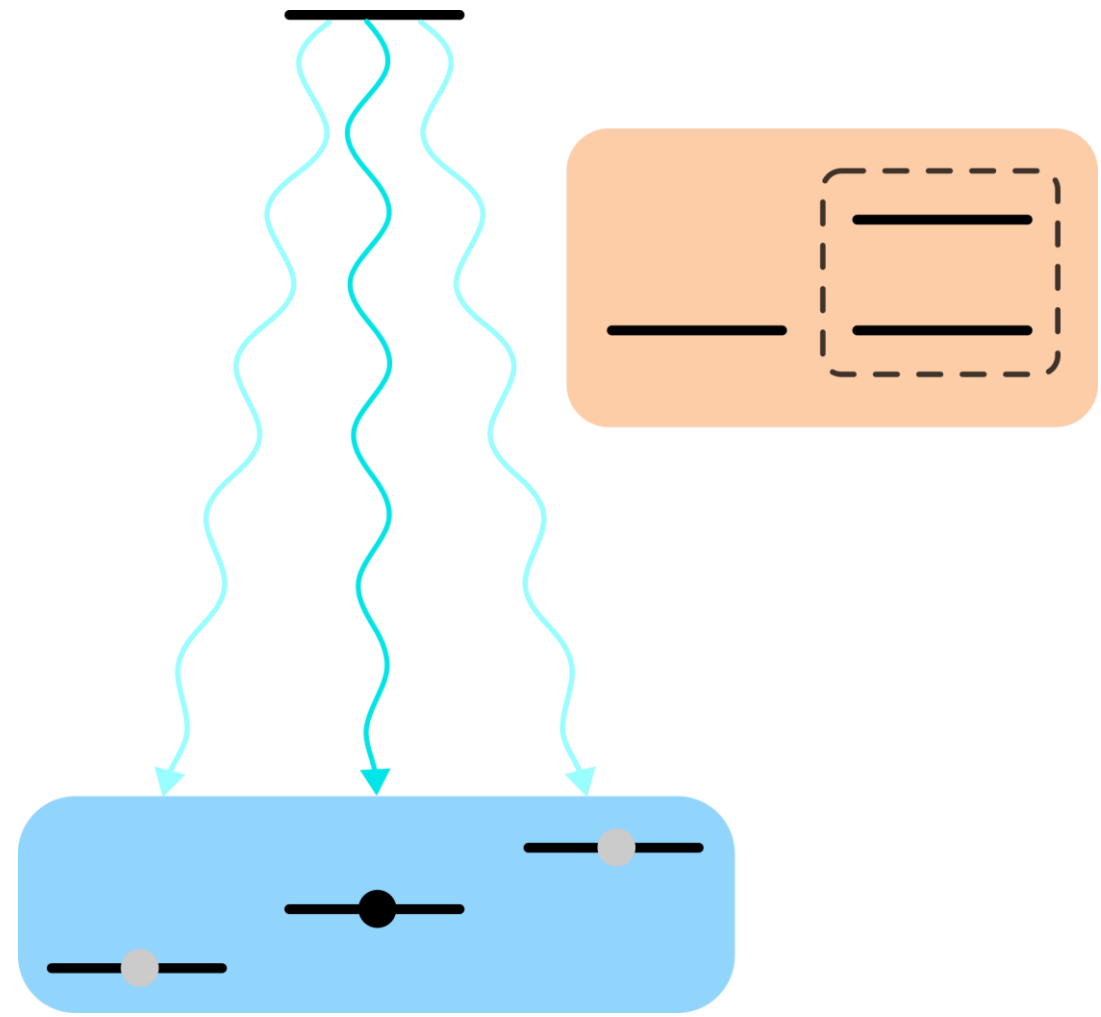

State-prep (Metastable)

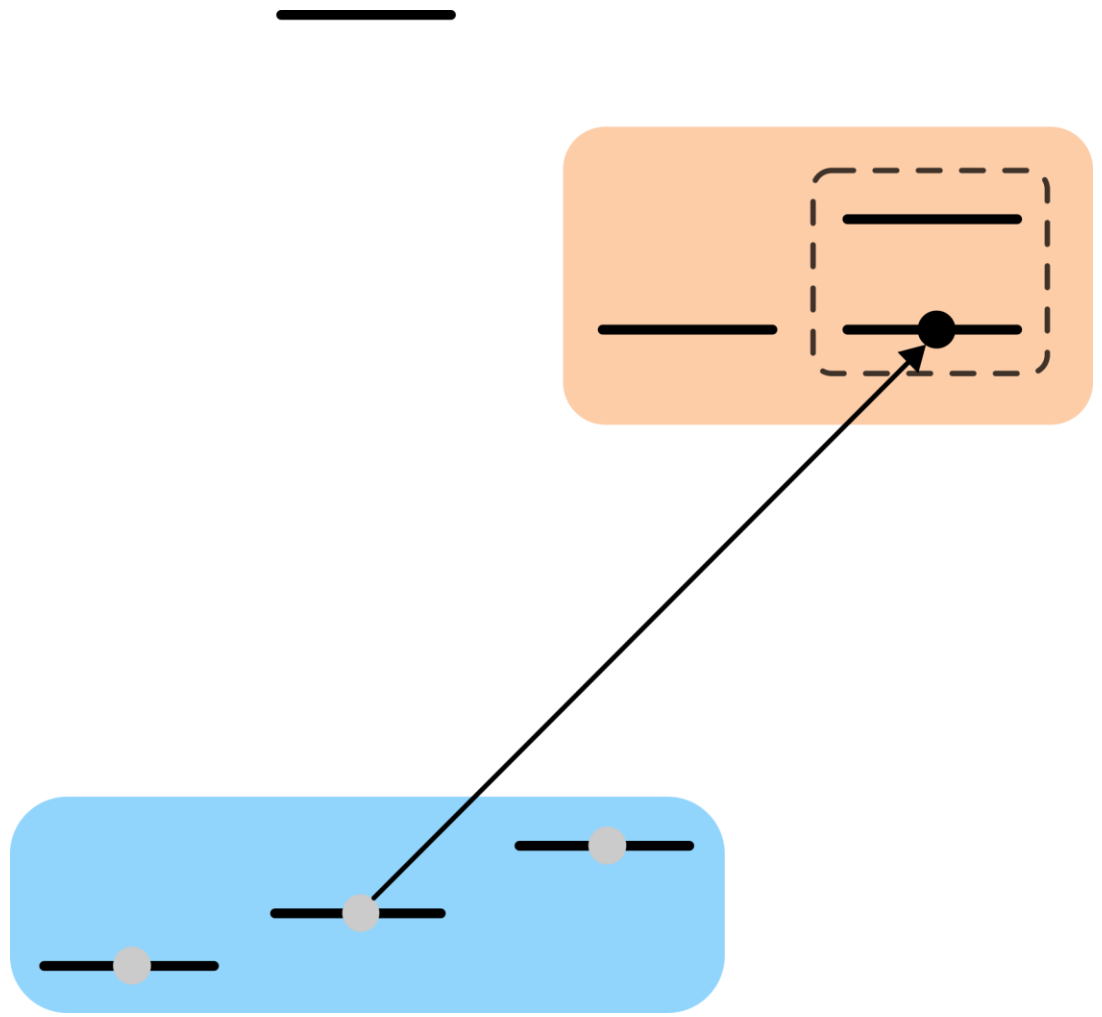

State-prep (Metastable)

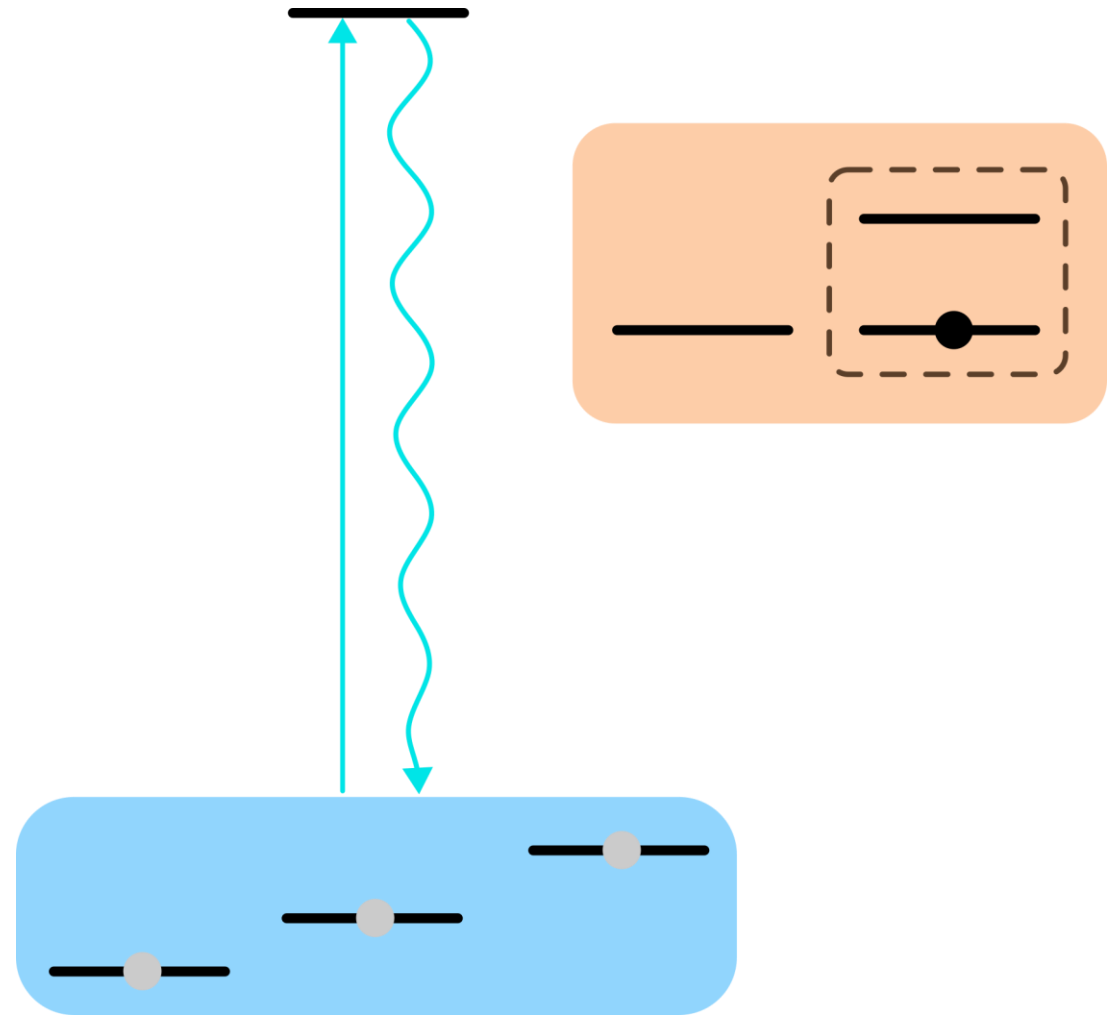
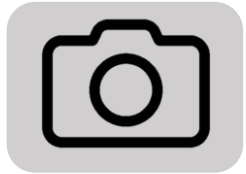

Algorithm

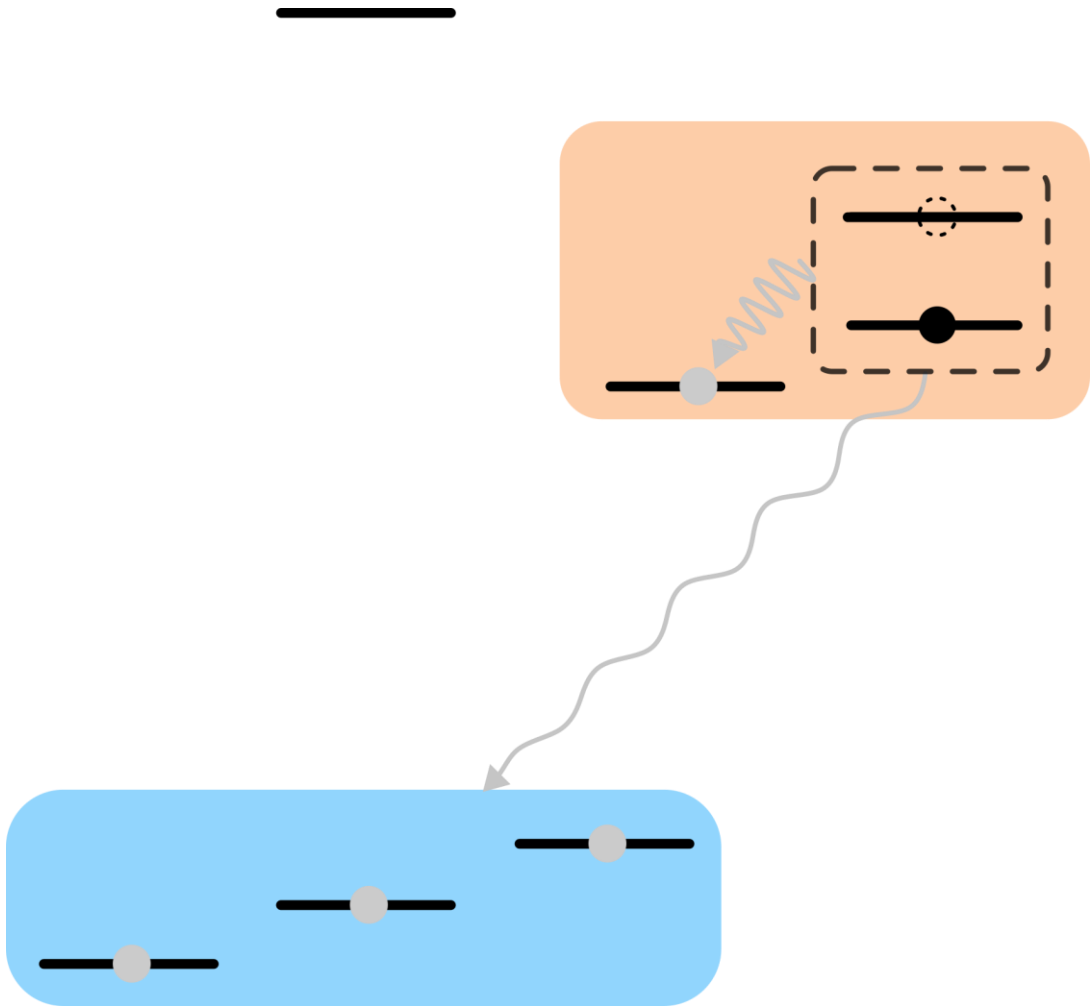
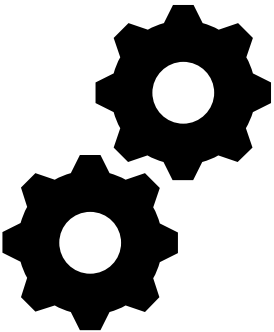

Measurement (Metastable)

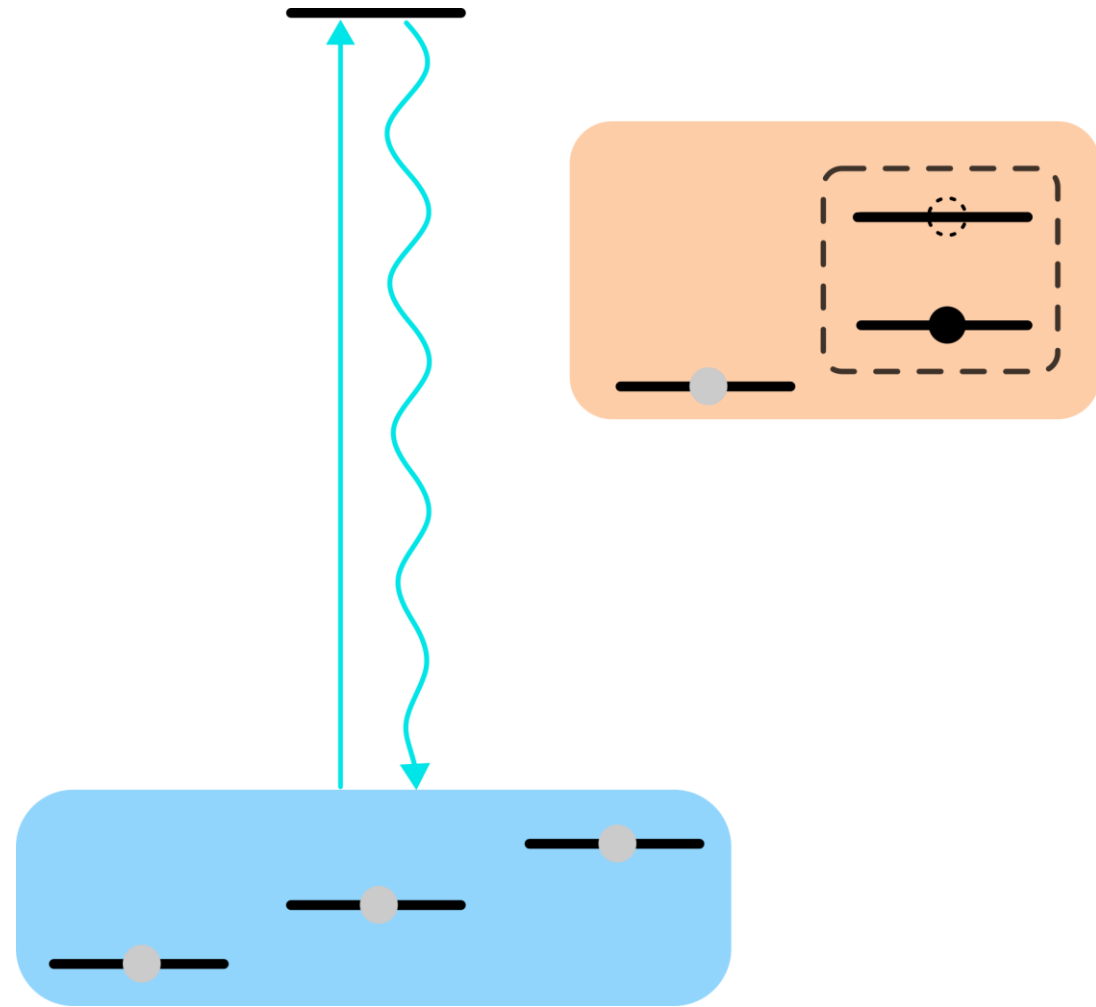
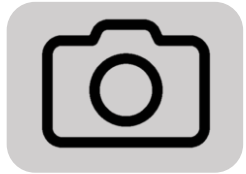

Measurement (Metastable)



$|0\rangle$



$|1\rangle$

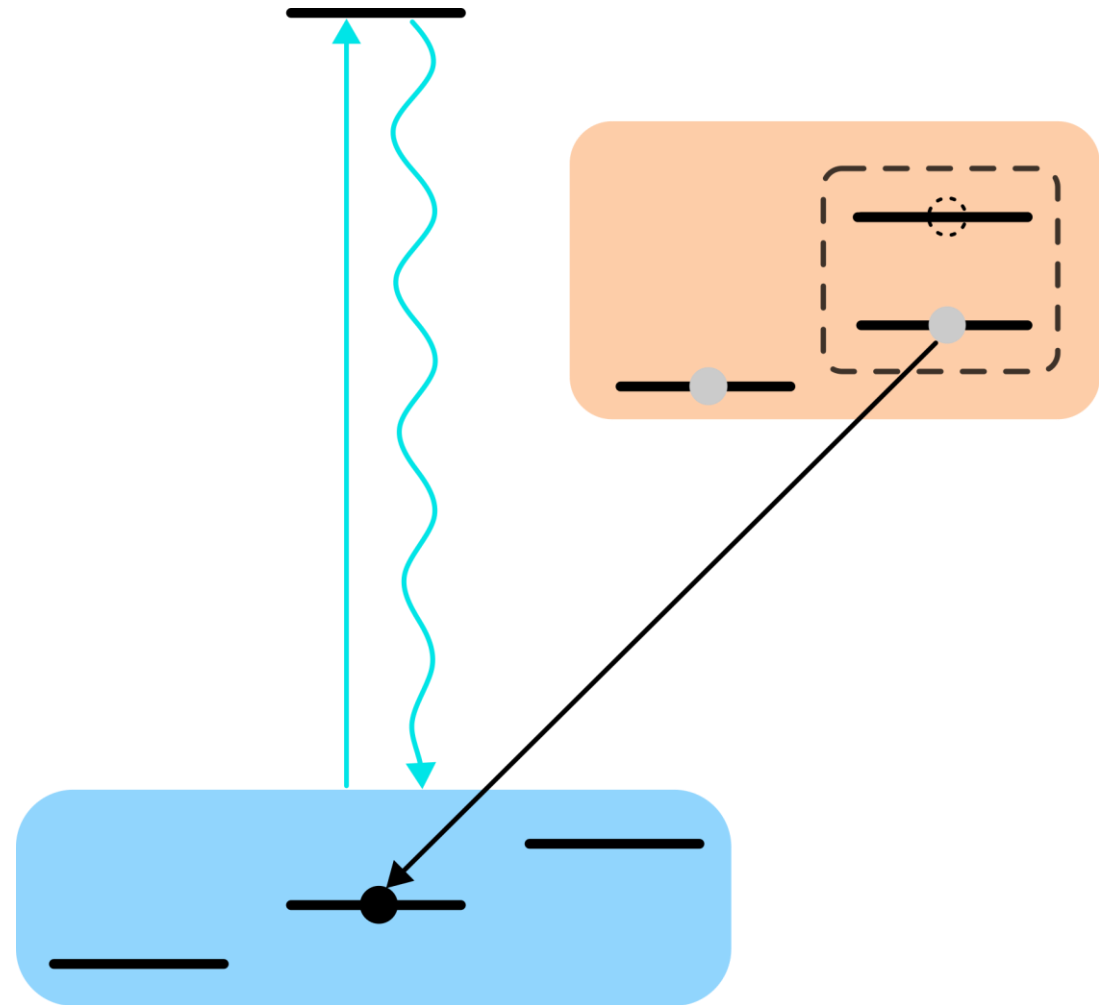

Measurement (Metastable)

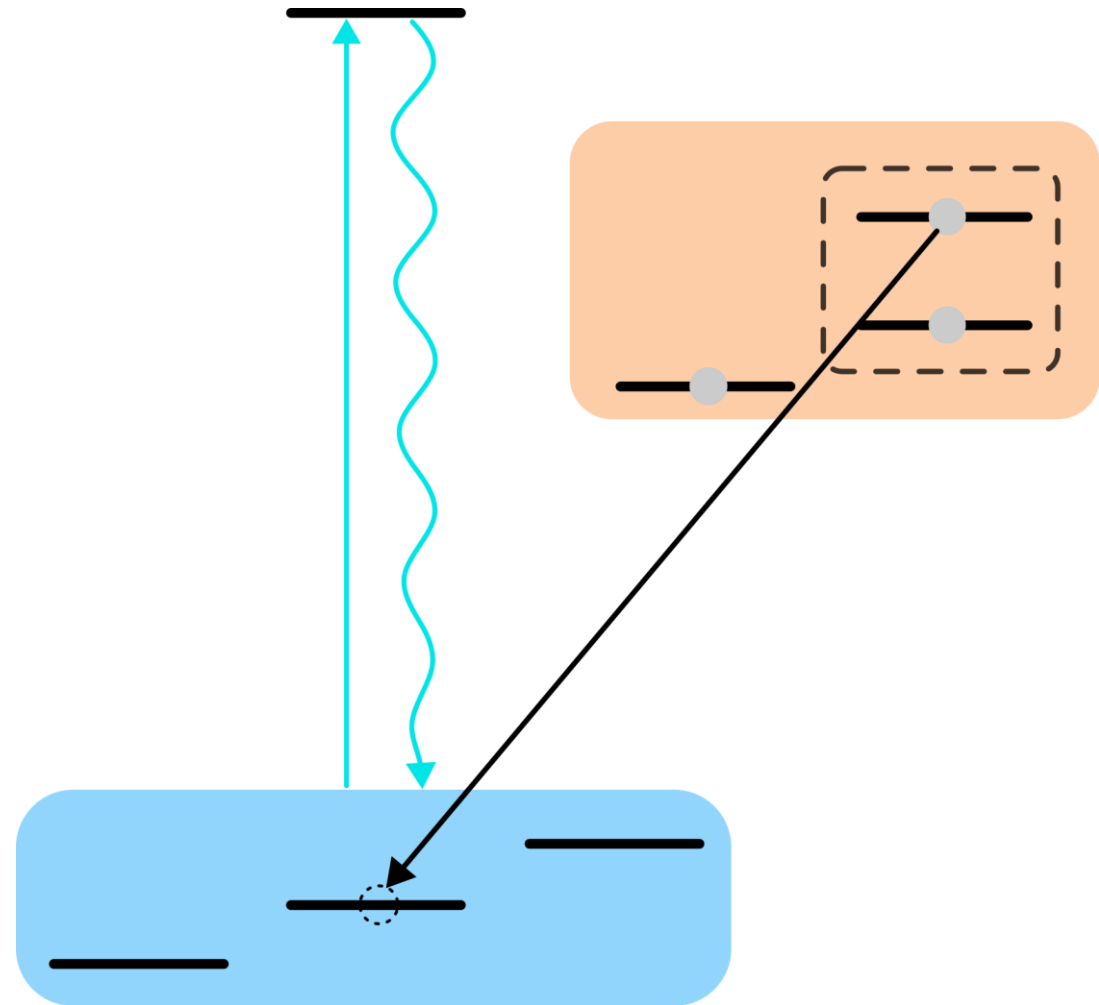
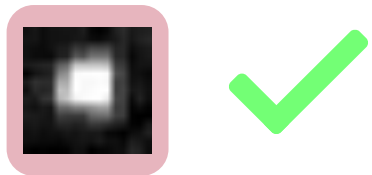
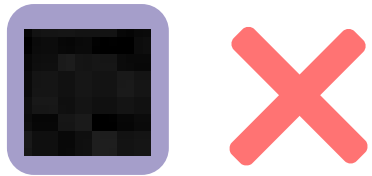
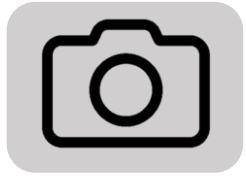

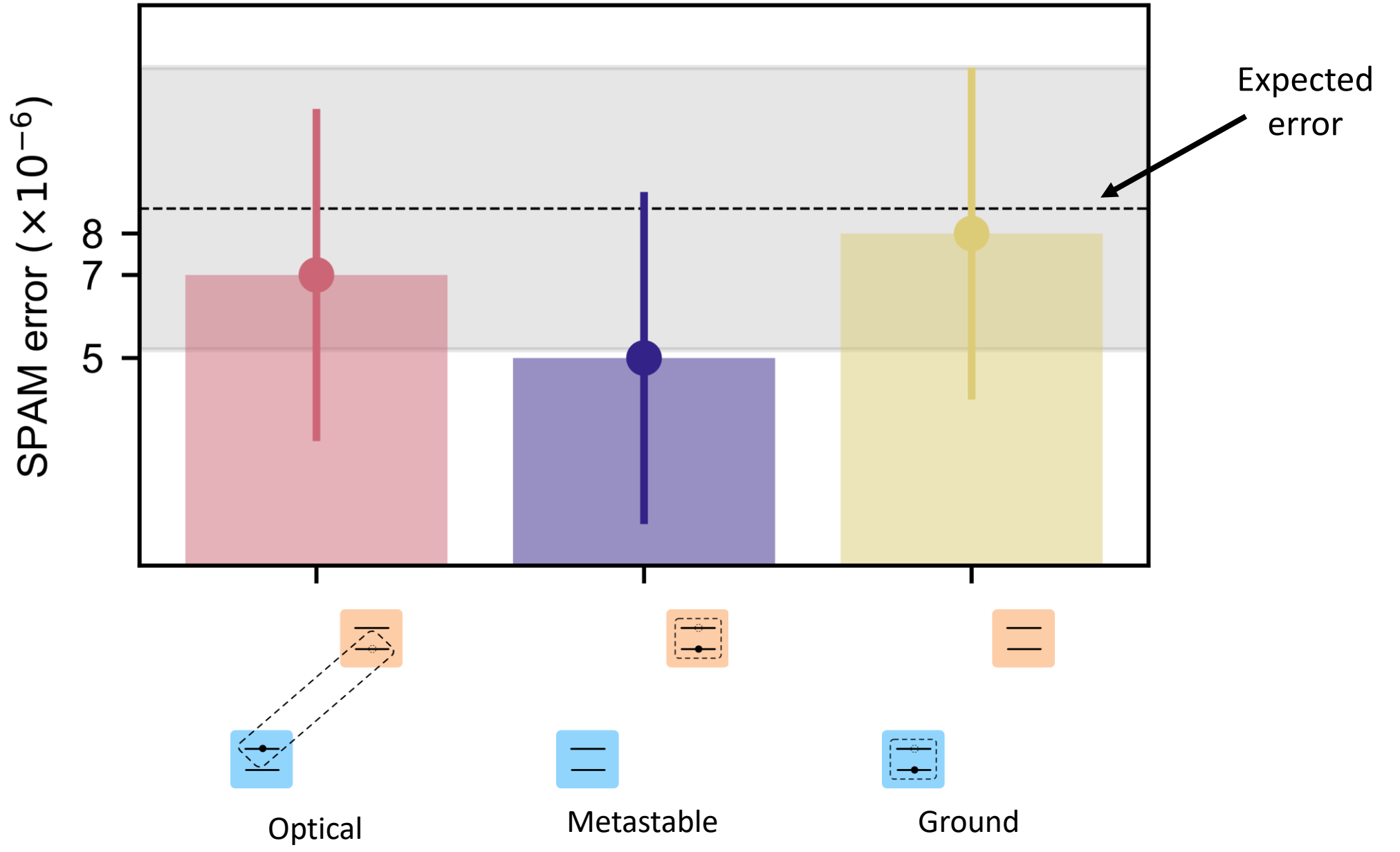

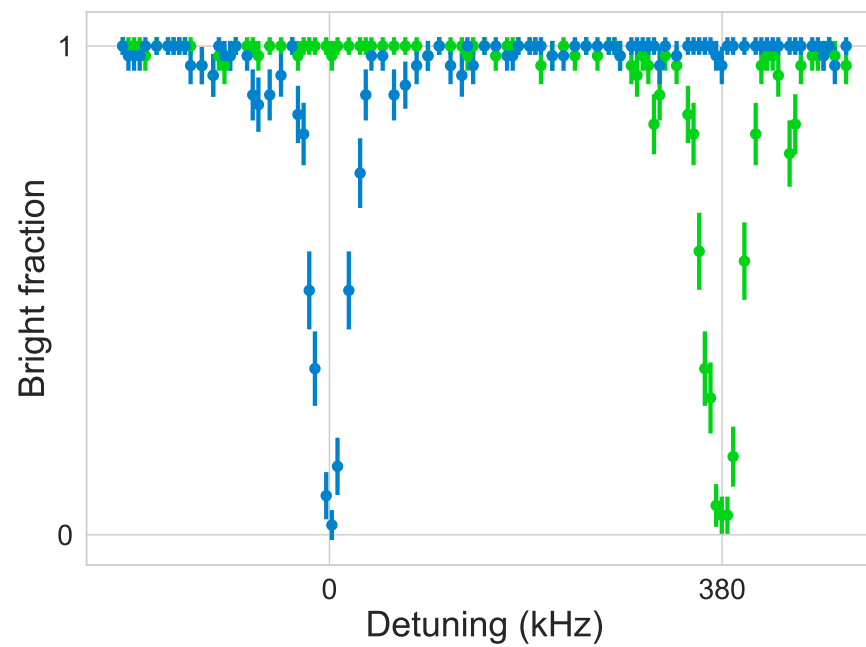
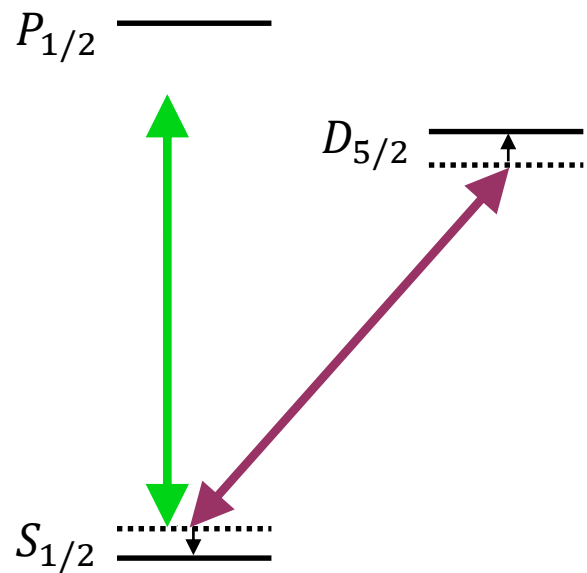
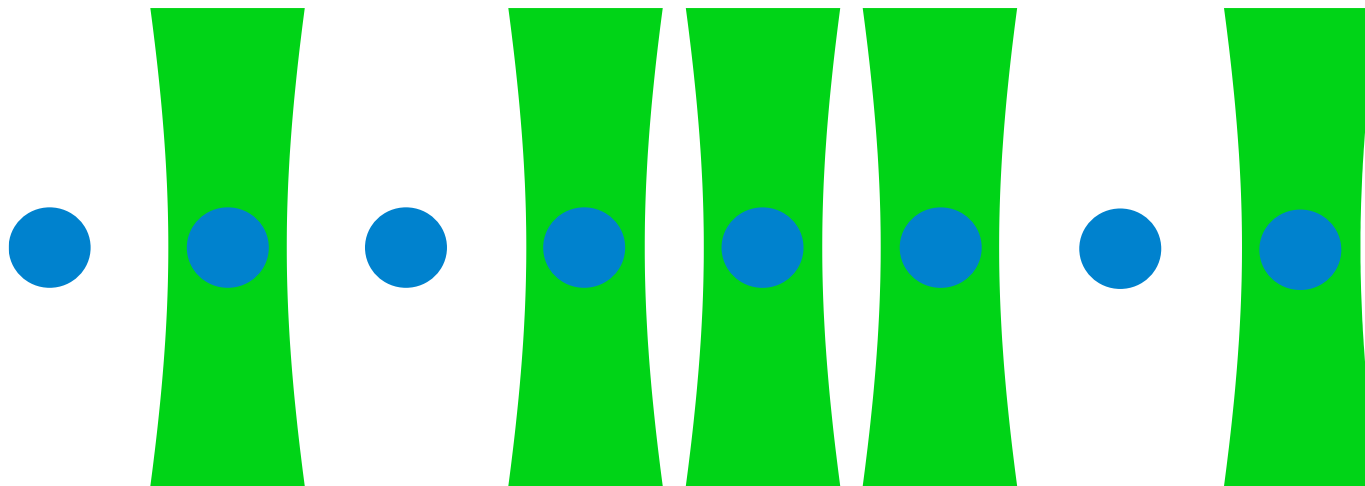

Summary

- Individual addressing of Raman lasers with low crosstalk
- Use this to perform individually addressed dissipative operations, including world-record SPAM
- Next steps:
 - Entangling gates
 - More than one qubit per ion?

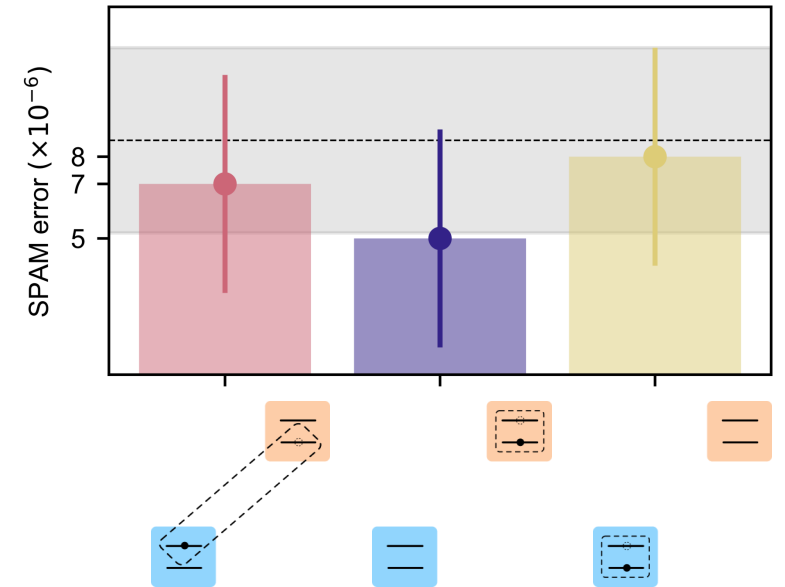
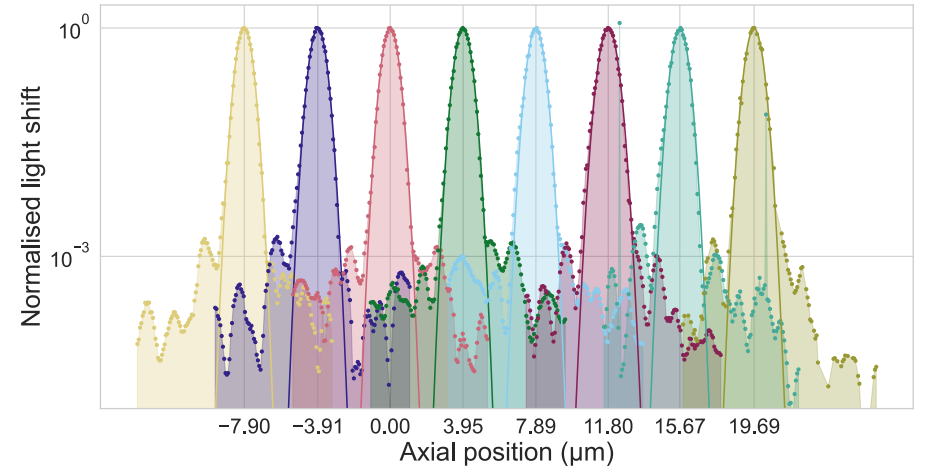

The Oxford ion trapping group

The ABaQuS project



Andres
Vazquez-Brennan
Graduate Student



Ana Sotirova
Graduate Student

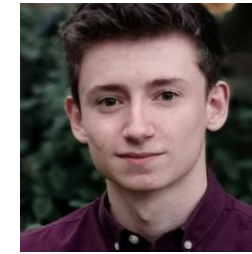

Jamie Leppard
Graduate Student



Sophie Decoppet
Graduate Student

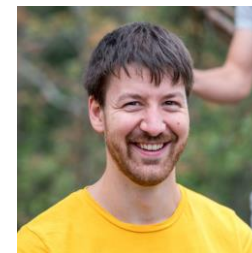

Fabian Pokorny
Postdoc



David Nadlinger
Postdoc



Chris Ballance
PI

Innovate UK



Maciej Malinowski
Oxford Ionics

