



# Flair Geometry Editor

Creating and graphically editing the FLUKA geometry

# Geometry tab – Recap

- Viewports automatically refreshed when input is changed

Layout management

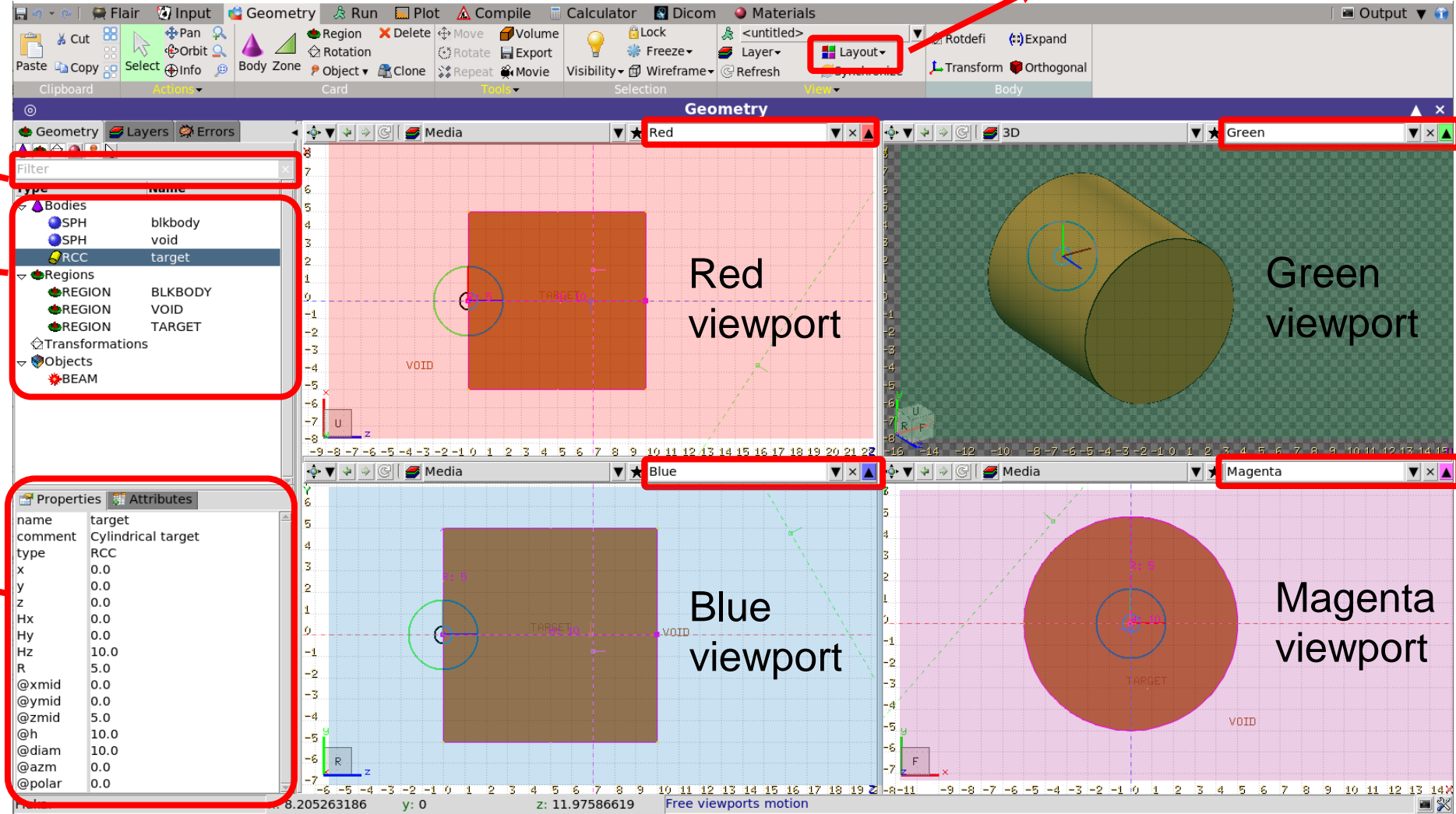

Filter

Objects Listbox

Properties & Attributes Listbox

# Layers

- Four default layers:
  - Borders
  - Media
  - 3D
  - Lattice (advanced topics)
- User can create (clone) layers  
e.g.: scoring layers
- Layers are customizable

Layer

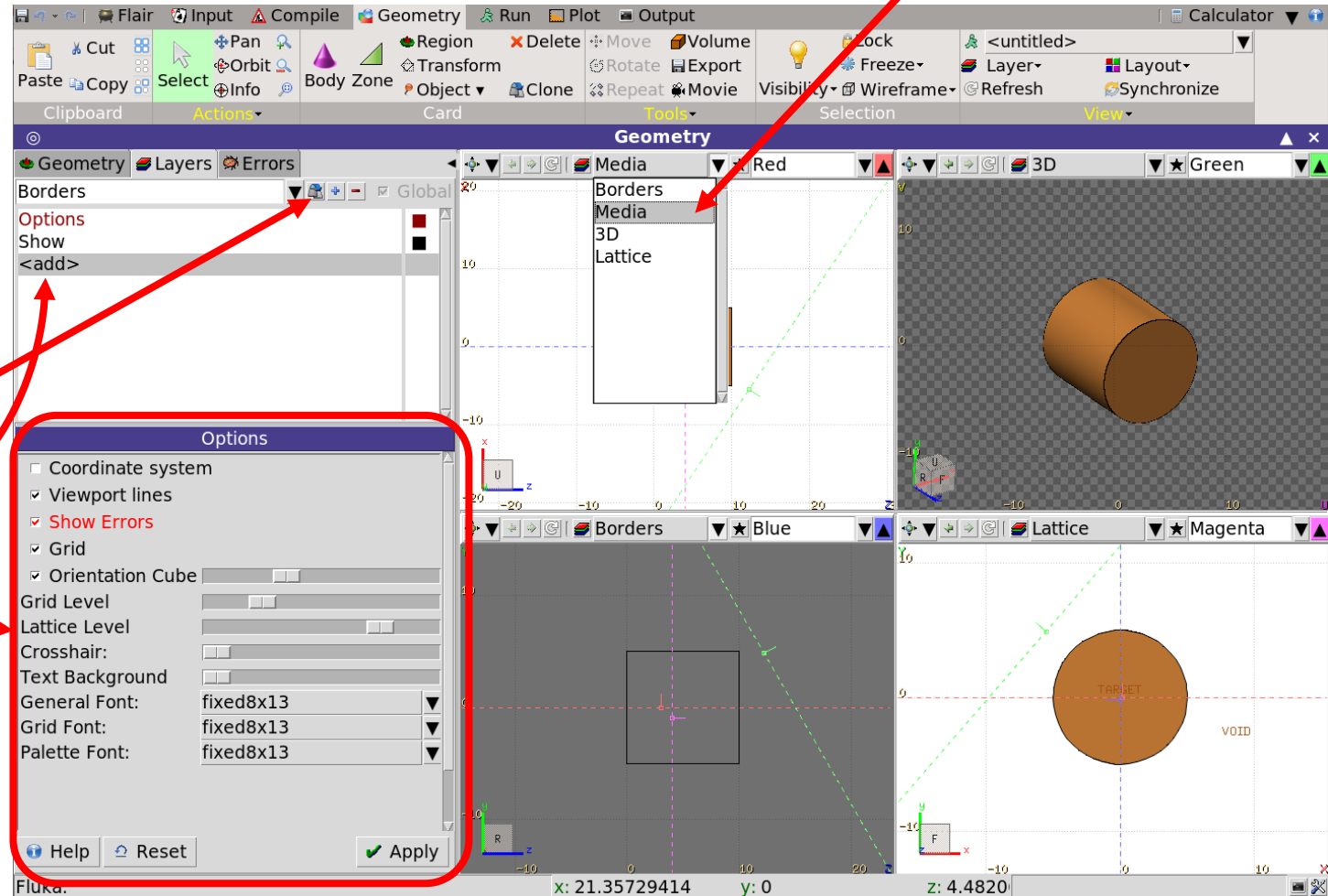

# Viewports

- Each viewport is defined by:
  - **Origin**: center of the viewport
  - **Basis**: relative axis system  $u$ ,  $v$ ,  $w$   
( $w$  is coming of the screen toward the user)
  - **Extent**: zoom
- Important note: each viewport is facing towards negative  $w$ 
  - If A and B are touching the viewport only B would be visible
  - Test it on the basic input and compare red and magenta viewports

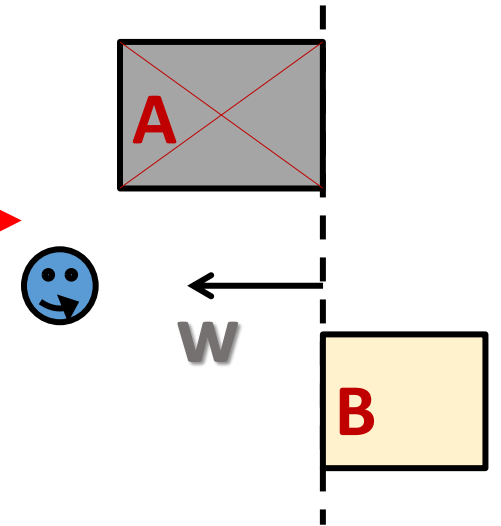
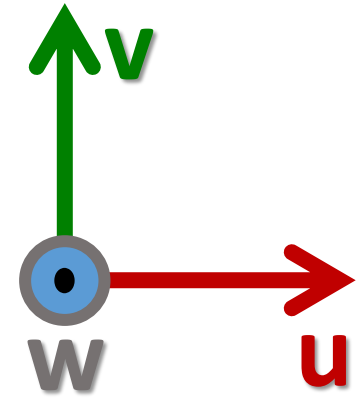

# Viewport lines – 1

- Dashed lines represent other viewports (their intersections with the current one)
- The center is indicated by a square
- The w direction is indicated by a short line
- Viewports outside the current one are displayed on the closest edge of the current viewport window

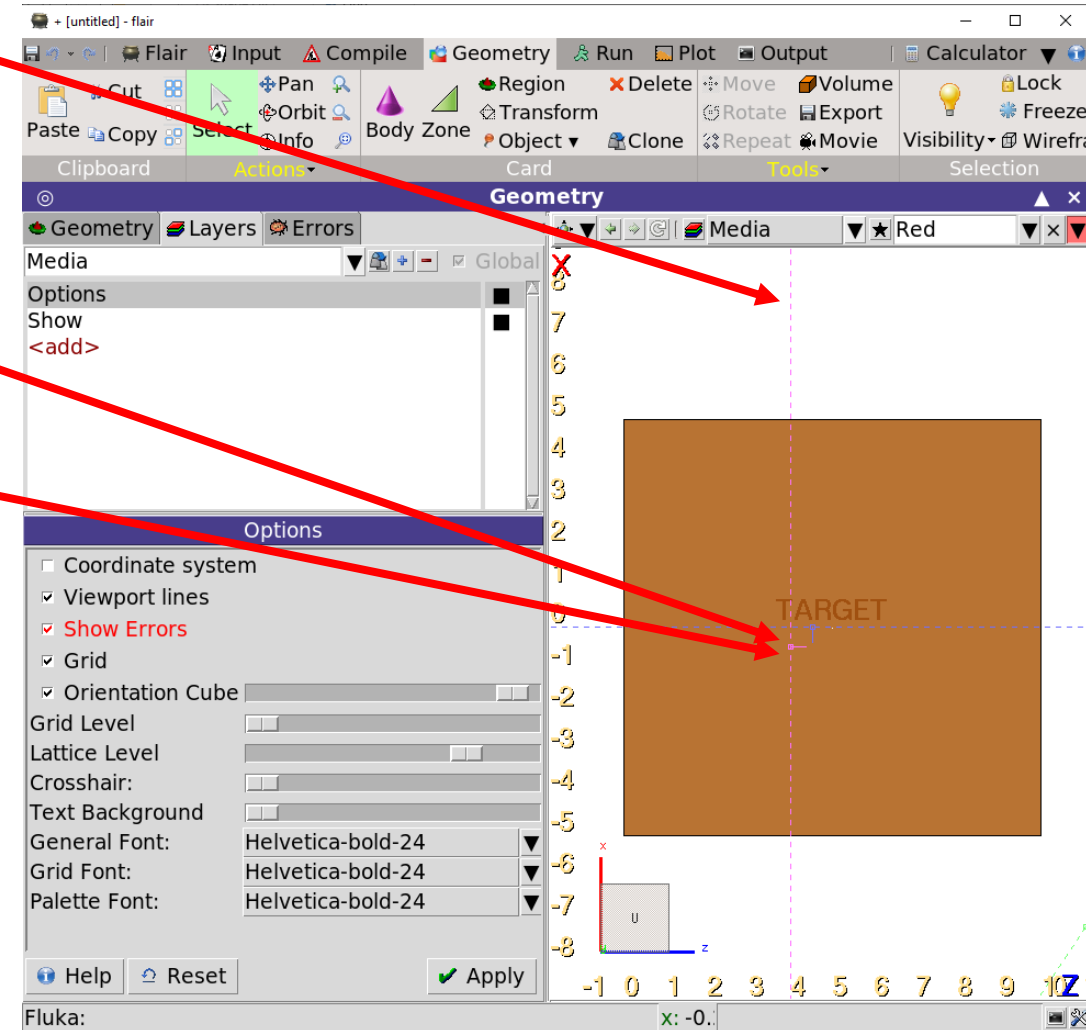

# Viewport lines – 2

- Dashed lines represent other viewports  
(their intersections with the current one)
- The center is indicated by a square
- The w direction is indicated by a short line
- Viewports outside the current one  
are displayed on the closest edge  
of the current viewport window

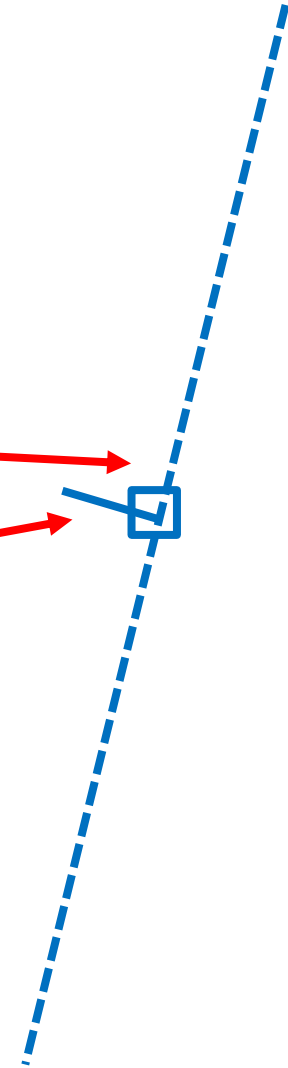

# Viewport lines actions

Select  + left mouse button:

- Drag the center square  
to reposition the viewport
- Drag the line close to the center  
to reposition the viewport along the w axis
- Drag the extremities  
to rotate it

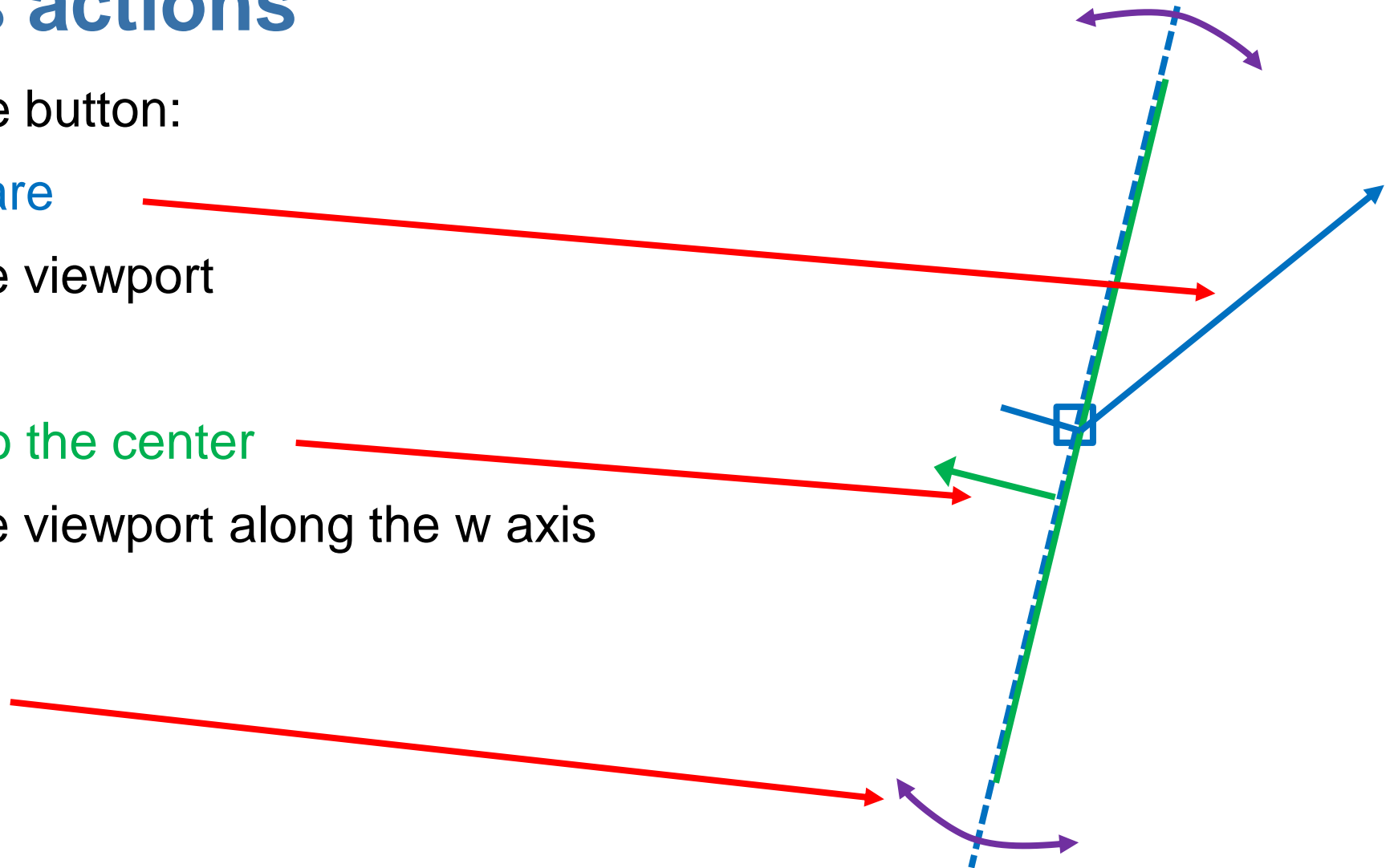

# Projection dialog

- The projection button allow to change, move, shift, rotate a viewport

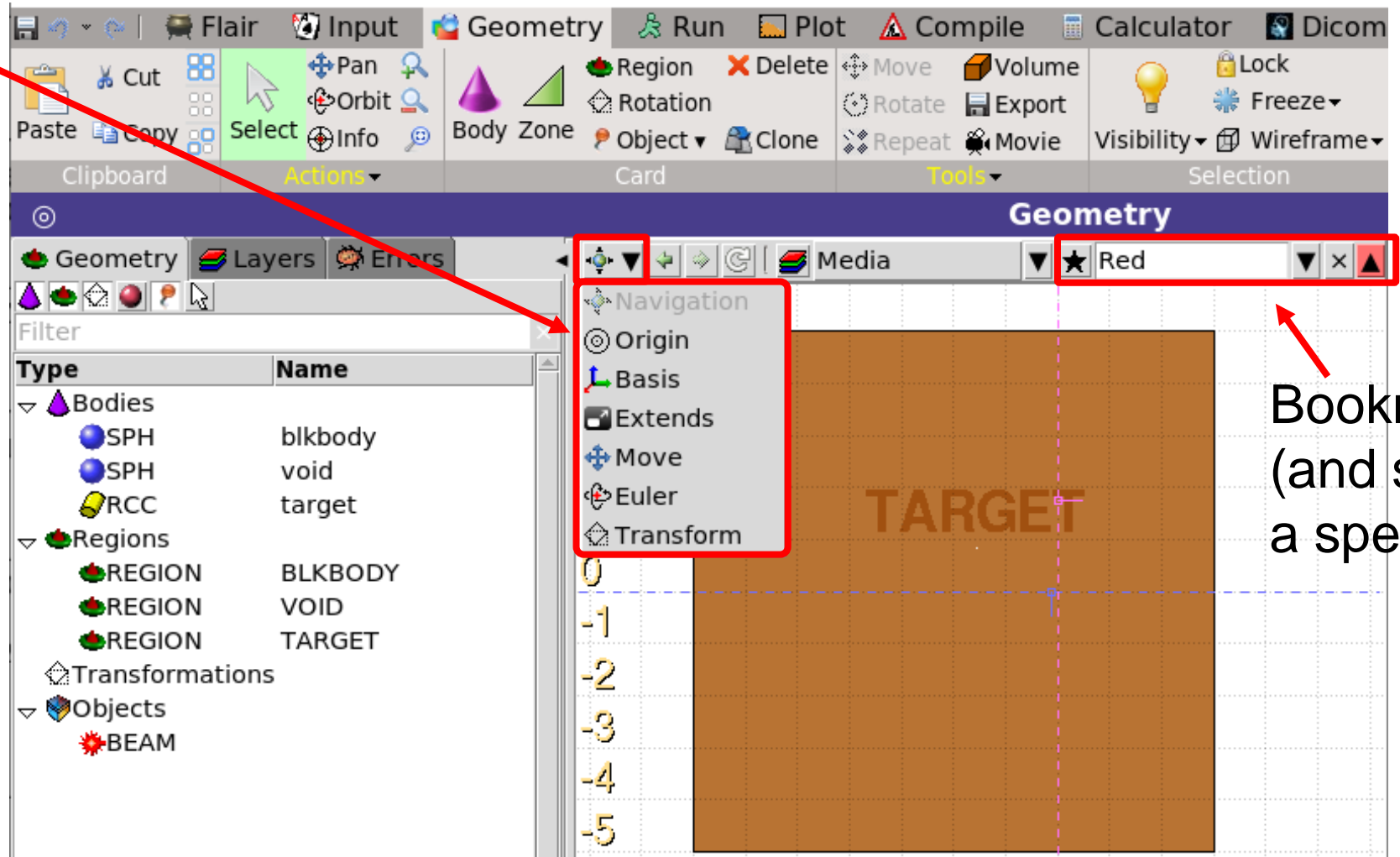

Bookmark  
(and select)  
a specific view





# Projection dialog

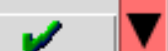

- Set the viewport's center

 ▼ x: -4.076805388 y: 0 z: 5 

- Change the reference axes

 ▼ ux: 0.0 uy: 0.0 uz: 1.0 x-y x-z -v -u   
vx: 1.0 vy: 0.0 vz: 0.0 y-z iso swap 

- Change the extent

 ▼  $\Delta u$ : 10  $\Delta v$ : 3.588143526 Aspect(X/Y): 1 



- Shift the view

 ▼ +u: +v: +w: 

- Rotate around Cartesian axes

 ▼ Rx: 90 Ry: -0 Rz: 90 

- Apply a ROT-DEFI to the viewport

 ▼ Rotdefi: testrot 





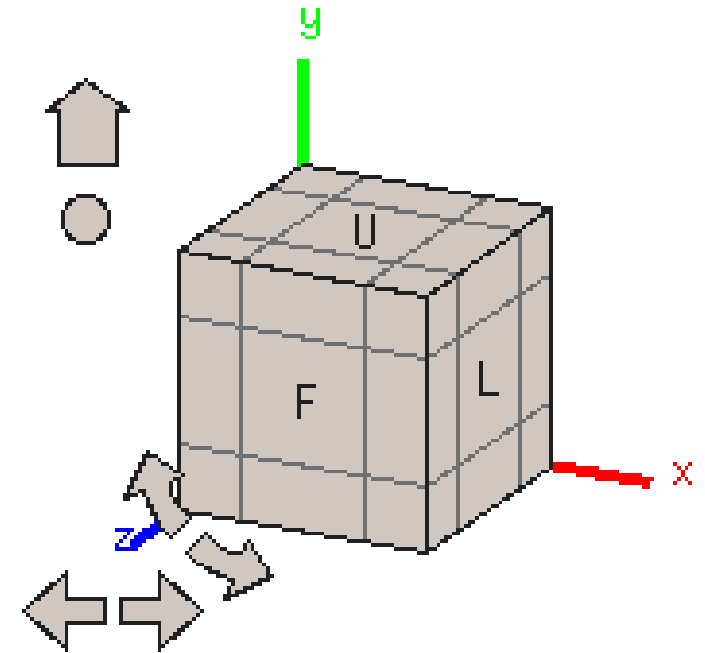

# Orientation cube

- In the bottom-left corner of each viewport
- Shows the axis system
- Allows to rotate the axes
- Similar to some CAD programs

Name	Side description
Front	X-Y plane towards the positive Z
Back	X-Y plane towards the negative Z
Up	X-Z plane towards the positive Y
Down	X-Z plane towards the negative Y
Left	Y-Z plane towards the positive X
Right	Y-Z plane towards the negative X



# Object listbox

- List type/name of bodies, regions, and objects
- Allows text filtering
- Text color-code:
  - **Red** Error in the card description
  - **Magenta** Visible body/object
  - **Orange** Selection locked
- Buttons to toggle the display of:
  -  Bodies
  -  Regions
  -  Transformations
  -  Materials
  -  Object
  -  Selected or visible items

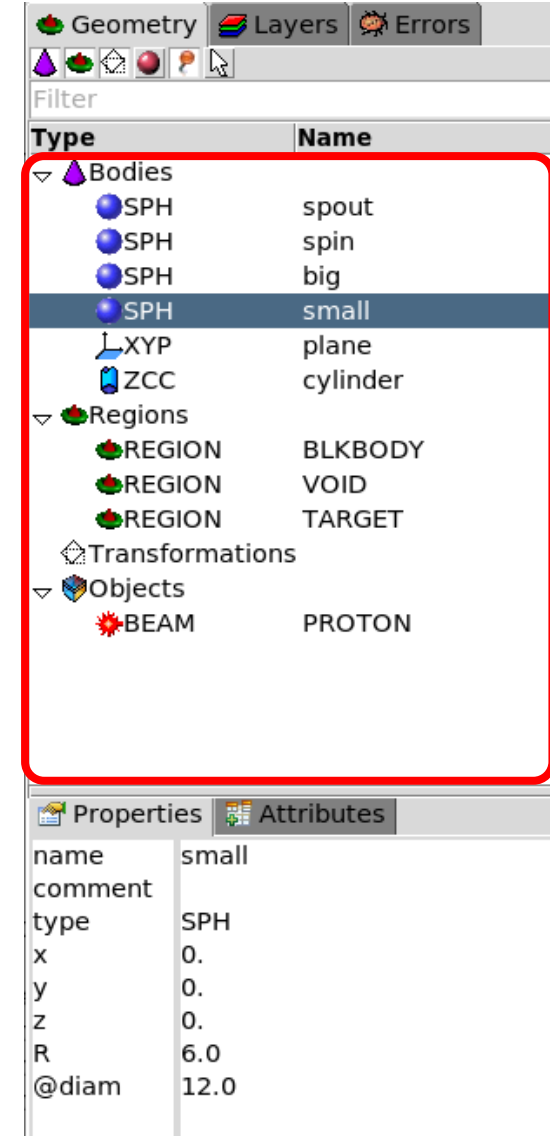

# Property and Attributes listbox

- Displays the common WHATs of the selected card
- Allows to add comments
- Allows regions editing
- Allows to assign materials (ASSIGNMA card created)
  - WARNING: it does not work if the region is within an `#if...#endif` statement
- Extra info are displayed in “Attributes”
  - Bodies: visibility, selection-locking, etc.
  - Regions: transparency, ROT-DEFI, etc.

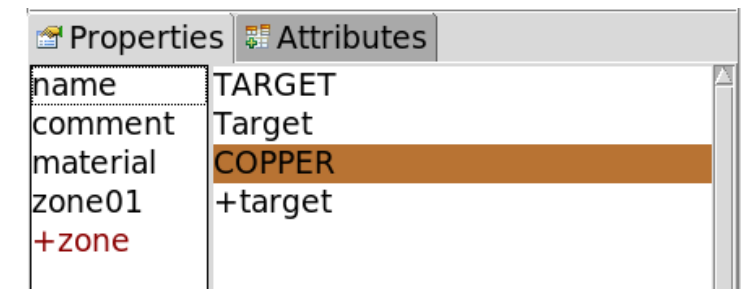
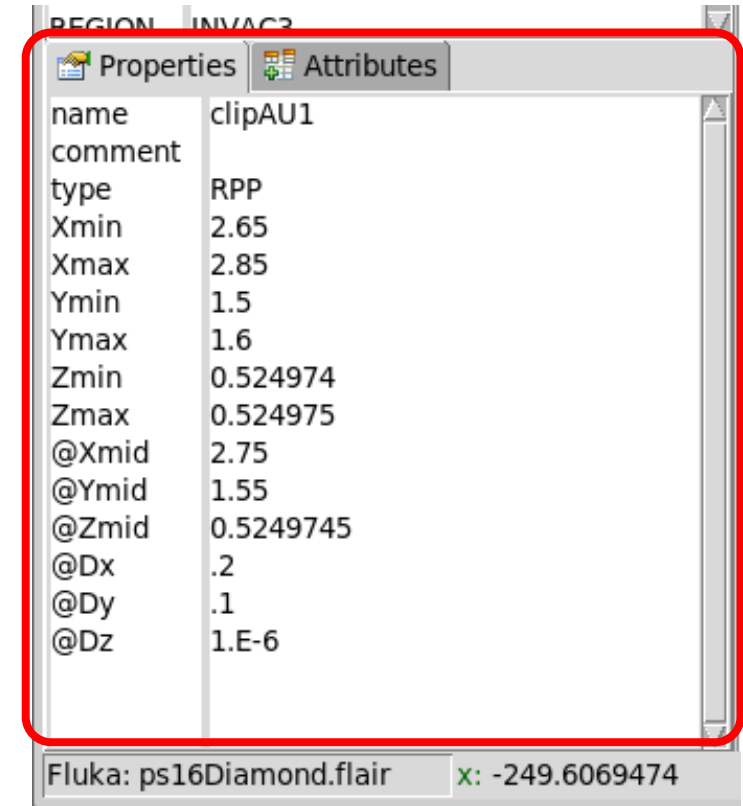

# Selection – 1

- **Objects / Bodies / Zones / Regions** can be selected using:
  - Object and/or Property listboxes
  - Graphically with the left mouse button on the viewport
- **[CTRL]**+left mouse button toggles the selection
- Area selection is also possible (click-and-drag)  
Everything inside the area is selected
- **[ESCAPE]** cancels the selection

# Selection – 2

- Selected bodies are:
  - Highlighted in **magenta** in the viewport
  - **Yellow** dots appear on their vertices
  - Highlighted in the listbox
- Selected regions are shaded
- Selected zones are shaded with hast pattern
- Zones can be selected after selecting a region
- **[ESCAPE]** cancels the selection

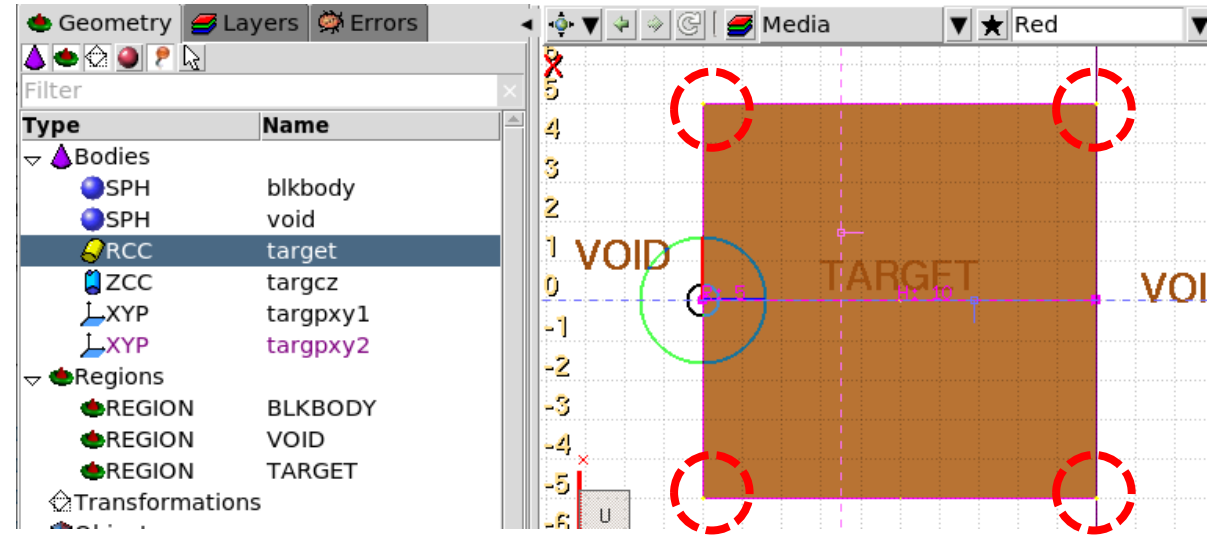

Selected region

Selected zone

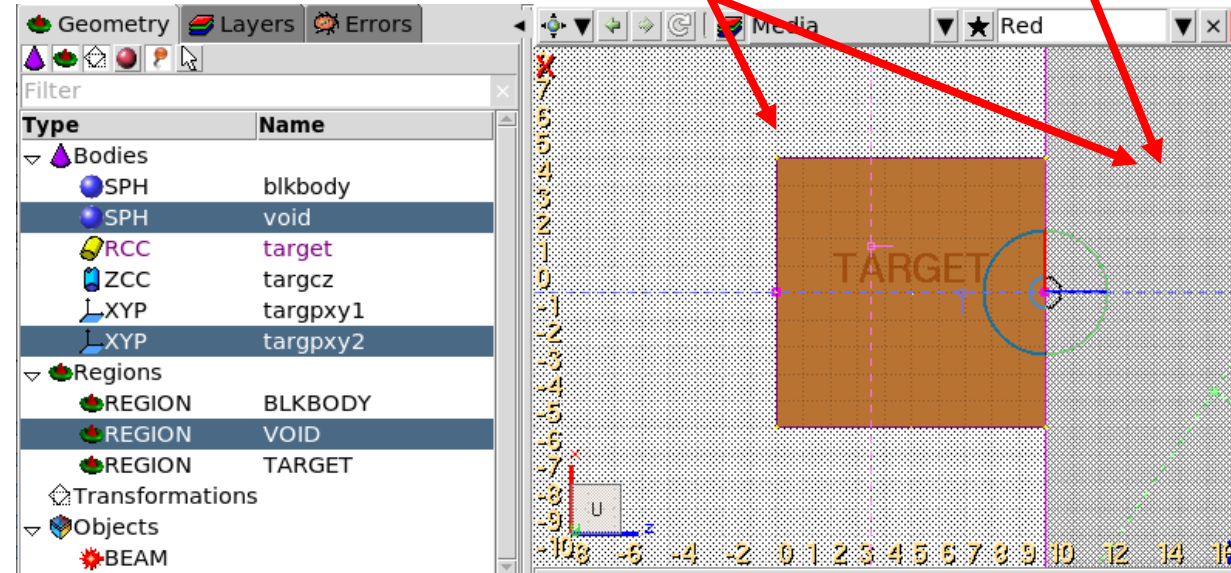

# Adding a new body

- Right-click or [b] or [Space] or [INS]
- Menus are organized in sub-categories
- Capital [B] to repeat last add-body
- Left-click on the desired location of the new body
- Extended bodies require to left-click each characteristic
- New bodies are named after the last body renamed
  - e.g. john → john1 → john2 → john3 → etc.
- [n] allows to fast edit object name
- IMPORTANT: Renaming a body will automatically rename any reference to it, without asking the user  
e.g. a body used in a region definition

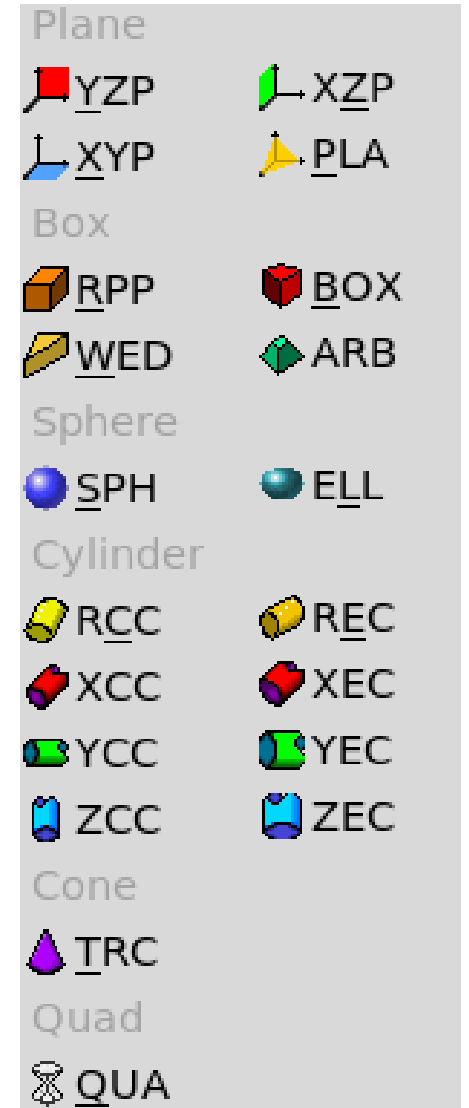

# Body visibility – 1

- Default: body segments are only visible when they represent borders of REGIONS
- Bodies become visible when selected

ZCC targcz

Not selected → Not visible

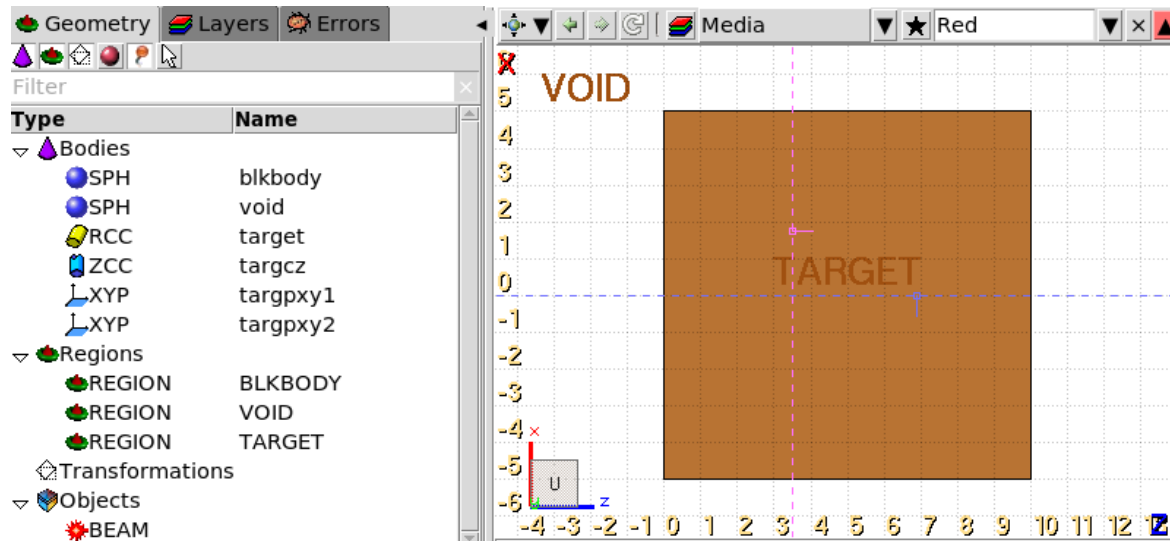

ZCC targcz

Selected → Visible

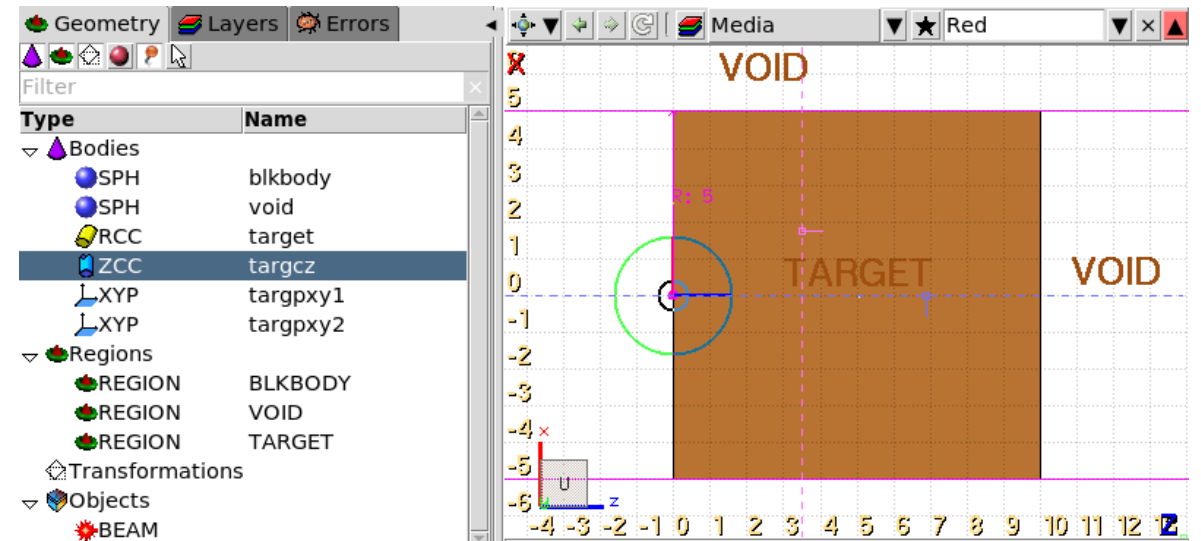



# Body visibility – 2

- Visibility default can be changed in the “Attributes” of each body

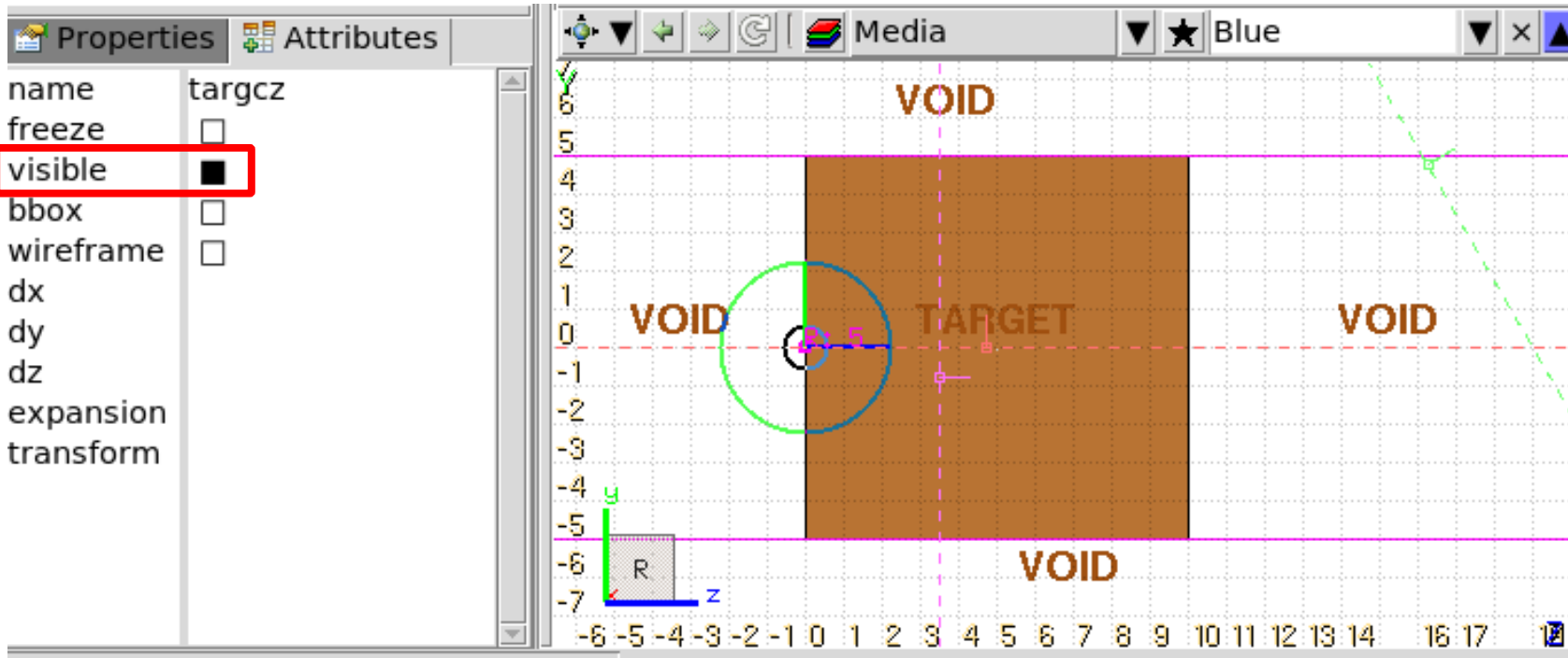

ZCC targcz  
Not selected but visible!

- Shortcut [v] or Toolbar button

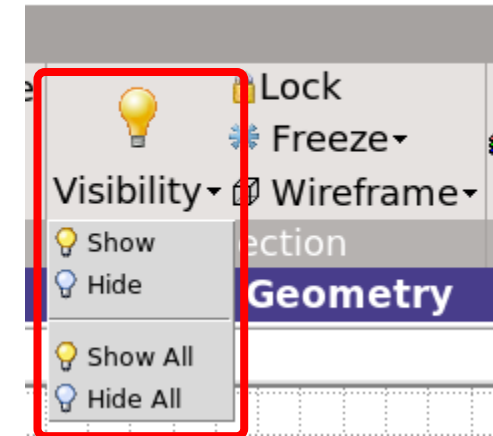

# Body editing – 1

- Bodies can be edited typing their coordinates/values
  - in the [Properties](#) or
  - in the Flair input editor
- Graphically
  - Selecting a body the action handle is displayed
  - Left-click the small circle to freely move (shortcut: [g]-grab)
  - Left-click the big circle to rotate around the w axis (shortcut: [r]-rotate)
  - Left-click the [red/green/blue](#) lines to move along the X, Y, or Z axis
  - While moving a body, hit [x], [y], or [z] to lock movement along the selected axis

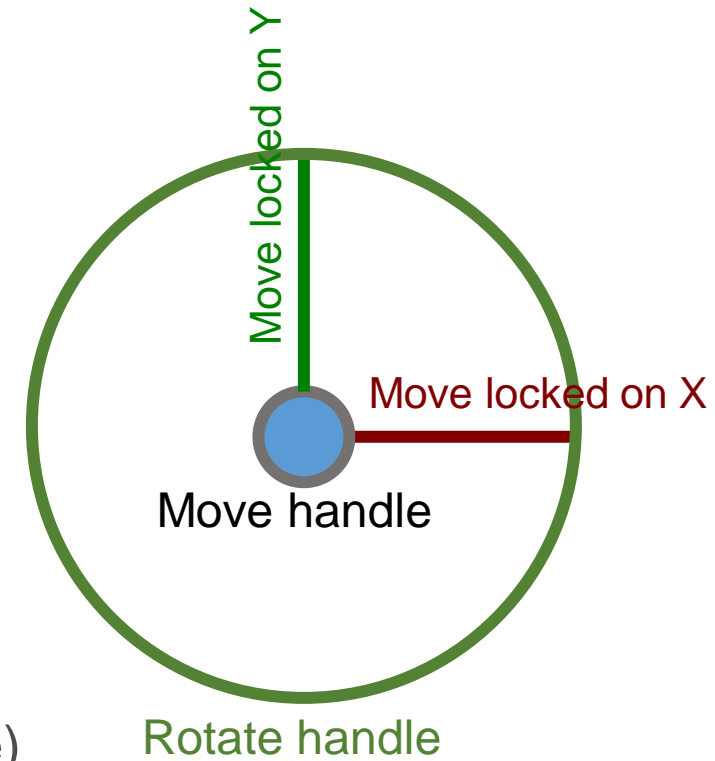

# Body editing – 2

- When a body is selected and the handles are shown, it's possible to click-and-drag the handler to move, rotate, and resize the object
- TRC example
  1. On the base plane, to move it normally to the height vector
  2. On the small square on the apex plane, to move the height vector
  3. On the apex plane, to move it normally to the height vector
  4. On the conic surface close to the apex, to resize the apex radius
  5. On the conic surface close to the base, to resize the base radius

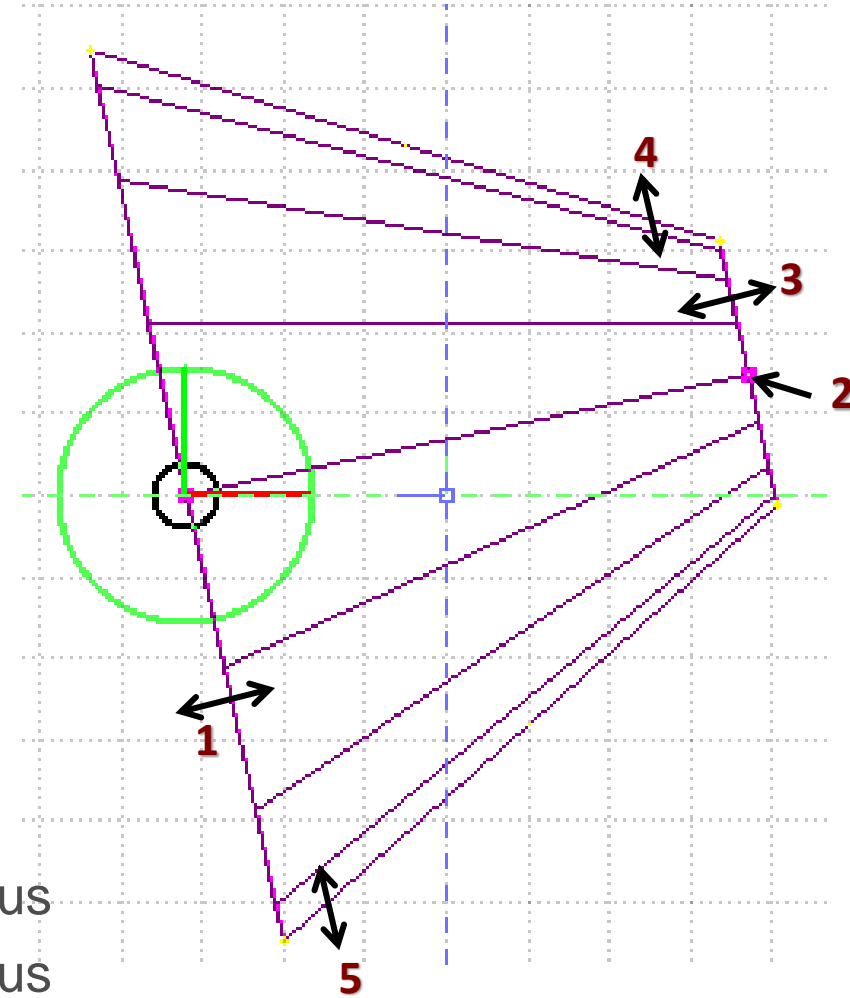

# Adding a new region

- Right-click or [R] or [Space] or [INS]
- Immediately, the property listbox is activated to edit the name
- Assigning a material to a region, automatically generated the ASSIGNMA card
- However, deleting a region does not remove the corresponding ASSIGNMA card
- **IMPORTANT:** Renaming a region will automatically rename  
any reference to it, without asking the user  
e.g. in the **ASSIGNMA** card

# Zone editing

## IMPORTANT REMINDER:

- A zone is a subregion expressed in terms of “+” and “-” only, e.g.

REGION “+a +b | +c -d”

contains 2 zones

zone1: +a +b

zone2: +c -d

# Zone editing – with the keyboard

- Add a zone: enter the expression in the “+zone” field
- Modify a zone: select the zone to modify and edit its expression
- Delete a zone: select the zone to delete either:
  1. Right-click → Delete or
  2. Hit [Del] while the pointer is inside the Property Listbox

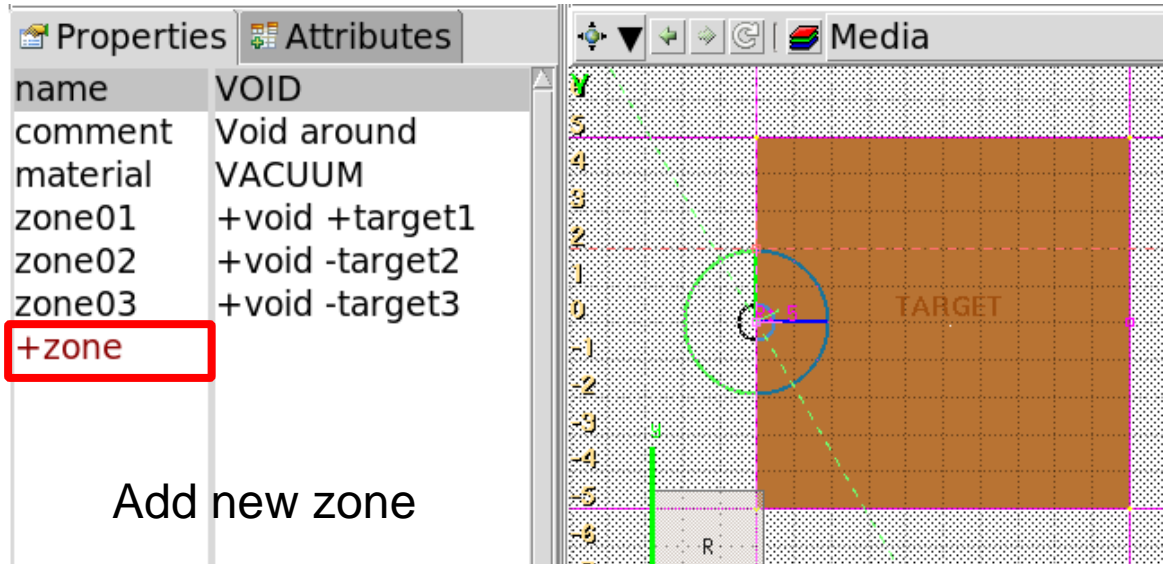

# Zone editing – graphically

- First, select the REGION to which the zone to add/modify belongs
- Add a new zone
  - Verify that no zone is selected in the property listbox (unselect using [ESC])
  - Add on the selection ONLY the bodies representing the zone borders

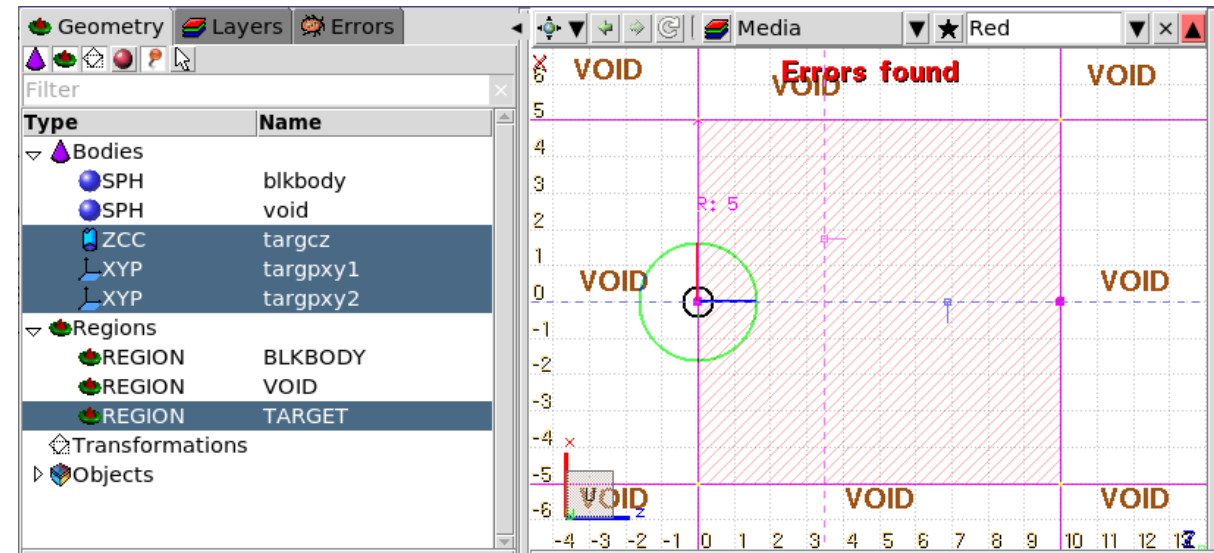
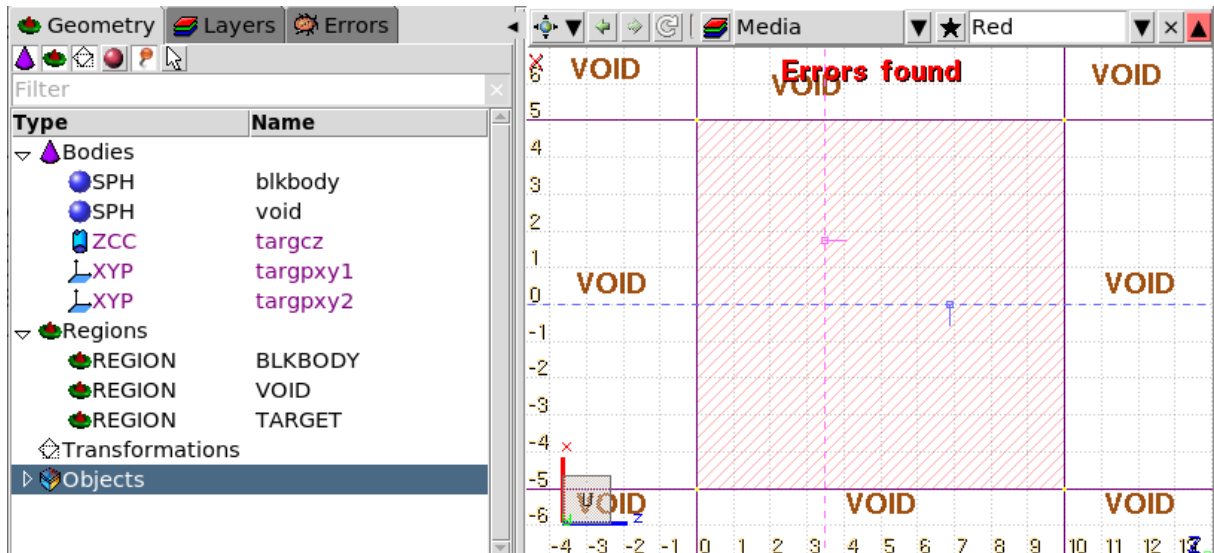

# Zone editing – graphically

- First, select the REGION to which the zone to add/modify belongs
- Add a new zone
  - Verify that no zone is selected in the property listbox (unselect using [ESC])
  - Add on the selection ONLY the bodies representing the zone borders
  - Right-click or [Space] to open a pull-down menu
  - Select Zone  (shortcut [d])

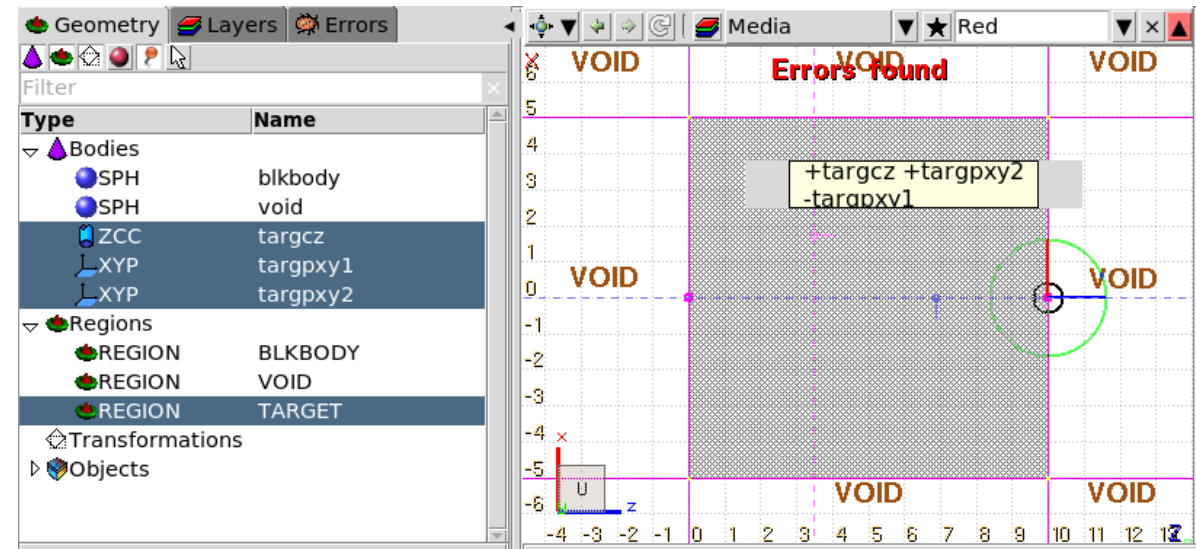
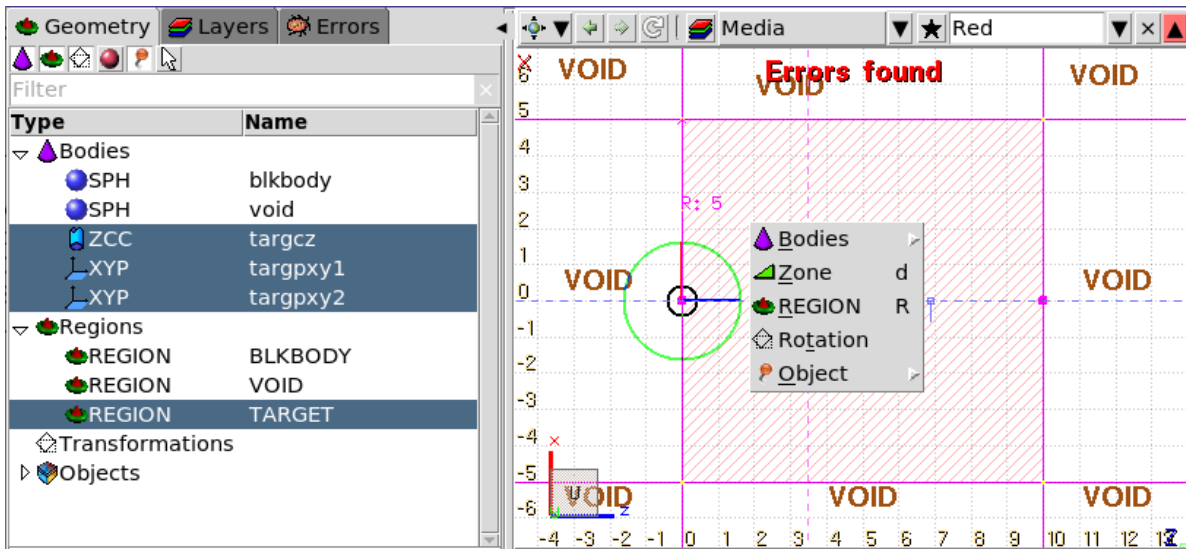



# Zone editing – graphically

- First, select the REGION to which the zone to add/modify belongs
- Add a new zone
  - Verify that no zone is selected in the property listbox (unselect using [ESC])
  - Add on the selection ONLY the bodies representing the zone borders
  - Right-click or [Space] to open a pull-down menu
  - Select Zone  (shortcut [d])
  - Left-click over a point in any viewport that should belong to the new zone
  - The zone is automatically created

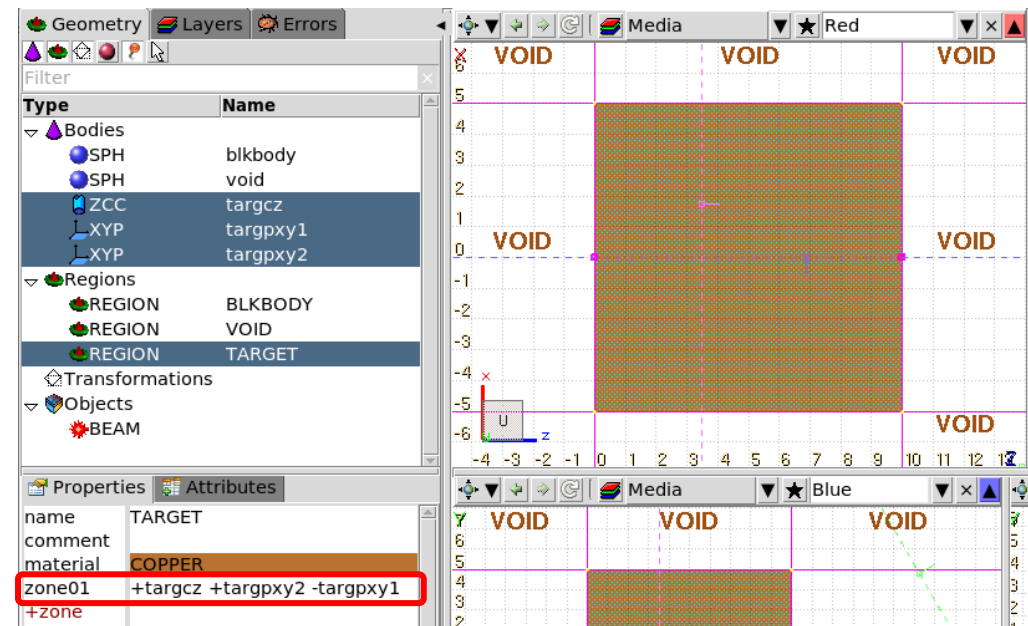

# Zone editing – graphically

- First, select the REGION to which the zone to add/modify belongs
- Edit an existing zone
  - Select a zone either graphically or on the property listbox
  - All bodies involved in the zone definition are automatically selected
  - While the zone is selected, (un-)select bodies (not) needed for the zone definition
  - Then proceed as for adding a new zone
  - Right-click or [**Space**] to open a pull-down menu
  - Select Zone  (shortcut [**d**])
  - In any of the viewports, left-click on a point that should belong to the zone
  - The zone is automatically updated
- **IMPORTANT:** select only needed bodies (extra bodies slow down simulations)

# Zone editing – Example [1/9]

- How to create a sphere with a cylindrical hole cut with a tilted plane (@30°)

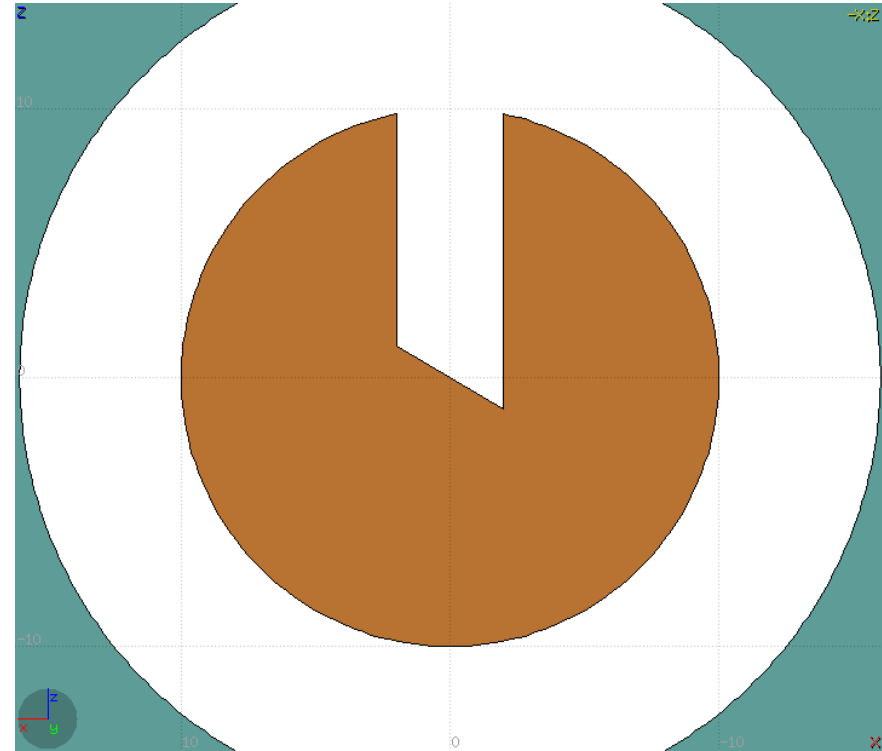
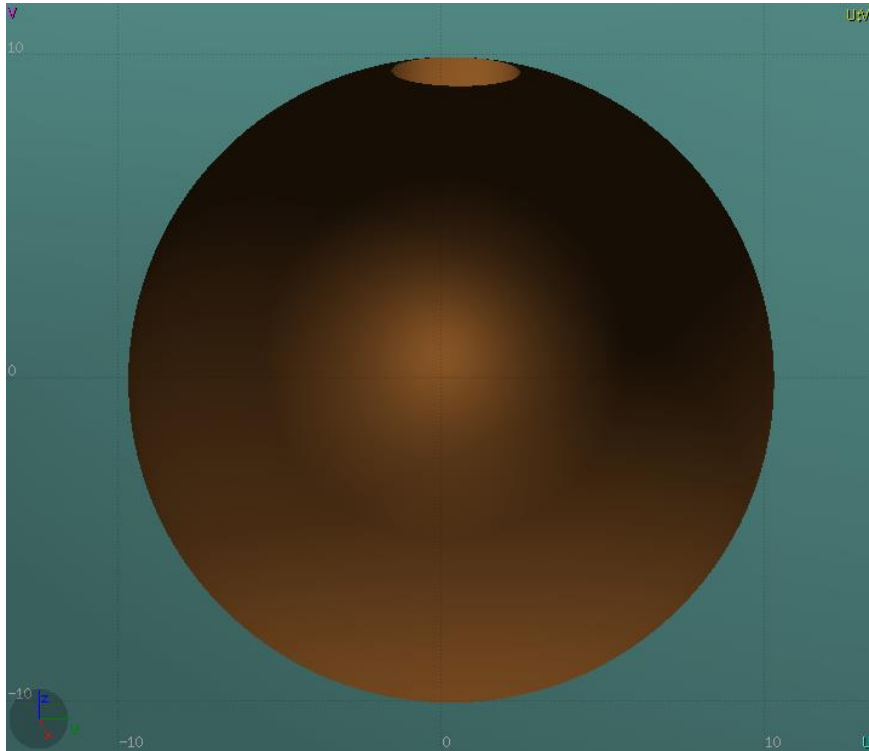

- First, create all necessary bodies: sphere, infinite cylinder, tilted plane

# Zone editing – Example [2/9]

Reference image

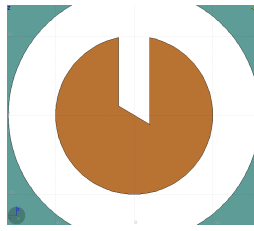

- Add a new region
  - [Space] →  REGION
  - Shortcut [R]
- The region expression is empty
- Type the region name
- Select the material (or leave default VACUUM)
- Press [ESC]
- The region remains selected

# Zone editing – Example [3/9]

- Add the sphere to the selection
  - Holding [CTRL] pressed
- The sphere outline is highlighted
- The sphere divides the space into 2 zones:
  1. **+sphere** (inside the sphere)
  2. **-sphere** (outside the sphere)

Reference image

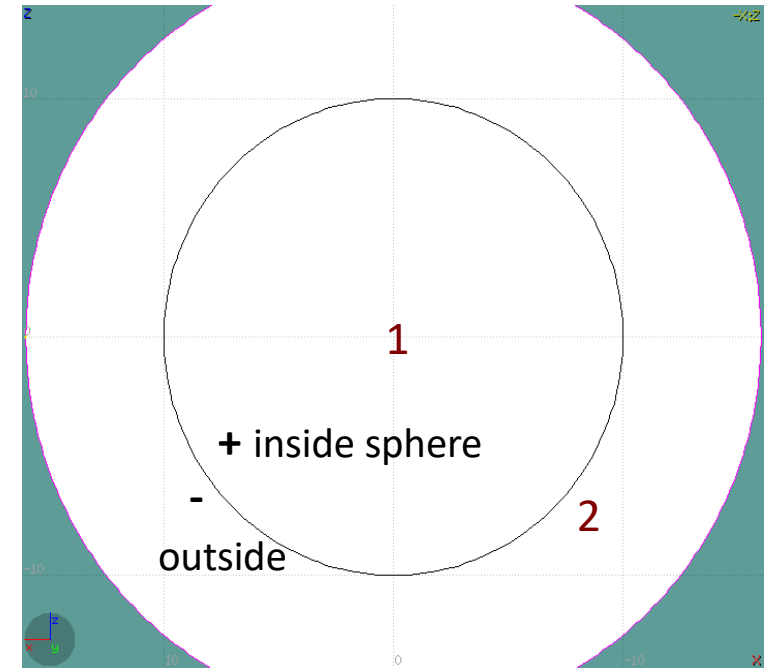
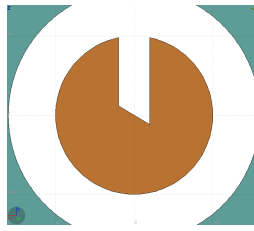

# Zone editing – Example [4/9]

- Add the cylinder to the selection
  - Holding [CTRL] pressed
- The cylinder outline is highlighted
- The sphere and the cylinder

divide the space into 4 zones:

1. **+sphere +cylinder** (inside the sphere, inside the cylinder)
2. **+sphere -cylinder** (inside the sphere, outside the cylinder)
3. **-sphere +cylinder** (outside the sphere, inside the cylinder)
4. **-sphere -cylinder** (outside the sphere, outside the cylinder)

Reference image

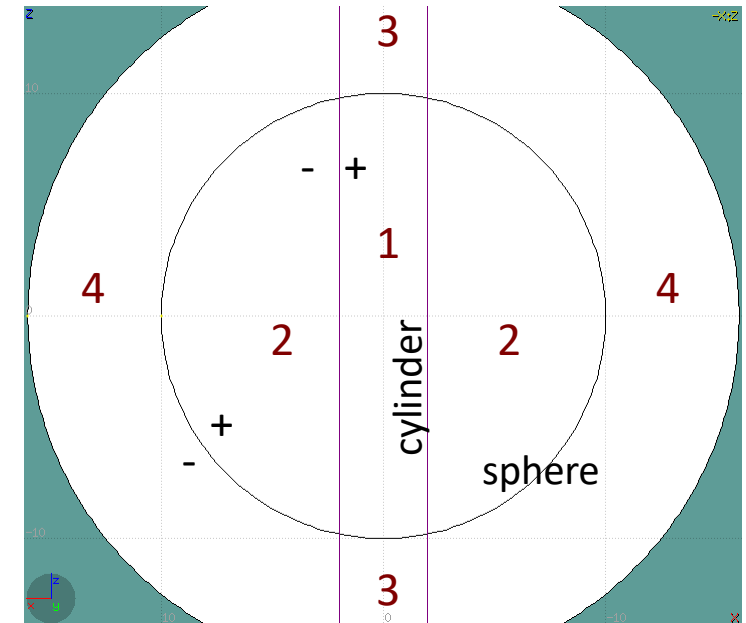
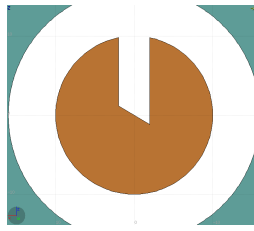

# Zone editing – Example [5/9]

- Add the tilted plane to the selection
  - Holding [CTRL] pressed
- The tilted plane outline is highlighted
- The 3 bodies divide the space into 8 zones:
  1. +sphere +cylinder +plane
  2. +sphere +cylinder -plane
  3. +sphere -cylinder +plane
  4. +sphere -cylinder -plane
  5. -sphere +cylinder +plane
  6. -sphere +cylinder -plane
  7. -sphere -cylinder +plane
  8. -sphere -cylinder -plane
- Number of valid zones  $\leq 2^{\text{bodies}}$

Reference image

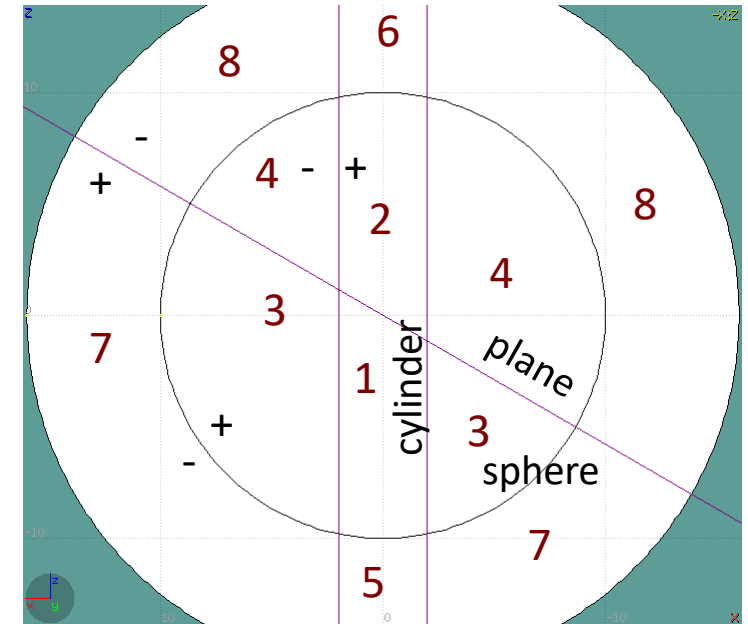
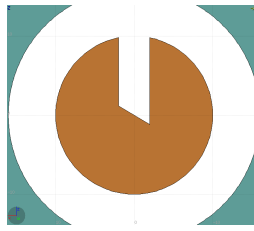

# Zone editing – Example [6/9]

- Press [d] to define the zone
- While moving the mouse, the various subdivision of the space are shown
- Click inside zone 4
- Automatically, the zone expression  
`+sphere -cylinder -plane`  
will be added to the region definition

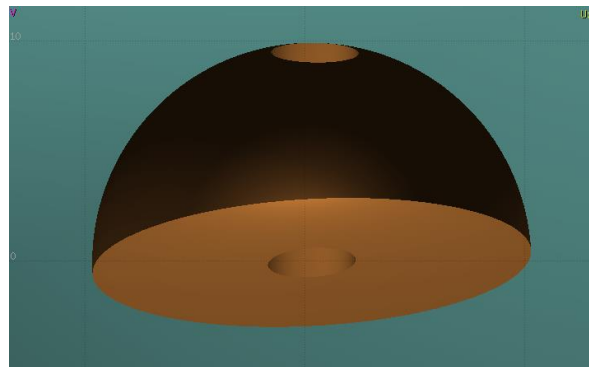

Reference image

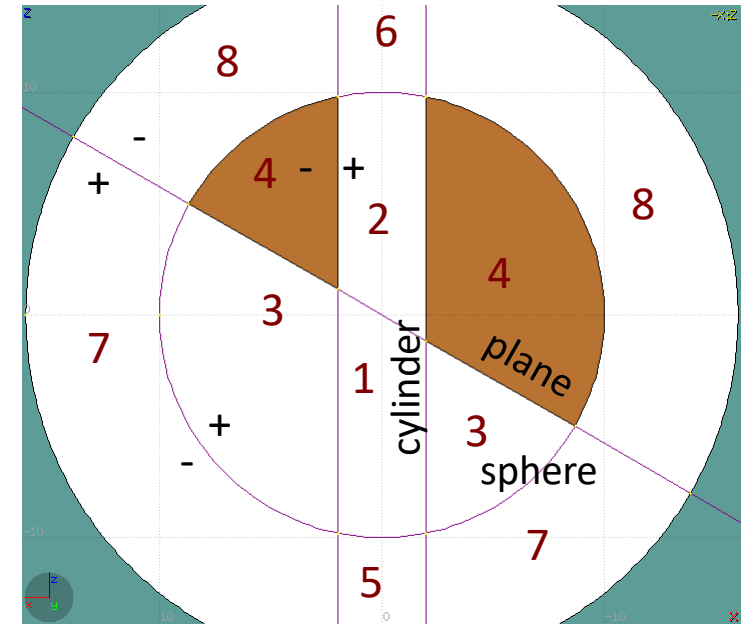
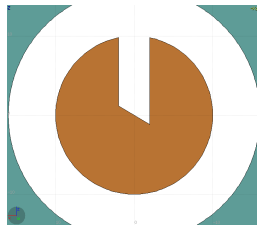



# Zone editing – Example [7/9]

- Adding the bottom part of the sphere
- Press [ESC] to unselect the bodies while keeping the region selected
- Select the sphere and the plane
- Space is divided in 4 zones
  1. +sphere +plane
  2. +sphere -plane
  3. -sphere +plane
  4. -sphere -plane

Reference image

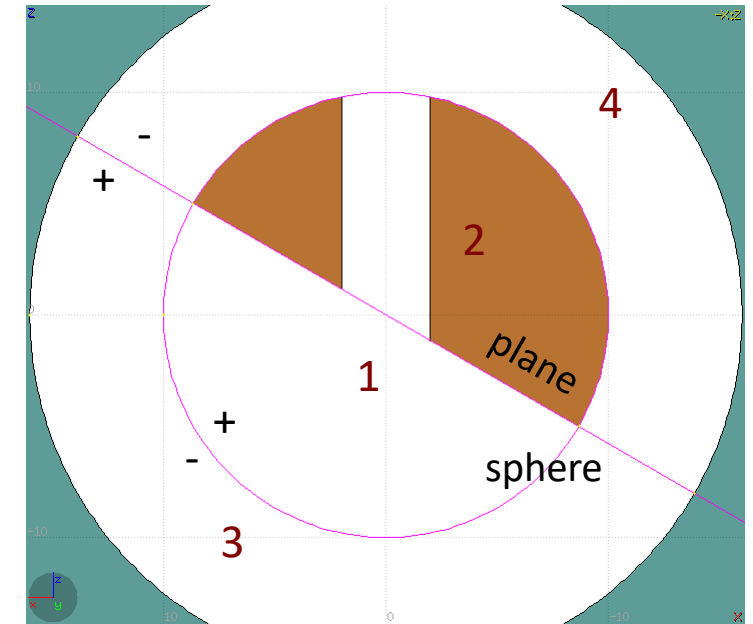
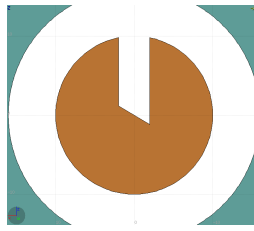

# Zone editing – Example [8/9]

- Press [d] to define the zone
- Click inside zone 1
- Automatically, the zone expression

+sphere +plane

will be appended to the region definition

Reference image

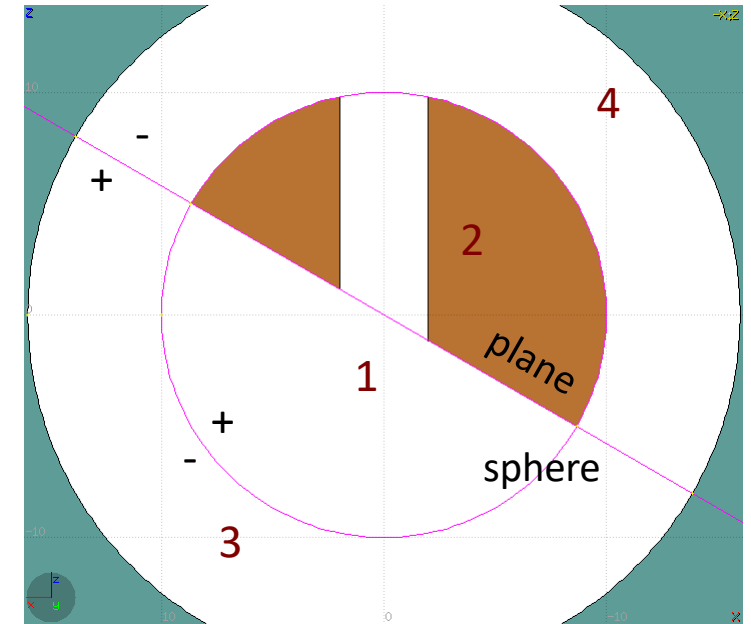
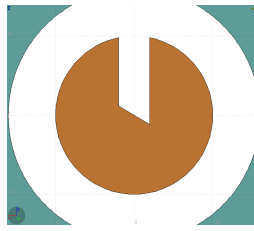

# Zone editing – Example [9/9]

- Press [d] to define the zone
- Click inside zone 1
- Automatically, the zone expression

+sphere +plane

will be appended to the region definition

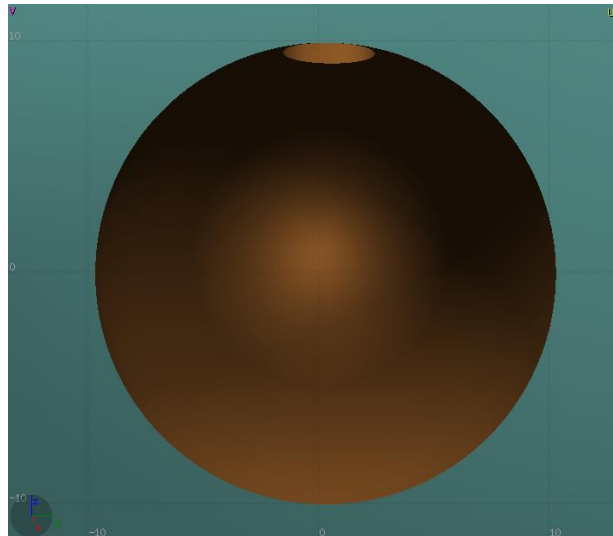

Reference image

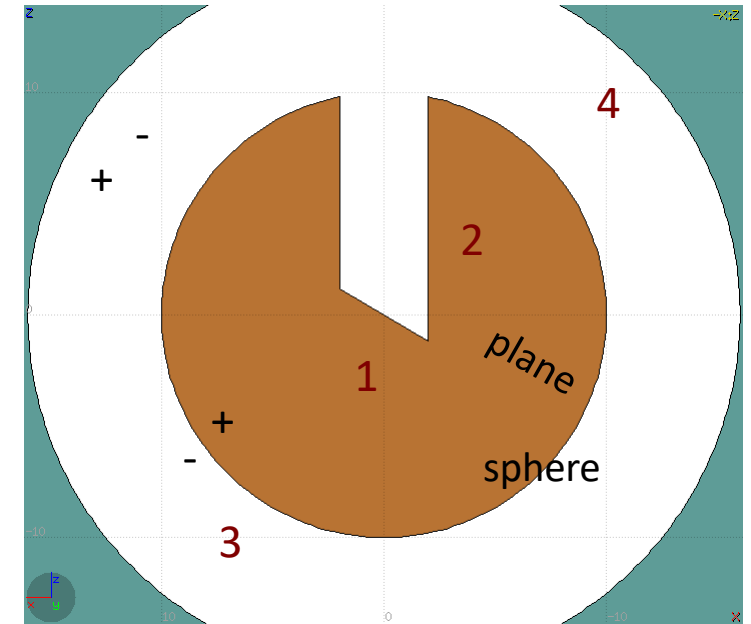
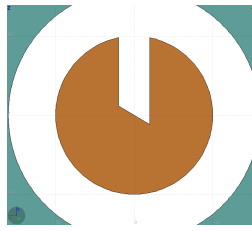

# Summary: Region and Zone editing

- Golden sequence
  1. Select the REGION
  2. Select the zone to modify or none to add a new one
  3. Add to the selection the bodies needed for the zone definition
  4. Define a zone with [d] or right-click on “ Zone”
  5. Move the mouse over a point that belongs to the zone to be and left-click
- Repeat the sequence as many times as needed

# Summary: Region and Zone editing

- The selection shall contain
  1. The REGION to edit
  2. Optionally, the zone to be modified
  3. The bodies representing the boundaries of the zone to be defined
- The selection shall not contain any unnecessary body  
because extra bodies mean extra operations and slower simulations

# ESCape

- [ESC] will stop/unselect in the following order, one item at a time:
  1. Stop the current action, e.g. during rotation
  2. If a zone is selected, unselect the zone
  3. Unselect any selected body
  4. Unselect any selected region

# Debugging Geometry Errors

- The “**Errors found**” message indicated that there are errors on the current projection
- Areas affected by errors are outlined with a **red line**
- Areas filled with a full color correspond to overlapping region
- Areas dashed with red lines correspond to missing region definition
- Body segments involved in the errors are numbered

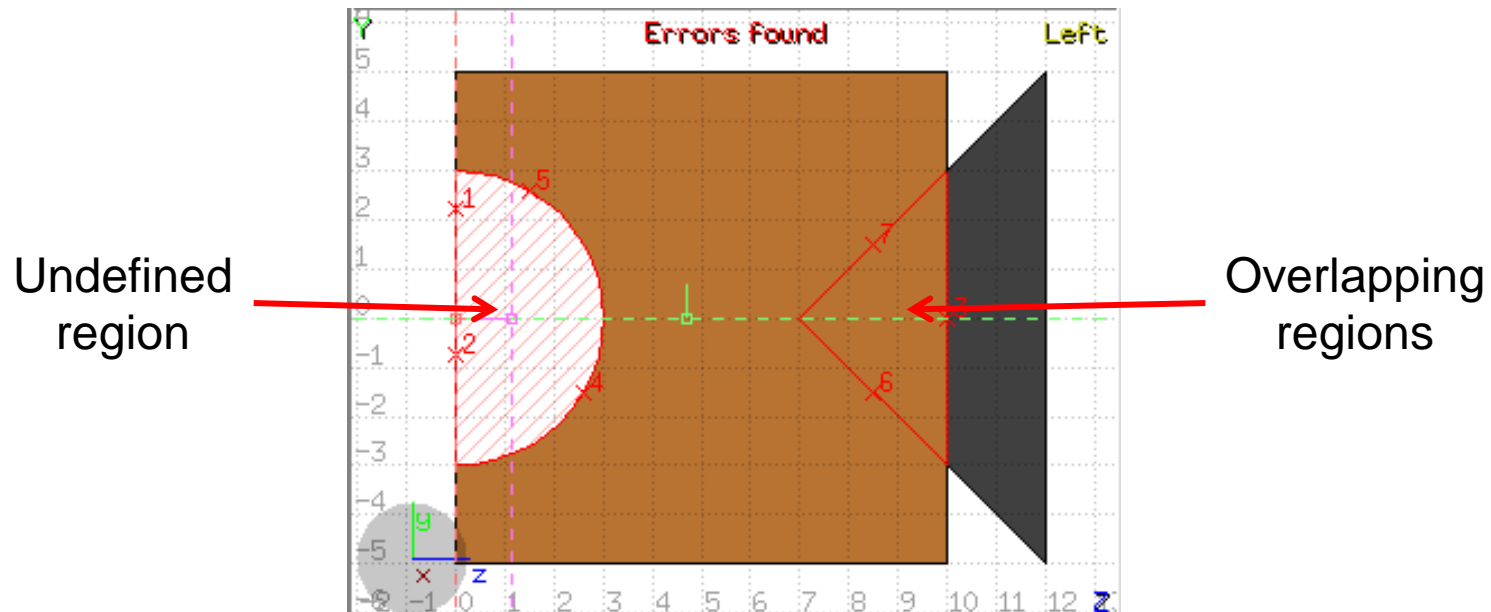

# Debugging Geometry Errors

- Touching surfaces are checked against 10 significant digits
- Non strictly geometrical errors are also notified, e.g.:
  - missing material assignment to a region
  - non-recognized cards
- Clicking on the “ Errors” tab (on the left) displays the recognized errors

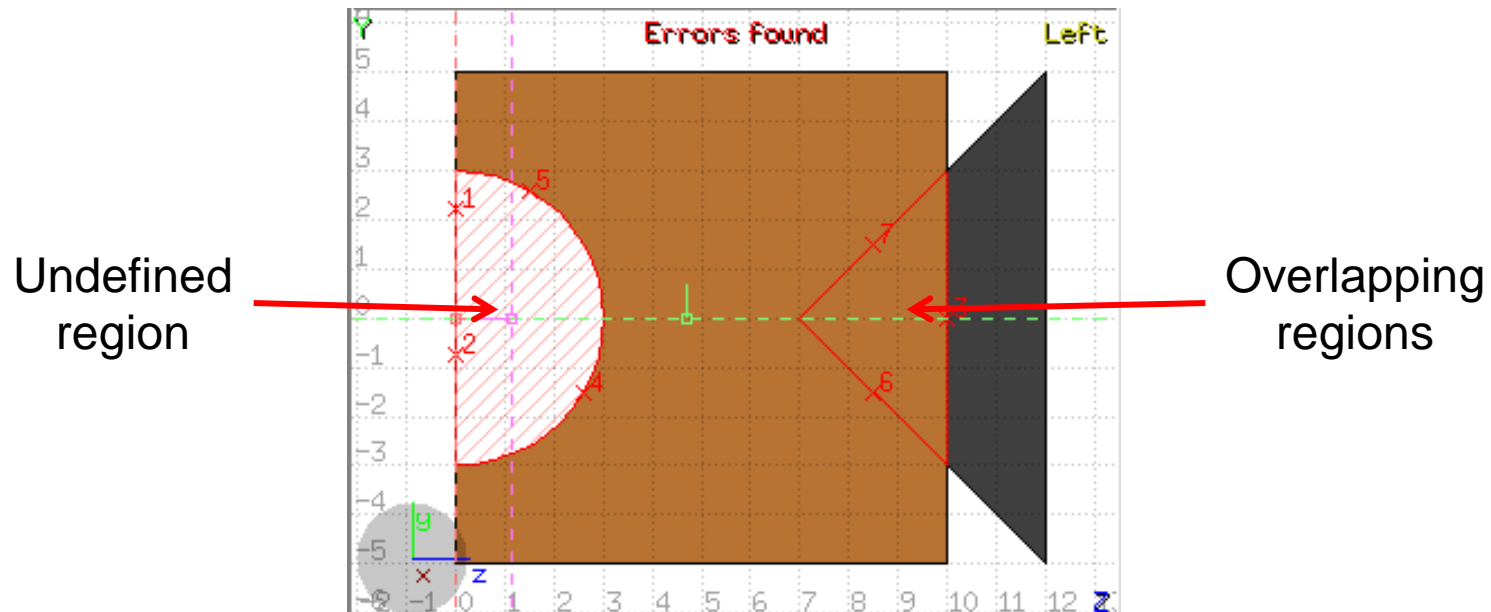



# Geometry Errors Tab

- +n error index in the viewport  
[click](#) to expand and get more info
- x, y, z position of the error  
[click](#) to zoom on the error
- Body body involved in the error
- Reg+ regions on the +side of the body
- Reg- regions on the -side of the body
- Errors [click](#) to focus on the problematic card
- Warnings [click](#) to focus on the problematic card

▼ Red [5]			
+ 1:	0.	0.	2.0
+ 2:	-1.5	0.	8.5
+ 3:	0.	0.	0.
+ 4:	1.5	0.	8.5
- 5:	0.	0.	10.0
Body: target			
Reg+: VOID:2			
Reg-: TARGET:1,VOID:2			
▼ Green [5]			
+ 1:	0.	0.	2.0
+ 2:	0.	0.	0.
+ 3:	-1.5	0.	8.5
+ 4:	0.	0.	10.0
+ 5:	1.5	0.	8.5
▼ Blue [5]			
+ 1:	0.	0.	0.
+ 2:	0.	-0.46729	7.46729
+ 3:	0.	0.46729	7.46729
+ 4:	0.	0.	10.0
+ 5:	0.	0.	2.0
▼ Magenta [3]			
+ 1:	1.941187	-0.48145	0.
+ 2:	-2.0	0.	0.
+ 3:	1.941187	0.481447	0.
▼ Input [Errors:1, Warnings:1]			
Errors:			
1: Region 'F00' empty expression			
Warnings:			
1: Region 'F00' is not assigned any material			

**Spare slides**

# Navigation with the keyboard

- *[arrows]* pan viewport
- **Ctrl + [arrows]**  
+ **[Shift]** orbit viewport around **u,v** axes  
rotates by 90°
- **Page Up/ Page Down** pan viewport front/back
- **Ctrl + PgUp/PgDn** rotate viewport around **w** axis
- **= / -** zoom in / zoom out
- **o** open projection dialog to set the  
**o** origin/basis/save/recall etc...
- **Ctrl-0 (zero)** Center to origin
- **C-1, C-2** **front [X:Y] / back [-X:Y]**
- **C-3, C-4** **left [Z:Y] / right [-Z:Y]**
- **C-5, C-6** **top [Z:X] / bottom [-Z:X]**

*Assuming:*

*Z = direction of the beam (horizontal)*





*X = horizontal*

*Y = vertical*

# Navigation with the mouse

With the **left** mouse button:

1. Select the appropriate action pan/orbit/zoom with:
  - I. Menu → Tools
  - II. Toolbar
  - III. Keyboard shortcut
2. Click and drag the desired viewport

	function	key	description
	Pan	<b>x</b>	Pan viewport
	Orbit	<b>t</b>	Orbit viewport using a virtual <b>t</b> rackball
	Zoom	<b>z</b>	Drag area to <b>z</b> oom In ([ <b>Ctrl</b> ] to zoom out)
		<b>Shift-Z</b>	Zoom viewport on selected items
		<b>Alt-Left</b>	Go to previous in history projection
		<b>Alt-Right</b>	Go to next in history projection

# Navigation with the mouse

- With the **middle** mouse button
  - alone Pan/Move viewport
  - **Ctrl** orbit projection using a virtual trackball
  - **Ctrl-Middle-Shift** orbit projection using a virtual trackball with steps of 15 degrees
  - **Shift** select rectangle region and zoom into
  - **Shift-Middle-Ctrl** select rectangle region and zoom out
- **Wheel** (if any) zoom in/zoom out
  - **Ctrl-Wheel** pan/move forward or backward
  - **Ctrl-Shift-Wheel** smoother pan/move forward/backward
- With the **right** mouse button
  - alone opens popup menu
  - **Shift** pan/move viewport
  - **Ctrl** orbit projection using a virtual trackball

 When **laptop mode** is enabled in the Preferences/Geometry then the **middle** and **right** buttons are **swapped**

