EFFICIENCY AND TIME RESOLUTION OF A THIN GAP RESISTIVE CYLINDRICAL CHAMBER

A. ROCCHI, B. LIBERTI, M. SESSA

The background features a simulation of particle tracks in a detector, with a city skyline silhouette in the background. The tracks are colorful (red, orange, yellow, blue) and radiate from a central point. The city skyline includes a prominent cathedral with two towers.

Santiago de Compostela
(Spain)

RPC
2024

WHAT IS A RESISTIVE CYLINDRICAL CHAMBER (RCC)

- The RCC detector is a new gaseous detector introduced by R. Cardarelli in 2020 - 2022.

[R. Cardarelli, A. Rocchi et al, The Resistive Cylindrical Chamber. NIM Section A. Volume 1058,2024,168822-ISSN 0168-9002]

<https://doi.org/10.1016/j.nima.2023.168822>

- It consists of two cylindrical concentric electrodes of resistive material which define a gas gap.
- Like RPC, HV is distributed on the electrode surface (not facing the gas) through a graphite coating.
 - Pillars are replaced by end-cap spacers or spiraled fishing line.
 - Pick-up readout could be placed both in the internal cavity or on the outer surface.

WHY A RESISTIVE CYLINDRICAL CHAMBER

Mechanical strength

The force exerted on the bonding surfaces of the pillars increases proportionally to the difference in pressure with respect to the outside of the gas volume and with respect to the size of the detector

$$p_{pillar} = \frac{F_N}{n_{pillar} * S_{pillar}} = \frac{\Delta p * S_{detector}}{n_{pillar} * S_{pillar}} \rightarrow \Delta p = 2 \text{ bar} ; S_{detector} = 10 \text{ kcm}^2 ; S_{pillar} = 0,2 \text{ cm}^2 ;$$

The planar geometry is not suitable to be pressurized unless significantly increasing the density of pillars or building a complex mechanical structure that counterbalances internal forces

$$p_{pillar} = \frac{10^2}{n_{pillar}} \text{ kbar}$$

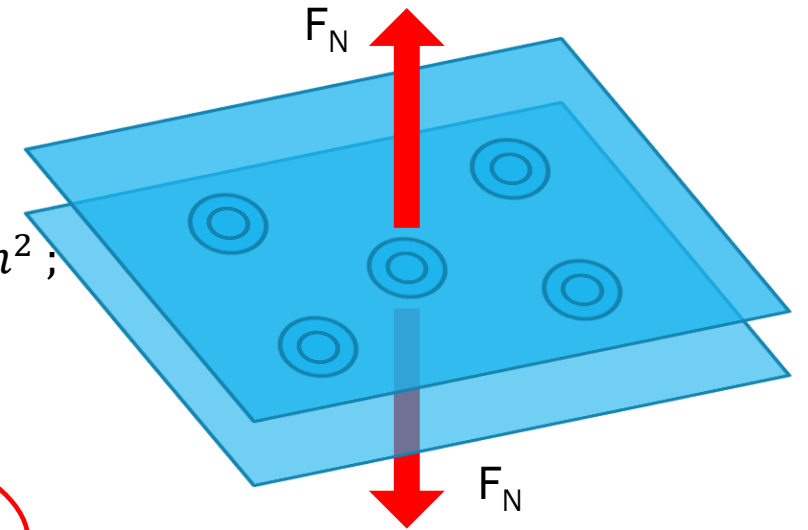

The tensile strength of Bakelite is about 1,2 kbar

Geometry

1. empty cavity for the insertion and integration of other devices such as detectors, sources or beam pipes...
2. redundancy of the active area and readout with respect to secant tracks, increased active area for tangent tracks → self tracking capabilities
3. Electric field gradient drive the avalanche discharge depending on detector structure and polarization

•It is feasible using low-cost components found in commercial catalogue

RCC AT WORK

The field gradient inside the gas gap can be exploited in both polarities.

For the detector design described below the following configurations will be studied:

Positive polarity (applied on the inner cylinder)

- Electrons produced far from the inner electrode are accelerated by a less intense electric field in the first part of the path. With a crude approximation we can describe it as process of **drift followed by multiplication**. High probability that these electrons produce a detectable signal due to the long path.
- Electrons produced near the internal electrode can cover a small path in the gas gap. The more intense electric field produces a greater gain in this region, increasing the gap effective.

Negative polarity (applied on the inner cylinder)

- Electrons produced far from the inner electrode are accelerated by a more intense electric field in the first part of the path. With a crude approximation we can describe it as a **multiplication followed by a drift**. Very High probability that these electrons produce a detectable signal due to the long path and high gain.
- Electrons produced near the external electrode can cover a small path in the gap: furthermore, the field in this region is less intense, so the probability of producing detectable signals is **small reducing the effective gap**.

$$E(r) = \frac{V}{r \ln \frac{R_o}{R_i}} \sim \boxed{\frac{V}{R_i \ln \frac{R_o}{R_i}}} - \frac{V}{R_i \ln \frac{R_o}{R_i}} \frac{r - R_i}{R_i}$$
$$R_o - R_i \ll R_i$$

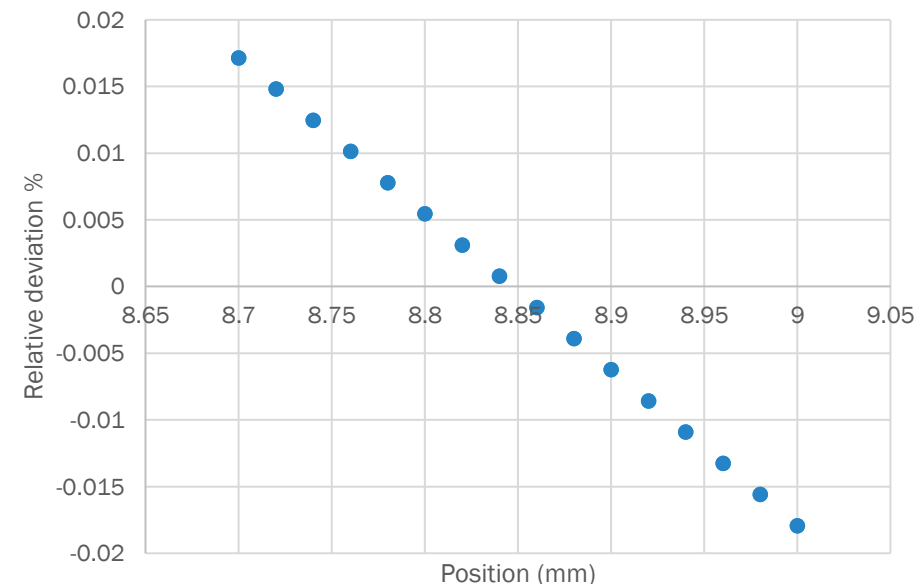
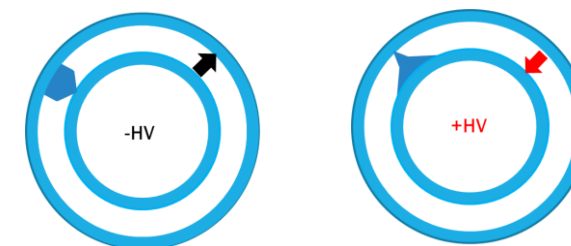

DETECTOR DESIGN

Features:

- Two concentric Bakelite tubes: 15 cm long
- Graphite layer not calibrated in resistivity sprayed on external surfaces (GRAPHIT 33 Spray)
- 7 Strips pick up on the outer surface: 0.8 mm, 1 cm pitch
- 1 Pad pick-up on the inner surface
- Scintillator detector inside the RCC cavity, readout: SIPM Hamamatsu MPPC S14160 series + INFN FE-E board (Tanks to A. Paoloni and G. Felici)
- 0.3 mm gas gap
- Pressure rating up to 6 bar

Weak points:

- Shielding end-caps not ready for the tests
- SIPM power cable inside the cavity.

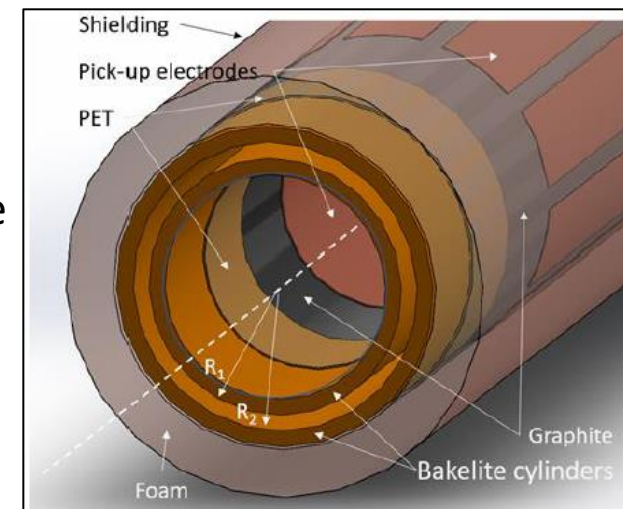
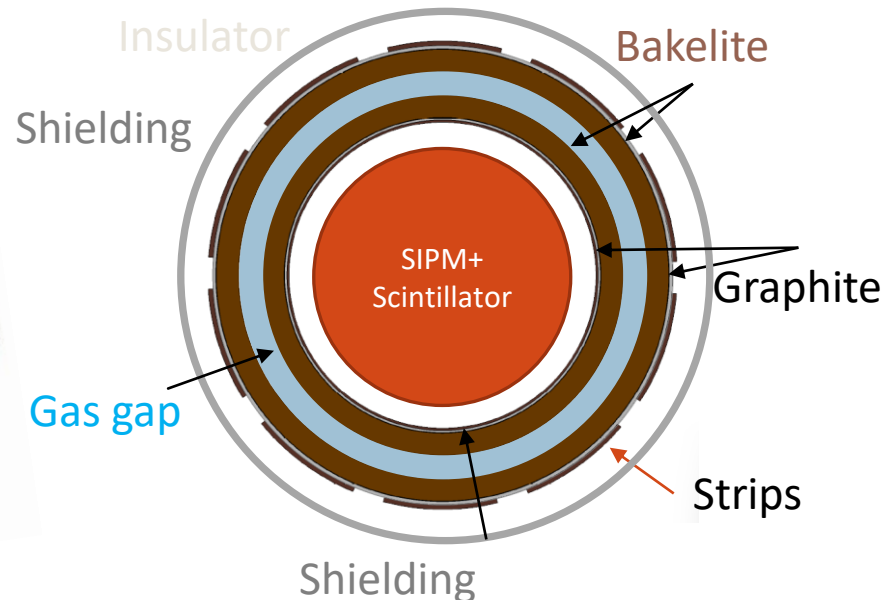
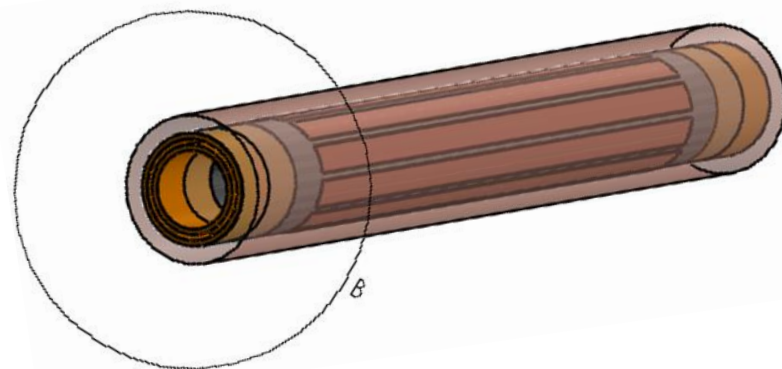
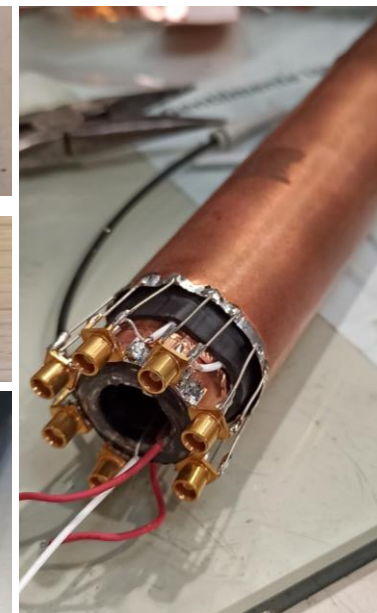

BAKELITE TUBES ELECTRODES

- Bakelite tubes are widely used in the electrotechnical industry, for insulation and insulation. This makes them **easy to find and cost effective (cost around €25/m)**. They are rarely sold with selected resistivity.
- Tubes used in this test were purchased from the CERN store, where different formats are available.
- **The internal and external surfaces have different properties:** the inside is polished, the external is rough.
- To obtain the desired gas-gap thickness, the internal tube was machined. The residual surface roughness was smoothed and treated with linseed oil. **Macroscopic difference in the quality of the two surfaces.**
- Inner tube:
 - Thickness 0.77 mm
 - External diameter 17.4 mm
- Outer tube
 - Thickness 1 mm
 - Internal diameter 18 mm
- **The resistivity of the electrodes was measured with an Argon scan**
- The Ohmic current is almost comparable to the current in the gas! (technical problem)

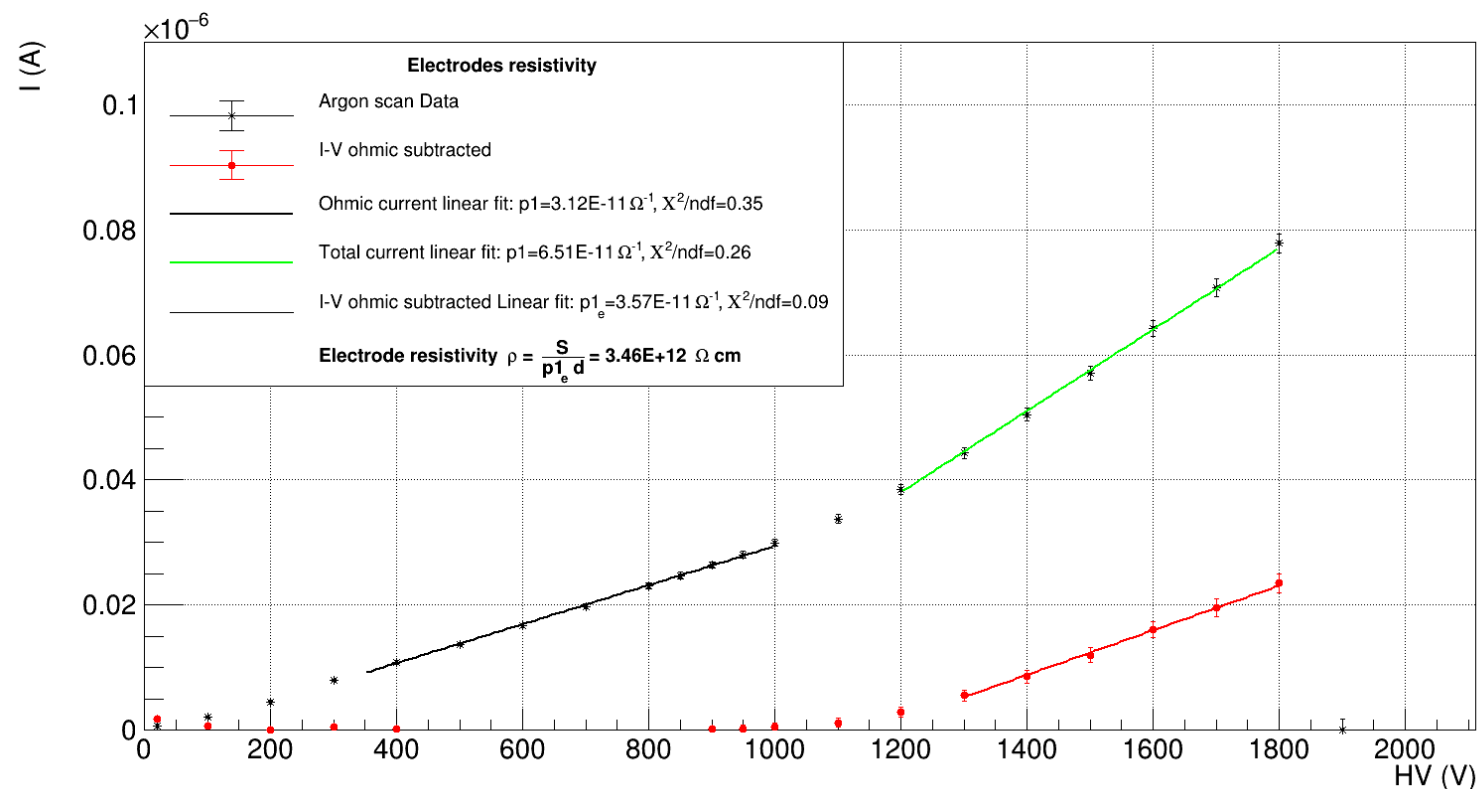

EXPERIMENTAL AREA AND SETUP

H8 line:

180 GeV/c muons beam;

The test was carried out in two positions:

Platform PPE168, behind the beam dump platform.

Two beam configurations:

- Primary muon beam (23 mm x 23 mm RMS),
- Dumped pions beam (spread).

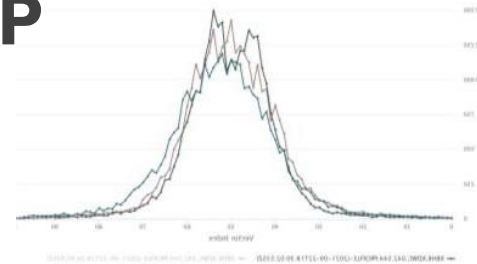

Beam profile
From wire chambers

Voltage supply	3–5 Volt
Sensitivity	2–4 mV/fC
Noise (independent from detector)	4000 e ⁻ RMS
Input impedance	100–50 Ohm
B.W.	10–100 MHz
Power consumption	10 mW/ch

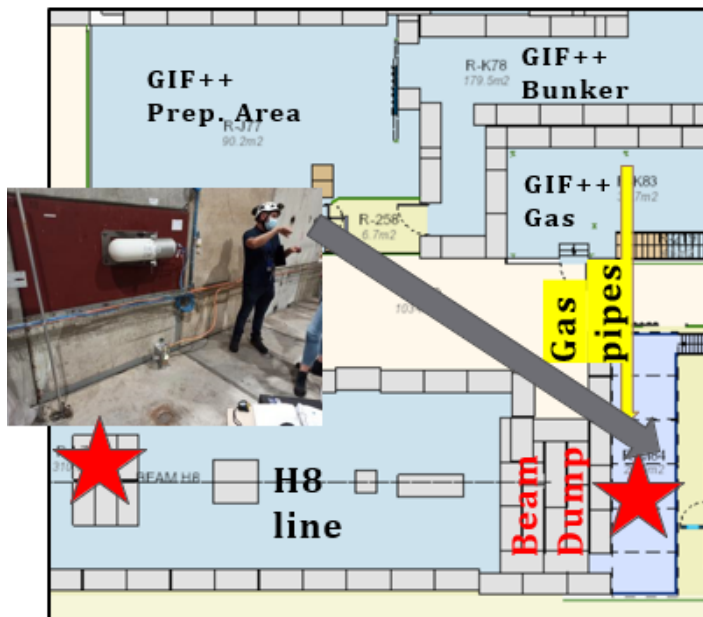

- Gas lines:
94.7% TFE + 5% iC4H10+0.3%SF6
CO2 gas line from H8 gas rack
- DAQ System:
CAEN V1718 USB Bridge
CAEN V1742 32 Ch Digitizer
- Trigger System:
Logic & between RD51
Protov 4 x 2 cm² Cerenkov detector

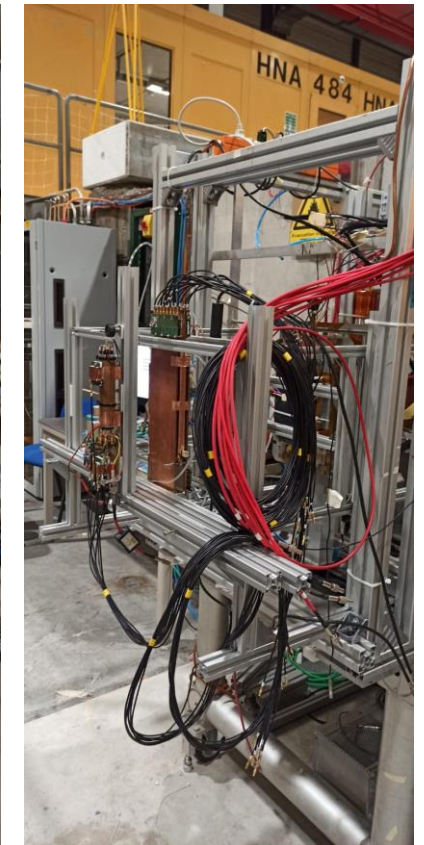
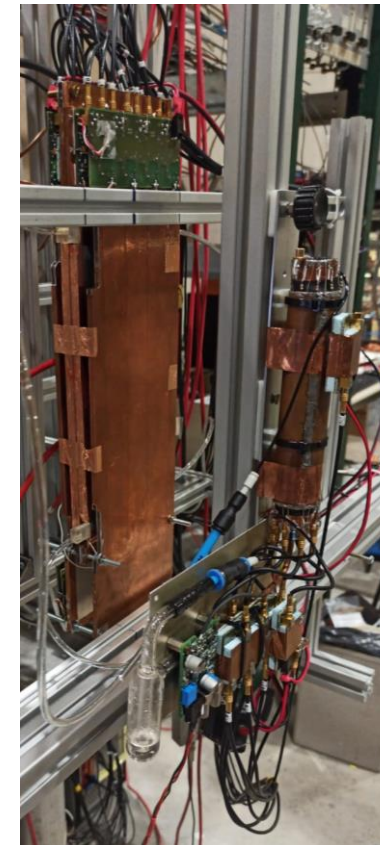

DATA REJECTION

- Pedestal amplitude distribution shows long tails up to 100 mV
- Amplitude spectrum profile highlight the pick centered at 30 MHz
- Cause of the problem seems to be the SIPM power cable entering the RCC cavity.
- **No refined algorithm for noise suppression are applied, signals are not filtered**
- **Threshold set to balance fake probability in the search window and event rejection**
- Events where signal crosses the threshold before the search window are discarded

Pedestal window = 220 ns
 Search window = 50 ns
 $P_{50ns}(n>1, 0.026) = 0.025$

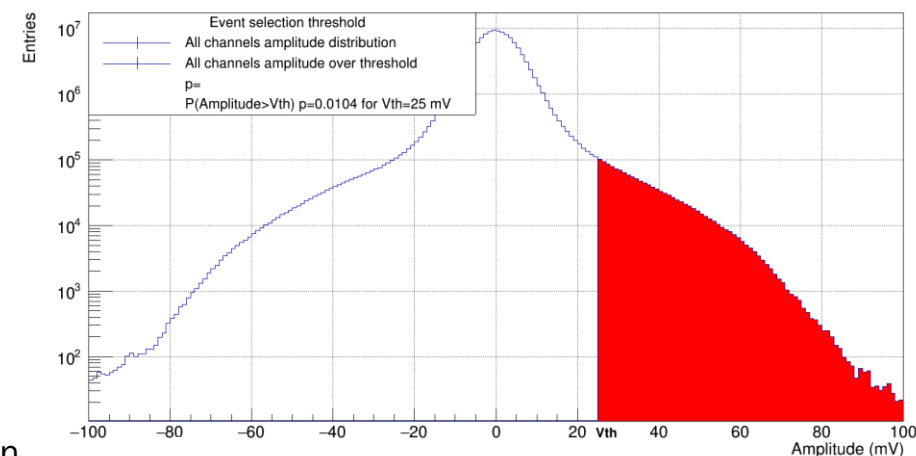
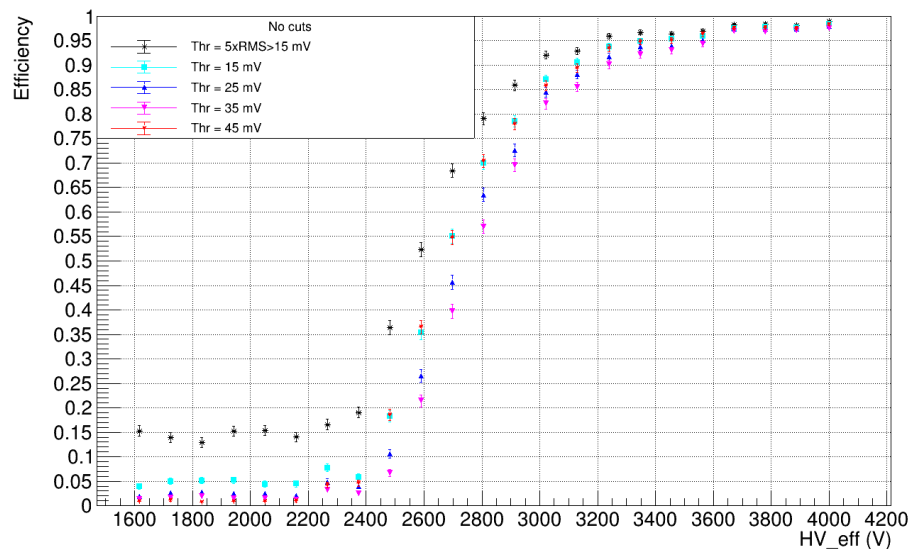

Typical noise oscillation

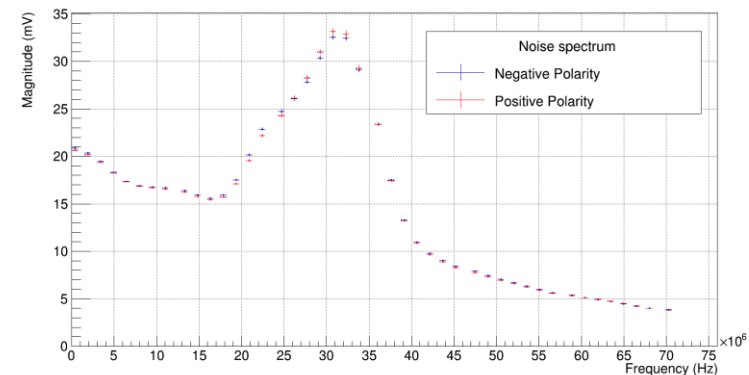
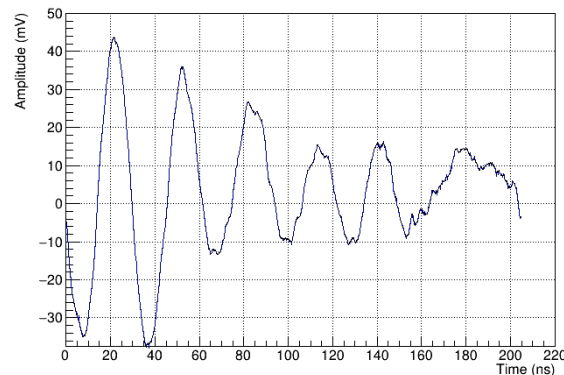

EFFICIENCY FOR DIFFERENT POLARIZATION

- Efficiency measured at different fixed thresholds for both polarities.
- **Positive polarity: avalanche discharge moves towards the internal electrode encountering more intense field in the final steps**
- **Negative Polarity: avalanche discharge moves towards the external electrode encountering less intense field in the final steps**
- Efficiency scan have been performed three times switching polarity to evaluate hysteresis effects. First and second curves in positive polarities are perfectly consistent.

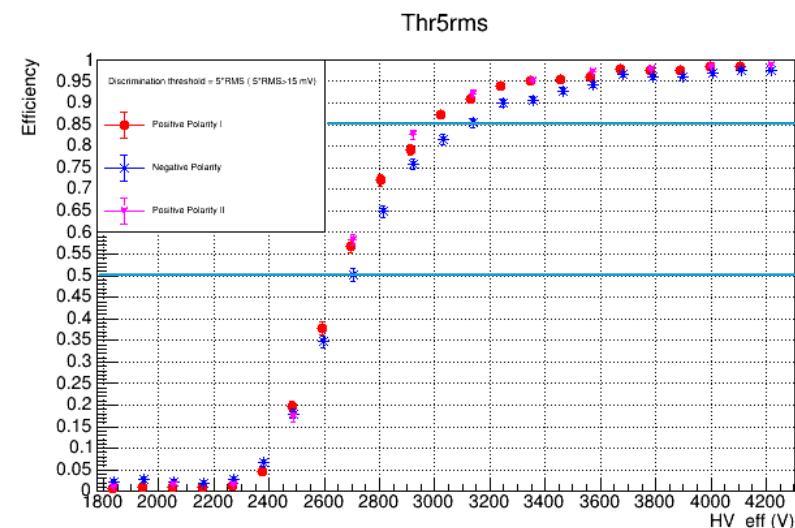
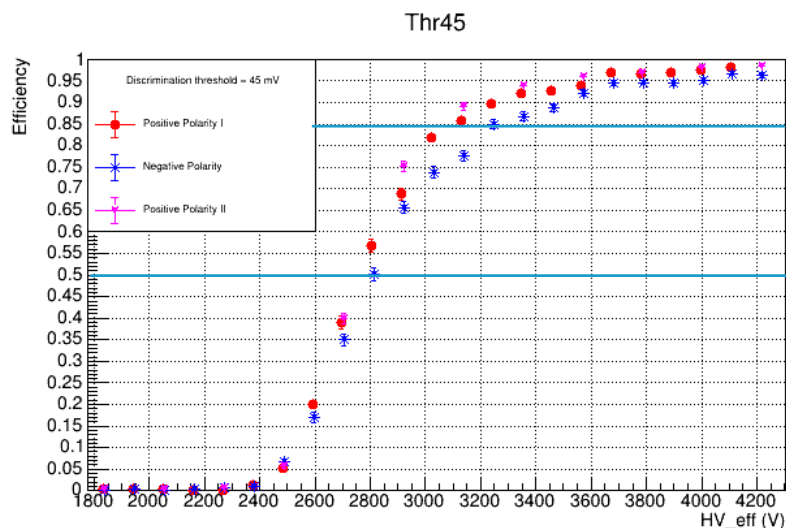
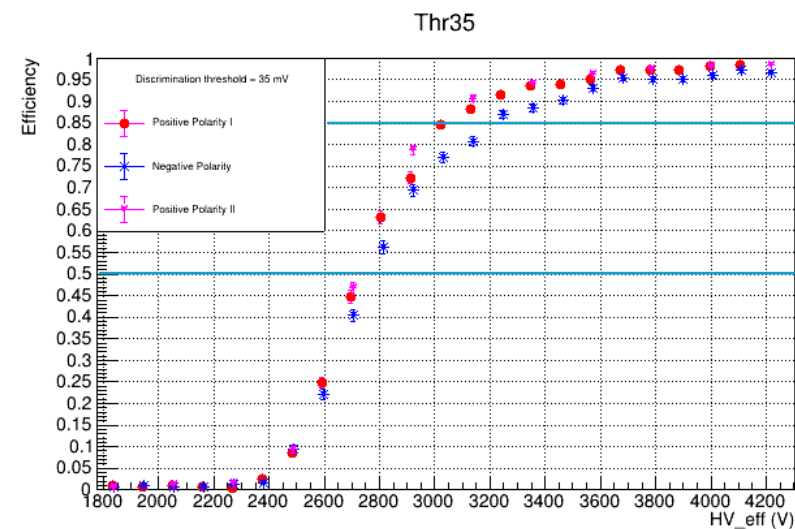
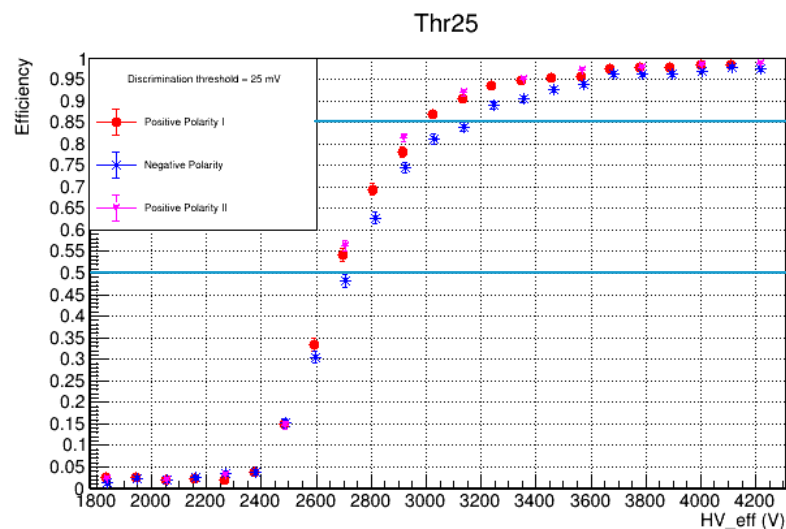
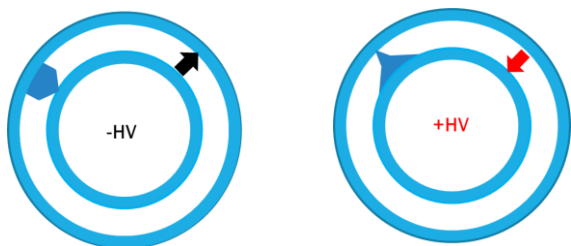

MORE ON EFFICIENCY

Negative polarity is systematically less efficient. Discrepancy is observed regardless of the discrimination threshold .

- The FE electronics have asymmetric dynamics: the observation could be traced back to a systematic effect due to a lower sensitivity in negative polarity. (We know this is not the case!)
- Signals on the external strips and on the internal pick up are of opposite polarity for any polarization → The efficiency measurement on the internal pick-up confirms the trend observed with the external strips. Inefficiency does not depend on the response asymmetry of the FE.
- The probability of random events, after applying the cuts, is less than 0.01, well below the observed excess efficiency!

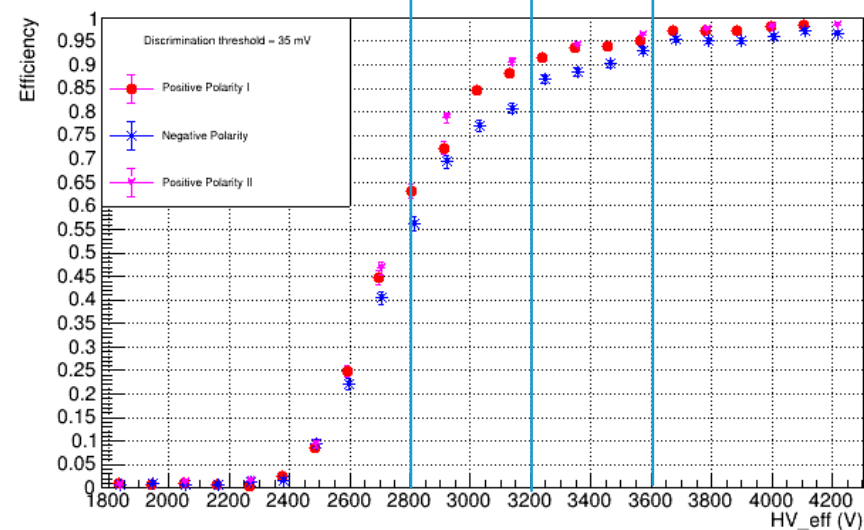
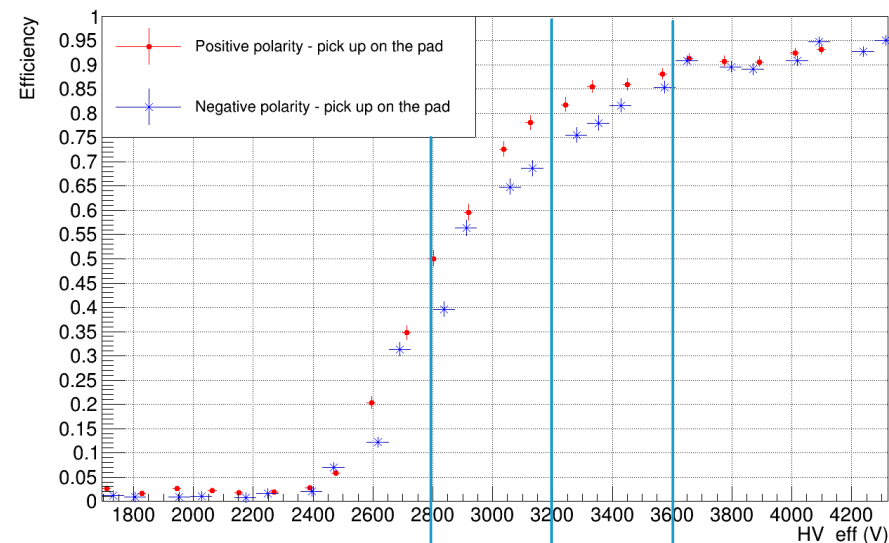
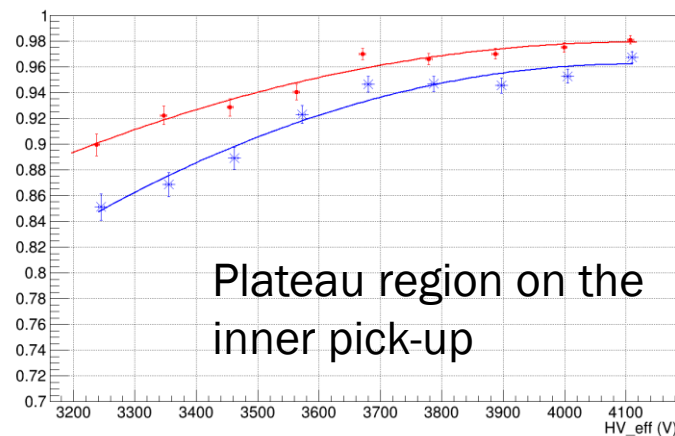
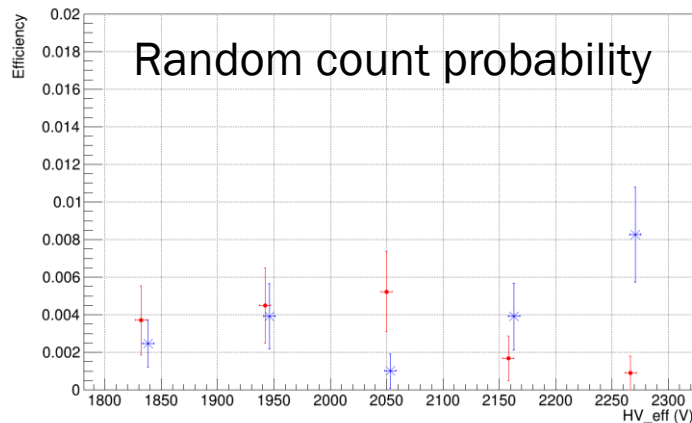

AMPLITUDE DISTRIBUTION AND EFFICIENCY MAP

- The cylindrical geometry can be optimized to identify the direction of the incident particle.
- The internal scintillator selects only the particles that pass through the cavity. **Three cases can be observed: a cluster upstream, a cluster downstream, two clusters. Cluster position is expected to be diametrically opposite along the beam direction.**
- The asymmetric dynamics of FE electronics is clearly observed in the amplitude distributions. Positive signals saturate above 450 mV, negative signals saturate below 130 mV.
- here, in addition to the FE-E saturation the negative polarity produces a fraction of saturated events already at low efficiency (streamers?).

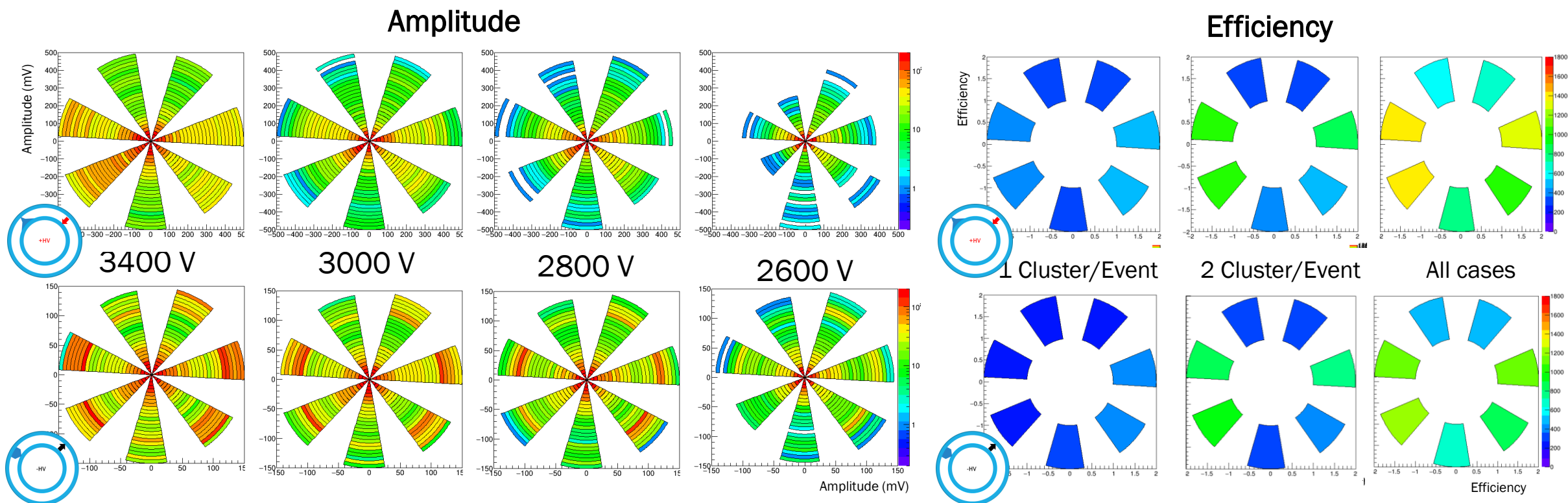

TIME RESOLUTION

- Time resolution was estimated through time-of-flight measurement with respect to external reference.
- **As a reference, the times above the threshold at 10% of the maximum Amplitude signals of two 0.2 mm RPC detectors have been averaged. (145 ps for single detector)**
- Time when signals cross threshold set at 10% of maximum amplitude has been measured
- No time walk correction.
- Time of the leading channel in the cluster was selected, requiring that all the selected clusters were on the same side with respect to the direction of the beam
- **Time jitter has an almost constant trend on the plateau for both polarities.**
- **The observed value is comparable with the jitter of the time-of-flight measured between the two reference detectors.** Probably the experimental setup (readout system, reading pick-up, skew...) does not allow better results to be obtained!

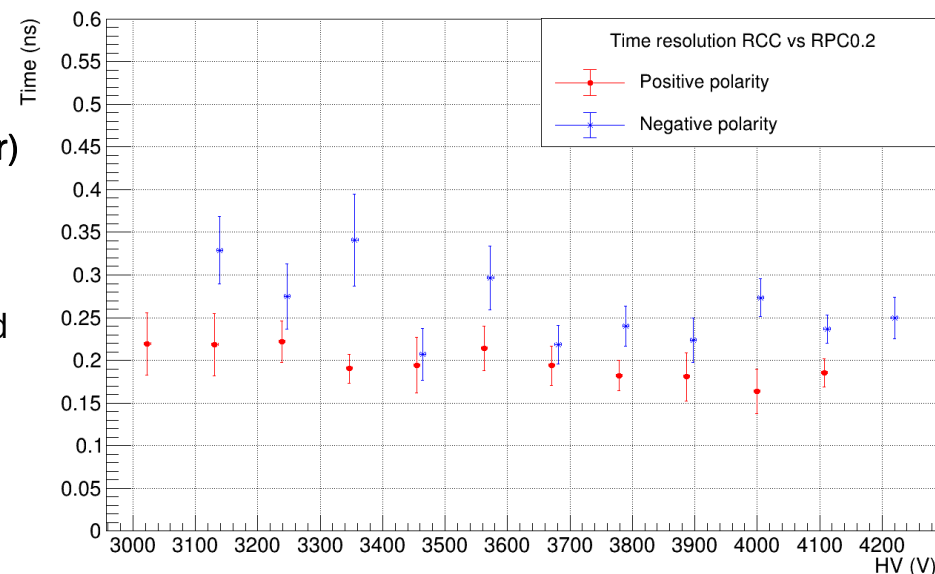

All channels all operating point in the plateau

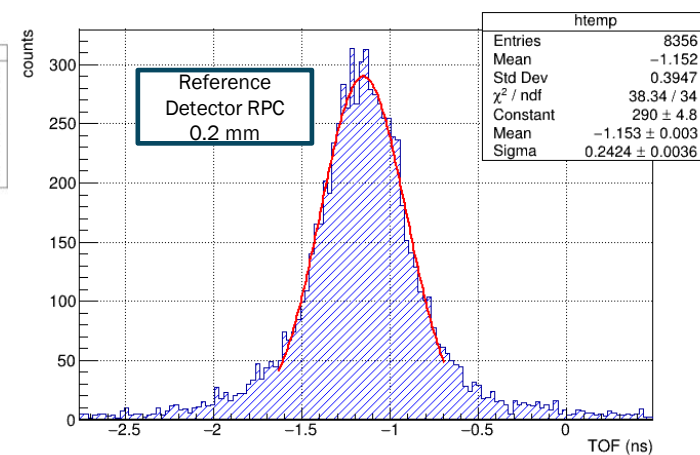
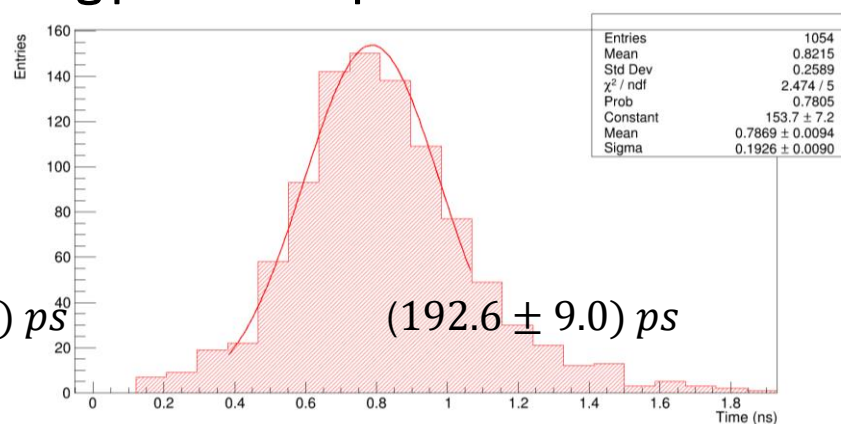
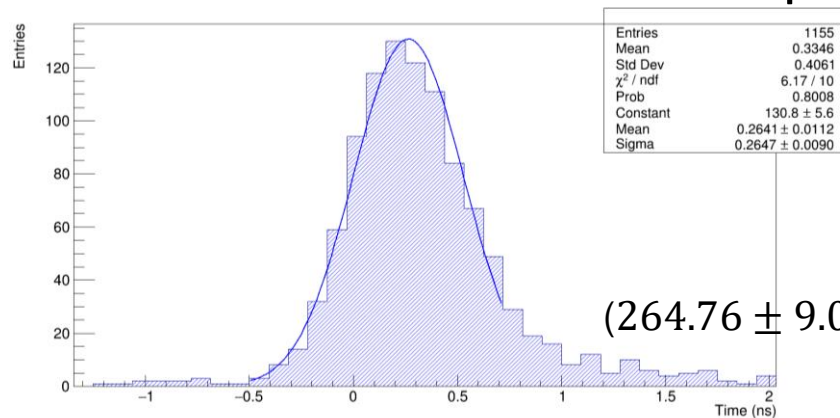

SOME TRIALS WITH PURE CO2

- RPCs work at atmospheric pressure with a non pressurizable gas mixture; given the lack of mixers we connected the safest and easy gas to find.
- Pure CO2 was flushed at a pressure of +3Bar
- The extremely high ohmic current together with the increase in voltage and charge produced in the gas made the detector unstable, as expected.
- High electrodes resistivity made voltage drop significant.
- **This did not prevent us from revealing coincidences and sketching an efficiency curve.**
- This is the first step to transition to a new pressurized mixture, hopefully eco-friendly.
- Argon conditioning will be performed to reduce the

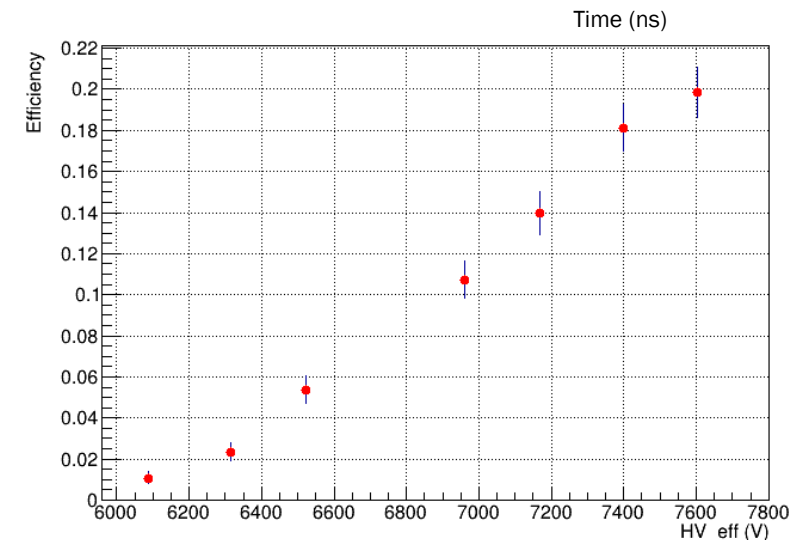
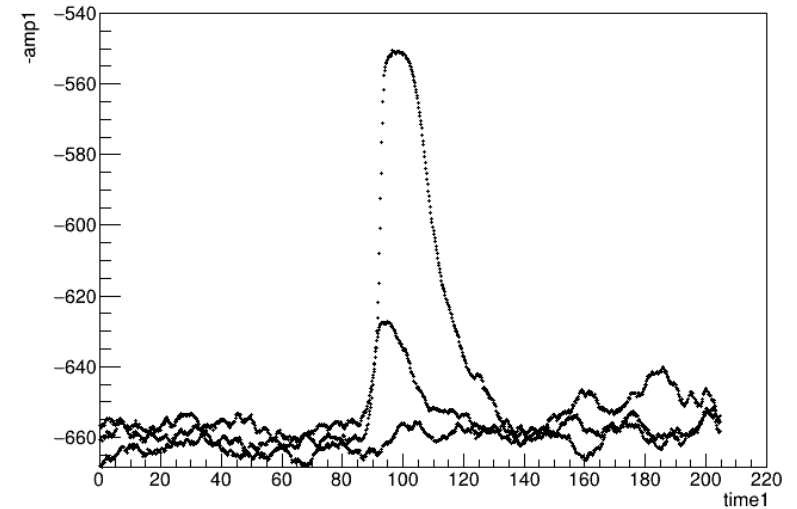

CONCLUSIONS

- In the last 4 years the RCC was introduced, and the functionality of the detector has been tested with prototypes of different design (1 mm gas-gap, 0.3 mm gas-gap...)
- **Today we presented a high-performance device with multi-channel read-out, capable of being pressurized.**
- In addition to being a valid tool to study the dynamics of the discharge in this operating regime and in the different polarities, the proposed detector has established solid performances:
 - **Efficiency up to 98%**
 - **Time resolution well below 200 ps with intrinsic bi-gap configuration**
 - **Tracking capability**
- **despite the thin gap, the electric field gradient, of about 4% appears to produce a detectable asymmetry. This presents a great opportunity to study the physics of the device.**
- Further studies will be conducted by removing the electronics of FE-E, and a measurement of the streamer avalanche ratio will be conducted
- Soon the device will be updated, removing the SIPM from the cavity, and inserting a light guide. This will allow noise to be suppressed and shielding end caps to be inserted



THANKS FOR YOUR ATTENTION



BACKUP-SLIDES

SIGNALS SHAPE

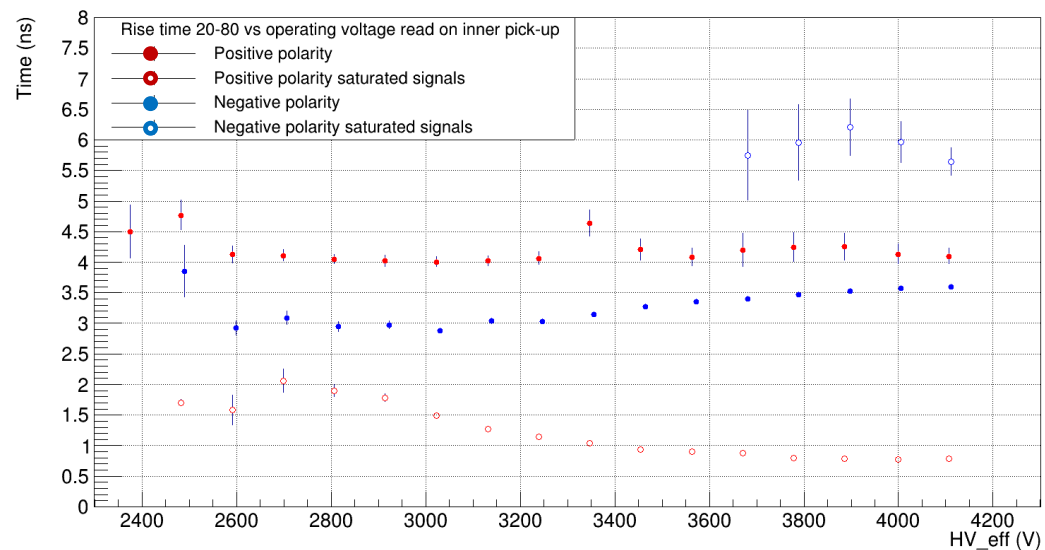
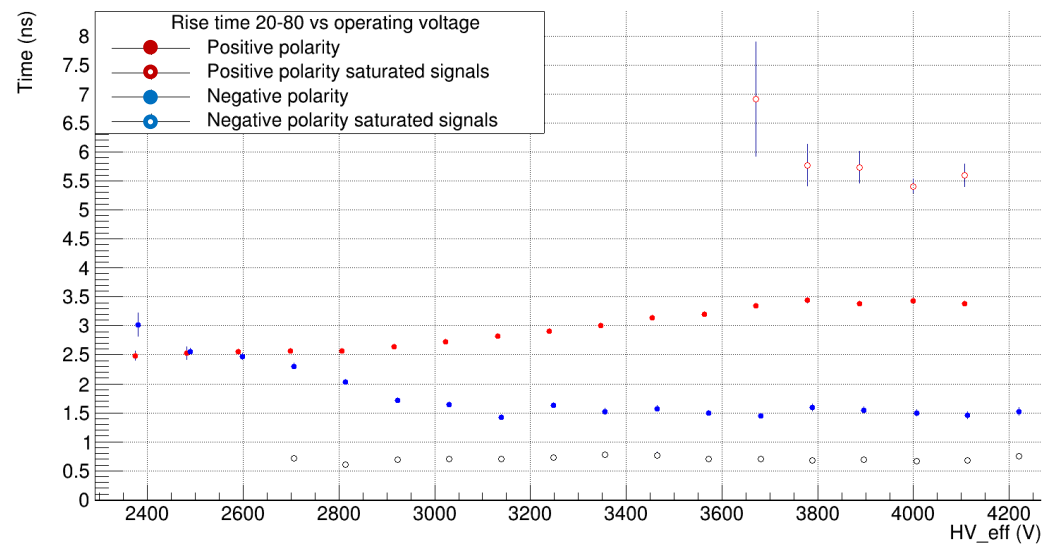
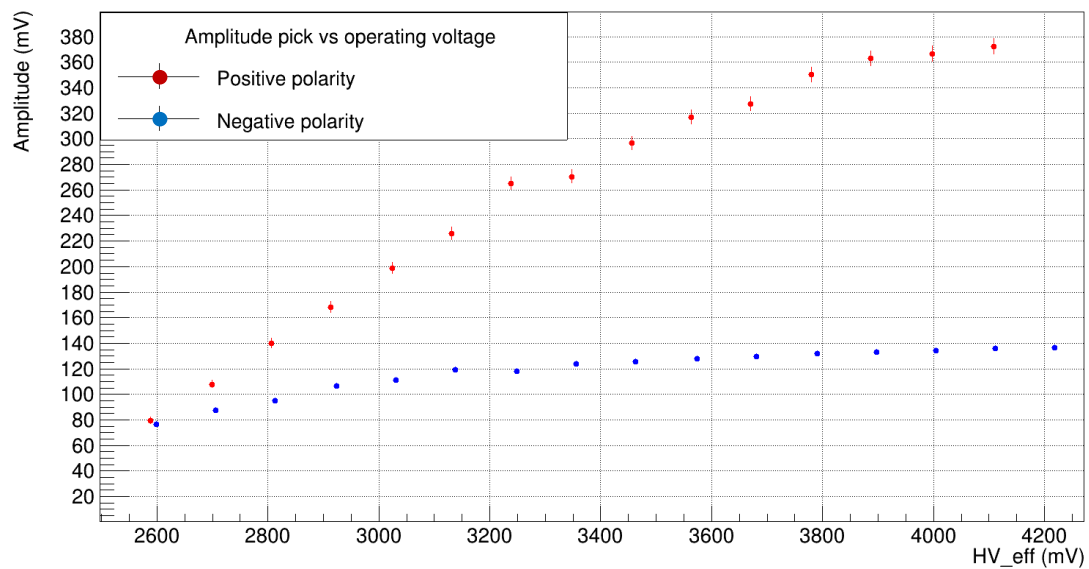
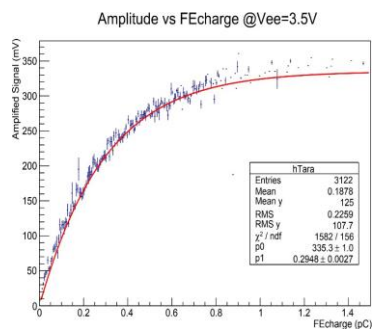

TIME DELAY

