

Exploring Exotic Spin-Dependent Interactions in Muons and Electrons Across Microscopic and Macroscopic Ranges

H. Yan



Institute of Nuclear Physics and Chemistry, CAEP



Outline



- Background
- Research progress using muons and electrons
- A Proposed Experimental Scheme Using a Polarized Muon Beam

PQ Mechanism: Proposed by Peccei and Quinn In 1977

A new global symmetry is introduced and spontaneously broken:

$$\mathcal{L} = -\frac{1}{4} F_{\mu\nu}^a F^{\mu\nu a} + i \bar{\psi} D_{\mu} \gamma^{\mu} \psi + \bar{\psi} [G \varphi \frac{1}{2} (1 + \gamma_5) + G^* \varphi^* \frac{1}{2} (1 - \gamma_5)] \psi - |\partial_{\mu} \varphi|^2 - \mu^2 |\varphi|^2 - h |\varphi|^4; \quad \mu^2 < 0.$$

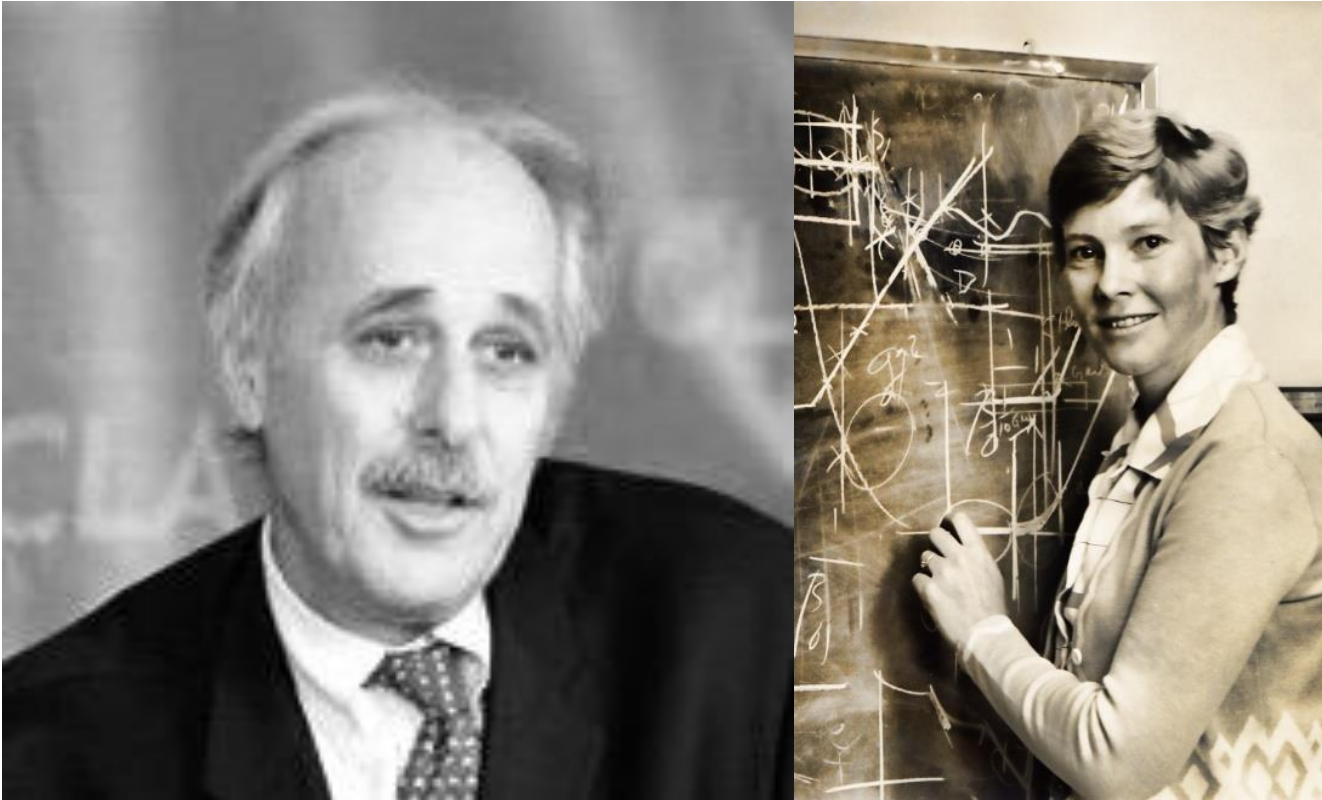

R.Peccei与H.Quinn

W&W: noticing axion generation simultaneously



), NUMBER 4

PHYSICAL REVIEW LETTERS

23 JANUARY 1978 NUMBER 5

PHYSICAL REVIEW LETTERS

30 JANUARY 1978

A New Light Boson?

Steven Weinberg

Lyman Laboratory of Physics, Harvard University, Cambridge, Massachusetts 02138
(Received 6 December 1977)

It is pointed out that a global $U(1)$ symmetry, that has been introduced in order to preserve the parity and time-reversal invariance of strong interactions despite the effects of instantons, would lead to a neutral pseudoscalar boson, the "axion," with mass roughly of order 100 keV to 1 MeV. Experimental implications are discussed.

Problem of Strong P and T Invariance in the Presence of Instantons

F. Wilczek^(a)

Columbia University, New York 10027, and The Institute for Advanced Studies, Princeton, New Jersey 08540^(b)
(Received 29 November 1977)

The requirement that P and T be approximately conserved in the color gauge theory of strong interactions without arbitrary adjustment of parameters is analyzed. Several possibilities are identified, including one which would give a remarkable new kind of very light, long-lived pseudoscalar boson.

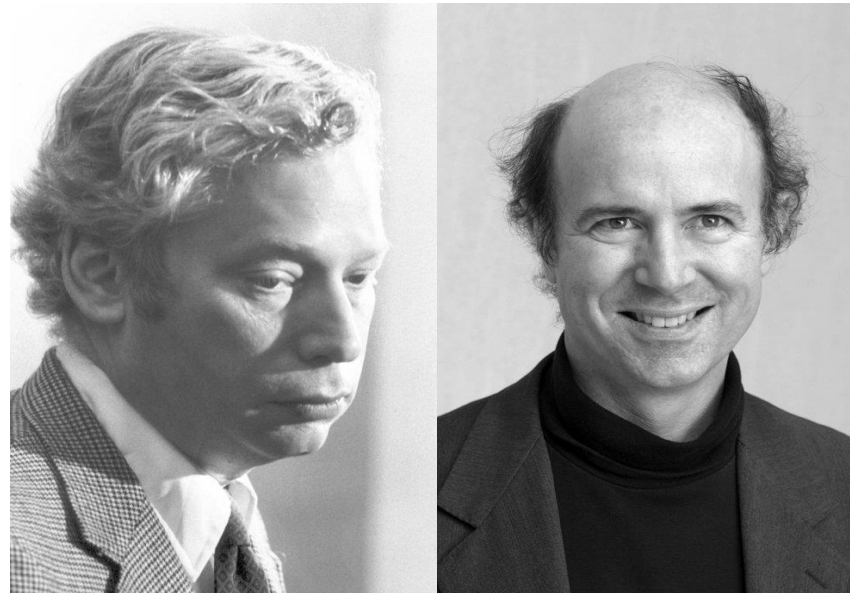

S.Weinberg与F.Wilczek

Axion: named by F. Wilczek

Frank Wilczek:

...我们认识到这个对称性意味着存在一种性质非常不一样的粒子——轴子（axion）（我用了一种洗衣粉的名字来命名这个粒子，因为它用轴矢流“清除”了一个问题）

“关于轴子物理已经有了大量的工作，也开过几次专门或部分讨论轴子的国际会议。经过多年大量的检验，它的核心思想发生了演化并且成熟了。另一方面，其他解决强P、T问题的方案的说服力都不能与之相比。

现在基础物理和宇宙学的一个重要目标是，要么证实轴子的存在，要么否定它。最近，世界上关于轴子的研究活动激增，表明这已经是一个被广泛接受的想法。”



F. Wilczek: More than Just the Namer of Axion

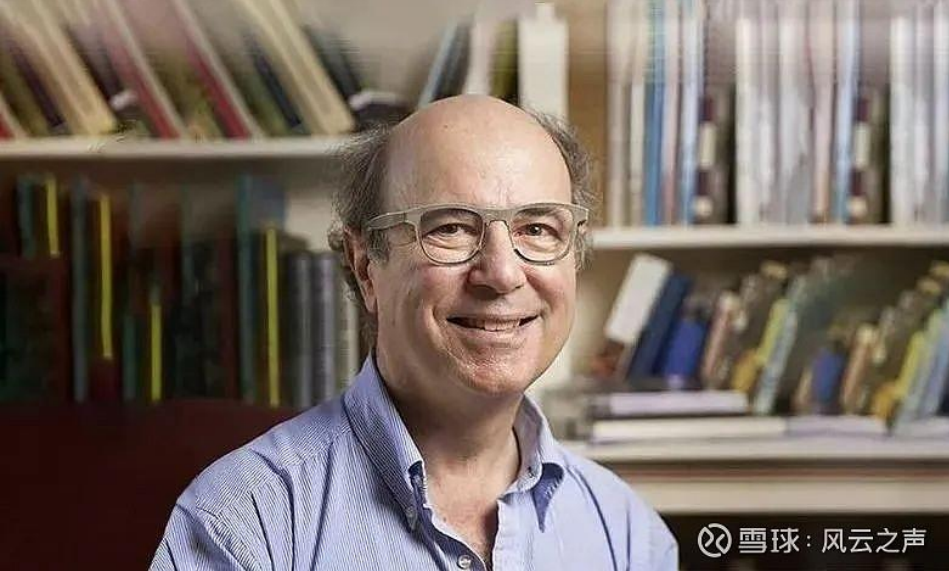

Accounting for a Wrinkle in Time

In most cases, physics follows the same rules whether things run forward or backward—but not quite always

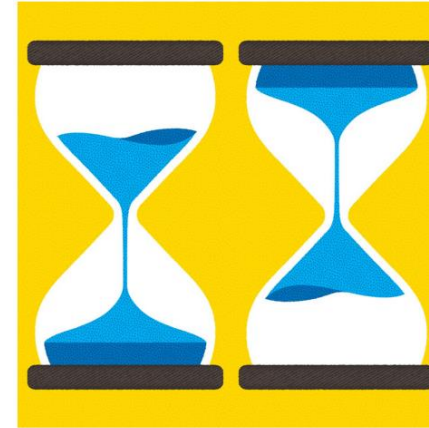

ILLUSTRATION: TOMASZ WALENTA

By Frank Wilczek
Nov. 17, 2022 at 3:27 pm ET

Frank Wilczek @FrankWilczek · 10h ...
If you started thinking "axion", you'd have got it in 2 at most. (Maybe 1 - I haven't checked if Wordle accepts "axion".) I didn't, and I paid the price ...
[@mjgoldman](#) [@KarenAndAndrew](#)



Axions are predicted to be hard to detect, but research physicists around the world are designing and building instruments that could be up to the job. If so, the ultimate explanation for exceptions to T would be different from Feynman's joke and more in line with one of Einstein's:

"Subtle is the Lord, but malicious He is not!"

Axions: mediating macroscopic interactions

PHYSICAL REVIEW D

VOLUME 30, NUMBER 1

1 JULY 1984

New macroscopic forces?

J. E. Moody* and Frank Wilczek

Institute for Theoretical Physics, University of California, Santa Barbara, California 93106

(Received 17 January 1984)

The forces mediated by spin-0 bosons are described, along with the existing experimental limits. The mass and couplings of the invisible axion are derived, followed by suggestions for experiments to detect axions via the macroscopic forces they mediate. In particular, novel tests of the T -violating axion monopole-dipole forces are proposed.

$$\mathcal{L}_\phi = \bar{\psi}(g_s + ig_p\gamma_5)\psi\phi \longrightarrow V_{SP}(r) = \frac{\hbar^2 g_S g_P}{8\pi m_e} \left(\frac{1}{\lambda r} + \frac{1}{r^2} \right) \exp(-r/\lambda) \vec{\sigma} \cdot \hat{r}$$

1. The most elegant and promising solution to the strong CP problem in QCD;
2. Very hard to detect, couple to the ordinary matter very weakly—candidate for cold dark matter;

$$m_A^2 = \frac{-v}{F^2} \left[\frac{m_u m_d m_s}{m_u m_d + m_d m_s + m_s m_u} \right] \quad H_{\text{int}} = a \frac{m_e}{F} \bar{e} i \gamma_5 e .$$

3. Axion and ALPs can mediate macroscopic interactions thus can be probed through the bosonic field they generate;
4. Spin dependent interactions can be propagated—polarized spins are needed.

Axion Like Particles: generalization



Spin 1 boson coupled Lagrangian: $\mathcal{L}_X = \bar{\psi}(g_V\gamma^\mu + g_A\gamma^\mu\gamma_5)\psi X_\mu$

$$V_{VA}(r) = \frac{\hbar g_V g_A}{2\pi} \frac{\exp(-r/\lambda)}{r} \vec{\sigma} \cdot \vec{v}$$
$$V_{AA}(r) = \frac{\hbar^2 g_A^2}{16\pi m c} \left(\frac{1}{\lambda r} + \frac{1}{r^2} \right) \exp(-r/\lambda) \vec{\sigma} \cdot (\vec{v} \times \hat{r})$$

- 1. Dobrescu et al: the propagator of the new interaction could be spin-1 particle;**
- 2. Fayet noticed that spontaneous breaking of supersymmetry theory could generate spin 1 particle with light mass and weak coupling.**

B. Dobrescu and I. Mocioiu, J. High Energy Phys. 11, 005(2006).
P. Fayet, Phys. Lett., 95B(2), 285, (1980).

Axions & ALPs:

The intersection of the most important problems in modern physics and astronomy



PUBLISHED BY INSTITUTE OF PHYSICS PUBLISHING FOR SISSA

RECEIVED: June 9, 2006
ACCEPTED: June 12, 2006
PUBLISHED: June 26, 2006

Axions in string theory

Peter Svrček

*Department of Physics and SLAC, Stanford University
Stanford CA 94305/94309 U.S.A.
E-mail: svrcek@stanford.edu*

Edward Witten

*Institute For Advanced Study
Princeton NJ 08540 U.S.A.
E-mail: witten@ias.edu*

ABSTRACT: In the context of string theory, axions appear to provide the most plausible solution of the strong CP problem. However, as has been known for a long time, in many string-based models, the axion coupling parameter F_a is several orders of magnitude higher than the standard cosmological bounds. We re-examine this problem in a variety of models, showing that F_a is close to the GUT scale or above in many models that have GUT-like phenomenology, as well as some that do not. On the other hand, in some models with Standard Model gauge fields supported on vanishing cycles, it is possible for F_a to be well below the GUT scale.

KEYWORDS: [Superstring Vacua](#), [QCD](#)

JHEP06(2006)051

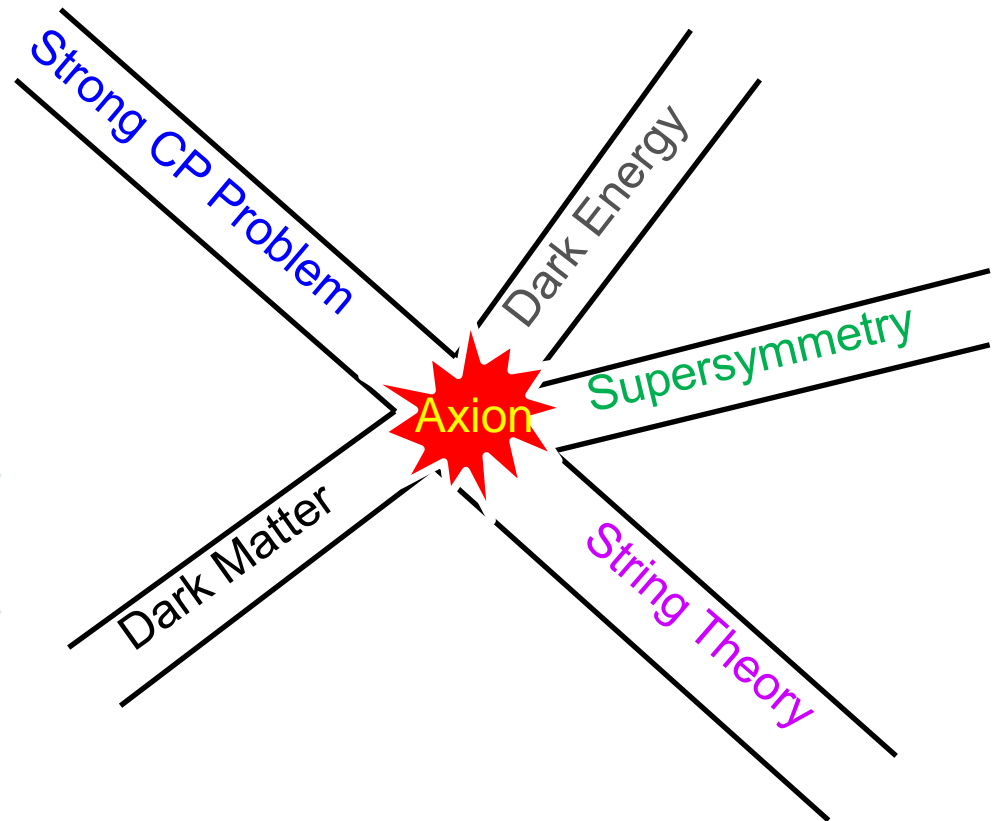

A detective board:



To detect, you have to interact:

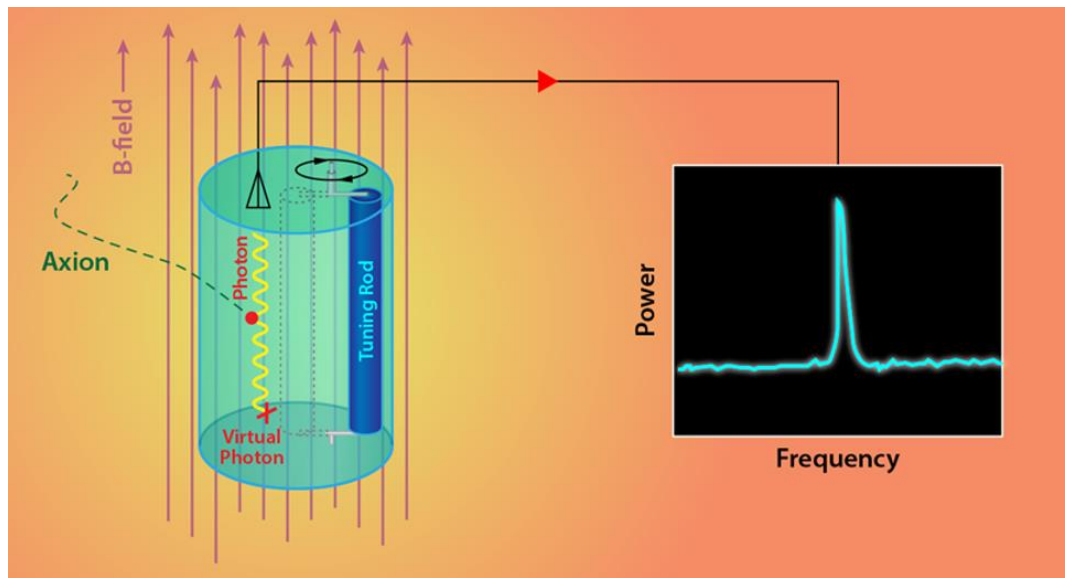
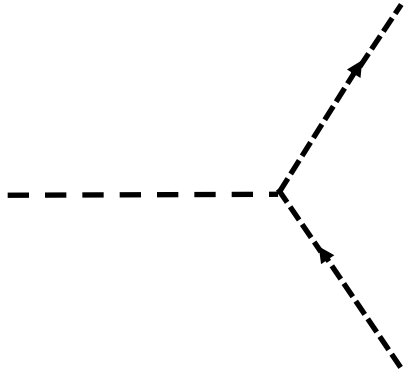
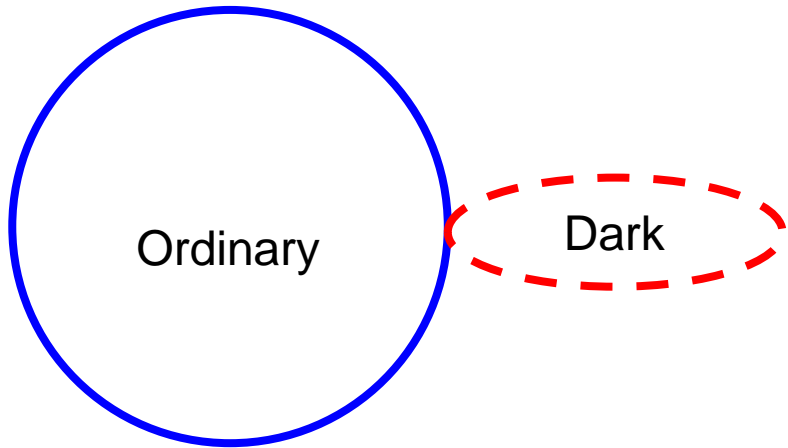

To detect, you have to interact:

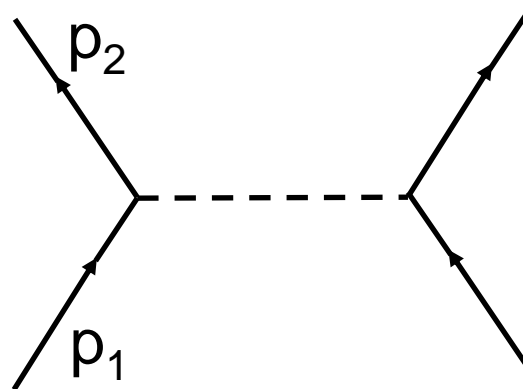
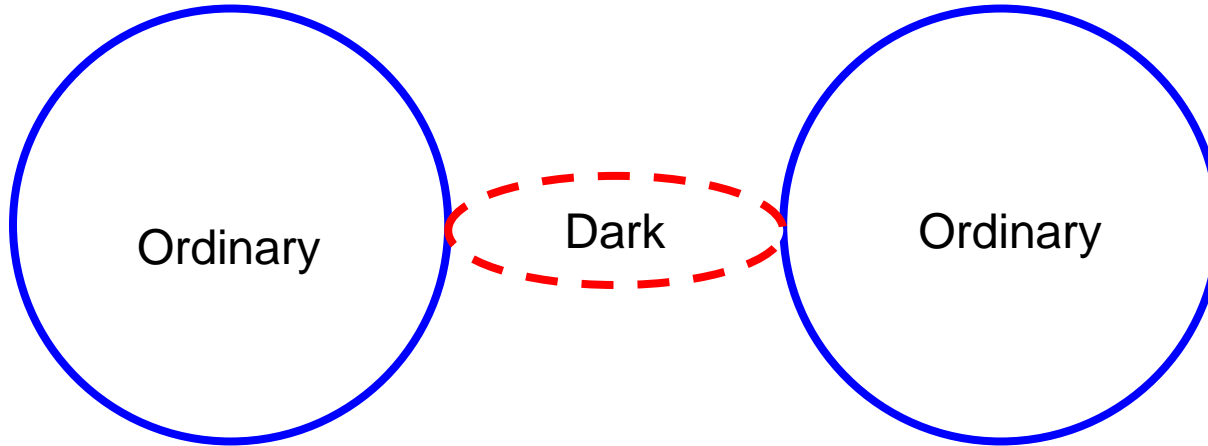

Three scalars to be measured:



$$\mathcal{L}_\phi = \bar{\psi}(g_s + ig_p\gamma_5)\psi\phi \longrightarrow V_{SP}(r) = \frac{\hbar^2 g_S g_P}{8\pi m_e} \left(\frac{1}{\lambda r} + \frac{1}{r^2} \right) \exp(-r/\lambda) \vec{\sigma} \cdot \hat{r}$$

$$\mathcal{L}_X = \bar{\psi}(g_V\gamma^\mu + g_A\gamma^\mu\gamma_5)\psi X_\mu \longrightarrow V_{VA}(r) = \frac{\hbar g_V g_A \exp(-r/\lambda)}{2\pi r} \vec{\sigma} \cdot \vec{v}$$
$$V_{AA}(r) = \frac{\hbar^2 g_A^2}{16\pi m c} \left(\frac{1}{\lambda r} + \frac{1}{r^2} \right) \exp(-r/\lambda) \vec{\sigma} \cdot (\vec{v} \times \hat{r})$$

1. $\sigma \cdot r$ pseudo-Scalar, breaks P and T

2. $\sigma \cdot v$ pseudo-Scalar, breaks P and C

3. $\sigma \cdot (v \times r)$ scalar

$$\mathcal{L}_I = \bar{\psi}(g_S + ig_P\gamma_5)\psi\phi$$

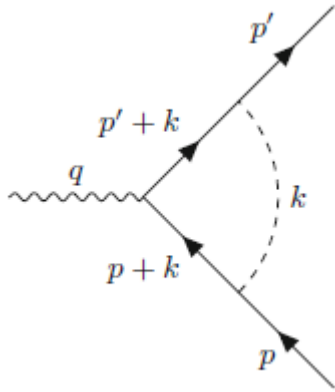

$$\begin{aligned} & \bar{u}(p')\Lambda^\mu u(p) \\ &= \bar{u}(p') \left[\gamma^\mu F_1(q^2) + i\frac{\sigma^{\mu\nu}q_\nu}{2m} F_2(q^2) \right. \\ & \quad \left. + \gamma^5 \frac{\sigma^{\mu\nu}q_\nu}{2m} F_3(q^2) + \gamma^5 (q^2\gamma^\mu - 2m\gamma^5 q^\mu) F_4(q^2) \right] u(p) \end{aligned}$$

$eF_2(0)/2m$: anomalous magnetic moment;

$-eF_3(0)/2m$: EDM

The one loop level calculation:



$$\mathcal{L}_I = \bar{\psi}(g_S + ig_P\gamma_5)\psi\phi \quad x = m_\phi/m$$

$$F_2(0) = -\frac{g_S g_S}{8\pi^2} SS(x) \quad F_2(0) = -\frac{g_P g_P}{8\pi^2} PP(x) \quad F_3(0) = \frac{g_S g_P}{4\pi^2} SP(x)$$

$$SS(x) = \frac{3}{2} - x^2 + x^2(x^2 - 3) \ln x + x(x^2 - 1)\sqrt{x^2 - 4} \left[\tanh^{-1} \left(\frac{x}{\sqrt{x^2 - 4}} \right) - \tanh^{-1} \left(\frac{x^2 - 2}{x\sqrt{x^2 - 4}} \right) \right]$$

$$PP(x) = \frac{1}{2} + x^2 - x^2(x^2 - 1) \ln x + \frac{x^3(3 - x^2)}{\sqrt{x^2 - 4}} \left[\tanh^{-1} \left(\frac{x}{\sqrt{x^2 - 4}} \right) - \tanh^{-1} \left(\frac{x^2 - 2}{x\sqrt{x^2 - 4}} \right) \right]$$

$$SP(x) = 1 - x^2 \ln x - \frac{x(x^2 - 2)}{\sqrt{x^2 - 4}} \left[\tanh^{-1} \left(\frac{x}{\sqrt{x^2 - 4}} \right) - \tanh^{-1} \left(\frac{x^2 - 2}{x\sqrt{x^2 - 4}} \right) \right]$$

The Anomalous Magnetic Moment of the Muon in 2021

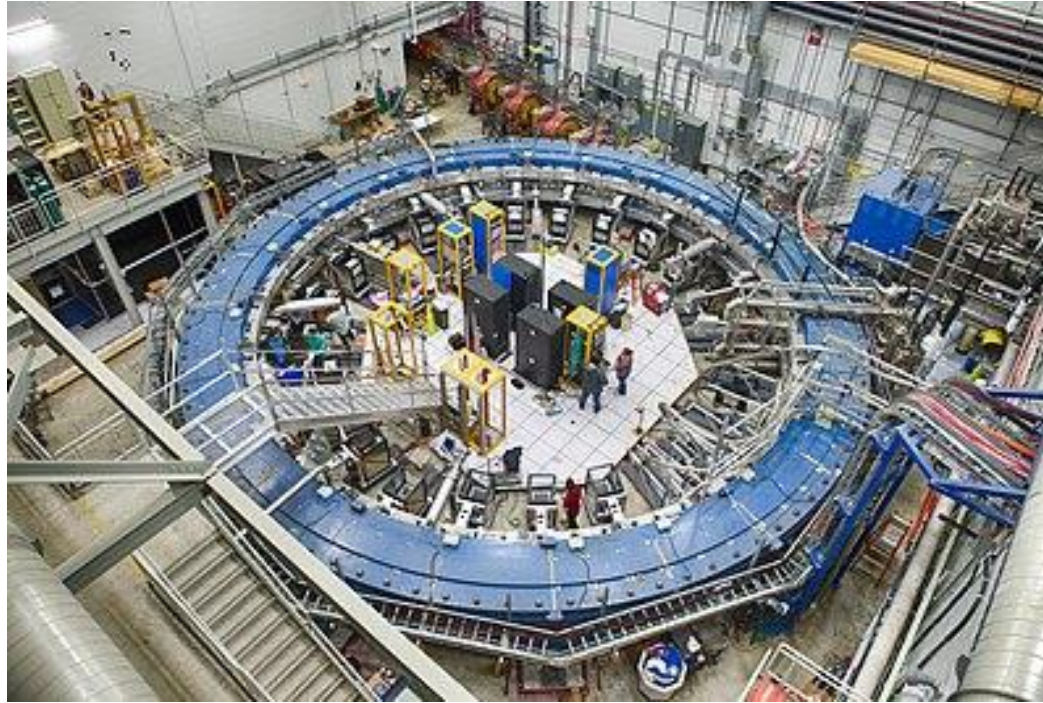

- The experimental value of the muon's anomalous magnetic moment from Fermilab in the United States differs from the theoretical result derived from the Standard Model by 4.2σ
- Previously, the measurement results from Brookhaven National Laboratory (BNL) in the United States in 2006 showed a difference of 3.7σ between the two.

$$a_{\mu}^{exp} - a_{\mu}^{SM} = 2.74 \pm 0.73 \times 10^{-9}$$

$$|g_S^{\mu} g_S^{\mu}| = 1.44 \pm 0.38 \times 10^{-7}$$

$$|g_P^{\mu} g_P^{\mu}| = 4.32 \pm 1.16 \times 10^{-7}$$

$$|d_{\mu}| < 1.8 \times 10^{-19} e.cm, 95\% C.L.$$

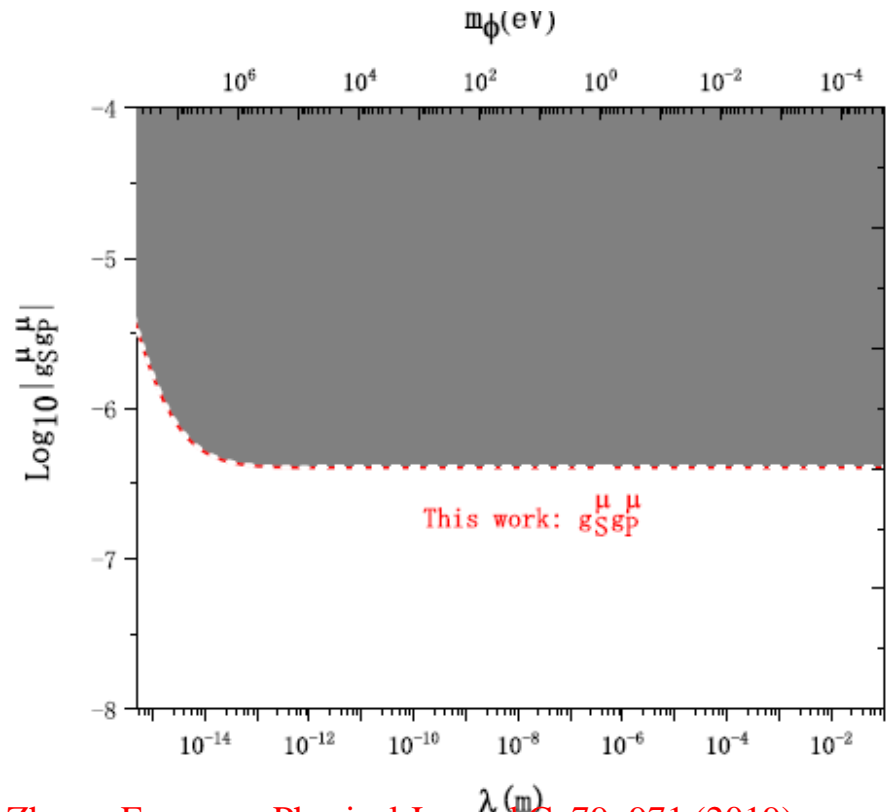

Applications to the electron :

$$|a_e^{exp} - a_e^{SM}| < 2.66 \times 10^{-12}, 95\%C.L.$$

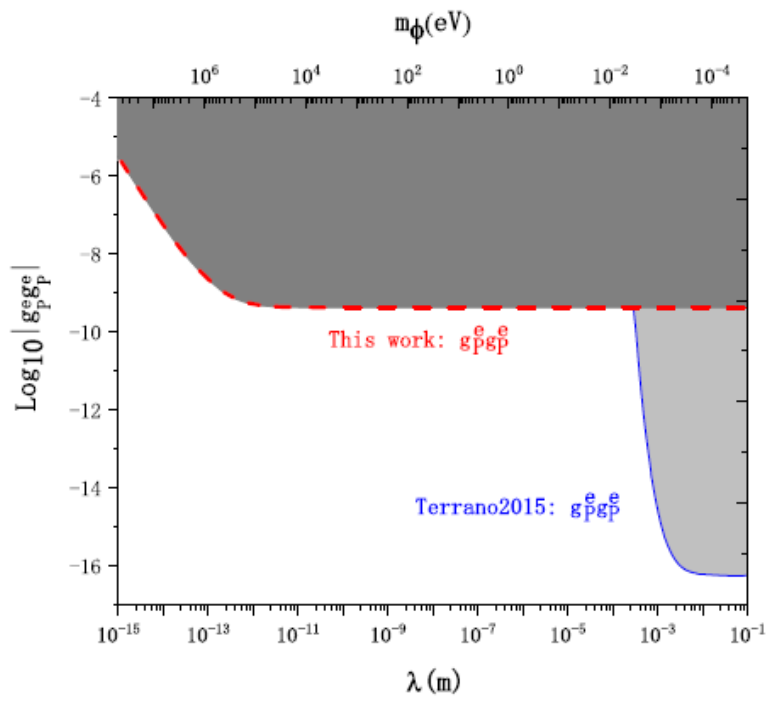
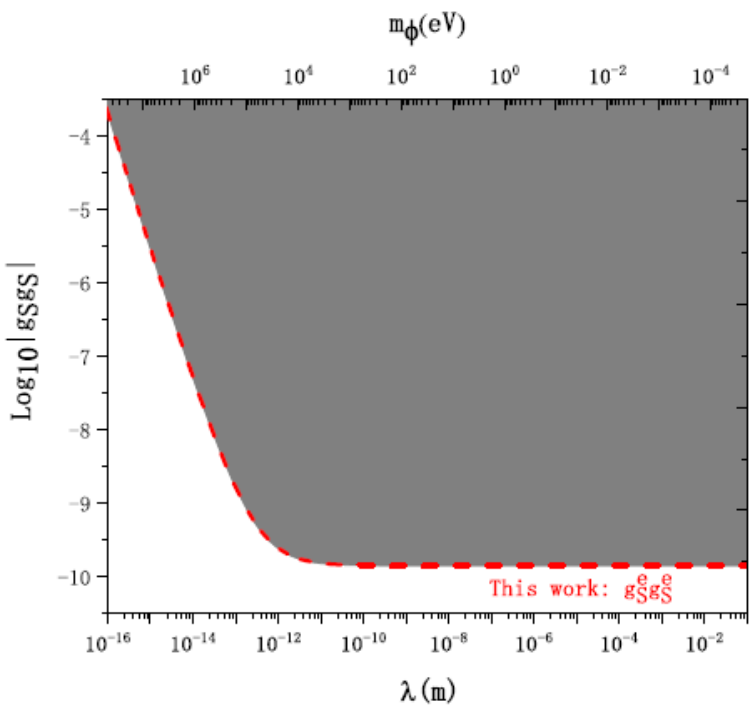

SERF Magnetometers :

based on polarized alkaline metal and have ultra high sensitivity

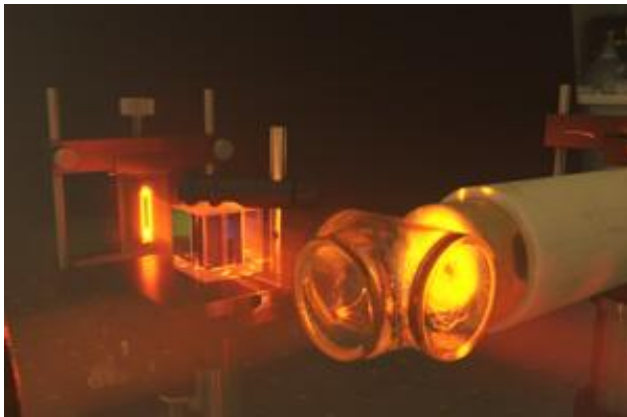
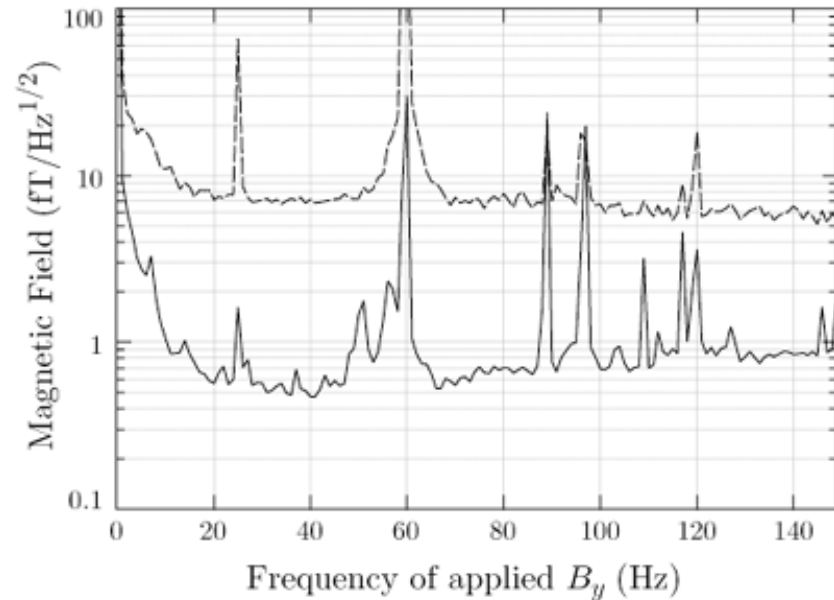
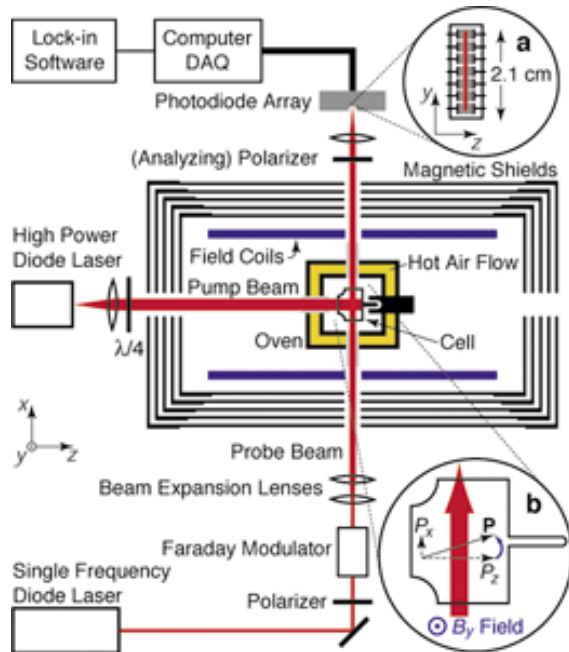

I. K. Kominis, T. W. Kornack, J. C. Allred & M. V. Romalis, "[A subfemtotesla multichannel atomic magnetometer.](#)" *Nature* **422**, 596 (2003).

The proposed experiment scheme:

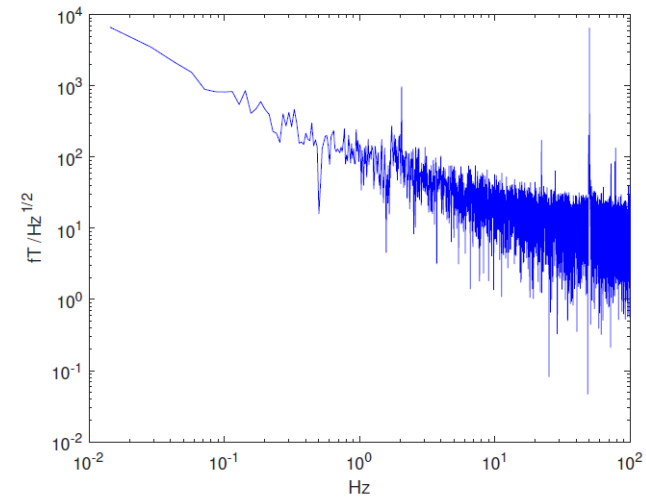
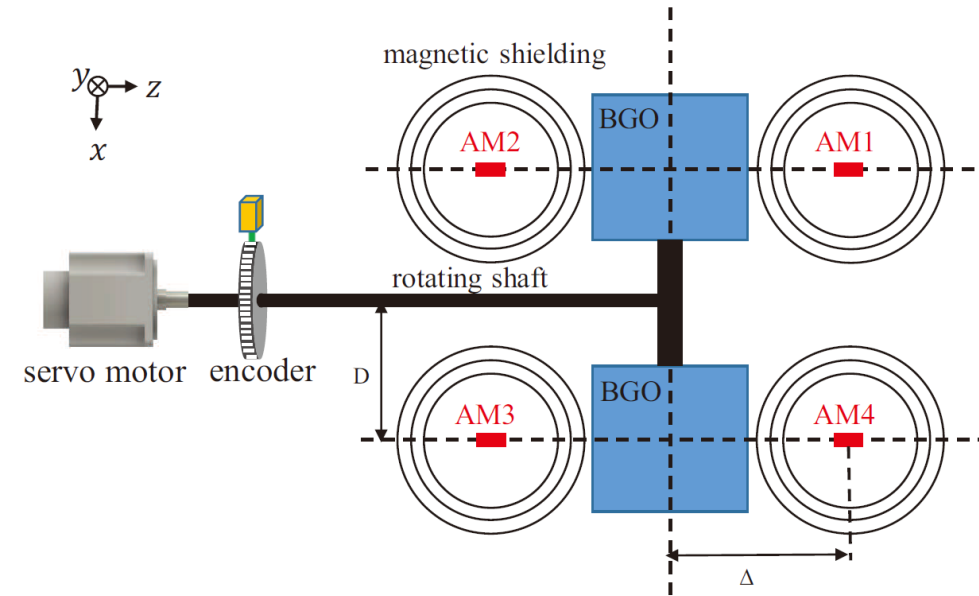

The typical noise power density of a Rb magnetometer

High speed rotating mass sources + magnetometer array

1. Modulation frequency ~20Hz, 40 times noise reduction;

2. Magnetometer array, increases statistics and cancels common-mode noise

$$\begin{aligned}
 B'_{Pz} &= \frac{1}{4}(B_{1z} - B_{2z} + B_{3z} - B_{4z}) \\
 &= B'_{Pz} + \sqrt{B_{bg}^2 + B_{bg}^2 + B_{bg}^2 + B_{bg}^2} \\
 &= B'_{Pz} + \frac{1}{2}B_{bg}
 \end{aligned}$$

$$V_{SP}(r) = \frac{\hbar^2 g_{SGP}}{8\pi m_e} \left(\frac{1}{\lambda r} + \frac{1}{r^2} \right) \exp(-r/\lambda) \vec{\sigma} \cdot \hat{r}$$

$$\begin{aligned}
 B_{1z} &= B'_{SPz} + B_{com} + B_{bg} \\
 B_{2z} &= -B'_{SPz} + B_{com} + B_{bg} \\
 B_{3z} &= -B'_{SPz} + B_{com} + B_{bg} \\
 B_{4z} &= B'_{SPz} + B_{com} + B_{bg}
 \end{aligned}$$

Data processing method:



$$\vec{B}'_{VA}(\vec{r}) = \frac{g_V g_A}{\pi \gamma_e} \int d^3 \vec{r}' \frac{\exp(-|\vec{r} - \vec{r}'|/\lambda)}{|\vec{r} - \vec{r}'|} \vec{v}$$

$$\vec{B}'_{AA}(\vec{r}) = \frac{\hbar g_A^2}{8\pi m_e c \gamma_e} \int d^3 \vec{r}' \left(\frac{1}{\lambda |\vec{r} - \vec{r}'|} + \frac{1}{|\vec{r} - \vec{r}'|^2} \right) \times \exp(-|\vec{r} - \vec{r}'|/\lambda) (\vec{v} \times \frac{\vec{r} - \vec{r}'}{|\vec{r} - \vec{r}'|})$$

$$g_V g_A = g_A^2 = 1$$

$$B'(t) = c_0 + \sum_{n=1}^{\infty} c_n \cos(n\omega_0 t + \phi)$$

$$c_n = \frac{2}{NT} \int_0^{NT} \cos(n\omega_0 t + \phi) B'(t) dt$$

$$B_{\text{exp}}(t) = \alpha c_0 + \alpha \sum_{n=1}^{\infty} c_n \cos(n\omega_0 t + \phi) + n(t)$$

$\alpha = g_V g_A$ for the VA interaction

$\alpha = g_A^2$ for the AA interaction

$$\alpha|_n = \frac{2 \int_0^{NT} \cos(n\omega_0 t + \phi) B_{\text{exp}}(t) dt}{c_n NT}$$

$$\delta \bar{\alpha}|_{\text{noise}} \sim \sqrt{S_N(nf_0)} \sqrt{\frac{2}{NT}} \frac{1}{\sqrt{\sum_{n=1}^4 c_n^2}}$$

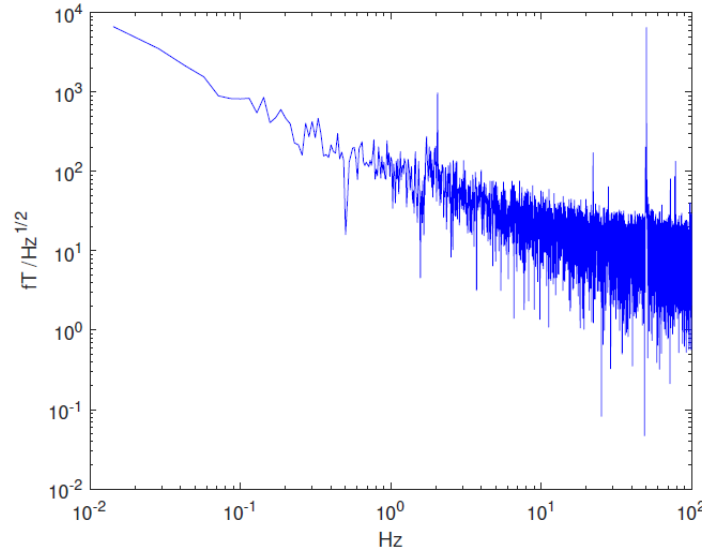
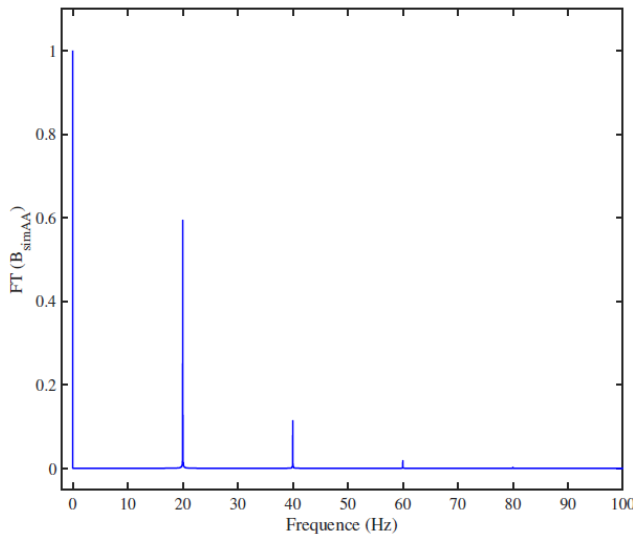

$$\bar{\alpha} = \frac{\sum_{n=1}^4 c_n^2 \alpha|_n}{\sum_{n=1}^4 c_n^2}$$

30 days ~ 10 aT (10⁻¹⁷T) precision

Phys. Rev. D **105**, 055020 (2022)

The experiment setup:

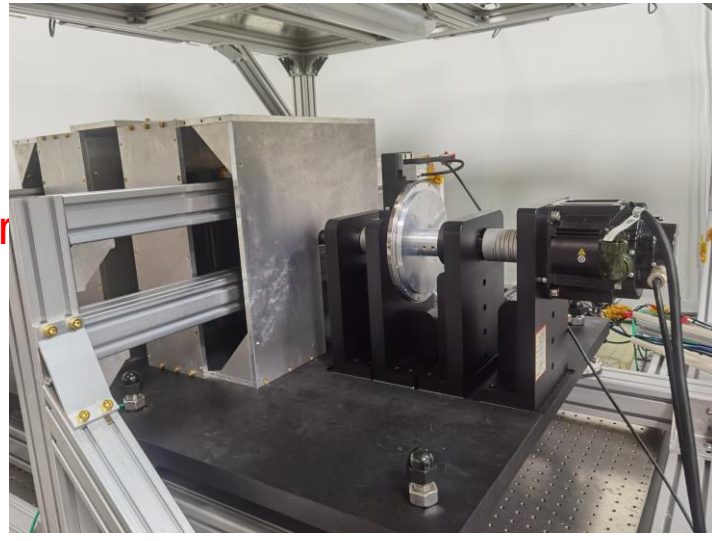
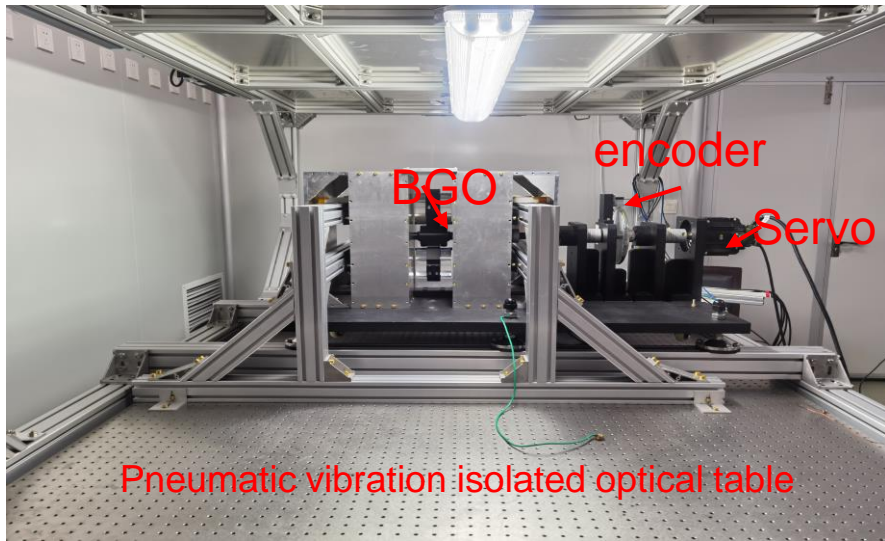
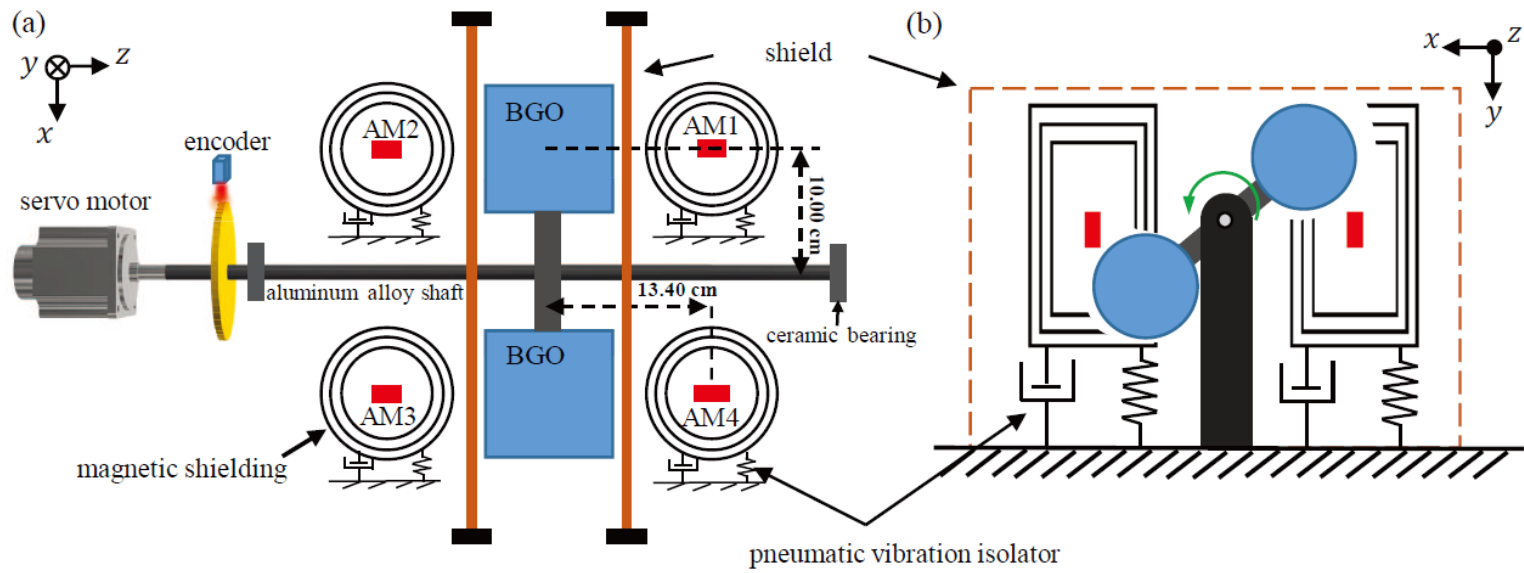

Main results:

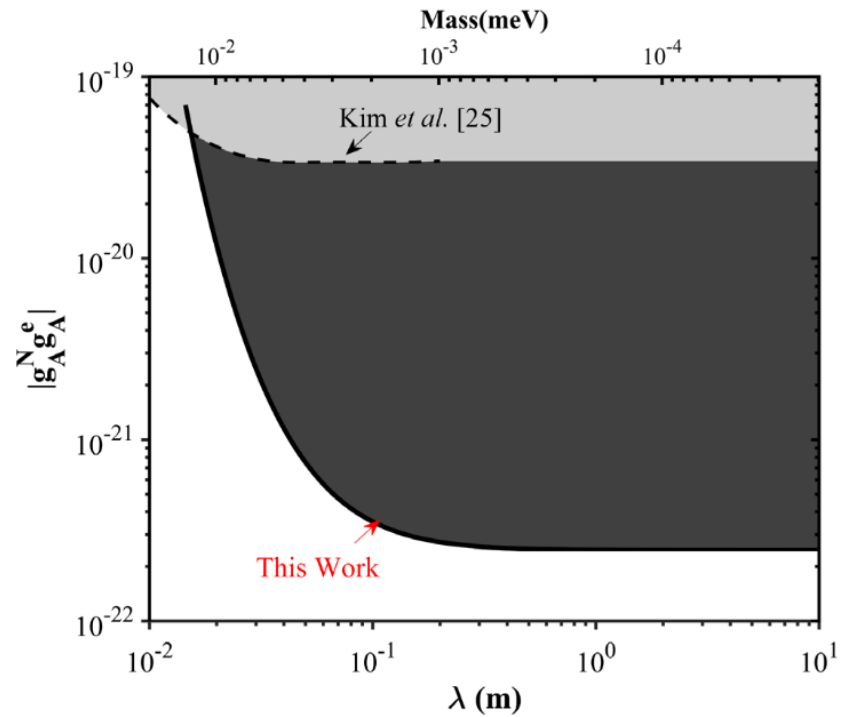
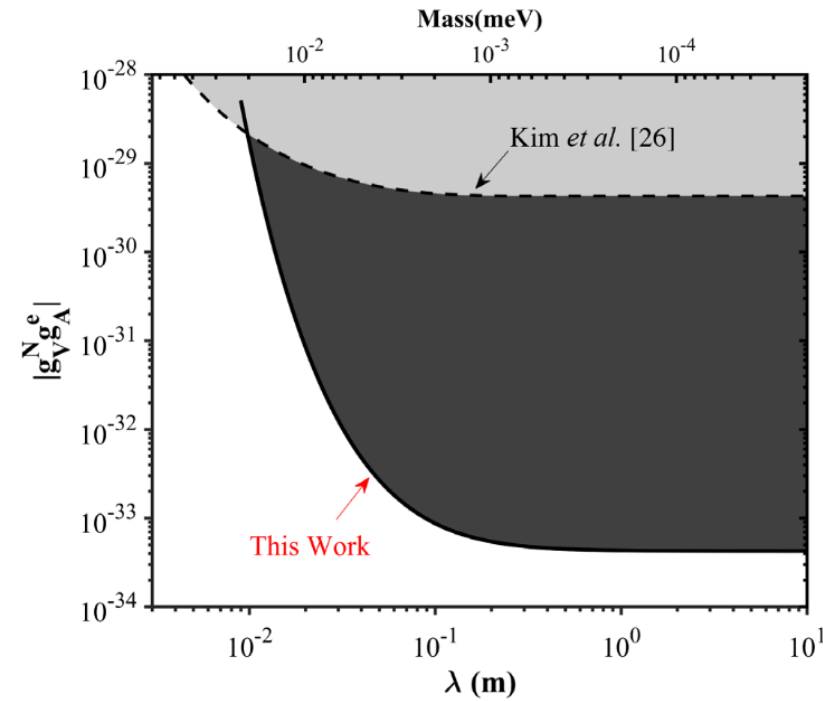

$$g_V^N g_A^e = 0.07 \pm 2.06(\text{stat}) \pm 0.07(\text{syst}) \times 10^{-34},$$

$$g_A^N g_A^e = -0.06 \pm 2.36(\text{stat}) \pm 0.08(\text{syst}) \times 10^{-22}.$$

Probing VA-Type Interactions Using Neutron Spin Rotation in Liquid Helium

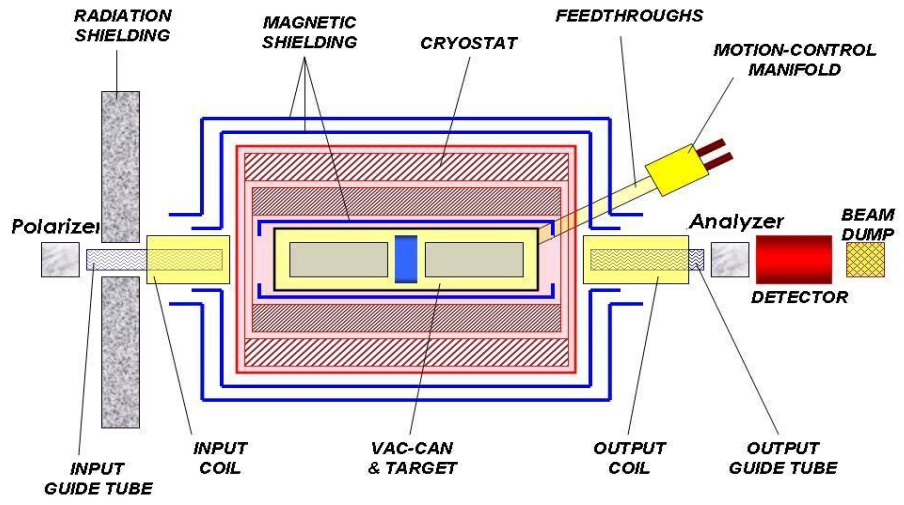

$$\frac{dj}{dL} < 9.2 \cdot 10^{-7} \text{ rad} / m$$

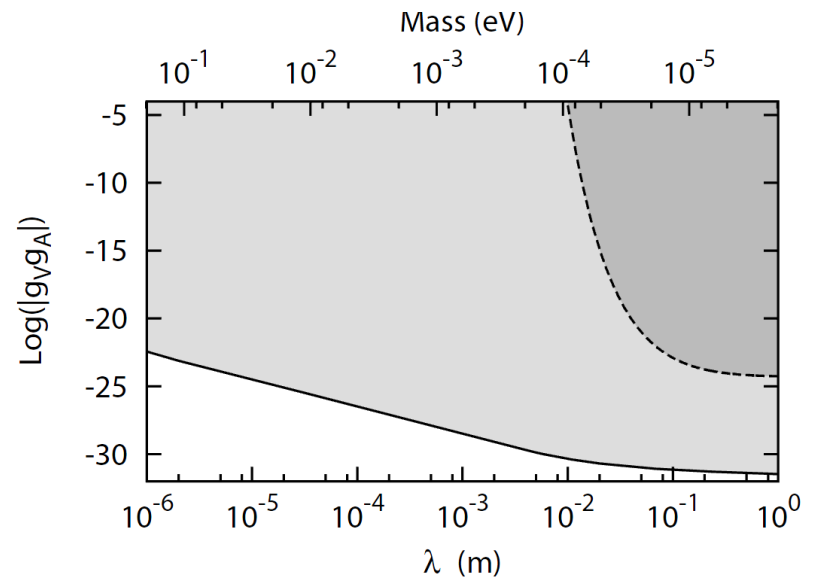

The Rough Concept of a Proposed Experimental Scheme for Muons

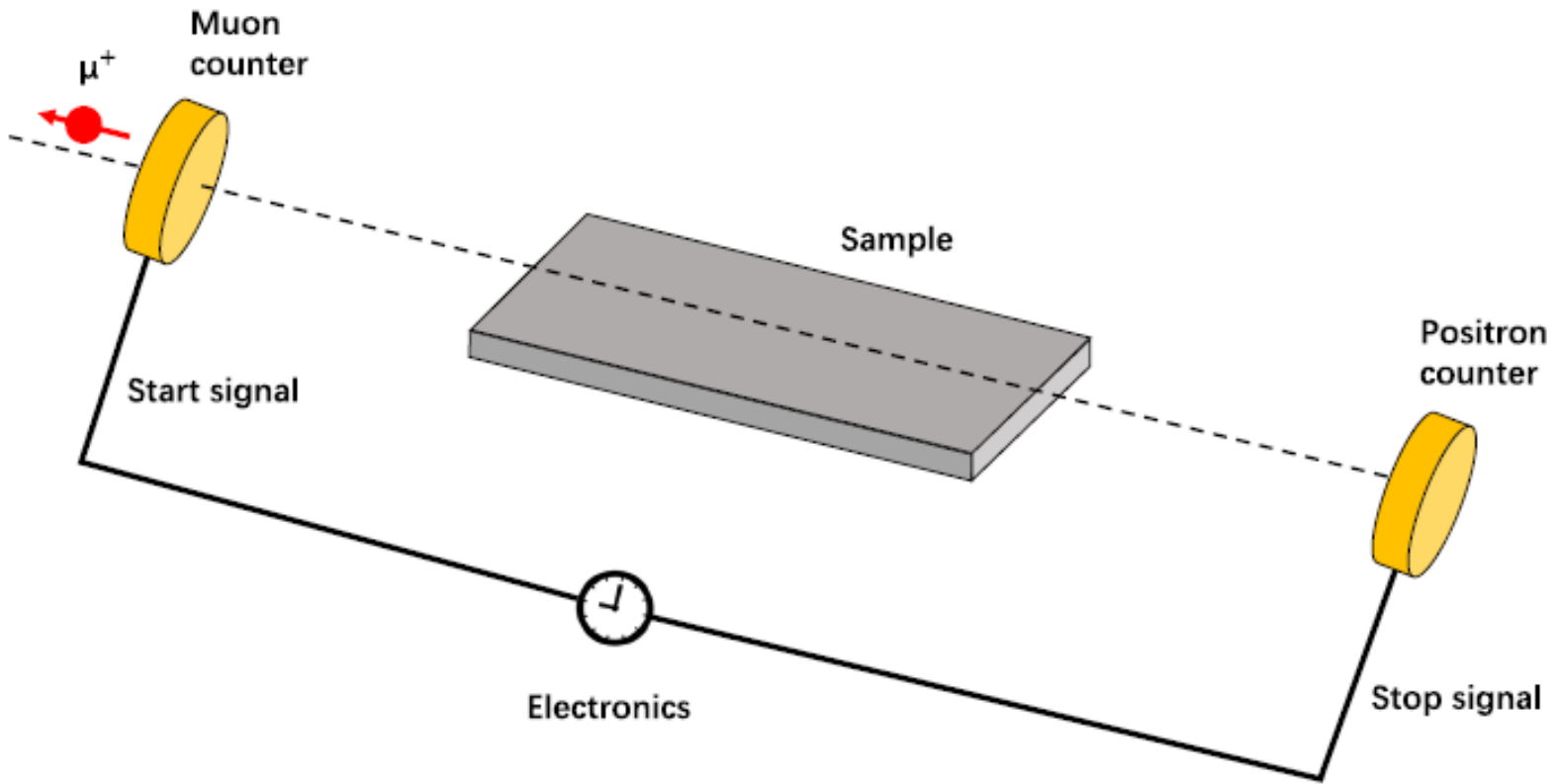

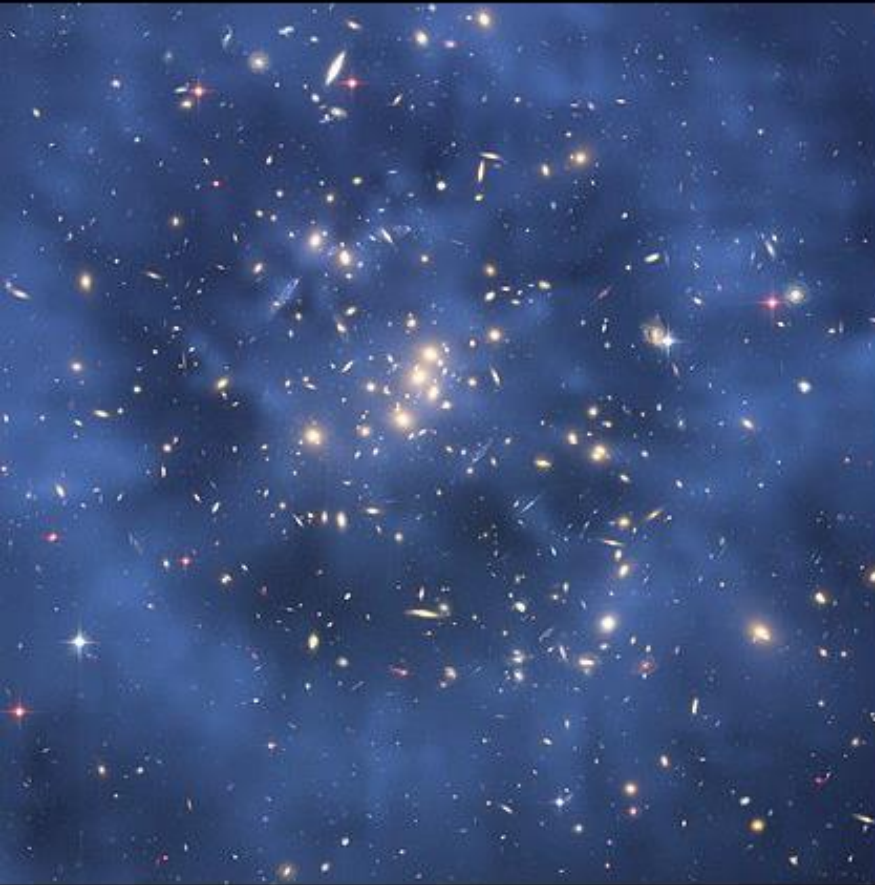

“ All mass is
interaction.”

~ *Richard Feynman*

Conclusion & Discussion:



“ All mass is
interaction. ”

~ *Richard Feynman*

QuotesCosmos

Many of these interactions could potentially be spin-dependent.

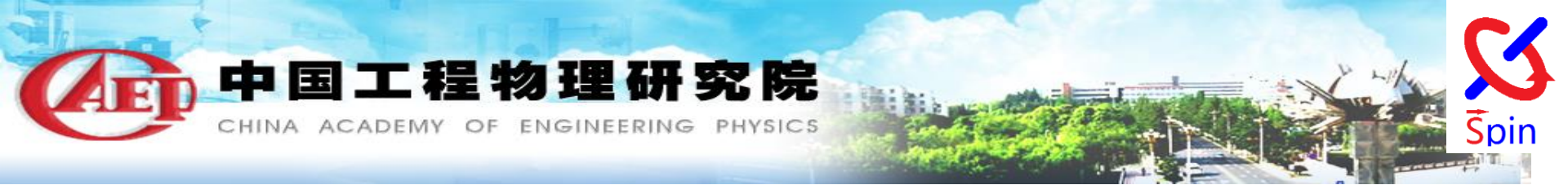

请批评指正！

谢谢

