

Linear Colliders

Lecture 4

Frank Tecker – CERN

- Damping rings
- NC/SC driven differences
- CLIC two beam scheme
- Drive Beam generation
- CLIC test facility CTF3

- SC allows long pulse, NC needs short pulse with smaller bunch charge

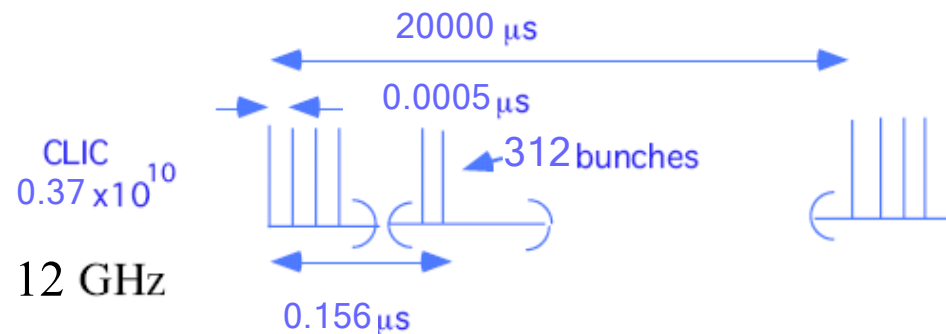
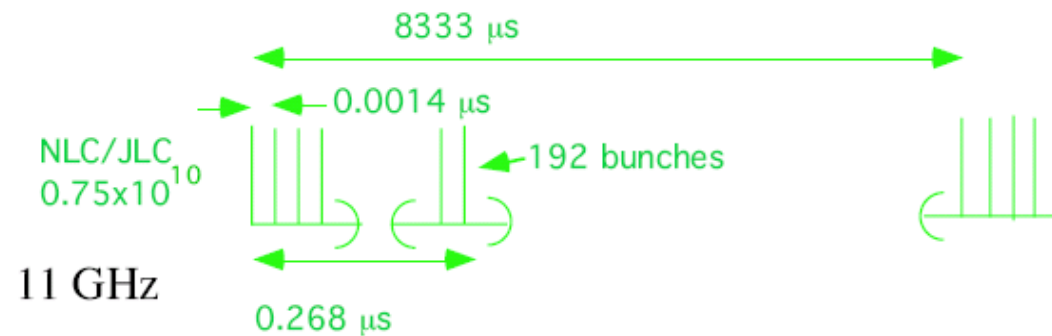
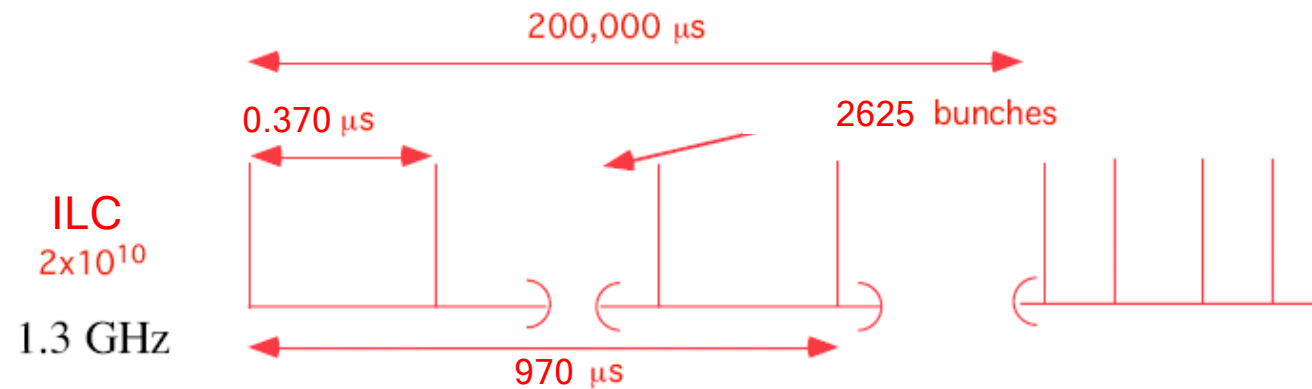

The different RF technologies used by ILC, NLC/JLC and CLIC require different packaging for the beam power

$C=17,000$ m

- Long pulse:
 $950\mu\text{s} * c = 285$ km!!
- Compress bunch train into 17 km (or less) “ring”
- **kick individual bunches**
- Min. circumference by ejection/injection kicker speed (≈ 20 ns)
- “Dog bone” ring with ≈ 400 m of 1.67 T wigglers
- 3.2 km circular rings in the baseline ILC design
- Very demanding kicker rise + fall time < 6 ns

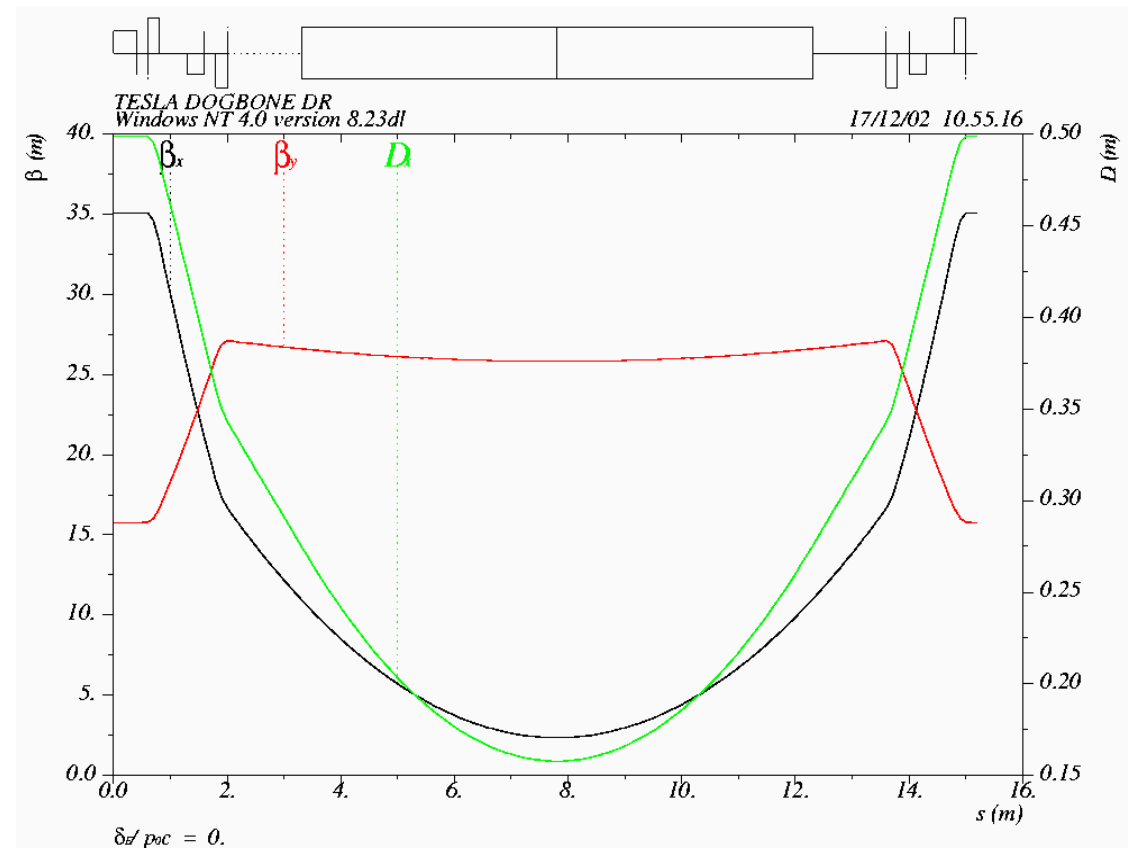
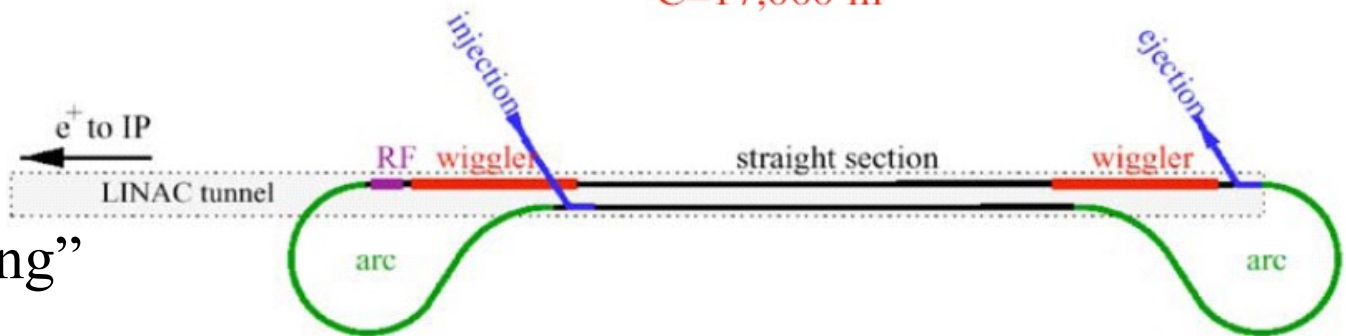

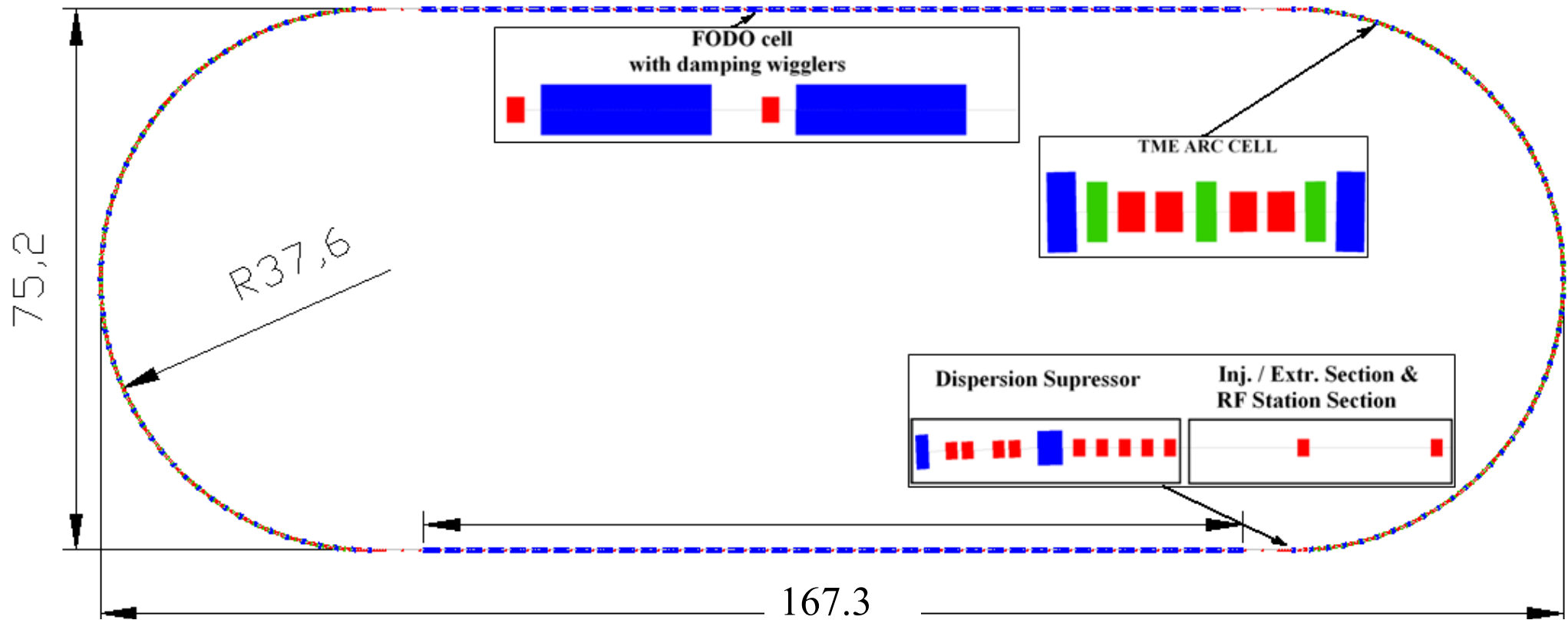

- Total length 421m (much smaller than ILC), beam pulse only 47m
- Racetrack shape with
 - 96 TME arc cells (4 half cells for dispersion suppression)
 - 26 Damping wiggler FODO cells in the long straight sections

• Normal Conducting

- High gradient \Rightarrow short linac 😊
- High rep. rate \Rightarrow ground motion suppression 😊
- Small structures \Rightarrow strong wakefields 😞
- Generation of high peak RF power 😞
- Small bunch distance 😞

• Superconducting

- long pulse \Rightarrow low peak power 😊
- large structure dimensions \Rightarrow low WF 😊
- very long pulse train \Rightarrow feedback within train 😊
- SC structures \Rightarrow high efficiency 😊
- Gradient limited <40 MV/m \Rightarrow longer linac 😞
(SC material limit ~ 55 MV/m)
- low rep. rate \Rightarrow bad GM suppression
(ϵ_y dilution) 😞
- Large number of e^+ per pulse 😞
- very large DR 😞

- **Very high gradients** (>100 MV/m) possible with NC accelerating structures at high RF frequencies (30 GHz \rightarrow 12 GHz)
- Extract required high RF power from an **intense** e- “**drive beam**”
- Generate **efficiently** long pulse and compress it (in power + frequency)

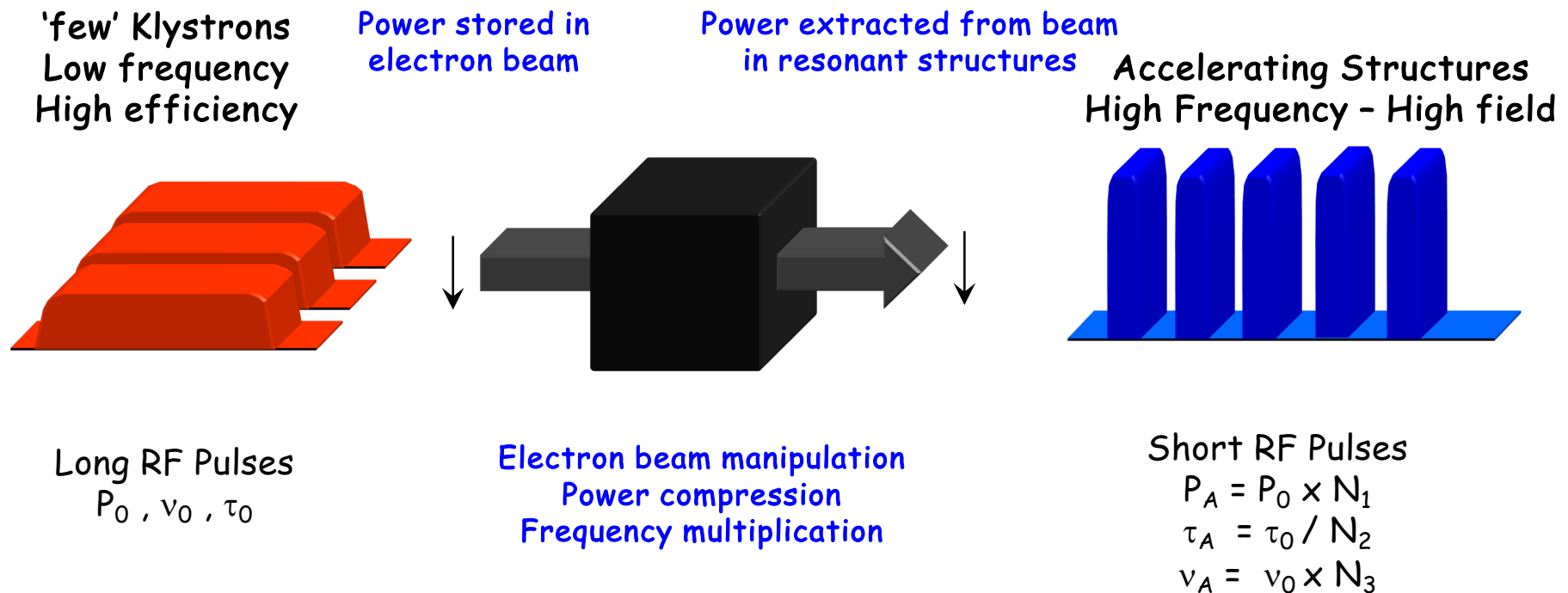

- High charge **Drive Beam** (low energy)
- Low charge **Main Beam** (high collision energy)
- => Simple tunnel, no active elements
- => Modular, easy energy upgrade in stages

CLIC TUNNEL
CROSS-SECTION

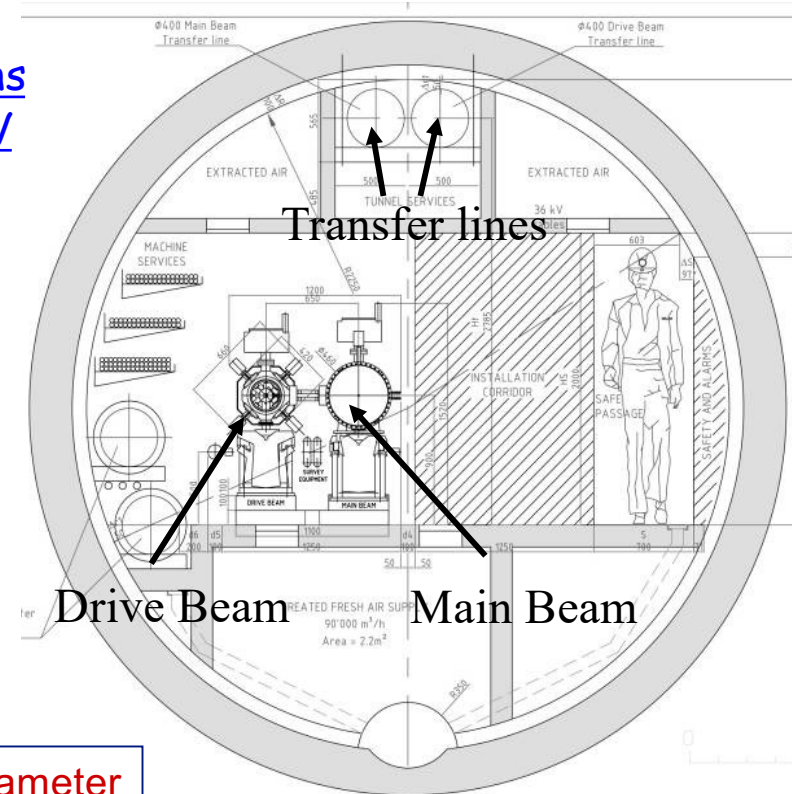

Drive beam - 101 A, 240 ns
from 2.4 GeV to 240 MeV

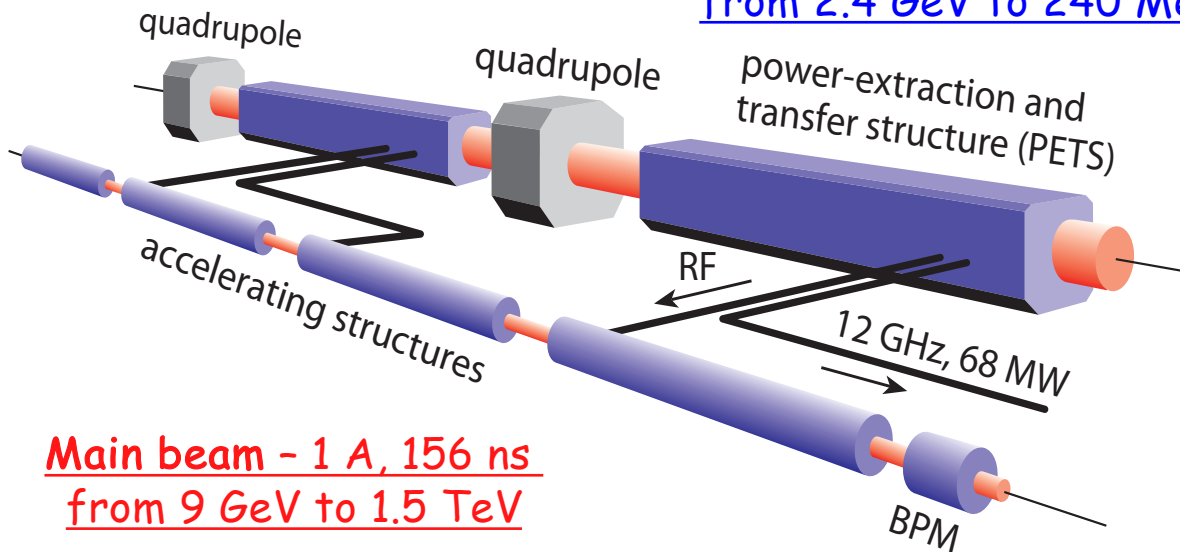

Main beam - 1 A, 156 ns
from 9 GeV to 1.5 TeV

5.6 m diameter

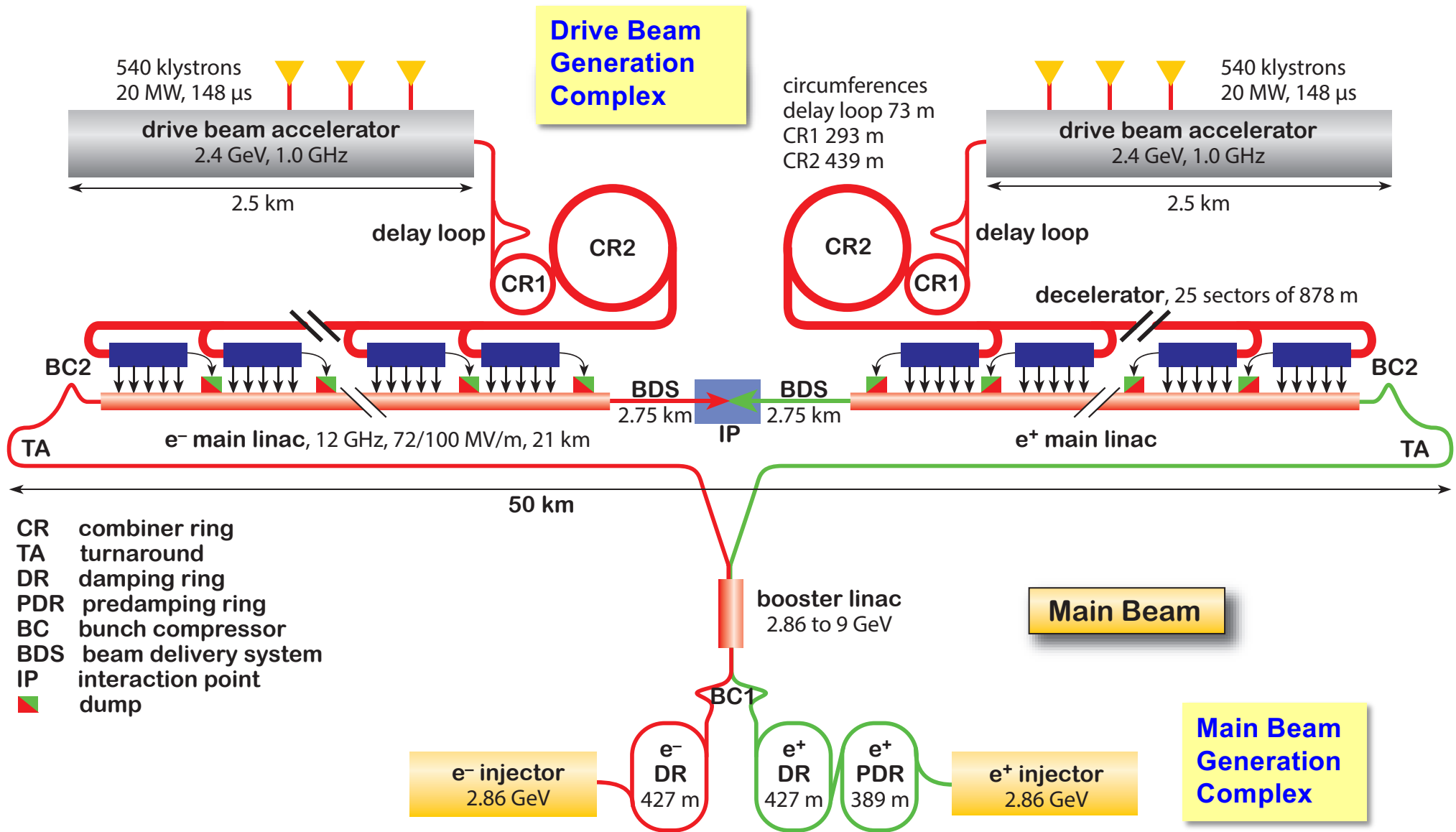

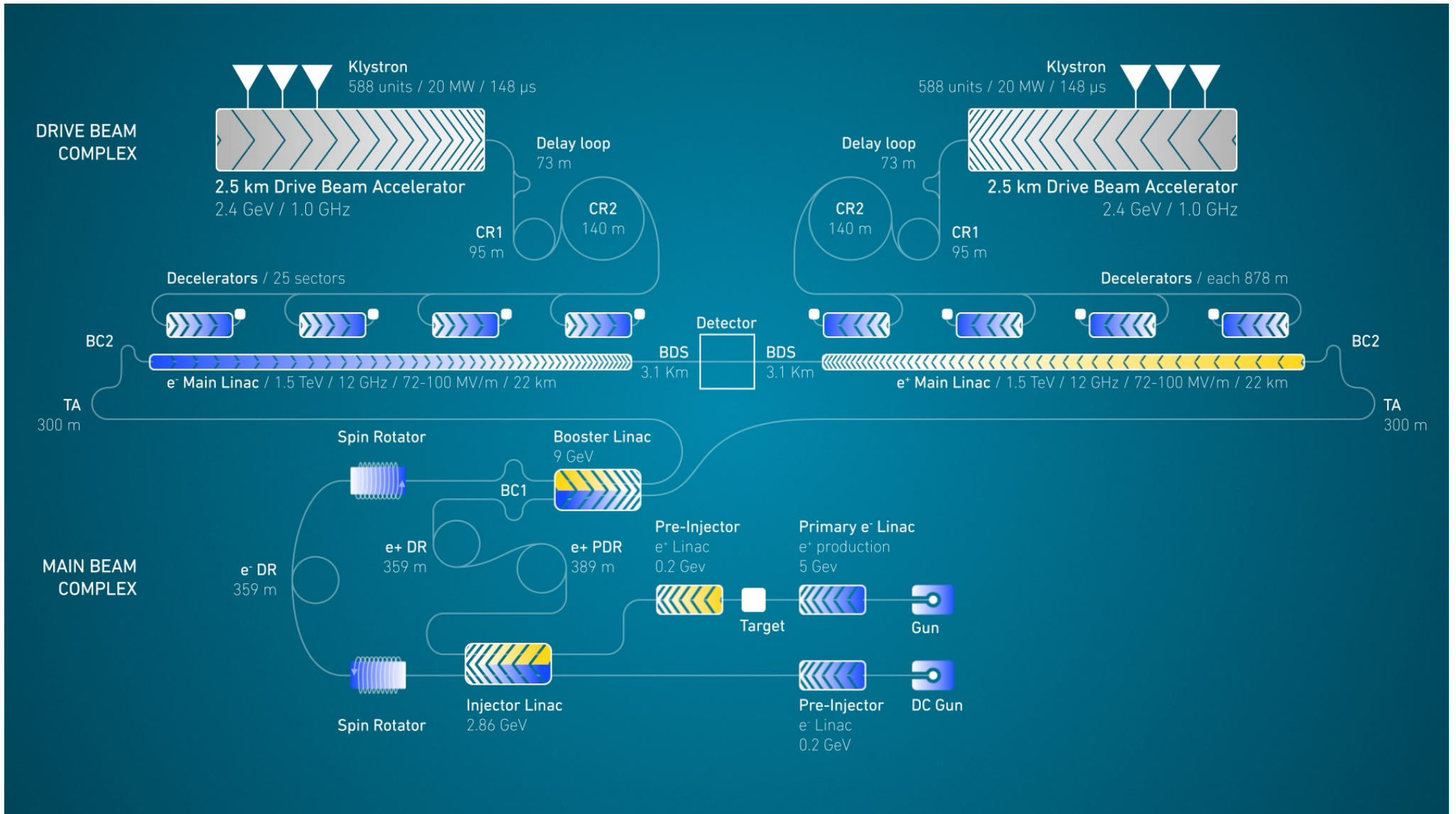

Counter propagation from central complex

Instead of using a single drive beam pulse for the whole main linac, several ($N_S = 25$) short drive beam pulses are used

Each one feed a ~ 880 m long sector of two-beam acceleration (TBA)

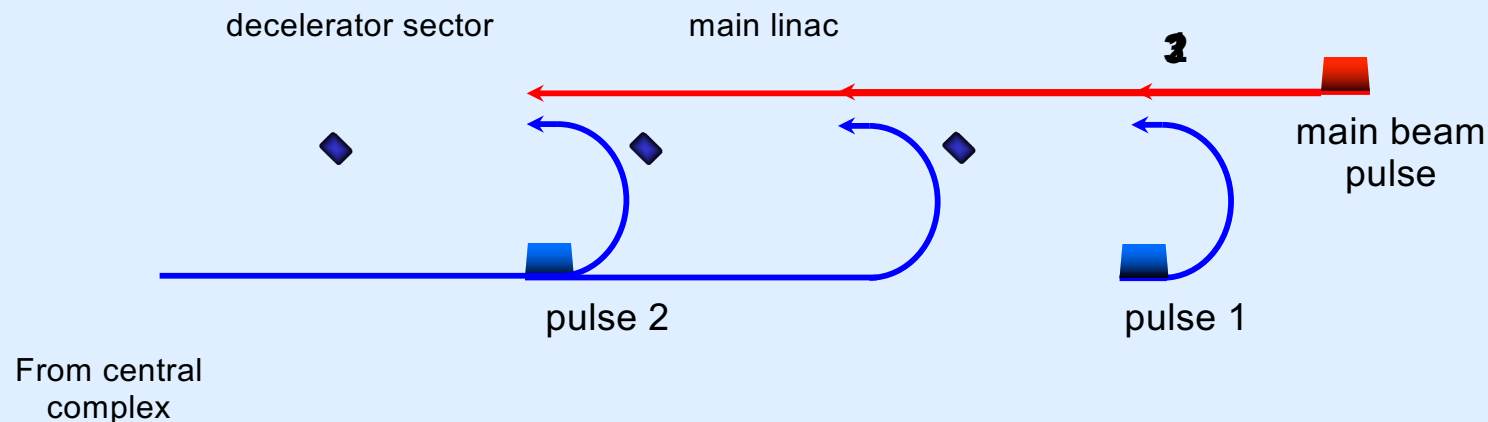

Counter flow distribution allows to power different sectors of the main linac with different time bins of a single long electron drive beam pulse

The distance between the pulses is $2 L_s = 2 L_{\text{main}}/N_S$ (L_{main} = single side linac length)

The initial drive beam pulse length t_{DB} is given by twice the time of flight through one single linac

$$\text{so } t_{\text{DB}} = 2 L_{\text{main}} / c, \quad 148 \mu\text{s for the 3 TeV CLIC}$$

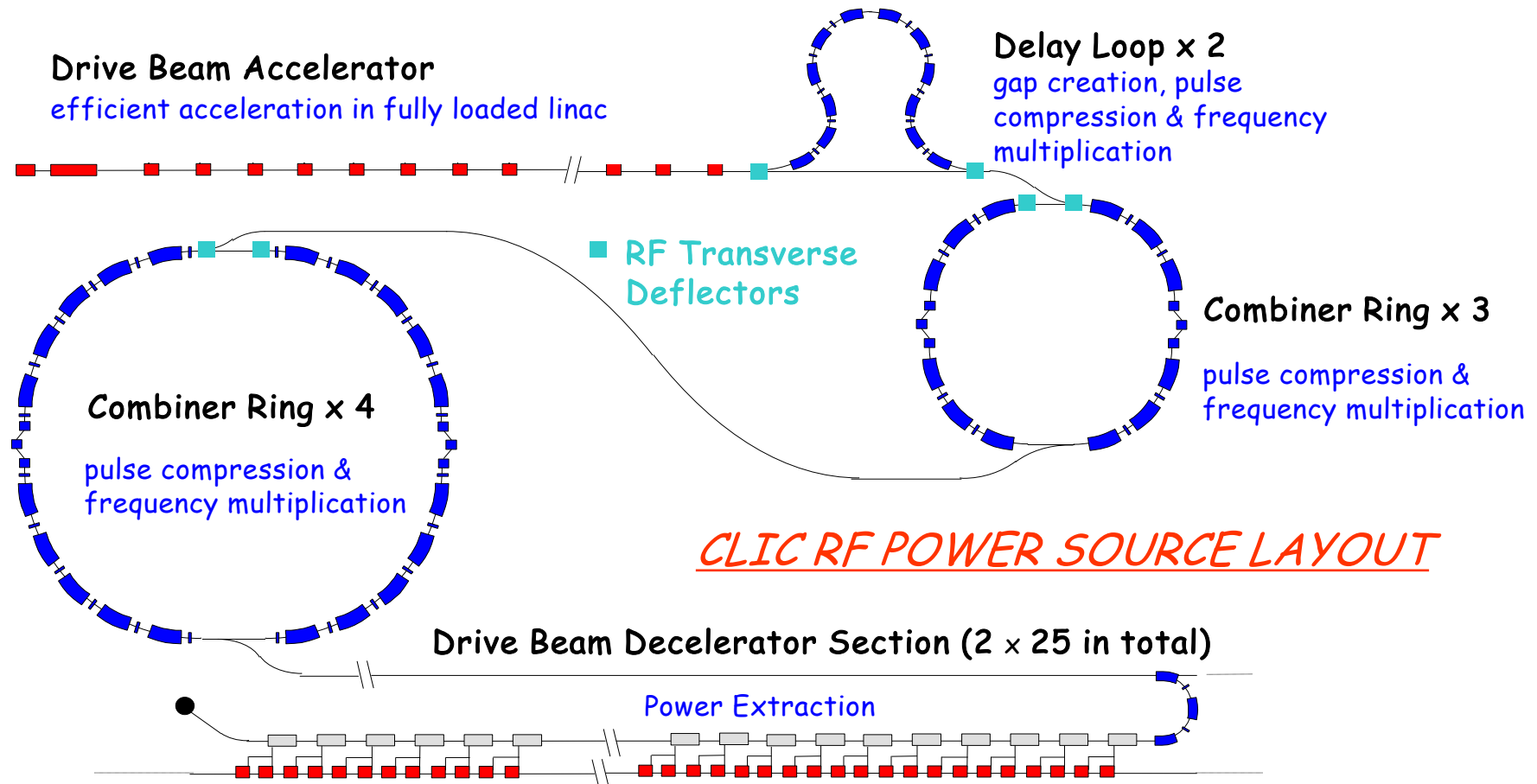

Drive beam time structure - initial

240 ns

148 μ s train length - 25 x 24 sub-pulses
4.2 A - 2.4 GeV - 60 cm between bunches

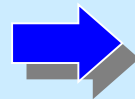

Drive beam time structure - final

240 ns

5.8 μ s

25 pulses - 101 A - 2.5 cm between bunches

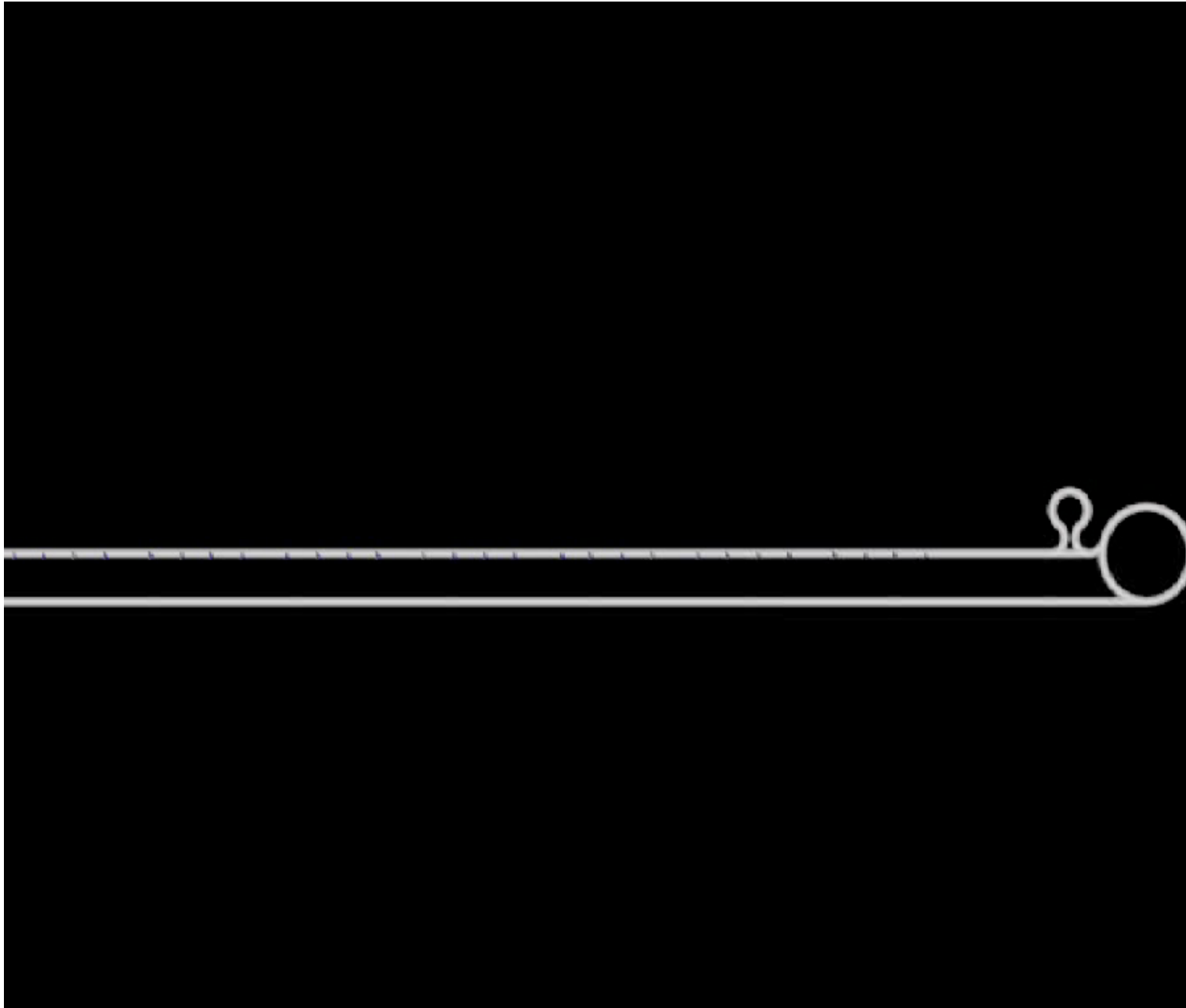

Alexandra
Andersson

- **efficient** power transfer from RF to the beam needed

“Standard” situation:

- **small** beam loading
- power at structure exit lost in load

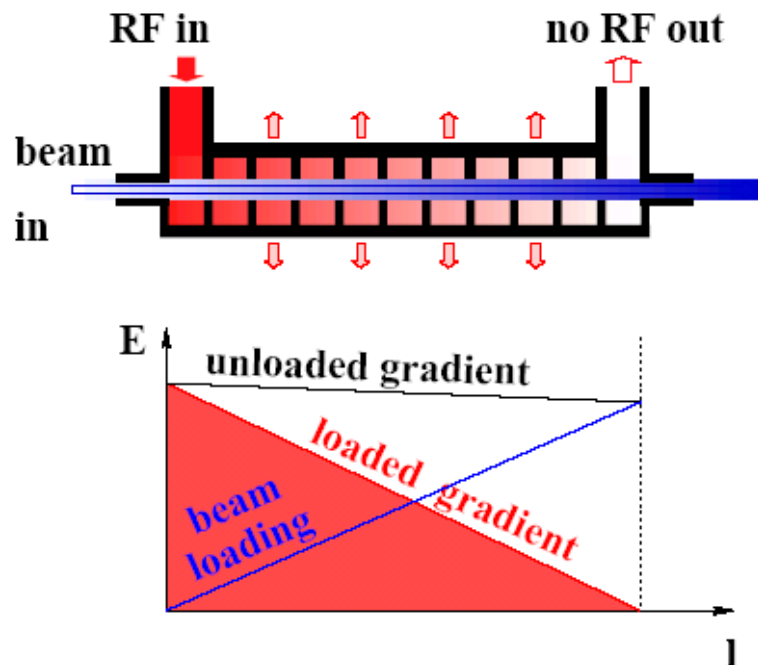
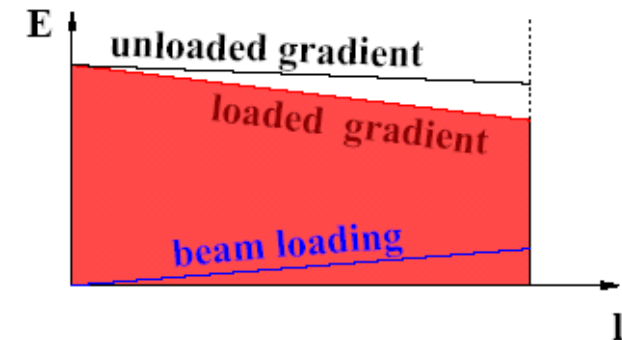

“Efficient” situation:

- high beam current
- **high** beam loading
- no power flows into load
- $V_{ACC} \approx 1/2 V_{unloaded}$

- Disadvantage: any current variation changes energy gain

$$\frac{dV / V}{dI_{beam} / I_{beam}} = - \frac{I_{beam}}{I_{opt}}$$

at full loading, 1% current variation = 1% voltage variation

at 20% loading, 1% current variation = 0.2% voltage variation

- Requires **high current stability**
- Stable beam successfully demonstrated in CTF3
- > 95% efficiency**

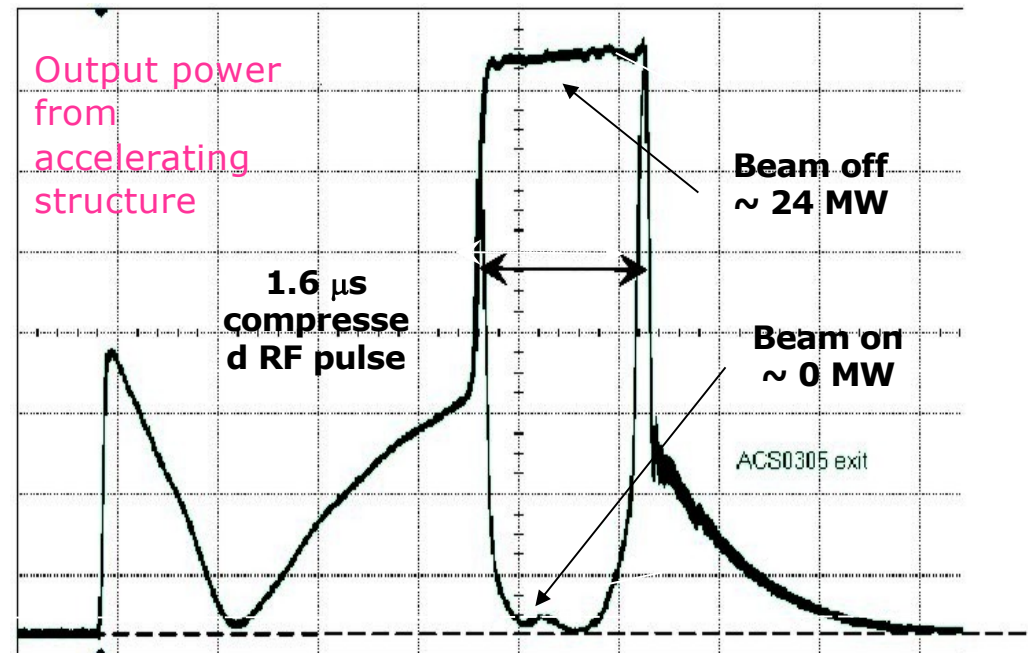

- basic principle of **drive beam** generation
- transform very long pulses into short pulses with higher power and higher frequency
- use **RF deflectors** to **interleave** bunches
 - => double power
 - => double frequency

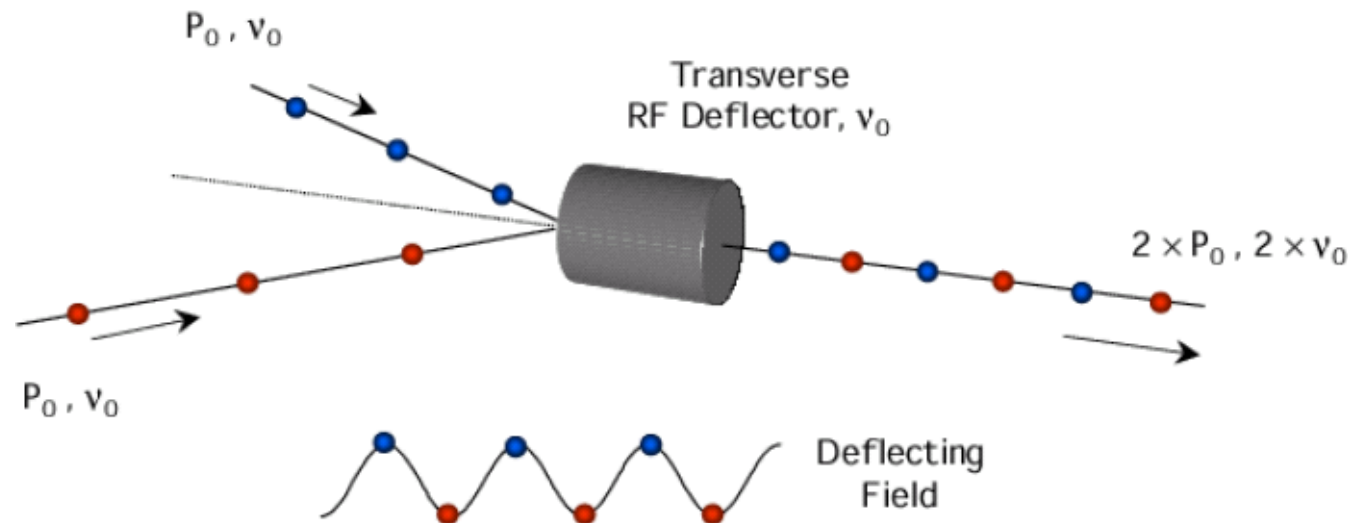

- double repetition frequency and current
- parts of bunch train delayed in loop
- RF deflector combines the bunches ($f_{defl} = \text{bunch rep. frequency}$)
- Path length corresponds to beam pulse length

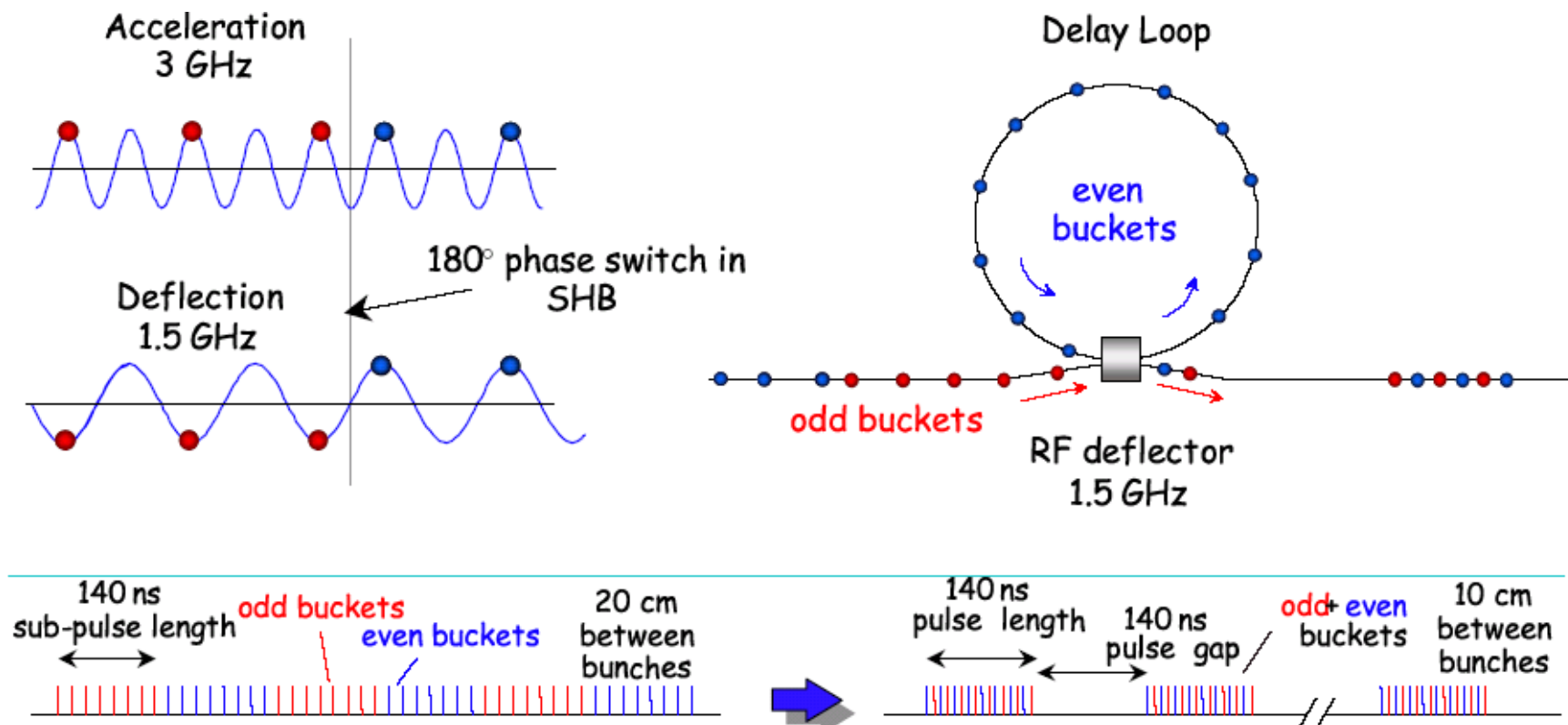

- combination **factors** up to 5 reachable in a ring

$$C_{ring} = (n + 1/4) \lambda$$

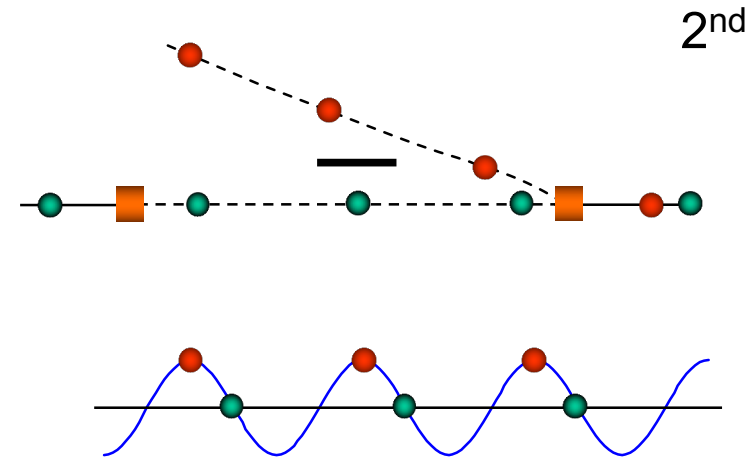
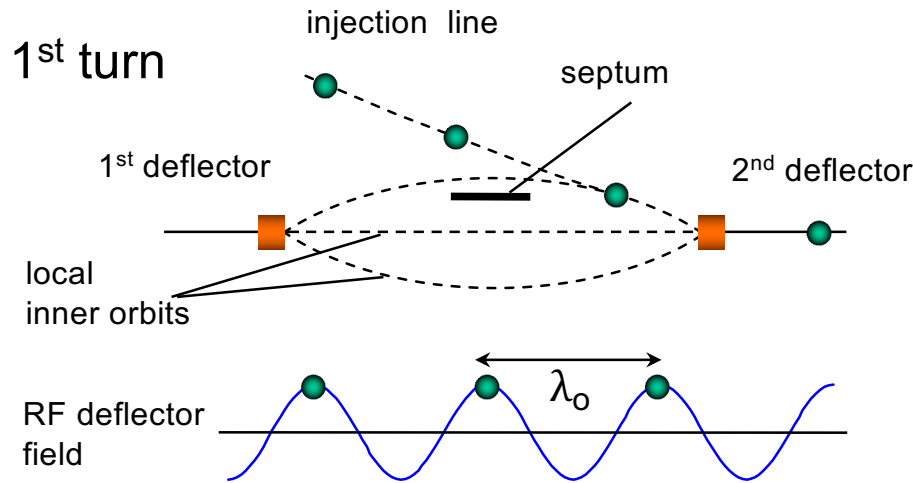

C_{ring} has to correspond to the distance of pulses from the previous combination stage!

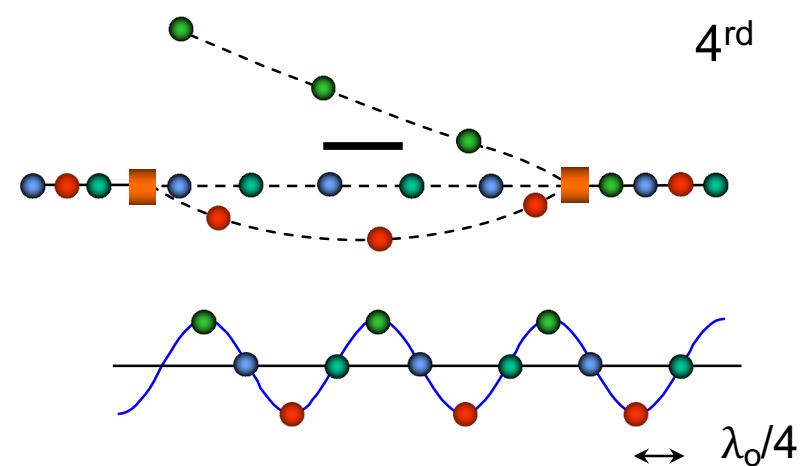
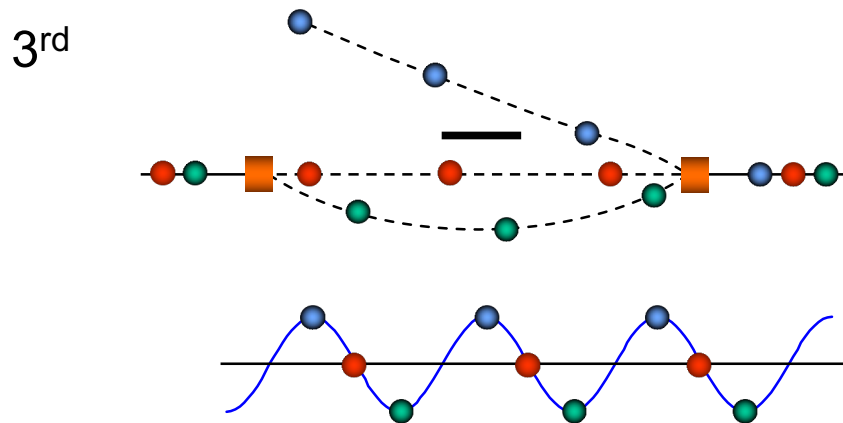

Combination factor 5

CTF3 - PRELIMINARY PHASE
2001/2002

Successful low-charge demonstration of
electron pulse combination and bunch
frequency multiplication by up to factor 5

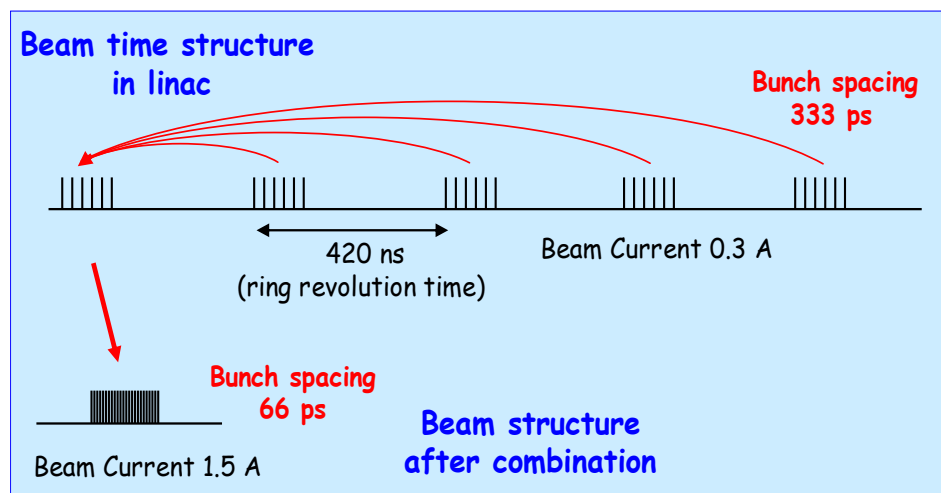
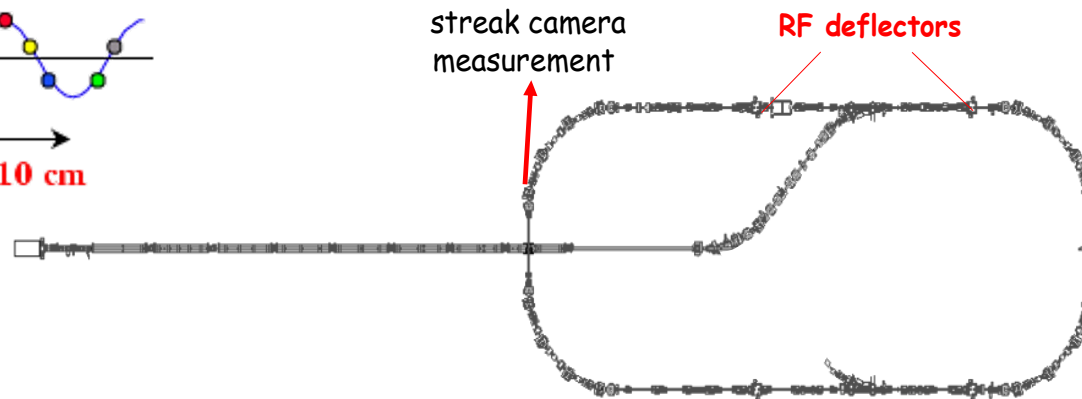
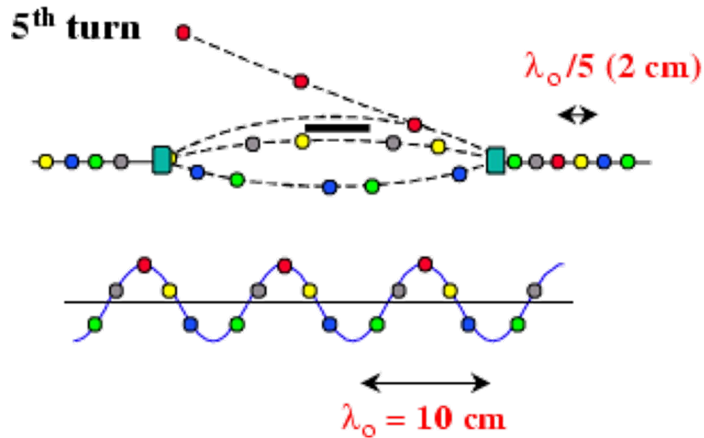

Streak camera image of
beam time structure evolution

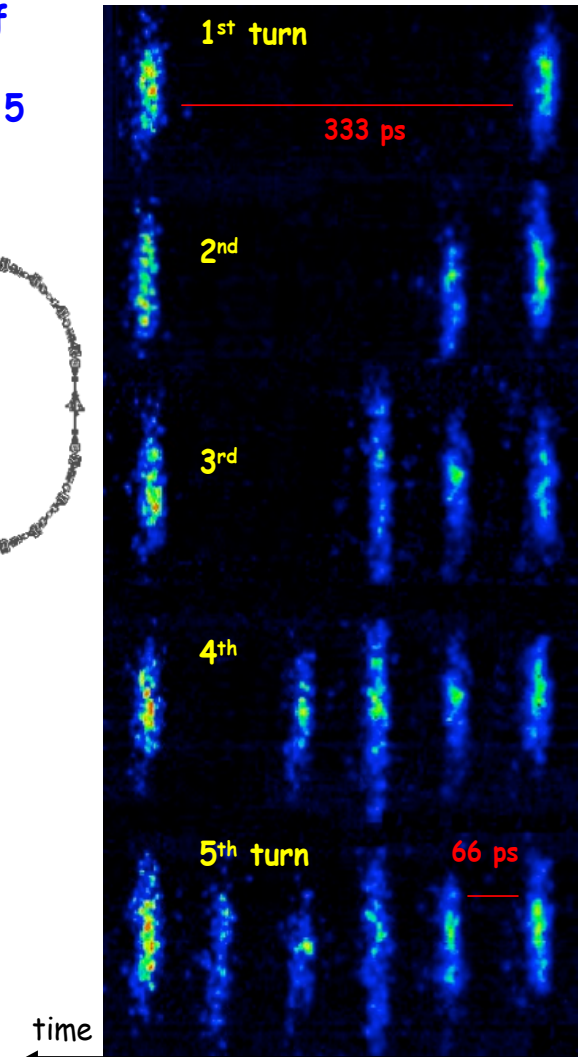

RF injection in combiner ring

Combination factor 4

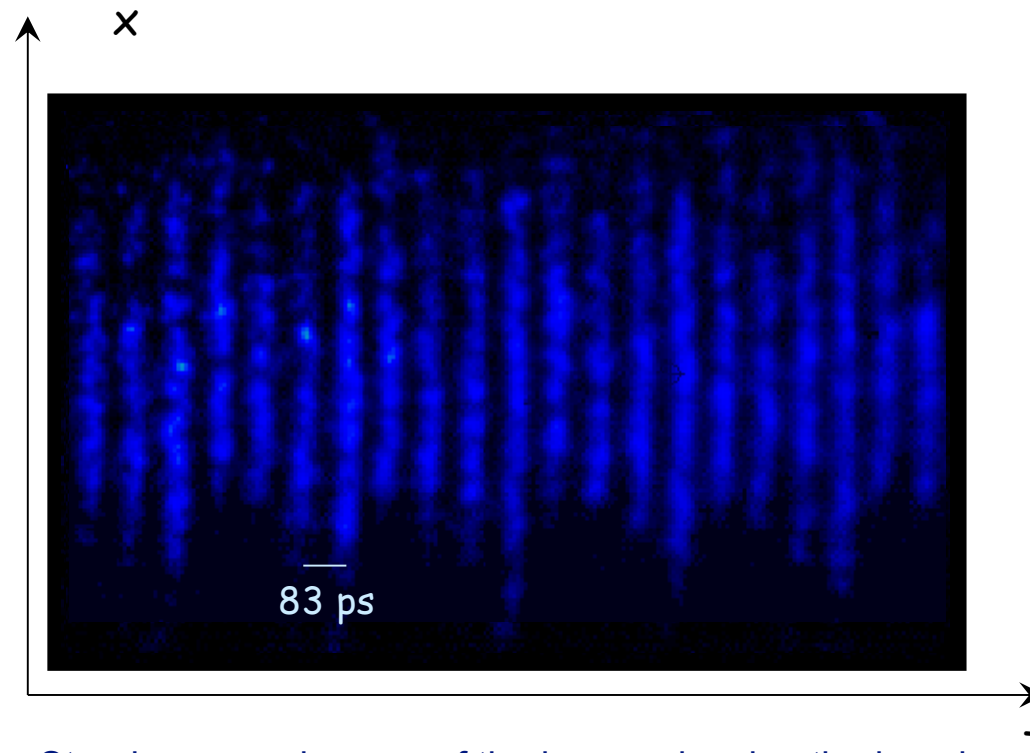

Streak camera images of the beam, showing the bunch combination process

A first ring combination test was performed in 2002, *at low current and short pulse*, in the CERN Electron-Positron Accumulator (EPA), properly modified

- demonstrate remaining CLIC feasibility issues, in particular:
 - Drive Beam generation (fully loaded acceleration, bunch frequency multiplication)
 - CLIC accelerating structures
 - CLIC power production structures (PETS)

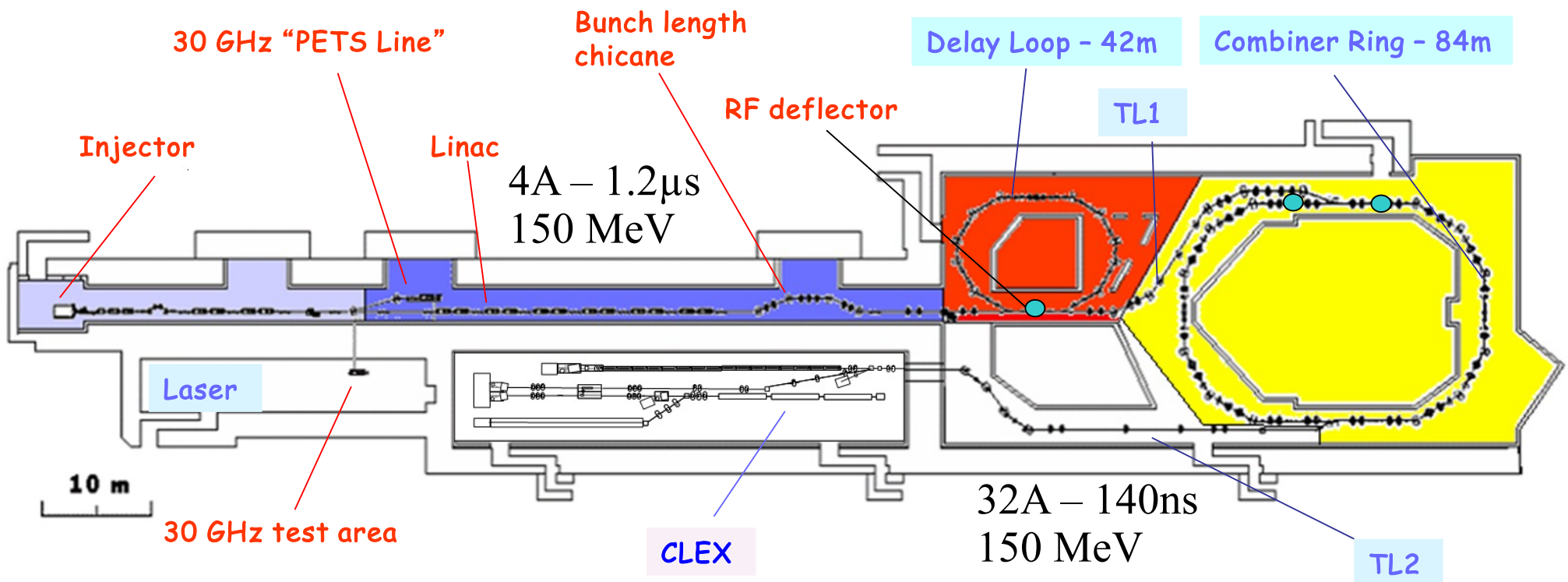

- combined operation of Delay Loop and Combiner Ring (factor 8 combination)
- ~26 A combination reached, nominal 140 ns pulse length
- => **Full drive beam generation, main goal of 2009, achieved**

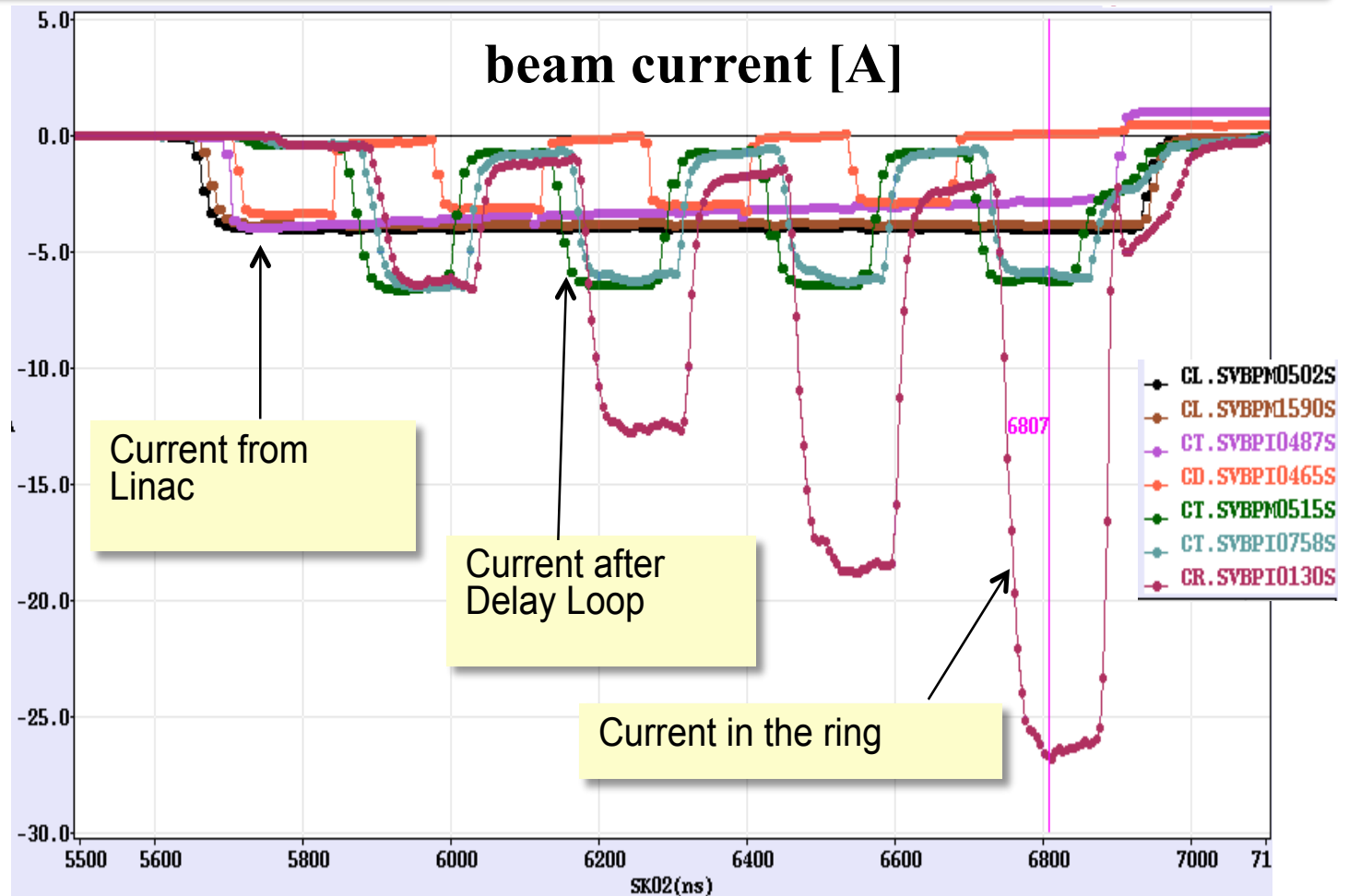
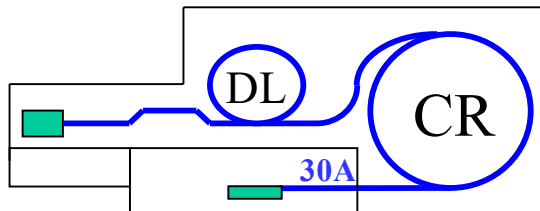

- must **extract** efficiently **>100 MW power** from high current drive beam
- passive microwave device in which bunches of the drive beam interact with the impedance of the periodically loaded waveguide and generate RF power
- periodically corrugated structure with low impedance (big a/λ)
- ON/OFF mechanism

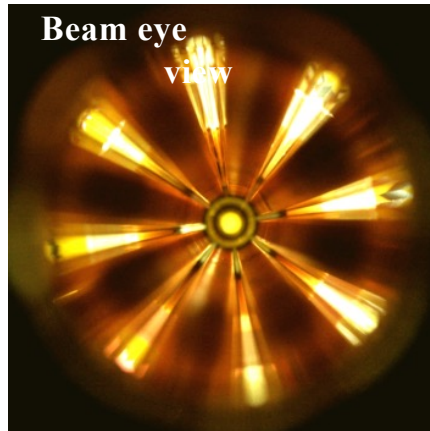
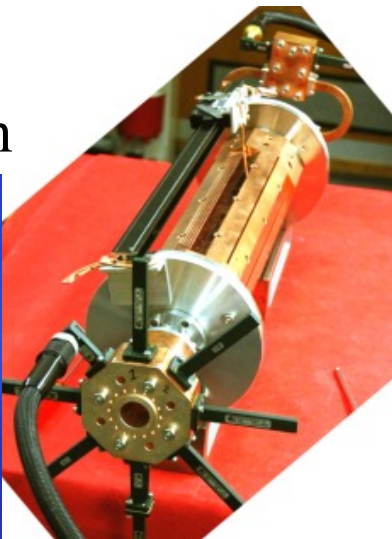
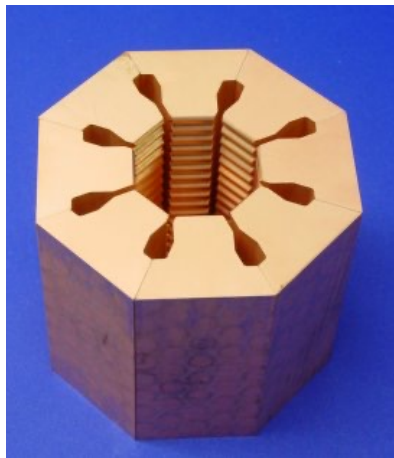

The power produced by the bunched (ω_0) beam in a constant impedance structure:

Design input parameters

PETS design

$$P = I^2 L^2 F_b^2 \omega_0 \frac{R/Q}{4v_g}$$

P - RF power, determined by the accelerating structure needs and the module layout.

I - Drive beam current

L - Active length of the PETS

F_b - single bunch form factor (≈ 1)

- RF breakdowns can occur
=> no acceleration and deflection

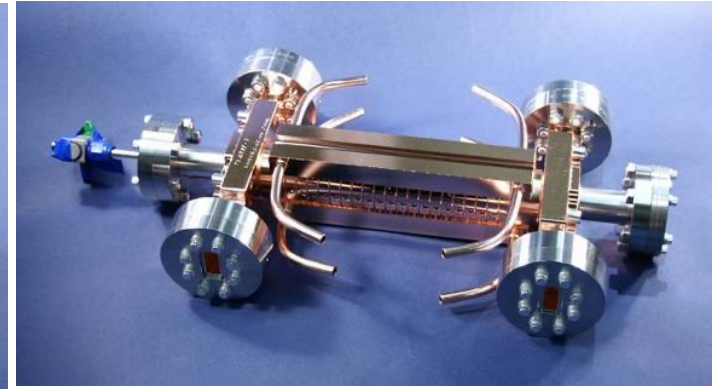
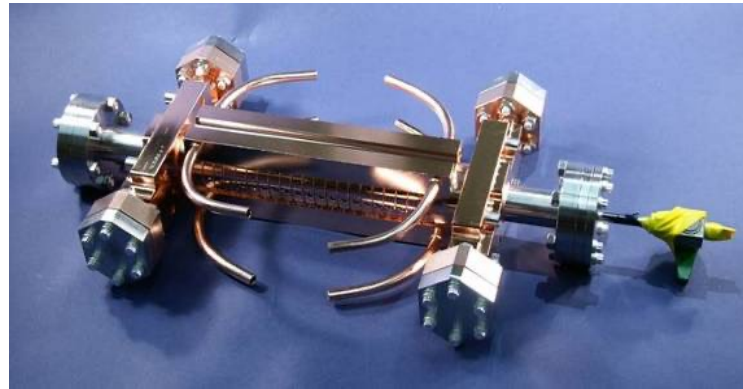

- Goal: $3 \cdot 10^{-7}/\text{m}$ breakdowns at 100 MV/m loaded gradient at 230 ns pulse length
- latest prototypes (T24 and TD24) tested (SLAC and KEK)
- => TD24 reach up to 108 MV/m at nominal CLIC breakdown rate (without damping material)
- Undamped T24 reaches 120MV/m

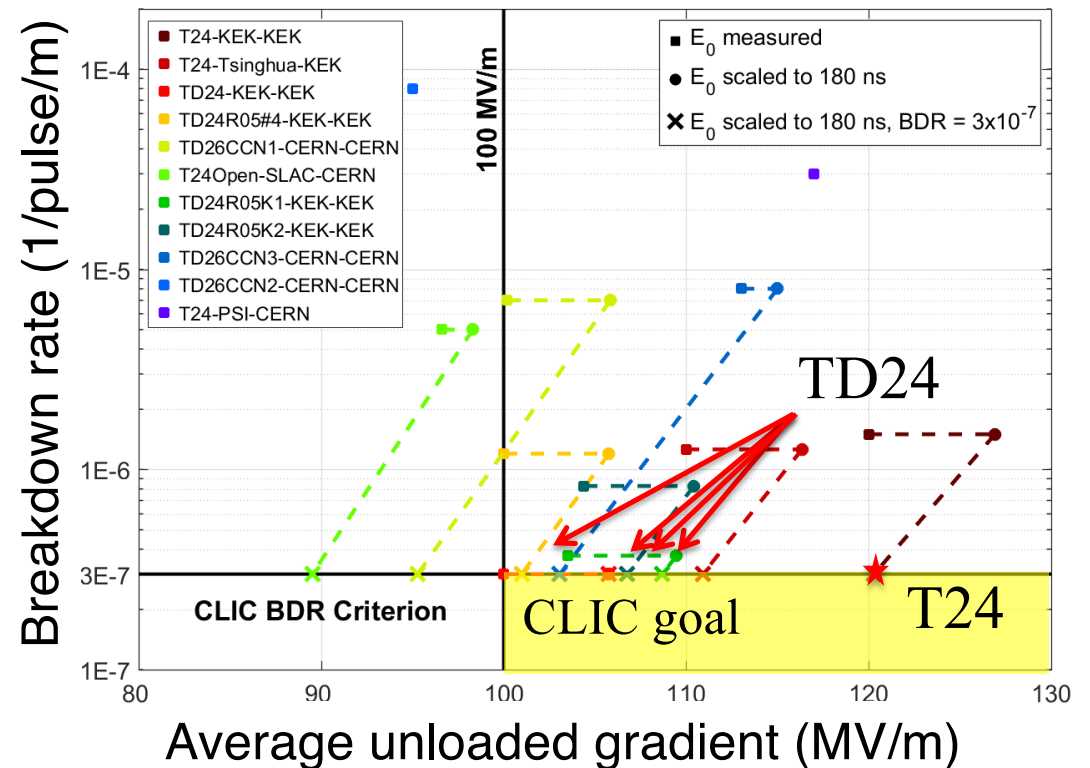

time: **0 0 . 0** ns

Accelerating structure

- The induced fields travel along the PETS structure and build up resonantly

PETS structure

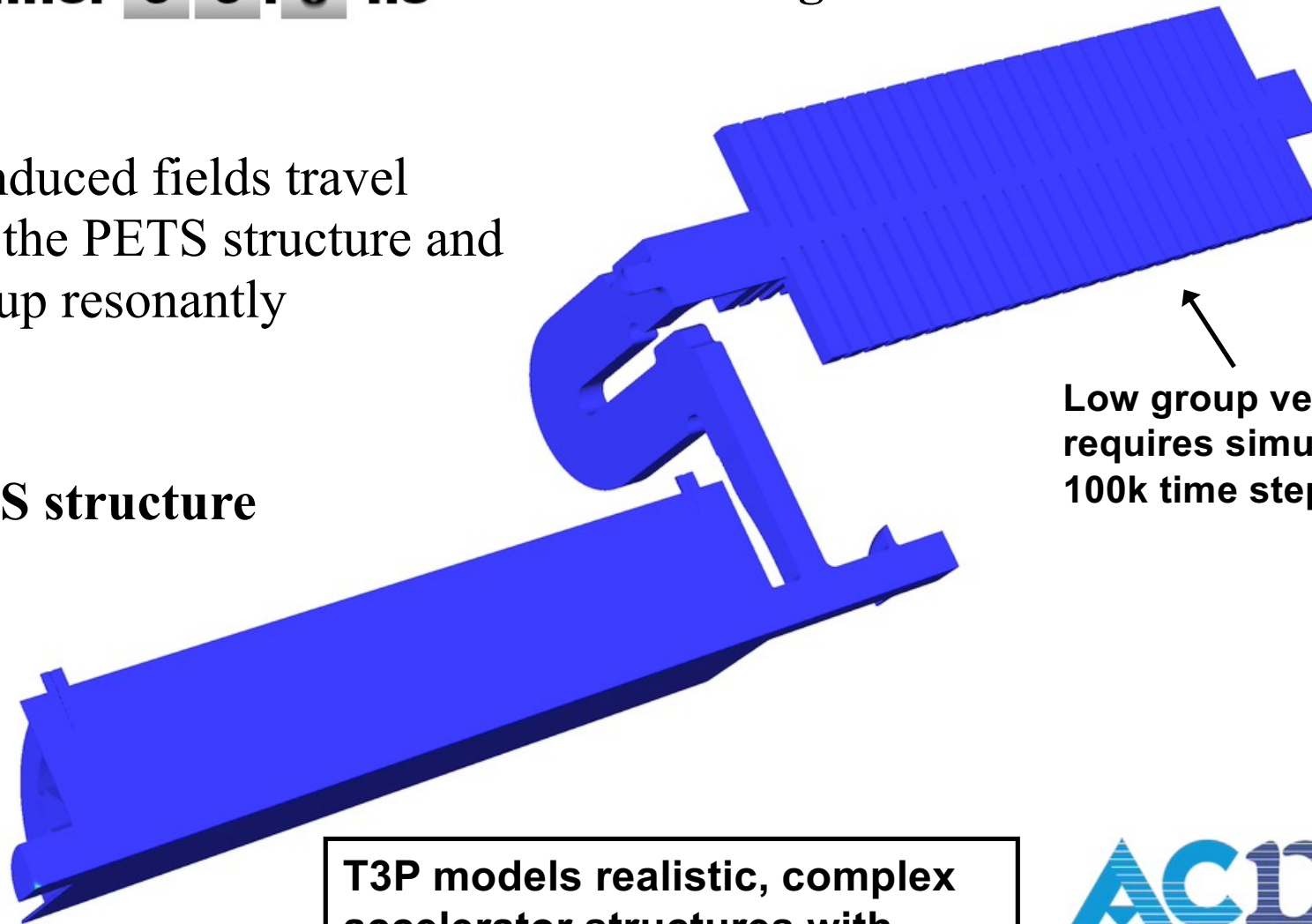

Low group velocity
requires simulations with
100k time steps

T3P models realistic, complex
accelerator structures with
unprecedented accuracy



Arno Candel, SLAC

- Drive beam has high current and high energy spread
- Stable transport in simulations verified experimentally with 13 PETS
- 24 A beam decelerated by $\sim 51\%$, >1.3 GW power produced!
- Good agreement of power production, beam current and deceleration

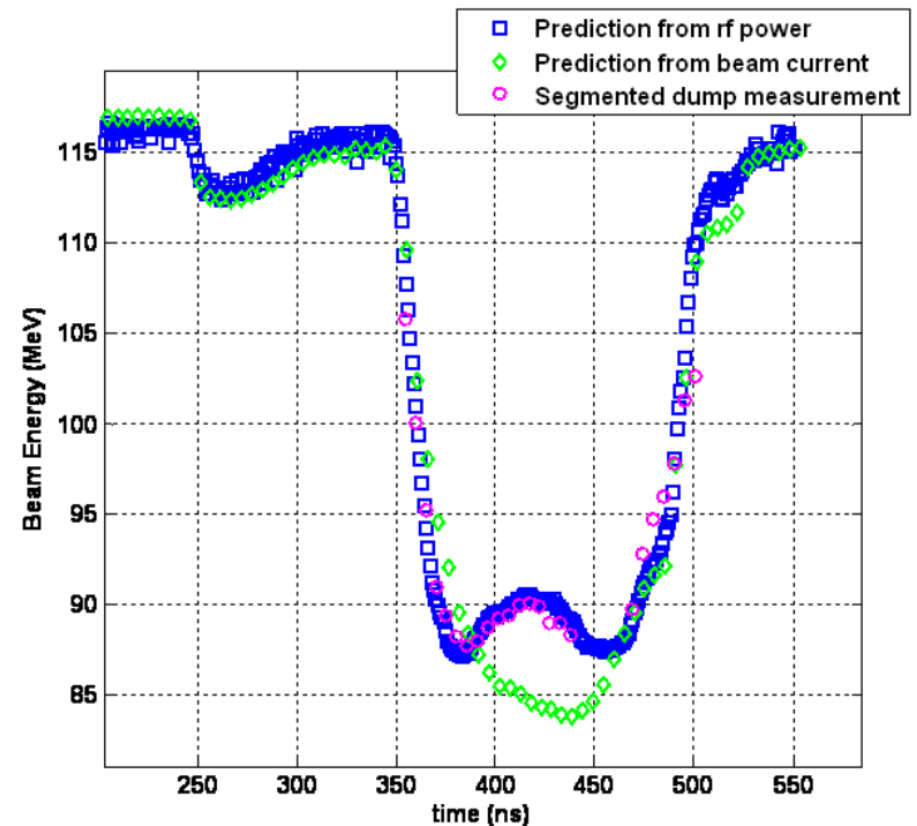
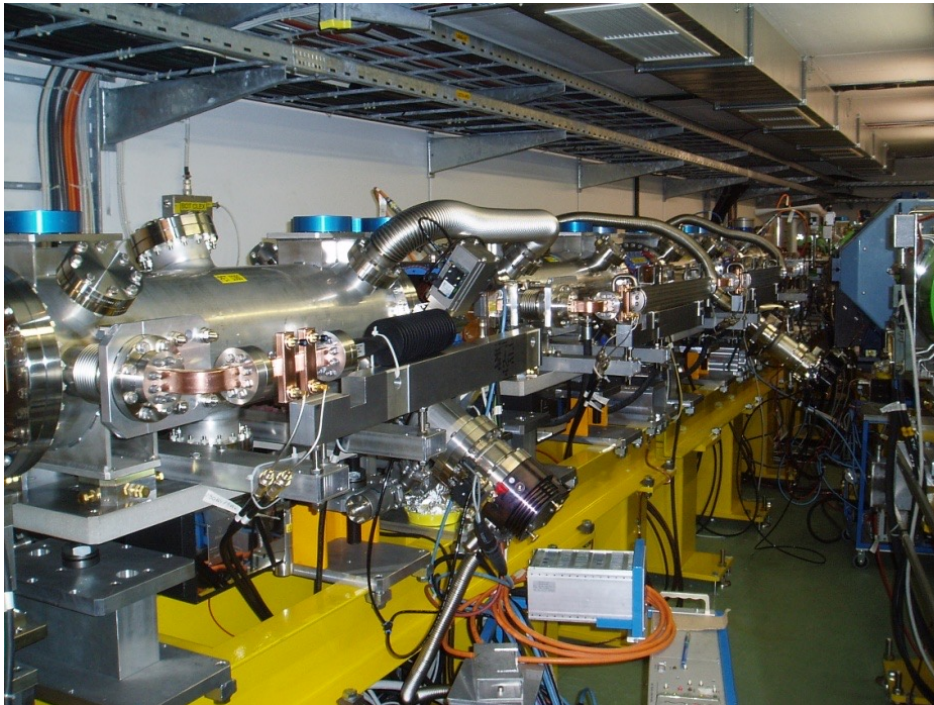

- Maximum probe beam acceleration measured: **31 MeV**
=> Corresponding to a gradient of **145 MV/m**

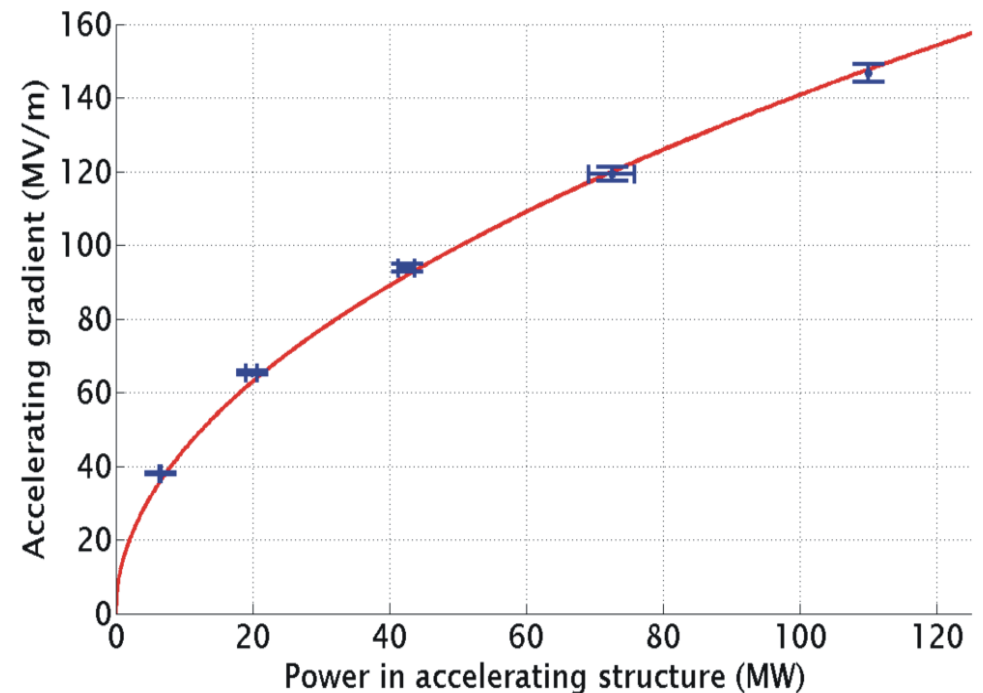
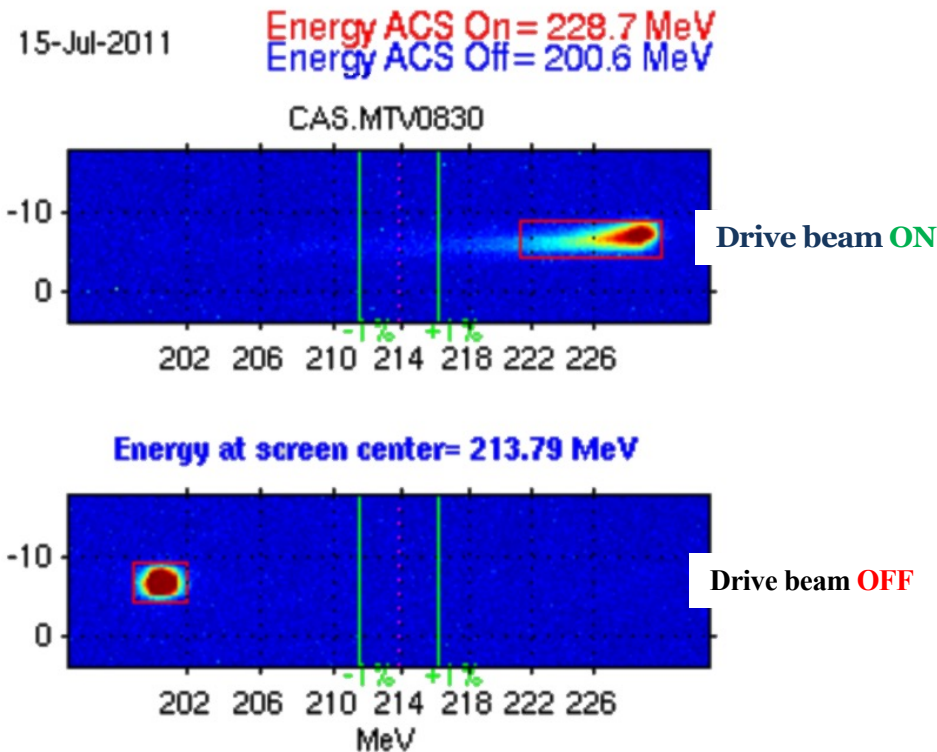
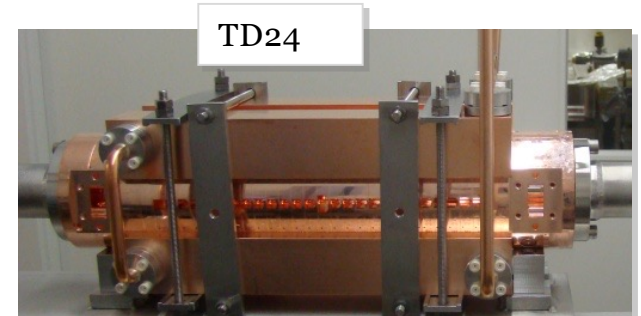

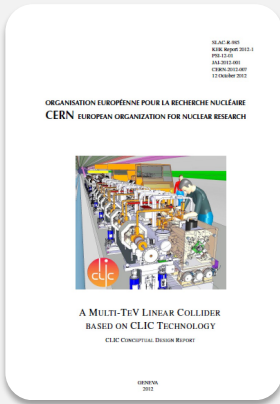

Vol 1: The CLIC accelerator and site facilities (H.Schmickler)

- CLIC concept with exploration over multi-TeV energy range up to 3 TeV
- Feasibility study of CLIC parameters optimized at 3 TeV (most demanding)
- Consider also 500 GeV, and intermediate energy range
- Complete, presented in SPC in March 2011, in print: <https://edms.cern.ch/document/1234244/>

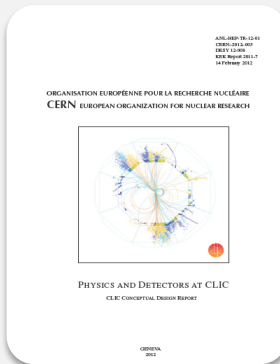

Vol 2: Physics and detectors at CLIC (L.Linssen)

- Physics at a multi-TeV CLIC machine can be measured with high precision, despite challenging background conditions
- External review procedure in October 2011
- Completed and printed, presented in SPC in December 2011 <http://arxiv.org/pdf/1202.5940v1>

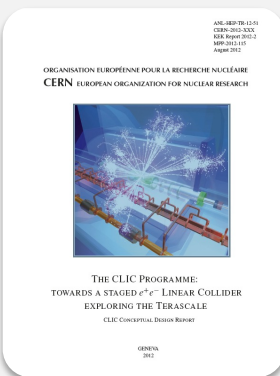

Vol 3: "CLIC study summary" (S.Stapnes)

- Summary and available for the European Strategy process, including possible implementation stages for a CLIC machine as well as costing and cost-drives
- Proposing objectives and work plan of post CDR phase (2012-16)
- Completed and printed, submitted for the European Strategy Open Meeting in September <http://arxiv.org/pdf/1209.2543v1>

In addition, a shorter overview document as input to the European Strategy update, available at:

<http://arxiv.org/pdf/1208.1402v1>

2016:
CLIC Baseline update
After Higgs discovery
<https://cds.cern.ch/record/2210892/>

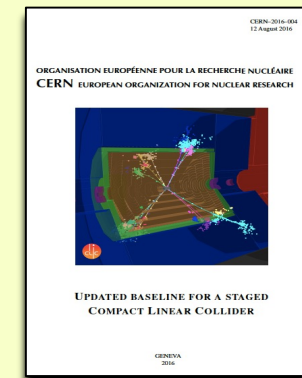

CLIC input to the European Strategy for Particle Physics Update 2018-2020

Formal European Strategy submissions

- The Compact Linear e+e- Collider (CLIC): Accelerator and Detector ([arXiv:1812.07987](https://arxiv.org/abs/1812.07987))
- The Compact Linear e+e- Collider (CLIC): Physics Potential ([arXiv:1812.07986](https://arxiv.org/abs/1812.07986))

Yellow Reports

- CLIC 2018 Summary Report ([CERN-2018-005-M](https://cds.cern.ch/record/2311000))
- CLIC Project Implementation Plan ([CERN-2018-010-M](https://cds.cern.ch/record/2311000))
- The CLIC potential for new physics ([CERN-2018-009-M](https://cds.cern.ch/record/2311000))
- Detector technologies for CLIC ([CERN-2019-001](https://cds.cern.ch/record/2311000))

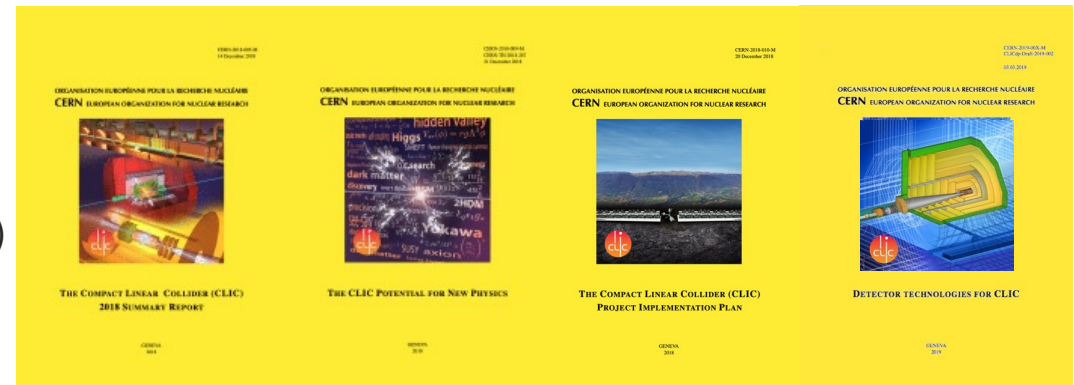

Journal publications

- Top-quark physics at the CLIC electron-positron linear collider ([Journal, arXiv:1807.02441](https://arxiv.org/abs/1807.02441))
- Higgs physics at the CLIC electron-positron linear collider ([Journal, arXiv:1608.07538](https://arxiv.org/abs/1608.07538))

CLICdp notes

- Updated CLIC luminosity staging baseline and Higgs coupling prospects ([CERN Document Server, arXiv:1812.01644](https://cds.cern.ch/record/2311000))
- CLICdet: The post-CDR CLIC detector model ([CERN Document Server](https://cds.cern.ch/record/2311000))
- A detector for CLIC: main parameters and performance ([CERN Document Server, arXiv:1812.07337](https://cds.cern.ch/record/2311000))
- Snowmass white paper (March 22) : <https://arxiv.org/abs/2203.09186>

Link: <http://clic.cern/european-strategy>

- Linear e⁺/e⁻ Collider the only realistic approach to highest energy
- **Many challenges!!!**
- Efficient acceleration
 - RF system
 - High gradient
- Extremely small beam sizes
 - Damping ring performance is crucial
 - Emittance preservation
 - Alignment and stabilisation
- **Much interesting work left to do!!!**
- Much more detailed lectures at former ILC schools
<http://agenda.linearcollider.org/event/6906> or
<http://agenda.linearcollider.org/event/7333>
- Some nice animations for CLIC on <http://clic.cern>

LCWS 2024

8–11 July 2024, Tokyo, Japan

[https://agenda.linearcollider.org/
event/10134/](https://agenda.linearcollider.org/event/10134/)