

# Linear Accelerators

*David Alesini  
(INFN-LNF, Frascati, Rome, Italy)*

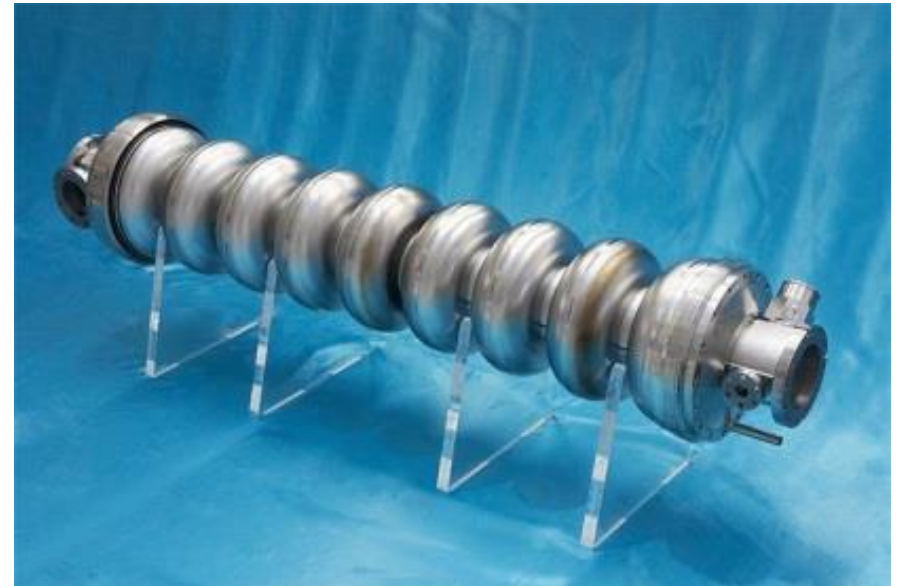

# LINAC APPLICATIONS

~10<sup>4</sup> LINACs operating around the world

Injectors for synchrotrons



Free Electron Lasers

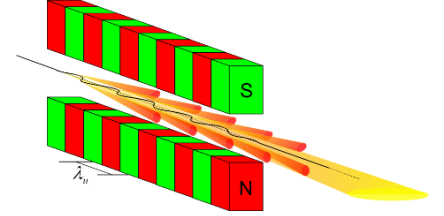

Medical applications:  
radiotherapy



Nuclear waste treatment and  
controlled fission for energy  
production (ADS)

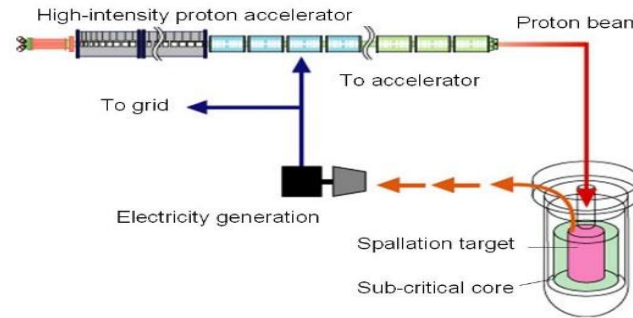

Spallation sources for neutron  
production

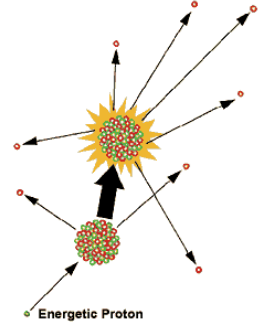

Industrial  
applications

National security

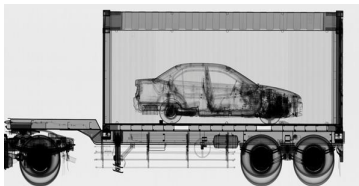

Material  
treatment



Ion implantation



Material/food  
sterilization



Material testing for fusion  
nuclear reactors

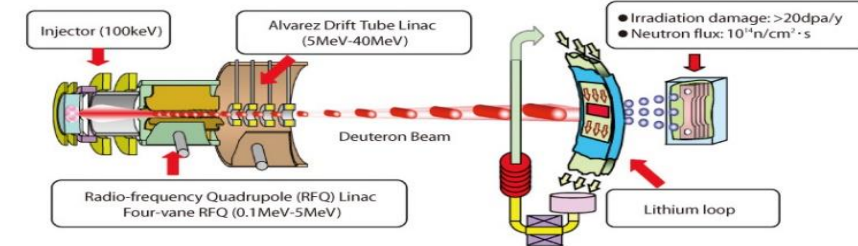

# LINAC: BASIC DEFINITION AND MAIN COMPONENTS

LINAC (linear accelerator) is a system that allows to accelerate charged particles through a linear trajectory by electromagnetic fields.

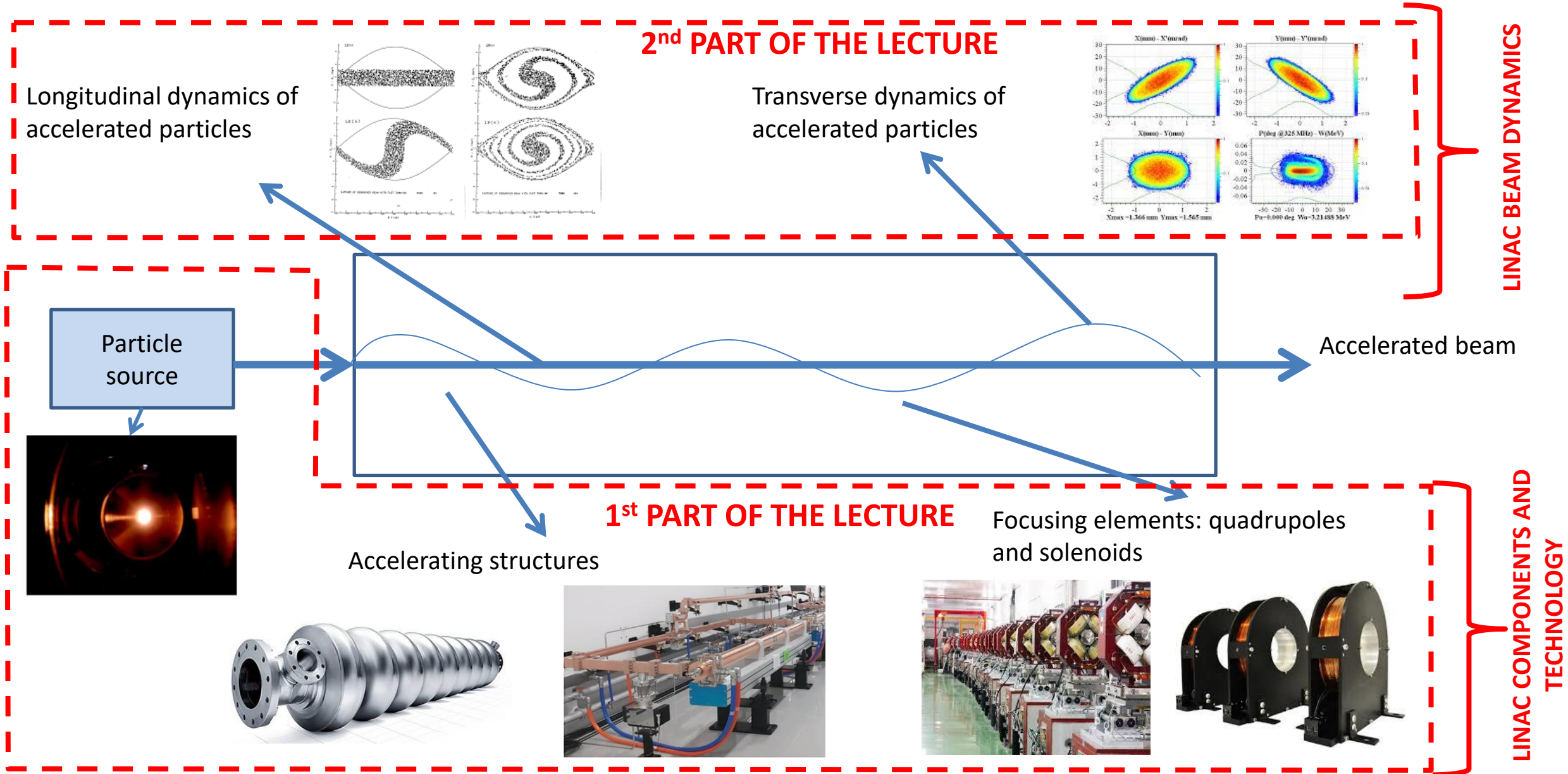

# LINAC TECHNOLOGY

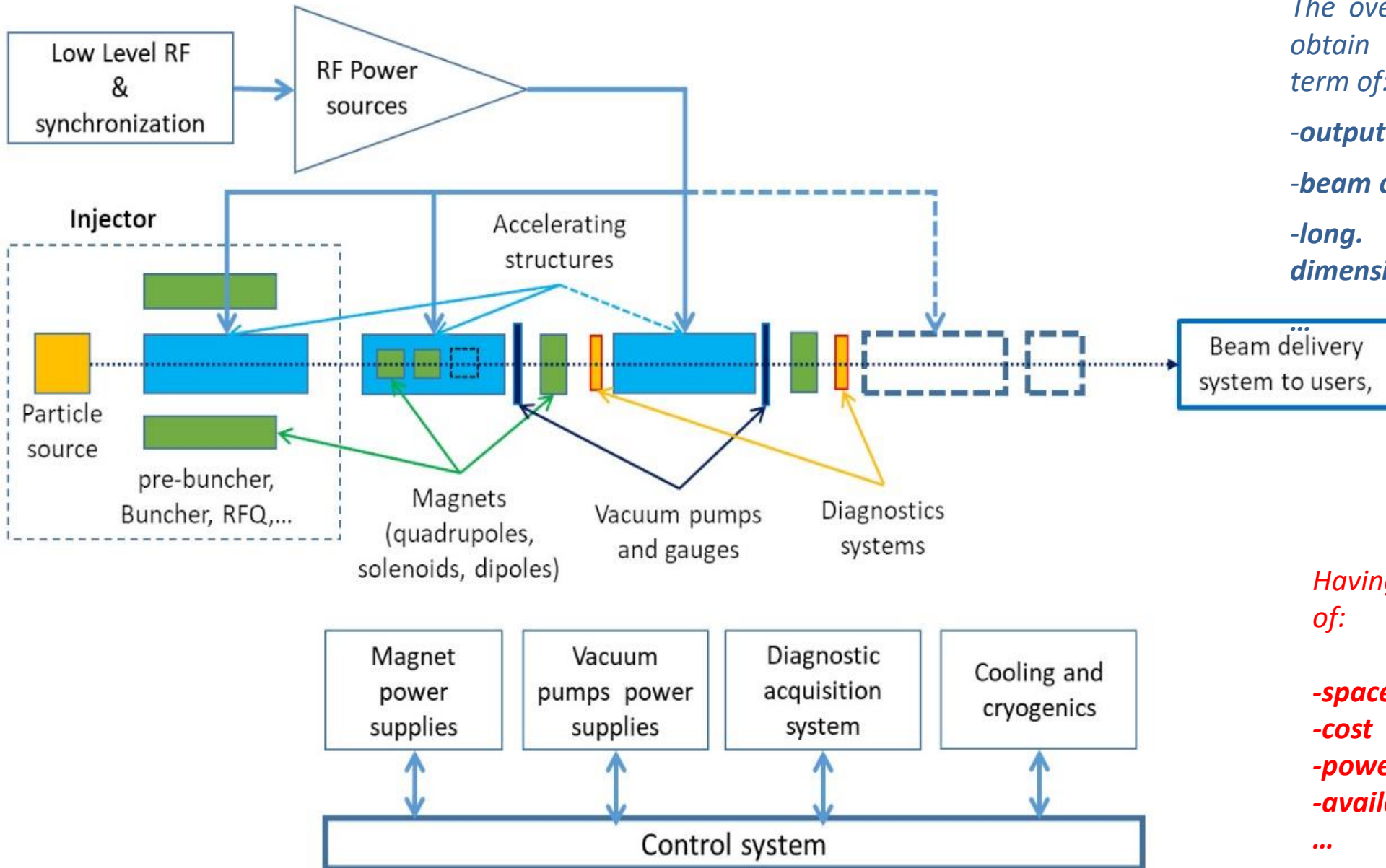

The overall LINAC has to be designed to obtain the **desired beam parameters** in term of:

- output energy/energy spread
- beam current (charge)
- long. and transverse beam dimensions/divergence (emittance)

Having, in general, **constraints** in term of:

- space
- cost
- power consumption
- available power sources
- ...

# LORENTZ FORCE: ACCELERATION AND FOCUSING

The basic equation that describes the acceleration/bending/focusing processes is the Lorentz Force.  
Particles are **accelerated through electric fields** and are **bended and focused through magnetic fields**.

$$\frac{d\vec{p}}{dt} = q (\vec{E} + \vec{v} \times \vec{B})$$

$\vec{p} = momentum$   
 $m = mass$   
 $\vec{v} = velocity$   
 $q = charge$

## ACCELERATION

To accelerate, we need a force in the direction of motion

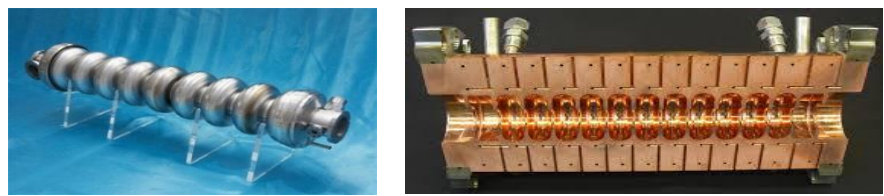
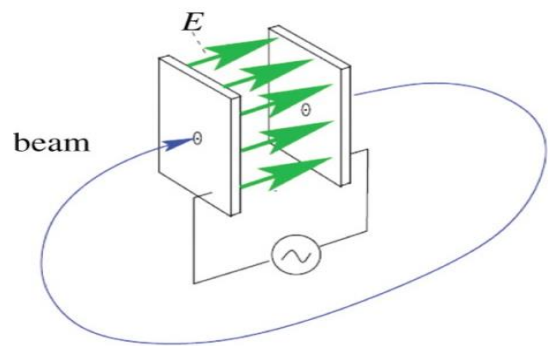

Longitudinal Dynamics

## BENDING AND FOCUSING

2<sup>nd</sup> term always perpendicular to motion => no energy gain

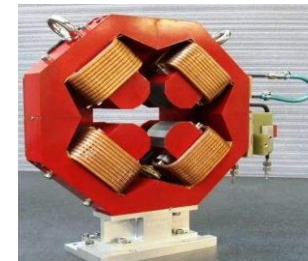
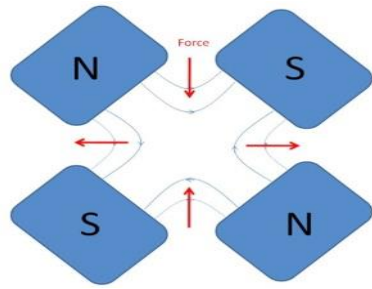
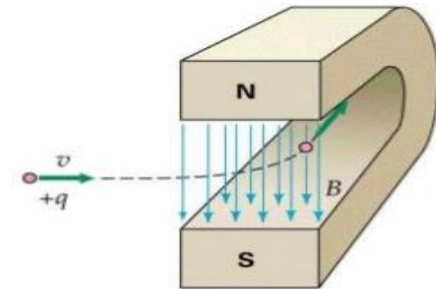

Transverse Dynamics

# ACCELERATION: SIMPLE CASE

The **first historical linear particle accelerator** was built by the Nobel prize Wilhelm Conrad Röntgen (1900). It consisted in a vacuum tube containing a cathode connected to the negative pole of a DC voltage generator. **Electrons emitted by the heated cathode** were accelerated while flowing to another electrode connected to the positive generator pole (anode). Collisions between the energetic electrons and the anode produced **X-rays**.

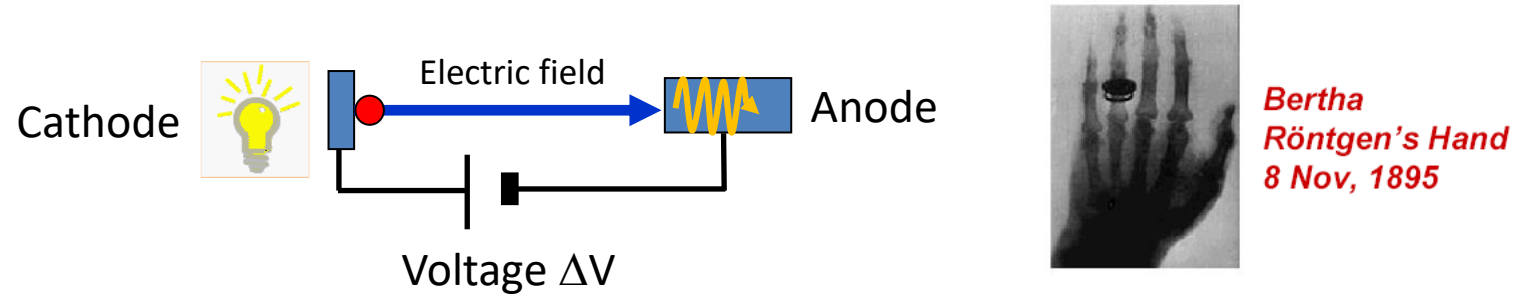

The **energy gained** by the electrons travelling from the cathode to the anode is equal to their charge multiplied the DC voltage between the two electrodes.

$$\frac{d\vec{p}}{dt} = q \vec{E} \Rightarrow \Delta E = q\Delta V$$

$\vec{p}$  = momentum

$q$  = charge

$E$  = energy

Particle energies are typically expressed in electron-volt [eV], equal to the energy gained by 1 electron accelerated through an electrostatic potential of 1 volt:  
1 eV=1.6x10<sup>-19</sup> J

# PARTICLE VELOCITY VS ENERGY: LIGHT AND HEAVY PARTICLES

Single particle

rest mass  $m_0$   
 rest energy  $E_0 (=m_0c^2)$   
 total energy  $E$   
 relativistic mass  $m$   
 velocity  $v$   
 momentum  $p (=mv)$   
 Kinetic energy  $W=E-E_0$

Relativistic factor  
 $\beta=v/c (<1)$   
 Relativistic factor  
 $\gamma=E/E_0 (\geq 1)$   
 +  
 $E^2 = E_0^2 + p^2 c^2$



$$\beta = \sqrt{1 - 1/\gamma^2}$$

$$\gamma = 1/\sqrt{1 - \beta^2} \quad (m = \gamma m_0)$$

$$W = E - E_0 = (\gamma - 1)m_0c^2 \underset{\text{if } \beta \ll 1}{\approx} \frac{1}{2}m_0v^2$$

$$\beta = \sqrt{1 - \frac{1}{\gamma^2}} = \sqrt{1 - \left(\frac{E_0}{E}\right)^2} = \sqrt{1 - \left(\frac{E_0}{E_0 + W}\right)^2}$$

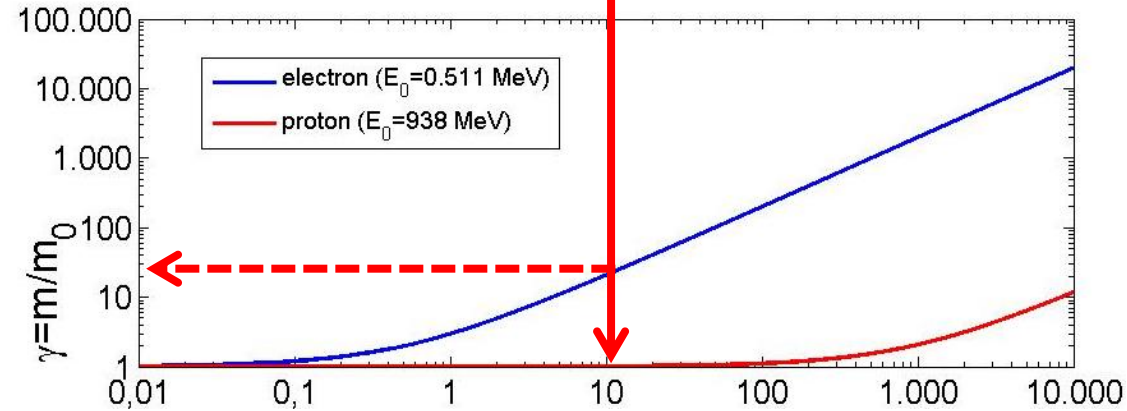
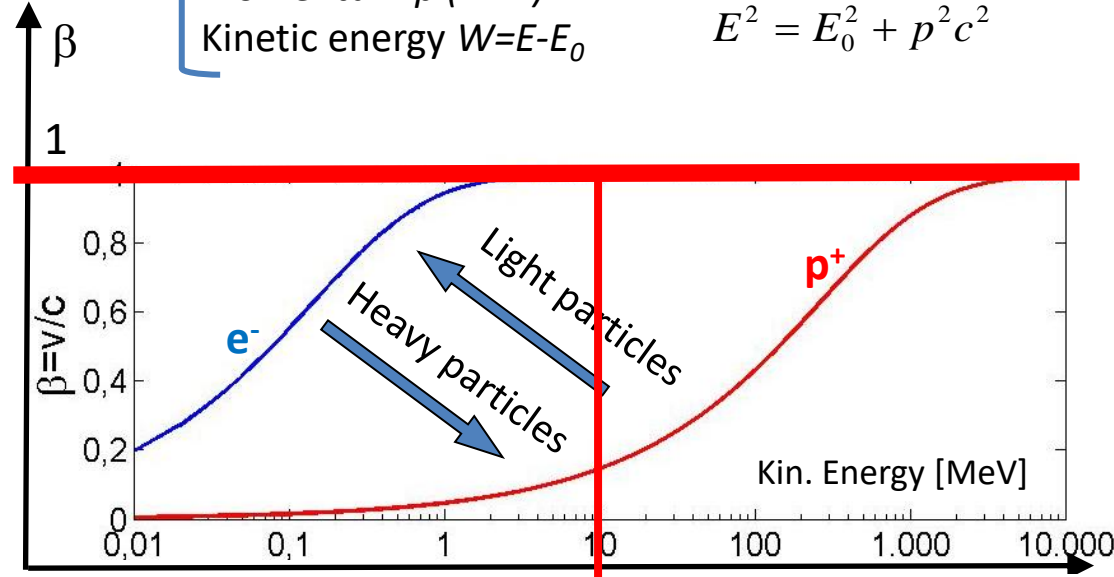

⇒ **Light particles** (as **electrons**) are practically fully relativistic ( $\beta \approx 1$ ,  $\gamma \gg 1$ ) at relatively low energy and **reach a constant velocity** ( $\sim c$ ). The acceleration process occurs at constant particle velocity

⇒ **Heavy particles** (**protons and ions**) are typically weakly relativistic and **reach a constant velocity only at very high energy**. The velocity changes a lot during the acceleration process.



⇒ This implies **important differences** in the technical characteristics of the **accelerating structures**. In particular for **protons and ions** we need different types of accelerating structures, **optimized for different velocities** and/or the accelerating structure has to vary its geometry to take into account the velocity variation.

# ELECTROSTATIC ACCELERATORS

To increase the achievable maximum energy, Van de Graaff invented an electrostatic generator based on a **dielectric belt** transporting positive charges to an isolated electrode hosting an **ion source**. The positive ions generated in a large positive potential were accelerated toward ground by the static electric field.

## LIMITS OF ELECTROSTATIC ACCELERATORS

DC voltage as large as  $\sim 10$  MV can be obtained ( $E \sim 10$  MeV). The main limit in the achievable voltage is the **breakdown** due to **insulation** problems.

## APPLICATIONS OF DC ACCELERATORS

DC particle accelerators are in operation worldwide, typically at  $V < 15$  MV ( $E_{\max} = 15$  MeV),  $I < 100$  mA.

They are used for:

- $\Rightarrow$  material analysis
- $\Rightarrow$  X-ray production,
- $\Rightarrow$  ion implantation for semiconductors
- $\Rightarrow$  first stage of acceleration (particle sources)

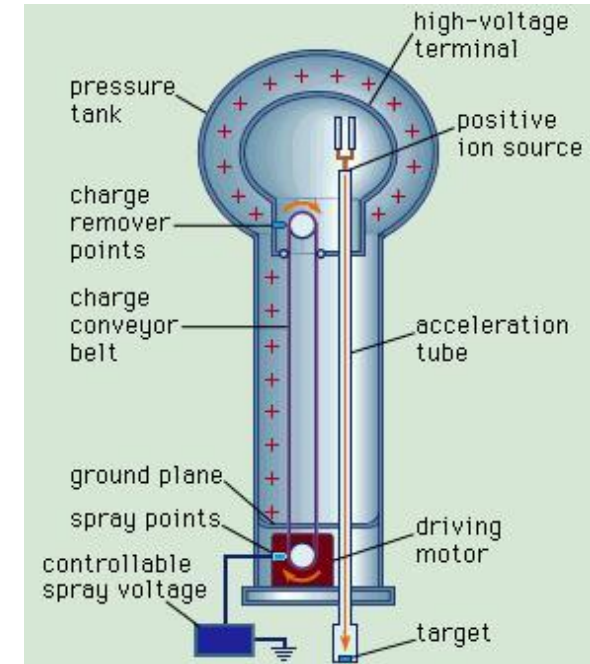
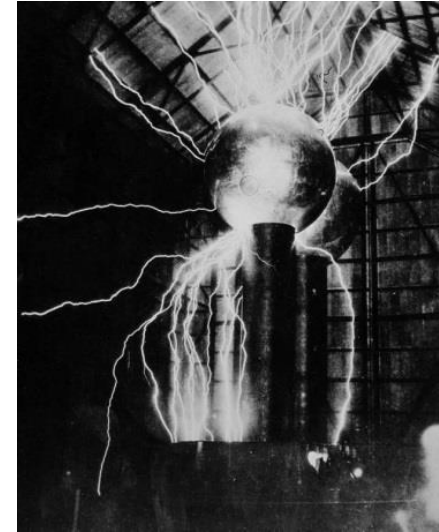

750 kV Cockcroft-Walton  
Linac2 injector at CERN from 1978 to 1992

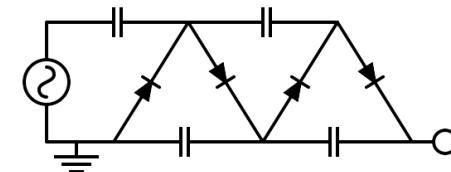
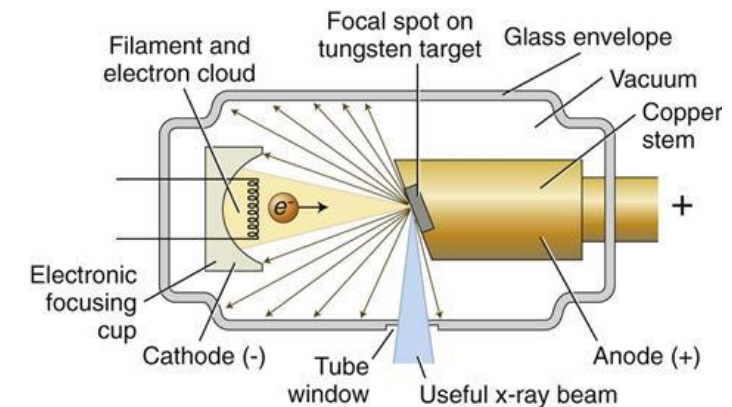



# RF ACCELERATORS : WIDERÖE “DRIFT TUBE LINAC” (DTL) (protons and ions)

Basic idea: the particles are accelerated by the electric field in the gap between electrodes connected alternatively to the poles of an AC generator. This original idea of **Ising** (1924) was implemented by **Wideroe** (1927) who applied a sine-wave voltage to a sequence of **drift tubes**. The particles **do not experience any force while travelling inside the tubes** (equipotential regions) and are **accelerated across the gaps**. This kind of structure is called **Drift Tube LINAC (DTL)**.

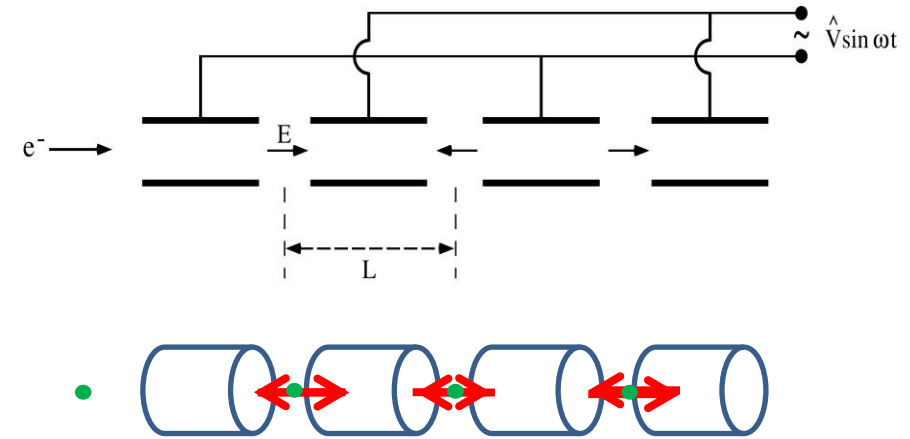

⇒ If the **length of the tubes (or, equivalently, the distances between the centers of the accelerating gaps)** increases with the particle velocity during the acceleration such that the **time of flight between gaps is kept constant and equal to half of the RF period**, the particles are subject to a **synchronous accelerating voltage** and experience an energy gain of  $\Delta E = q\Delta V$  at each gap crossing.

⇒ In principle a single **RF generator** can be used to indefinitely accelerate a beam, **avoiding the breakdown limitation** affecting the electrostatic accelerators.

⇒ The Wideroe LINAC is the **first RF LINAC**

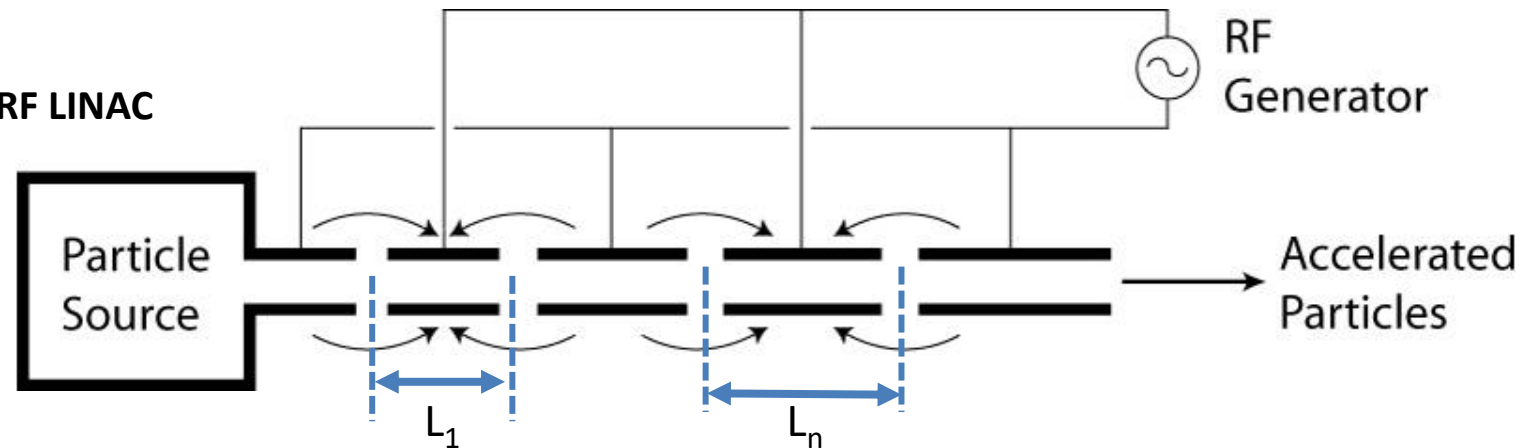

# DC ACCELERATION: ENERGY GAIN

We consider the acceleration between two electrodes in DC.

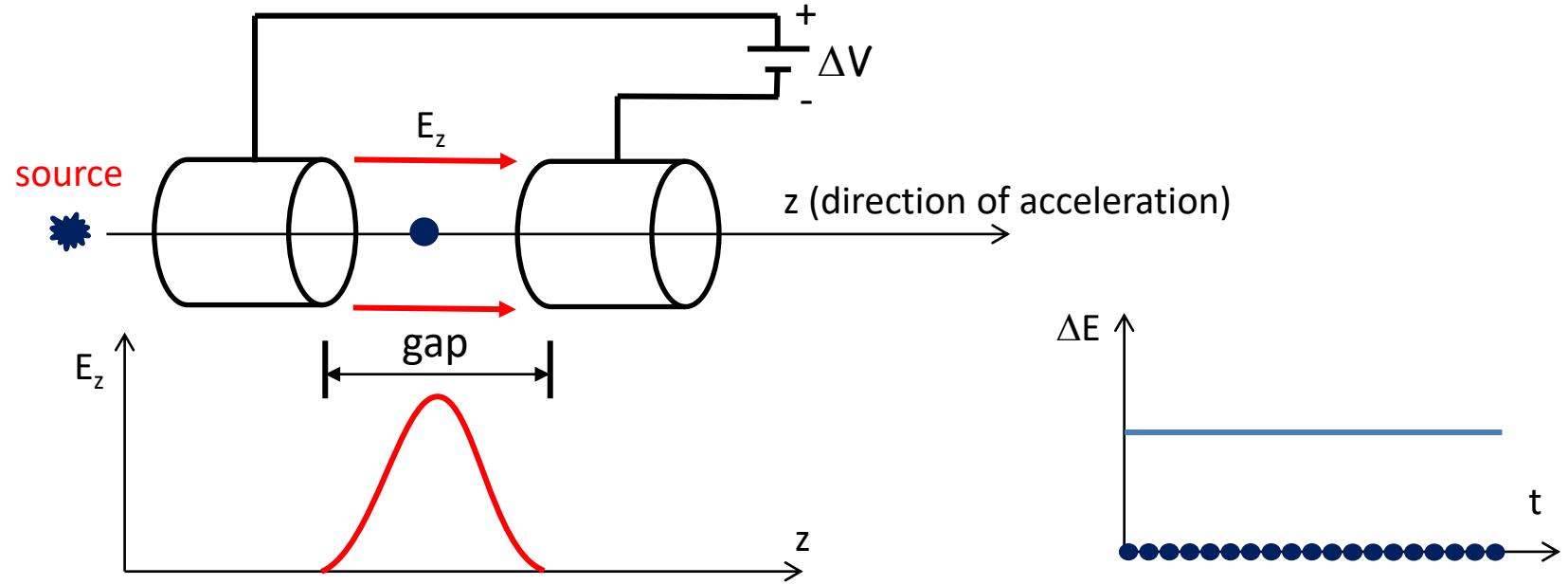

Energy-momentum relation

$$E^2 = E_0^2 + p^2 c^2 \Rightarrow 2E dE = 2p dp c^2 \Rightarrow dE = v \frac{mc^2}{E} dp \Rightarrow dE = v dp$$

Lorentz force

$$\frac{dp}{dt} = qE_z \underbrace{\Rightarrow v}_{z=vt} \frac{dp}{dz} = qE_z \Rightarrow \boxed{\frac{dE}{dz} = qE_z} \quad \left( \text{and also } \frac{dW}{dz} = qE_z \right) \quad W = E - E_0$$

rate of energy gain per unit length

$$\Rightarrow \Delta E = \int_{gap} \frac{dE}{dz} dz = \int_{gap} qE_z dz \Rightarrow \boxed{\Delta E = q\Delta V}$$

energy gain per electrode pair

# RF ACCELERATION: BUNCHED BEAM

We consider now the acceleration between two electrodes fed by an RF generator

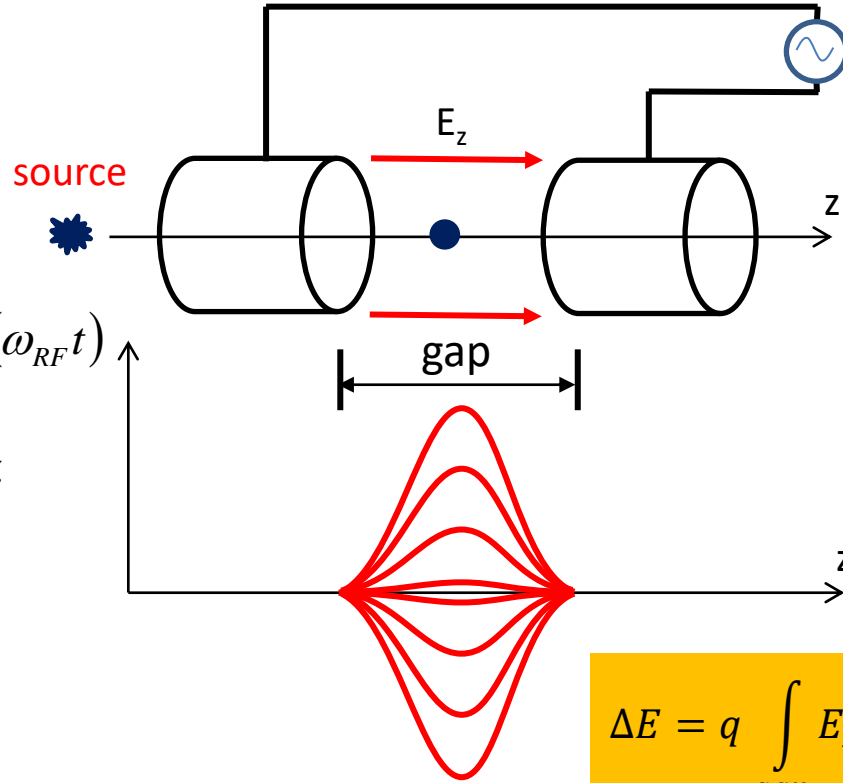

$$E_z(z, t) = E_{RF}(z) \cos(\omega_{RF} t)$$

$$V_{RF} = \int_{gap} E_{RF}(z) dz$$

$$\Delta V = V_{RF} \cos(\omega_{RF} t) \quad \omega_{RF} = 2\pi f_{RF} = \frac{2\pi}{T_{RF}}$$

$$\Rightarrow \Delta E = q \hat{V}_{acc} \cos(\omega_{RF} t_{inj})$$

Only these particles are accelerated

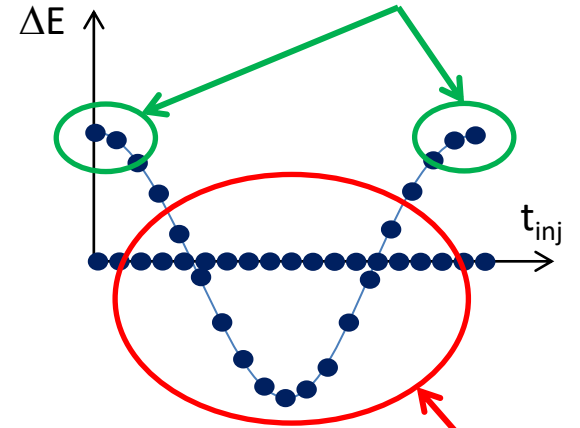

$$\Delta E = q \int_{gap} E_z(z, t) \Big|_{\substack{seen \\ by \\ particle}} dz = q \hat{V}_{acc} \cos(\phi_{inj})$$

These particles are not accelerated and basically are lost during the acceleration process

**DC acceleration**

**RF acceleration**

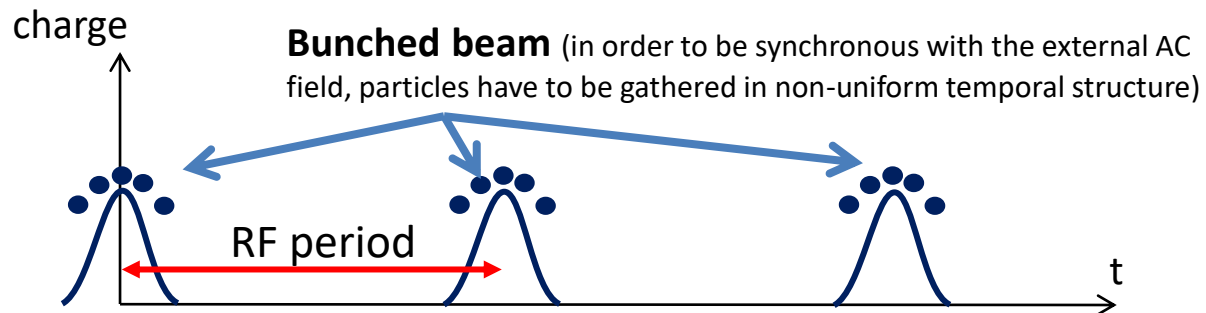
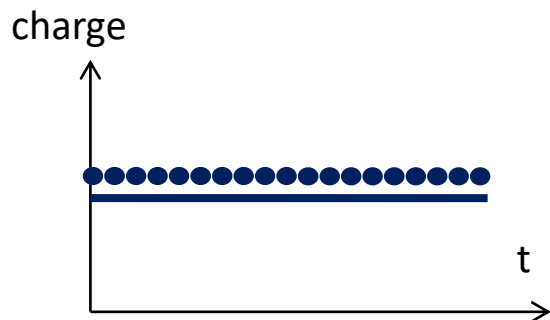

$\omega_{RF} t_{inj}$

# DRIFT TUBE LENGTH AND FIELD SYNCHRONIZATION

(protons and ions or electrons at extremely low energy)

If now we consider a DTL structure, we have that at each gap the maximum energy gain is  $\Delta E_n = qV_{acc}$  and the particle increase its velocity accordingly to the previous relativistic formulae. It is convenient to refer to the center of each gap as follows:

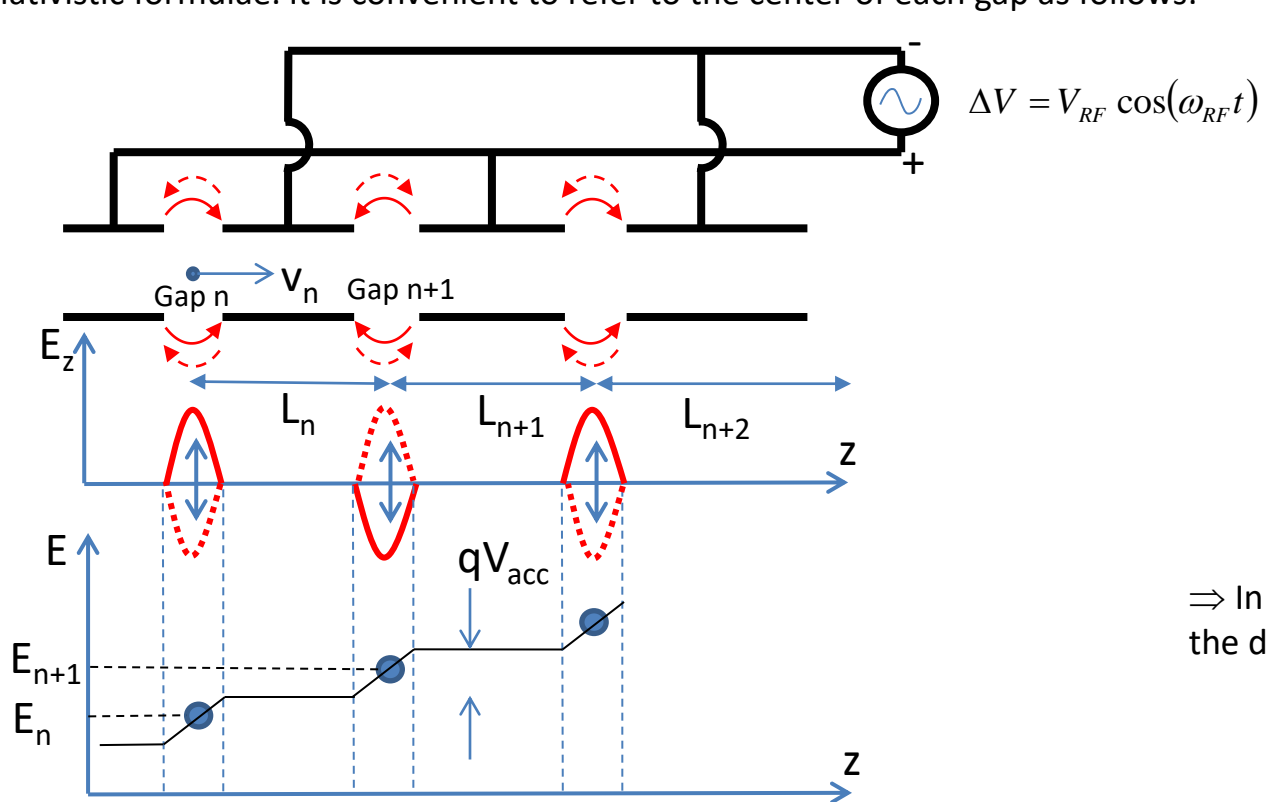

$$v_n = c\beta_n = c \sqrt{1 - \frac{1}{\gamma_n^2}} = c \sqrt{1 - \left(\frac{E_o}{E_n}\right)^2}$$

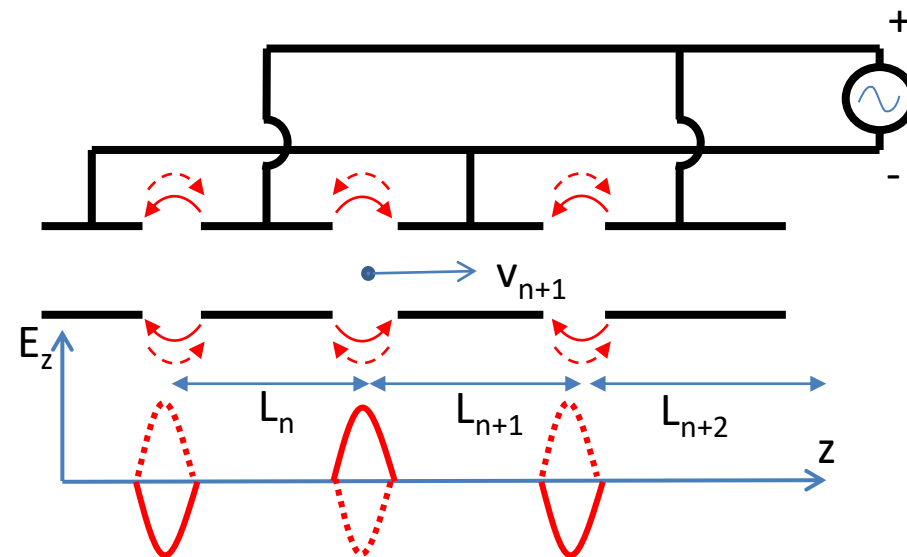
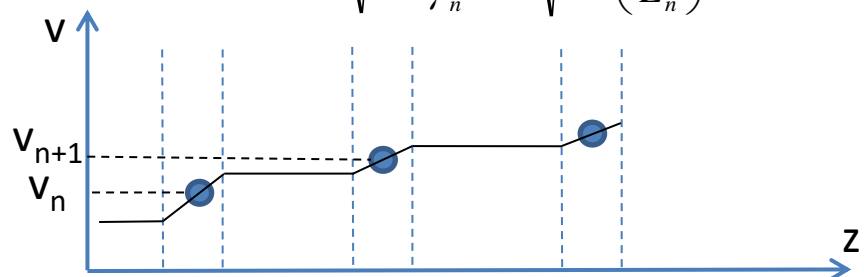

⇒ In order to be **synchronous with the accelerating field at the center of each gap**, the distance between the centers of the gaps ( $L_n$ ) has to be increased as:

$$t_n = \frac{L_n}{\bar{v}_n} = \frac{T_{RF}}{2} \Rightarrow L_n = \frac{1}{2} \bar{v}_n T_{RF} = \frac{1}{2} \bar{\beta}_n \underbrace{c T_{RF}}_{\lambda_{RF}} \Rightarrow L_n = \frac{1}{2} \bar{\beta}_n \lambda_{RF}$$

$\bar{v}_n$  = average particle velocity between the gap n and n+1

⇒ The **energy gain per unit length** (i.e. the **average accelerating gradient times q**) is given by:

$$\frac{\Delta E}{\Delta L} = \frac{qV_{acc}}{L_n} = \frac{2qV_{acc}}{\lambda_{RF} \bar{\beta}_n} \quad [\text{eV/m}]$$

# ACCELERATION WITH HIGH RF FREQUENCIES: RF CAVITIES

There are two important **consequences** of the previous obtained formulae:

$$L_n = \frac{1}{2} \bar{\beta}_n \lambda_{RF}$$



The condition  $L_n \ll \lambda_{RF}$  (necessary to model the tube as an **equipotential region**) requires  $\beta \ll 1$ .  $\Rightarrow$  The Wideröe technique can **not be applied to relativistic particles**.

$$\frac{\Delta E}{\Delta L} = \frac{qV_{acc}}{L_n} = qE_{acc} = \frac{2qV_{acc}}{\lambda_{RF} \bar{\beta}_n}$$



Moreover when particles get high velocities the drift spaces get longer and one loses on the efficiency. The **average accelerating gradient ( $E_{acc}$  [V/m]) increase pushes towards small  $\lambda_{RF}$**  (high frequencies).

High frequency, high power **sources** became available after the **2<sup>nd</sup> world war** pushed by **military** technology needs (such as **radar**). Moreover, the concept of equipotential DT can not be applied at small  $\lambda_{RF}$  and the **power lost by radiation is proportional to the RF frequency**.



As a consequence we must consider **accelerating structures different from drift tubes**.

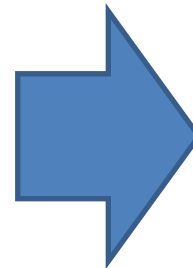

$\Rightarrow$  The solution consists of **enclosing the system in a cavity** which resonant frequency matches the RF generator frequency.

$\Rightarrow$  Each cavity can be independently powered from the RF generator

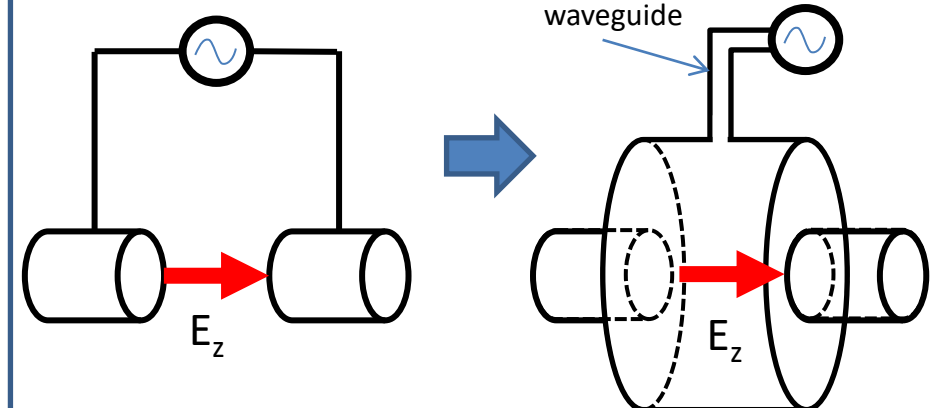

# RF CAVITIES

⇒ High frequency RF accelerating fields are confined in **cavities**.

⇒ The cavities are **metallic closed volumes** where the e.m fields has a particular spatial configuration (**resonant modes**) whose components, including the accelerating field  $E_z$ , oscillate at some specific frequencies  $f_{RF}$  (resonant frequency) characteristic of the mode.

⇒ The modes are excited by **RF generators** that are **coupled to the cavities** through waveguides, coaxial cables, etc...

⇒ The resonant modes are called **Standing Wave (SW) modes** (spatial fixed configuration, oscillating in time).

⇒ The spatial and temporal field profiles in a cavity have to be computed (analytically or numerically) **by solving the Maxwell equations** with the proper boundary conditions.

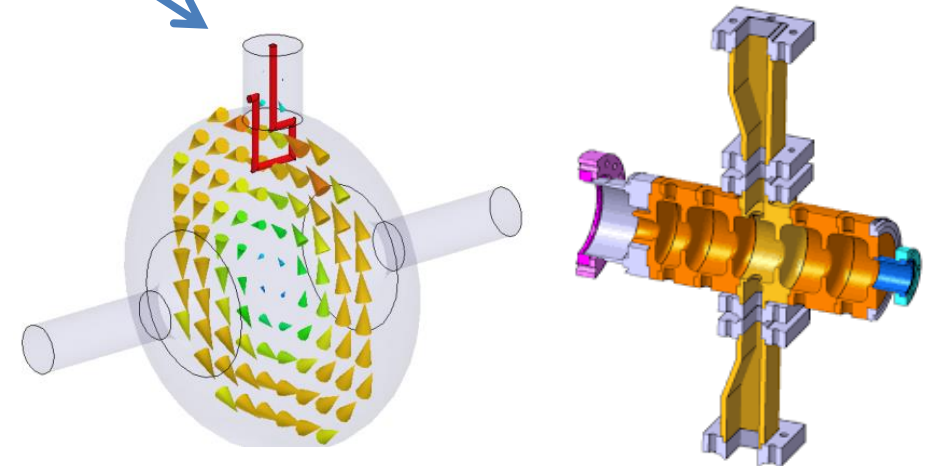
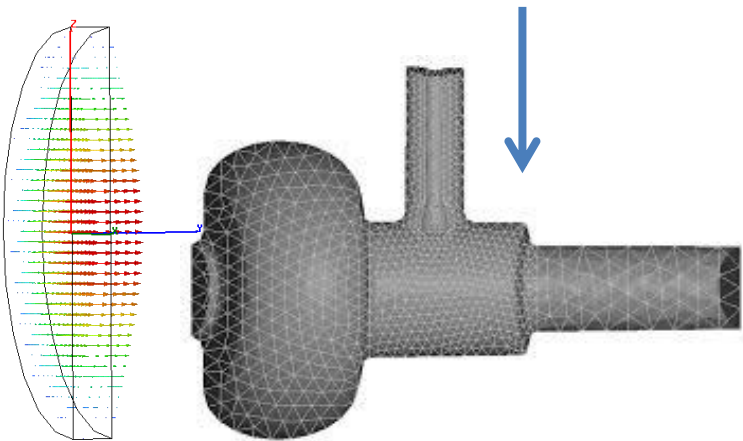
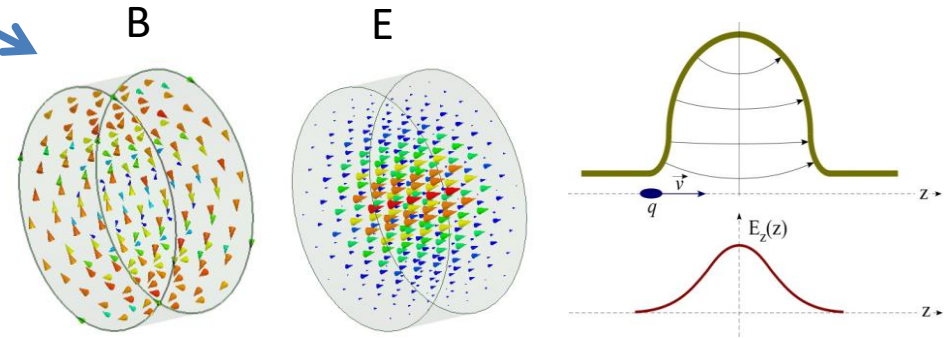

# ALVAREZ STRUCTURES

Alvarez's structure can be described as a special DTL in which the electrodes are part of a **resonant macrostructure**.

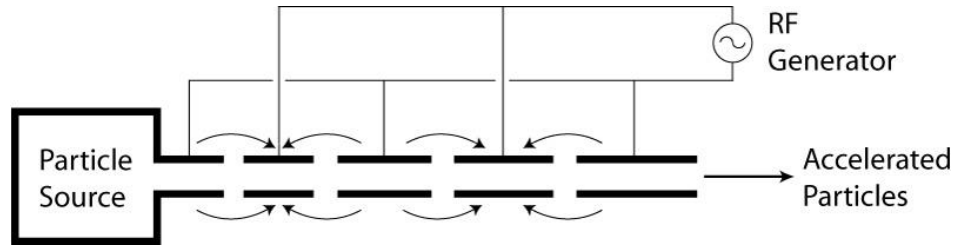

(protons and ions)

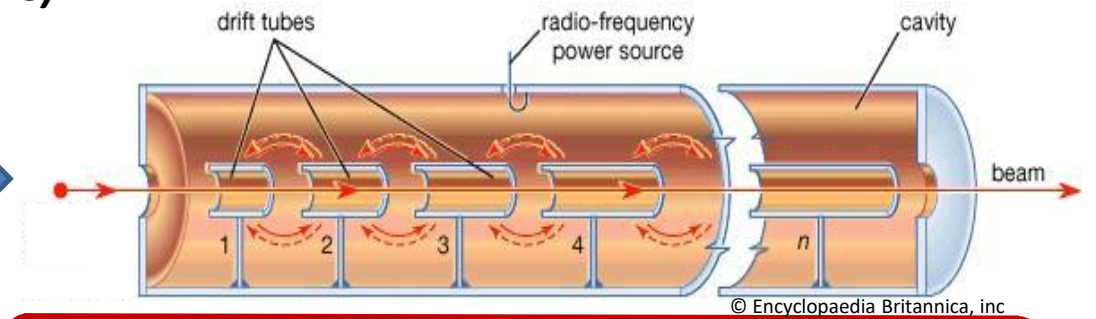

⇒The DTL operates in **0 mode** for **protons and ions** in the range  $\beta=0.05-0.5$   
 ( $f_{RF}=50-400$  MHz,  $\lambda_{RF}=6-0.7$  m) 1-100 MeV;

⇒The beam is inside the “**drift tubes**” when the electric field is decelerating. The **electric field** is concentrated between gaps;

⇒The drift tubes are suspended by **stems**;

⇒**Quadrupole** (for transverse focusing) can fit inside the drift tubes.

⇒In order to be synchronous with the accelerating field at each gap the **length of the n-th drift tube**  $L_n$  has to be:

$$L_n = \bar{\beta}_n \lambda_{RF}$$

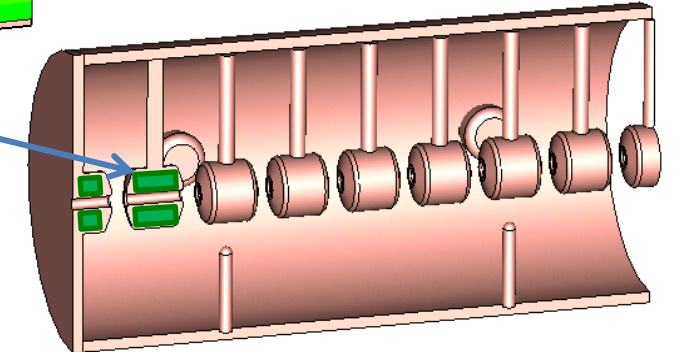
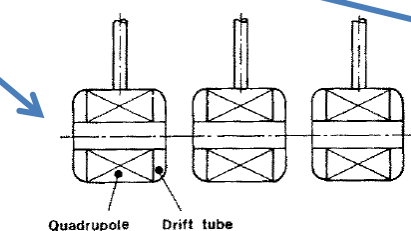
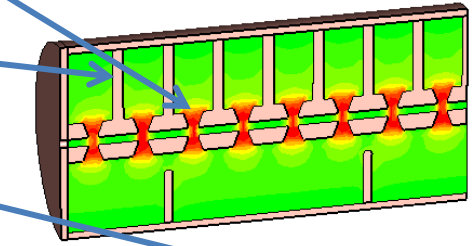
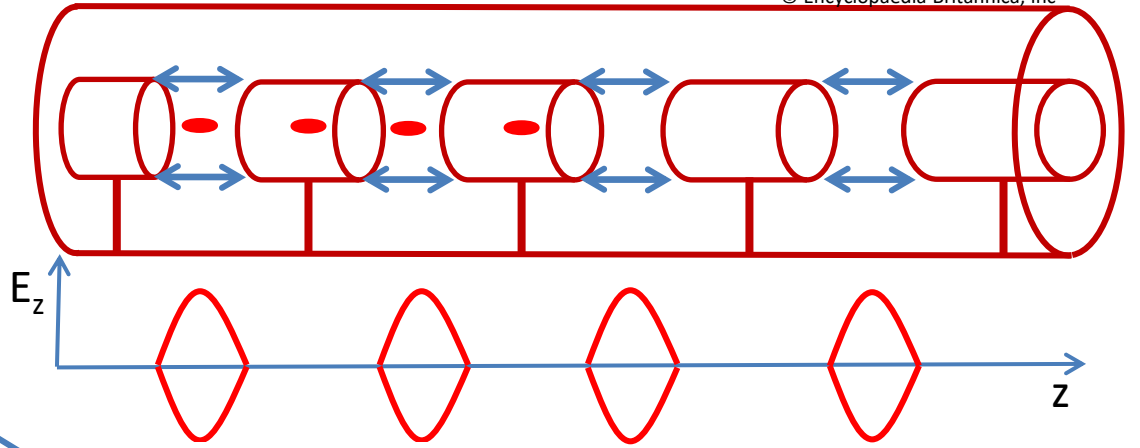

# ALVAREZ STRUCTURES: EXAMPLES

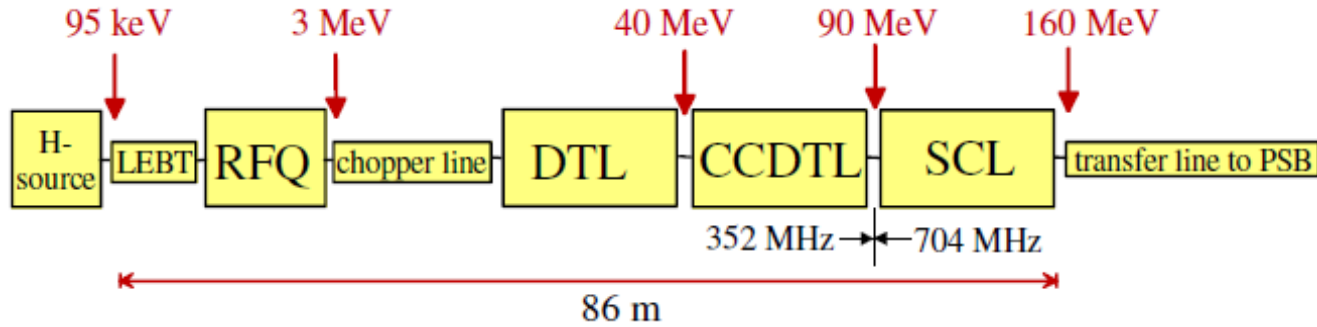

Ion species H-  
Output energy 160 MeV  
Bunch frequency 352.2 MHz  
Max. rep.-rate 2 Hz  
Beam pulse length 400 s  
Max. beam duty cycle 0.08%  
Linac current 40mA  
Average current 0.032mA

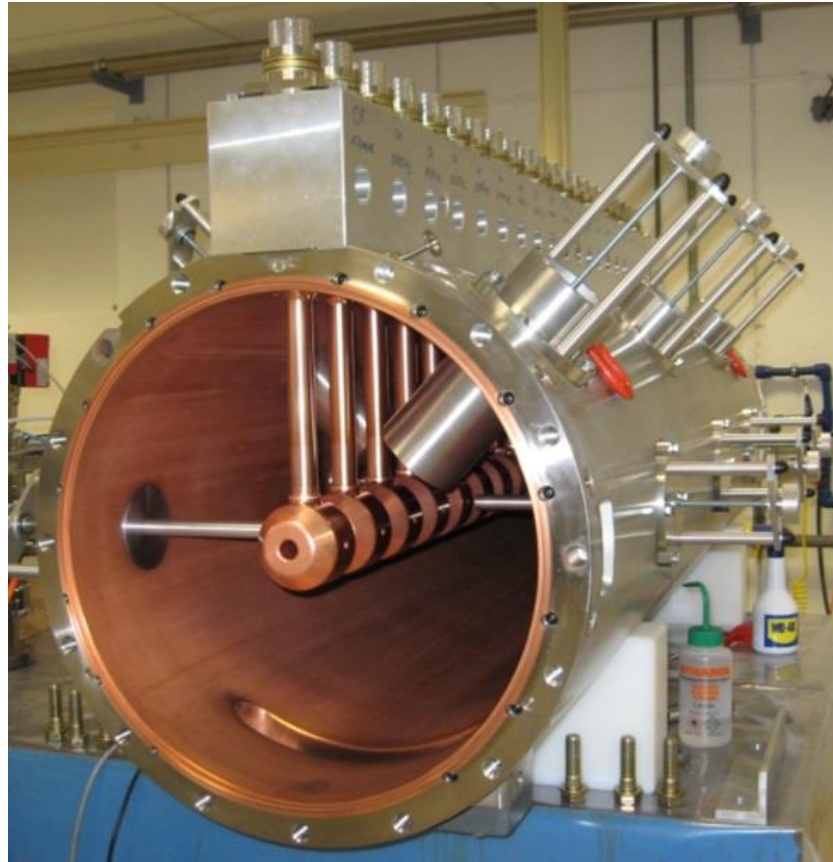

CERN LINAC 4: 352 MHz frequency, Tank diameter 500 mm, 3 resonators (tanks), Length 19 m, 120 Drift Tubes, Energy: 3 MeV to 40 MeV,  $\beta=0.08$  to 0.31  $\rightarrow$  cell length from 68mm to 264mm.

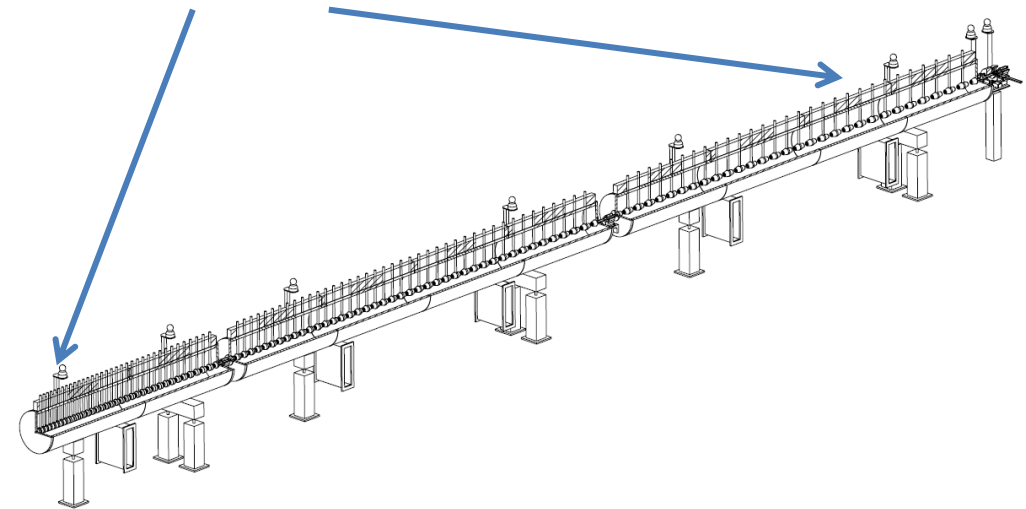



# HIGH $\beta$ CAVITIES: CYLINDRICAL STRUCTURES

(electrons or protons and ions at high energy)

⇒ When the  $\beta$  of the particles increases ( $>0.5$ ) one has to use **higher RF frequencies** ( $>400$ - $500$  MHz) to increase the accelerating gradient per unit length

⇒ the **DTL structures became less efficient** (effective accelerating voltage per unit length for a given RF power);



**Cylindrical single (or multiple cavities)** working on the **TM<sub>010</sub>-like mode** are used



For a **pure cylindrical structure** (also called **pillbox cavity**) the first accelerating mode (i.e. with non zero longitudinal electric field on axis) is the **TM<sub>010</sub> mode**. It has a well known analytical solution from Maxwell equation.

## Real cylindrical cavity

(TM<sub>010</sub>-like mode because of the shape and presence of beam tubes and couplers)

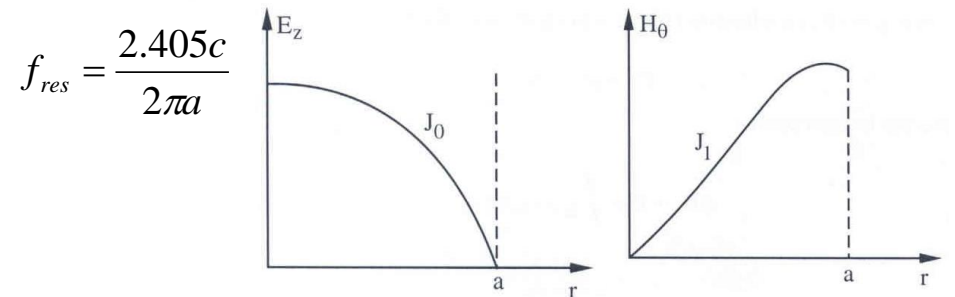
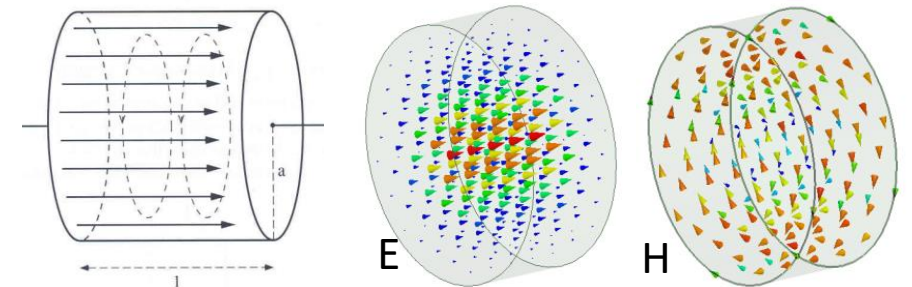
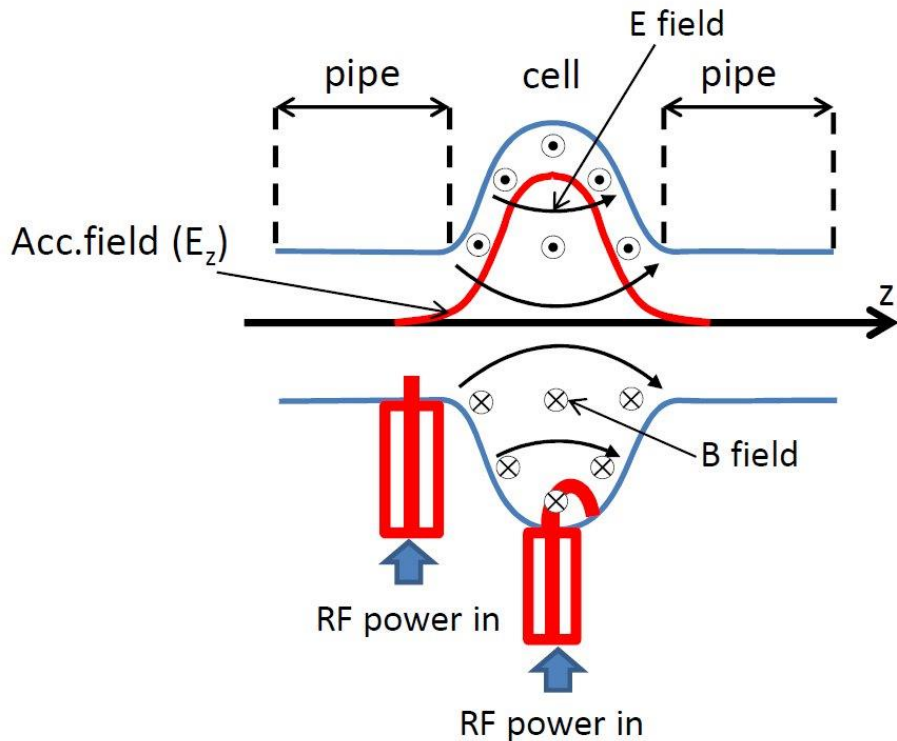

$$E_z = AJ_0\left(2.405\frac{r}{a}\right)\cos(\omega_{RF}t) \quad H_\theta = A\frac{1}{Z_0}J_1\left(2.405\frac{r}{a}\right)\sin(\omega_{RF}t)$$

# SW CAVITIES PARAMETERS: R, Q

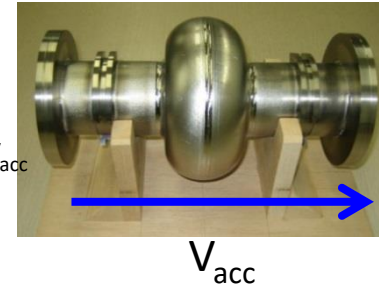
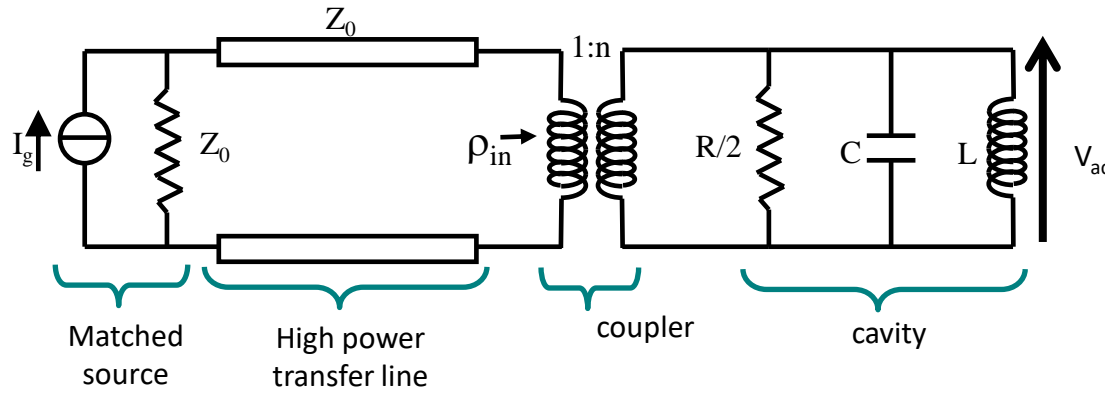
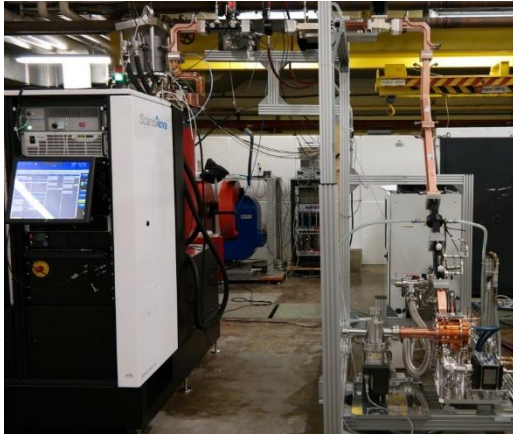

ACCELERATING VOLTAGE ( $V_{acc}$ )

DISSIPATED POWER ( $P_{diss}$ )

STORED ENERGY ( $W$ )

SHUNT IMPEDANCE

QUALITY FACTOR

The shunt impedance is the parameter that qualifies the **efficiency of an accelerating mode**. The higher is its value, the larger is the obtainable accelerating voltage for a given power. Traditionally, it is the quantity to optimize in order to **maximize the accelerating field for a given dissipated power**:

$$R = \frac{\hat{V}_{acc}^2}{P_{diss}} \quad [\Omega]$$

$$Q = \omega_{RF} \frac{W}{P_{diss}}$$

SHUNT IMPEDANCE PER UNIT LENGTH

$$r = \frac{(\hat{V}_{acc}/L)^2}{P_{diss}/L} = \frac{\hat{E}_{acc}^2}{P_{diss}} \quad [\Omega/m]$$

NC cavity  $Q \sim 10^4$   
SC cavity  $Q \sim 10^{10}$

NC cavity  $R \sim 1M\Omega$

SC cavity  $R \sim 1T\Omega$

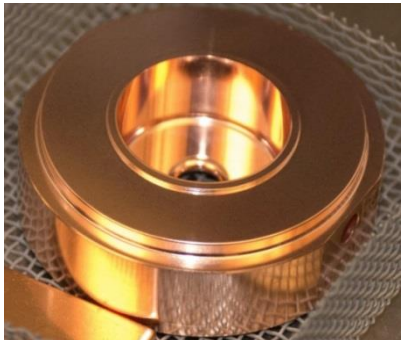

**Example:**

$R \sim 1M\Omega$

$P_{diss} = 1 \text{ MW}$

$V_{acc} = 1 \text{ MV}$

For a cavity working at 1 GHz with a structure length of 10 cm we have an average accelerating field of 10 MV/m

# MULTI-CELL SW CAVITIES

*(electrons or protons and ions at high energy)*

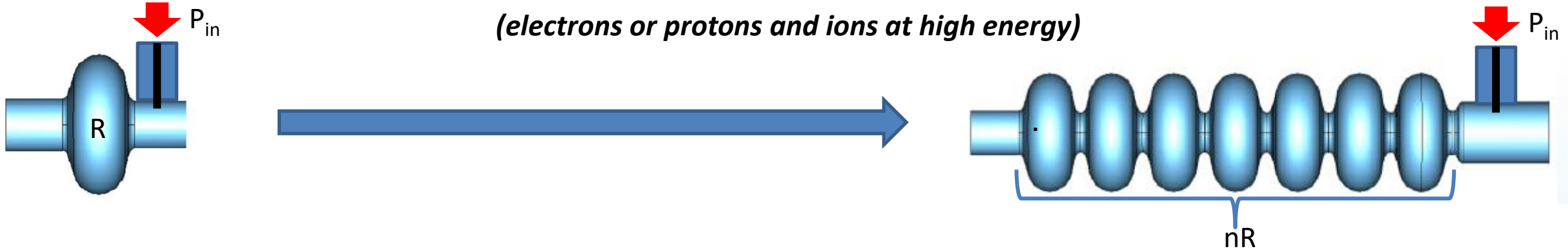

- In a multi-cell structure there is **one RF input coupler**. As a consequence the **total number of RF sources is reduced**, with a **simplification of the layout and reduction of the costs**;
- The **shunt impedance is  $n$  time** the impedance of a single cavity
- They are **more complicated** to fabricate than single cell cavities;
- The fields of adjacent cells couple through the cell **irises** and/or through properly designed coupling **slots**.

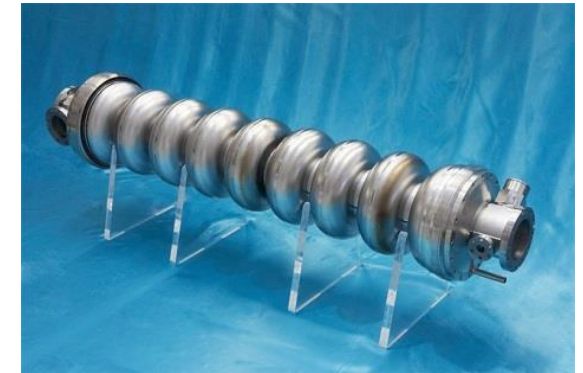

# MULTI-CELL SW CAVITIES: $\pi$ MODE STRUCTURES

(electrons or protons and ions at high energy)

- The N-cell structure behaves like a system composed by N coupled oscillators with N coupled multi-cell resonant modes.

- The modes are characterized by a cell-to-cell phase advance given by:

$$\Delta\phi_n = \frac{n\pi}{N-1} \quad n = 0, 1, \dots, N-1$$

- The multi cell mode generally used for acceleration is the  $\pi$ ,  $\pi/2$  and 0 mode (DTL as example operate in the 0 mode).

- The cell lengths have to be chosen in order to synchronize the accelerating field with the particle traveling into the structure at a certain velocity

EXAMPLE: 4 cell cavity operating on the  $\pi$ -mode

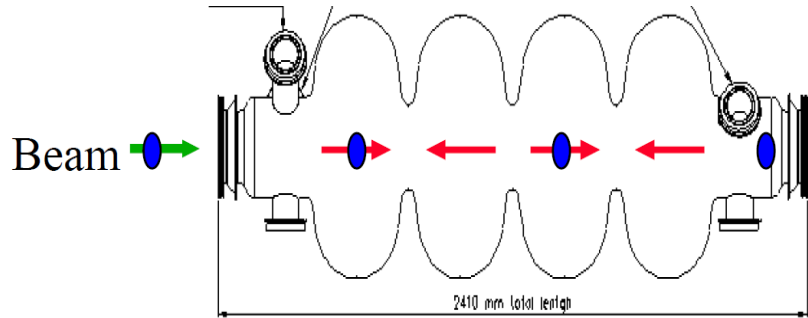

Electric field  
(at time  $t_0$ )

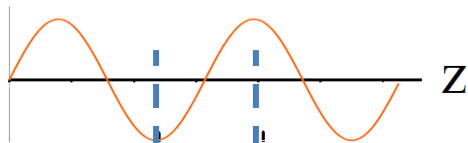

$$d = \frac{\beta c}{2f_{RF}} = \frac{\beta \lambda_{RF}}{2}$$

⇒ For **ions and protons** the cell lengths have to be increased along the linac that will be a sequence of different accelerating structures matched to the ion/proton velocity.

⇒ For **electron**,  $\beta=1$ ,  $d=\lambda_{RF}/2$  and the linac will be made of an injector followed by a series of identical accelerating structures, with cells all the same length.

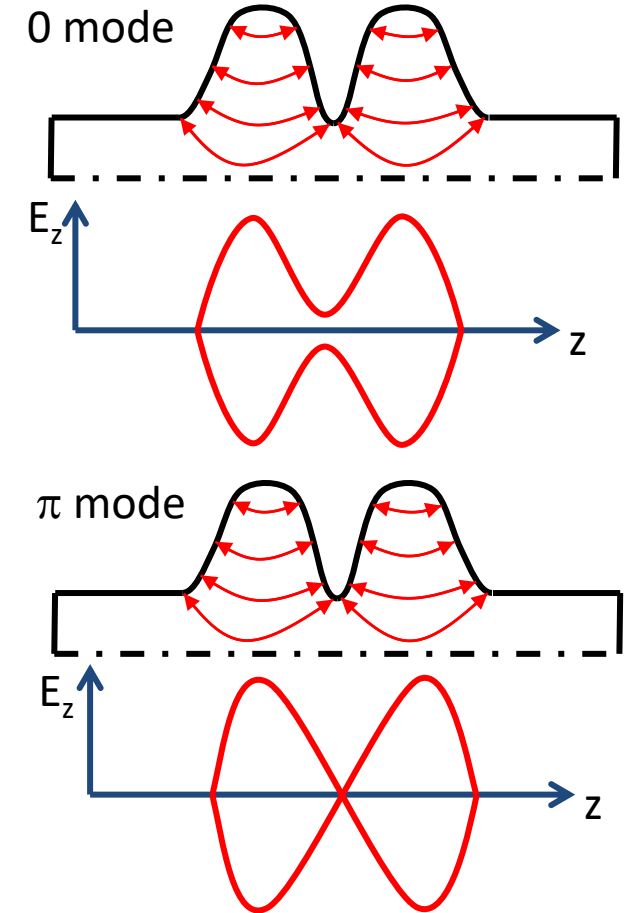

# $\pi$ MODE STRUCTURES: EXAMPLES

LINAC 4 (CERN) PIMS (PI Mode Structure) for protons:  $f_{RF}=352$  MHz,  $\beta>0.4$

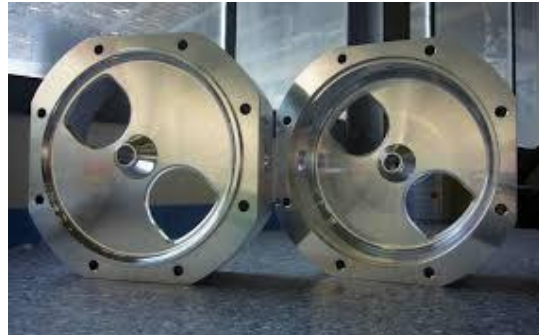
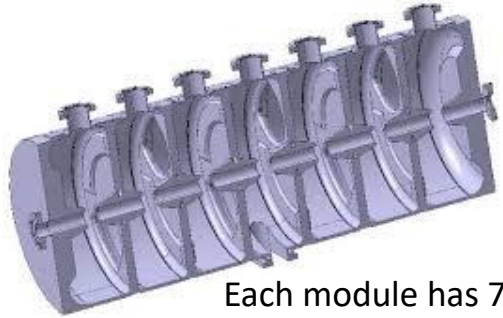
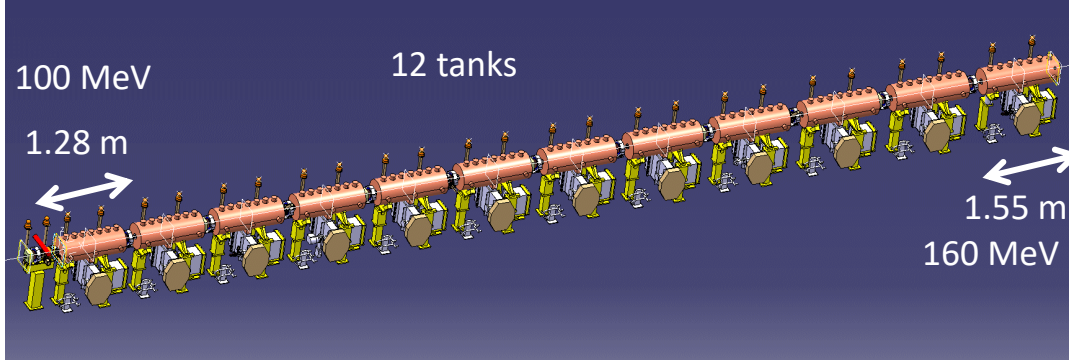

European XFEL (Desy): electrons

800 accelerating cavities

1.3 GHz / 23.6 MV/m

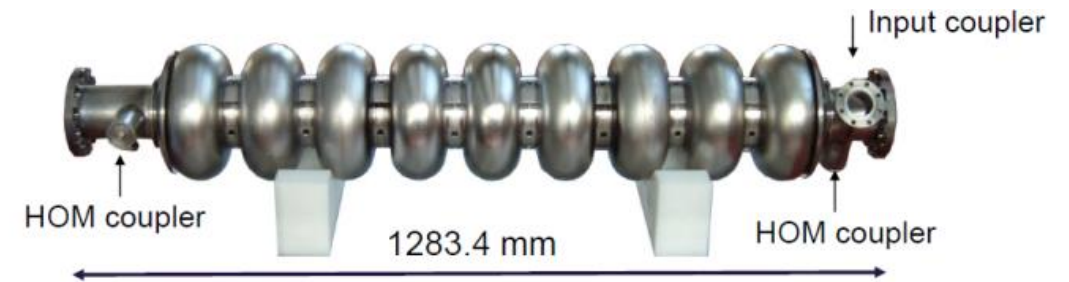

Cryomodule housing: 8 cavities, quadrupole and BPM

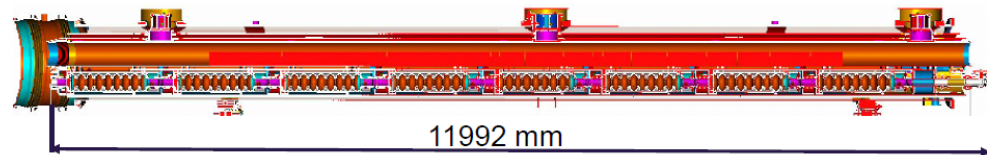

All identical  $\beta=1$   
Superconducting cavities

# MULTI-CELL SW CAVITIES: $\pi/2$ MODE STRUCTURES

*(electrons or protons and ions at high energy)*

⇒ It is possible to demonstrate that **over a certain number of cavities (>10)** working on the  $\pi$  mode, the **overlap between adjacent modes** can be a problem (as example the field uniformity due to machining errors is difficult to tune).

⇒ The criticality of a working mode depend on the **frequency separation between the working mode and the adjacent mode**

⇒ the  $\pi/2$  mode from this point of view is the **most stable mode**. For this mode it is possible to demonstrate that the accelerating field is zero every two cells. For this reason, the empty cells are put of axis and coupling slots are opened from the accelerating cells to the empty cells.

⇒ this allow to increase the number of cells to >20-30 without problems

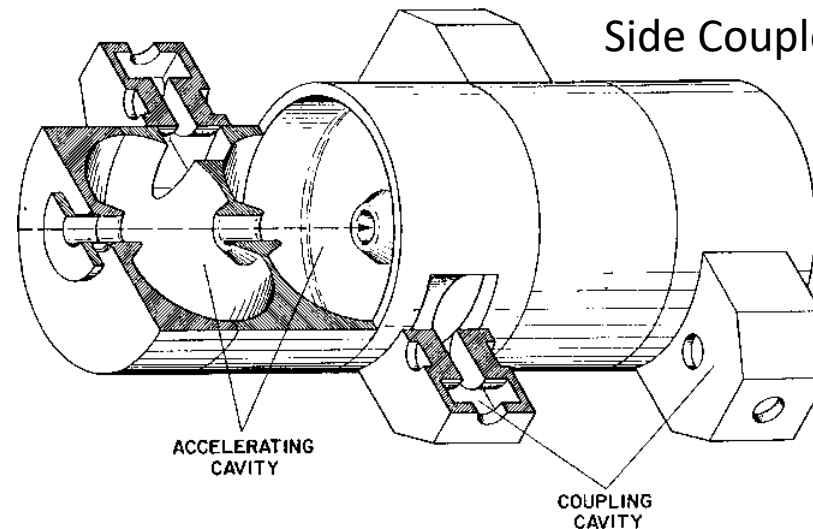
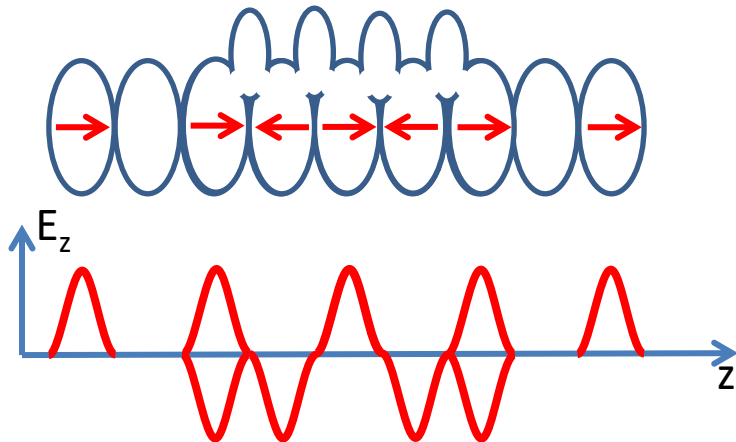
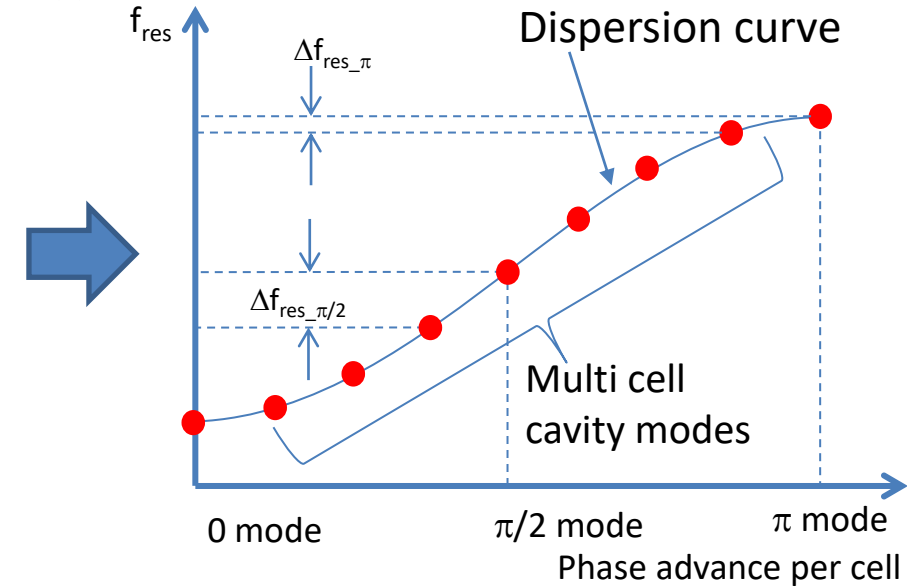

$f_{RF} = 800 - 3000$  MHz for proton ( $\beta = 0.5-1$ ) and electrons

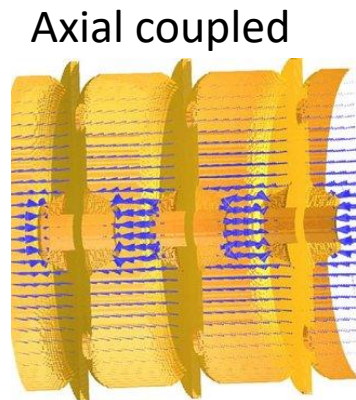

# TRAVELLING WAVE (TW) STRUCTURES

(electrons)

⇒ To accelerate charged particles, the electromagnetic field must have an **electric field along the direction of propagation of the particle**.

⇒ The field has to be synchronous with the particle velocity.

⇒ Up to now we have analyzed the standing **standing wave (SW)** structures in which the field has basically a given profile and oscillate in time (as example in DTL or **resonant cavities operating on the  $TM_{010}$ -like**).

$$E_z(z, t) = \underbrace{E_{RF}(z)}_{\text{field profile}} \underbrace{\cos(\omega_{RF} t)}_{\text{Time oscillation}}$$

⇒ There is another possibility to accelerate particles: using a **travelling wave (TW)** structure in which the RF wave is **co-propagating** with the beam with a **phase velocity equal to the beam velocity**.

⇒ Typically these structures **are used for electrons** because in this case the **phase velocity can be constant** all over the structure and equal to  $c$ . On the other hand it is difficult to modulate the phase velocity itself very quickly for a low  $\beta$  particle that changes its velocity during acceleration.

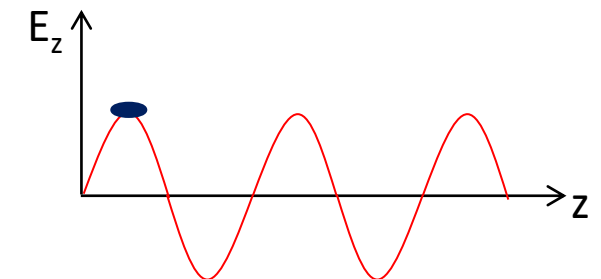
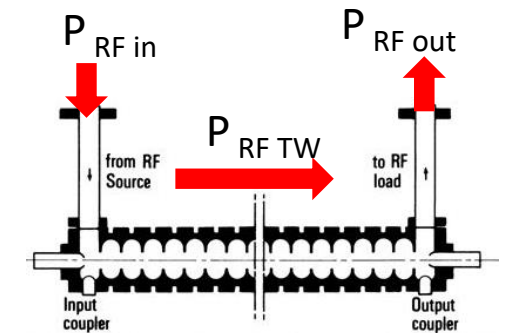
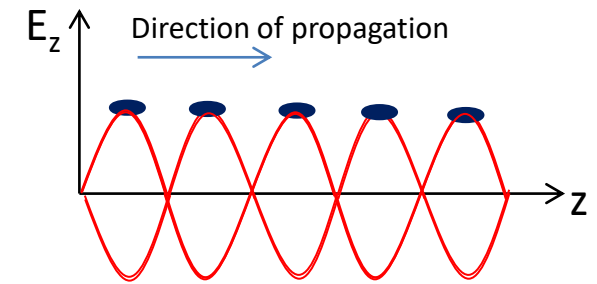
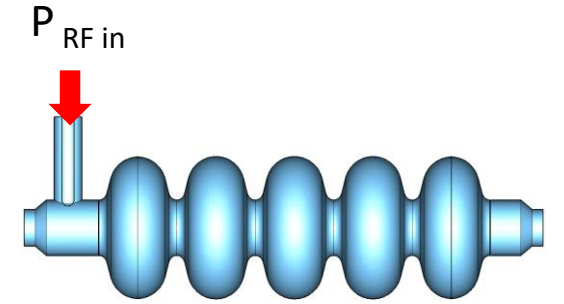

# TW CAVITIES: CIRCULAR WAVEGUIDE AND DISPERSION CURVE

(electrons)

In **TW structures** an e.m. wave with  $E_z \neq 0$  travel together with the beam in a special guide in which the **phase velocity of the wave matches the particle velocity ( $v$ )**. In this case the beam absorbs energy from the wave and it is **continuously accelerated**.

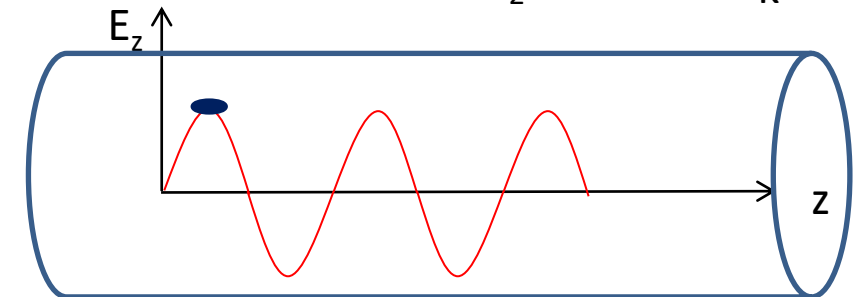
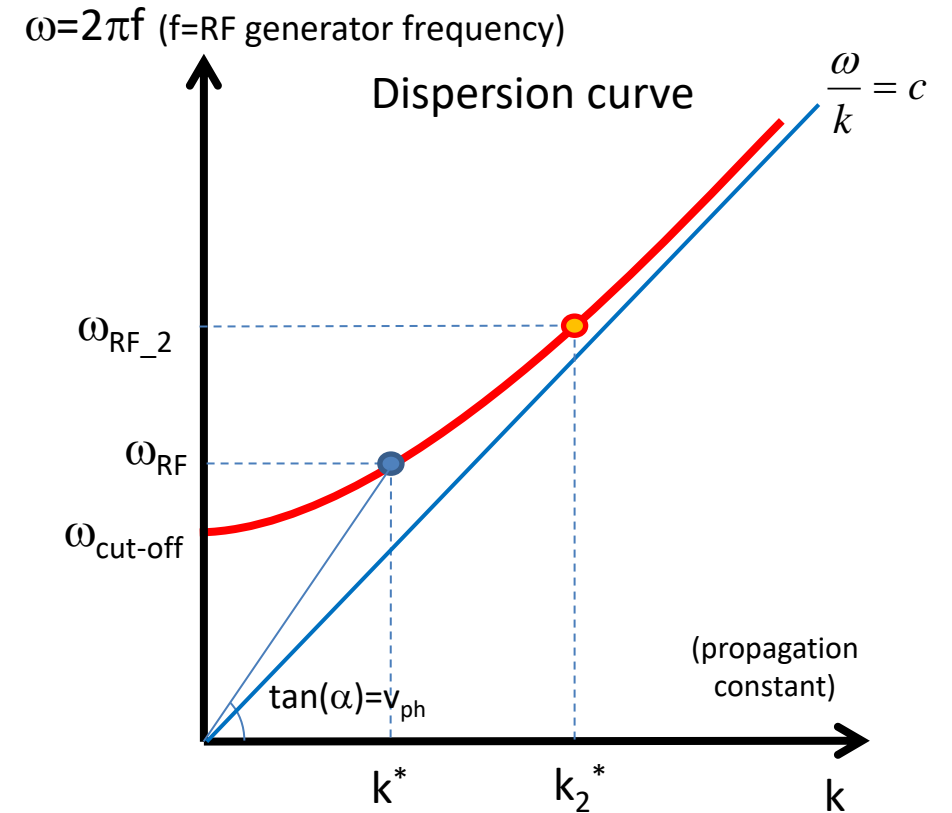
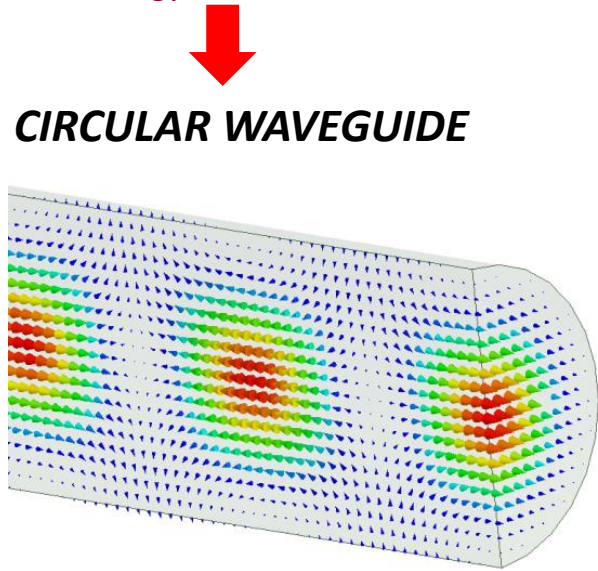

$$E_z|_{TM_{01}} = \underbrace{E_0(r)}_{J_0\left(\frac{p_{01}}{a}r\right)} \cos(\omega_{\text{RF}}t - k^*z) \quad \Rightarrow \quad v_{\text{ph}} = \frac{\omega_{\text{RF}}}{k^*} > c$$

As example if we consider a simple circular waveguide the first propagating mode with  $E_z \neq 0$  is the  $TM_{01}$  mode.

Nevertheless by solving the wave equation it turns out that an e.m. wave propagating in this **constant cross section waveguide** will **never be synchronous with a particle beam** since the **phase velocity is always larger than the speed of light  $c$** .



# TW CAVITIES: IRIS LOADED STRUCTURES

(electrons)

In order to slow-down the wave phase velocity, iris-loaded periodic structure have to be used.

CIRCULAR WAVEGUIDE

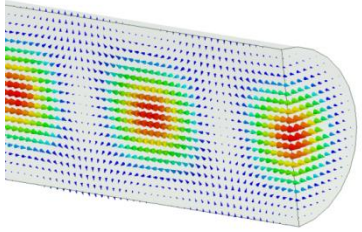

MODE  $TM_{01}$

IRIS LOADED STRUCTURE

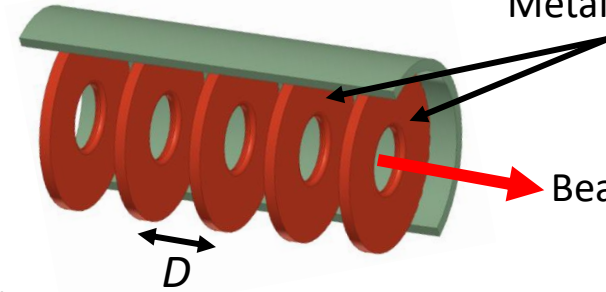

Metal irises

Beam direction

D

MODE  $TM_{01}$ -like

Periodic (in z) with period D  
(from Floquet theorem)

⇒The field in this type of structures is that of a special wave travelling within a spatial periodic profile.

$$E_z|_{TM_{01}} = E_0(r)\cos(\omega_{RF}t - k^*z)$$

$$E_z|_{TM_{01}\text{-like}} = \hat{E}_{acc}(r, z)\cos(\omega_{RF}t - k^*z)$$

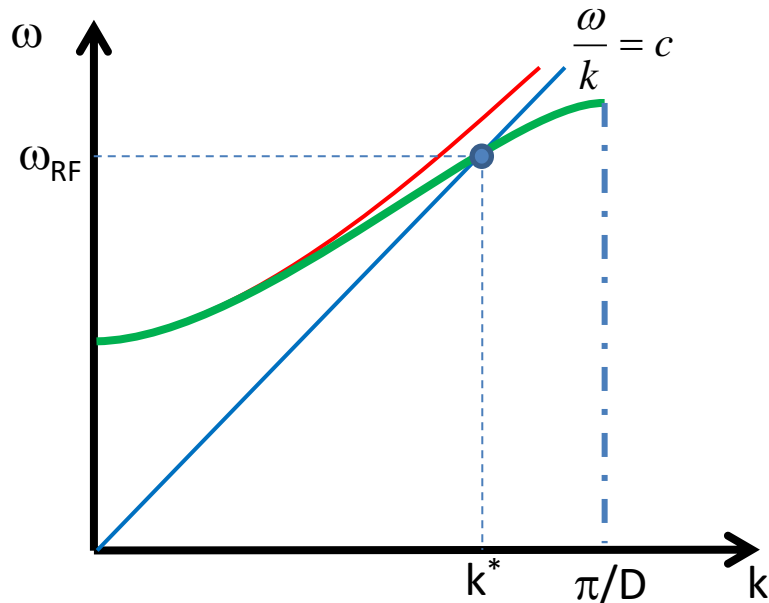

⇒The structure can be designed to have the **phase velocity equal to the speed of the particles**.

⇒This allows **acceleration over large distances** (few meters, hundred of cells) with just an input coupler and a relatively **simple geometry**.

⇒They are used **especially for electrons** (constant particle velocity→constant phase velocity, same distance between irises, easy realization)

# TW CAVITIES PARAMETERS: $r$ , $\alpha$ , $v_g$

Similarly to the SW cavities it is possible to define some figure of merit for the TW structures

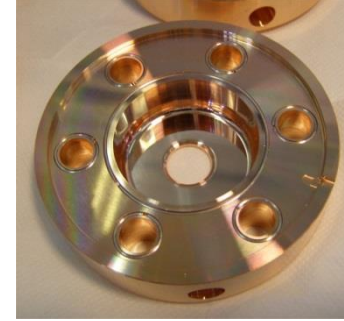
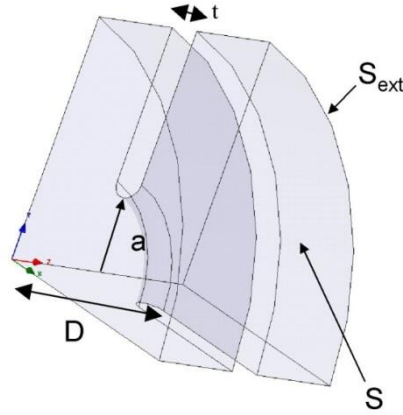
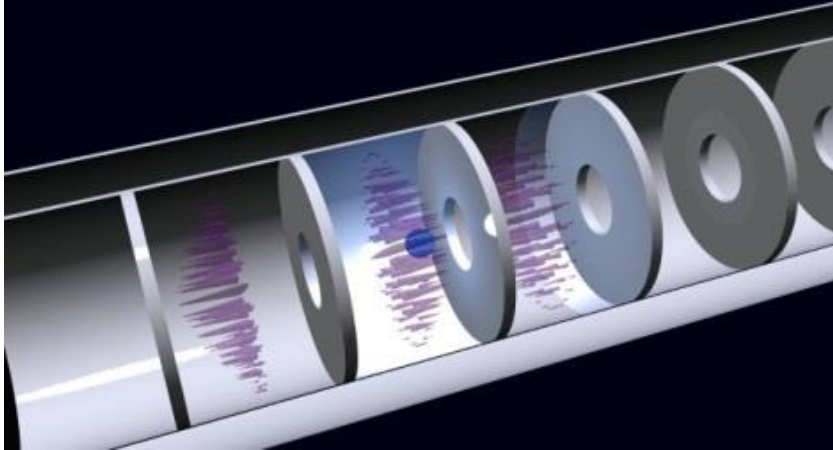

$$\hat{V}_{acc} = \left| \int_0^D \vec{E}_{acc} \cdot e^{j\omega_{RF} \frac{z}{c}} dz \right|$$

single cell accelerating voltage

$$\hat{E}_{acc} = \frac{\hat{V}_{acc}}{D}$$

average accelerating field in the cell

$$P_F = \int_{Section} \frac{1}{2} \text{Re}(\vec{E} \times \vec{H}^*) \cdot \hat{z} dS$$

flux power

$$P_{diss} = \frac{1}{2} R_s \int_{cavity\ wall} |\vec{H}_{tan}|^2 dS$$

average dissipated power in the cell

$$p_{diss} = \frac{P_{diss}}{D}$$

average dissipated power per unit length

$$W = \int_{cavity\ volume} \overbrace{\left( \frac{1}{4} \epsilon |\vec{E}|^2 + \frac{1}{4} \mu |\vec{H}|^2 \right)}^{\text{energy density}} dV$$

stored energy in the cell

$$w = \frac{W}{D}$$

average stored energy per unit length

$$r = \frac{\hat{E}_{acc}^2}{P_{diss}}$$

$$\alpha = \frac{P_{diss}}{2P_F}$$

$$v_g = \frac{P_F}{w}$$

$$Q = \omega_{RF} \frac{w}{P_{diss}}$$

$$\Delta\phi = kD$$

**Shunt impedance per unit length** [ $\Omega/m$ ]. Similarly to SW structures the higher is  $r$ , the higher the available accelerating field for a given RF power.

**Field attenuation constant** [1/m]: because of the wall dissipation, the RF power flux and the accelerating field decrease along the structure.

**Group velocity** [m/s]: the velocity of the energy flow in the structure ( $\sim 1-2\%$  of  $c$ ).

**Working mode** [rad]: defined as the phase advance over a period  $D$ . For several reasons the most common mode is the  $2\pi/3$

# TW CAVITIES: EQUIVALENT CIRCUIT AND FILLING TIME

(electrons)

In a TW structure, the **RF power enters** into the cavity through an **input coupler**, flows (travels) through the cavity in the same direction as the beam and an **output coupler at the end** of the structure is connected to a **matched power load**.

If there is no beam, the input power, reduced by the cavity losses, goes to the power load where it is dissipated.

In the presence of a large beam current, however, a fraction of the TW power is transferred to the beam.

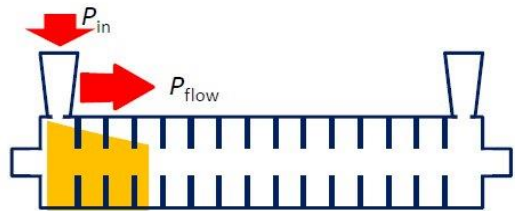
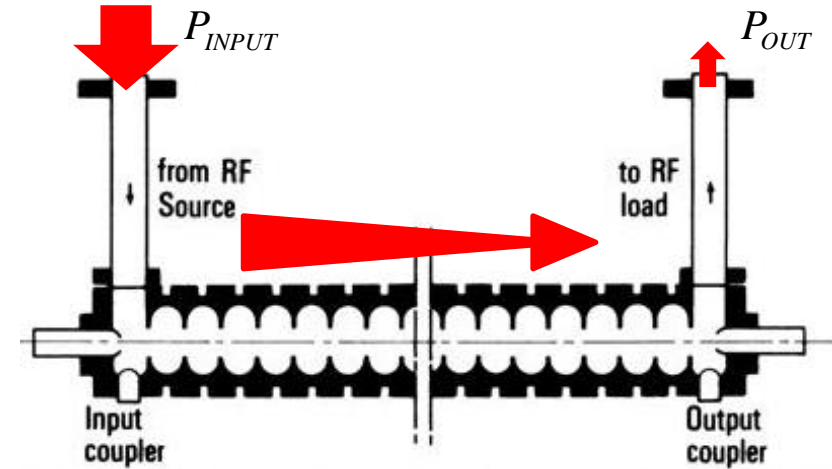

In a purely periodic structure, made by a sequence of **identical cells** (also called “**constant impedance structure**”),  $\alpha$  does not depend on  $z$  and both the RF power flux and the intensity of the accelerating field decay exponentially along the structure :

$$E_{acc}(z, t) = \underbrace{E_P(r, z)}_{\substack{\text{periodic function} \\ \text{with period } D}} \cos(\omega_{RF}t - k_z^* z) e^{-\alpha z} \approx E_{IN} \cos(\omega_{RF}t - k_z^* z) e^{-\alpha z}$$

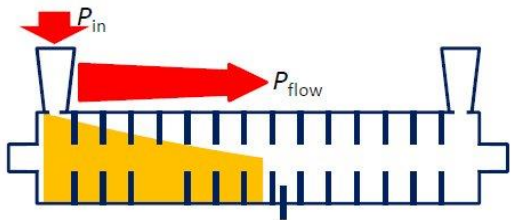

$$P_F(z) = P_{IN} e^{-2\alpha z} \quad P_{OUT} = P_{IN} e^{-2\alpha L} \quad E_{IN} = \sqrt{2\alpha r P_{IN}}$$

It is possible to demonstrate that, in order to keep the **accelerating field constant** along the structure, the **iris apertures have to decrease** along the structure.

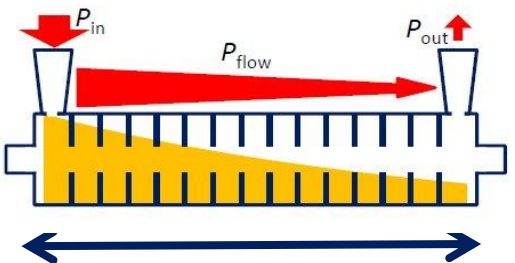

L

The **filling time** is the time necessary to propagate the RF wave-front from the input to the end of the section of length  $L$  is:

$$\tau_F = \frac{L}{v_g}$$

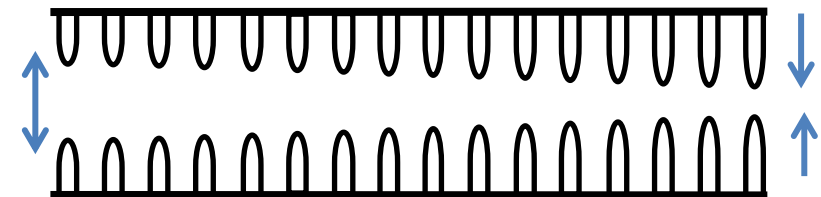

# LINAC TECHNOLOGY: MATERIALS



# ACCELERATING CAVITY TECHNOLOGY

⇒ The cavities (and the related LINAC technology) can be of different material:

- **copper** for normal conducting (NC, both SW than TW) cavities;
- **Niobium** for superconducting cavities (SC, SW);

⇒ We can choose between NC or the SC technology depending on the required performances in term of:

- **accelerating gradient** (MV/m);
- **RF pulse length** (how many bunches we can contemporary accelerate);
- **Duty cycle (see next slide)**: pulsed operation (i.e. 10-100 Hz) or continuous wave (CW) operation;
- **Average beam current**.
- ...

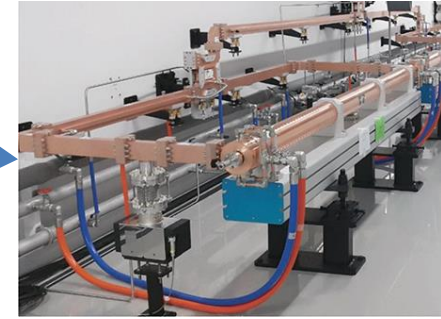

Dissipated power into the cavity walls is related to the surface currents

$$P_{diss} = \int_{\text{cavity wall}} \overbrace{\frac{1}{2} R_s H_{tan}^2}_{\text{power density}} dS$$

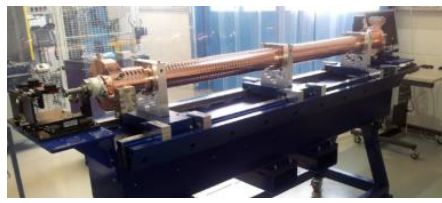
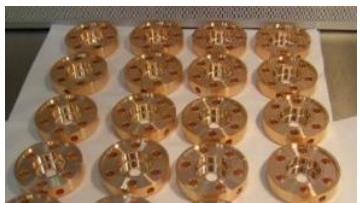
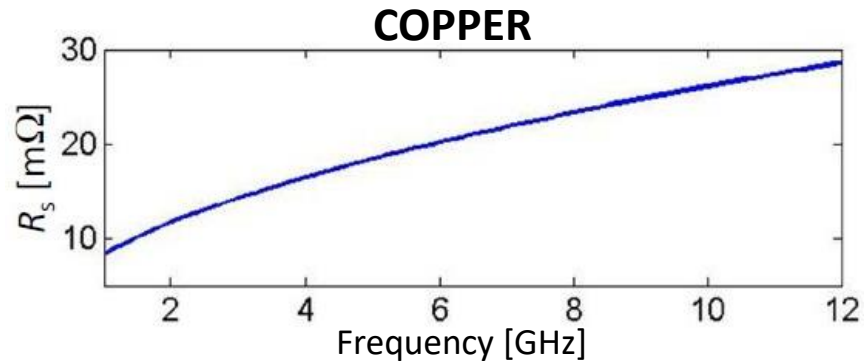

**NIOBIUM**  
Surface Resistance of Niobium  
at F = 700 MHz

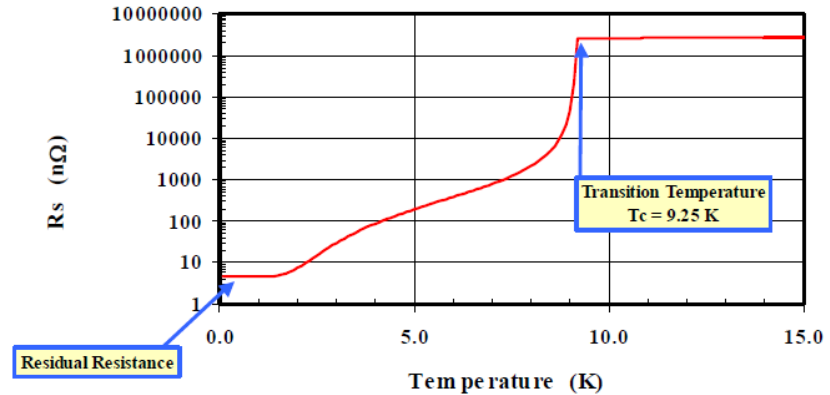

Between copper and Niobium there is a factor  $10^5$ - $10^6$



# RF STRUCTURE AND BEAM STRUCTURE: NC vs SC

The “**beam structure**” in a LINAC is directly related to the “**RF structure**”. There are two possible type of operations:

- **CW** (Continuous Wave) operation  $\Rightarrow$  allow, in principle, to operate with a continuous (bunched) beam
- **PULSED** operation  $\Rightarrow$  there are RF pulses at a certain repetition rate (**Duty Cycle (DC)=pulsed width/period**)

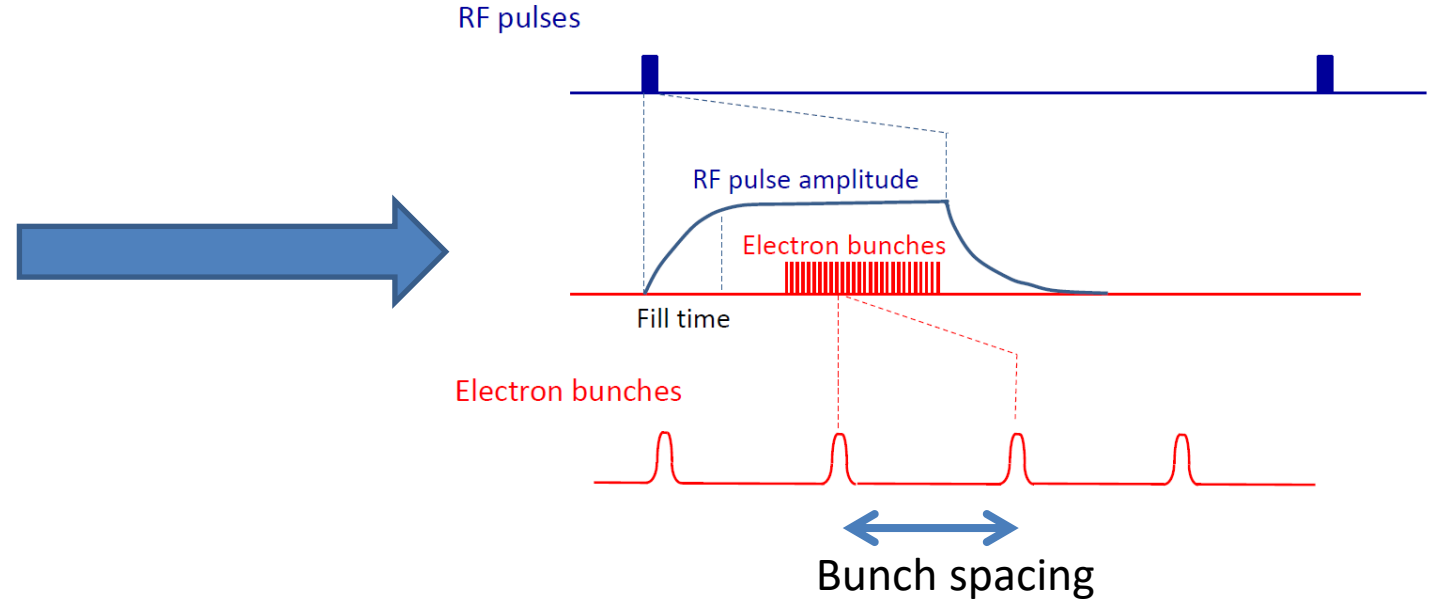
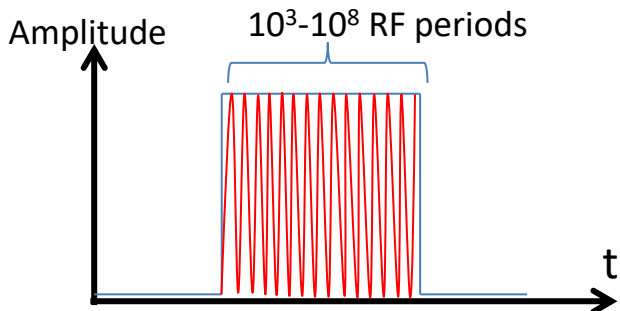
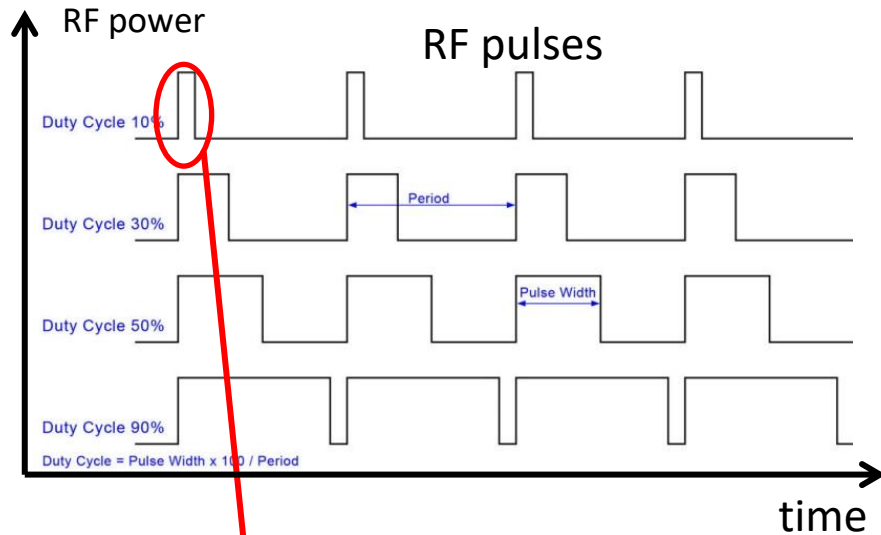

$\Rightarrow$  **SC structures allow operation at very high Duty Cycle (>1%) up to a CW operation (DC=100%)** (because of the extremely low dissipated power) **with relatively high gradient (>20 MV/m)**. This means that a continuous (bunched) beam can be accelerated.

$\Rightarrow$  **NC structures can operate in pulsed mode at very low DC (10<sup>-2</sup>-10<sup>-1</sup> %)** (because of the higher dissipated power) with, in principle, **larger peak accelerating gradient (>30 MV/m)**. This means that one or few tens of bunches can be, in general, accelerated. NB: NC structures can also operate in CW but at very low gradient because of the dissipated power.

# EXAMPLE: SWISSFEL LINAC (PSI)

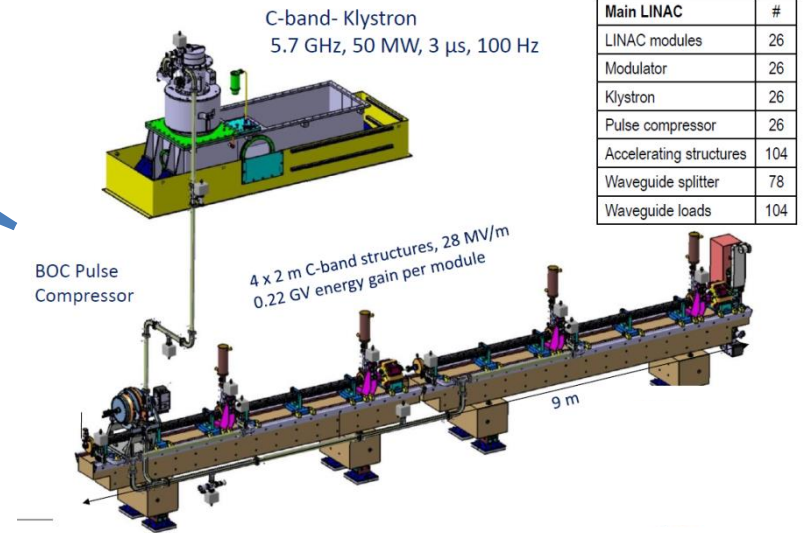
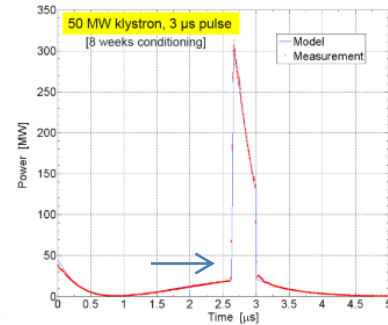
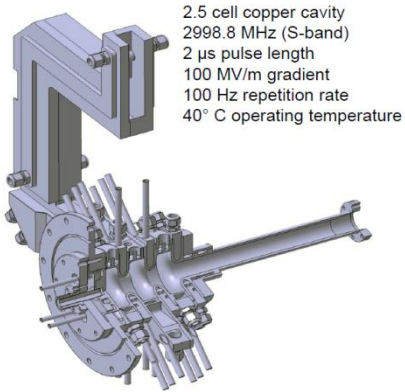
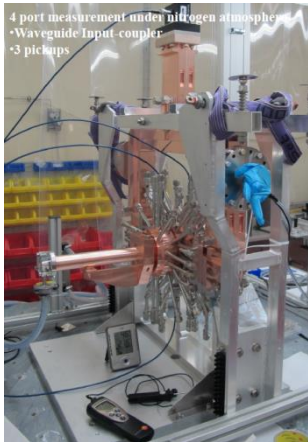
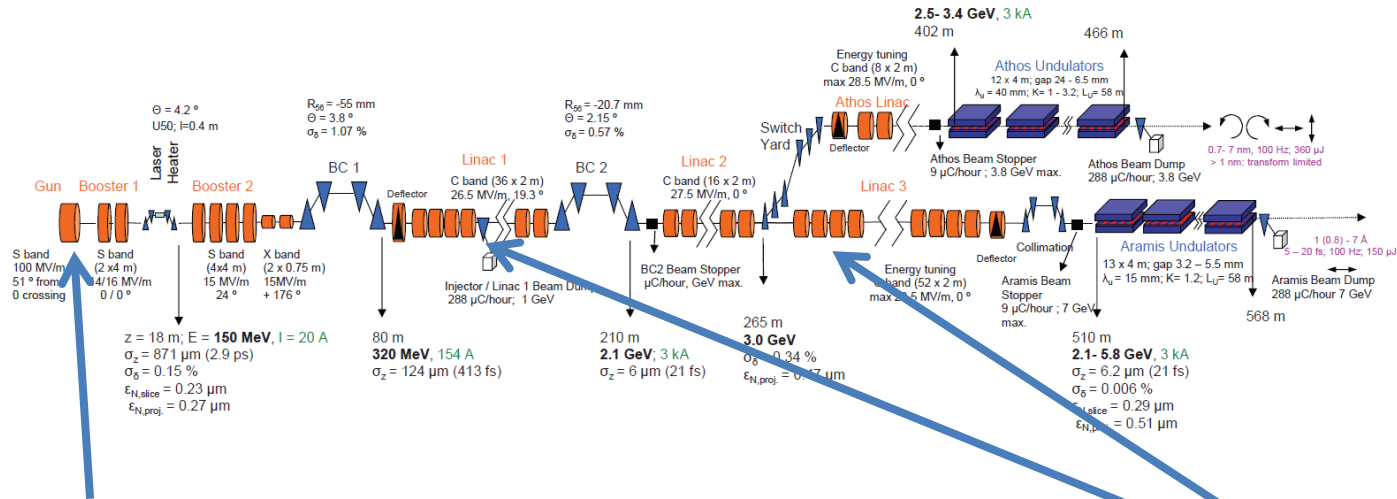

Main LINAC	#
LINAC modules	26
Modulator	26
Klystron	26
Pulse compressor	26
Accelerating structures	104
Waveguide splitter	78
Waveguide loads	104

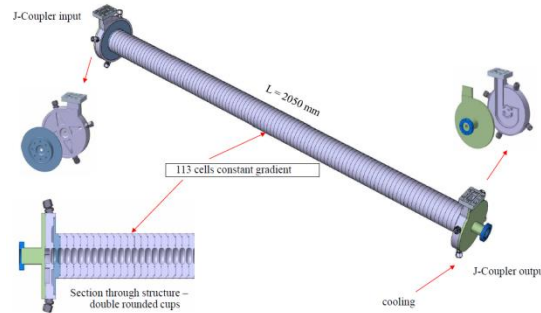

# EXAMPLES: EUROPEAN XFEL

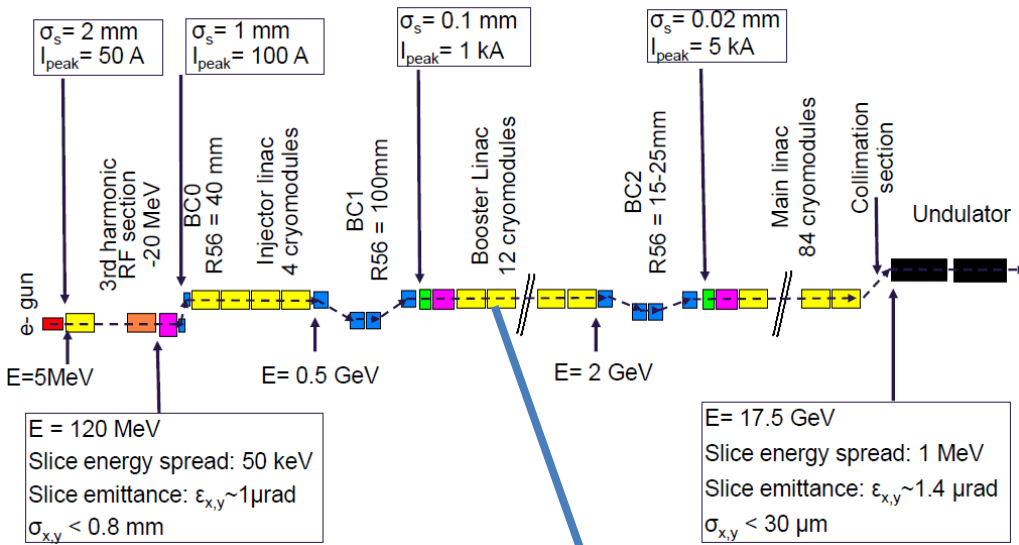

Nominal Energy	GeV	17.5
Beam pulse length	ms	0.60
Repetition rate	Hz	10
Max. # of bunches per pulse		2700
Min. bunch spacing	ns	220
Bunch charge	nC	1
Bunch length, $\sigma_z$	$\mu\text{m}$	< 20
Emittance (slice) at undulator	$\mu\text{rad}$	< 1.4
Energy spread (slice) at undulator	MeV	1

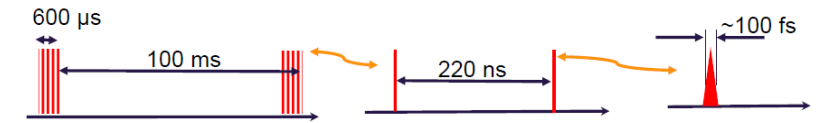

## 101 cryomodules in total

RF-system: 25 RF units. The unit = 4 cryomodules + RF-power source (klystron)

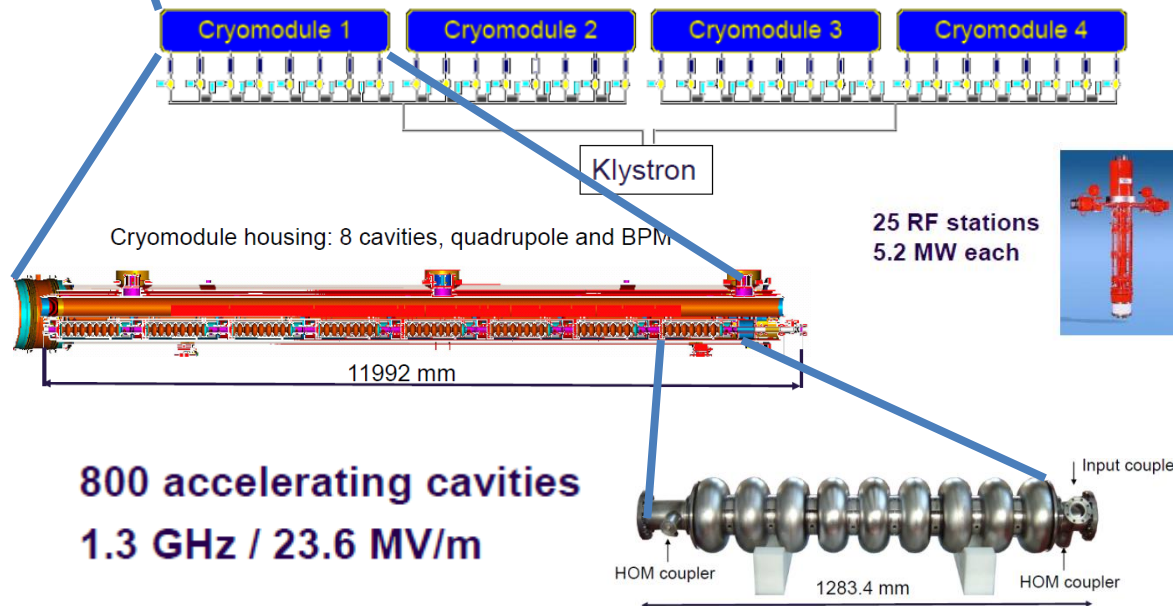



# LINAC: BASIC DEFINITION AND MAIN COMPONENTS

LINAC (linear accelerator) is a system that allows to accelerate charged particles through a linear trajectory by electromagnetic fields.

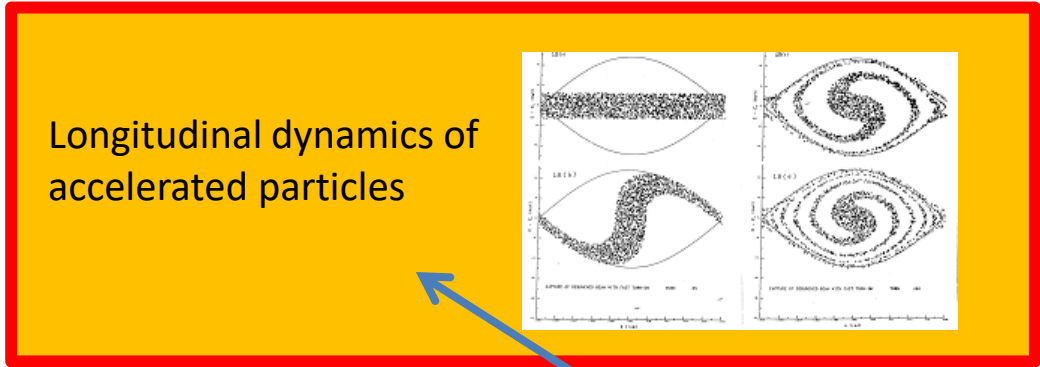

Transverse dynamics of accelerated particles

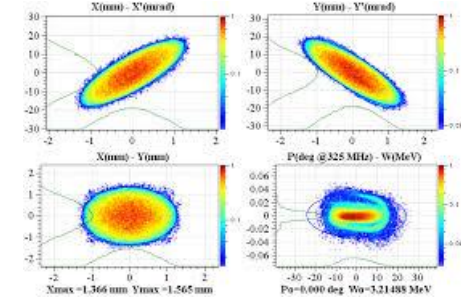

LINAC BEAM DYNAMICS

Particle source

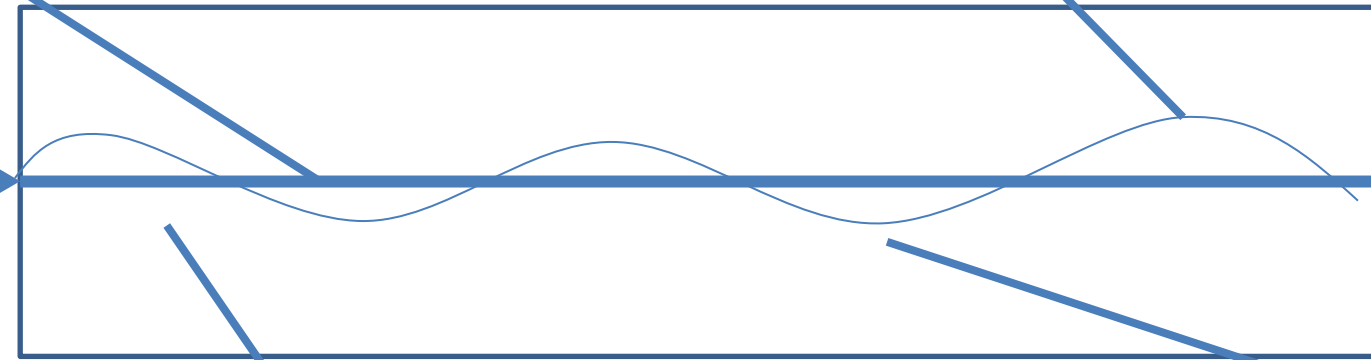
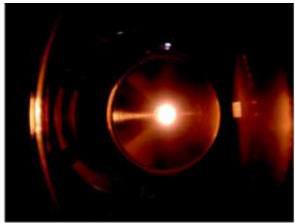

Accelerating structures



Focusing elements: quadrupoles and solenoids



LINAC COMPONENTS AND TECHNOLOGY

# SYNCHRONOUS PARTICLE/PHASE

⇒ Let us consider a **SW linac structure** made by accelerating **gaps** (like in DTL) or **cavities**.

⇒ In **each gap we have an accelerating field** oscillating in time and an integrated accelerating voltage ( $V_{acc}$ ) still oscillating in time than can be expressed as:

$$V_{acc} = \hat{V}_{acc} \cos(\omega_{RF} t)$$

⇒ Let's assume that the **“perfect” synchronism condition is fulfilled for a phase  $\phi_s$**  (called **synchronous phase**). This means that a particle (called **synchronous particle**) entering in a gap with a phase  $\phi_s$  ( $\phi_s = \omega_{RF} t_s$ ) with respect to the RF voltage receive an **energy gain** (and a consequent change in velocity) that allow entering in the subsequent gap with the **same phase  $\phi_s$**  and so on.

⇒ for this particle the energy gain in each gap is:

$$\Delta E = q \underbrace{\hat{V}_{acc} \cos(\phi_s)}_{V_{acc_s}} = q V_{acc_s}$$

⇒ obviously both  $\phi_s$  and  $\phi_s^*$  are synchronous phases.

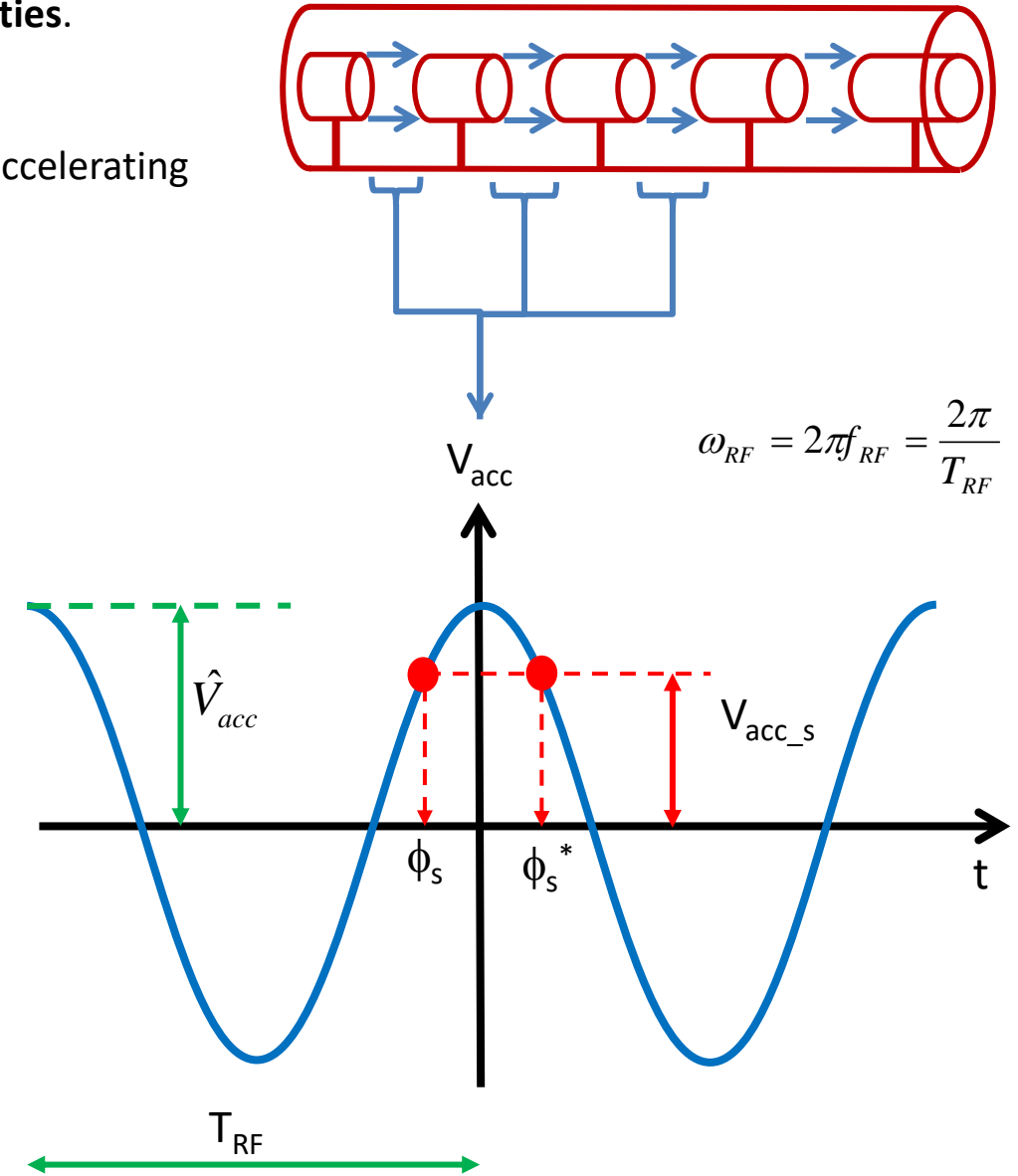

# PRINCIPLE OF PHASE STABILITY

*(protons and ions or electrons at extremely low energy)*

⇒ Let us consider now the first synchronous phase  $\phi_s$  (on the positive slope of the RF voltage). If we consider **another particle** “near” to the synchronous one **that arrives later in the gap** ( $t_1 > t_s$ ,  $\phi_1 > \phi_s$ ), it will see a higher voltage, it will gain a higher energy and a higher velocity with respect to the synchronous one. As a consequence its time of flight to next gap will be shorter, partially **compensating its initial delay**.

⇒ **Similarly** if we consider another particle “near” to the synchronous one that arrives before in the gap ( $t_1 < t_s$ ,  $\phi_1 < \phi_s$ ), it will see a smaller voltage, it will gain a smaller energy and a smaller velocity with respect to the synchronous one. As a consequence its time of flight to next gap will be longer, compensating the initial advantage.

⇒ **On the contrary** if we consider now the synchronous particle at phase  $\phi_s^*$  and another particle “near” to the synchronous one that arrives later or before in the gap, it will receive an energy gain that will increase further its distance from the synchronous one

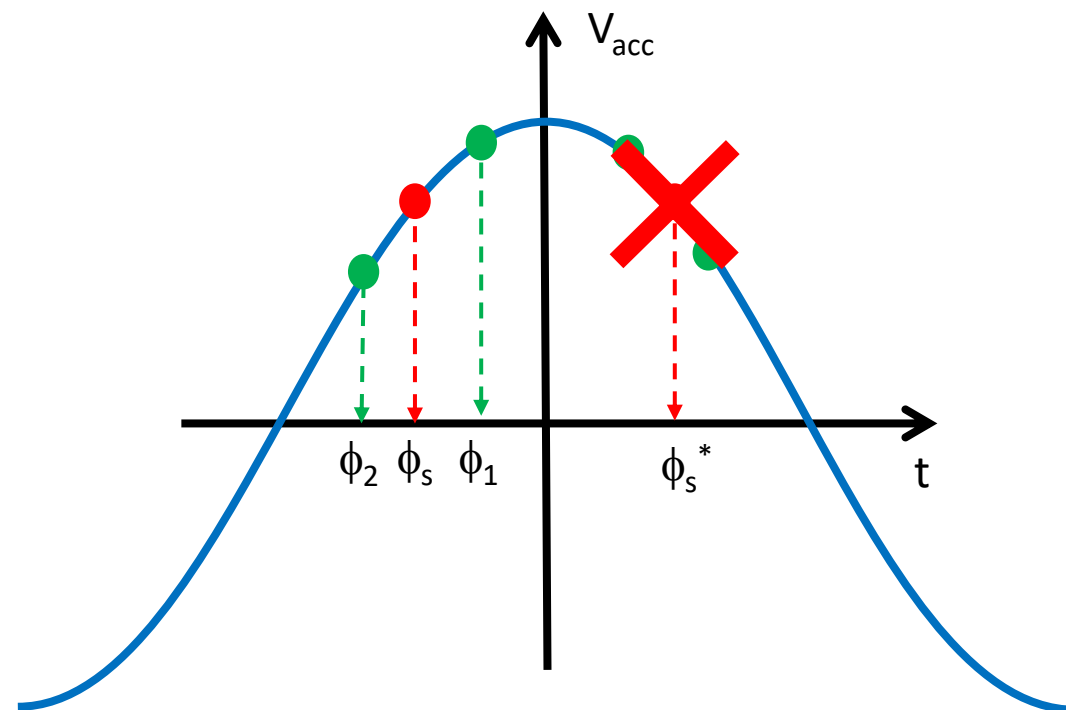

⇒ The choice of the synchronous phase in the positive slope of the RF voltage provides longitudinal focusing of the beam: **phase stability principle**.

⇒ The synchronous phase on the negative slope of the RF voltage is, on the contrary, **unstable**

⇒ Relying on particle velocity variations, **longitudinal focusing does not work for fully relativistic beams** (electrons). In this case acceleration “on crest” is more convenient.



# ENERGY-PHASE EQUATIONS (1/2)

(protons and ions or electrons at extremely low energy)

In order to study the **longitudinal dynamics in a LINAC**, the following variables are used, which describe the generic particle **phase** (time of arrival) and **energy with respect to the synchronous particle**:

Arrival time (phase) of a **generic particle** at a certain gap (or cavity)

Arrival time (phase) of the **synchronous particle** at a certain gap (or cavity)

$$\begin{cases} \varphi = \phi - \phi_s = \omega_{RF}(t - t_s) \\ w = E - E_s \end{cases}$$

Energy of a **generic particle** at a certain position along the linac

Energy of the **synchronous particle** at a certain position along the linac

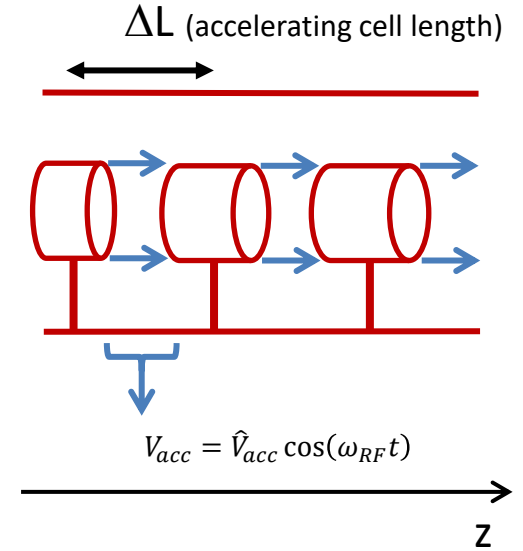

The **energy gain per cell (one gap + tube in case of a DTL)** of a generic particle and of a synchronous particle are:

$$\begin{cases} \Delta E_s = q\hat{V}_{acc} \cos \phi_s \\ \Delta E = q\hat{V}_{acc} \cos \phi = q\hat{V}_{acc} \cos(\phi_s + \varphi) \end{cases}$$

Dividing by the accelerating cell length  $\Delta L$  and assuming that:

$$\frac{\hat{V}_{acc}}{\Delta L} = \hat{E}_{acc}$$

Average accelerating field over the cell (i.e. **average accelerating field**)

subtracting

$$\Delta w = \Delta E - \Delta E_s = q\hat{V}_{acc} [\cos(\phi_s + \varphi) - \cos \phi_s]$$

$$\frac{\Delta w}{\Delta L} = q\hat{E}_{acc} [\cos(\phi_s + \varphi) - \cos \phi_s]$$

Approximating

$$\frac{\Delta w}{\Delta L} \approx \frac{dw}{dz}$$

$$\frac{dw}{dz} = q\hat{E}_{acc} [\cos(\phi_s + \varphi) - \cos \phi_s]$$

# ENERGY-PHASE EQUATIONS (2/2)

(protons and ions or electrons at extremely low energy)

On the other hand we have that the **phase variation per cell** of a generic particle and of a synchronous particle are:

$$\begin{cases} \Delta\phi_s = \omega_{RF}\Delta t_s \\ \Delta\phi = \omega_{RF}\Delta t \end{cases}$$

$\Delta t$  is basically the **time of flight** between two accelerating cells

$v, v_s$  are the average particles velocities

subtracting 

$$\Delta\phi = \omega_{RF}(\Delta t - \Delta t_s)$$

Dividing by the accelerating cell length  $\Delta L$  

$$\frac{\Delta\phi}{\Delta L} = \omega_{RF} \left( \frac{\Delta t}{\Delta L} - \frac{\Delta t_s}{\Delta L} \right) = \omega_{RF} \left( \frac{1}{v} - \frac{1}{v_s} \right) \stackrel{\text{MAT}}{\approx} - \frac{\omega_{RF}}{cE_0\beta_s^3\gamma_s^3} W$$

Approximating

$$\frac{\Delta\phi}{\Delta L} \cong \frac{d\phi}{dz}$$

This system of coupled (non linear) differential equations **describe the motion of a non synchronous particles** in the longitudinal plane with respect to the synchronous one.

$$\frac{dw}{dz} = q\hat{E}_{acc}[\cos(\phi_s + \phi) - \cos\phi_s]$$

$$\frac{d\phi}{dz} = - \frac{\omega_{RF}}{cE_0\beta_s^3\gamma_s^3} W$$

**MAT**

$$\omega_{RF} \left( \frac{1}{v} - \frac{1}{v_s} \right) = \omega_{RF} \left( \frac{v_s - v}{vv_s} \right) \stackrel{\text{MAT}}{\approx} - \frac{\omega_{RF}}{v_s^2} \Delta v = - \frac{\omega_{RF}}{c} \frac{\Delta\beta}{\beta_s^2} \quad \text{remembering that } \beta = \sqrt{1 - 1/\gamma^2} \Rightarrow \beta d\beta = d\gamma/\gamma^3 \Rightarrow - \frac{\omega_{RF}}{c} \frac{\Delta\beta}{\beta_s^2} \cong - \frac{\omega_{RF}}{c} \frac{\Delta\gamma}{\beta_s^3\gamma_s^3} = - \frac{\omega_{RF}}{c} \frac{\overline{\Delta E}}{E_0\beta_s^3\gamma_s^3}$$

# SMALL AMPLITUDE ENERGY-PHASE OSCILLATIONS

(protons and ions or electrons at extremely low energy)

$$\frac{dw}{dz} = q\hat{E}_{acc}[\cos(\phi_s + \varphi) - \cos \phi_s]$$

$$\frac{d\varphi}{dz} = -\frac{\omega_{RF}}{cE_0\beta_s^3\gamma_s^3}w \rightarrow cE_0\beta_s^3\gamma_s^3 \frac{d\varphi}{dz} = -\omega_{RF}w$$

Deriving both terms with respect to z

$$cE_0\beta_s^3\gamma_s^3 \frac{d^2\varphi}{dz^2} + cE_0 \frac{d\beta_s^3\gamma_s^3}{dz} \frac{d\varphi}{dz} = -\omega_{RF} \frac{dw}{dz}$$

$$\frac{d^2\varphi}{dz^2} + q \frac{\omega_{RF}\hat{E}_{acc} \sin(-\phi_s)}{cE_0\beta_s^3\gamma_s^3} \varphi = 0$$

General non linear differential equation that gives the phase evolution

$$cE_0\beta_s^3\gamma_s^3 \frac{d^2\varphi}{dz^2} + cE_0 \left( \frac{d\beta_s^3\gamma_s^3}{dz} \right) \frac{d\varphi}{dz} = -\omega_{RF}q\hat{E}_{acc}[\cos(\phi_s + \varphi) - \cos \phi_s]$$

Assuming **small oscillations** around the synchronous particle

$$\cos(\phi_s + \varphi) - \cos \phi_s \cong \varphi \sin \phi_s$$

Deriving both terms with respect to z and assuming an **adiabatic acceleration**

$$\frac{d\beta_s^3\gamma_s^3}{dz} \ll 1$$

⇒ The condition to have stable longitudinal oscillations and acceleration at the same time is:

$$\left. \begin{array}{l} \Omega_s^2 > 0 \Rightarrow \sin(-\phi_s) > 0 \\ V_{acc} > 0 \Rightarrow \cos \phi_s > 0 \end{array} \right\} \Rightarrow -\frac{\pi}{2} < \phi_s < 0$$

⇒ The angular frequency is simply:  $\Omega_T = \Omega_s \beta_s c$ ;

⇒ **The angular frequency scale with  $1/\gamma^{3/2}$**  that means that for ultra relativistic electrons shrinks to 0 (the beam is frozen)

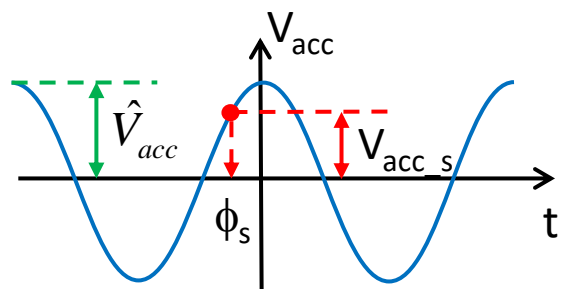

if we accelerate on the rising part of the positive RF wave we have a **longitudinal force keeping the beam bunched** around the synchronous phase.

$$\begin{cases} \varphi = \hat{\varphi} \cos(\Omega_s z) \\ w = \hat{w} \sin(\Omega_s z) \end{cases}$$

# LARGE OSCILLATIONS AND SEPARATRIX (SMOOTH APPROX)

To study the longitudinal dynamics at **large oscillations**, we have to consider the **non linear system of differential equations** without small oscillation approximations (but with adiabatic acceleration approximation). It is possible to easily obtain the following relation between  $w$  and  $\phi$  (that is the **Hamiltonian of the system** related to the total particle energy):

$$\frac{1}{2} \frac{\omega_{RF}}{cE_0\beta_s^3\gamma_s^3} w^2 + q\hat{E}_{acc}[\sin\phi - \phi \cos\phi_s] = H$$

⇒ **For each H we have different trajectories** in the longitudinal phase space

⇒ the oscillations are **stable** within a region bounded by a special curve called **separatrix**: its equation is:

$$\frac{1}{2} \frac{\omega_{RF}}{cE_0\beta_s^3\gamma_s^3} w^2 + q\hat{E}_{acc}[\sin\phi + \sin\phi_s - (\phi + \phi_s) \cos\phi_s] = 0$$

⇒ the region inside the separatrix is called **RF bucket**. The dimensions of the bucket shrinks to zero if  $\phi_s=0$ .

⇒ trajectories outside the RF buckets are **unstable**.

⇒ we can define the **RF acceptance** as the maximum extension in phase and energy that we can accept in an accelerator:

$$\Delta\phi|_{MAX} \cong 3\phi_s$$

$$\Delta w|_{MAX} = \pm 2 \left[ \frac{qcE_0\beta_s^3\gamma_s^3\hat{E}_{acc}(\phi_s \cos\phi_s - \sin\phi_s)}{\omega_{RF}} \right]^{\frac{1}{2}}$$

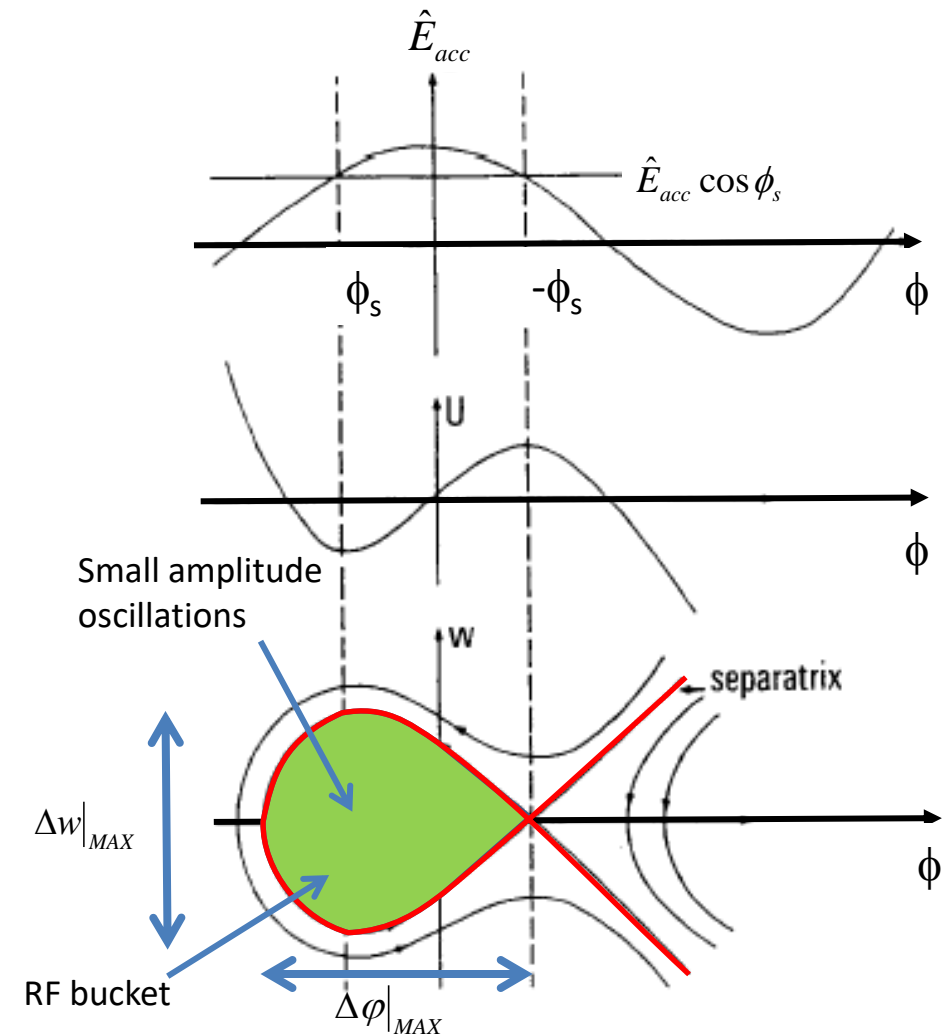

# LONGITUDINAL DYNAMICS OF LOW ENERGY ELECTRONS

From previous formulae it is clear that there is **no motion in the longitudinal phase plane for ultrarelativistic particles** ( $\gamma \gg 1$ ).



⇒ This is the case of **electrons** whose **velocity is always close to speed of light  $c$**  even at low energies.

⇒ Accelerating structures are designed to provide an accelerating field synchronous with particles moving at  $v=c$ . like **TW structures with phase velocity equal to  $c$** .

It is interesting to analyze what happens if we **inject an electron beam produced by a cathode (at low energy) directly in a TW structure** (with  $v_{ph}=c$ ) and the conditions that allow to **capture the beam** (this is equivalent to consider instead of a TW structure a SW designed to accelerate ultrarelativistic particles at  $v=c$ ).

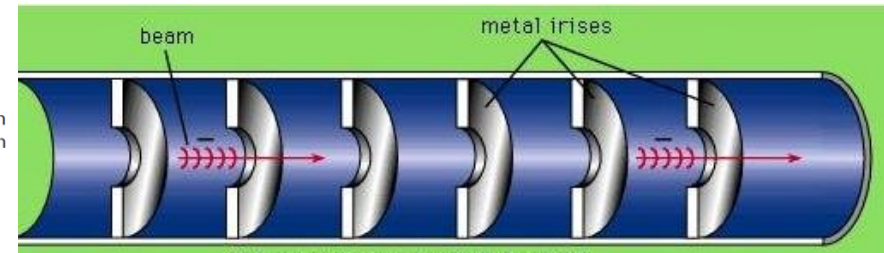
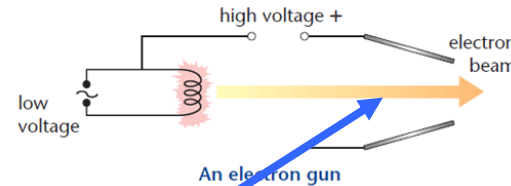

Particles enter the structure with velocity  $v < c$  and, initially, they are **not synchronous with the accelerating field** and there is a so called slippage.

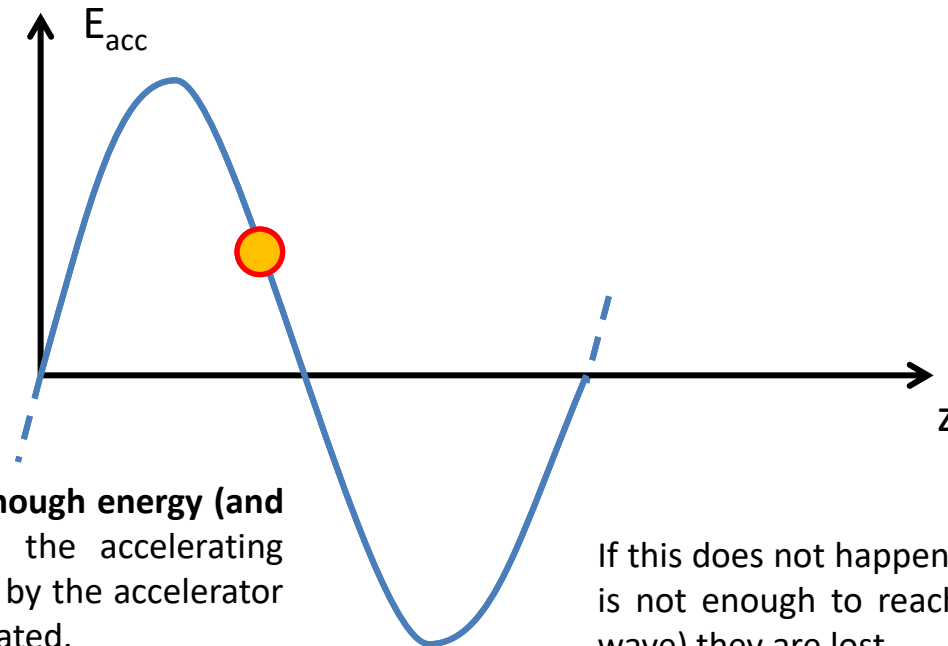

After a certain distance they can **reach enough energy (and velocity) to become synchronous** with the accelerating wave. This means that they are captured by the accelerator and from this point they are stably accelerated.

If this does not happen (the energy increase is not enough to reach the velocity of the wave) they are lost



# LONGITUDINAL DYNAMICS OF LOW ENERGY ELECTRONS: PHASE SPLIPPAGE

The **accelerating field** of a TW structure can be expressed by

$$E_{acc} = \hat{E}_{acc} \cos(\underbrace{\omega_{RF}t - kz}_{\phi(z,t)})$$



The **equation of motion** of a particle with a position  $z$  at time  $t$  accelerated by the TW is then

$$\frac{d}{dt}(mv) = q\hat{E}_{acc} \cos\phi(z,t) \Rightarrow m_0c \frac{d}{dt}(\gamma\beta) = m_0c\gamma^3 \frac{d\beta}{dt} = q\hat{E}_{acc} \cos\phi$$

It is useful to find which is the relation between  $\beta$  and  $\phi$  from an initial condition (in) to a final one (fin)

$$\sin\phi_{fin} = \sin\phi_{in} + \frac{2\pi E_0}{\lambda_{RF}q\hat{E}_{acc}} \left( \sqrt{\frac{1-\beta_{in}}{1+\beta_{in}}} - \sqrt{\frac{1-\beta_{fin}}{1+\beta_{fin}}} \right)$$



Suppose that the particle reach asymptotically the value  $\beta_{fin}=1$  we have:



$$\sin\phi_{fin} = \sin\phi_{in} + \frac{2\pi E_0}{\lambda_{RF}q\hat{E}_{acc}} \sqrt{\frac{1-\beta_{in}}{1+\beta_{in}}}$$

Should be in the interval  $[-1,1]$  to have a solution for  $\phi_{fin}$

*This limits the possible injection phases (i.e. the phase of the electrons that is possible to capture)*

This quantity is  $>0$

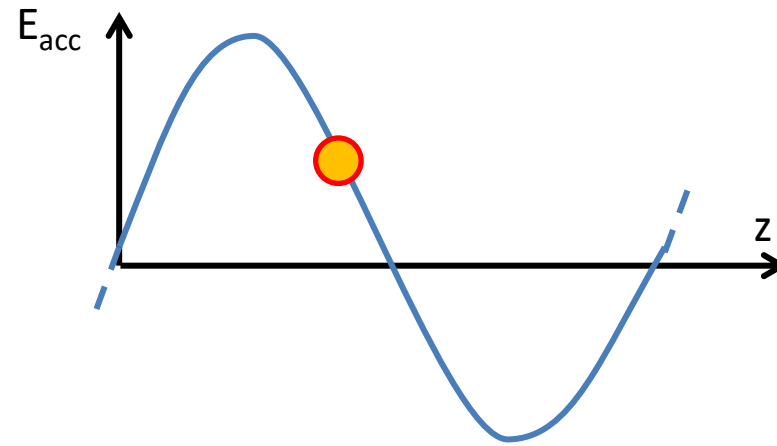
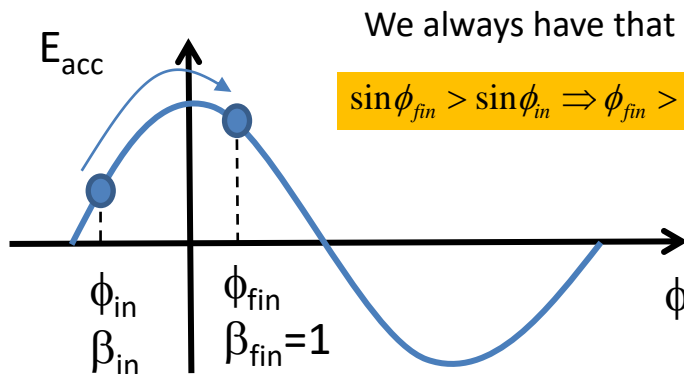
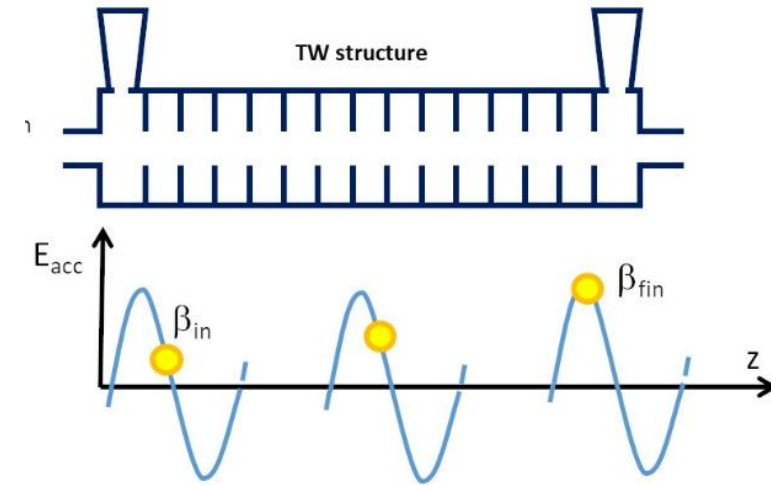

# LONGITUDINAL DYNAMICS OF LOW ENERGY ELECTRONS: CAPTURE EFFICIENCY AND BUNCH COMPRESSION

During the capture process, as the injected beam moves up to the crest, the beam is also bunched, which is caused by **velocity modulation** (velocity bunching). This mechanism can be used to compress the electron bunches (FEL applications).

## BUNCH COMPRESSION

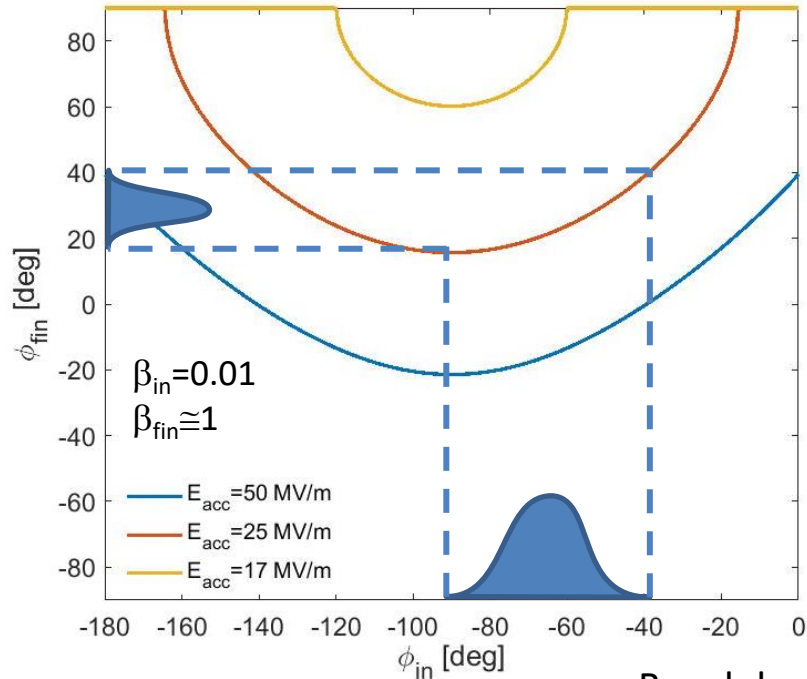

Bunch length variation

$$\sin \phi_{fin} = \sin \phi_{in} + \frac{2\pi E_0}{\lambda_{RF} q \hat{E}_{acc}} \sqrt{\frac{1 - \beta_{in}}{1 + \beta_{in}}}$$

All particles are captured

## CAPTURE EFFICIENCY

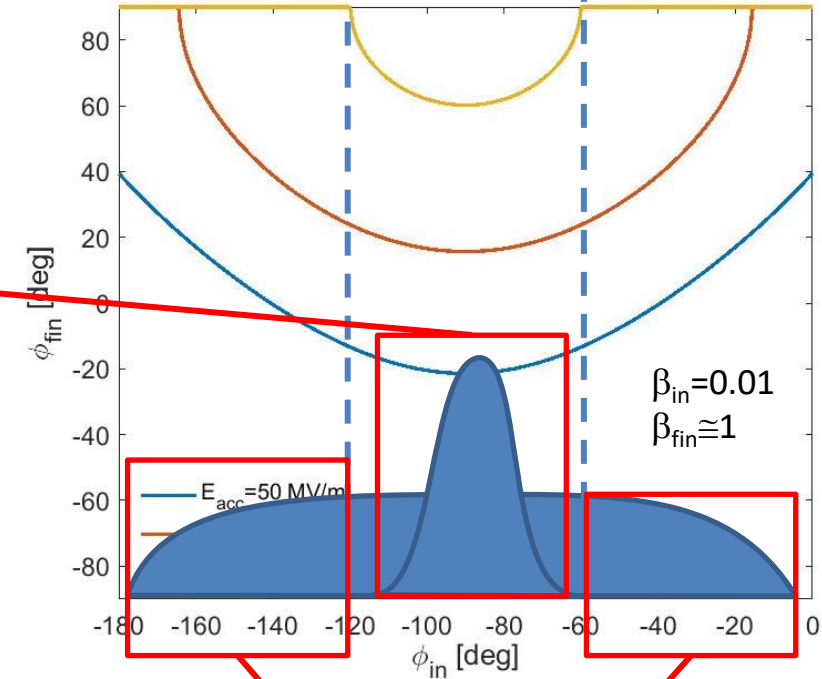

These particles are lost during the capture process

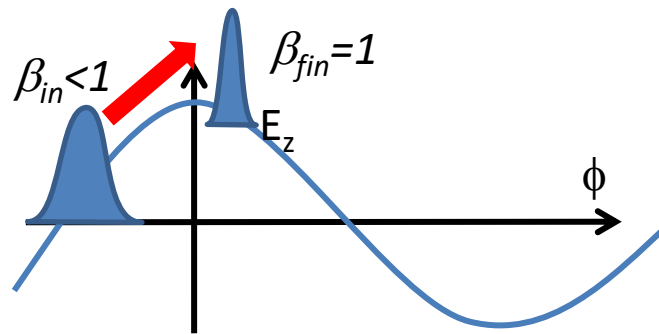

$$\Delta \phi_{fin} = \Delta \phi_{in} \frac{\cos \phi_{in}}{\cos \phi_{fin}}$$

$$\sin \phi_{fin} = \sin \phi_{in} + \frac{2\pi E_0}{\lambda_{RF} q \hat{E}_{acc}} \sqrt{\frac{1 - \beta_{in}}{1 + \beta_{in}}}$$

Depending on the injection phase we can have bunch compression or expansion

# BUNCHER AND CAPTURE SECTIONS (electrons)

Once the capture condition  $E_{RF} > E_{RF\_MIN}$  is fulfilled the fundamental equation of previous slide sets the **ranges of the injection phases  $\phi_{in}$  actually accepted**. Particles whose injection phases are within this range can be **captured** the other are **lost**.

In order to increase the capture efficiency of a traveling wave section, **pre-bunchers** are often used. They are SW cavities aimed at **pre-forming particle bunches gathering particles continuously emitted by a source**.

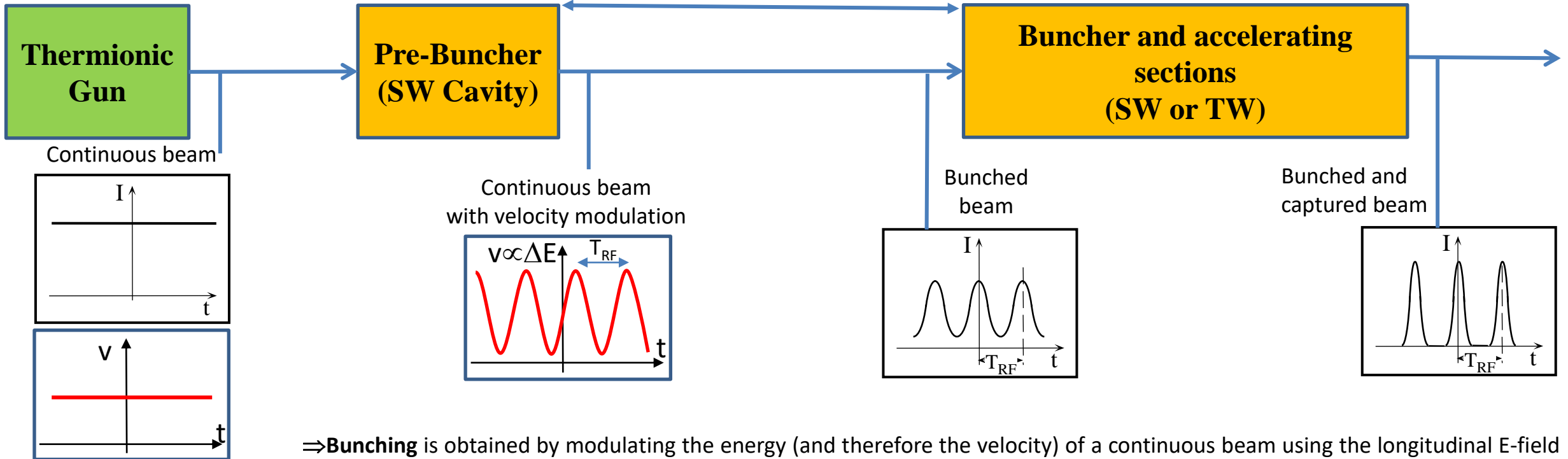

⇒ **Bunching** is obtained by modulating the energy (and therefore the velocity) of a continuous beam using the longitudinal E-field of a SW cavity. After a certain **drift space** the **velocity modulation is converted in a density charge modulation**. The density modulation depletes the regions corresponding to injection phase values incompatible with the capture process

⇒ A TW accelerating structure (**capture section**) is placed at an **optimal distance from the pre-buncher**, to capture a large fraction of the charge and accelerate it till relativistic energies. The **amount of charge lost is drastically reduced**, while the capture section provide also further beam bunching.

# LINAC: BASIC DEFINITION AND MAIN COMPONENTS

LINAC (linear accelerator) is a system that allows to accelerate charged particles through a linear trajectory by electromagnetic fields.

Longitudinal dynamics of accelerated particles

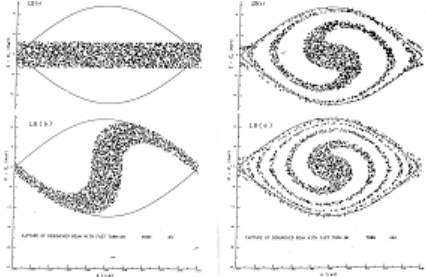

Transverse dynamics of accelerated particles

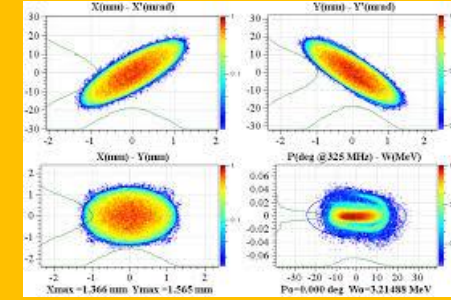

LINAC BEAM DYNAMICS

Particle source

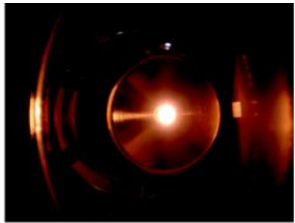

Accelerating structures

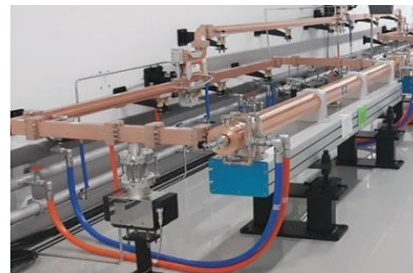

Focusing elements: quadrupoles and solenoids



LINAC COMPONENTS AND TECHNOLOGY

Accelerated beam

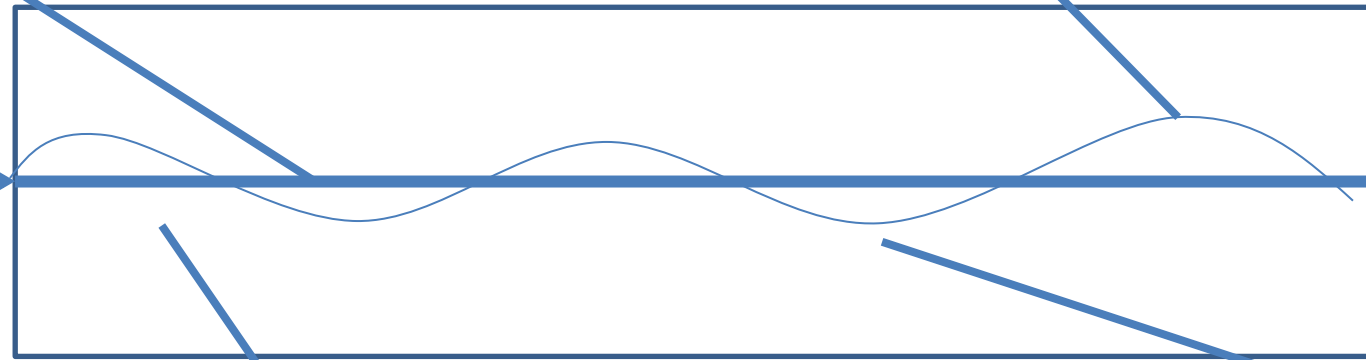

# RF TRANSVERSE FORCES

The RF fields act on the transverse beam dynamics because of the transverse components of the E and B field

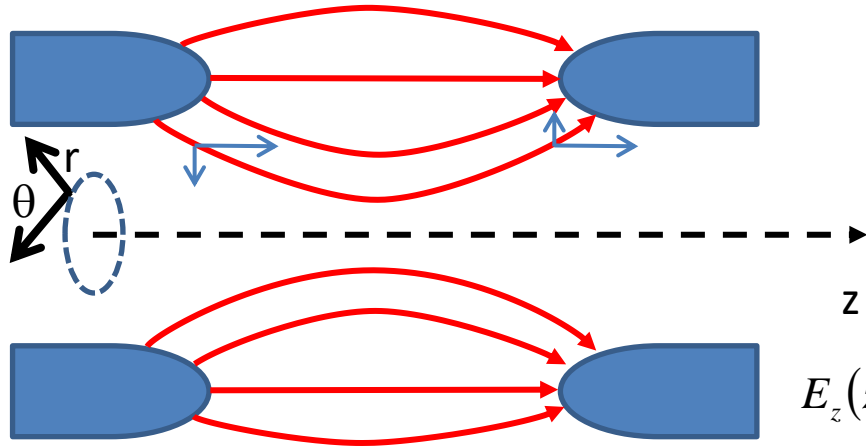

⇒ According to Maxwell equations the **divergence of the field is zero** and this implies that in traversing one accelerating gap there is a focusing/defocusing term

$$E_z(z, t) = E_{RF}(z) \cos(\omega_{RF} t)$$

$$\begin{aligned} \nabla \cdot \vec{E} &= 0 \\ \nabla \times \vec{B} &= \frac{1}{c^2} \frac{\partial \vec{E}}{\partial t} \end{aligned} \Rightarrow \begin{cases} E_r = -\frac{r}{2} \frac{\partial E_z}{\partial z} \\ B_\theta = \frac{r}{2c^2} \frac{\partial E_z}{\partial t} \end{cases}$$

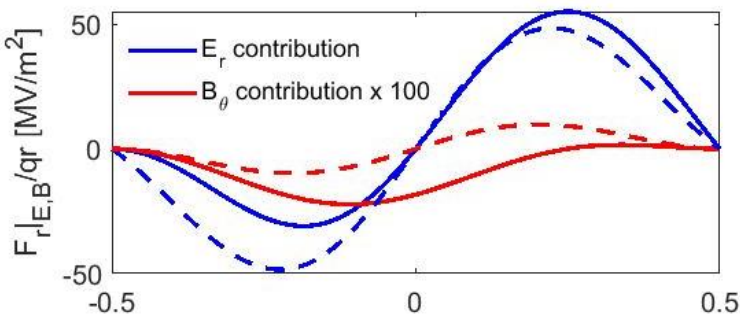
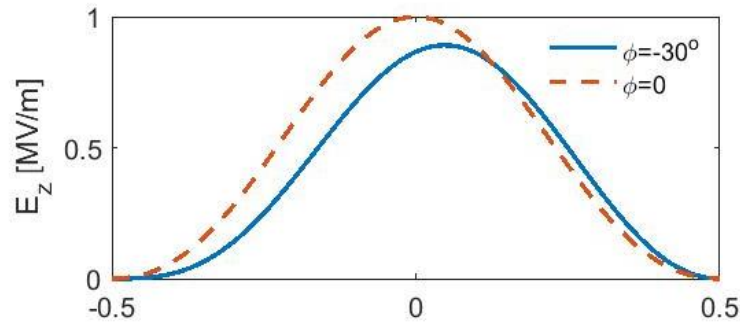

$f_{RF} = 350 \text{ MHz}$   
 $\beta = 0.1$   
 $L = 3 \text{ cm}$

$$F_r = q(E_r - vB_\theta) = -q \left[ \frac{r}{2} \left( \frac{\partial E_z}{\partial z} - \frac{\beta}{c} \frac{\partial E_z}{\partial t} \right) \right]$$

$$F_r|_E = -q \frac{r}{2} \frac{\partial E_{RF}(z)}{\partial z} \cos \left( \omega_{RF} \frac{z}{\beta c} + \phi_{inj} \right)$$

$$F_r|_B = q \frac{r}{2} \omega_{RF} \frac{\beta}{c} E_{RF}(z) \sin \left( \omega_{RF} \frac{z}{\beta c} + \phi_{inj} \right)$$

# RF DEFOCUSING

From previous formulae it is possible to calculate the **transverse momentum increase** due to the RF transverse forces. Assuming that the velocity and position changes over the gap are small we obtain to the first order:

$$\Delta p_r = \int_{-L/2}^{+L/2} F_r \frac{dz}{\beta c} = - \frac{\pi q \hat{E}_{acc} L \sin \phi}{c \gamma^2 \beta^2 \lambda_{RF}} r$$

Transverse momentum increase  $\downarrow$   
 Defocusing force since  $\sin \phi < 0$   $\swarrow$   
 Gap length  $\downarrow$   
 Defocusing effect  $\downarrow$

$$\hat{E}_{acc} = \hat{E}_{RF} / 2$$

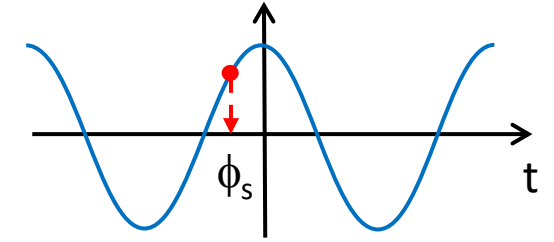

$\Rightarrow$  transverse **defocusing scales as  $\sim 1/\gamma^2$**  and **disappears at relativistic regime (electrons)**. In this case we have a compensation between the electric deflection and the magnetic one.

$\Rightarrow$  At relativistic regime (**electrons**), moreover, we have, in general,  $\phi=0$  for **maximum acceleration** and this completely cancel the defocusing effect

$\Rightarrow$  Also in the **non relativistic regime** for a correct evaluation of the defocusing effect we have to:

$\Rightarrow$  take into account the **velocity change across the accelerating gap**

$\Rightarrow$  the **transverse beam dimensions changes across the gap** (with a general reduction of the transverse beam dimensions due to the focusing in the first part)

Both effects give a **reduction of the defocusing force**

# COLLECTIVE EFFECTS: SPACE CHARGE AND WAKEFIELDS

Collective effects are **all effects related to the number of particles** and they can play a crucial role in the longitudinal and transverse beam dynamics of intense beam LINACs

⇒ **Effect of Coulomb repulsion between particles (space charge).**

⇒ These effects cannot be neglected especially at **low energy and at high current** because the space charge forces scales as  $1/\gamma^2$  and with the current **I**.



## SPACE CHARGE

EXAMPLE: Uniform and infinite cylinder of charge moving along z

$$\vec{F}_{sc} = q \frac{I}{2\pi\epsilon_0 R_b^2 \beta c \gamma^2} r_q \hat{r}$$

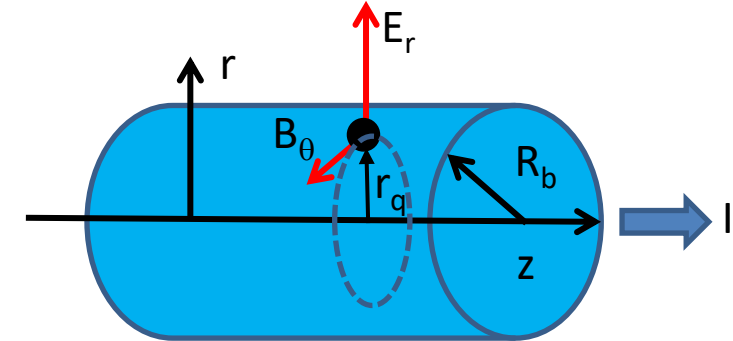

## WAKEFIELDS

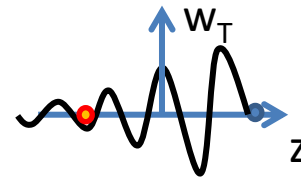

The other effects are due to the **wakefield**. The passage of bunches through accelerating structures excites electromagnetic **field**. This field can have longitudinal and transverse components and, interacting with subsequent bunches (long range wakefield), **can affect the longitudinal and the transverse beam dynamics**. In particular the **transverse wakefields**, can drive an instability along the train called **multibunch beam break up (BBU)**.

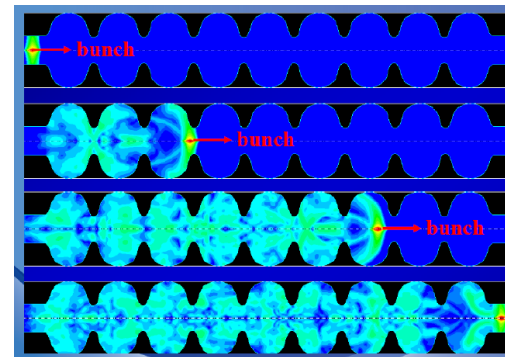

Several approaches are used to absorb these field from the structures like **loops** couplers, **waveguides**, Beam pipe **absorbers**

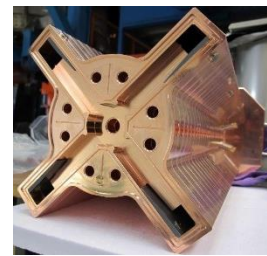

# MAGNETIC FOCUSING AND CONTROL OF THE TRANSVERSE DYNAMICS

⇒ Defocusing RF forces, space charge or the natural divergence (emittance) of the beam need to be **compensated** and controlled by **focusing forces**.



This is provided by **quadrupoles** along the beam line.  
At low energies also **solenoids** can be used

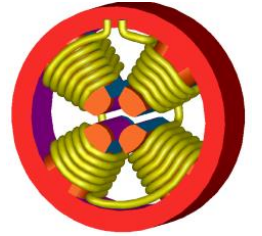

⇒ Quadrupoles are focusing in one plane and defocusing on the other. A global focalization is provided by **alternating quadrupoles** with opposite signs

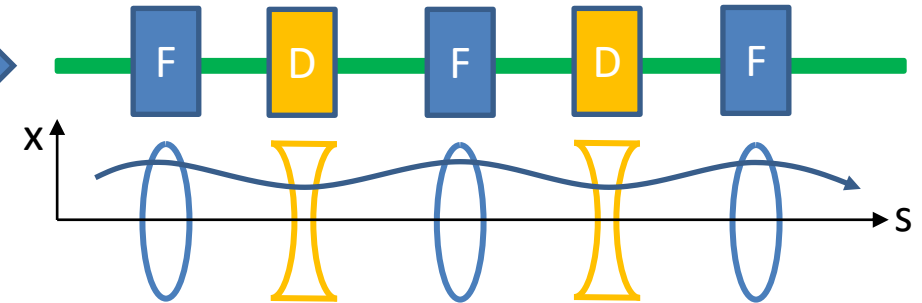

⇒ In a linac one **alternates accelerating structures with focusing sections**.

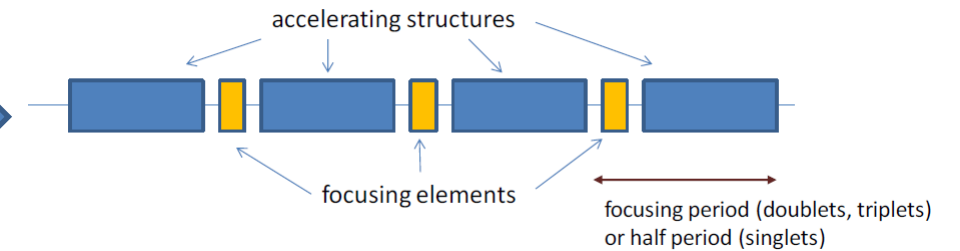

⇒ The type of magnetic configuration and magnets type/distance depend on the type of particles/energies/beam parameters we want to achieve.

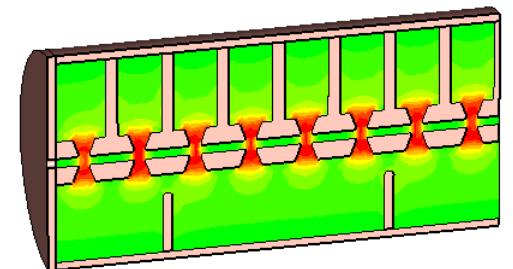



# TRANSVERSE OSCILLATIONS AND BEAM ENVELOPE

Due to the **alternating quadrupole focusing system** each particle perform transverse oscillations along the LINAC.

➔ The **equation of motion in the transverse plane** is of the type:

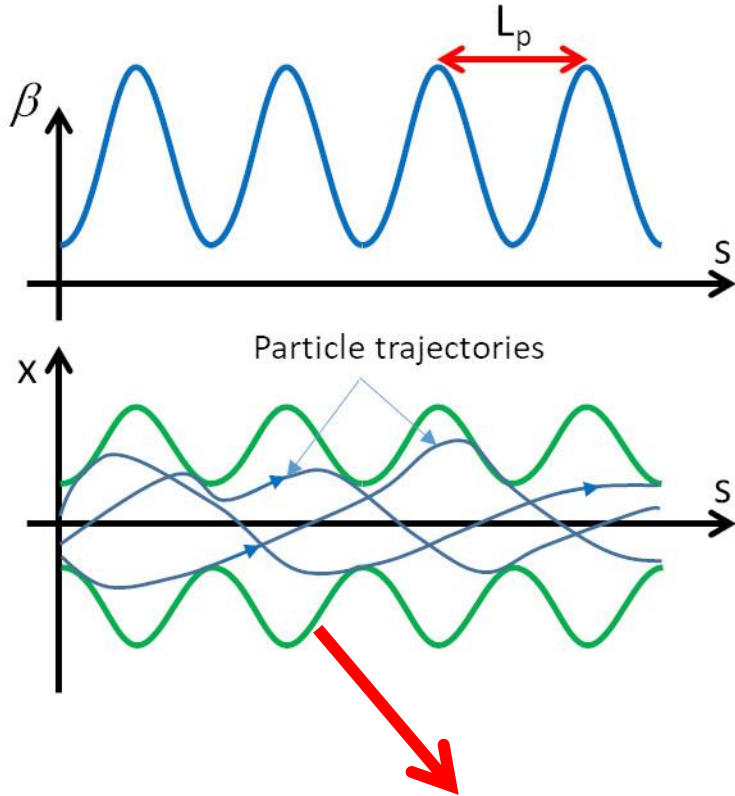

**Focusing period ( $L_p$ )**= length after which the structure is repeated (usually as  $N\beta\lambda$ ).

Term depending on the magnetic configuration      RF defocusing/focusing term

$$\frac{d^2 x}{ds^2} + \underbrace{\left[ \kappa^2(s) - k_{RF}^2(s) \right]}_{K^2(s)} x - F_{SC} = 0$$

Space charge term

➔ The **single particle trajectory is a pseudo-sinusoid** described by the equation:

$$x(s) = \sqrt{\epsilon \beta(s)} \cos \left[ \int_{s_0}^s \frac{ds}{\beta(s)} + \phi_0 \right]$$

Characteristic function (Twiss  $\beta$ -function [m]) that depend on the magnetic and RF configuration

Depend on the initial conditions of the particle

The final transverse beam dimensions ( $\sigma_{x,y}(s)$ ) vary along the linac and are contained within an **envelope**

$$\sigma = \int_{L_p} \frac{ds}{\beta(s)} \approx \frac{L_p}{\langle \beta \rangle}$$

Transverse phase advance per period  $L_p$ . For stability should be  $0 < \sigma < \pi$

# SMOOTH APPROXIMATION OF TRANSVERSE OSCILLATIONS

⇒ In case of “smooth approximation” of the LINAC (we consider an average effect of the quadrupoles and RF) we obtain a simple harmonic motion along  $s$  of the type ( $\beta$  is constant):

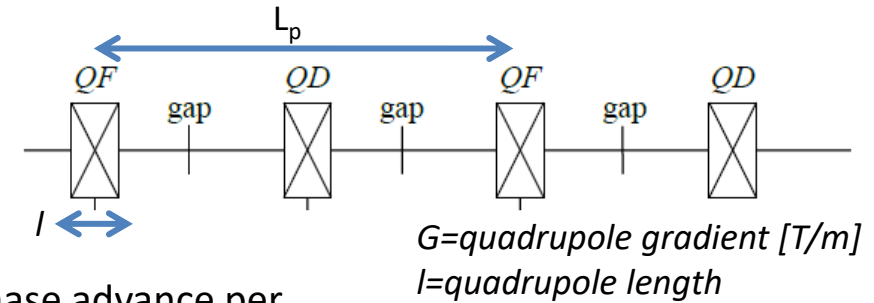
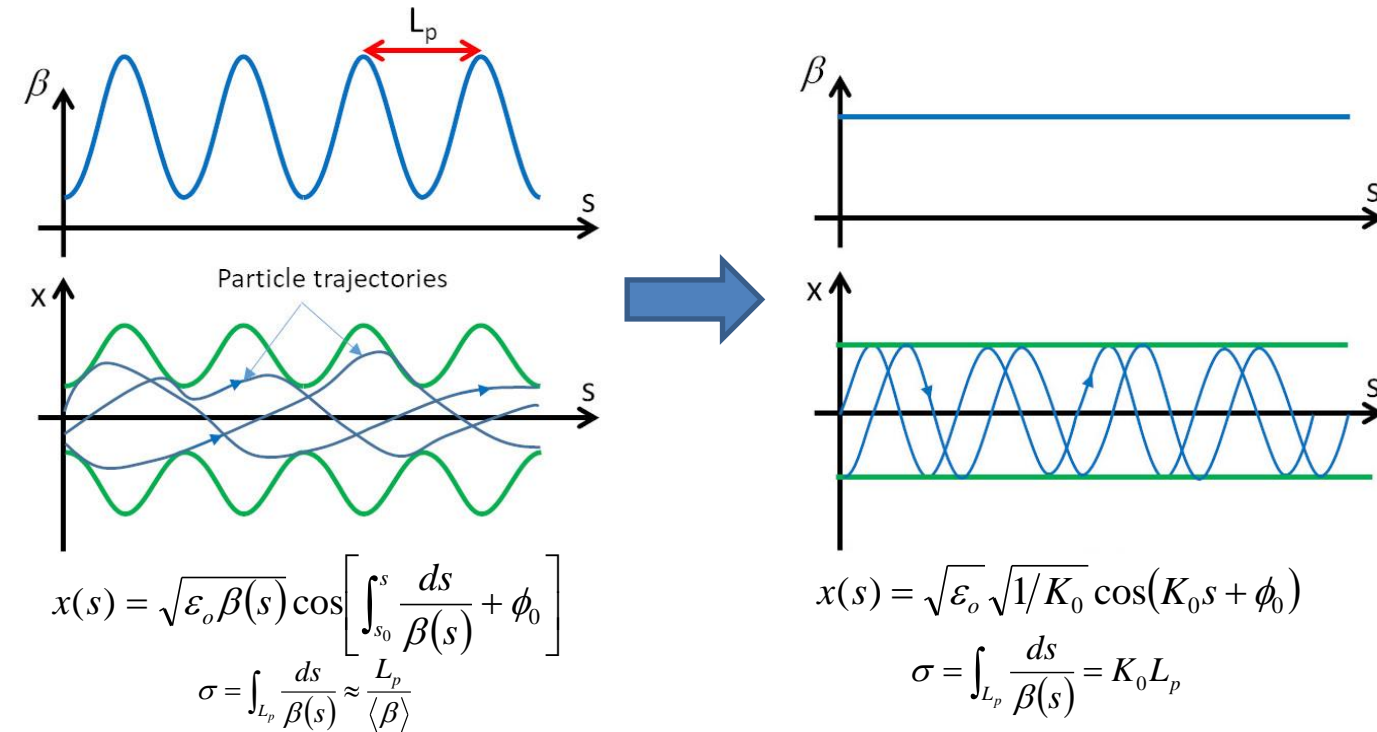

Phase advance per unit length ( $\sigma/L_p$ )

$$K_0 = \sqrt{\left( \frac{qGl}{2m_0 c \gamma_s \beta_s} \right)^2 - \frac{\pi q \hat{E}_{acc} \sin(-\phi_s)}{m_0 c^2 \lambda_{RF} (\gamma_s \beta_s)^3}}$$

Magnetic focusing elements (for a FODO)

RF defocusing term

NB: the RF defocusing term  $\propto f$  sets a higher limit to the working frequency

If we consider also the **Space Charge contribution** in the simple case of an **ellipsoidal beam** (linear space charges) we obtain:

$$K_0 = \sqrt{\left( \frac{qGl}{2m_0 c \gamma_s \beta_s} \right)^2 - \frac{\pi q \hat{E}_{acc} \sin(-\phi_s)}{m_0 c^2 \lambda_{RF} (\gamma_s \beta_s)^3} - \frac{3Z_0 q I \lambda_{RF} (1-f)}{8\pi m_0 c^2 \beta_s^2 \gamma_s^3 r_x r_y r_z}}$$

Space charge term

$I$  = average beam current (Q/T<sub>RF</sub>)  
 $r_{x,y,z}$  = ellipsoid semi-axis  
 $f$  = form factor ( $0 < f < 1$ )  
 $Z_0$  = free space impedance (377  $\Omega$ )

For ultrarelativistic electrons RF defocusing and space charge disappear and the external focusing is required to control the emittance and to stabilize the beam against instabilities.

# GENERAL CONSIDERATIONS ON LINAC OPTICS DESIGN (1/2)

## PROTONS AND IONS

- ⇒ Beam dynamics dominated by **space charge** and **RF defocusing forces**
- ⇒ Focusing is usually provided by **quadrupoles**
- ⇒ Phase advance per period ( $\sigma$ ) should be, in general, in the range 30-80 deg, this means that, at low energy, we need a strong focusing term (**short quadrupole distance and high quadrupole gradient**) to compensate for the rf defocusing, but the limited space ( $\beta\lambda$ ) limits the achievable G and beam current
- ⇒ **As  $\beta$  increases, the distance between focusing elements can increase** ( $\beta\lambda$  in the DTL goes from  $\sim 70\text{mm}$  (3 MeV, 352 MHz) to  $\sim 250\text{mm}$  (40 MeV), and can be increased to  $4-10\beta\lambda$  at higher energy ( $>40$  MeV).
- ⇒ A linac is made of a **sequence of structures, matched to the beam velocity**, and where the length of the focusing period increases with energy. As  $\beta$  increases, longitudinal phase error between cells of identical length becomes small and we can have **short sequences of identical cells** (lower construction costs).
- ⇒ Keep sufficient safety **margin between beam radius and aperture**

Transverse (x) r.m.s. beam envelope along Linac4

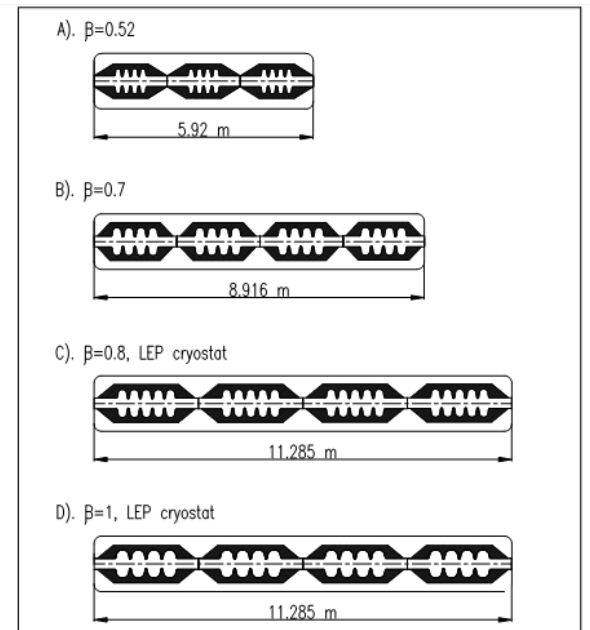
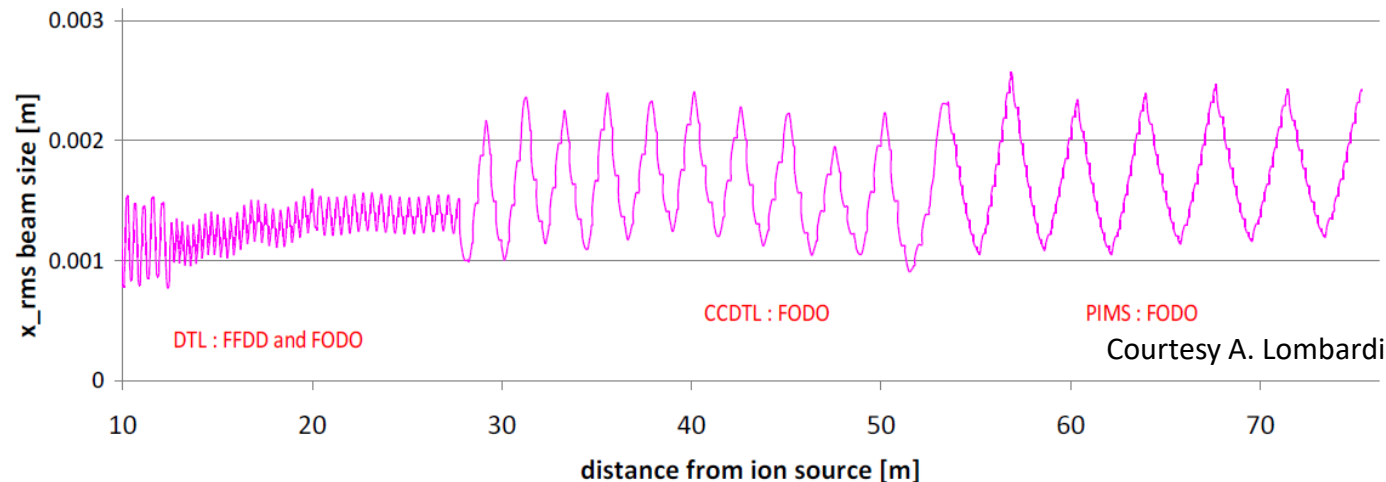

# GENERAL CONSIDERATIONS ON LINAC OPTICS DESIGN (2/2)

## ELECTRONS

- ⇒ **Space charge only at low energy and/or high peak current:** below 10-20 MeV (injector) the beam dynamics optimization has to include emittance compensation schemes with, typically solenoids;
- ⇒ At higher energies **no space charge and no RF defocusing effects** occur but we have **RF focusing due to the ponderomotive force: focusing periods up to several meters**
- ⇒ Optics design has to take into account **longitudinal and transverse wakefields** (due to the **higher frequencies used for acceleration**) that can cause energy spread increase, head-tail oscillations, multi-bunch instabilities,...
- ⇒ Longitudinal bunch compressors schemes based on magnets and chicanes have to take into account, for short bunches, the interaction between the beam and the emitted synchrotron radiation (**Coherent Synchrotron Radiation effects**)
- ⇒ All these effects are important especially in LINACs for **FEL that requires extremely good beam qualities**

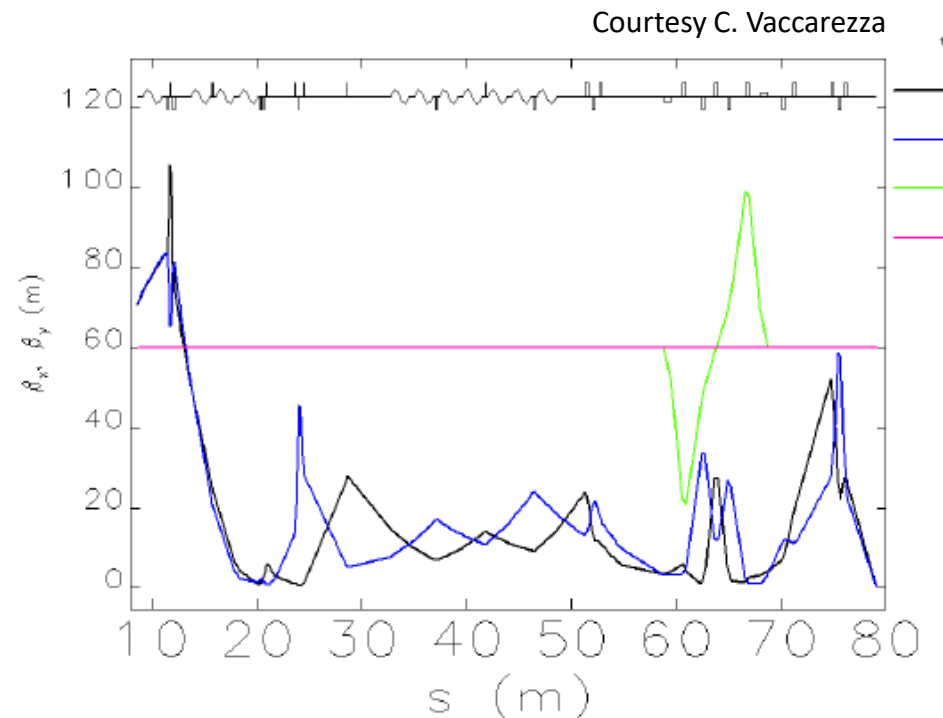
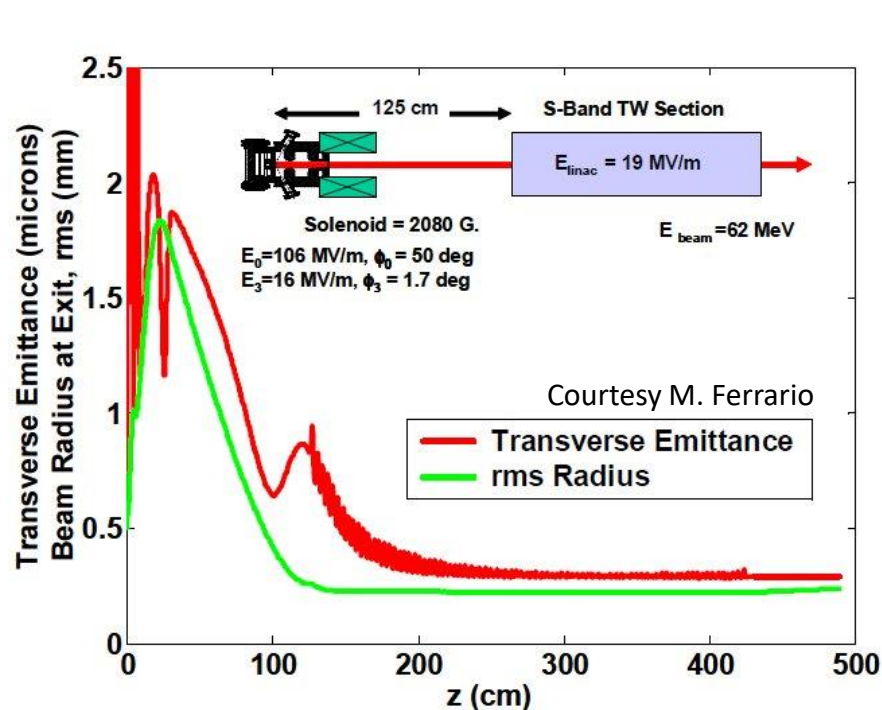

# RADIO FREQUENCY QUADRUPOLES (RFQ)

At low proton (or ion) energies ( $\beta \sim 0.01$ ), **space charge defocusing is high and quadrupole focusing is not very effective**. Moreover cell length becomes small and conventional accelerating structures (DTL) are **very inefficient**. At this energies it is used a (relatively) new structure, the **Radio Frequency Quadrupole** (1970).

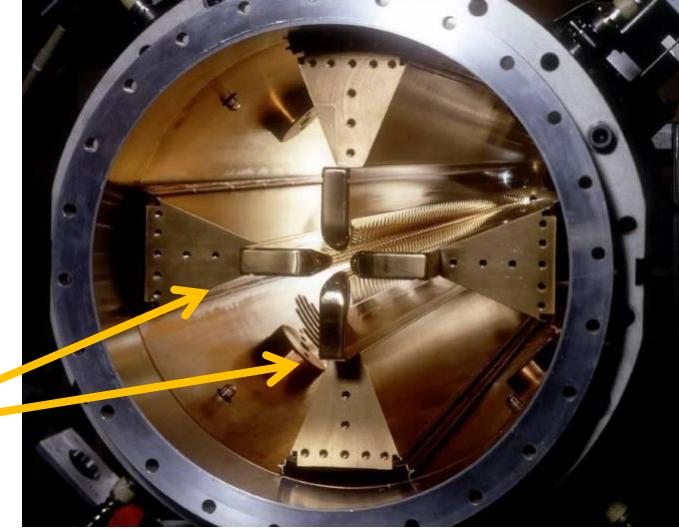
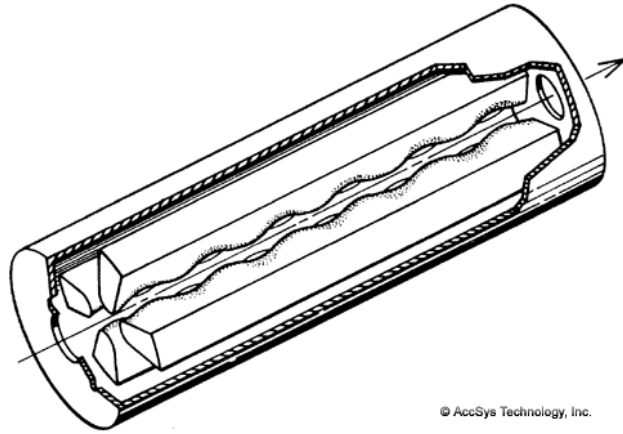

Courtesy M. Vretenar

These structures allow to simultaneously provide:

## Transverse Focusing

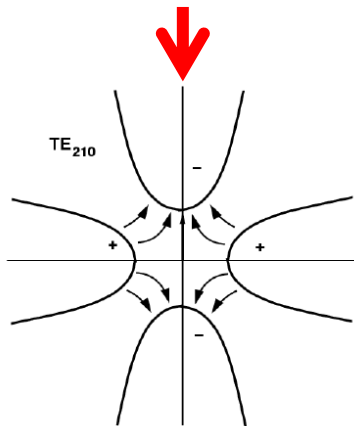

## Acceleration

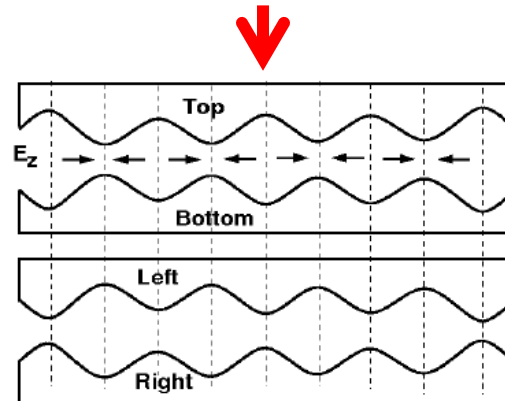

## Bunching of the beam

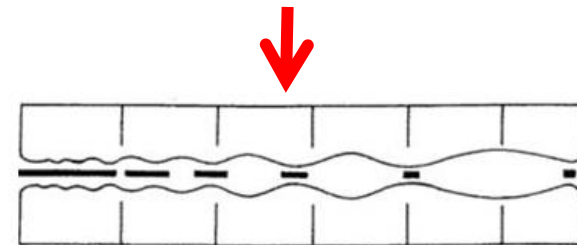

# RFQ: PROPERTIES

## 1-Focusing

The resonating mode of the cavity (between the four electrodes) is a **focusing mode: Quadrupole mode ( $TE_{210}$ )**. The alternating voltage on the electrodes produces an **alternating focusing channel** with the period of the RF (**electric focusing** does not depend on the velocity and is ideal at low  $\beta$ )

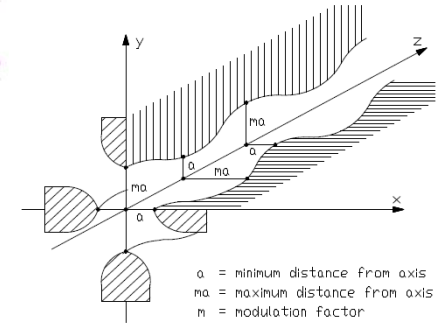
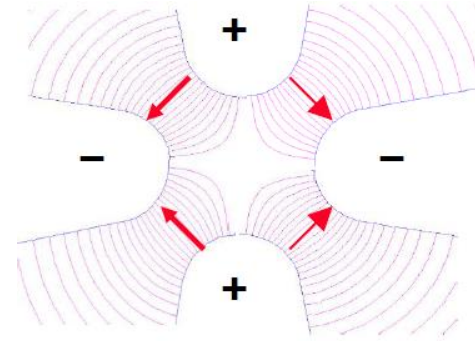

## 2-Acceleration

The vanes have a **longitudinal modulation** with period =  $\beta\lambda_{RF}$  this creates a **longitudinal component of the electric field** that accelerate the beam (the modulation corresponds exactly to a series of RF gaps).

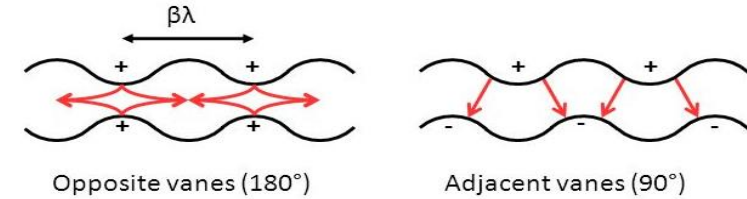

## 3-Bunching

The modulation period (distance between maxima) can be slightly adjusted to change the phase of the beam inside the RFQ cells, and the amplitude of the modulation can be changed to change the accelerating gradient. One can start at  $-90^\circ$  phase (linac) with some **bunching cells**, progressively **bunch the beam** (adiabatic bunching channel), and only in the last cells switch on the **acceleration**.

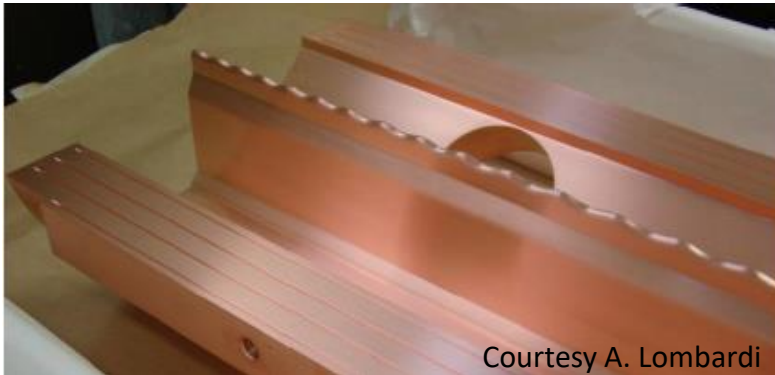
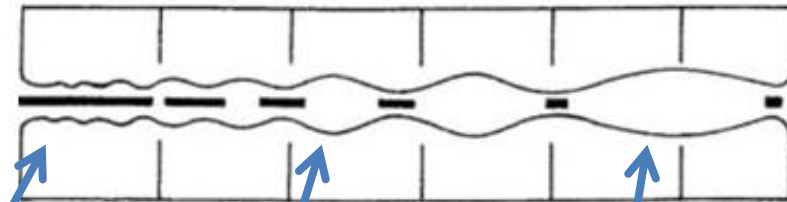

Courtesy A. Lombardi

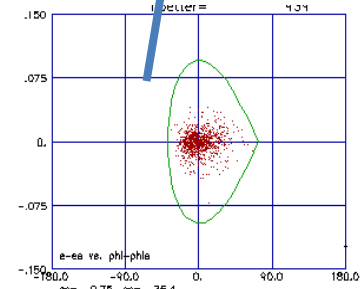
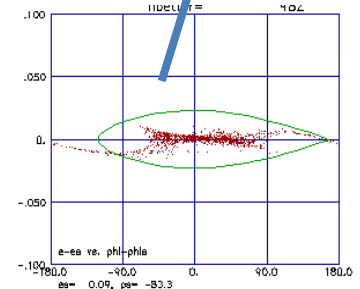
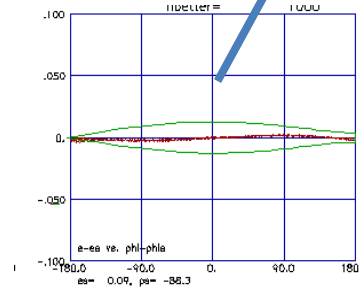

The RFQ is the only linear accelerator that can accept a low energy continuous beam.

Courtesy M. Vretenar and A. Lombardi

# RFQ: EXAMPLES

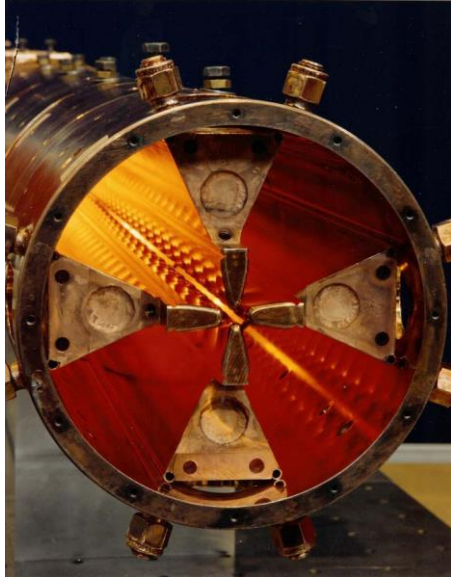

The 1<sup>st</sup> 4-vane RFQ, Los Alamos  
1980: 100 KeV - 650 KeV, 30 mA , 425 MHz



The CERN Linac4 RFQ  
45 keV – 3 MeV, 3 m  
80 mA H-, max. 10%  
duty cycle

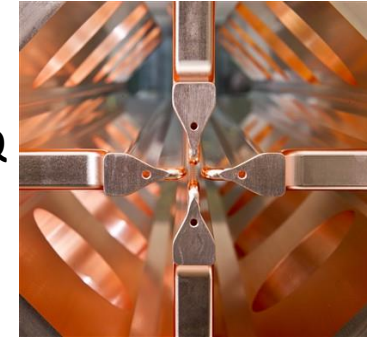

TRASCO @ INFN Legnaro  
Energy In: 80 keV  
Energy Out: 5 MeV  
Frequency 352.2 MHz  
Proton Current (CW) 30 mA

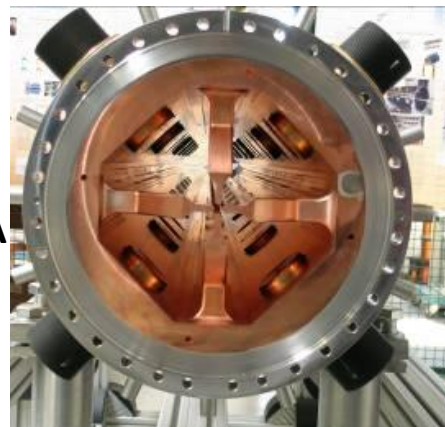

# THE CHOICE OF THE ACCELERATING STRUCTURE

In general the choice of the accelerating structure depends on:

- ⇒ **Particle type**: mass, charge, energy
- ⇒ **Beam current**
- ⇒ **Duty cycle** (pulsed, CW)
- ⇒ **Frequency**
- ⇒ **Cost** of fabrication and of operation

Moreover a given accelerating structure has also a curve of efficiency (shunt impedance) with respect to the particle energies and the choice of one structure with respect to another one depends also on this.

As example a very general scheme is given in the Table (absolutely not exhaustive).

Cavity Type	$\beta$ Range	Frequency	Particles
RFQ	0.01– 0.1	40-500 MHz	Protons, Ions
DTL	0.05 – 0.5	100-400 MHz	Protons, Ions
SCL	0.5 – 1	600 MHz-3 GHz	Protons, Electrons
SC Elliptical	> 0.5-0.7	350 MHz-3 GHz	Protons, Electrons
TW	1	3-12 GHz	Electrons



# STRUCTURE PARAMETERS SCALING WITH FREQUENCY

We can analyze how all parameters (r, Q) scale with frequency and what are the advantages or disadvantages in accelerate with low or high frequencies cavities.

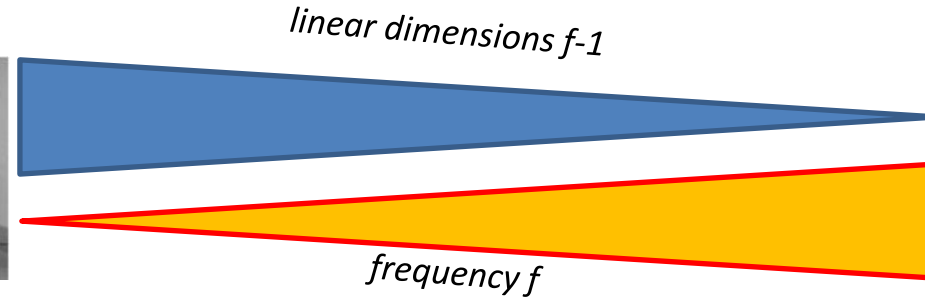
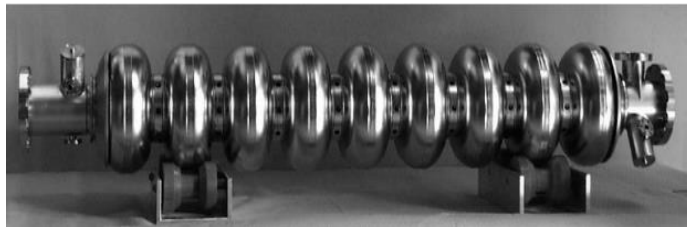

parameter	NC	SC
$R_s$	$\propto f^{1/2}$	$\propto f^2$
$Q$	$\propto f^{-1/2}$	$\propto f^{-2}$
$r$	$\propto f^{1/2}$	$\propto f^{-1}$
$r/Q$	$\propto f$	
$w_{//}$	$\propto f^2$	
$w_{\perp}$	$\propto f^3$	

} Wakefield intensity:  
related to BD issues

SW SC: 500 MHz-1500 MHz  
TW NC: 3 GHz-6 GHz  
SW NC: 0.5 GHz-3 GHz

← **Compromise  
between several  
requirements**

⇒  $r/Q$  increases at high frequency

⇒ for **NC structures** also  $r$  increases and this push to adopt **higher frequencies**

⇒ for **SC structures** the power losses increases with  $f^2$  and, as a consequence,  $r$  scales with  $1/f$  this push to adopt **lower frequencies**

⇒ On the other hand at very high frequencies (>10 GHz) **power sources** are less available

⇒ Beam interaction (**wakefield**) became more critical at high frequency

⇒ Cavity fabrication at very high frequency requires **higher precision** but, on the other hand, at low frequencies one needs more material and **larger machines**

⇒ **short bunches** are easier with higher  $f$

# THANK YOU FOR YOUR ATTENTION

## Medical applications



## Neutron spallation sources

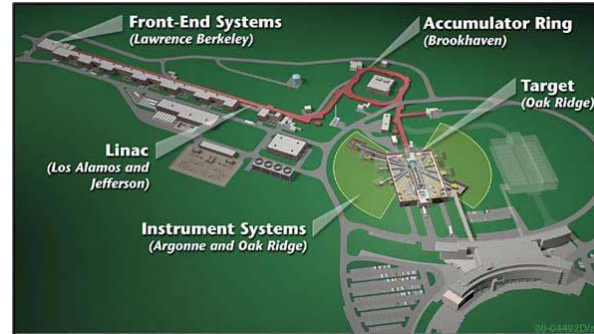

## Security: Cargo scans

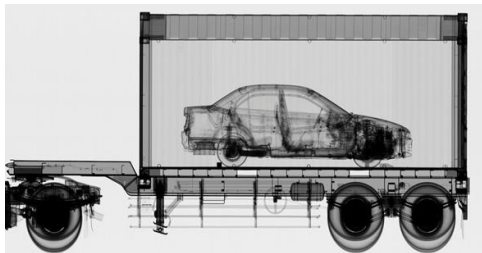

## Injectors for colliders and synchrotron light sources

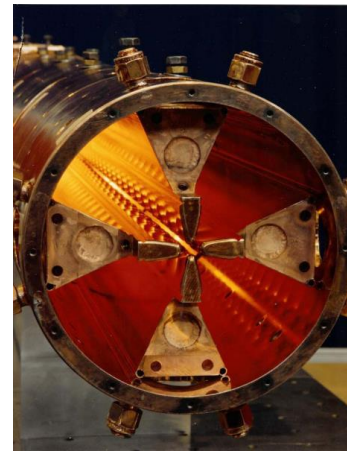

## FEL

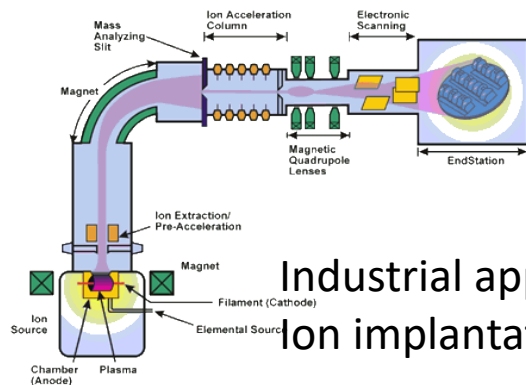

## Industrial applications: Ion implantation for semiconductors



# REFERENCES

## Reference Books:

T. Wangler, Principles of RF Linear Accelerators (Wiley, New York, 1998).

P. Lapostolle, A. Septier (editors), Linear Accelerators (Amsterdam, North Holland, 1970).

## CAS Schools

D. Alesini, Linac, Proceedings of the CERN–Accelerator–School course on Introduction to Accelerator Physics, arXiv:2103.16500 [physics.acc-ph]

D. Alesini, Power coupling, in Proceedings of the CAS–CERN Accelerator School: RF for Accelerators, Ebeltoft, Denmark, 8–17 June 2010, CERN-2011-007 (CERN, Geneva, 2010), pp.125–147, arXiv:1112.3201.

D. Alesini, Linear Accelerator Technology, Proceedings of the CAS-CERN Accelerator School on Free Electron Lasers and Energy Recovery Linacs, Vol. 1 (2018), DOI: <https://doi.org/10.23730/CYRSP-2018-001>.

S. Turner (ed.), CAS School: Cyclotrons, Linacs and their applications, CERN 96-02 (1996).

M. Weiss, Introduction to RF Linear Accelerators, in CAS School: Fifth General Accelerator Physics Course, CERN-94-01 (1994), p. 913.

N. Pichoff, Introduction to RF Linear Accelerators, in CAS School: Basic Course on General Accelerator Physics, CERN-2005-04 (2005).

M. Vretenar, Differences between electron and ion linacs, in CAS School: Small Accelerators, CERN-2006-012.

M. Vretenar, Low-beta Structures, in CAS RF School, Ebeltoft 2010

J. Le Duff, High-field electron linacs, CAS School: Fifth Advanced Accelerator Physics Course, CERN 95-06, 1995.

J. Le Duff, Dynamics and acceleration in linear structures, CAS School: Fifth General Accelerator Physics Course, CERN 94-01, 1994.

# ACKNOWLEDGEMENTS

Several pictures, schemes, images and plots have been taken from papers and previous presentations of the following authors that I would like to thank.

I would like to **acknowledge in particular the following authors:**

A. Gallo, E. Jensen, A. Lombardi, F. Tecker and M. Vretenar

I would like also to **acknowledge the following authors:**

*Hans Weise, Sergey Belomestnykh, Dinh Nguyen, John Lewellen, Leanne Duffy, Gianluigi Ciovati, Jean Delayen, S. Di Mitri, R. Carter, G. Bisoffi, B. Aune, J. Sekutowicz, H. Safa, D. Proch, H. Padamsee, R. Parodi, Paolo Michelato, Terry Garvey, Yujong Kim, S. Saitiniyazi, M. Mayierjiang, M. Titberidze, T. Andrews, C. Eckman, Roger M. Jones, T. Inagaki, T. Shintake, F. Löhl, J. Alex, H. Blumer, M. Bopp, H. Braun, A. Citterio, U. Ellenberger, H. Fitze, H. Joehri, T. Kleeb, L. Paly, J.Y. Raguin, L. Schulz, R. Zennaro, C. Zumbach. Detlef Reschke, David Dowell, K. Smolenski, I. Bazarov, B. Dunham, H. Li, Y. Li, X. Liu, D. Ouzounov, C. Sinclair*