

**DITANET**  *International Conference:*  
*Accelerator Instrumentation and Beam Diagnostics*

---

*From Nuclear Reactions and Instrumentation to  
Medical Applications*

---

*Ziad Abou Haidar – Ditanet Early Stage Researcher  
Centro Nacional de Aceleradores – CNA  
9<sup>th</sup> – 11<sup>th</sup> November 2011*

# Outline

---

- I. Introduction : Motivation & Objectives
- II. Particles and Fragments Detection Experiments
- III. Application to Quality Assurance in Radiation Therapy
- IV. Output Factor Measurements
- V. New Back to Back Detector Design
- VI. Conclusion: Achievements & Future Perspectives

# Introduction : Motivation & Objectives

- Mount a permanent setup to perform stable nuclear reaction measurements at the CNA
- Benchmark testing for instrumentation
- A reaction that fits the capabilities of the ITN-Lisbon and the CNA-Seville ( $p + {}^{58}\text{Ni}$  @ 1-6 MeV)
- Apply developed setup and knowledge to quality assurance in radiation therapy - IMRT

# Particles and Fragments Detection

## Detectors

- Surface Barrier Detector (SBD), Double Sided Silicon Strip Detector (DSSSD), Large area non segmented detector (Pad)
- SBD collimated with a 3 mm collimator : Specific scattering angle, better angular & energy resolution
- DSSSD has 16 vertical x 16 horizontal strips : Possibility of defining 256 square pixels 3x3 mm<sup>2</sup>
- Pad & DSSSD assembled in a telescope structure pointing towards the target
- A particle entering the “telescope”, leaves part of its energy in the DSSSD ( $\Delta E$ -detector), and the remaining in the Pad (E-detector)

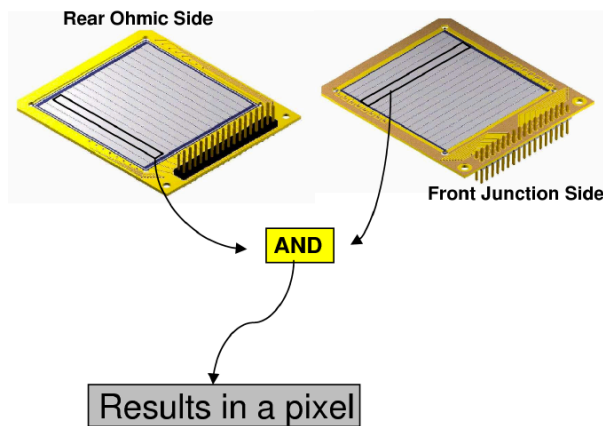

*DSSSD Pixelization*

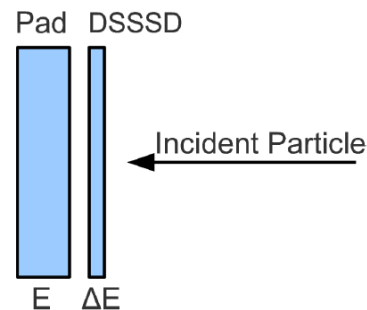

*Telescope DSSSD-Pad*



*SBD*



# Particles and Fragments Detection

## Reaction Setup

- 5 SBDs placed at forward and backward angles
- 2 Telescopes: angular range of  $45^\circ$  each (one telescope placed at backward and another one at forward angles)
- Compound  $^{58}\text{Ni}$  target with  $^{197}\text{Au}$  shell was used for normalization purposes
- Faraday cup to monitor beam current

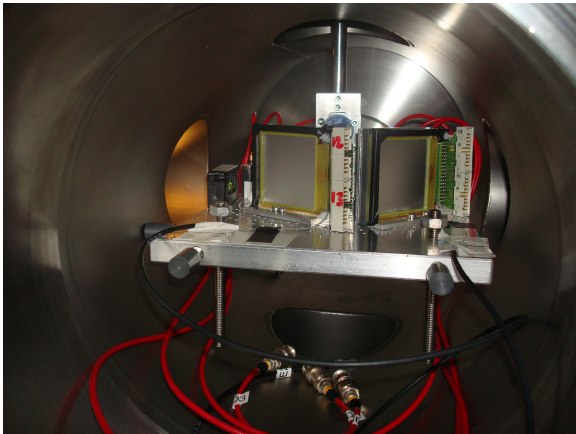

*Detectors mounted on a table installed inside the reaction chamber*

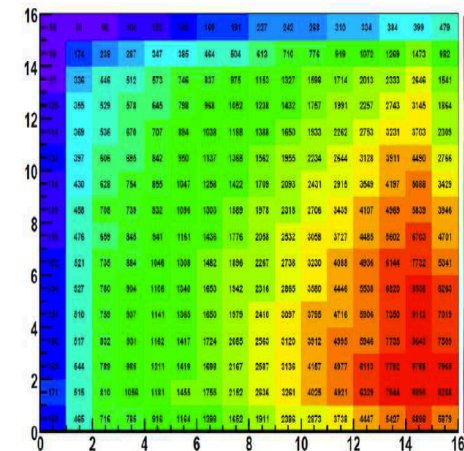

*Hitmap of a DSSSD for 3 MeV Protons on a  $^{197}\text{Au}$  Target*

# Particles and Fragments Detection

## Data Filtering

- Pixelate DSSSD/Telescopes
- Coincidence : DSSSD Front and Back, and Pad
- Multiplicity = 1: One strip on the same side was fired at a time
- Energy DSSSD Front and Back:  
tolerance 10 -100 keV depending on the noise level

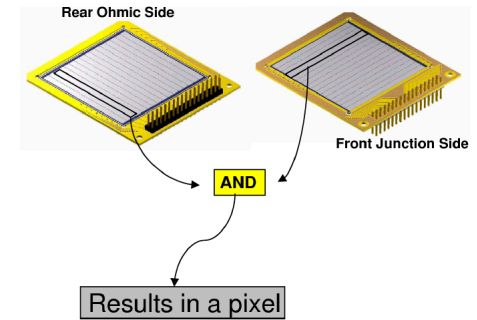

## E- $\Delta E$ Spectra & Integral

- Events lose energy in the  $\Delta E$  and stopped in the E
- E-  $\Delta E$  2D histogram for each pixel
- Integration window in terms of energy: “cut”
- Comparisons with simulations: SRIM

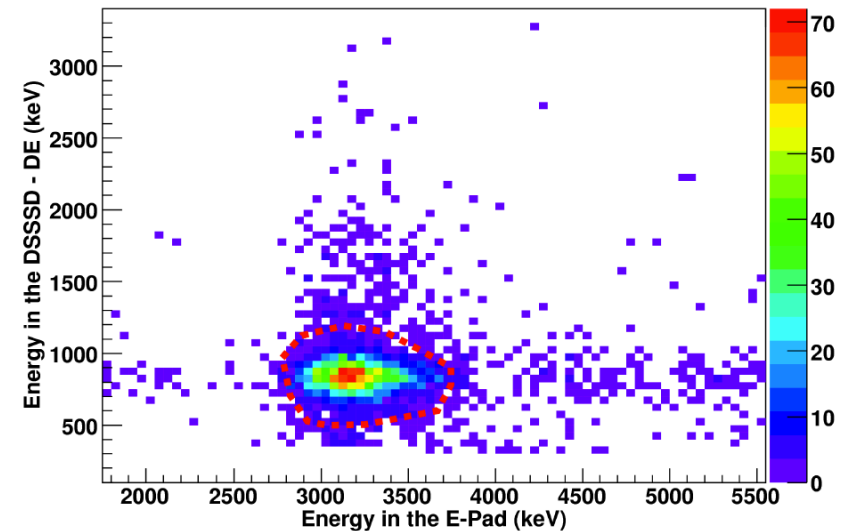

# Particles and Fragments Detection

## Cross Section

- We normalized by the 2.5 and 3 MeV energies and by the forward angles that behave accordingly to Rutherford

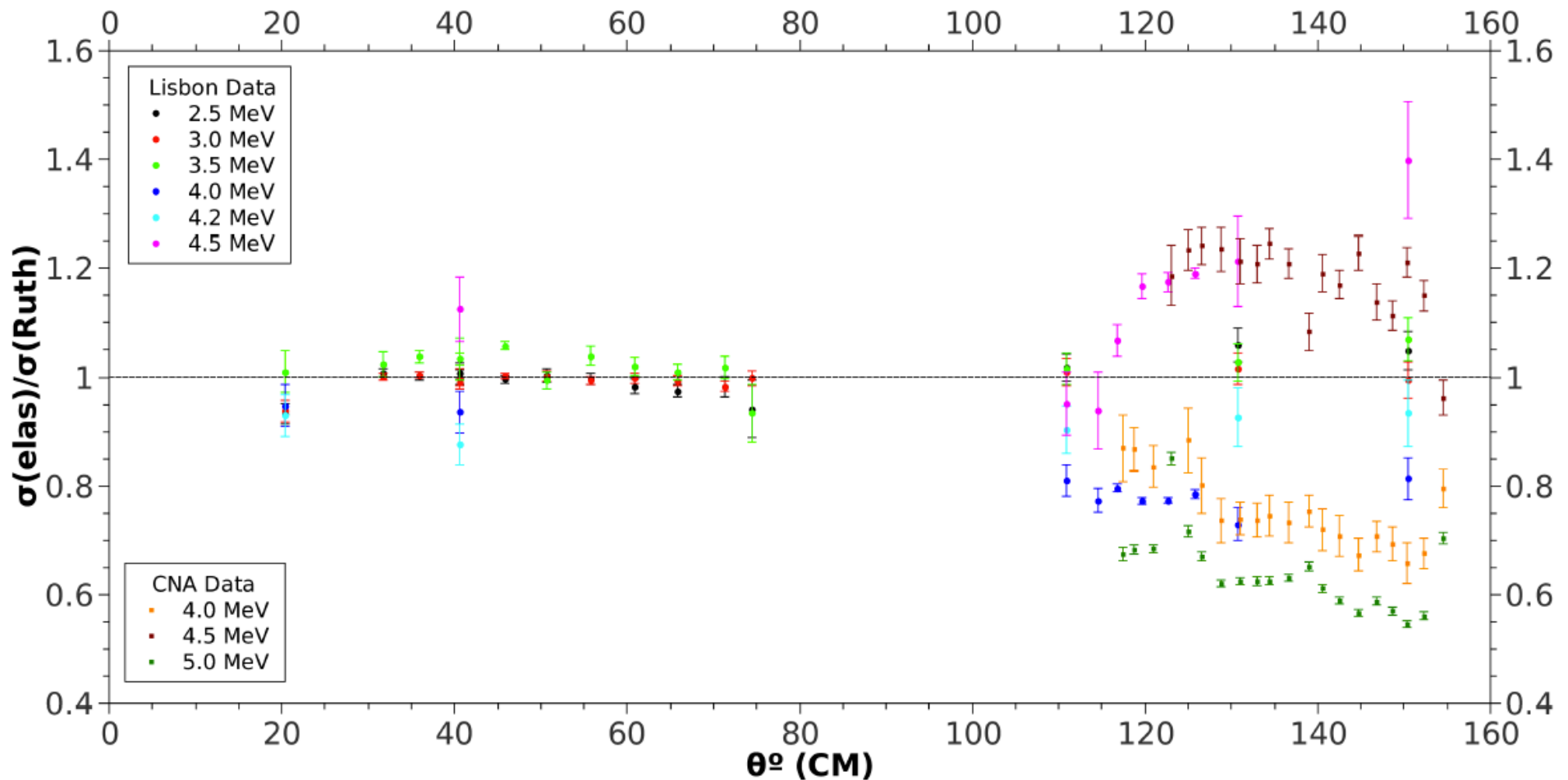

# Quality Assurance in Radiation Therapy

## The Detector

- **Model W1-SS 500** from **Micron Semiconductor Ltd.**
- Silicon Strip Detector – SSSSD (Single Sided Silicon Strip Detector)

*Thickness: 500  $\mu$ m*  
*Number of Strips: 16*  
*Strip Width: 3 mm*  
*Active Area: 50x50 mm<sup>2</sup>*

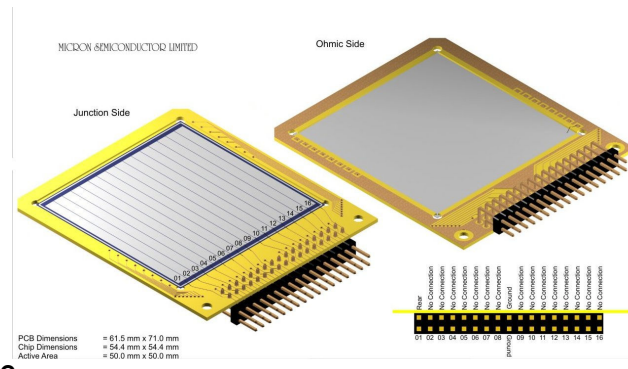

*Commercial detector*  
*Low cost*  
*Easy to handle*  
*High sensibility*  
*High counting rate*

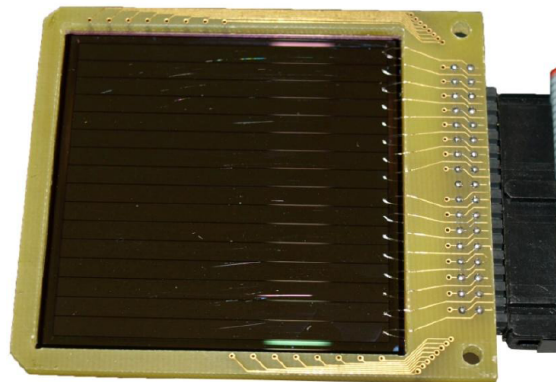

## The Accelerator

- Measurements were carried out at the **Virgin Macarena University Hospital in Seville**
- Siemens Oncor™ and Primus™



# Quality Assurance in Radiation Therapy

Two phantoms made out of polyethylene were designed and built to calibrate the detector and perform measurements

## Plane Phantom:

Perpendicular to beam direction  
Calibration & Characterization

*Linearity, Uniformity, Penumbra, Percent Depth Dose: PDD*

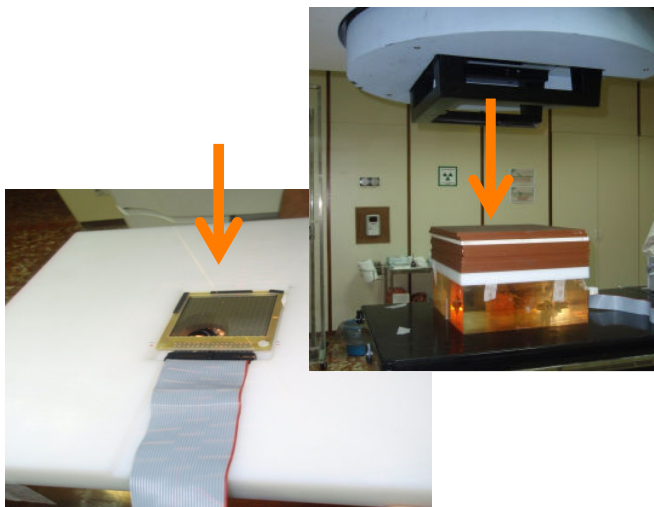

## Cylindrical Rotating Phantom:

Axial plane and can rotate with respect to the beam axis  
Similar geometry to part of the human body (tissue equiv.)  
Angular response characterization, dose maps measurements.

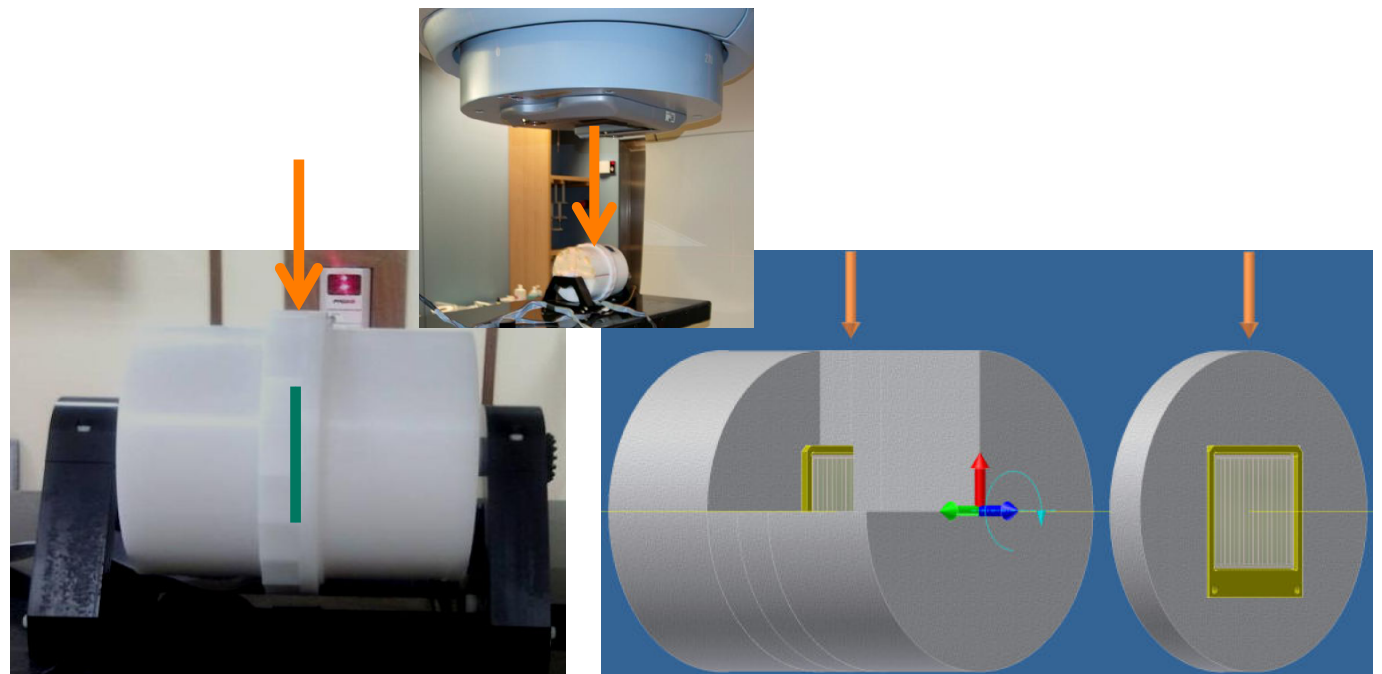



# Quality Assurance in Radiation Therapy

Two phantoms made out of polyethylene were designed and built to calibrate the detector and perform measurements

## Plane Phantom:

Perpendicular to beam direction

Calibration & Characterization

*Linearity, Uniformity, Penumbra, Percent Depth Dose: PDD*

## Cylindrical Rotating Phantom:

Axial plane and can rotate with respect to the beam axis

Similar geometry to part of the human body (tissue equiv.)

Angular response characterization, dose maps measurements.

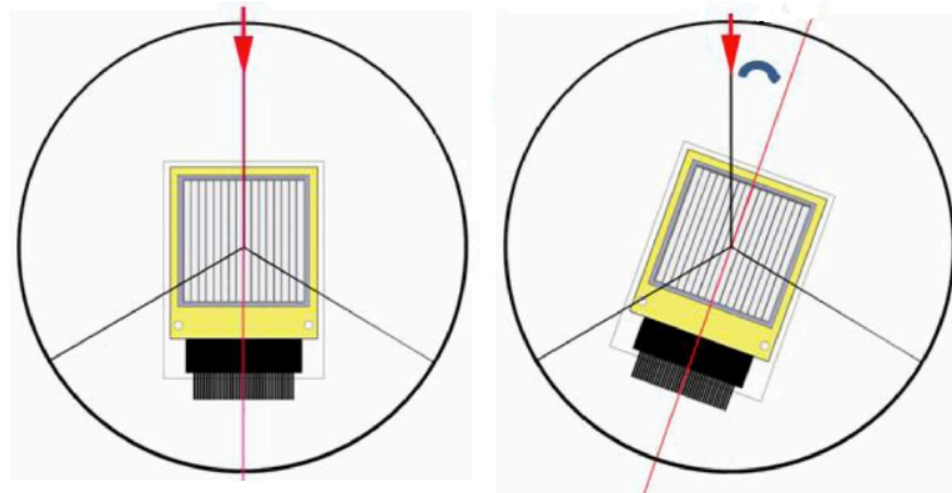
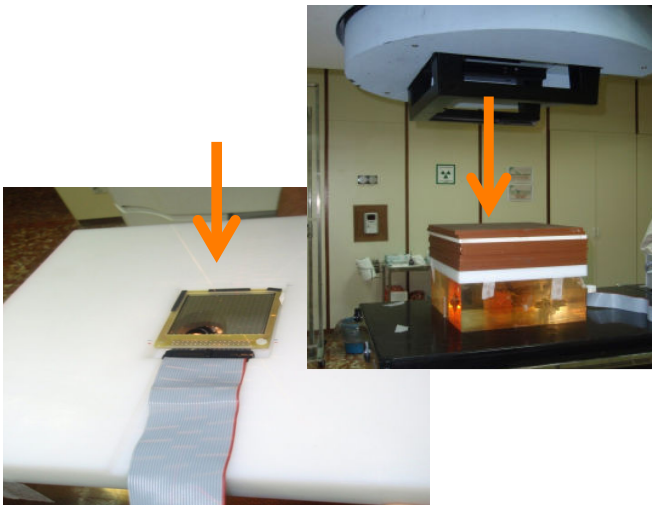

# Quality Assurance in Radiation Therapy

## Characterization of the Detector (Talk of Alessio Bocci):

- Linearity, Uniformity, Penumbra
- Percent Depth Dose: PDD
- Dose measured in each strip

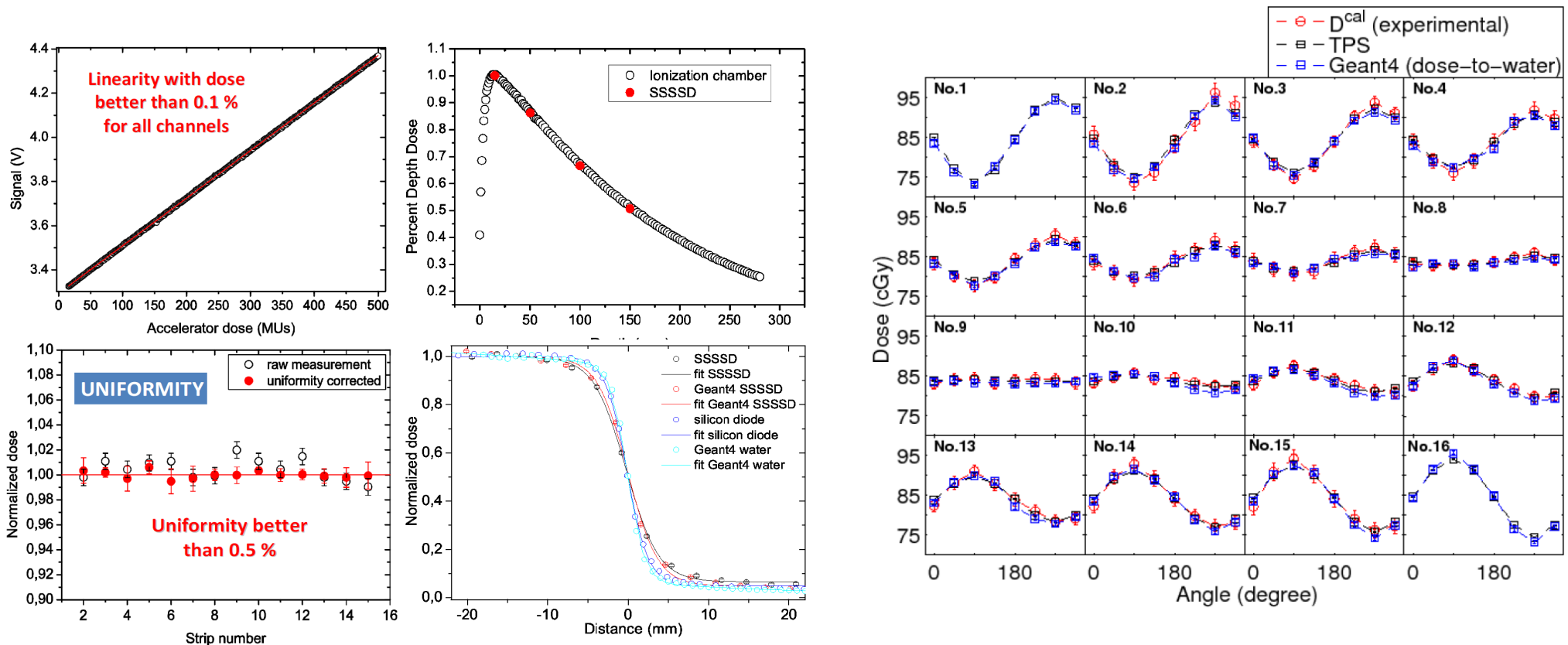

# Quality Assurance in Radiation Therapy

## Output Factor Measurements

- The output factor (OF) is defined as the ratio of the dose for any field size  $A \times A \text{ cm}^2$  to the dose for a reference field at the same source to surface distance, and at the same depth  $d$  in a slab phantom. Usually the reference field is a square field of  $10 \times 10 \text{ cm}^2$  at an SSD of  $100 \text{ cm}$
- We measured the OF of the Siemens ONCOR™ linac using the two phantoms with square and rectangular shaped fields
- The measurements were compare to data given by the Treatment Planning System (TPS)

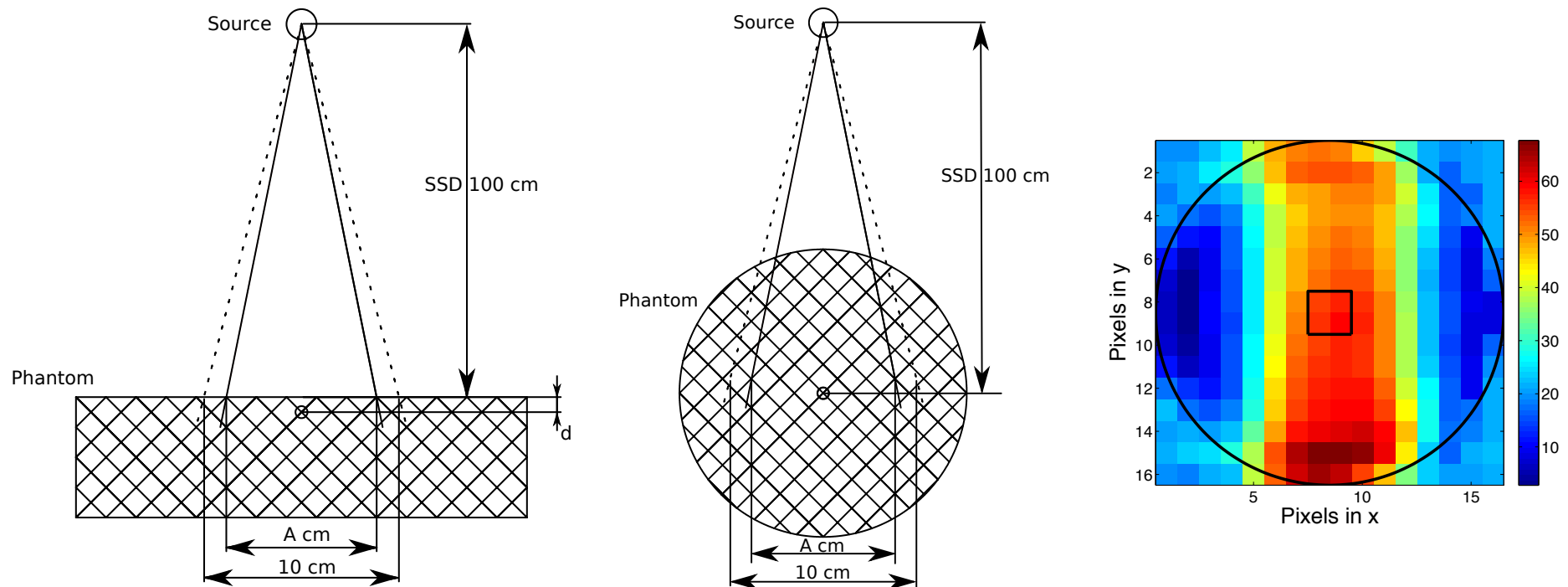



# Quality Assurance in Radiation Therapy

## Output Factor in the Slab Phantom

- Data measured with the silicon strip detector are compatible with the ones given by the TPS and/or by the ionization chamber.
- **Validation of a new method to measure the output factor in slab phantoms**

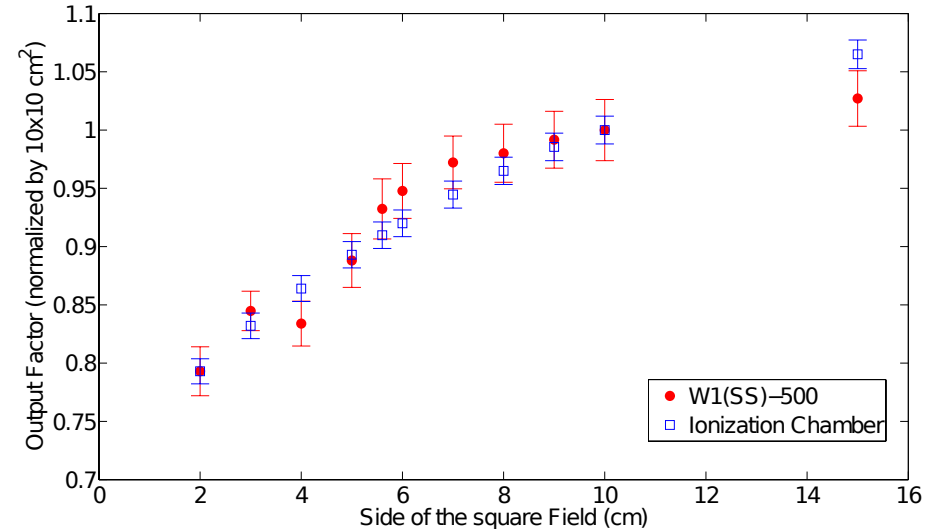
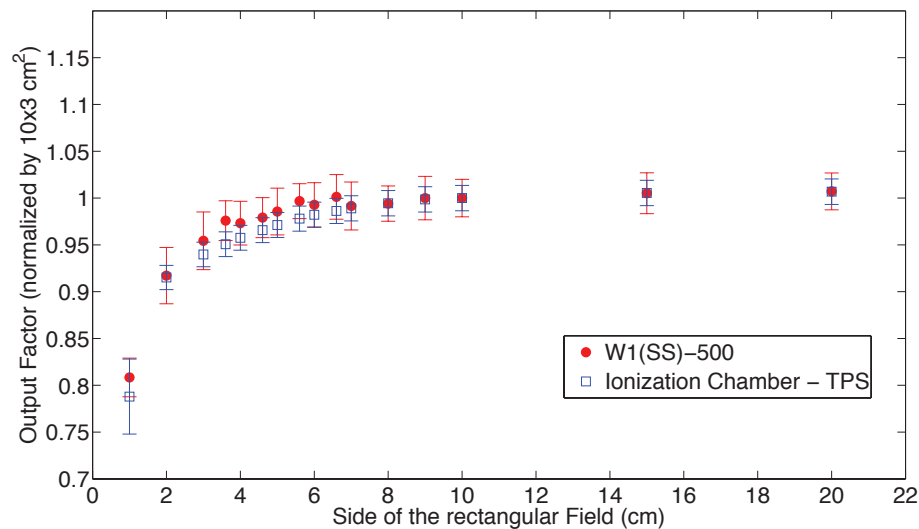

# Quality Assurance in Radiation Therapy

## Output Factor in the Cylindrical Phantom

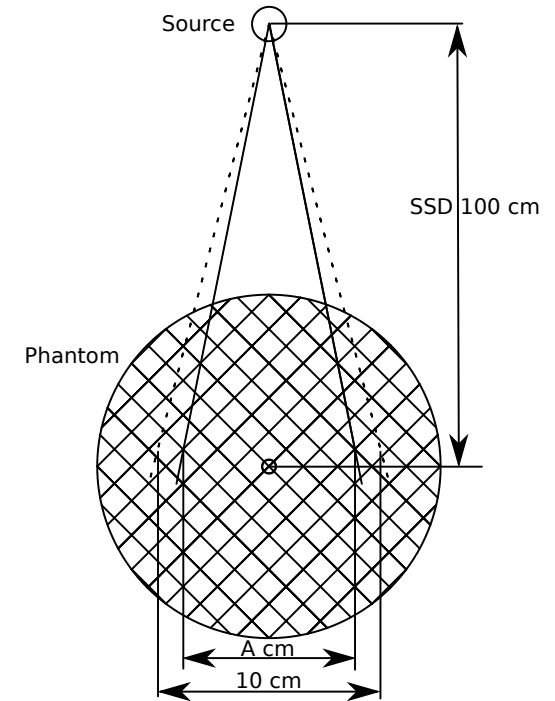
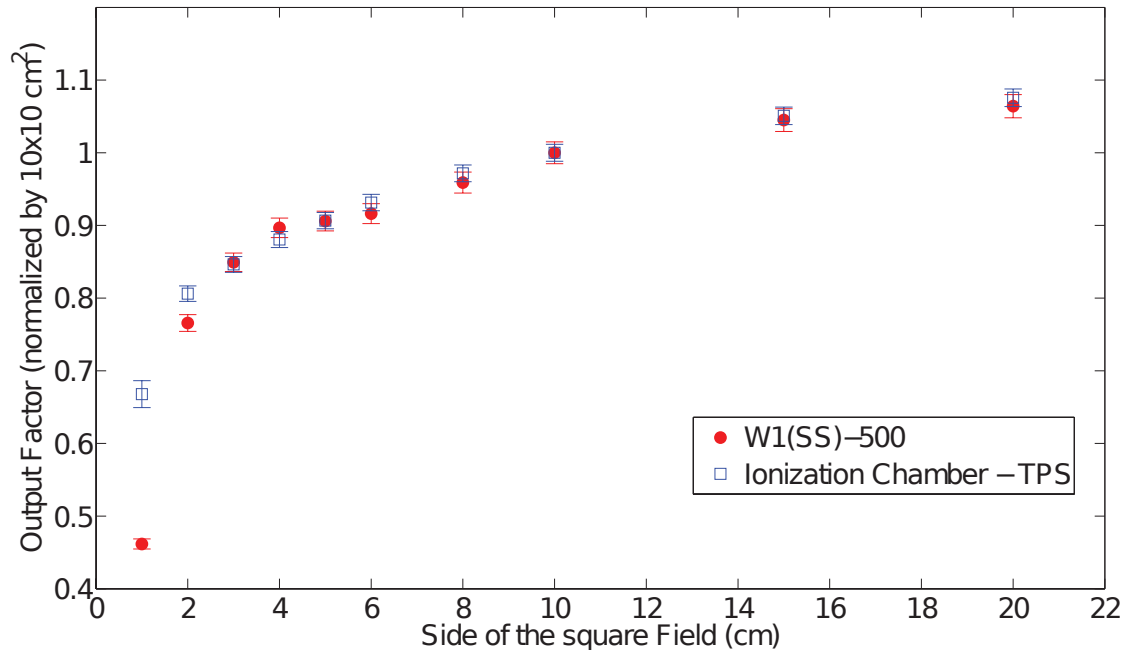

- Data are compatible within the error bars for fields bigger than 2 x 2 cm<sup>2</sup>
- For fields of 2 x 2 cm<sup>2</sup> and smaller, data are not compatible. No electronic equilibrium, since the strips and the field are of a comparable size.

# New Back to Back Detector Design

## The BB7 Detector

Based on some tests performed with a double sided BB7 detector from Micron Semiconductor Ltd., we are in the process of designing a new detector that will have these characteristics:

- It consists on two single sided BB7 assembled back to back
- Bigger active area (64 x 64 mm<sup>2</sup>)
- Smaller strip pitch (2 mm)
- A 2 Dimensional detector
- A new packaging & cabling

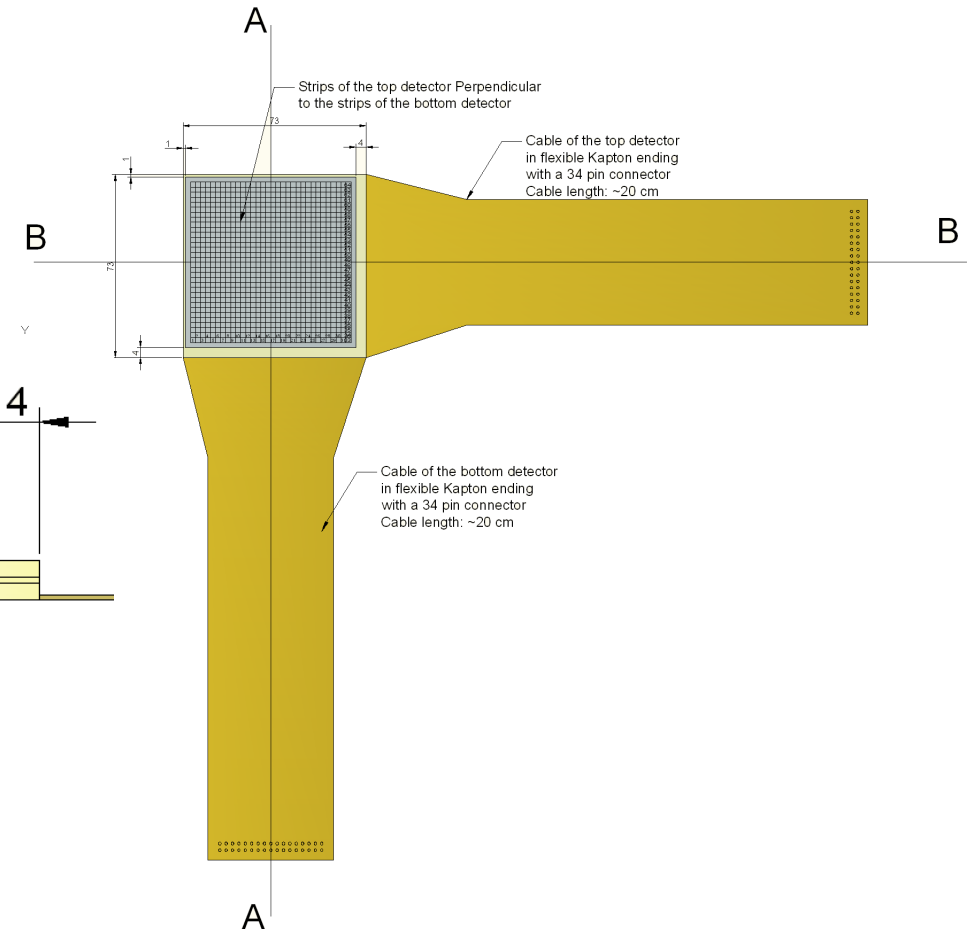
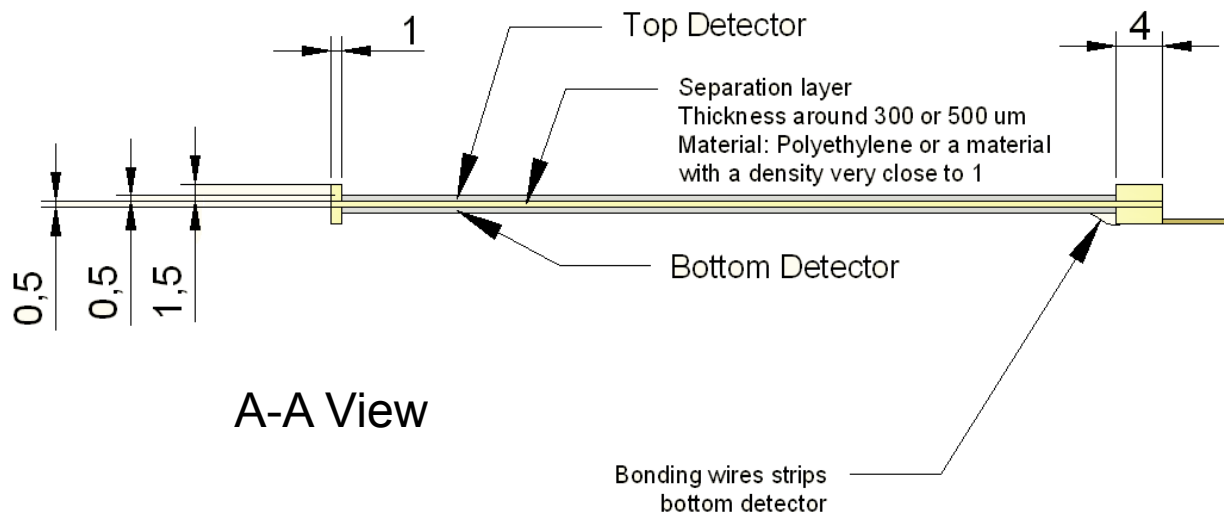

# New Back to Back Detector Design

## The New Phantom and Data Acquisition

The new detector will be coupled to:

- An improved and versatile rotating phantom
- A more precise electronics
- A more user friendly data acquisition system : couple Labview to Matlab and to C/C++

***The whole system will generate real time online dose maps in axial planes***

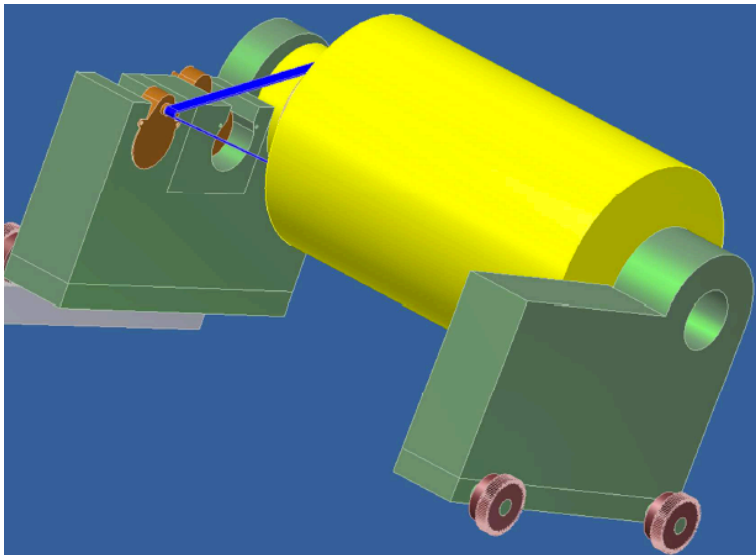

# Conclusion: Achievements & Future Perspectives

- Phase I: We have developed and installed at the CNA a permanent system dedicated for nuclear reaction measurements and analysis. We have obtained new non existing data of the elastic scattering of protons on  $^{58}\text{Ni}$  target at low energies.
- Phase II: We have applied the previously mounted setup, and the experience acquired on a feasibility study for a project oriented towards complex radiation therapy treatment verification (RADIA2 project). We established a new technique to measure the dose delivered to a patient in the axial plane using silicon strip detectors  
**- Submitted for Patent at the OEMP - Oficina Española de Patentes y Marcas - Ministry of Industry & Commerce: Number P201101009 (13/09/2011)**
- Phase III: Design and construction of a new detector that offers 2D measurements with a spatial resolution of the order of 1 mm.

***The ultimate objective is to obtain real time online dose maps in the axial plane and to start implementing our complete device and system in hospitals.***

# Collaboration

This work would not have been possible without the collaboration of several people from the following institutions:

- **Centro Nacional de Aceleradores – CNA, Seville**
- **Department FAMN of the University of Seville**
- **Instalaciones INABENSA SA, Seville**
- **Hospital Virgen Macarena, Sevilla**
- **School of Engineering of the University of Seville**

## References:

- **A. Bocci et al., *Silicon strip detector for a novel 2D dosimetric method for radiotherapy treatment verification, submitted to NIM-A (Sept. 2011)***
- **Z. Abou-Haidar et al., *Output factor determination for dose measurements in axial and perpendicular planes using a silicon strip detector, submitted to PRST-AB, special ed. DITANET conference, Oct 2011***
- ***Conference ESTRO 2011, Radiation and Oncology, Volume 99 , Supplement 1 (2011)***
- ***Conference SEFM, Spanish Society for Medical Physics – 10-13 May 2011***
- ***Conference ICTR-PHE 2012, Abstract accepted***

# Conclusiones y Perspectivas

- El cáncer es la segunda causa de muerte más frecuente en los países desarrollados. Cada año se diagnostican más de un millón de casos únicamente en la Unión Europea.
- *Caracterización de un detector de tiras de silicio para una nueva técnica de obtención de mapas de dosis en planos axiales, depositadas en tratamientos de radioterapia IMRT (Intensity Modulated Radiation Therapy).*
- Hemos aplicado el conocimiento adquirido sobre los detectores de silicio usados en reacciones nucleares a la física médica
- Hemos mostrado que un detector de silicio (W1 SS-500) es capaz de medir un mapa de dosis en el **plano axial** mediante un algoritmo de reconstrucción, el sistema esta en proceso de ser patentado.
- El sistema tiene buenas características para ser usado como verificación de tratamiento en radioterapia:
  - Linealidad  $< 1\%$ , uniformidad  $< 0.5\%$ , compatibilidad entre la dosis calibrada del SSSSD y los cálculos del TPS menos de  $2\%$  en las tiras del borde del detector, y menos de  $1\%$  en las tiras centrales
- Actualmente, estamos investigando posibles mejoras del sistema:
  - Detector con área activa mas grande
  - Mejora de la resolución espacial: disminuir la anchura de tira
  - Utilizar un sistema de detección en 2 dimensiones (tiras perpendiculares)