

An alternative form of supersymmetry with reduced cross-sections and modified experimental signatures

Roland Allen, Bailey Tallman, Jehu Martinez, Aleksy Rodriguez, Dario Ramirez-Pico,
Kane Rylander, Alzaib Maknojia, and Michael Cantu
Department of Physics and Astronomy, Texas A&M University

Why have SUSY and dark matter WIMPs not yet been seen?

A unified explanation is provided in these papers:

- (1) arXiv:2307.04255 – an alternative form of supersymmetry (susy), which can be regarded as a cousin to conventional supersymmetry (SUSY), with reduced cross-sections and different experimental signatures.**
- (2) Our earlier papers, including those below – a dark matter WIMP consistent with experiment and observation, which can be regarded as a cousin to other candidates, but with well-defined mass and couplings, and quantitative predictions.**

[1] Reagan Thornberry, Maxwell Throm, John Killough, Dylan Blend, Michael Erickson, Brian Sun, Brett Bays, Gabe Frohaug, and Roland Allen, EPL (European Physics Letters), 34, 49001 (2021), arXiv:2104.11715 [hep-ph].

[2] Caden LaFontaine, Bailey Tallman, Spencer Ellis, Trevor Croteau, Brandon Torres, Sabrina Hernandez, Diego Cristancho Guerrero, Jessica Jaksik, Drue Lubanski, and Roland Allen, Universe 7, 270 (2021), arXiv:2107.14390 [hep-ph].

[3] Bailey Tallman, Alexandra Boone, Caden LaFontaine, Trevor Croteau, Quinn Ballard, Sabrina Hernandez, Spencer Ellis, Adhithya Vijayakumar, Fiona Lopez, Samuel Apata, Jehu Martinez, and Roland Allen, proceedings of ICHEP 2022, <https://pos.sissa.it/414/>, DOI 10.22323/1.414.0988], arXiv:2210.05380 [hep-ph].

[4] Bailey Tallman, Alexandra Boone, Adhithya Vijayakumar, Fiona Lopez, Samuel Apata, Jehu Martinez, and Roland Allen, Letters in High Energy Physics LHEP-342 (2023), arXiv:2210.15019 [hep-ph].

This talk, and the associated papers, are addressed to young physicists who are open to fresh ideas -- and to senior physicists who are able to break free of ingrained and limited preconceptions!

But the present theory should be regarded as an extension and enhancement of previous work, rather than a competitor.

For example, most of our cross-section calculations are obtained using slight modifications of brilliantly designed software such as MadGraph and MicrOMEGAs.

The descriptions of supersymmetry and the dark matter WIMP may be regarded as purely phenomenological theories, but are related to the broader theory of arXiv:2302.10241 (which may itself be regarded as a cousin to string theory).

These theories (with testable near-term predictions) might help provide further motivation for new experimental facilities, including hadron and lepton colliders, underground experiments, and astrophysical observations – as described in the following slides.

Plots below and in the next slide are by Bailey Tallman, based on MadGraph calculations by Bailey Tallman, Kane Rylander, and Alzaib Maknojia.

All cross-sections for representative susy processes are obtained from the minimal supersymmetric standard model (MSSM) as modified in the present theory.

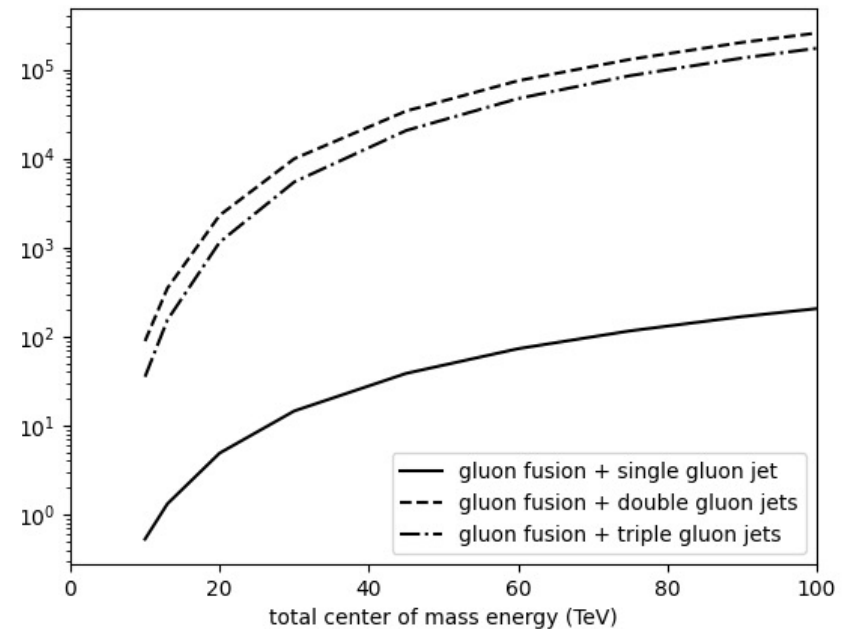
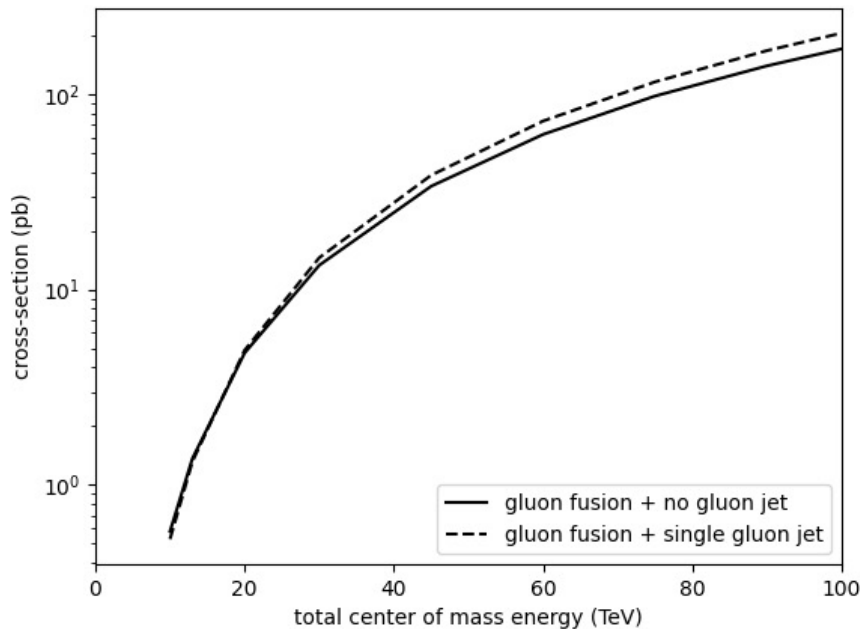

production of left-handed top squark with mass of 400 GeV

In the present theory sfermions do not decay, but must be detected via hadronization with *second-order* electromagnetic, strong, weak, and Higgs interactions.

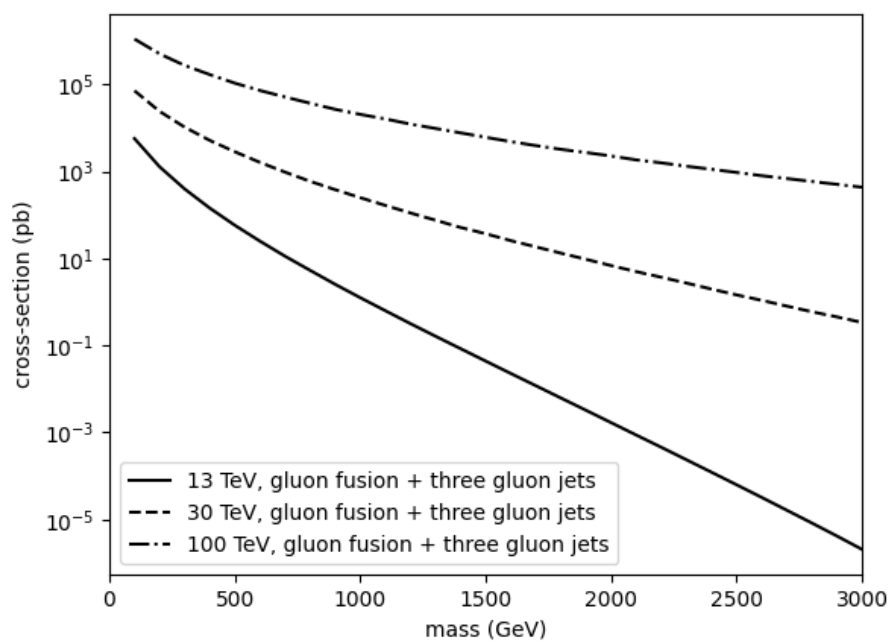
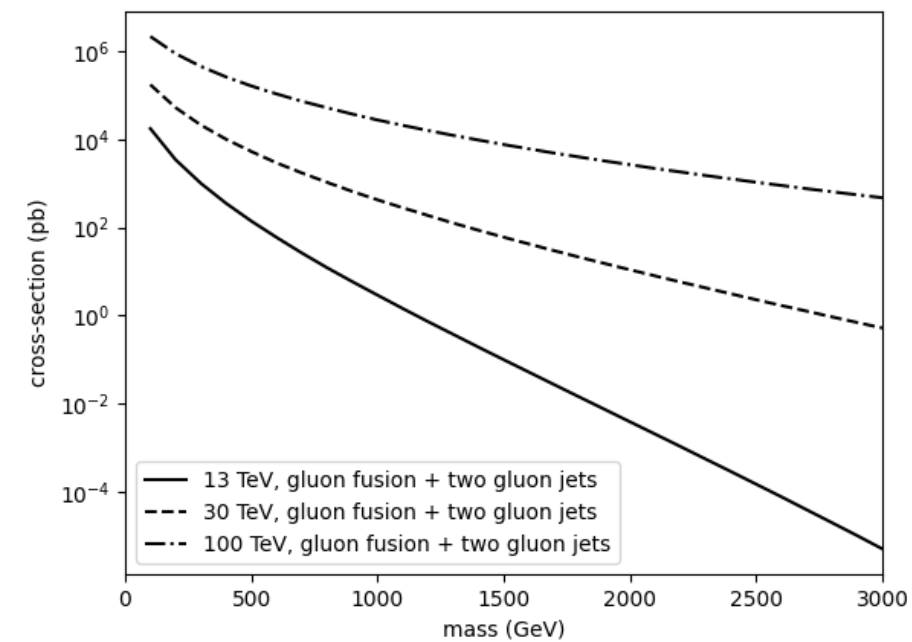
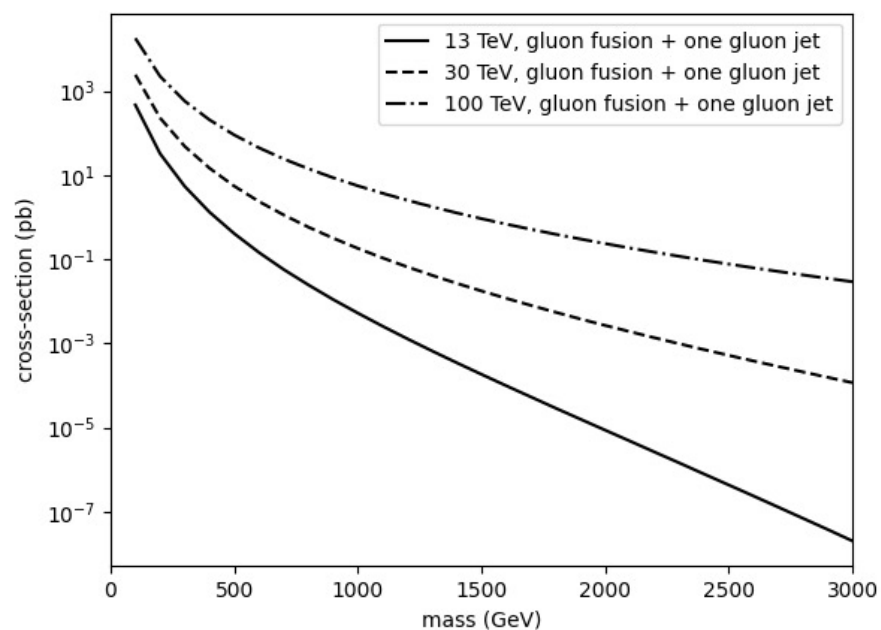
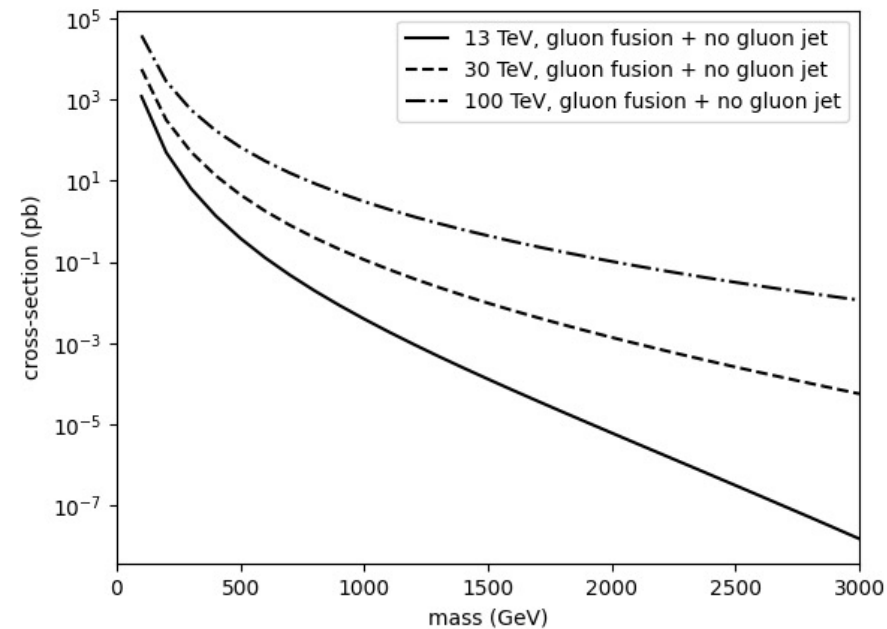

The present theory is based on a reinterpretation of scalar fields – which now include standard complex fields ϕ , auxiliary fields F , and real fields φ of a new kind.

These new fields turn out to have only second-order (electromagnetic, weak, strong, gauge, and Higgs) couplings.

The dark matter candidate in the present theory is an excitation of one such field φ_h , called the (lowest-mass) higgson field in our earlier papers because its second-order couplings are the same as the first-order couplings of the Higgs field ϕ_H .

in the present theory sfermions are similarly excitations of fields φ_α with second-order couplings that are the same as the first-order couplings of the fermion partner (or the conventional sfermion).

This fact eliminates many processes (Feynman diagrams) for production and decay of both sfermions and bosinos (gluinos, neutralinos, and charginos).

The non-observation of both dark-matter WIMPs and superpartners then has a simple interpretation: Second-order couplings imply that cross-sections are reduced and experimental signatures are modified.

The present version of supersymmetry (called susy here to avoid confusion) initially combines standard Weyl fermion fields and primitive (unphysical) boson fields:

$$\psi^r = \begin{pmatrix} \psi_b^r \\ \psi_f^r \end{pmatrix}$$

where ψ_b^r and ψ_f^r are both 2-component spinors, belonging to the same gauge representation with the same quantum numbers.

A stable vacuum then requires that the initial boson fields, whose excitations would have negative energy, be transformed into these three kinds of scalar-boson fields: the usual complex fields ϕ , auxiliary fields F , and real fields φ of a new kind.

The requirement of a stable vacuum thus imposes Lorentz invariance, and also immediately breaks the initial susy.

The predictions of the present theory include (1) the dark matter candidate of our previous papers, (2) many new fermions with masses not far above 1 TeV, and (3) the full range of superpartners with a modified phenomenology.

The Higgs mass-squared is still protected from quadratic divergences due to radiative corrections.

It is also possible to achieve grand unification of coupling constants.

The lightest susy partner is still a (subdominant) dark matter particle.

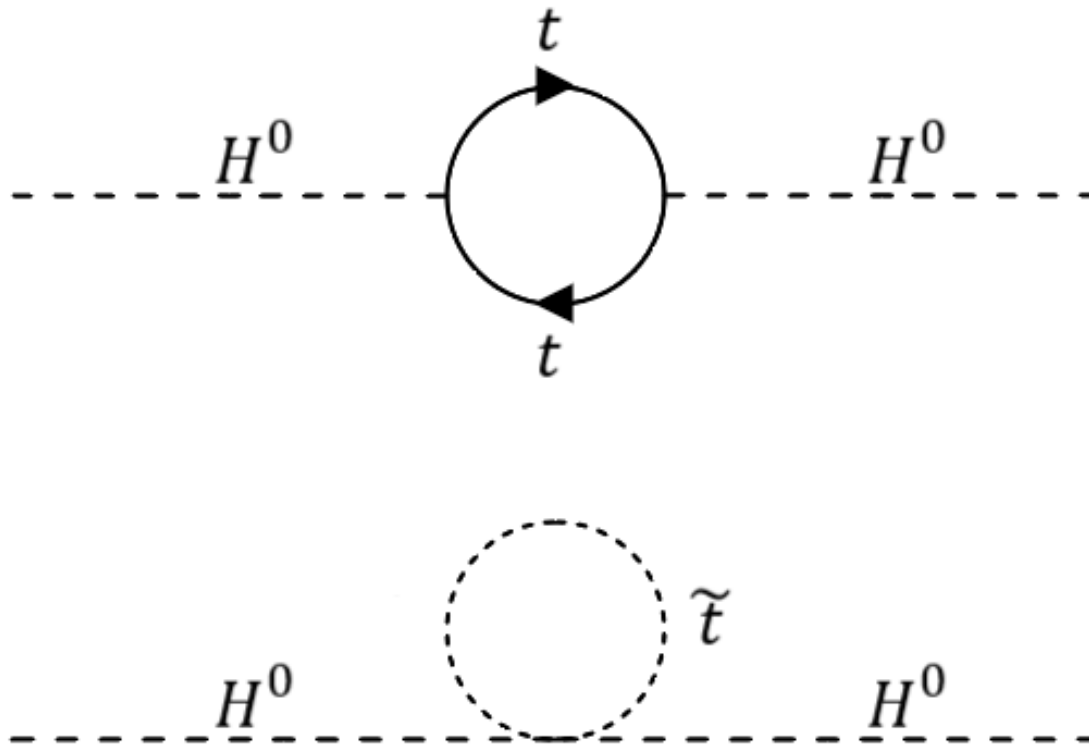

Figure by Bailey Tallman.

All the interactions of the new real scalar boson fields ϕ_α turn out to be second-order, after the arguments of arXiv:2307.04255.

Again, the Higgs mass is still protected from a linear divergence, coupling-constant unification can be achieved, and the LSP can still contribute to the dark matter (in a multicomponent scenario).

But cross-sections will be reduced and experimental signatures changed for both superpartners and our non-supersymmetric dark matter WIMP.

$$\begin{aligned}\overline{\mathcal{L}}_\alpha^{QCD} &= -\frac{g_s^2}{6} \varphi_\alpha^\dagger \mathcal{A}^{\mu i} \mathcal{A}_\mu^i \varphi_\alpha && \text{gluon} \\ \overline{\mathcal{L}}_\alpha^{EM} &= -(Qe)^2 \varphi_\alpha^\dagger \bar{A}^\mu \bar{A}_\mu \varphi_\alpha && \text{photon} \\ \overline{\mathcal{L}}_\alpha^W &= -\frac{g^2}{2} \varphi_\alpha^\dagger W^{+\mu} W_\mu^- \varphi_\alpha && W^\pm \\ \overline{\mathcal{L}}_\alpha^Z &= -\frac{g_Z^2}{4} \varphi_\alpha^\dagger Z^\mu Z_\mu \varphi_\alpha && Z^0 \\ \overline{\mathcal{L}}_\alpha^H &= -y_\alpha^2 \varphi_\alpha H^\dagger H \varphi_\alpha && \text{Higgs}\end{aligned}$$

In addition to the three *physical* implications of supersymmetry listed above, a fourth motivation has been *aesthetic*: the mathematical beauty of conventional supersymmetry (SUSY), with a super-Poincaré algebra where

$$\{Q_\alpha, \bar{Q}_{\dot{\beta}}\} = (\sigma^\mu)_{\alpha\dot{\beta}} P_\mu ,$$

and the elegance of its extensions up to supergravity, string theory, and beyond.

However, Nature is not required to respect human aesthetic preferences, and we are now at a point where there is considerable skepticism about the the viability of any version of supersymmetry.

Some skepticism was already being expressed 25 years ago, even by speakers at supersymmetry conferences (as witnessed by the present speaker), but the lack of evidence for SUSY is now often perceived to represent a crisis in fundamental physics.

In addition to this tension of SUSY with experiment, there are also theoretical impediments. For example, breaking SUSY is a difficult problem for which no convincing solution has been found.

The difficulty ultimately results from the relation above, which implies that a mechanism for breaking conventional SUSY must *INCREASE* the energy, in contrast to the normal symmetry breakings elsewhere in physics which *LOWER* the energy.

Flavor-changing neutral currents have also long been a threat to supersymmetry theories.

In the present theory these difficulties are either absent or diminished.

In the present theory, many conventional processes (or Feynman diagrams) for producing superpartners are eliminated – since a vertex involving a sfermion must join two sfermion lines and two boson lines, as in the Lagrangian shown before. Cross-sections are then reduced.

In addition, sfermions cannot decay, since a process with a single initial sfermion must result in a single outgoing sfermion plus other particles.

The experimental signatures are then very different from those that have been intimately built into the triggers, cuts, statistical analyses, and interpretations in past searches for SUSY, as the data from hundreds of millions of collisions per second are reduced to manageable sets.

Again, and most dramatically, a sfermion can only be detected via hadronization with *second-order* electromagnetic, strong, weak, and Higgs interactions.

In addition to no decays for sfermions, many of the decay processes for bosinos (gluinos, neutralinos, and charginos) involving virtual sfermions are drastically modified.

For example, these processes, and most of those in the following slides, are not allowed for squark production and for squark and gluino decays.

Cross-sections for production, decay, and detection are then reduced, and experimental signatures assumed for detection and analysis are modified.

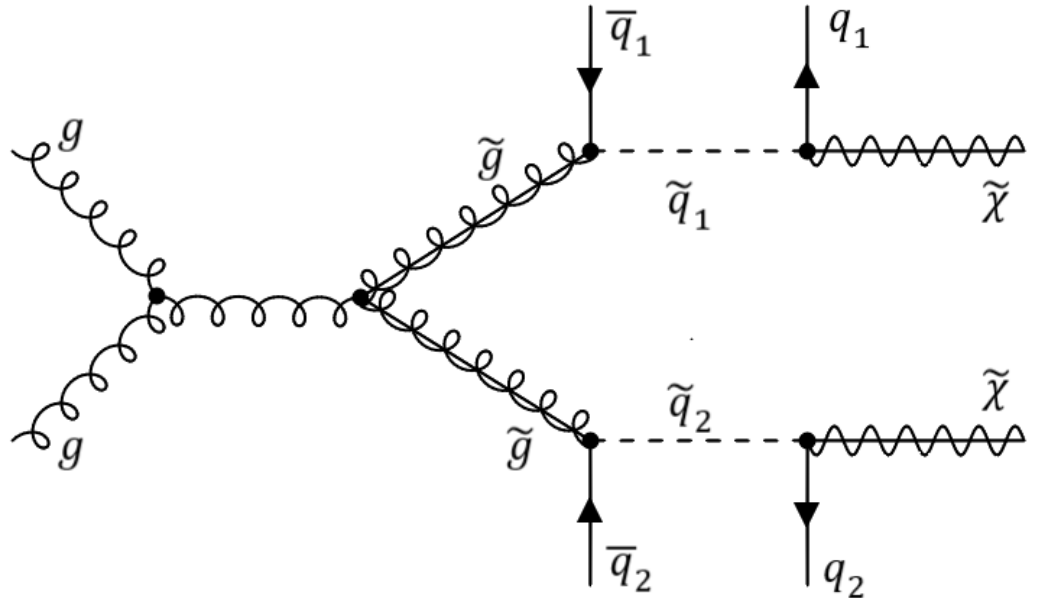
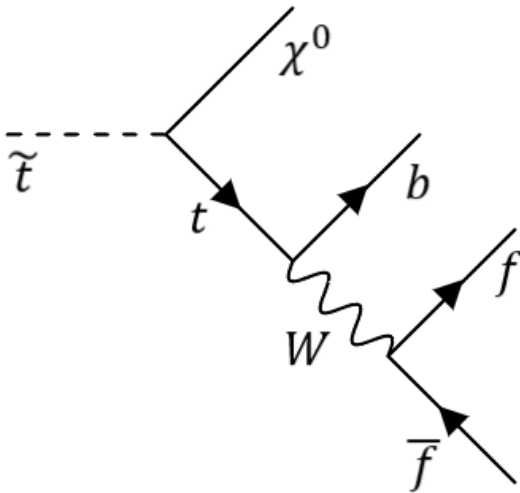
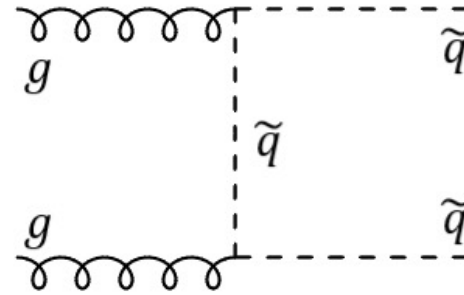
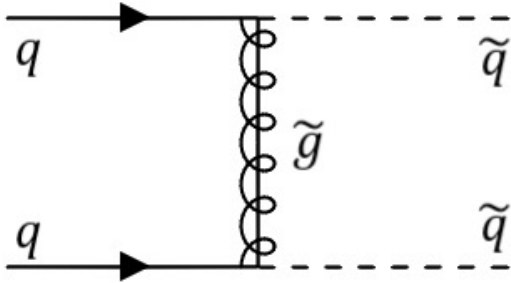

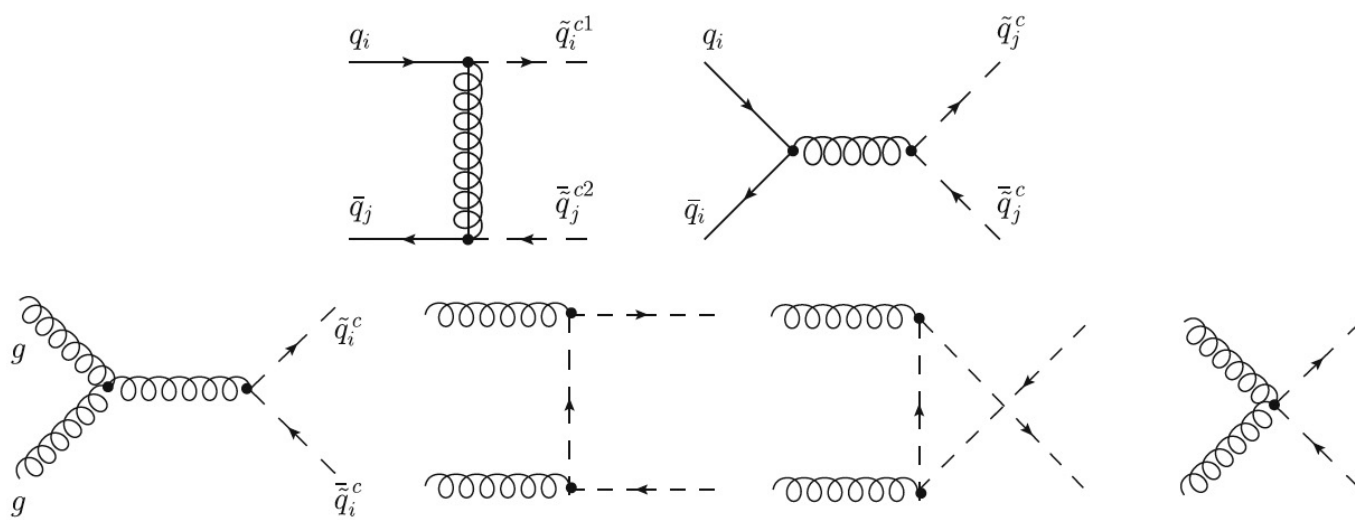
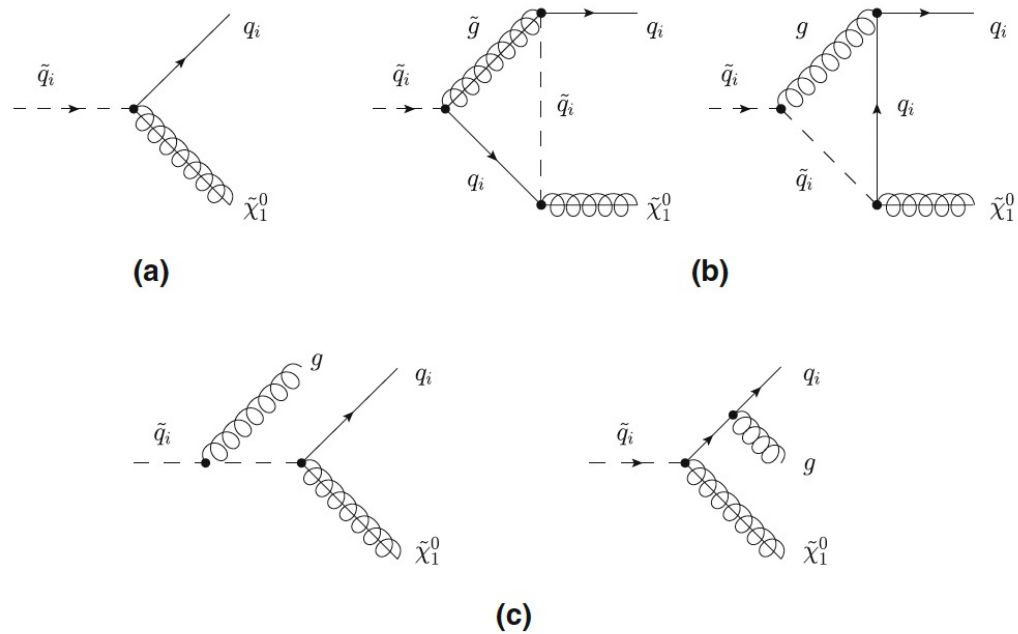

Fig. 1 Feynman diagrams contributing to squark–antisquark production at LO

Fig. 5 Feynman diagrams contributing to the decay $\tilde{q}_i \rightarrow q_i \tilde{\chi}_1^0$ at LO (a) and at NLO: virtual corrections (b) and real gluon radiation (c)



Some gluino decays in
 H. Baer and X. Tata, *Weak Scale Supersymmetry*
 that do not occur in the present theory

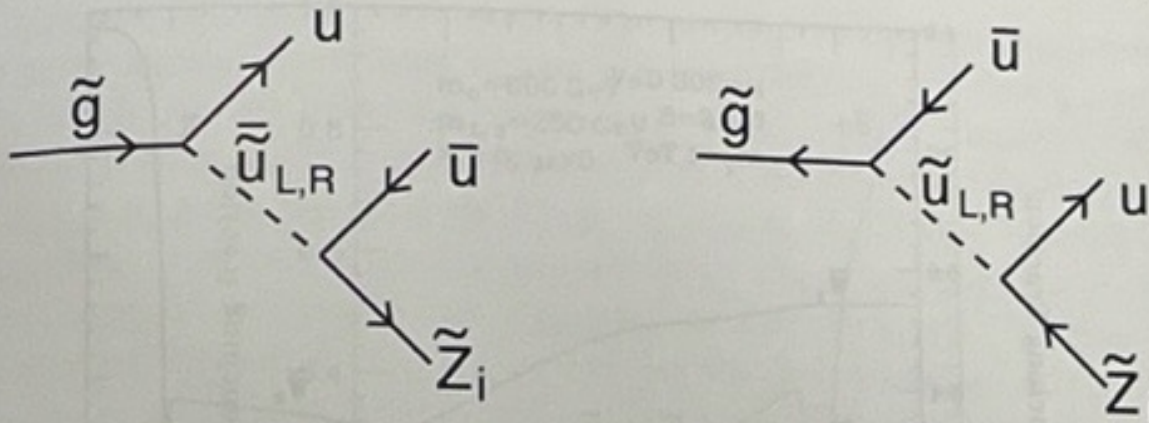

Figure 13.2 Feynman diagrams contributing to the decay $\tilde{g} \rightarrow u\bar{u}\tilde{Z}_i$. Decays to other flavors of squarks occur via similar diagrams.

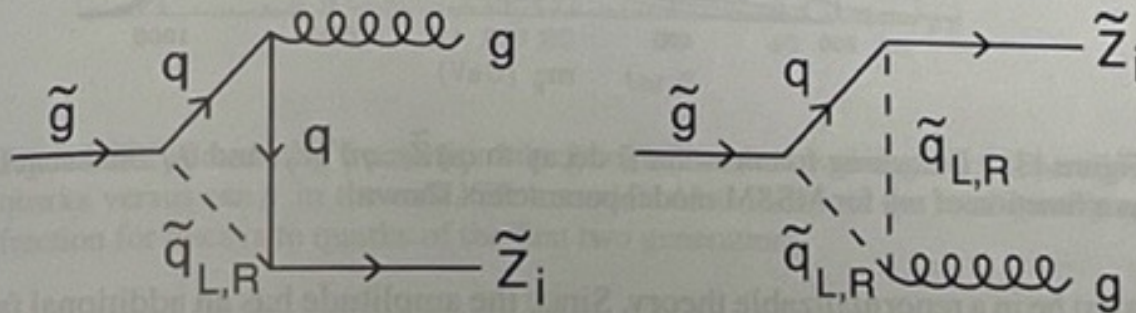

Figure 13.3 Feynman diagrams contributing to the decay $\tilde{g} \rightarrow g\tilde{Z}_i$. Since the gluino and the neutralino are Majorana particles, these same diagrams but with reversed arrows also contribute to the amplitude. This corresponds to distinct contractions in the evaluation of the decay matrix element.

Some other gluino decays in
H. Baer and X. Tata, *Weak Scale Supersymmetry*
that do not occur in the present theory

13.1 Decay of the gluino

343

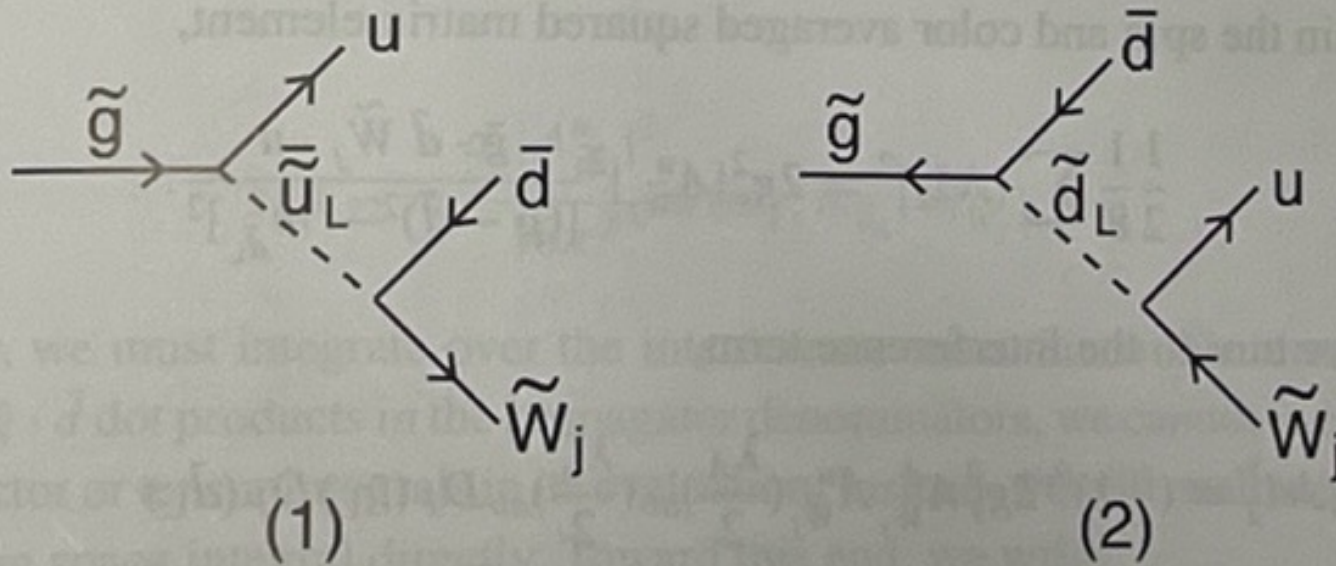

Figure 13.1 Feynman diagrams contributing to the decay $\tilde{g} \rightarrow u\bar{d}\tilde{W}_j$.

The same theory leads to a very promising dark matter candidate, as discussed in our previous papers, including [1-4]:

We estimate the WIMP-nucleon cross-section to be $\sim 10^{-48}$ cm².

Both XENONnT and LZ anticipate a sensitivity that extends to 1.4×10^{-48} cm². So direct detection may be possible within $\sim 5-15$ years.

With a collider production cross-section (via vector boson fusion) calculated to be 17 femtobarns [by Bailey Tallman], this particle may be observable at the high-luminosity LHC in $\sim 12-15$ years.

Its mass and annihilation cross-section are consistent with analyses of the gamma rays observed by Fermi-LAT and antiprotons observed by AMS-02, interpreted as evidence of dark matter annihilation, so it may already have been detected.

[1] Reagan Thornberry, Maxwell Throm, John Killough, Dylan Blend, Michael Erickson, Brian Sun, Brett Bays, Gabe Frohaug, and Roland E. Allen, "Experimental signatures of a new dark matter WIMP", EPL (European Physics Letters), 34, 49001 (2021), arXiv:2104.11715 [hep-ph].

[2] Caden LaFontaine, Bailey Tallman, Spencer Ellis, Trevor Croteau, Brandon Torres, Sabrina Hernandez, Diego Cristancho Guerrero, Jessica Jaksik, Drue Lubanski, and Roland Allen, "A Dark Matter WIMP That Can Be Detected and Definitively Identified with Currently Planned Experiments", Universe 7, 270 (2021), arXiv:2107.14390 [hep-ph]

[3] Bailey Tallman, Alexandra Boone, Caden LaFontaine, Trevor Croteau, Quinn Ballard, Sabrina Hernandez, Spencer Ellis, Adhithya Vijayakumar, Fiona Lopez, Samuel Apata, Jehu Martinez, and Roland Allen, proceedings of ICHEP 2022, <https://pos.sissa.it/414/>, DOI 10.22323/1.414.0988], arXiv:2210.05380 [hep-ph].

[4] Bailey Tallman, Alexandra Boone, Adhithya Vijayakumar, Fiona Lopez, Samuel Apata, Jehu Martinez, and Roland Allen, Letters in High Energy Physics LHEP-342 (2023), arXiv:2210.15019 [hep-ph].

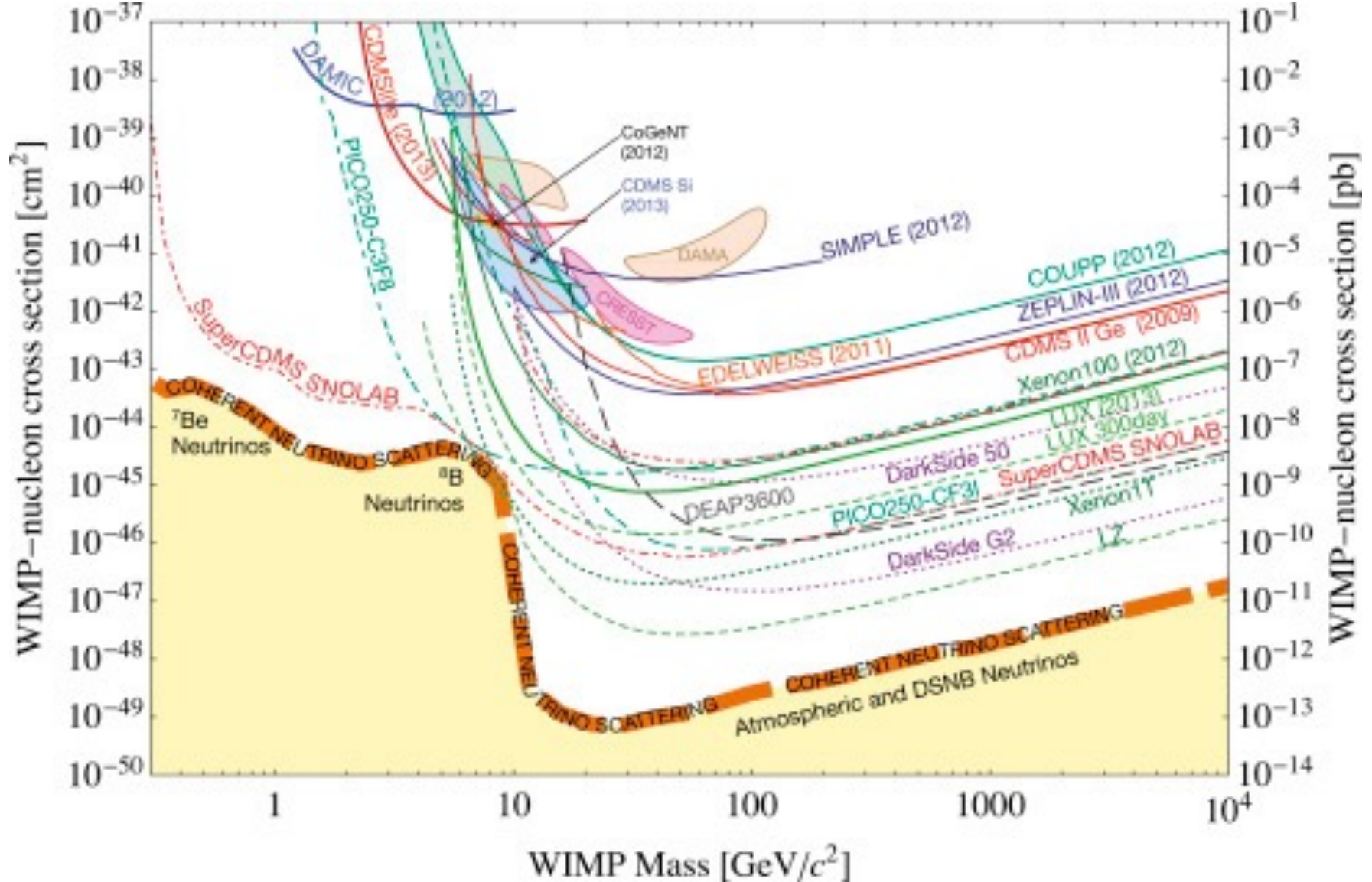

A cross-section for direct detection $\sim 10^{-48} \text{ cm}^2$ at $70 \text{ GeV}/c^2$ is above the neutrino floor (or fog) and may be accessible to LZ and XENONnT, plus ultimately PandaX and other experiments.

If the mass of h^0 were above the mass of a W boson, annihilation into real W and Z pairs would have a large cross-section, and result in a severe underabundance of dark matter.

If the mass of h^0 were far below the mass of a W boson, annihilation into a real W or Z and a virtual one would have a small cross-section, and would result in a severe overabundance of dark matter.

But for a mass of about 70 GeV the relic abundance is in agreement with observation, as determined in MicrOMEGAs calculations by Bailey Tallman.

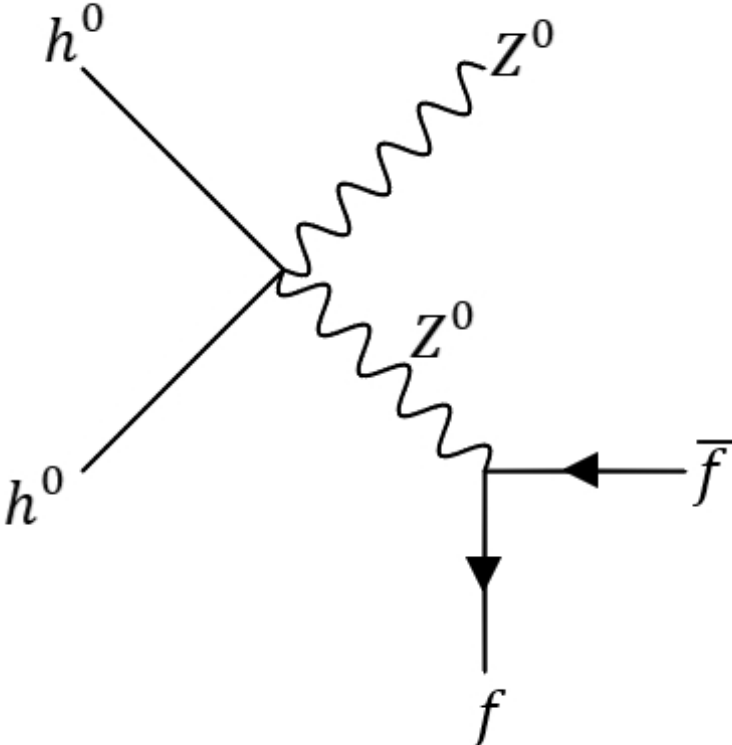
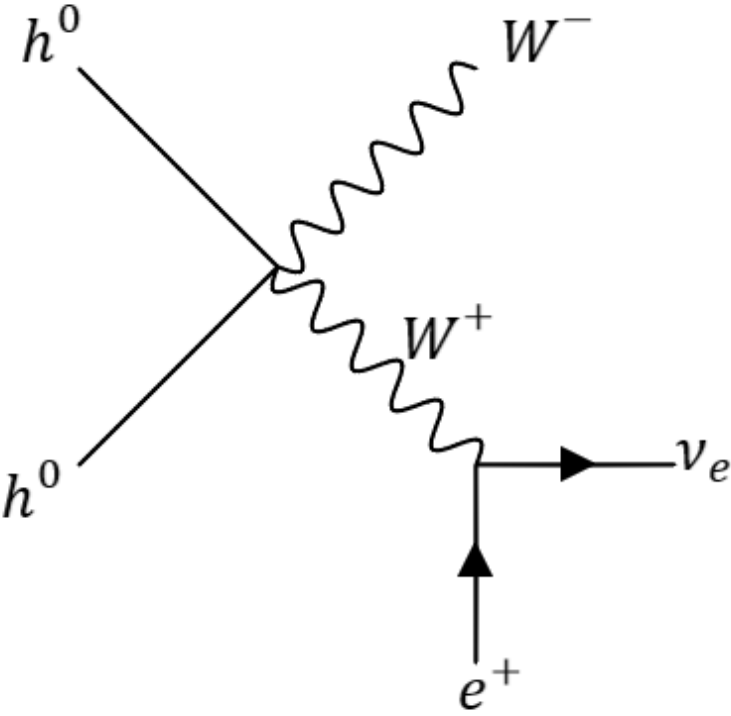

Three of the space-based studies of astrophysical phenomena:

Fermi-LAT



AMS-02



Planck

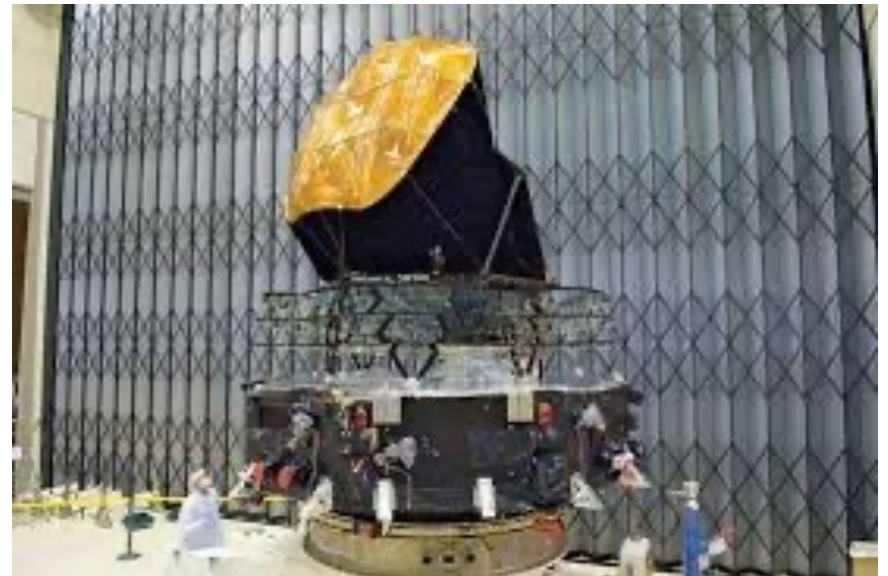

Christopher Karwin, Simona Murgia, Tim M. P. Tait, Troy A. Porter, and Philip Tanedo, Phys. Rev. D 95, 103005 (2017), arXiv:1612.05687 [hep-ph]:

“The center of the Milky Way is predicted to be the brightest region of γ -rays generated by self-annihilating dark matter particles. Excess emission about the Galactic center above predictions made for standard astrophysical processes has been observed in γ -ray data collected by the Fermi Large Area Telescope.

It is well described by the square of a Navarro, Frenk, and White dark matter density distribution. Although other interpretations for the excess are plausible, the possibility that it arises from annihilating dark matter is valid.”

“... its spectral characteristics favor a dark matter particle with a mass in the range approximately from 50 to 190 (10 to 90) GeV ... for pseudoscalar (vector) interactions.”

Rebecca K. Leane and Tracy R. Slatyer, “Revival of the Dark Matter Hypothesis for the Galactic Center Gamma-Ray Excess”, Phys. Rev. Lett. 123, 241101 (2019), arXiv:1904.08430 [astro-ph.HE]:

“... we conclude that dark matter may provide a dominant contribution to the GCE after all.”

Intriguing results from two careful analyses of AMS-02 observations of antiprotons and Fermi-LAT observations of gamma rays from the Galactic Center

Ilias Cholis, Tim Linden, and Dan Hooper, “A Robust Excess in the Cosmic-Ray Antiproton Spectrum: Implications for Annihilating Dark Matter”, Phys. Rev. D 99, 103026 (2019); arXiv:1903.02549 [astro-ph.HE]:

“This excess is well fit by annihilating dark matter particles, with a mass and cross section in the range of $m_\chi \approx 46\text{-}94$ GeV ...”

“... it is particularly intriguing that the range of dark matter models that can accommodate the antiproton excess is very similar to those which could generate the excess of GeV-scale gamma rays observed from the Galactic Center...”

Alessandro Cuoco, Jan Heisig, Lukas Klamt, Michael Korsmeier, and Michael Krämer, “Scrutinizing the evidence for dark matter in cosmic-ray antiprotons”, Phys. Rev. D 99, 103026 (2019); arXiv:1903.01472 [astro-ph.HE]:

“... strong limits on heavy DM have been derived from global CR fits. At the same time, the data have also revealed a tentative signal of DM, corresponding to a DM mass of around 40–130 GeV ...”

“This signal, if confirmed, is compatible with a DM interpretation of the Galactic center γ -ray excess ...”

The inferred masses and cross-sections in the analyses are consistent with those for the present dark matter candidate – e.g., a mass about 70 GeV/c².

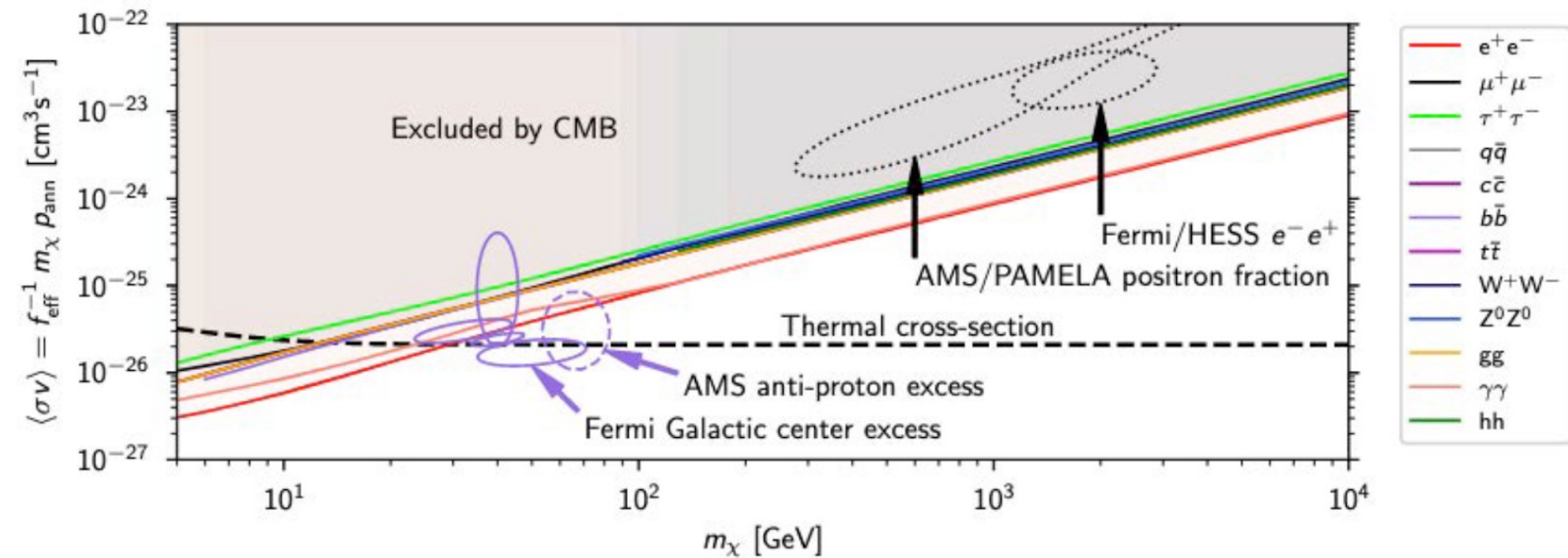

“*Planck* 2018 constraints on DM mass and annihilation cross-section. Solid straight lines show joint CMB constraints on several annihilation channels (plotted using different colours) ... We also show the 2σ preferred region suggested by the AMS proton excess (dashed ellipse) and the Fermi Galactic centre excess according to four possible models with references given in the text (solid ellipses) ... We additionally show the 2σ preferred region suggested by the AMS/PAMELA positron fraction and Fermi/H.E.S.S. electron and positron fluxes ... Assuming a standard WIMP-decoupling scenario, the correct value of the relic DM abundance is obtained for a ‘thermal cross-section’ given as a function of the mass by the black dashed line.”

“CMB anisotropies are sensitive to energy injection in the intergalactic medium that could be a consequence, for example, of dark-matter (DM) annihilation ... The current CMB sensitivity to the annihilation cross section of weakly-interacting massive particles (WIMPs) is competitive with and complementary to that of indirect DM search experiments.”

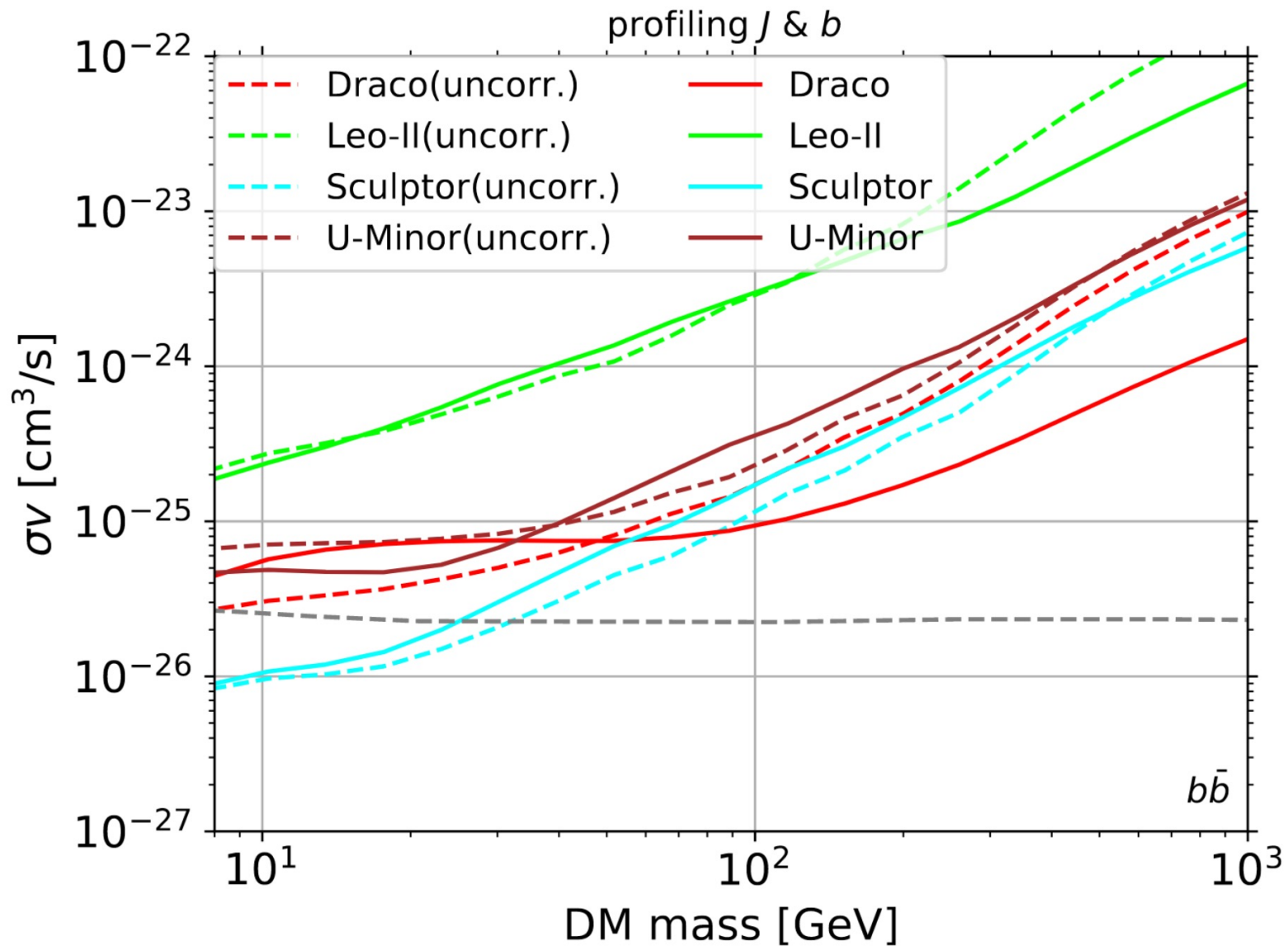

Our calculated annihilation cross-section of $\langle \sigma_{ann} v \rangle \approx 1.2 \times 10^{-26}$ cm³/s at 70 GeV is consistent with the current limits: Alexandre Alvarez, Francesca Calore, Anna Genina, Justin Read, Pasquale Dario Serpico, and Bryan Zaldivar, “Dark matter constraints from dwarf galaxies with data-driven J-factors”, JCAP 09, 004 (2020), arXiv:2002.01229 [astro-ph.HE]. 22

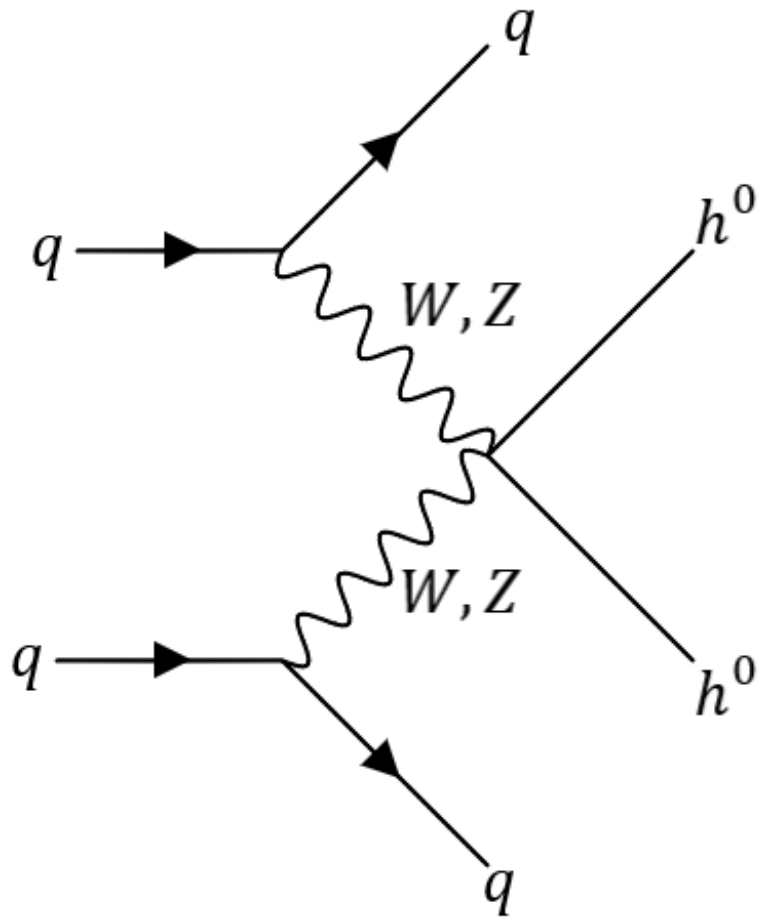

Vector boson fusion appears to be the best prospect for collider detection, with the cross-section of 17 fb [calculated by Bailey Tallman] probably within reach of the high-luminosity LHC if it can attain 3000 fb^{-1} .

The signature is $\geq 140 \text{ GeV}$ of missing energy and two jets.

Plots below and MadGraph calculations by Bailey Tallman.
The mass of 70 GeV for our dark matter WIMP was also determined by Bailey Tallman,
by fitting to the observed dark matter abundance in MicrOMEGAs calculations.
Equivalent calculations for Higgs pair production are shown for comparison.

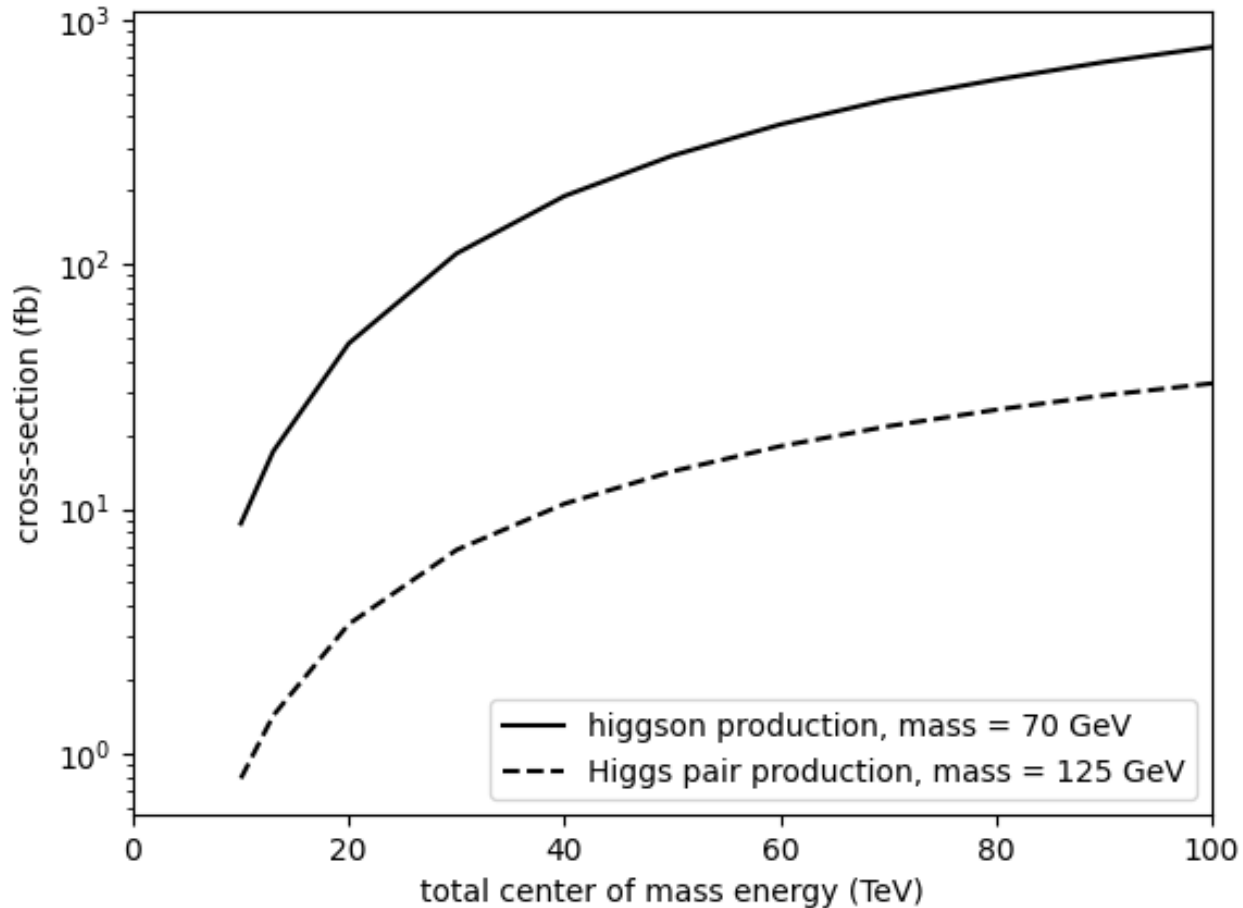

production of 70 GeV higgsone dark matter WIMP at proton collider

Plots below by Jehu Martinez, for production of our 70 GeV dark matter WIMP in a muon (or electron) collider, based on MadGraph calculations by Jehu Martinez, Aleksy Rodriguez, and Dario Ramirez-Pico. Feynman diagram by Aleksy Rodriguez.

polarized muon W cross-section

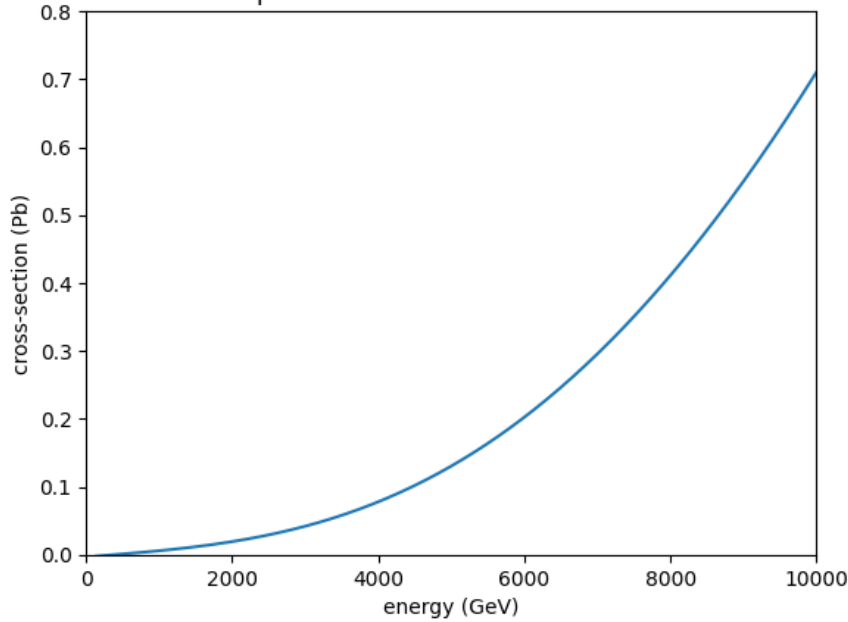

polarized muon Z cross-section

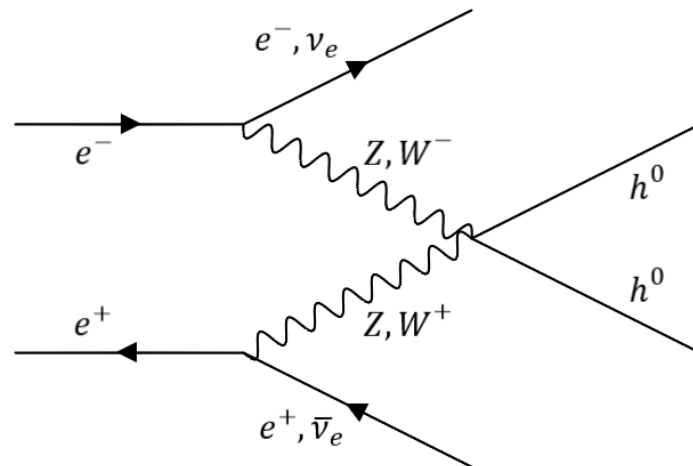
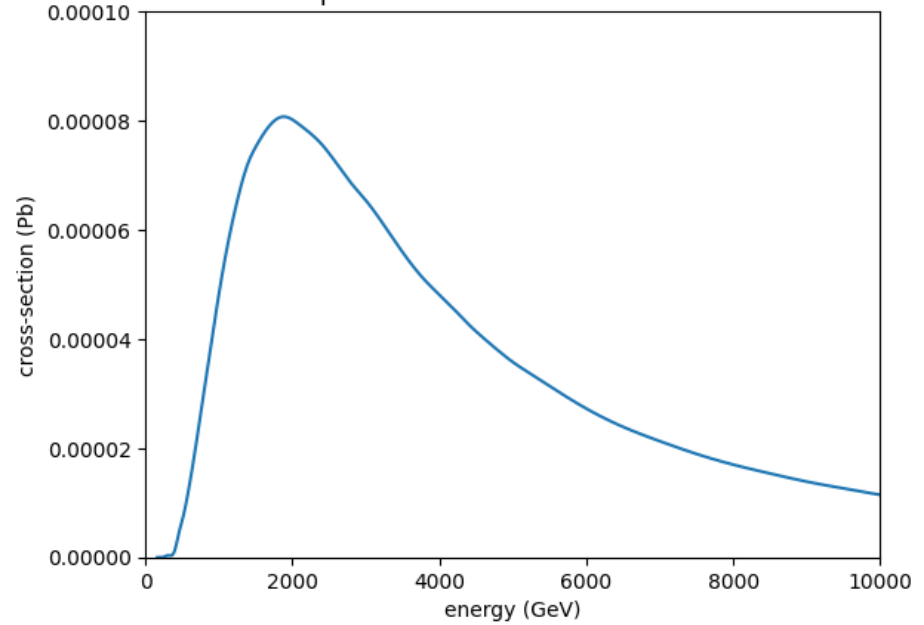

The history of spin 1/2 fermions begins with the discovery of the electron in 1897 by J. J. Thomson.

The history of spin 1 gauge bosons begins with the 1905 paper of Einstein which introduced the photon.

A spin 0 boson is something new (2012), and surprises may *again* lie ahead!

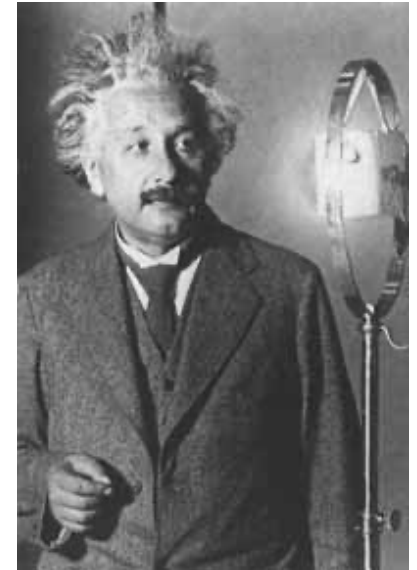
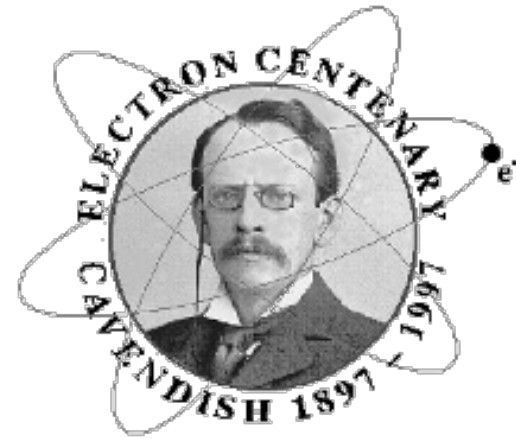

In the present theory
3 scalar boson sectors:

ϕ, F, φ

Thanks for your attention!

