



Recent Progress of The ePIC FECal

Weihu Ma

Fudan University
For the ePIC FECal Team
July 2, 2024



- ✓ High Level Summary of Scope
- ✓ High Level Input
- ✓ Choice of Technology
- ✓ Current Status
- ✓ FECal Consortia Structure, WBS
- ✓ Plans for Future
- ✓ Summary

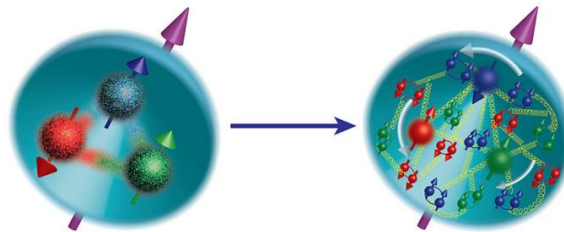

The Electron Ion Collider at BNL

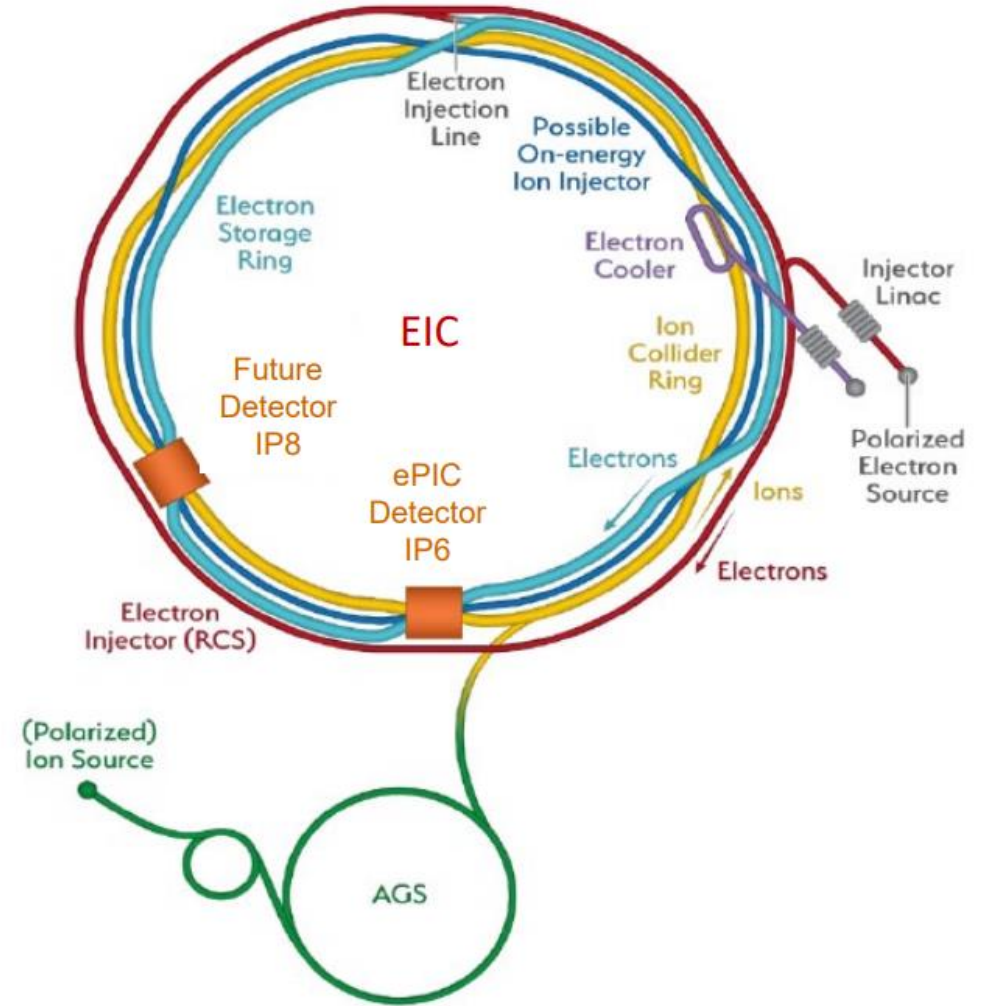

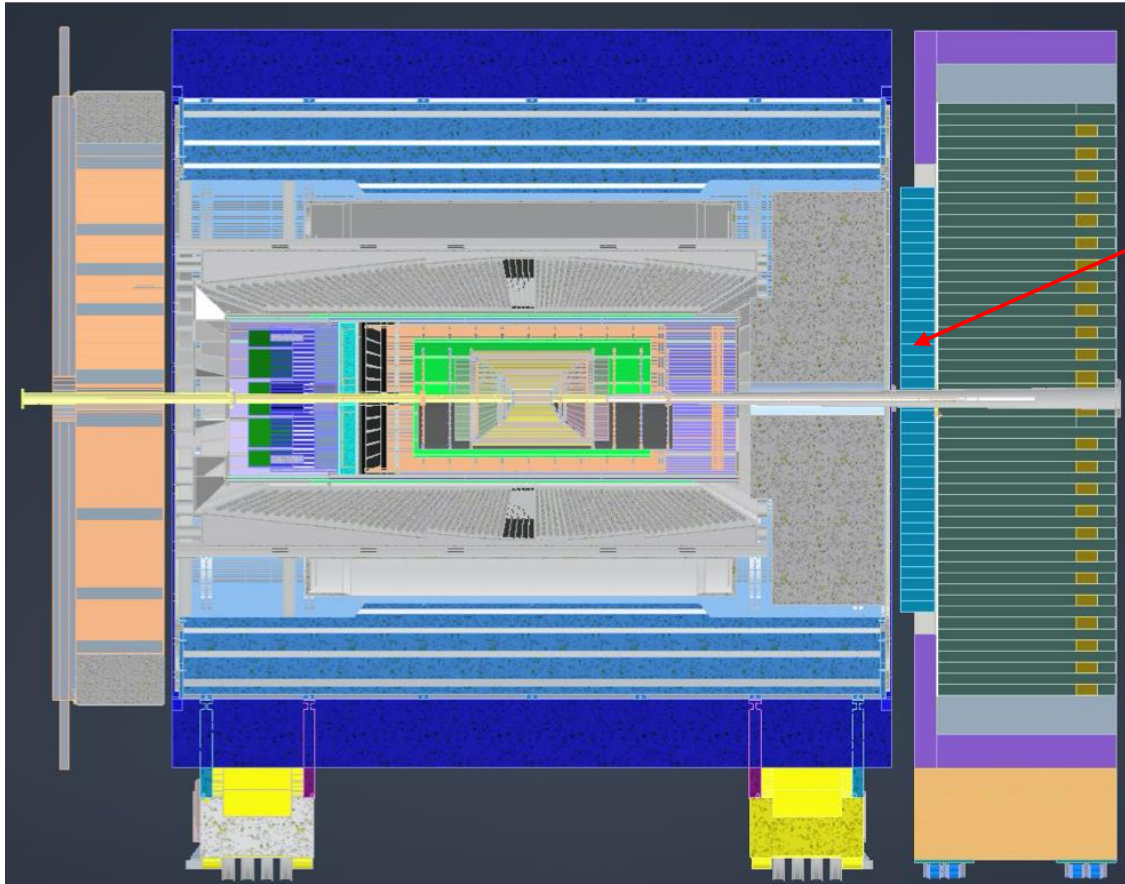

- Forward ECal is part of a Hadron Endcap
- Covers pseudo rapidity range ~ 1 to 4 (R_{in} 30 cm, R_{out} 173 cm)
- Integration length along Z - 30 cm
- Total weight ~ 20 tons
- Number of readout channels $\sim 15k$



- Yellow Report – desired energy resolution $10\%-12\%/\sqrt{E} \oplus 2\%$
- Yellow Report – good π^0/γ discrimination up to ~ 50 GeV
- Optimal reconstruction of jets (ECal +HCal (+ tracker))
- Readout must work in magnetic field, neutron fluxes up to 10^{12} n/cm².
- ECal must fit in limited space. (Small X_0)

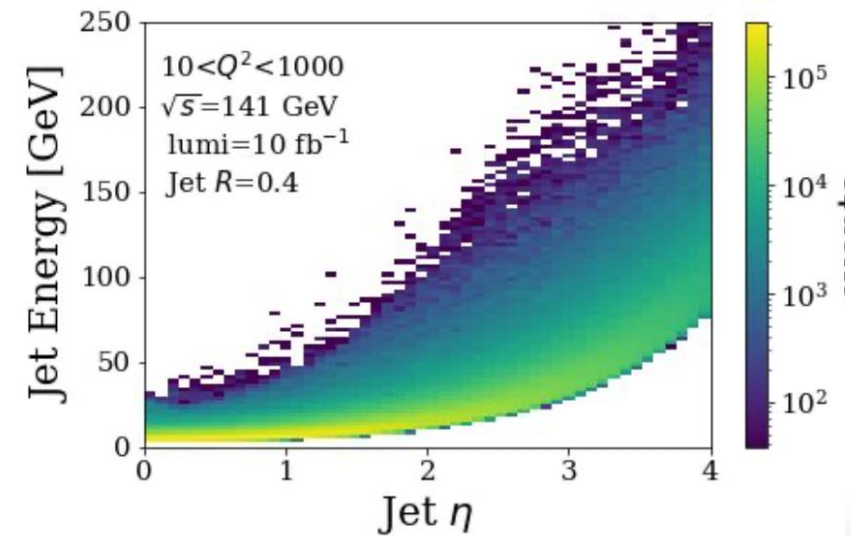
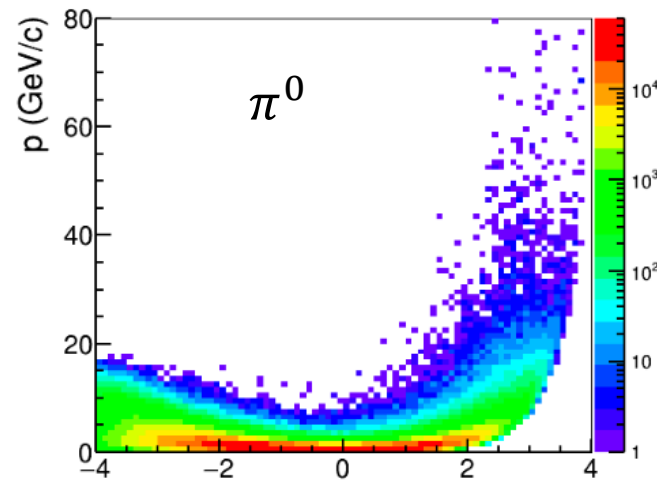
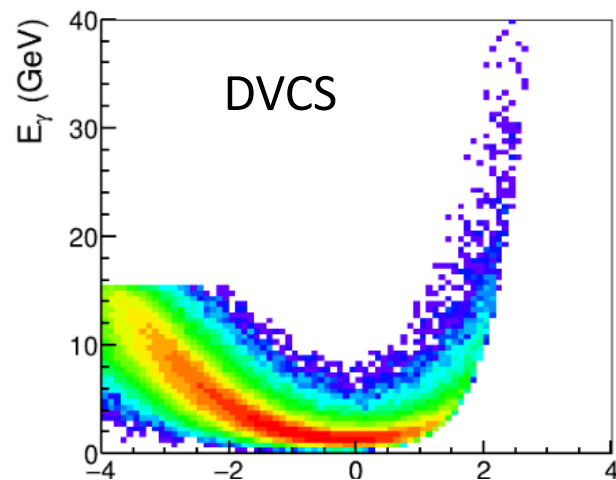



FECal is based on technology developed during generic EIC R&D and then used in the construction of sPHENIX EMCAL.

The FECal block design consists of scintillating fibers embedded in the absorber material, which is a matrix of tungsten powder infused with epoxy (W/SciFi).

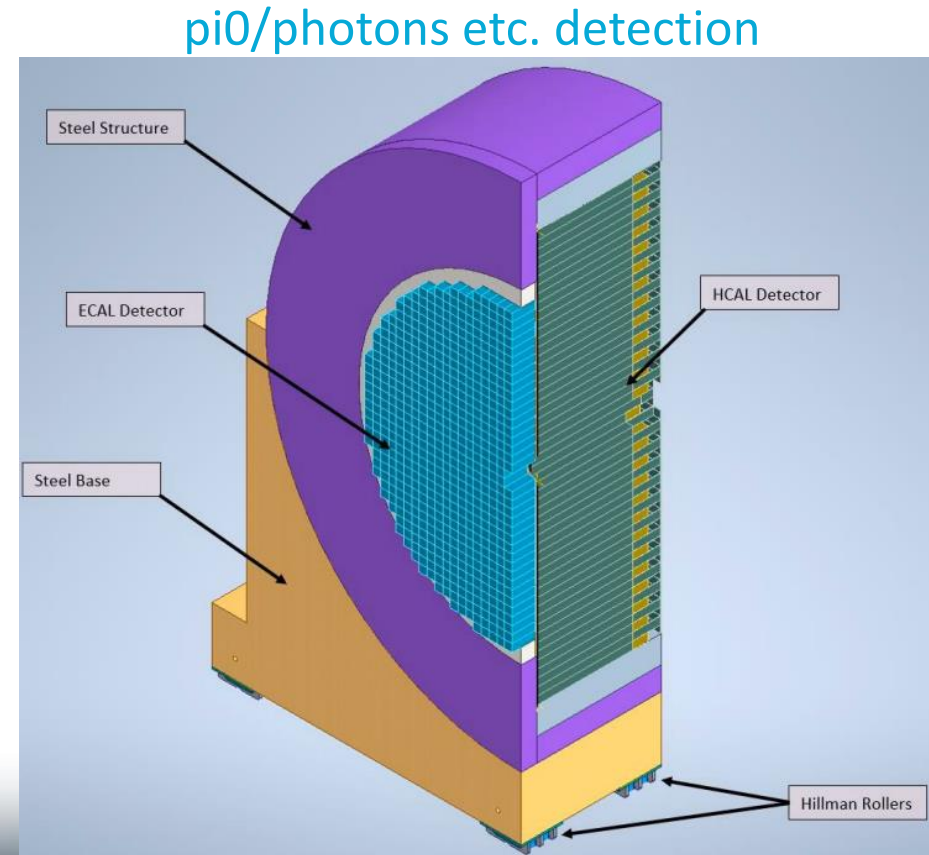
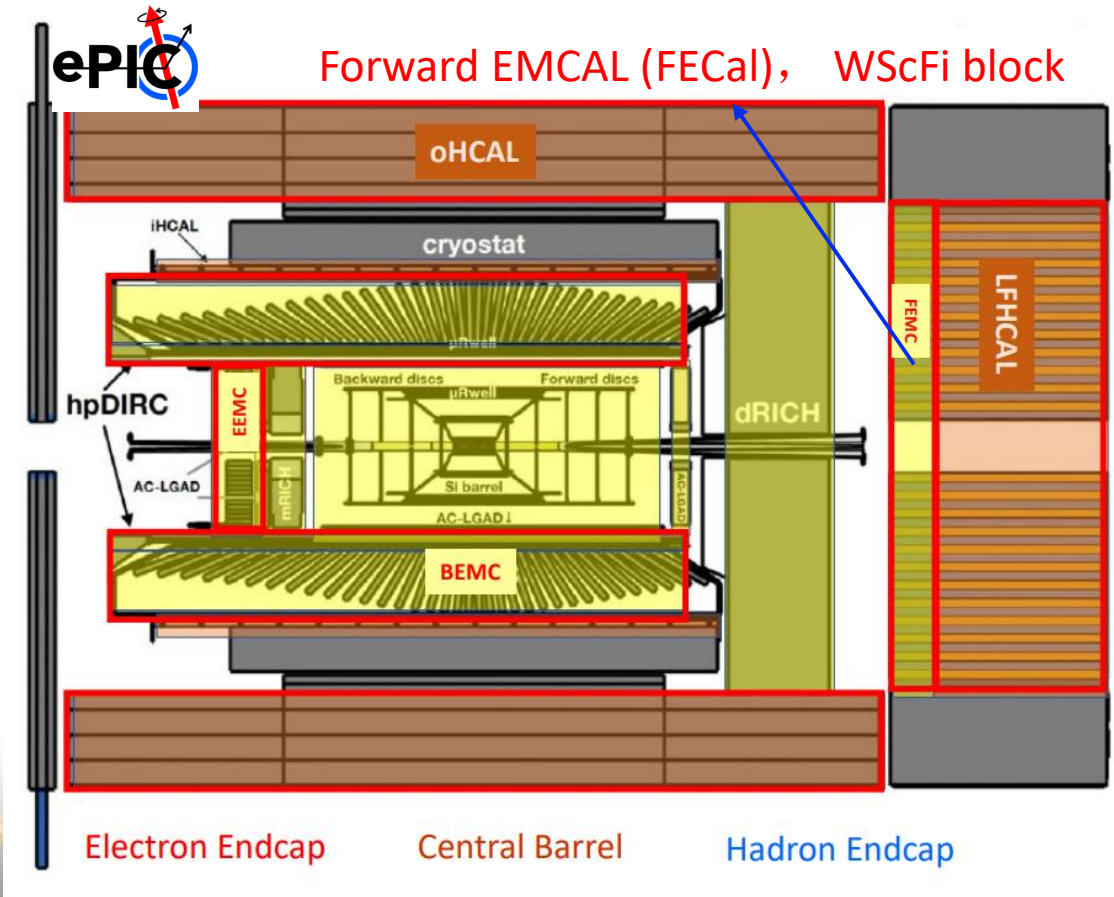



Tungsten Powder:

Tap density: $> 11.2 \text{ g/cm}^3$

Purity: $>99.9\%$, Fe, Co, Ni $<0.1\%$

Size: $90\sim 110\mu\text{m}$

EMCal block density: $\sim 9.6 \text{ g/cm}^3$

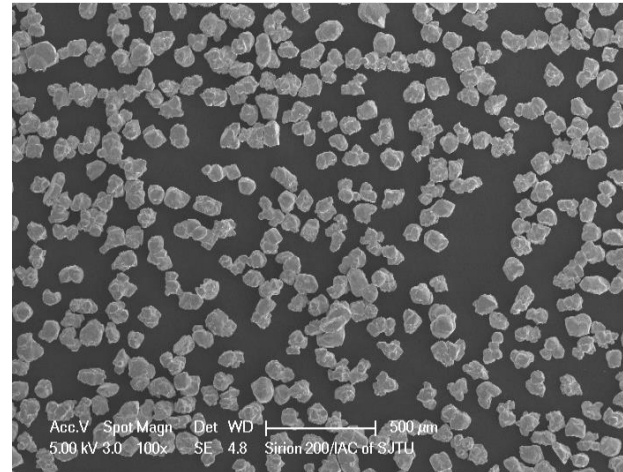

Epoxy

Long term stability

High shear strength

Safe

Cheap

✓ De Neef Denepox I-40

✓ BONDHUAJU

Scintillation Fibers:

Diameter: $0.47 \pm 0.01 \text{ mm}$

Emission peak: $430\sim 460 \text{ nm}$

Decay time: $2.5\sim 3.5 \text{ ns}$

Attenuation length: $>4\text{m}$

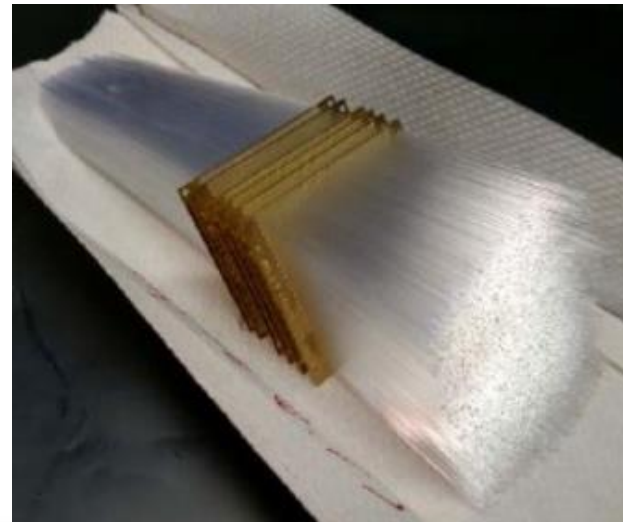



In the middle of July 2023 we are expecting third and final batch of fibers from Luxium (former Bicron, St.Gobain) We are expecting Luxium fibers will meet our requirements. Kuraray already there.

Measurements at UCLA of LY for Luxium and Kuraray fibers

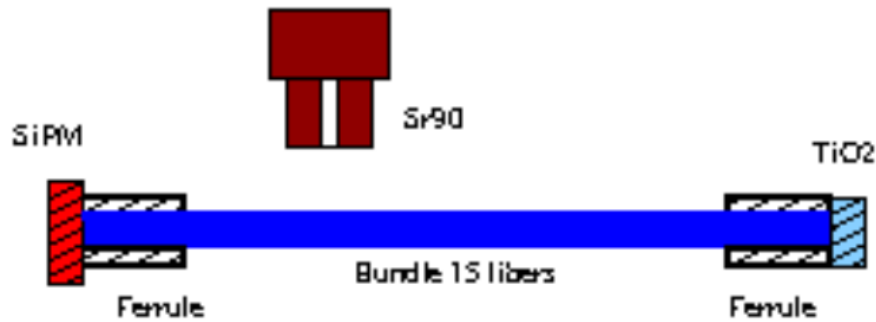

Bundle of fibers readout by same SiPMs, far end with TiO2 diffuser, activated with Sr90 source

Kuraray vs SG, fibers 0.47 mm, Current vs Position

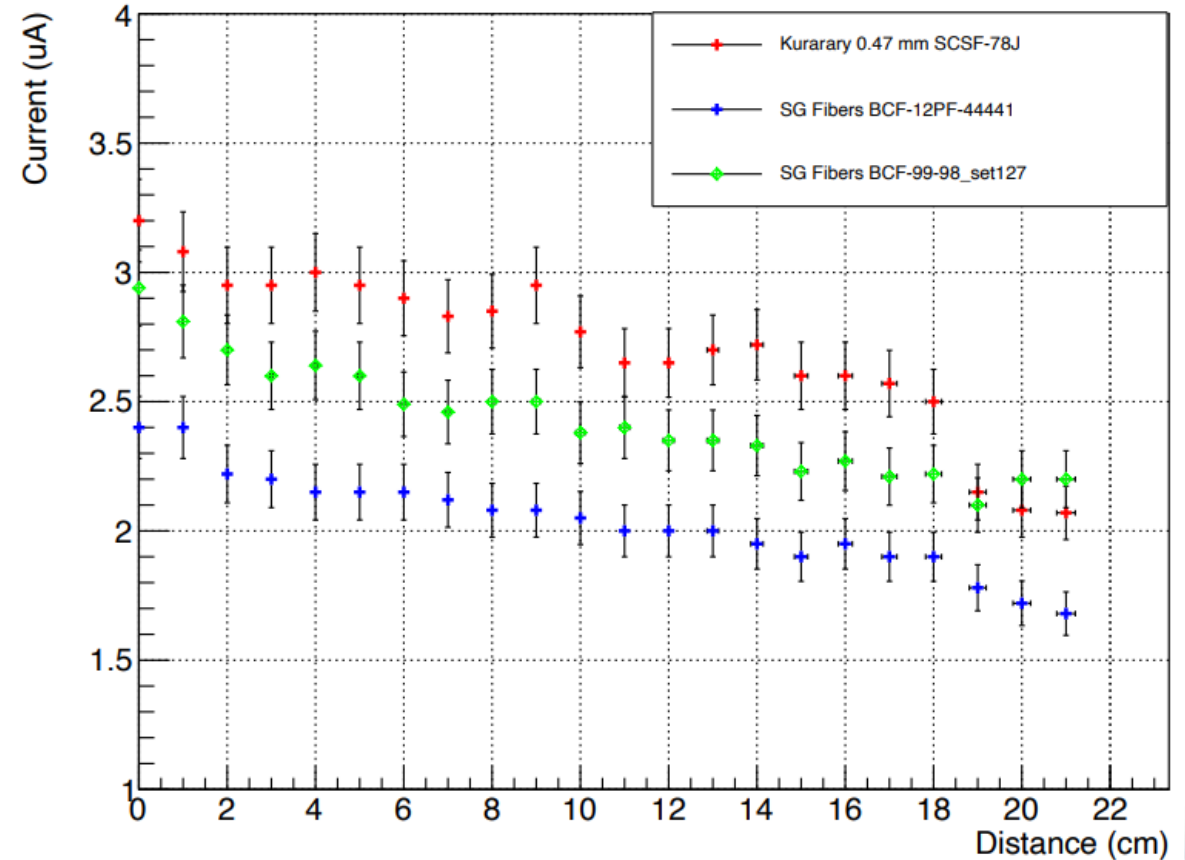



ePIC-FECal block: Fiber filling



- Tools for fiber filling are ready.
- It works well both for meshes and filling.
- ~1 hour filling time.

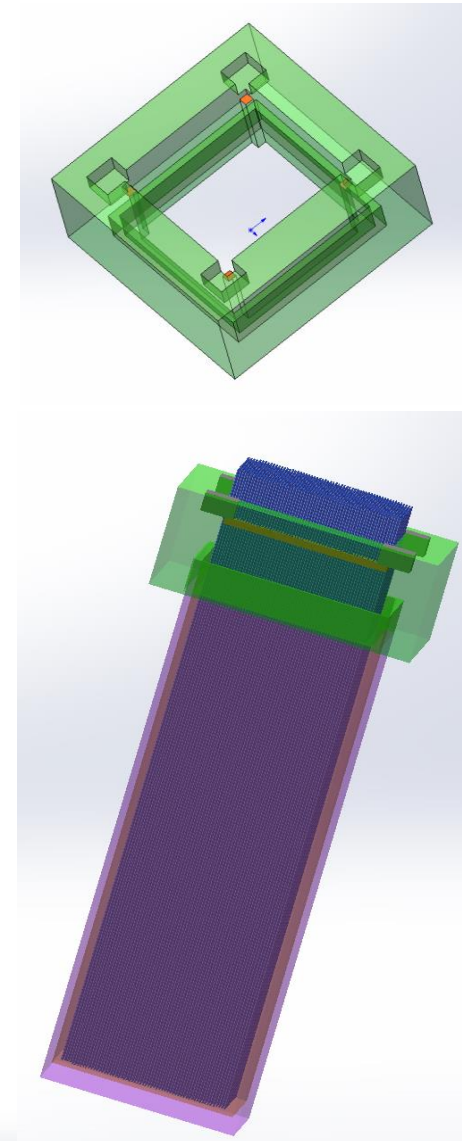
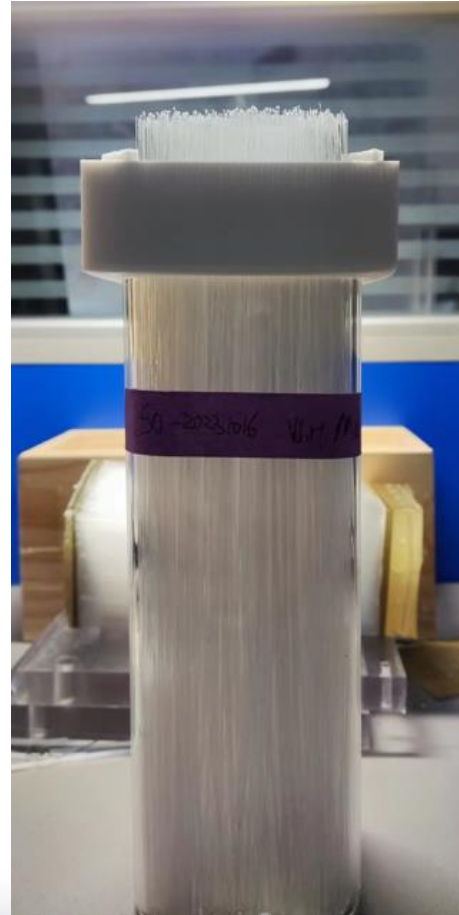

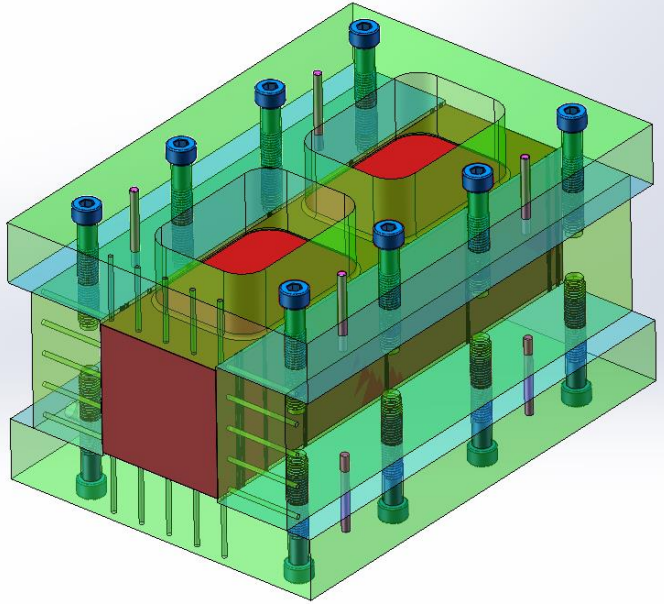

- Tools (screws, dowels, capillary tube, etc) for mold assembly are ready at Fudan.
- It works well for putting the fiber set in the mold.
- New molds are ready.

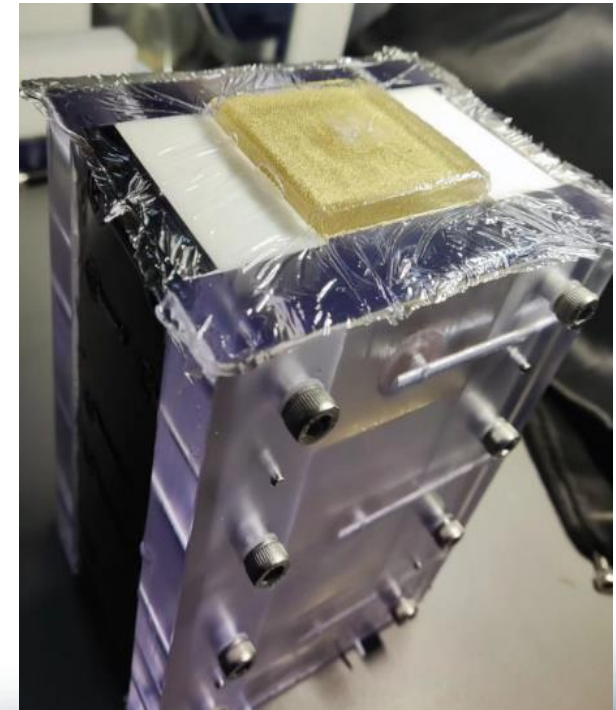
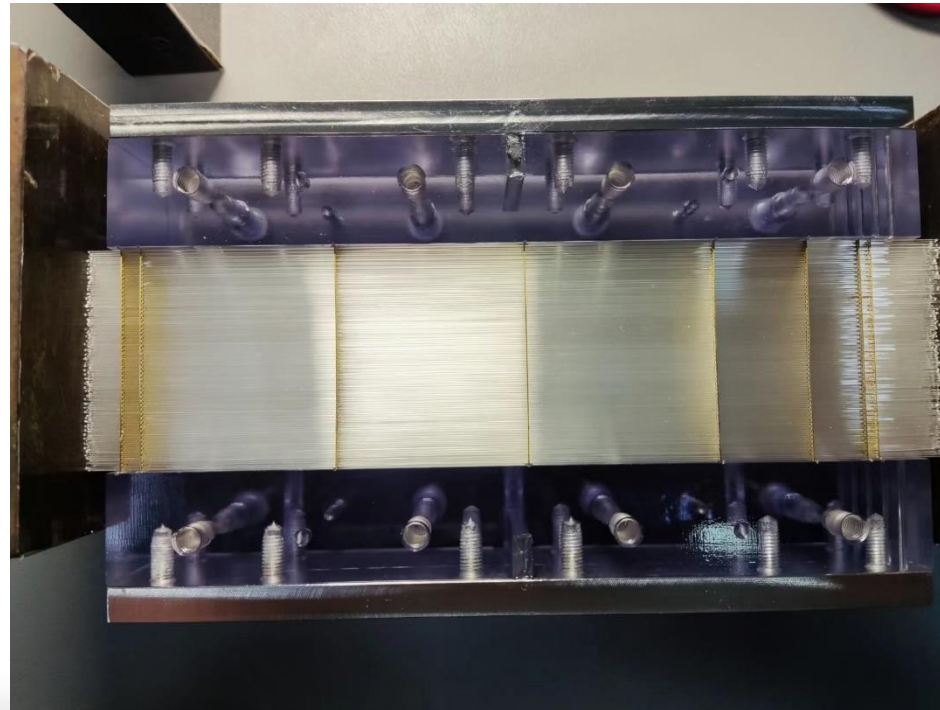



ePIC-FECal block: Epoxy flow test at Fudan



Injection holder

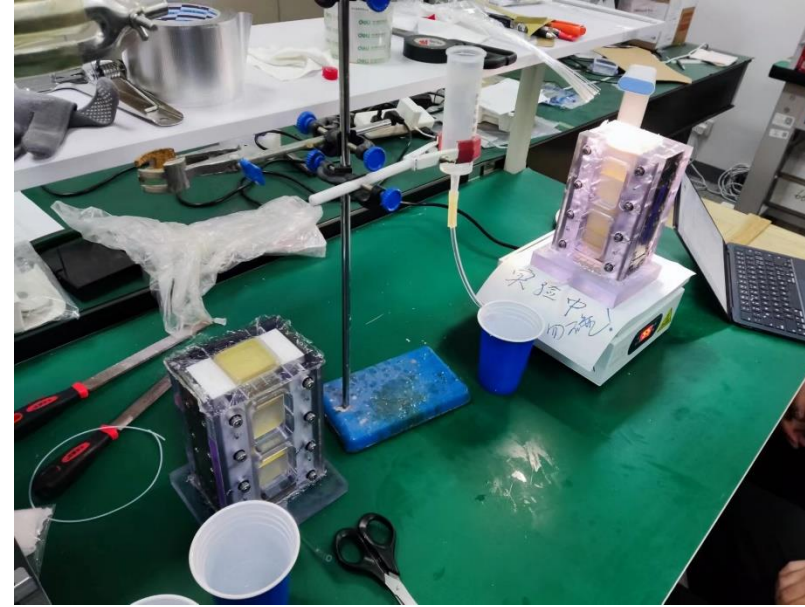
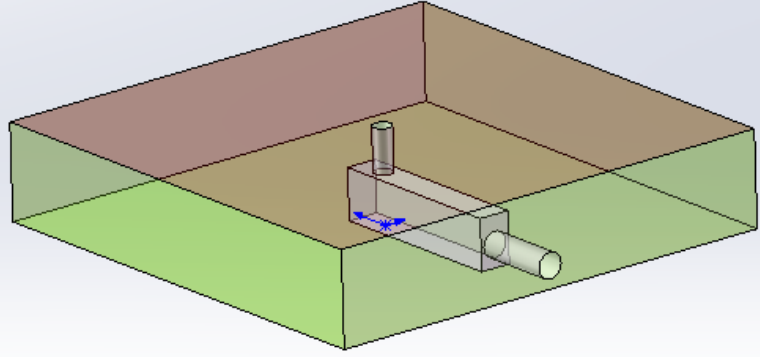

Get rid of bubbles:
Warm and flow slowly

preheating table

- 017吸棒器
- 直尖镊子
- 弯尖镊子

标配+3件套

品牌	邦远	温度范围	0~400°C
型号	BY2020	加热铝板	200X200mm
功率	700W	外形	防烫包边

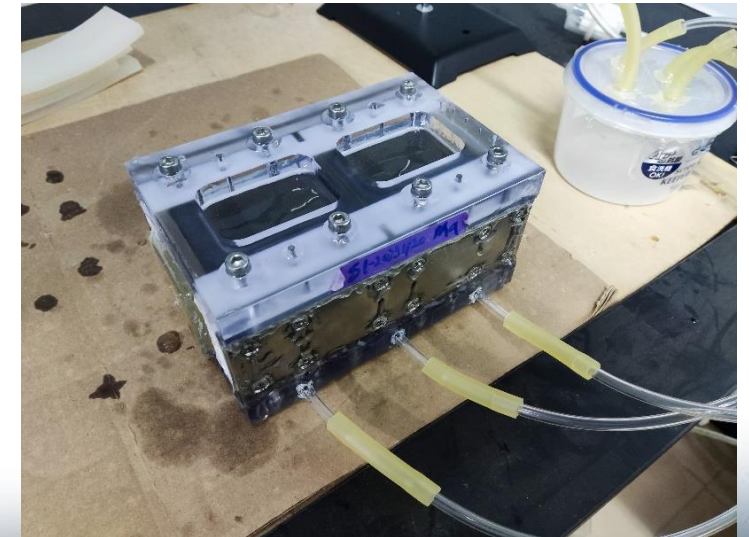
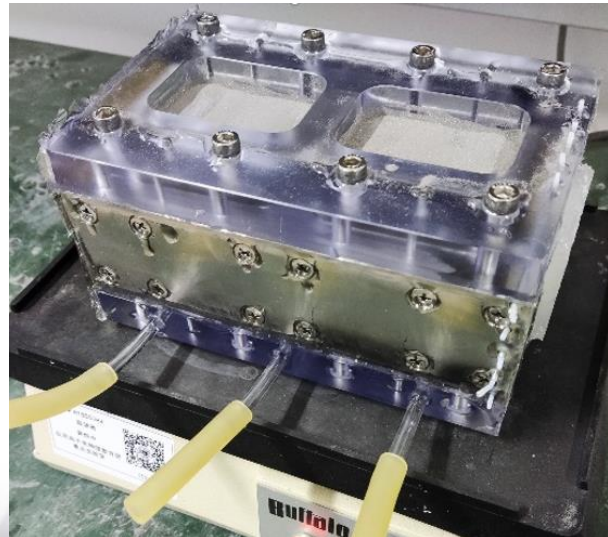

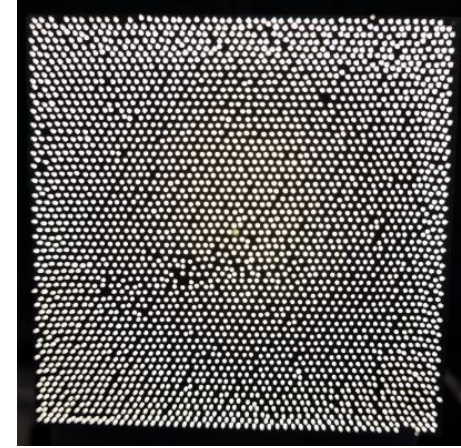
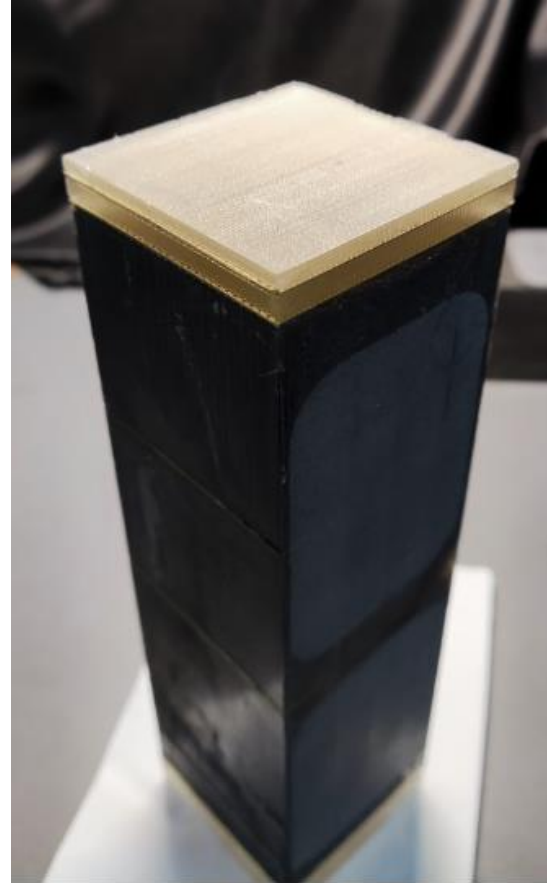



- We just finished the prototypes production flow.
- Got manpower from Tsinghua and Shandong Uni.
- Engineers and students were trained
- We got 12 blocks ready.

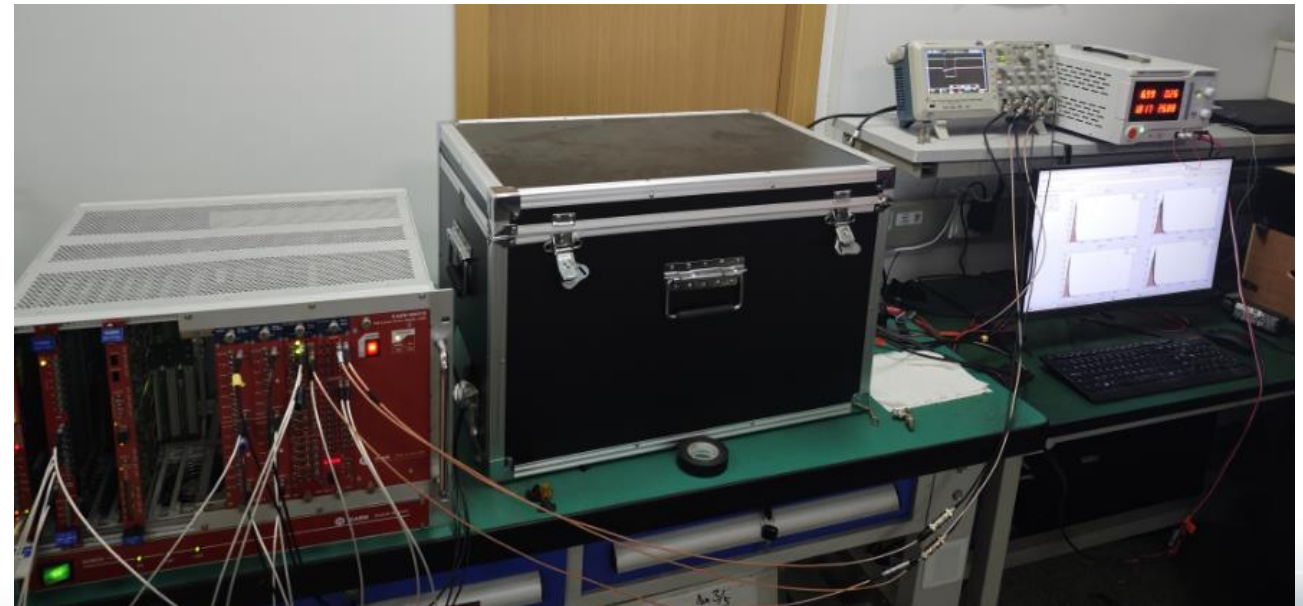
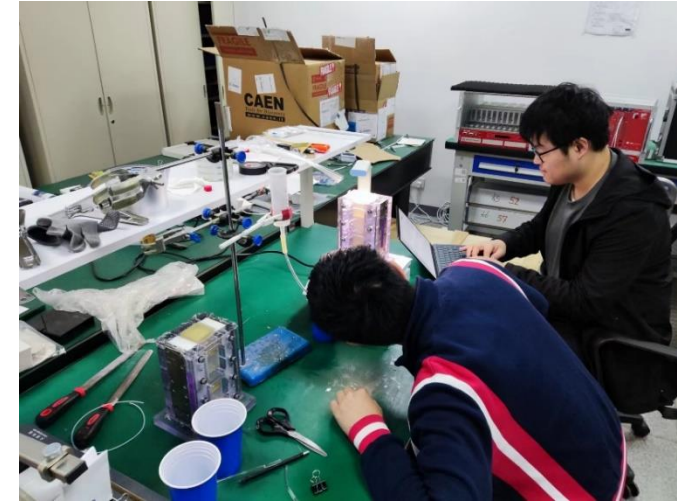

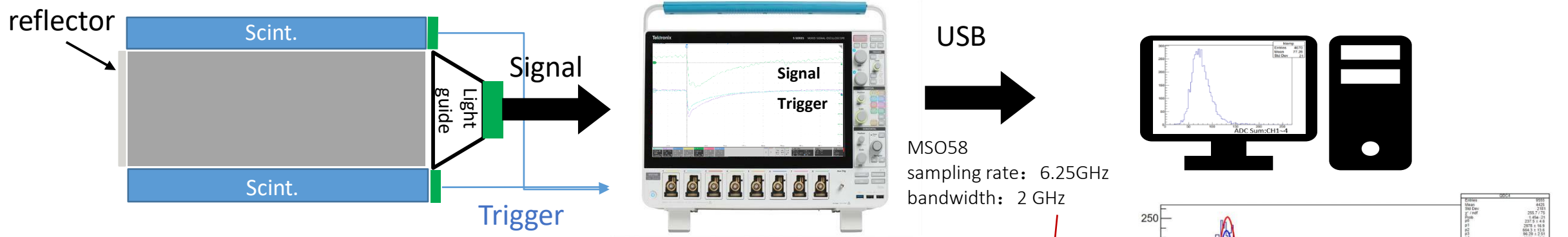

SiPM: S12572 (Hamamatsu)
4 × 4: 3mm × 3mm

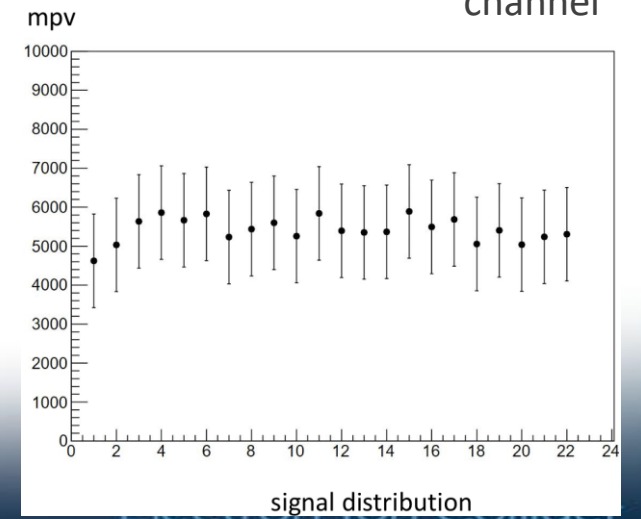
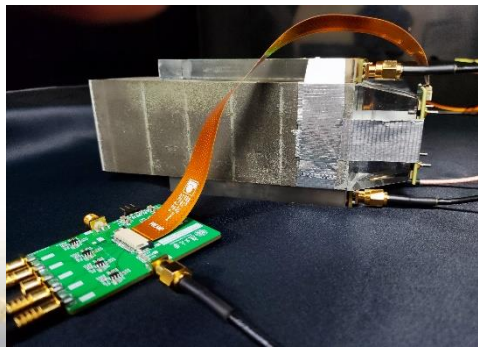
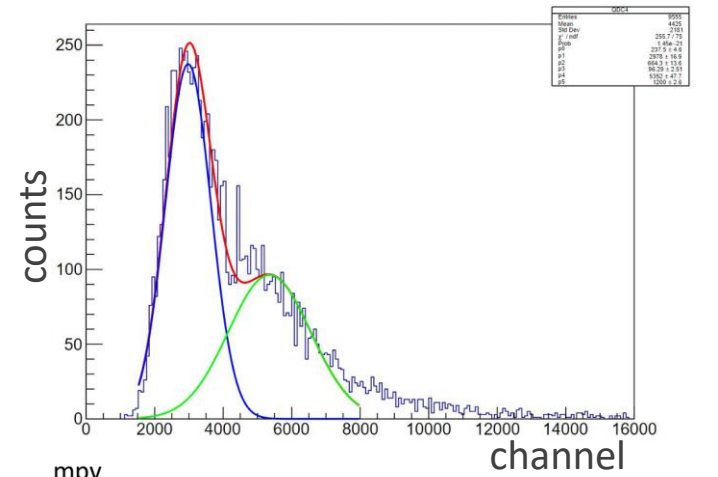
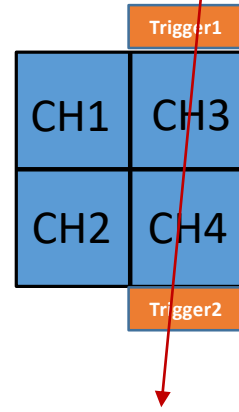
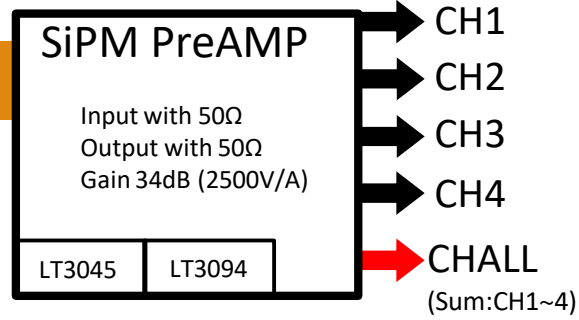
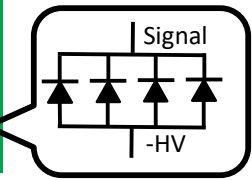
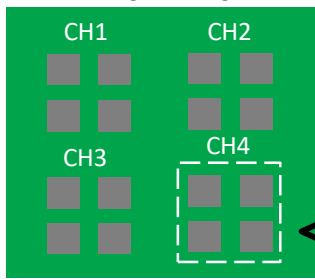

Shear tests performed at BNL

- The purpose of these tests is to measure safety factor for proposed mounting scheme of FECal at the ePIC configuration.
- With the tests performed, a very simple mounting scheme for FECal has been validated. Safety factor is larger than 75.
- Additional tests are being discussed (long term stability).

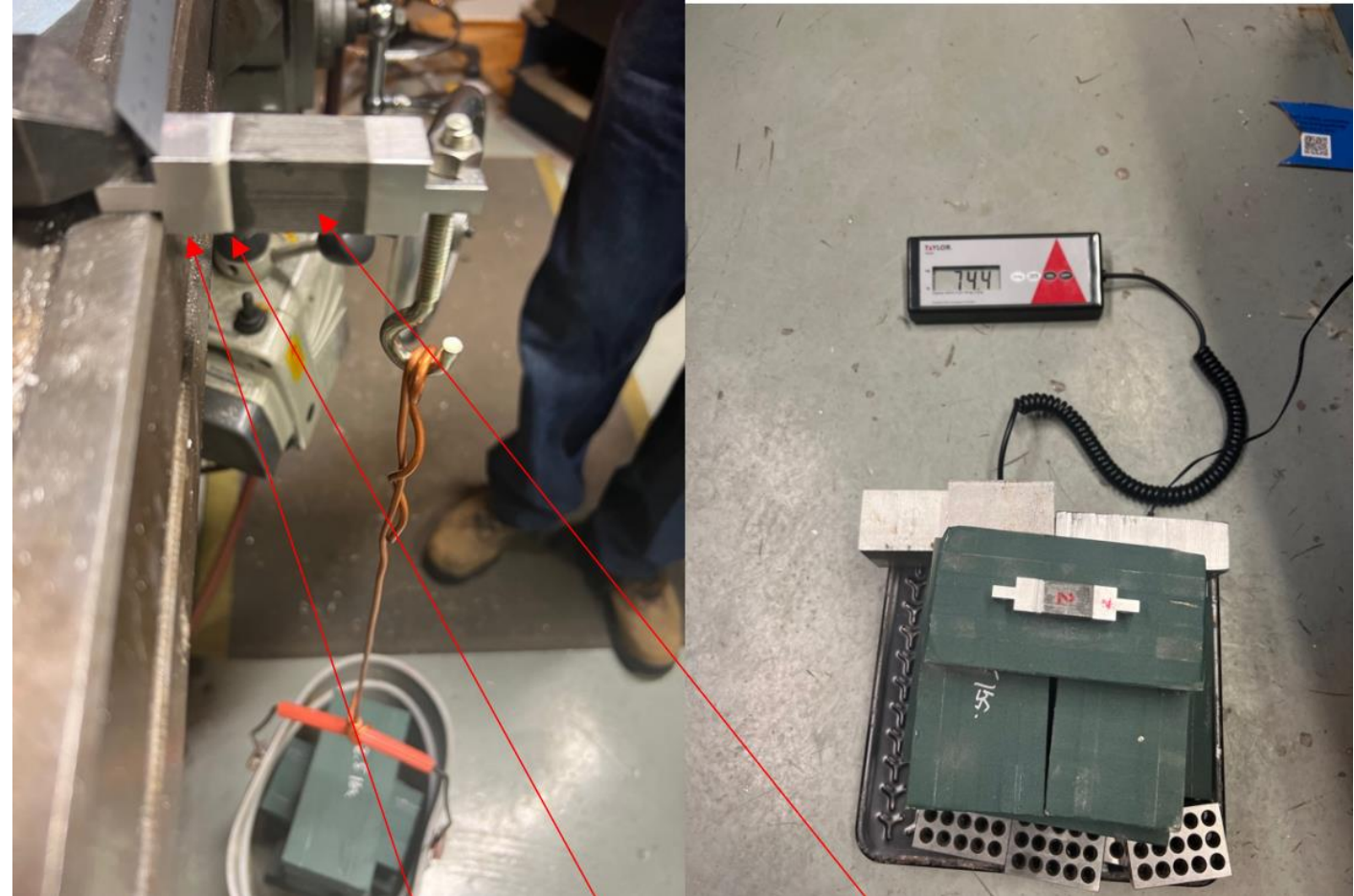

Al strong back, TiO_2 layer 2 mm thick, WScFi body.



A mechanical/optical/electrical integration of readout is part of this proposal. This activity is closely coordinated with eRD109 project. Latest integration concept developed by G. Visser (Indiana)

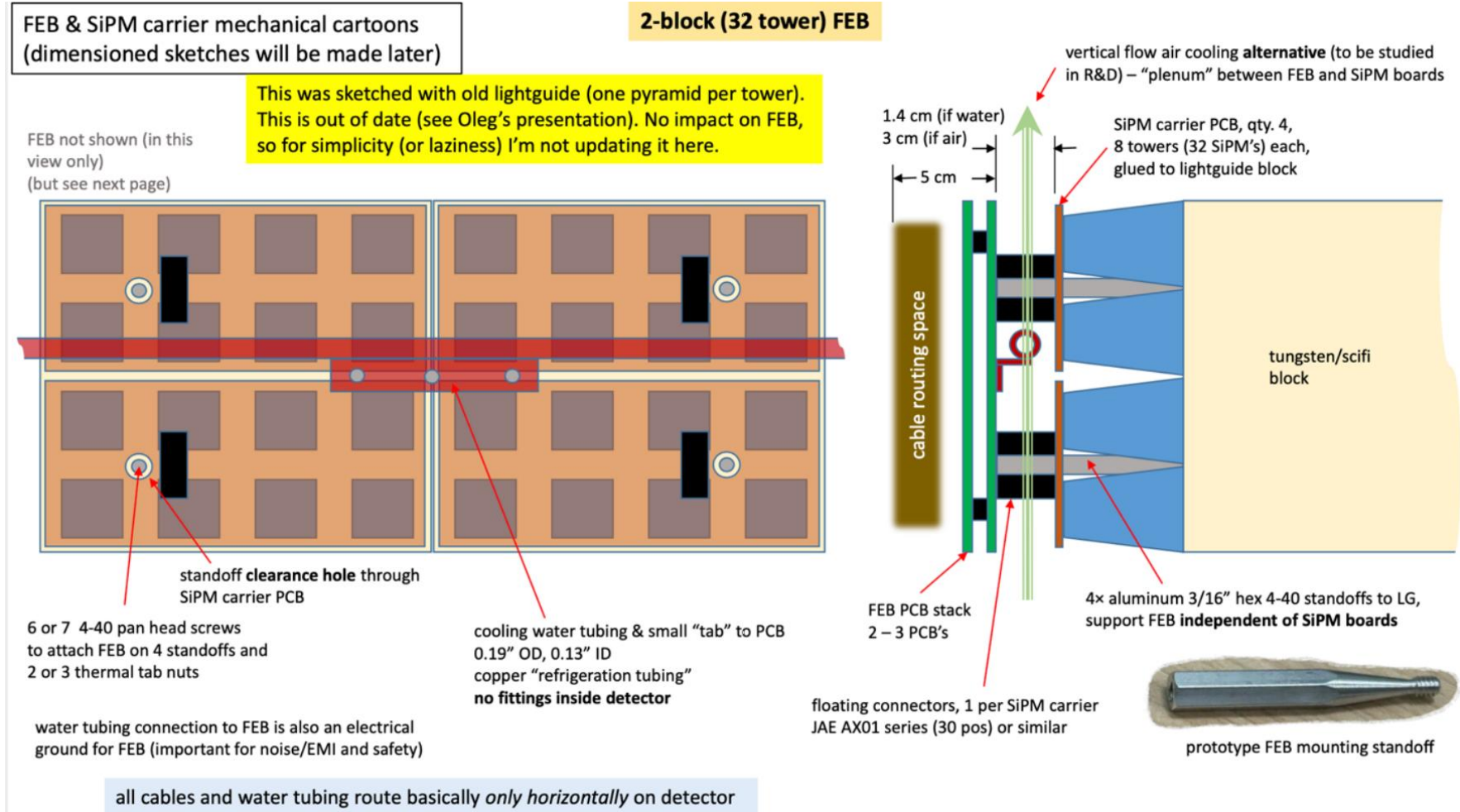

It includes redesigned light guides, FEB, SiPM boards, and cooling as well as mounting of readout electronics to FECal installation blocks.



pECal energy resolution for single photon input:

$$\frac{11.2\%}{\sqrt{E(\text{GeV})}} \oplus 2.0\%$$

pECal resolution

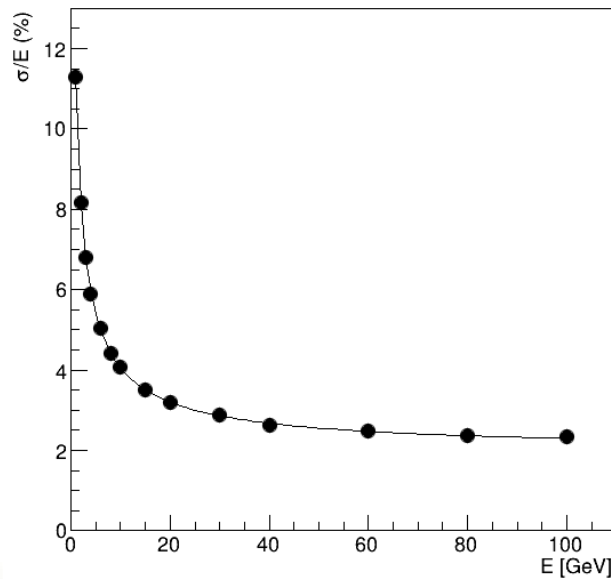

Pi0 merging rate by shower profile
Figure from EIC YR Fig. 11.46

Pi0 merging prob vs p

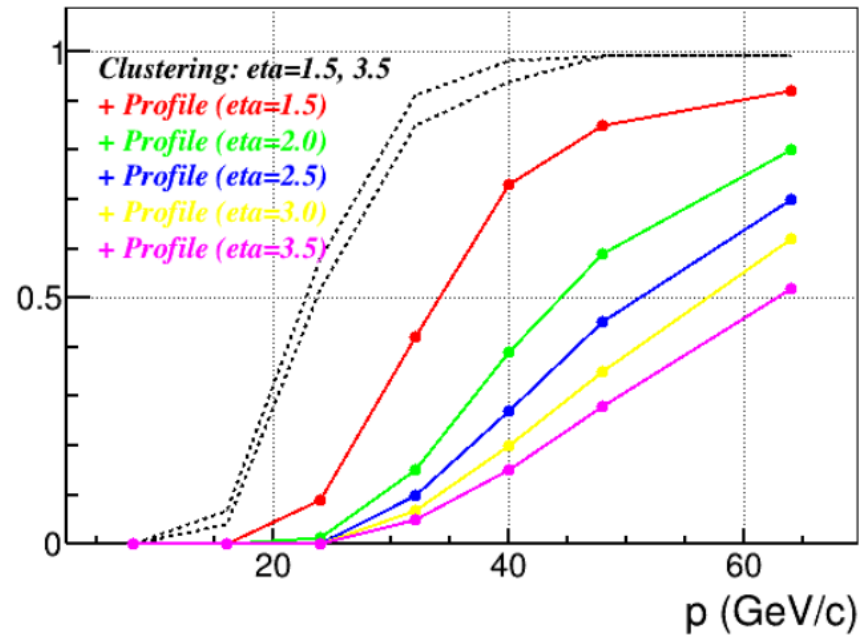

Pi0 merging rate from neural network at $\eta = 2$: Comparing with the green curve in the middle

Merging prob

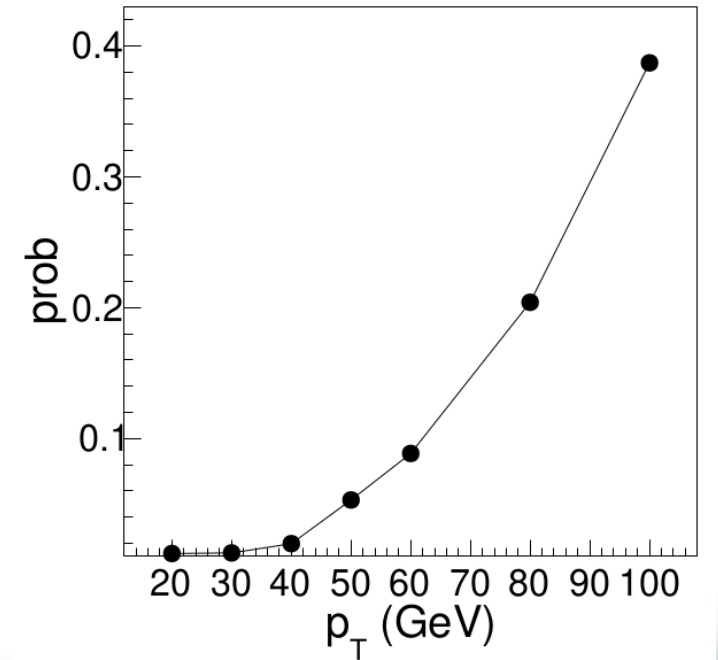



1. Contract for fibers is almost done. Luxium will supply fibers for forward ECal, first pre-production batch will be in hand in early fall.
2. We just ran a test run at FNAL, it was a short test run to check uniformity of response and get absolute light yield numbers. Data will be analyzed shortly. This will be the end of eRD106 (by the end of Summer)
3. Mechanical design for installation blocks and all mechanical tests were completed, including installation tests.
4. Design of light guides completed and manufacturing method almost finalized, we will be running some final tests with new tooling in a month or so. (these new light guides were tested in the lab as well as at FNAL).
5. Mechanical design of the whole ECal assembly is progressing, but somewhat slowly.
6. We were expecting visitors from India at UCLA to go through production steps in July, and made needed preparations here, but this visit is delayed now.
7. Integration and design of FEEs is in progress, we will be making final SiPM currying boards at UCLA in next month, then these will be tested with FOB at Indiana (these are final design SiPM boards with final SiPMs).



ePIC FECAL consortia

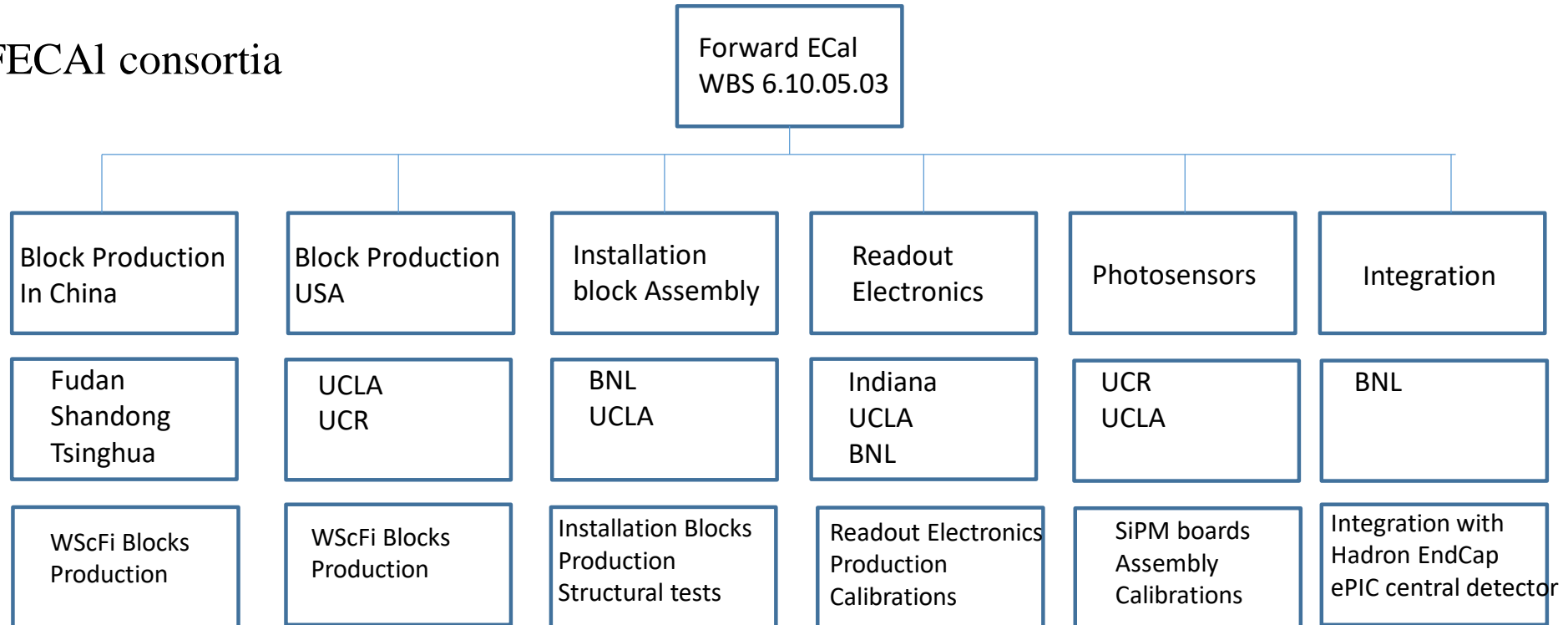

- Chinese FECal Consortium (Fudan University, Shandong University, Tsinghua University)
- University of California EIC Consortium (UCLA, UCR)
- Indian University
- BNL

Groups have extensive expertise and capabilities in executing large scale projects in high energy and nuclear physics experiments around the world. (RHIC, JLab, CERN, Super KEKB).



Production Plan

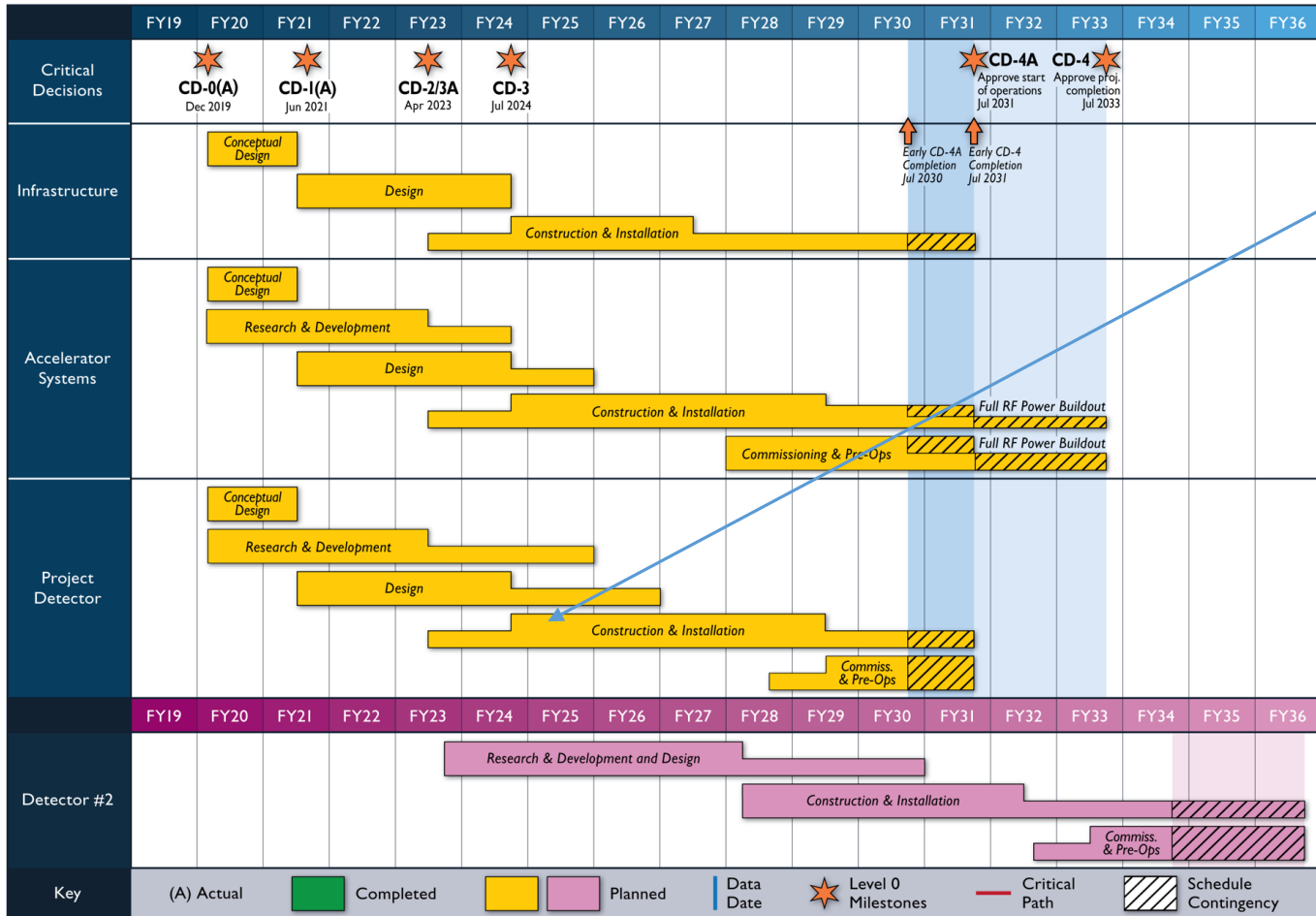

Post R&D

- Rump up production – 6 month
- Production – 3 years
- Installation 6 months

Enough schedule float.

Assumed, Production sites:

- China – 2/3 production blocks (backup plan is production of all blocks in the US)
- UC EIC (UCLA, UCR) – 1/3 production
- BNL – gluing 2/3 installation blocks and light guides.



- The structure and plans for FECal are well defined.
- The design of the forward ECal is based on mature technology and is well advanced.
- All participating institutions are committed and are making progress toward prototype production and preparation for full production.
- Workforce is experienced in executing large scale projects (including recently built forward calorimetry systems for STAR and participating in sPHENIX W/ScFi barrel ECal construction).
- Participating institutions have extensive capabilities to carry out large scale construction projects.
- Risks understood. Mitigation is part of the project plan.
- FECal had two successful CD3A reviews for long lead items past September, which were scintillation fibers and SiPMs.
- 12(Fudan)+4(UCLA) prototypes are ready.

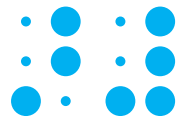

Thanks!

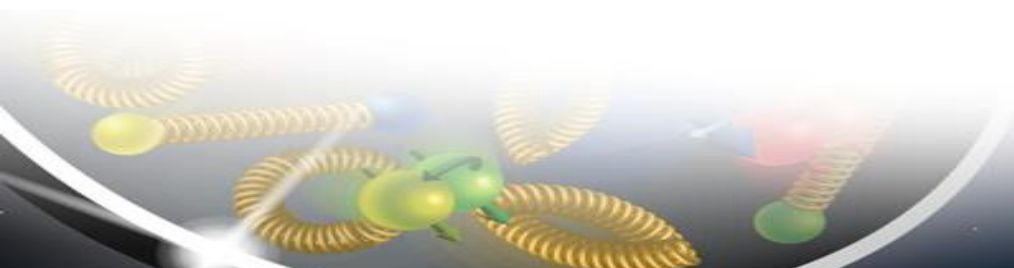

Fudan University has established the infrastructure for the construction of such W-powder/ScFi ECal blocks, including raw material procurement and testing, block production and processing, testing and QA, etc.

sPHENIX EMCAL blocks production flow at Fudan:



Fudan group has also experienced in producing and testing Pb/Sc Shashlyk EMCal modules with advanced standards and complete facilities.

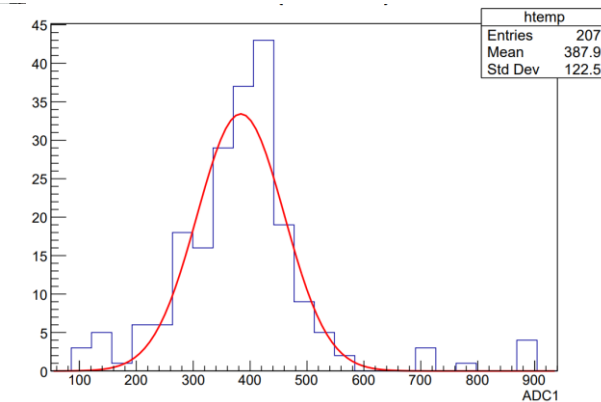
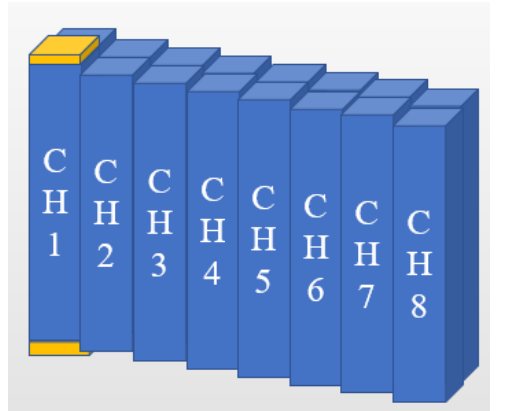
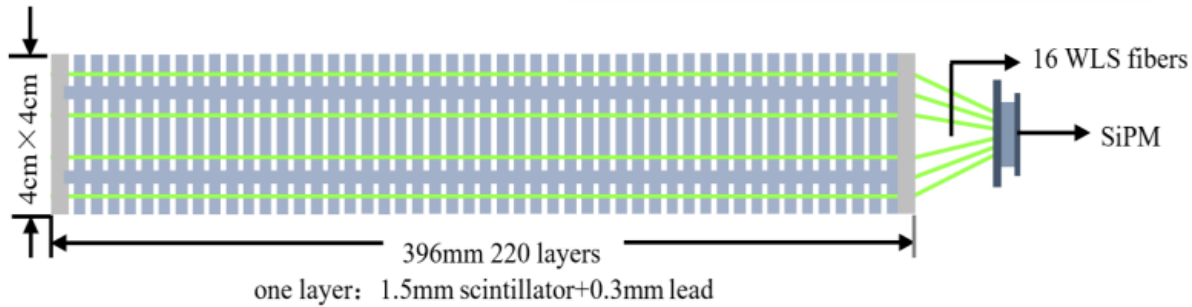

- The SDU group is currently working with RHIC-STAR experiment, and has been focusing on the nucleon spin structure and the heavy ion physics.
- We made the MWPC modules the inner TPC (iTTPC) upgrade at STAR, also produced the small-strip Thin Gap Chamber (sTGC) for the forward tracking upgrade at STAR. We are a key part of EMCAL R&D program for SOLID at Jlab.
- Pb/Sc Shashlyk EMCAL modules production.



Shashlyk prototyping

Front End Board for
SiPM-based Ecal

CNC center

- The Tsinghua group is currently working on multiple experimental projects at Jefferson Lab (Hall-A, B, C, SoLID) and RHIC-STAR experiment. Our major physics interests are on the hadronic structure of nucleons, e.g., spin, PDF, TMD, GPD, as well as the nuclear structure of nuclei, e.g. SRC & EMC effect, asymmetric energy, equation of states, critical points etc
- Tsinghua has extensive experience in developing the Shashlyk Ecal and the highresolution sealed MRPC. We constructed MRPCs for RICH-STAR, GSI-CBM and CSRCEE. We are leading or heavily involving in the R&D efforts for SoLID and US-EIC.



SoLID Shashlyk Ecal Beam Test at JLab

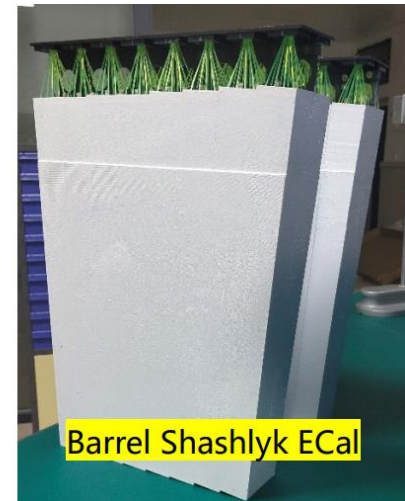

Barrel Shashlyk ECal